



Reyrolle
Protection
Devices

7SR242 Duobias

Transformer Protection Relay

Answers for energy.

SIEMENS

Contents

Technical Manual Chapters

1. Description of Operation
2. Settings, Configuration & Instruments
3. Performance Specification
4. Data Communications
5. Installation
6. Commissioning and Maintenance
7. Applications Guide

Software Revision History

2017/12	2662H85001 R8e-7e	Universal PSU fitted.
2017/08	2662H85001 R8c-7d	Phase currents added to 61850. 5A instruments corrected.
2015/11	2662H85001 R8b-7c	EN100+ compatibility. Additional '46IT' and '51' element time multiplier steps incorporated.
2013/01	2662H85001 R7c-7b	Revised file handling during shutdown
2012/08	2662H85001 R7b-7a (Requires hardware CC)	Addition of optional IEC 61850 communication protocol and Ethernet. Compatible with H/W CC
2010/02	2662H80001 R4c-3	Revisions to: VT ratio settings, 87BD 1st bias slope limit setting increments, CB fail function, LED CONFIG menu, DATA STORAGE menu. Added: Open circuit detection (46BC), CONTROL MODE menu, Close circuit supervision (74CCS), Measured earth fault undercurrent (37G), Pulsed output contacts.
2008/07	2662H80001R3d-2c.	Demand metering. Optional DNP3.0 data comms.
2008/05	2662H80001R3-2b	First Release.

Hardware Revision History

2015/11	DD	EN100+ Ethernet comms card replaces EN100.
2012/08	CC	Hardware revisions to allow integration of IEC 61850 functionality.
2008/05	BB	First Release

Contents

Technical Manual Chapters

1. Description of Operation
2. Settings, Configuration & Instruments
3. Performance Specification
4. Data Communications
5. Installation
6. Commissioning and Maintenance
7. Applications Guide

Software Revision History

2017/12	2662H85001 R8C-7d	Universal PSU
2017/08	2662H85001 R8C-7d	Phase currents added to 61850. 5A instruments corrected.
2015/11	2662H85001 R8b-7c	Additional '46IT' and '51' element time multiplier steps incorporated.
2013/01	2662H85001 R7c-7b	Revised file handling during shutdown
2012/08	2662H85001 R7b-7a (Requires hardware CC)	Addition of optional IEC 61850 communication protocol and Ethernet. Compatible with H/W CC
2010/02	2662H80001 R4c-3	Revisions to: VT ratio settings, 87BD 1st bias slope limit setting increments, CB fail function, LED CONFIG menu, DATA STORAGE menu. Added: Open circuit detection (46BC), CONTROL MODE menu, Close circuit supervision (74CCS), Measured earth fault undercurrent (37G), Pulsed output contacts.
2008/07	2662H80001R3d-2c.	Demand metering. Optional DNP3.0 data comms.
2008/05	2662H80001R3-2b	First Release.

Hardware Revision History

2015/11	DD	EN100+ Ethernet comms card replaces EN100.
2012/08	CC	Hardware revisions to allow integration of IEC 61850 functionality.
2008/05	BB	First Release

7SR242 Duobias

Multi-Function 2-Winding Transformer Protection Relay

Description of Operation

Document Release History

This document is issue **2019/08**. The list of revisions up to and including this issue is:

2019/08	Power supply options updated.
2017/12	Software revision 2662H85001 R8e-7e
2017/08	Software revision 2662H85001 R8c-7d
2015/11	7SR2424 added. RS485 comms terminal labelling revised (Figure 1-4). Text revisions to LED indications (2.5), inrush detector (5.3), waveform records (6.4.3) and fault data records (6.4.4).
2014/04	Section 6.4.3 - Waveform Records revised.
2013/01	Software revision 2662H85001 R7c-7b
2012/08	Addition of optional IEC 61850 communication protocol.
2010/06	Additional Comms modules option of (RS485 + IRIG-B) and (RS232 + IRIG-B) and typographical revisions
2010/02	Document reformat due to rebrand
2010/02	Software revision 2662H80001 R4c-3
2008/07	Software revision 2662H80001R3d-2c.
2008/05	First issue

The copyright and other intellectual property rights in this document, and in any model or article produced from it (and including any registered or unregistered design rights) are the property of Siemens Protection Devices Limited. No part of this document shall be reproduced or modified or stored in another form, in any data retrieval system, without the permission of Siemens Protection Devices Limited, nor shall any model or article be reproduced from this document unless Siemens Protection Devices Limited consent.

While the information and guidance given in this document is believed to be correct, no liability shall be accepted for any loss or damage caused by any error or omission, whether such error or omission is the result of negligence or any other cause. Any and all such liability is disclaimed.

Contents

Section 1: Introduction	7
Current Transformer Circuits	7
External Resistors.....	7
Fibre Optic Communication	7
Front Cover	7
Section 2: Hardware Description	15
2.1 General	15
2.2 Case.....	15
2.3 Front Cover	16
2.4 Power Supply Unit (PSU).....	16
2.5 Operator Interface/ Fascia	16
2.6 Current Inputs	19
2.7 Voltage Input.....	19
2.8 Binary inputs	19
2.9 Binary outputs (Output Relays).....	20
2.10 Virtual Input/Outputs	21
2.11 Self Monitoring	22
2.11.1 Protection Healthy/Defective.....	22
Section 3: Protection Functions	23
3.1 Current Protection: Differential Protection	23
3.1.1 ICT.....	23
3.1.2 Overall Biased Differential (87BD)	24
3.1.3 87HS	26
3.2 Current Protection: Phase Overcurrent (51, 50).....	28
3.2.1 Instantaneous Overcurrent Protection (50).....	28
3.2.2 Time Delayed Overcurrent Protection (51)	29
3.3 Current Protection: Derived Earth Fault (50N, 51N).....	30
3.3.1 Instantaneous Derived Earth Fault Protection (50N)	30
3.3.2 Time Delayed Derived Earth Fault Protection (51N)	31
3.4 Current Protection: Measured Earth Fault (50G, 51G).....	32
3.4.1 Instantaneous Measured Earth Fault Protection (50G)	32
3.4.2 Time Delayed Measured Earth Fault Protection (51G).....	33
3.5 Current Protection: High Impedance Restricted Earth Fault (64H)	34
3.6 Open Circuit (46BC).....	35
3.7 Current Protection: Negative Phase Sequence Overcurrent (46NPS).....	36
3.8 Current Protection: Under-Current (37, 37G)	37
3.9 Current Protection: Thermal Overload (49)	38
3.10 Voltage Protection: Over Fluxing (24).....	40
3.11 Voltage Protection: Under/Over Voltage (27/59)	42
3.12 Voltage Protection: Neutral Overvoltage (59N)	43
3.13 Voltage Protection: Under/Over Frequency (81)	45
Section 4: Control & Logic Functions	46
4.1 Quick Logic	46
Section 5: Supervision Functions	48
5.1 Circuit Breaker Failure (50BF)	48
5.2 Trip/Close Circuit Supervision (74TCS/74CCS)	50
5.3 Inrush Detector (81HBL2).....	51

5.4 Over Fluxing Detector (81HBL5).....	52
Section 6: Other Features.....	54
6.1 Data Communications.....	54
6.2 IEC 61850 Communications	54
6.3 Maintenance.....	55
6.3.1 Output Matrix Test.....	55
6.3.2 CB Counters.....	55
6.3.3 I ² t CB Wear	55
6.4 Data Storage.....	56
6.4.1 General.....	56
6.4.2 Event Records.....	56
6.4.3 Waveform Records	56
6.4.4 Fault Data Records	57
6.4.5 Demand.....	57
6.4.6 Demand/Data Log	57
6.5 Metering	58
6.6 Operating Mode	58
6.7 Control Mode.....	58
6.8 Real Time Clock.....	59
6.8.1 Time Synchronisation – Data Comms	59
6.8.2 Time Synchronisation – Binary Input	59
6.8.3 Time Synchronisation – IRIG-B (Optional).....	59
6.9 Settings Groups	59
6.10 Password Feature	60

List of Figures

Figure 1-1	Function Diagram: 7SR242n-2aAnn-0AA0 Relay	10
Figure 1-2	Function Diagram: 7SR242n-2aAnn-0BA0 Relay	11
Figure 1-3	Function Diagram: 7SR242n-2aAnn-0CA0 Relay	12
Figure 1-4	Connection Diagram: 7SR242 Relay	13
Figure 2-1	7SR24 with 3 + 16 LEDs in E8 Case	16
Figure 2-2	Binary Input Logic	19
Figure 2-3	Binary Output Logic	21
Figure 2.11-1	Start-up Counter Meter	22
Figure 3-1	Biased Differential Characteristic.....	24
Figure 3-2	Functional Diagram for Biased Current Differential Protection.....	25
Figure 3-3	Differential Highset Characteristic	26
Figure 3-4	Logic Diagram: High Set Current Differential Protection	27
Figure 3-5	Logic Diagram: Instantaneous Over-current Element	28
Figure 3-6	Logic Diagram: Time Delayed Overcurrent Element	29
Figure 3-7	Logic Diagram: Instantaneous Derived Earth Fault Element.....	30
Figure 3-8	Logic Diagram: Derived Time Delayed Earth Fault Protection	31
Figure 3-9	Logic Diagram: Measured Instantaneous Earth-fault Element.....	32
Figure 3-10	Logic Diagram: Time Delayed Measured Earth Fault Element (51G)	33
Figure 3-11	Logic Diagram: High Impedance REF (64H)	34
Figure 3-12	Logic Diagram: Open Circuit Function (46BC)	35
Figure 3-13	Logic Diagram: Negative Phase Sequence Overcurrent (46NPS)	36
Figure 3-14	Logic Diagram: Undercurrent Detector (37, 37G).....	37
Figure 3-15	Logic Diagram: Thermal Overload Protection (49)	39
Figure 3-16	Inverse Over-fluxing Characteristic (24IT)	40
Figure 3-17	Logic Diagram: Overfluxing Elements (24)	41
Figure 3-18	Logic Diagram: Under/Over Voltage Elements (27/59)	42
Figure 3-19	Logic Diagram: Neutral Overvoltage Element	44
Figure 3-20	Logic Diagram: Under/Over Frequency Detector (81)	45
Figure 4-1	Sequence Diagram showing PU/DO Timers in Quick Logic (Counter Reset Mode Off)	47
Figure 5-1	Logic Diagram: Circuit Breaker Fail Protection (50BF).....	49
Figure 5-2	Logic Diagram: Trip Circuit Supervision Feature (74TCS)	50
Figure 5-3	Logic Diagram: Close Circuit Supervision Feature (74CCS).....	50
Figure 5-4	Logic Diagram: Inrush Detector Feature (81HBL2)	51
Figure 5-5	Logic Diagram: Overfluxing Detector Feature (81HBL5).....	52









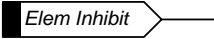
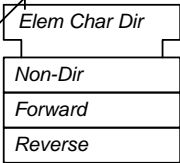
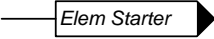
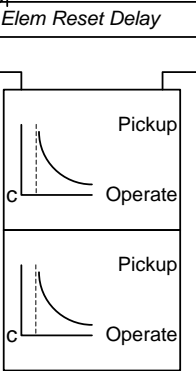
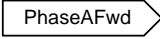

List of Tables

Table 1-1:	7SR242 Ordering Options.....	8
Table 2-1	Summary of 7SR24 Relay Configurations	15
Table 6-1	Operating Mode	58

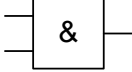
Symbols and Nomenclature

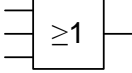
The following notational and formatting conventions are used within the remainder of this document:

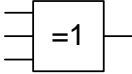
- Setting Menu Location MAIN MENU>SUB-MENU
- Setting: ***Elem name -Setting***
- Setting value: **value**
- Alternatives: **[1st] [2nd] [3rd]**

Binary input signal visible to user		List of settings associated with a specific function Appropriate list is TRUE when setting selected.	
Binary Output visible to user		Common setting for multiple functions	
Digital signal not visible to user, to/from another element		Common control input (c) for multiple functions. All functions are enabled when control input is TRUE.	
Digital signal not visible to user, internal to this element		Function.	
Analogue signal with signal description		Individual functions are enabled when associated control input (c) is TRUE.	
And Gate (2 inputs shown)		EVENT: IEC, Modbus, DNP etc. Where applicable	
Or Gate (3 inputs shown)		Relay instrument	
Exclusive Or (XOR) Gate (3 inputs shown)			
Latch (Set/Reset)			
Positive Edge Trigger			

Section 1: Introduction

This manual is applicable to the following relays:

- **7SR242 Multi-Function 2-Winding Transformer Protection Relay**

The 7SR242 relay integrates the protection and control elements required to provide a complete transformer protection.

The 'Ordering Options' Tables summarise the features available in each model.

General Safety Precautions



Current Transformer Circuits

The secondary circuit of a live CT must not be open circuited. Non-observance of this precaution can result in injury to personnel or damage to equipment.



External Resistors

Where external resistors are fitted to relays, these may present a danger of electric shock or burns, if touched.



Fibre Optic Communication

Where fibre optic communication devices are fitted, these should not be viewed directly. Optical power meters should be used to determine the operation or signal level of the device.



Front Cover

The front cover provides additional securing of the relay element within the case. The relay cover should be in place during normal operating conditions.

Table 1-1: 7SR242 Ordering Options

DUOBIAS-M

Multifunctional 2 winding transformer differential protection

Protection Product
Transformer

Relay Type
Differential (2 winding)

Case I/O and Fascia
E8 case, 6 CT, 2 EF/REF CT, 1 VT, 9 Binary Inputs / 6 Binary Outputs, 16 LEDs
E10 case, 6 CT, 2 EF/REF CT, 1 VT, 19 Binary Inputs / 14 Binary Outputs, 24 LEDs
E12 case, 6 CT, 2 EF/REF CT, 1 VT, 39 Binary Inputs / 14 Binary Outputs, 32 LEDs

Measuring Input
1/5 A, 40 - 160V, 50/60Hz

Auxiliary voltage
PSU Rated: 24-250V DC / 100-230V AC. Binary Input threshold 19V DC (Rated: 24-250V DC)
PSU Rated: 24-250V DC / 100-230V AC. Binary Input threshold 88V DC (Rated: 110-250V DC)

Communication Interface
Standard version – included in all models, USB front port, RS485 rear port
Standard version – plus additional rear F/O ST connectors (x2) and IRIG-B
Standard version – plus additional rear RS485 (x1) and IRIG-B
Standard version – plus additional rear RS232 (x1) and IRIG-B
Standard version – plus additional rear Electrical Ethernet RJ45 (x2)
Standard version – plus additional rear Optical Ethernet Duplex (x2)

Protocol
IEC 60870-5-103 and Modbus RTU (user selectable setting)
IEC 60870-5-103, Modbus RTU and DNP 3.0 (user selectable)
IEC 60870-5-103, Modbus RTU and DNP 3.0 (user selectable) and IEC61850

Protection Function Packages
Option A: Standard version – Included in all models
- 81HBL2 Inrush Detector
- 81HBL5 Overfluxing detector
- 87BD Biased current differential
- 87HS Current differential highest
Programmable logic
For each winding/circuit breaker
- 50BF Circuit breaker fail
- 64H High impedance REF
- 74TCS/CCS Trip/close circuit supervision

Option B: Standard version – plus
- 37/37G Undercurrent
- 46BC Open circuit
- 46NPS Negative phase sequence overcurrent
- 49 Thermal overload
- 50 Instantaneous phase fault overcurrent
- 50G/50N Instantaneous earth fault
- 51 Time delayed phase fault overcurrent
- 51G/51N Time delayed earth fault

(continued on following page)

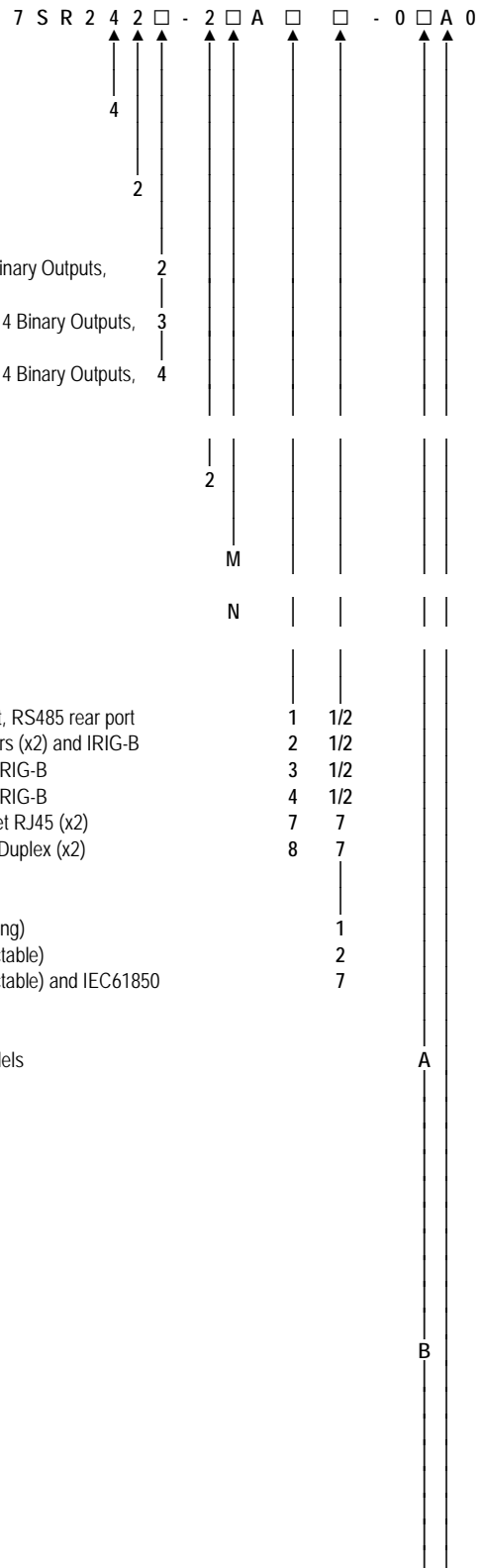

DUOBIAS-M

7 S R 2 4 2 □ - 2 □ A □ □ - 0 □ A 0

(continued from previous page)

<u>Option C:</u>	Standard version - plus
- 24	Overfluxing
- 27/59	Under/overvoltage
- 59N	Neutral voltage displacement
- 81	Under/overfrequency
- 37/37G	Undercurrent
- 46BC	Open circuit
- 46NPS	Negative phase sequence overcurrent
- 49	Thermal overload
- 50	Instantaneous phase fault overcurrent
- 50G/50N	Instantaneous earth fault
- 51	Time delayed phase fault overcurrent
- 51G/51N	Time delayed earth fault

Additional Functionality
No Additional Functionality



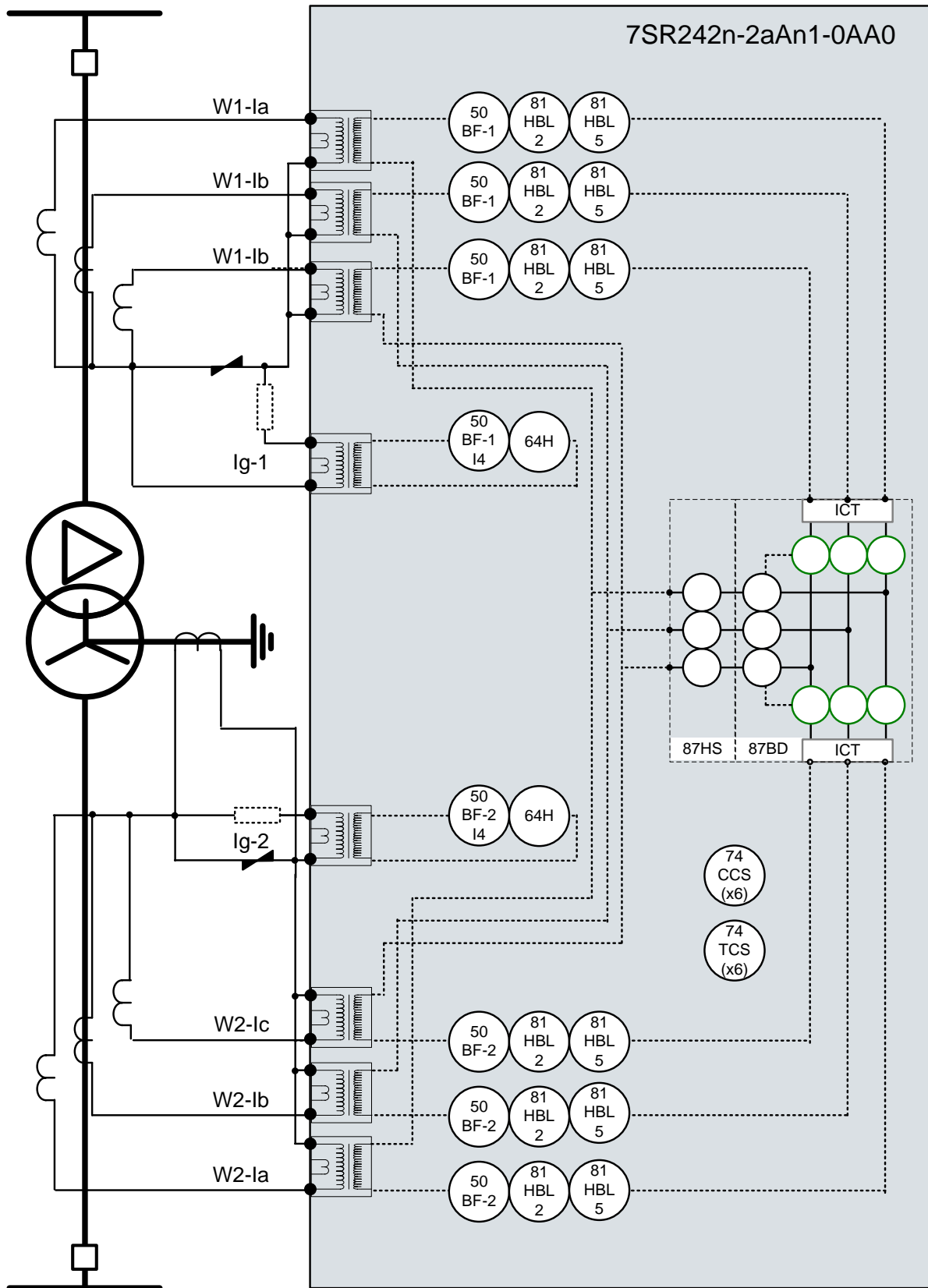

Figure 1-1 Function Diagram: 7SR242n-2aAnn-0AA0 Relay

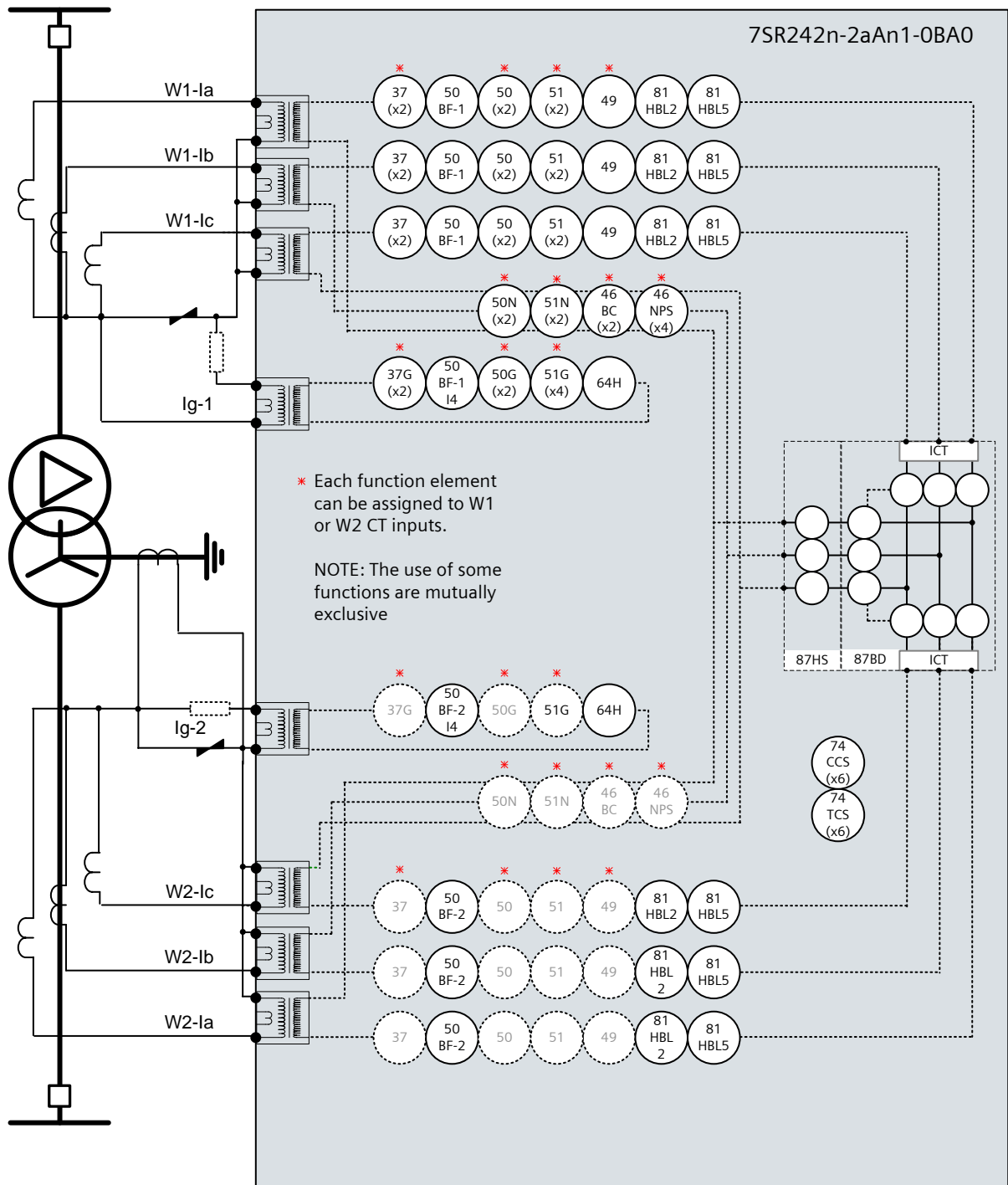

Figure 1-2 Function Diagram: 7SR242n-2aAnn-0BA0 Relay

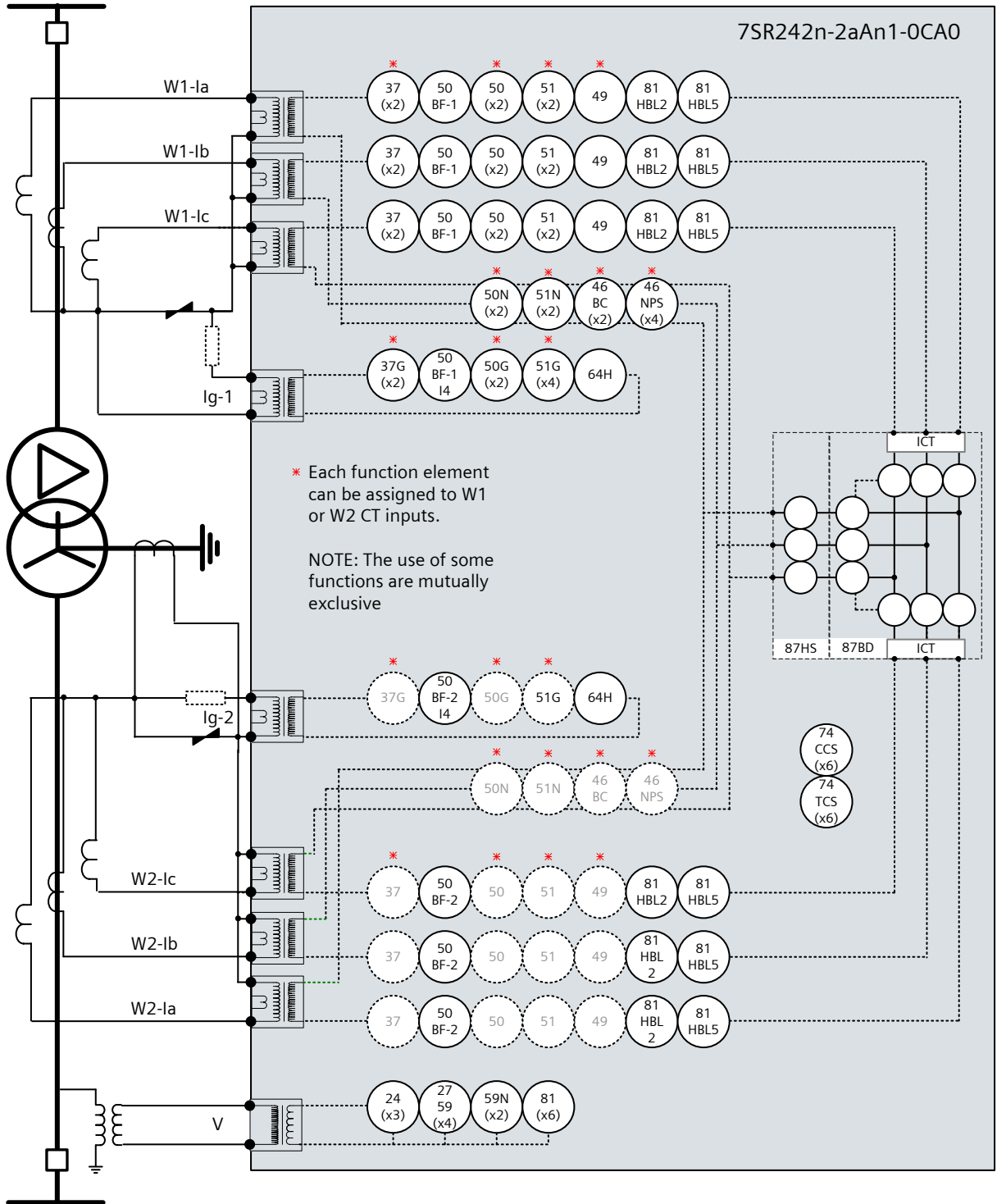
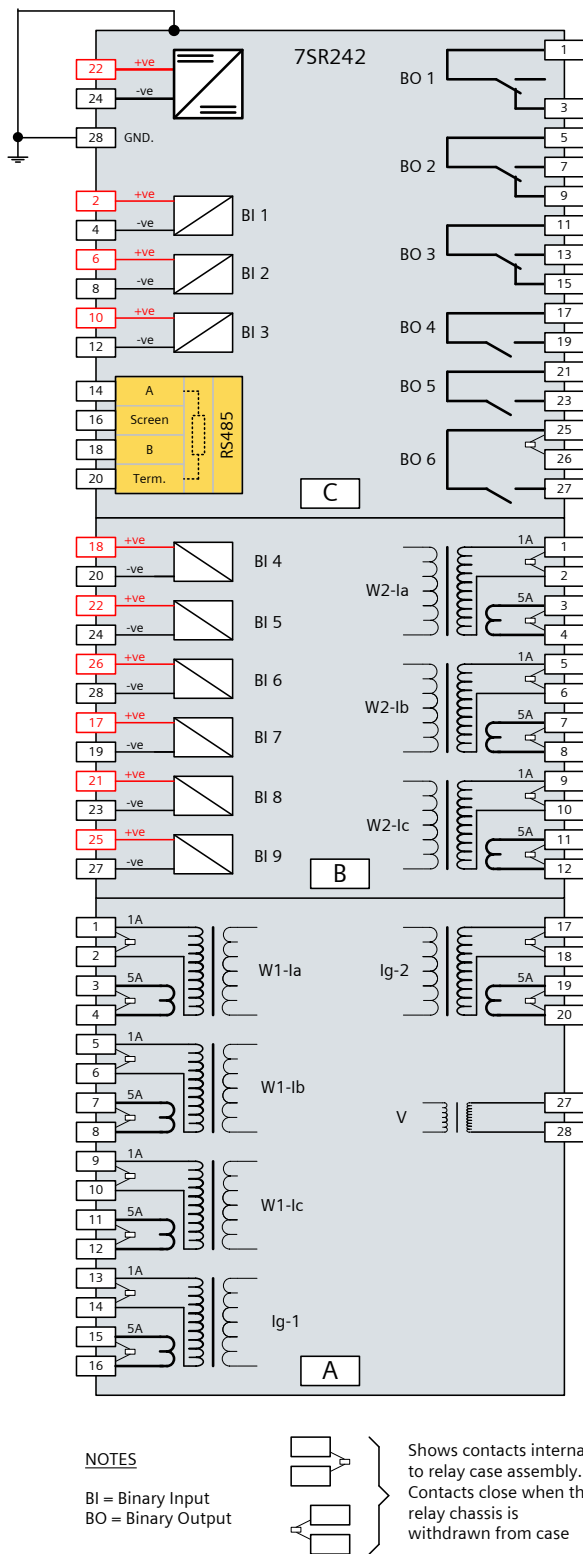
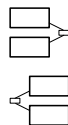

Figure 1-3 Function Diagram: 7SR242n-2aAnn-0CA0 Relay



NOTES

BI = Binary Input
BO = Binary Output



Shows contacts internal to relay case assembly. Contacts close when the relay chassis is withdrawn from case

Rear View: Arrangement of terminals and modules

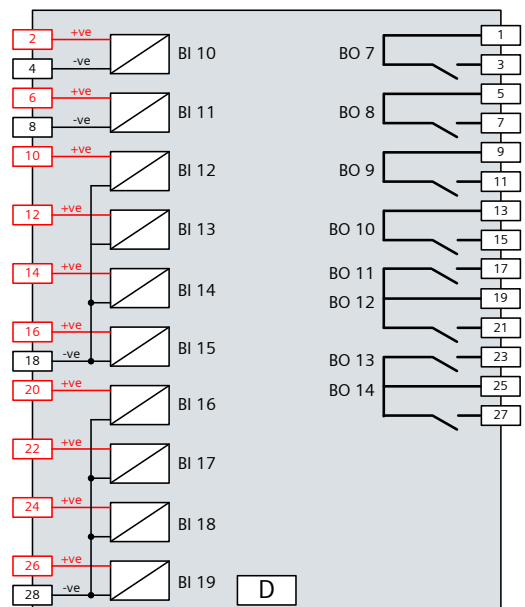
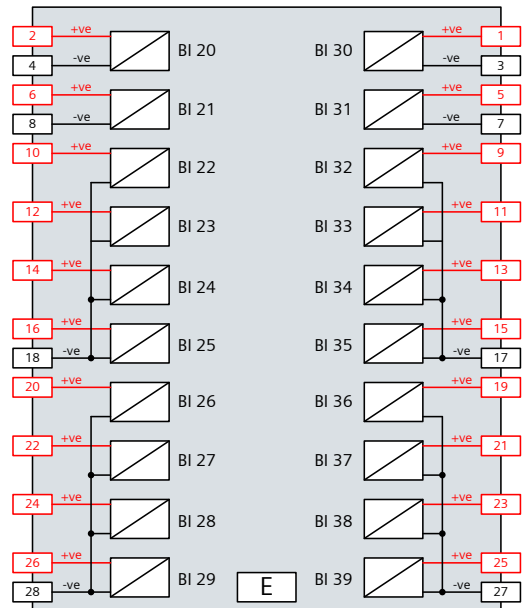
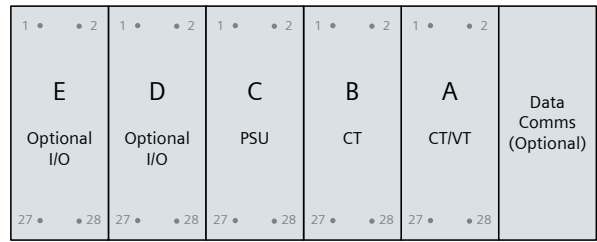

Figure 1-4 Connection Diagram: 7SR242 Relay

Section 2: Hardware Description

2.1 General

The structure of the relay is based upon the Multi-function hardware platform. The relays are supplied in either size E8, E10 or E12 cases (where 1 x E = width of approx. 26mm). The hardware design provides commonality between products and components across the 7SR2 range of relays.

Table 2-1 Summary of 7SR24 Relay Configurations

Relay	Current Inputs	Voltage Inputs	Binary Inputs	Output Relays	LEDs	Case
7SR2422	8	1	9	6	16	E8
7SR2423	8	1	19	14	24	E10
7SR2424	8	1	39	14	32	E12

Relays are assembled from the following modules:

- 1) Front Fascia with three fixed function LEDs and ordering options of configurable LEDs.
- 2) Processor module
- 3) Analogue Input module 'A': 3 x Current + 6 x Binary Inputs
- 4) Analogue Input module 'B': 5 x Current + 1 x Voltage.
- 5) Power Supply and basic Binary Input (BI) and Binary Output (BO).
- 6) Optional Binary Input/Output Module
- 7) Optional Binary Input Module
- 8) Optional data comms module

2.2 Case

The relays are housed in cases designed to fit directly into standard panel racks.

The complete relay assembly is withdrawable from the front of the case. Contacts in the case ensure that the CT circuits remain short-circuited when the relay is removed. Note that when the optional Ethernet comms module is fitted to the relay the comms cables and the EN100 module rear securing screw must be removed before the relay assembly is withdrawn.

The rear terminal blocks comprise M4 screw terminals for wire connections. Each terminal can accept two 90 degree ring tongue crimps.

Located at the top rear of the case is a screw clamp earthing point, this must be connected to the main panel earth.

See Chapter 5 (Installation Guide) for full details of panel cut-out and internal clearance requirements.

2.3 Front Cover

With the transparent front cover in place the user only has access to the ▼ and **TEST/RESET**► buttons, allowing all areas of the menu system to be viewed, but preventing setting changes and control actions. The only 'action' that is permitted is to reset the Fault Data display, latched binary outputs and LEDs by using the **TEST/RESET** ► button.

The front cover is used to secure the relay assembly in the case.

2.4 Power Supply Unit (PSU)

The relay PSU can be directly connected to any substation dc system rated from 30V dc to 220V dc.

In the event of the station battery voltage level falling below the relay minimum operate level the PSU will automatically switch itself off and latch out – this prevents any PSU overload conditions occurring. The PSU is reset by switching the auxiliary supply off then on.

Typically the PSU is connected to the auxiliary supply via an external HRC fuse rated at 6A (BS88/IEC60259). Isolation links may also be installed in accordance with user requirements.

2.5 Operator Interface/ Fascia

The operator interface is designed to provide a user-friendly method of controlling, entering settings and retrieving data from the relay.



Figure 2-1 7SR24 with 3 + 16 LEDs in E8 Case

NOTE: Pushbuttons on cover not shown

The fascia is an integral part of the relay. Handles are located at each side of the element to allow it to be withdrawn from the relay case.

Relay Information

Above the LCD three labels are provided, these provide the following information:

- 1) Product name and order code.
- 2) Nominal current rating, rated frequency, voltage rating, auxiliary dc supply rating, binary input supply rating, configuration and serial number.
- 3) Blank label for user defined information.

A 'template' is available within the 'Reydisp' program to allow users to create and print customised LED label inserts.

The warning and information labels on the relay fascia provide the following information:



Dielectric Test Voltage 2kV



Impulse Test Above 5kV



Caution: Refer to Equipment Documentation



Caution: Risk of Electric Shock

Liquid Crystal Display (LCD)

A 4 line by 20-character liquid crystal display indicates settings, instrumentation, fault data and control commands.

To conserve power the display backlighting is extinguished when no buttons are pressed for a user defined period. A setting within the "SYSTEM CONFIG" menu allows the timeout to be adjusted from 1 to 60 minutes and "Off" (backlight permanently on). After an hour the display is completely de-activated. Pressing any key will re-activate the display.

The LCD contrast can be adjusted using a flat blade screwdriver to turn the screw located below the contrast symbol . Turning the screw clockwise increases the contrast, anti-clockwise reduces the contrast.

'PROTECTION HEALTHY' LED

This green LED is steadily illuminated to indicate that DC voltage has been applied to the relay power supply and that the relay is operating correctly. If the internal relay watchdog detects an internal fault then this LED will continuously flash.

'PICKUP' LED

This yellow LED is illuminated to indicate that a user selectable function(s) has picked up. The LED will self reset after the initiating condition has been removed.

Functions are assigned to the PICKUP LED in the OUTPUT CONFIG>PICKUP CONFIG menu.

'TRIP' LED

This red LED is steadily illuminated to indicate that a user selectable function has operated to trip the circuit breaker. Functions are assigned to the 'Trip' LED using the OUTPUT CONFIG>Trip Contacts setting.

Operation of the LED is latched and can be reset by either pressing the TEST/RESET ► button, energising a suitably programmed binary input, or, by sending an appropriate command over the data communications channel(s).

Indication LEDs

Relays have either 16, 24 or 32 user programmable LED indicators. Each LED can be programmed to be illuminated as either green, yellow or red. Where an LED is programmed to be lit both red and green it will illuminate yellow. . Each LED can be assigned two different colours dependent upon whether a Start/Pickup or Operate condition initiates operation. The LED illumination colour is assigned in the OUTPUT CONFIG>LED CONFIG menu for both Pickup and Operate initiation.

Functions are assigned to the LEDs in the OUTPUT CONFIG>OUTPUT MATRIX menu.

Each LED can be labelled by withdrawing the relay and inserting a label strip into the pocket behind the front fascia. A 'template' is available to allow users to create and print customised legends.

Each LED can be user programmed as hand or self–resetting. Hand reset LEDs can be reset by either pressing the TEST/RESET ► button, energising a suitably programmed binary input, or, by sending an appropriate command over the data communications channel(s).

The status of hand reset LEDs is maintained by a back up storage capacitor in the event of an interruption to the d.c. supply voltage. The length of time for which the LED status will be maintained will depend on such things as temperature, length of time in service, etc. However the status will be maintained for a minimum of 1.8 days.

LED status stored in fault data records are backed up in non-volatile memory and are permanently stored even in the event of loss of auxiliary d.c. supply voltage, see section 6.4.4

Standard Keys

The relay is supplied as standard with five pushbuttons. The buttons are used to navigate the menu structure and control relay functions. They are labelled:

▲	Increases a setting or moves up menu.
▼	Decreases a setting or moves down menu.
TEST/RESET ►	Moves right, can be used to reset selected functionality and for LED test (at relay identifier screen).
ENTER	Used to initiate and accept settings changes.
CANCEL.	Used to cancel settings changes and/or move up the menu structure by one level per press.

NOTE: All settings and configuration of LEDs, BI, BO and function keys can be accessed and set by the user using these keys. Alternatively configuration/settings files can be loaded into the relay using 'ReyDisp'.

2.6 Current Inputs

In total eight current inputs are provided on the Analogue Input modules. Terminals are available for both 1A and 5A inputs. CT ratios are input by the user in the CT/VT CONFIG menu.

Current is sampled at 1600Hz for 50Hz systems and 1920Hz for 60Hz systems (32 samples per cycle).

The waveform recorder samples and displays current input waveforms at 32 samples per cycle.

2.7 Voltage Input

An optional voltage input is provided on the Analogue Input module 'A'.

VT ratios are input by the user in the CT/VT CONFIG menu.

Voltage is sampled at 1600Hz for 50Hz systems and 1920Hz for 60Hz systems (32 samples per cycle).

The waveform recorder displays the voltage input waveform at 32 samples per cycle.

2.8 Binary inputs

The binary inputs are opto-couplers operated from a suitably rated dc supply.

Relays are fitted with 9 or 19 binary inputs (BI). The user can assign any binary input to any of the available functions (INPUT CONFIG > INPUT MATRIX).

The Power Supply module includes the relay basic I/O. The module includes 3 x BI.

Pick-up (PU) and drop-off (DO) time delays are associated with each binary input. Where no pick-up time delay has been applied the input may pick up due to induced ac voltage on the wiring connections (e.g. cross site wiring). The default pick-up time of 20ms provides ac immunity. Each input can be programmed independently.

Each input may be logically inverted to facilitate integration of the relay within the user scheme. When inverted the relay indicates that the BI is energised when no d.c. is applied. Inversion occurs before the PU & DO time delay, see fig. 2.8-1.

Each input may be mapped to any front Fascia indication LED and/or to any Binary output contact and can also be used with the internal user programmable logic. This allows the relay to provide panel indications and alarms.

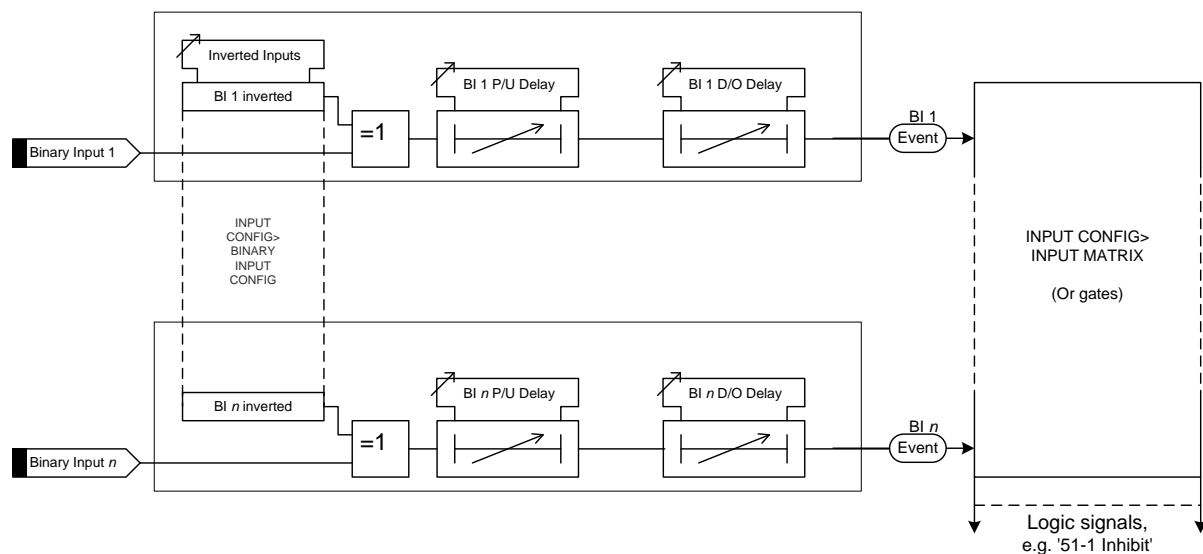

Figure 2-2 Binary Input Logic

2.9 Binary outputs (Output Relays)

Relays are fitted with 6 or 14 binary outputs. All outputs are fully user configurable and can be programmed to operate from any or all of the available functions.

The Power Supply module includes the relay basic I/O. The module includes six binary outputs each fitted with 1 contact – providing in total 1 x normally closed (NC), 2 x change-over (CO) and 3 x normally open (NO) contacts.

In the default mode of operation binary outputs are self reset and remain energised for a user configurable minimum time of up to 60 seconds. If required, outputs can be programmed to operate as 'hand reset' or 'pulsed'. Where an output is programmed to be 'hand reset' and 'pulsed' then the output will be 'hand reset' only.

The binary outputs can be used to operate the trip coils of the circuit breaker directly where the trip coil current does not exceed the 'make and carry' contact rating. The circuit breaker auxiliary contacts or other in-series auxiliary device must be used to break the trip coil current.

CB1 and CB2 'Trip Contacts' are assigned in the OUTPUT CONFIG>BINARY OUTPUT CONFIG menu. Operation of a 'Trip Contact' will actuate the 'Trip Alert' screen where enabled and will initiate both fault record storage and CB Fail protection where enabled.

When the relay is withdrawn from the case all normally closed contacts will be open circuited. This should be considered in the design of the control and protection circuitry.

Notes on Self Reset Outputs

Outputs reset after the initiate condition is removed, they are subject to the user definable 'Minimum Operate Time' setting.

With a failed breaker condition the relay may remain operated until current flow in the primary system is interrupted by an upstream device. The relay will then reset and attempt to interrupt trip coil current flowing through an output contact. Where this level is above the break rating of the output contact an auxiliary relay with heavy-duty contacts should be utilised.

Notes on Pulsed Outputs

When operated, the output will reset after the user definable 'Minimum Operate Time' setting regardless of the initiating condition.

Notes on Hand Reset Outputs

Hand reset outputs can be reset by either pressing the **TEST/RESET▶** button, by energising a suitably programmed binary input, or, by sending an appropriate command over the data communications channel(s).

On loss of the auxiliary supply hand-reset outputs will reset. When the auxiliary supply is re-established the binary output will remain in the reset state unless the initiating condition is still present.

Binary Output Test

The MAINTENANCE>OUTPUT MATRIX TEST menu includes a facility to test output relays from the relay fascia without the need for a secondary injection test set.

Binary outputs can also be energised from the Reydisp Evolution software package where PC facilities are available.

For both methods the output contact is energised for the duration of the 'OUTPUT CONFIG > BINARY OUTPUT CONFIG > Min Operate Time' setting.

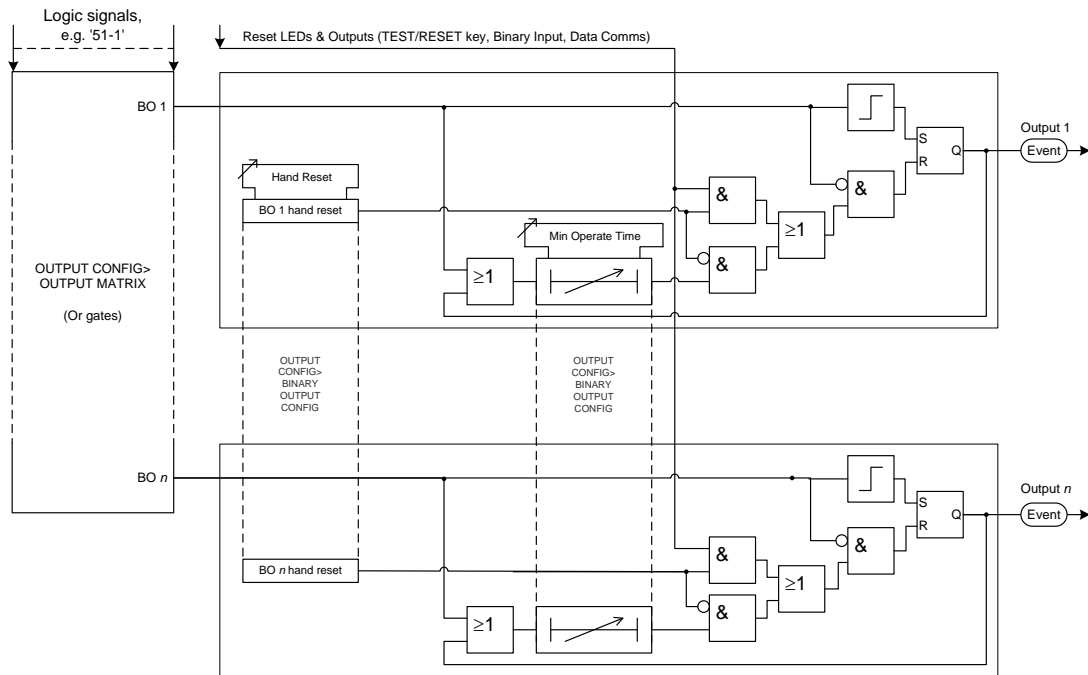

Figure 2-3 Binary Output Logic

2.10 Virtual Input/Outputs

The relays have 16 virtual input/outputs, these are internal logic states. Virtual I/O is assigned in the same way as physical Binary Inputs and Binary Outputs. Virtual I/O is mapped from within the INPUT CONFIG > INPUT MATRIX and OUTPUT CONFIG > OUTPUT MATRIX menus.

The status of virtual I/O is not stored during power loss.

2.11 Self Monitoring

The relay incorporates a number of self-monitoring features. Each of these features can initiate a controlled reset recovery sequence.

Supervision includes a power supply watchdog, code execution watchdog, memory checks by checksum and processor/ADC health checks. When all checks indicate the relay is operating correctly the 'Protection Healthy' LED is illuminated.

If an internal failure is detected, a message will be displayed. The relay will reset in an attempt to rectify the failure. This will result in de-energisation of any binary output mapped to 'protection healthy' and flashing of the protection healthy LED. If a successful reset is achieved by the relay the LED and output contact will revert back to normal operational mode, and the relay will restart, therefore ensuring the circuit is protected for the maximum time.

A Start-up Counter Meter is provided to display the number of start-ups the relay has performed. Once the number of start-ups has exceeded a set number, an Alarm output can be given.



Figure 2.11-1 Start-up Counter Meter

Reset of the counter can be done from the meter or via a binary input or a command.

Various types of start-up are monitored by the relay:

1. **power-on starts** (auxiliary supply initiation)
2. **expected starts** (user initiated via comms, language changes, custom protection curve etc.)
3. **unexpected starts** (caused by the relay watchdog)

Any combination of these can be selected for the start-up count. This is done in the MAINTENANCE MENU>START COUNT menu using the **Start Up Types** setting. All the start-up types selected will be added to the overall start-up count.

The number of restarts before the alarm output is raised is set in the MAINTENANCE MENU>START COUNT menu using the **Start Up Count Target** setting.

When the number of relay start-ups reaches the target value an output is raised, OUTPUT MATRIX>**Start Up Count Alarm**, which can be programmed to any combination of binary outputs, LED's or virtual outputs.

2.11.1 Protection Healthy/Defective

A normally open contact can be used to signal protection healthy. When the relay has DC supply and it has successfully passed its self-checking procedure then the Protection Healthy contacts are made.

A normally closed contact is used to signal protection defective. When the DC supply is not applied to the relay or a problem is detected within the relay then this output is de-energised and the normally closed contacts make to provide an external alarm.

An alarm can be provided if the relay is withdrawn from the case. A contact is provided in the case at positions 25-26 of the PSU module, this contact closes when the relay is withdrawn.

Section 3: Protection Functions

3.1 Current Protection: Differential Protection

Comprises both biased differential and high-set differential elements.

The fundamental frequency current is measured with the line CT inputs. These line currents are both multiplied and vector corrected before being applied to the current differential elements.

3.1.1 ICT

The ***Wn ICT Multiplier*** setting is applied to the line currents – the CT secondary currents. The multiplier is used to correct any CT ratio mismatch so that ideally nominal current ($ICT_{OUT} = 1A$) is applied to the biased differential algorithm.

The ***Wn ICT Connection*** setting applies the correct vector compensation to the current applied to the differential algorithm.

The nominal current ratio of the virtual interposing CT is 1:1. Note that where Yd settings are applied some current distributions will result in a $\sqrt{3}$ multiplying factor being applied. See 'Applications Guide'.

3.1.2 Overall Biased Differential (87BD)

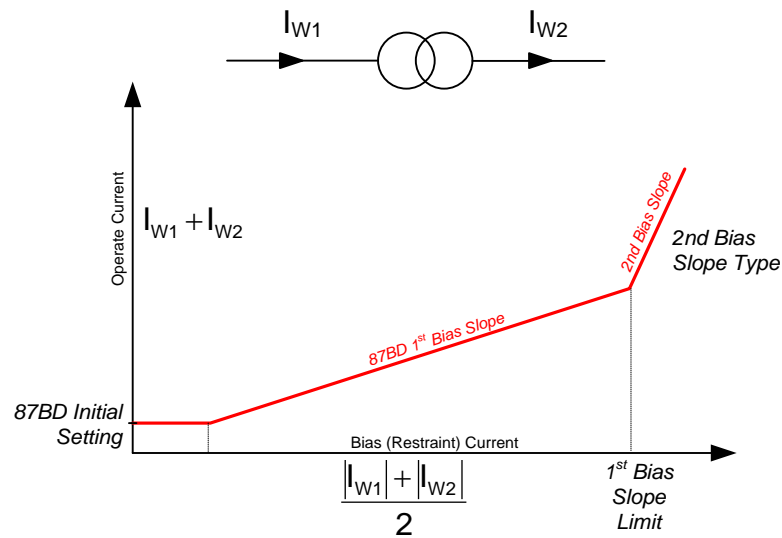

Figure 3-1 Biased Differential Characteristic

Figure 3.1-1 illustrates the biased differential characteristic. Within the relay the fundamental frequency RMS line currents are modified by the **ICT Multiplier** and **ICT Connection** settings (see 3.1.1) before being applied to the biased differential elements. The biased differential elements calculate the operate current for each phase from the vector sum of winding 1 and winding 2 currents i.e. $I_{OPERATE} = I_{W1} + I_{W2}$. The bias (or restraint) current is calculated from the total current of winding 1 and winding 2 currents i.e. $I_{RESTRAIN} = \frac{|I_{W1}| + |I_{W2}|}{2}$.

The **87BD Initial** setting defines the minimum differential current required to operate the relay.

The **87BD 1st Bias Slope** setting is used to ensure protection stability in the presence of steady state errors e.g. the effects of an on-load tap changer.

The **87BD 1st Bias Slope Limit** setting defines the border between the 1st and 2nd bias slopes.

87BD 2nd Bias Slope Type setting allows the user to select the preferred characteristic shape i.e. **Line** or **Curve**.

The **87BD 2nd Bias Slope** setting is applied when **87BD 2nd Bias Slope Type = Line**. This setting is used to modify the sensitivity of the differential algorithm at higher current levels.

The output of **87BD Delay** can be mapped to relay outputs.

Operation of the biased differential elements can be inhibited from:

Inhibit 87BD	A binary or virtual input.
87BD Inrush Action: Inhibit	Operation of the inrush current detector
87BD Overfluxing Action: Inhibit	Operation of the overfluxing detector
User Inhibit	Reylogic (graphical logic).

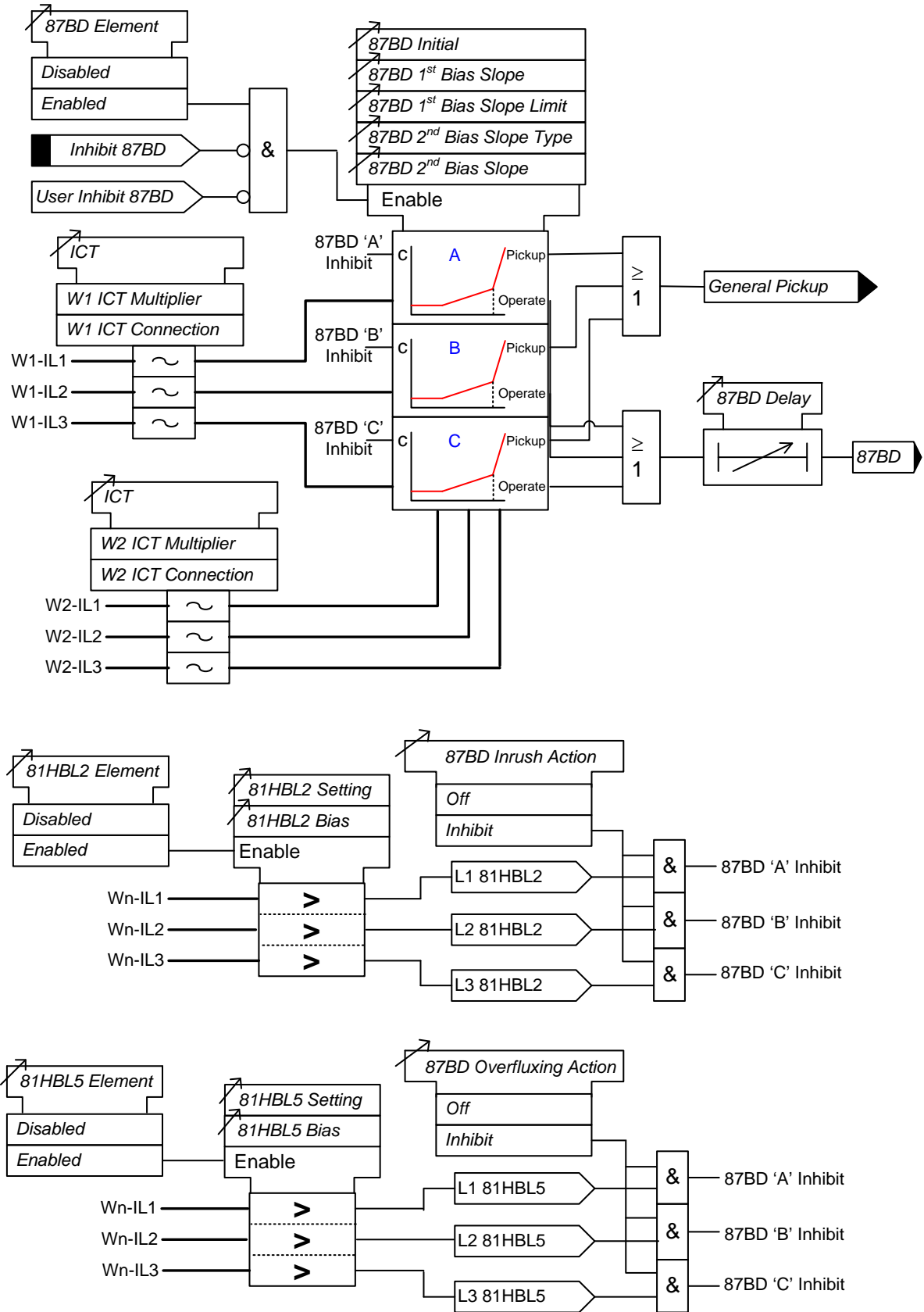

Figure 3-2 Functional Diagram for Biased Current Differential Protection

3.1.3 87HS

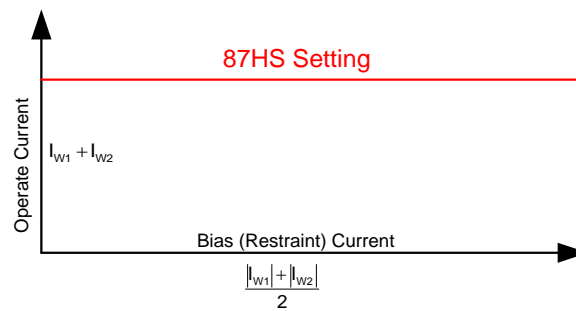

Figure 3-3 Differential Highset Characteristic

Figure 3.1-3 illustrates the differential highset characteristic. Within the relay the fundamental frequency RMS line currents are modified by the **ICT Multiplier** and **ICT Connection** settings (see 3.1.1) before being applied to the differential highset elements. The differential highset elements calculate the operate current for each phase from the vector sum of winding 1 and winding 2 currents i.e. $I_{OPERATE} = I_{W1} + I_{W2}$.

87HS Setting defines the differential current required to operate the element. The output of **87HS Delay** can be mapped to relay outputs.

Operation of the highset differential elements can be inhibited from:

Inhibit 87HS	A binary or virtual input.
87HS Inrush Action: Inhibit	Operation of the inrush current detector
87HS Overfluxing Action: Inhibit	Operation of the overfluxing detector
User Inhibit	Reylogic (graphical logic).

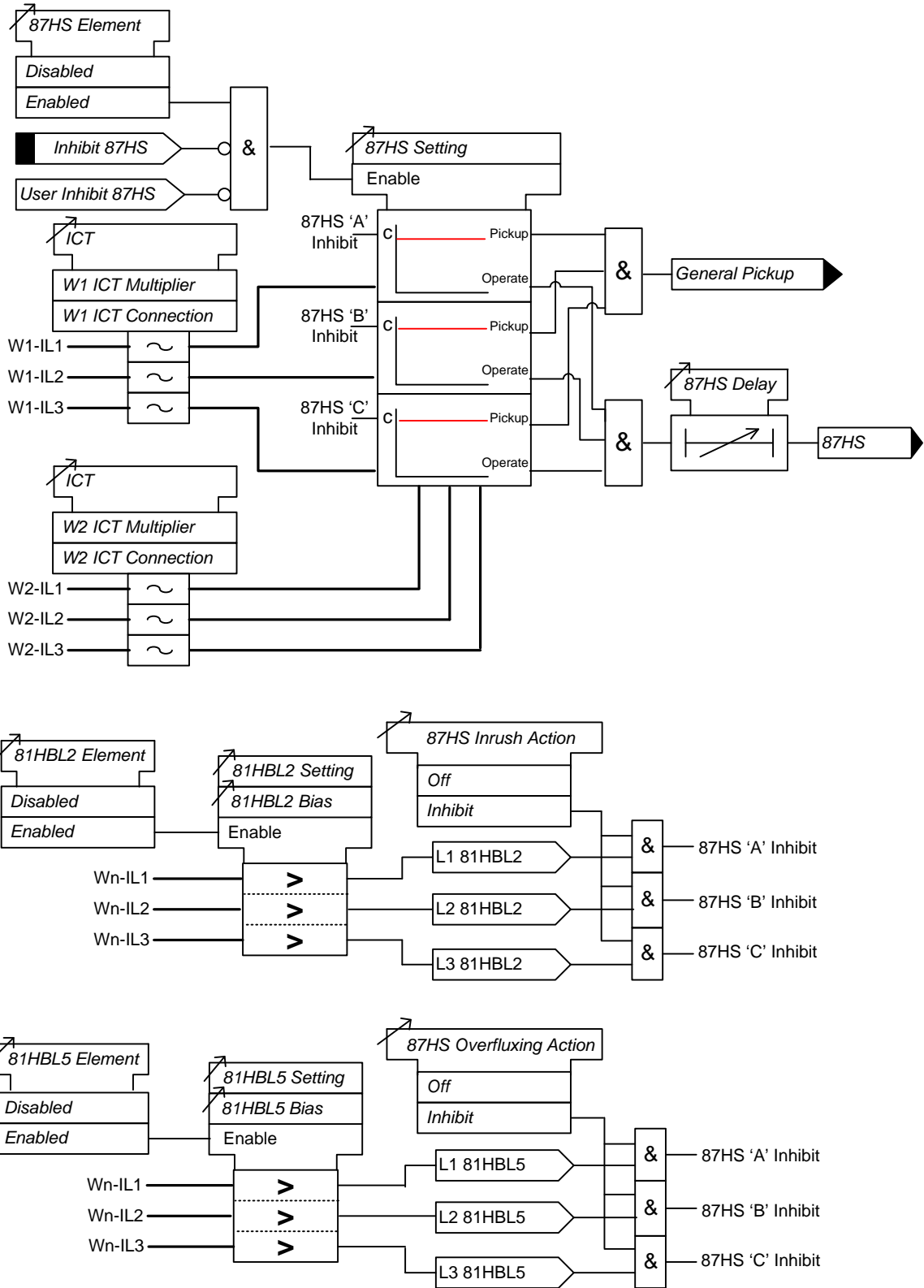

Figure 3-4 Logic Diagram: High Set Current Differential Protection

3.2 Current Protection: Phase Overcurrent (51, 50)

The optional phase overcurrent elements have a common setting to measure either fundamental frequency RMS or True RMS current:

True RMS current: **51/50 Measurement = RMS**

Fundamental Frequency RMS current: **51/50 Measurement = Fundamental**

3.2.1 Instantaneous Overcurrent Protection (50)

Optionally two instantaneous overcurrent elements are provided, each can be selected to either winding 1 or winding 2.

Each instantaneous element (50-n) has independent settings. **50-n Setting** for pick-up current and **50-n Delay** follower time delay. The instantaneous elements have transient free operation.

Operation of the instantaneous overcurrent elements can be inhibited from:

Inhibit 50-n	A binary or virtual input.
50-n Inrush Action: Inhibit	Operation of the inrush detector function.
User Inhibit	Reylogic (graphical logic).

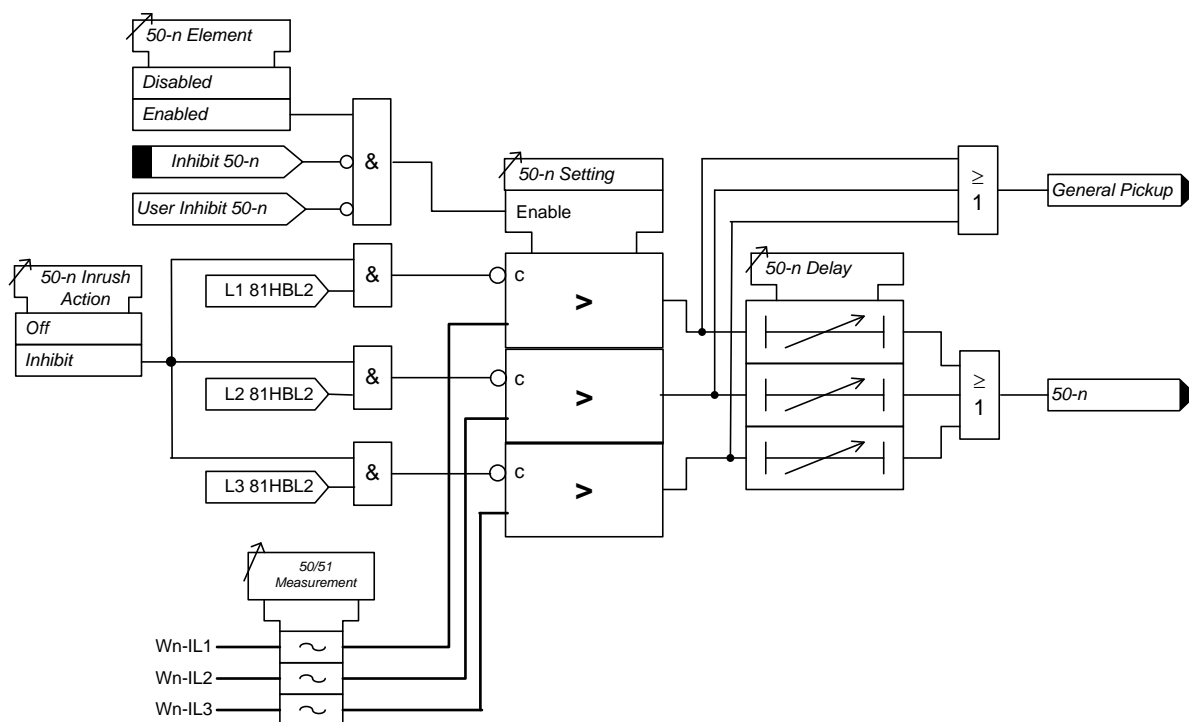

Figure 3-5 Logic Diagram: Instantaneous Over-current Element

3.2.2 Time Delayed Overcurrent Protection (51)

Optionally two time delayed overcurrent elements are provided, each can be selected to either winding 1 or winding 2.

51-n Setting sets the pick-up current level.

A number of shaped characteristics are provided. An inverse definite minimum time (IDMT) characteristic is selected from IEC, ANSI or user defined curves using **51-n Char**. A time multiplier is applied to the characteristic curves using the **51-n Time Mult** setting. Alternatively, a definite time lag delay (DTL) can be chosen using **51-n Char**. When Delay (DTL) is selected the time multiplier is not applied and the **51-n Delay (DTL)** setting is used instead. The full list of operating curves is given in Chapter 2 – ‘Settings, Configuration and Instruments Guide’. Operating curve characteristics are illustrated in Chapter 3 – ‘Performance Specification’.

The **51-n Reset** setting can apply a **definite time delayed** reset, or when configured as an ANSI characteristic an **ANSI (DECAYING)** reset. If ANSI (DECAYING) reset is selected for an IEC characteristic, the reset will be instantaneous. The reset mode is significant where the characteristic has reset before issuing a trip output – see ‘Applications Guide’.

A minimum operate time for the characteristic can be set using **51-n Min. Operate Time** setting.

A fixed additional operate time can be added to the characteristic using **51-n Follower DTL** setting.

Operation of the time delayed overcurrent elements can be inhibited from:

- Inhibit 51-n** A binary or virtual input.
- 51-n Inrush Action: Inhibit** Operation of the inrush detector function.
- User Inhibit** Relaylogic (graphical logic).

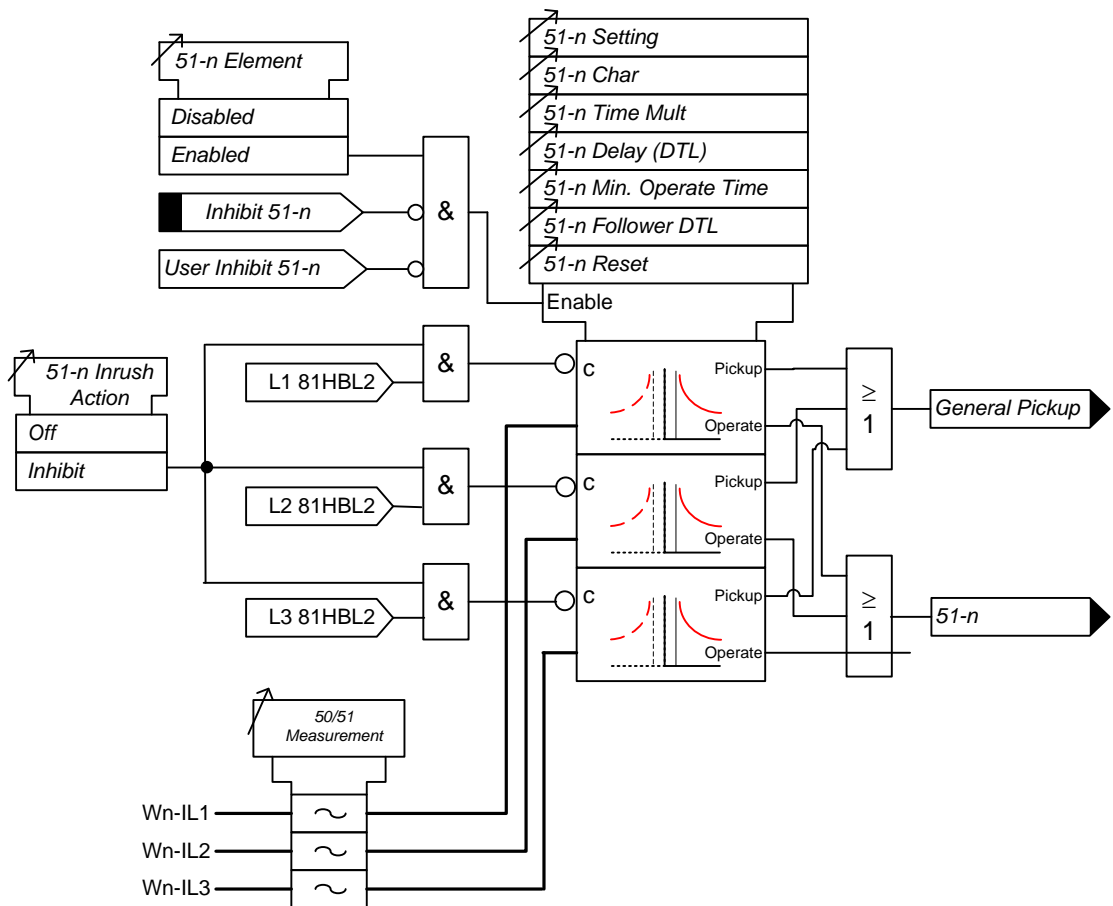

Figure 3-6 Logic Diagram: Time Delayed Overcurrent Element

3.3 Current Protection: Derived Earth Fault (50N, 51N)

The earth current is derived by calculating the sum of the measured line currents. These optional elements utilise RMS current values of the fundamental frequency (50 or 60Hz).

3.3.1 Instantaneous Derived Earth Fault Protection (50N)

Optionally two instantaneous derived earth fault elements are provided, each can be selected to either winding 1 or winding 2.

Each instantaneous element has independent settings for pick-up current **50N-n Setting** and a follower time delay **50N-n Delay**. The instantaneous elements have transient free operation.

Operation of the instantaneous earth fault elements can be inhibited from:

Inhibit 50N-nt	A binary or virtual input.
50N-n Inrush Action: Inhibit	Operation of the inrush detector function.
User Inhibit	Reylogic (graphical logic).

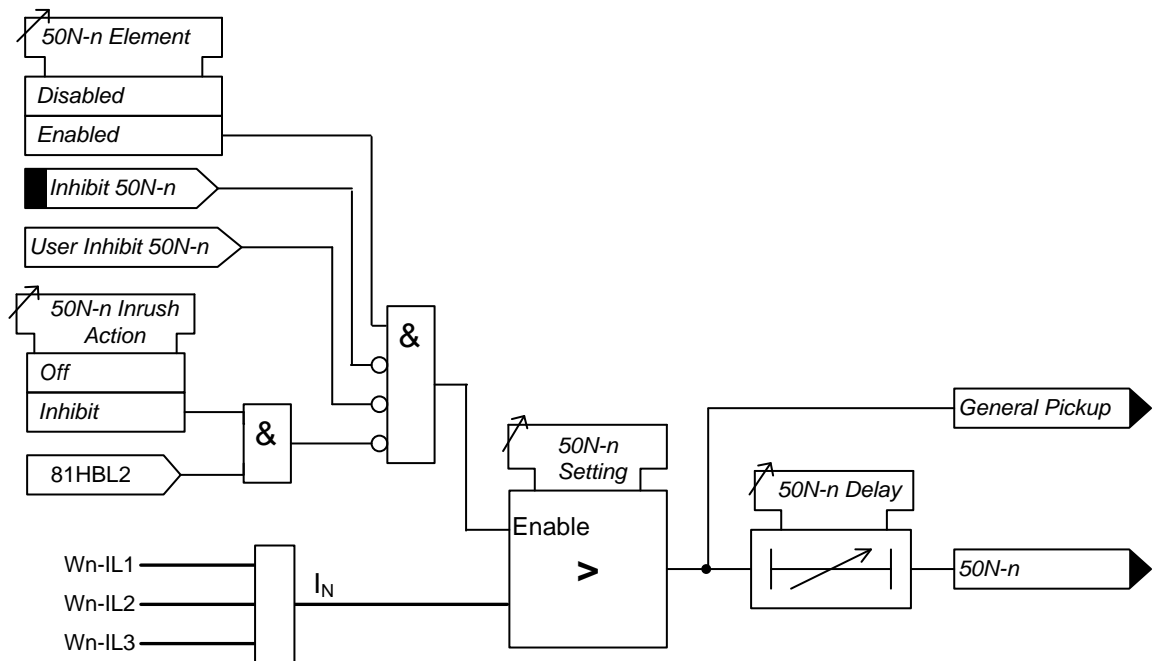

Figure 3-7 Logic Diagram: Instantaneous Derived Earth Fault Element

3.3.2 Time Delayed Derived Earth Fault Protection (51N)

Optionally two time delayed derived earth fault elements are provided, each can be selected to either winding 1 or winding 2.

51N-n Setting sets the pick-up current level.

A number of shaped characteristics are provided. An inverse definite minimum time (IDMT) characteristic is selected from IEC, ANSI or user defined curves using **51N-n Char**. A time multiplier is applied to the characteristic curves using the **51N-n Time Mult** setting. Alternatively, a definite time lag delay (DTL) can be chosen using **51N-n Char**. When Delay (DTL) is selected the time multiplier is not applied and the **51N-n Delay (DTL)** setting is used instead.

The **51N-n Reset** setting can apply a **definite time delayed** or **ANSI (DECAYING)** reset. The reset mode is significant where the characteristic has reset before issuing a trip output – see 'Applications Guide'.

A minimum operate time for the characteristic can be set using the **51N-n Min. Operate Time** setting.

A fixed additional operate time can be added to the characteristic using the **51N-n Follower DTL** setting.

Operation of the time delayed earth fault elements can be inhibited from:

- Inhibit 51N-n** A binary or virtual input.
- 51N-n Inrush Action: Inhibit** Operation of the inrush detector function.
- User Inhibit** Relaylogic (graphical logic).

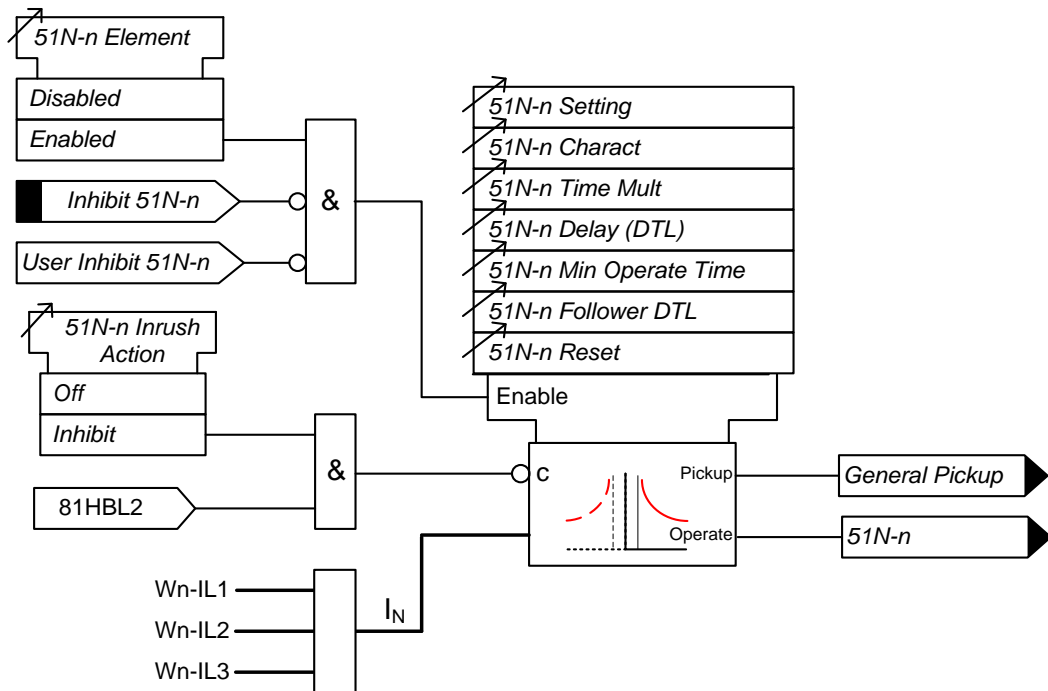

Figure 3-8 Logic Diagram: Derived Time Delayed Earth Fault Protection

3.4 Current Protection: Measured Earth Fault (50G, 51G)

The earth current is measured directly via dedicated current analogue inputs. These optional elements utilise either RMS or Fundamental current values as defined by the **51G/50G Measurement** setting (MEASURED E/F menu).

3.4.1 Instantaneous Measured Earth Fault Protection (50G)

Optionally two instantaneous measured earth fault elements are provided, each can be selected to either winding 1 or winding 2.

Each instantaneous element has independent settings for pick-up current **50G-n Setting** and a follower time delay **50G-n Delay**. The instantaneous elements have transient free operation.

Operation of the instantaneous measured earth fault elements can be inhibited from:

Inhibit 50G-n	A binary or virtual input.
50G-n Inrush Action: Inhibit	Operation of the inrush detector function.
User Inhibit	Reylogic (graphical logic).

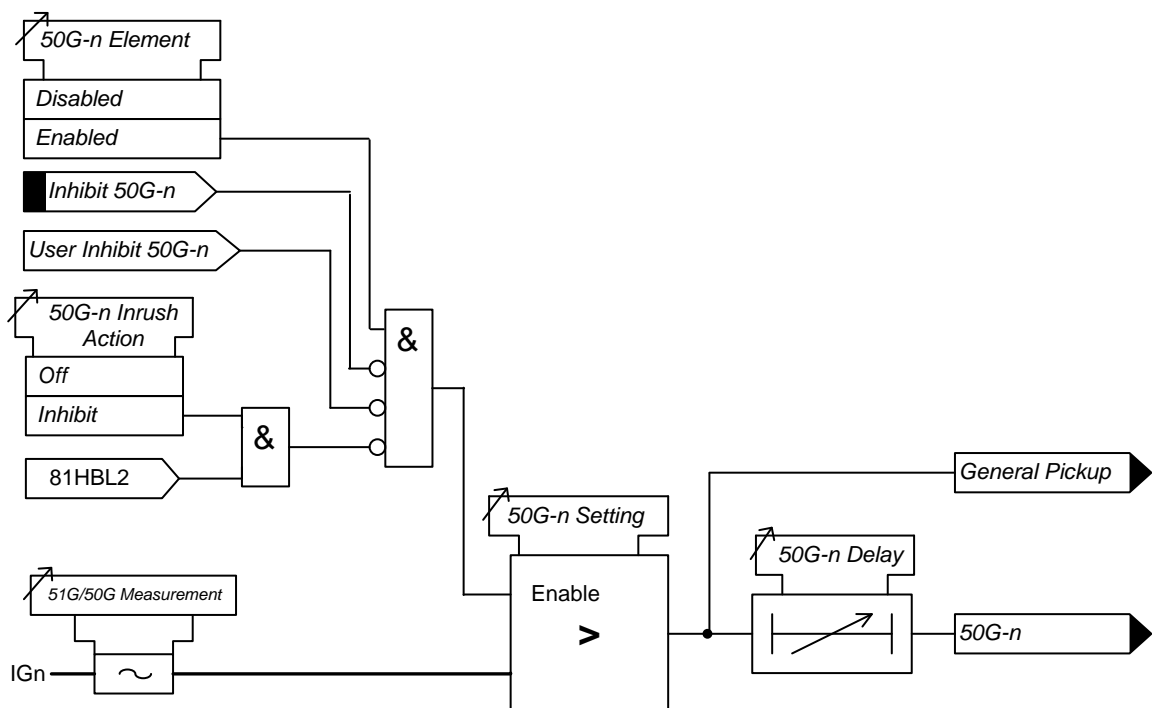

Figure 3-9 Logic Diagram: Measured Instantaneous Earth-fault Element

3.4.2 Time Delayed Measured Earth Fault Protection (51G)

Optionally two time delayed measured earth fault elements are provided, each can be selected to either winding 1 or winding 2.

51G-n Setting sets the pick-up current level.

A number of shaped characteristics are provided. An inverse definite minimum time (IDMT) characteristic is selected from IEC, ANSI or user defined curves using **51G-n Char**. A time multiplier is applied to the characteristic curves using the **51G-n Time Mult** setting. Alternatively, a definite time lag (DTL) can be chosen using **51G-n Char**. When DTL is selected the time multiplier is not applied and the **51G-n Delay (DTL)** setting is used instead.

The **51G-n Reset** setting can apply a **definite time delayed** or **ANSI (DECAYING)** reset. The reset mode is significant where the characteristic has reset before issuing a trip output – see 'Applications Guide'.

A minimum operate time for the characteristic can be set using **51G-n Min. Operate Time** setting.

A fixed additional operate time can be added to the characteristic using **51G-n Follower DTL** setting.

Operation of the time delayed measured earth fault elements can be inhibited from:

Inhibit 51G-n	A binary or virtual input.
51G-n Inrush Action: Inhibit	Operation of the inrush detector function.
User Inhibit	Reylogic (graphical logic).

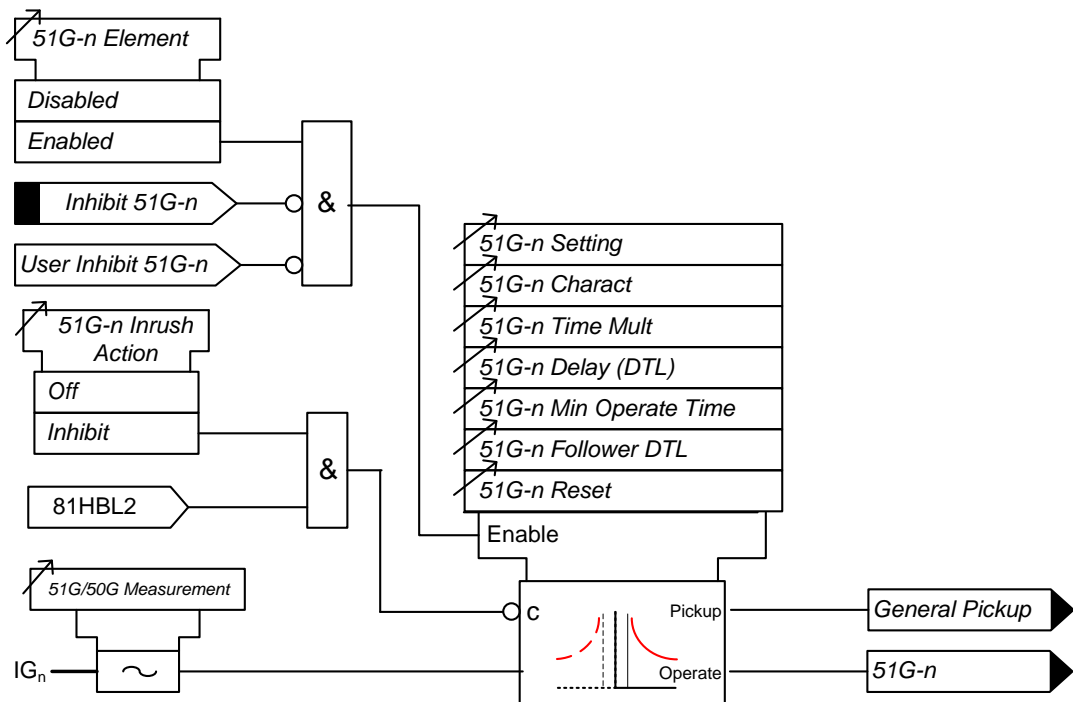

Figure 3-10 Logic Diagram: Time Delayed Measured Earth Fault Element (51G)

3.5 Current Protection: High Impedance Restricted Earth Fault (64H)

Two high impedance restricted earth fault elements are provided, one for each transformer winding

The relay utilises fundamental current measurement values for this function.

The single phase current input is derived from the residual output of line/neutral CTs connected in parallel. An external stabilising resistor must be connected in series with this input to ensure that this element provides a high impedance path.

64H Current Setting sets the pick-up current level. An output is given after elapse of the **64H Delay** setting.

An external series stabilising resistor and a parallel connected voltage limiting non-linear resistor are used with this function. See 'Applications Guide' for advice in specifying suitable component values.

Operation of the high impedance element can be inhibited from:

Inhibit 64H	A binary or virtual input.
User Inhibit	Reylogic (graphical logic).

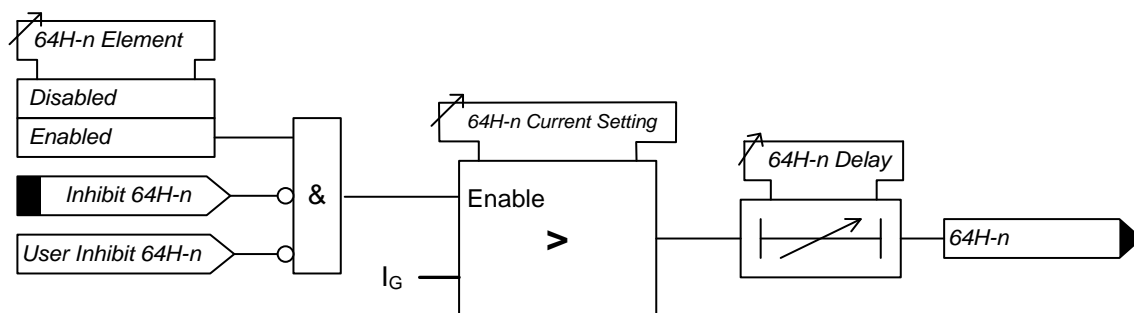

Figure 3-11 Logic Diagram: High Impedance REF (64H)

3.6 Open Circuit (46BC)

Optionally two open circuit elements are provided, each can be selected to either winding 1 or winding 2.

The element calculates the ratio of NPS to PPS currents. Where the NPS:PPS current ratio is above **46BC Setting** an output is given after the **46BC Delay**.

The Open Circuit function can be inhibited from

- Inhibit 46BC** A binary or virtual input .
- Gn 46BC-n U/I Guarded** Operation of the undercurrent guard function.
- User Inhibit** Reylogic (graphical logic).

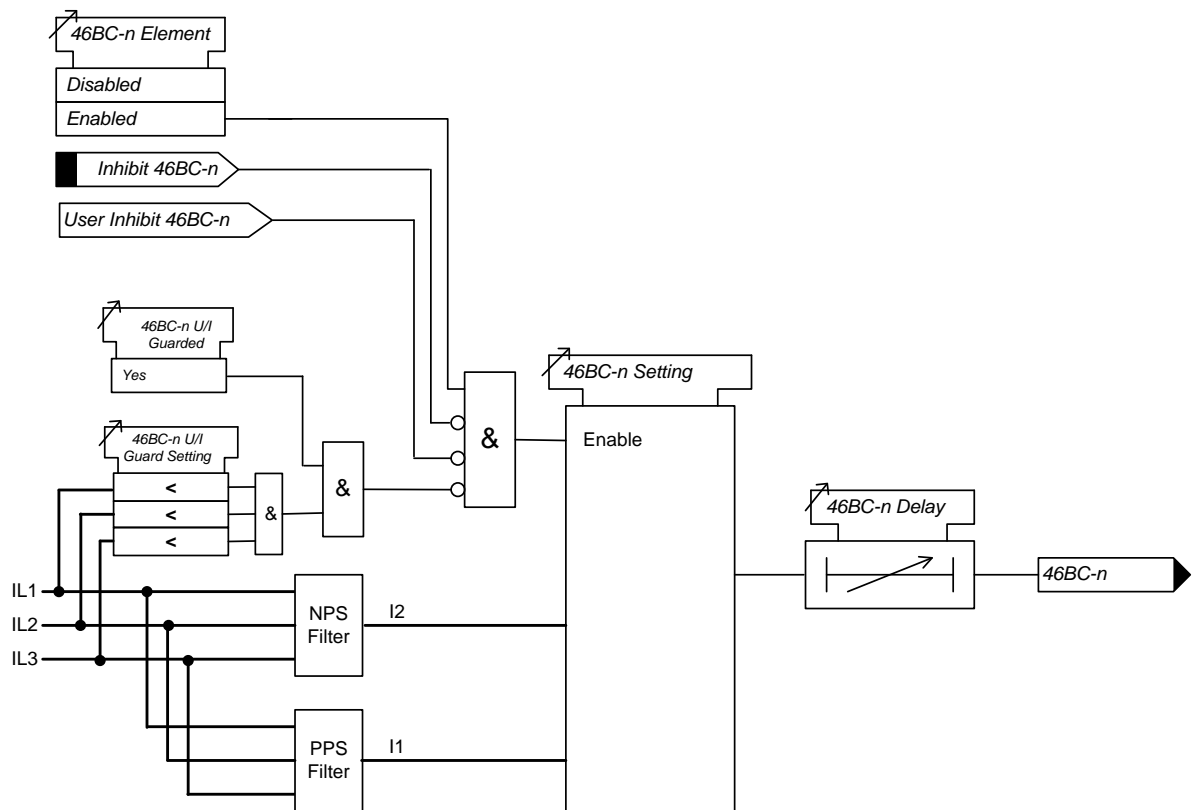

Figure 3-12 Logic Diagram: Open Circuit Function (46BC)

3.7 Current Protection: Negative Phase Sequence Overcurrent (46NPS)

Optionally four NPS current elements are provided – 2 x 46IT and 2 x 46DT. Each element can be selected to either winding 1 or winding 2.

The 46IT elements can be configured to be either definite time lag (DTL) or inverse definite minimum time (IDMT), **46IT Setting** sets the pick-up current level for the element.

A number of shaped characteristics are provided. An inverse definite minimum time (IDMT) characteristic is selected from IEC and ANSI curves using **46IT Char**. A time multiplier is applied to the characteristic curves using the **46IT Time Mult** setting. Alternatively, a definite time lag delay (DTL) can be chosen using **46ITChar**. When Delay (DTL) is selected the time multiplier is not applied and the **46IT Delay (DTL)** setting is used instead.

The **46IT Reset** setting can apply a, **definite time delayed** or **ANSI (DECAYING)** reset.

The 46DT elements have a DTL characteristic. **46DT Setting** sets the pick-up current and **46DT Delay** the follower time delay.

Operation of the negative phase sequence overcurrent elements can be inhibited from:

Inhibit 46IT	A binary or virtual input.
Inhibit 46DT	A binary or virtual input.
User Inhibit	Reylogic (graphical logic).

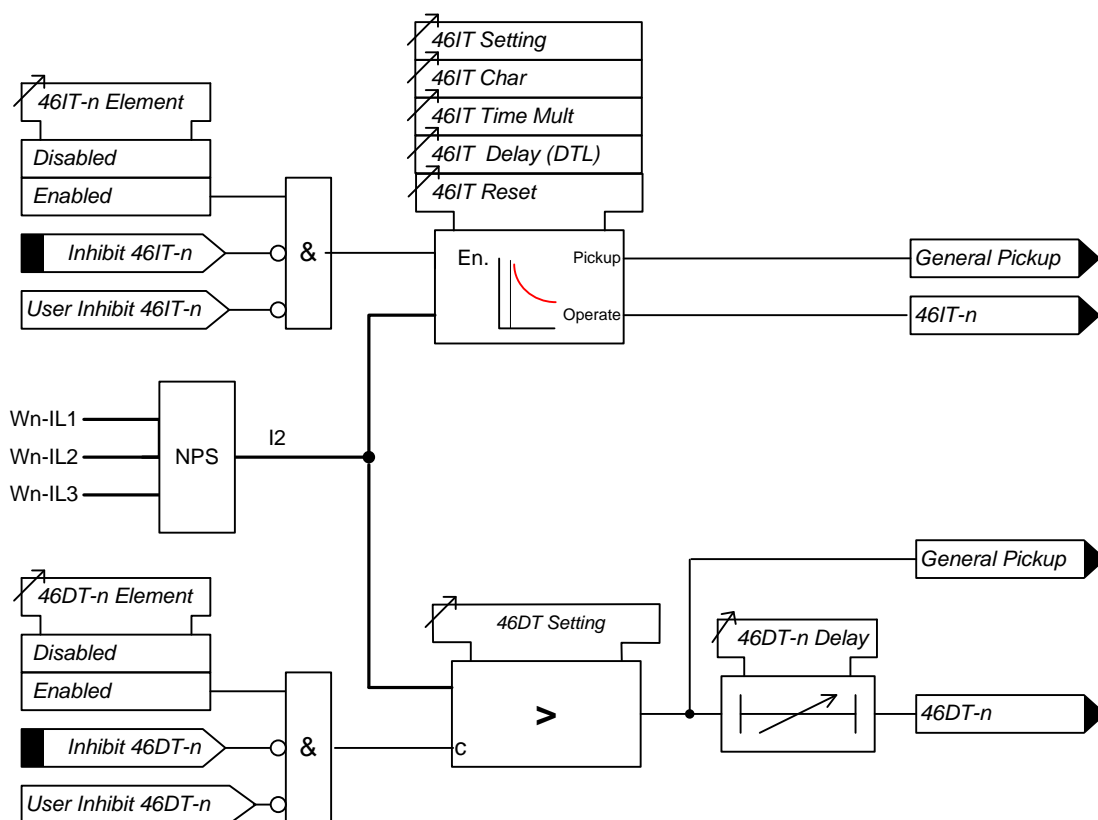

Figure 3-13 Logic Diagram: Negative Phase Sequence Overcurrent (46NPS)

3.8 Current Protection: Under-Current (37, 37G)

Optionally two under-current elements are provided for both line and measured earth current, each can be selected to either winding 1 or winding 2.

Each phase has an independent level detector and current-timing element. **37-n Setting** sets the pick-up current. An output is given after elapse of the **37-n Delay** setting.

Operation of the under-current elements can be inhibited from:

Inhibit 37(G)-n	A binary or virtual input.
Gn 37-n U/I Guarded	Operation of the undercurrent guard function.
Inhibit 37(G)-n	A binary or virtual input.
User Inhibit 37(G)-n	Reylogic (graphical logic).

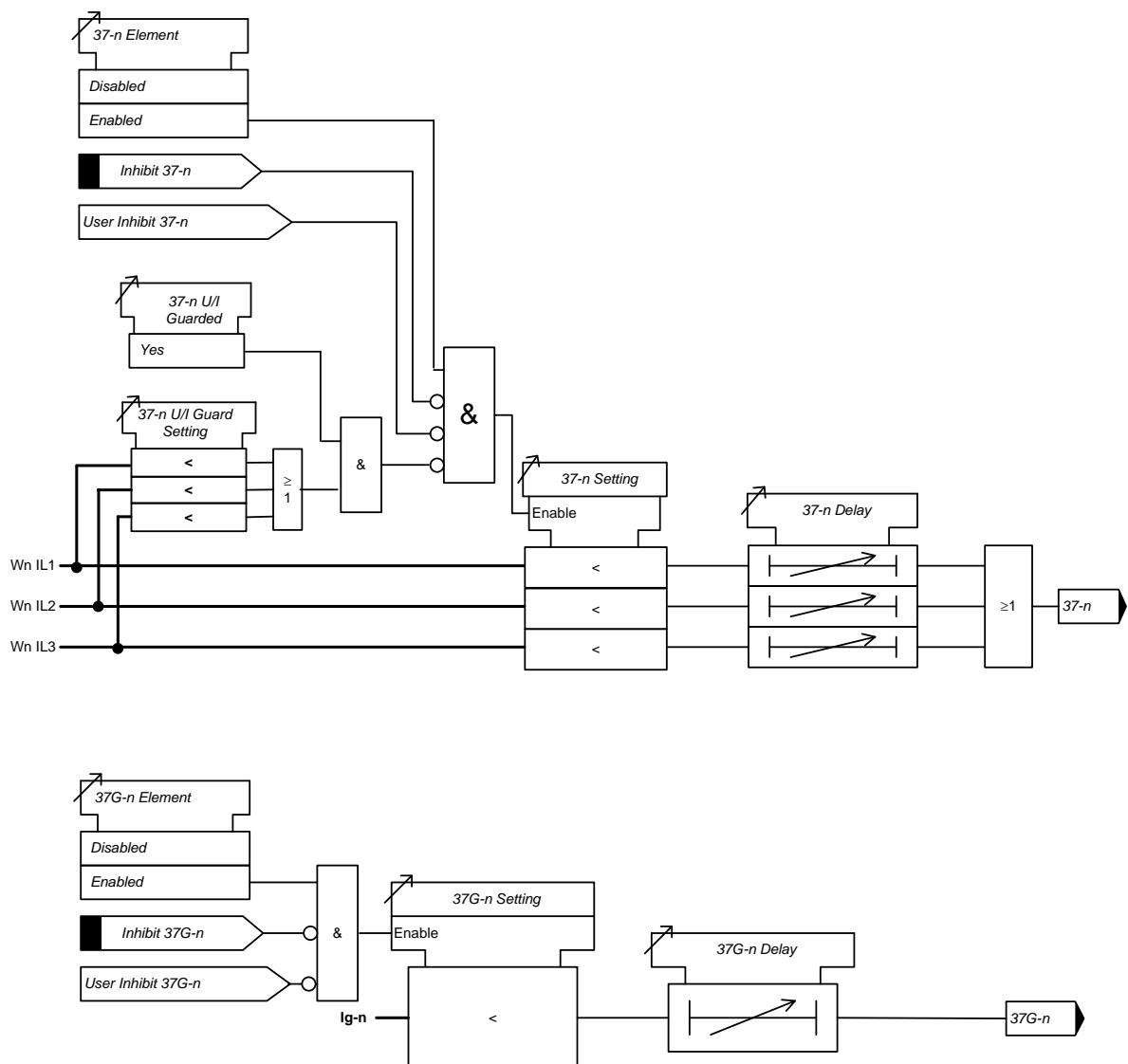

Figure 3-14 Logic Diagram: Undercurrent Detector (37, 37G)

3.9 Current Protection: Thermal Overload (49)

Optionally a phase segregated thermal overload element is provided, this can be selected to either winding 1 or winding 2. The thermal state is calculated using the measured True RMS current.

Should the current rise above the **49 Overload Setting** for a defined time an output signal will be initiated.

Operate Time (t):-

$$t = \tau \times \ln \left\{ \frac{I^2 - I_P^2}{I^2 - (k \times I_B)^2} \right\}$$

Where

T = Time in minutes

τ = **49 Time Constant** setting (minutes)

ln = Log Natural

I = measured current

I_P = Previous steady state current level

k = Constant

I_B = Basic current, typically the same as I_n

$k \cdot I_B$ = **49 Overload** Setting (I_θ)

Additionally, an alarm can be given if the thermal state of the system exceeds a specified percentage of the protected equipment's thermal capacity **49 Capacity Alarm** setting.

For the heating curve:

$$\theta = \frac{I^2}{I_\theta^2} \cdot (1 - e^{-t/\tau}) \times 100\%$$

Where: θ = thermal state at time t

I = measured thermal current

I_θ = **49 Overload** setting (or $k \cdot I_B$)

The final steady state thermal condition can be predicted for any steady state value of input current where $t > \tau$,

$$\theta_F = \frac{I^2}{I_\theta^2} \times 100\%$$

Where: θ_F = final thermal state before disconnection of device

49 Overload Setting I_θ is expressed as a multiple of the relay nominal current and is equivalent to the factor $k \cdot I_B$ as defined in the IEC255-8 thermal operating characteristics. It is the value of current above which 100% of thermal capacity will be reached after a period of time and it is therefore normally set slightly above the full load current of the protected device.

The thermal state may be reset from the fascia, a user logic reset or externally via a binary input.

Thermal overload protection can be inhibited from:

Inhibit 49 A binary or virtual input.

User Inhibit Reylogic (graphical logic).

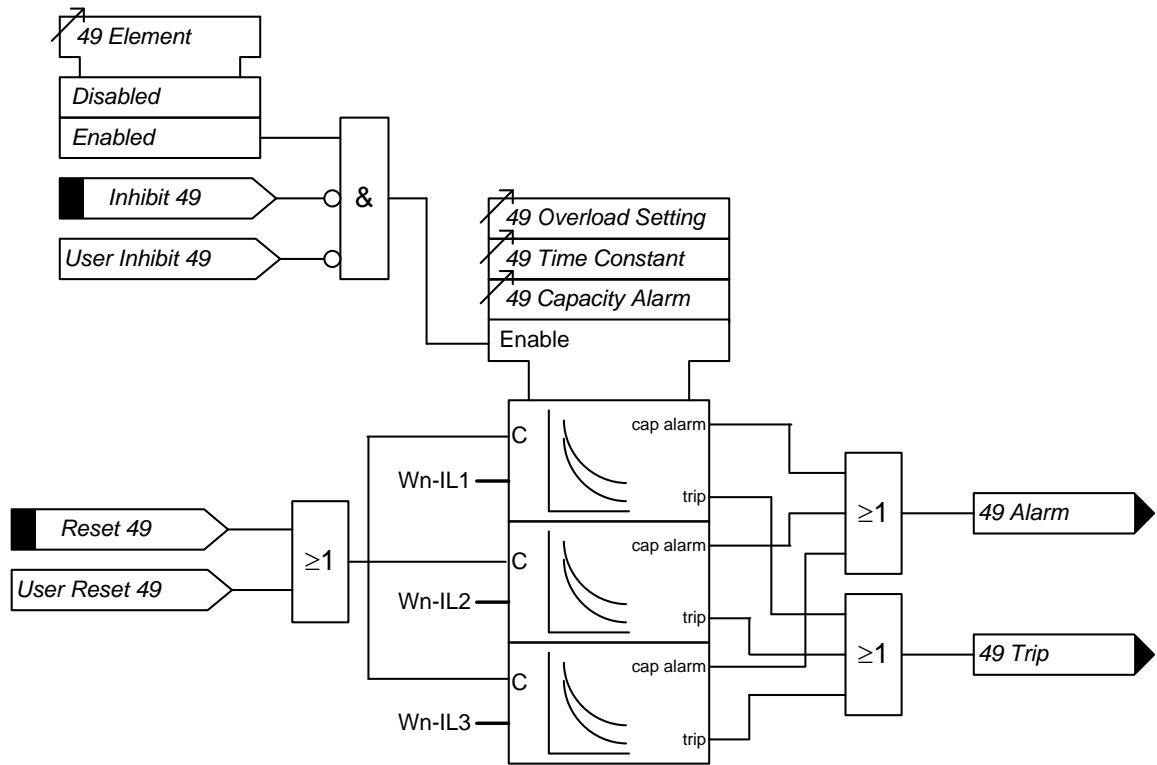

Figure 3-15 Logic Diagram: Thermal Overload Protection (49)

3.10 Voltage Protection: Over Fluxing (24)

Optionally, three over fluxing elements are provided – 2 x 24DT and 1 x 24IT Char elements.

The 24DT Elements have a DTL characteristic. **24DT Setting** sets the pick-up level and **24DT Delay** the follower time delay. An output is given if the Volts/Hertz ratio is above setting for the duration of the delay. The **24DT-n Hysteresis** setting allows the user to vary the pick-up/drop-off ratio for the element.

The 24IT Element has a user definable shape.

24Xn Point Setting sets the over fluxing (V/f) level for up to 7 user definable points.

24Yn Point Setting sets the operate time for each of the defined points.

The **24IT Reset** setting can apply a, **definite time delayed** reset.

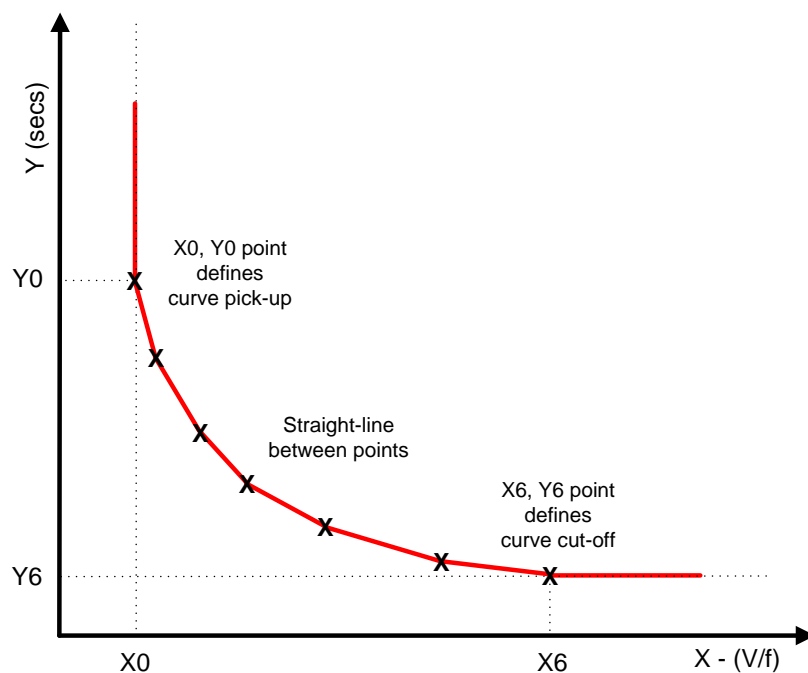

Figure 3-16 Inverse Over-fluxing Characteristic (24IT)

Operation of the over fluxing elements can be inhibited from:

Inhibit 24IT	A binary or virtual input.
Inhibit 24DT-n	A binary or virtual input.
User Inhibit	Reylogic (graphical logic).

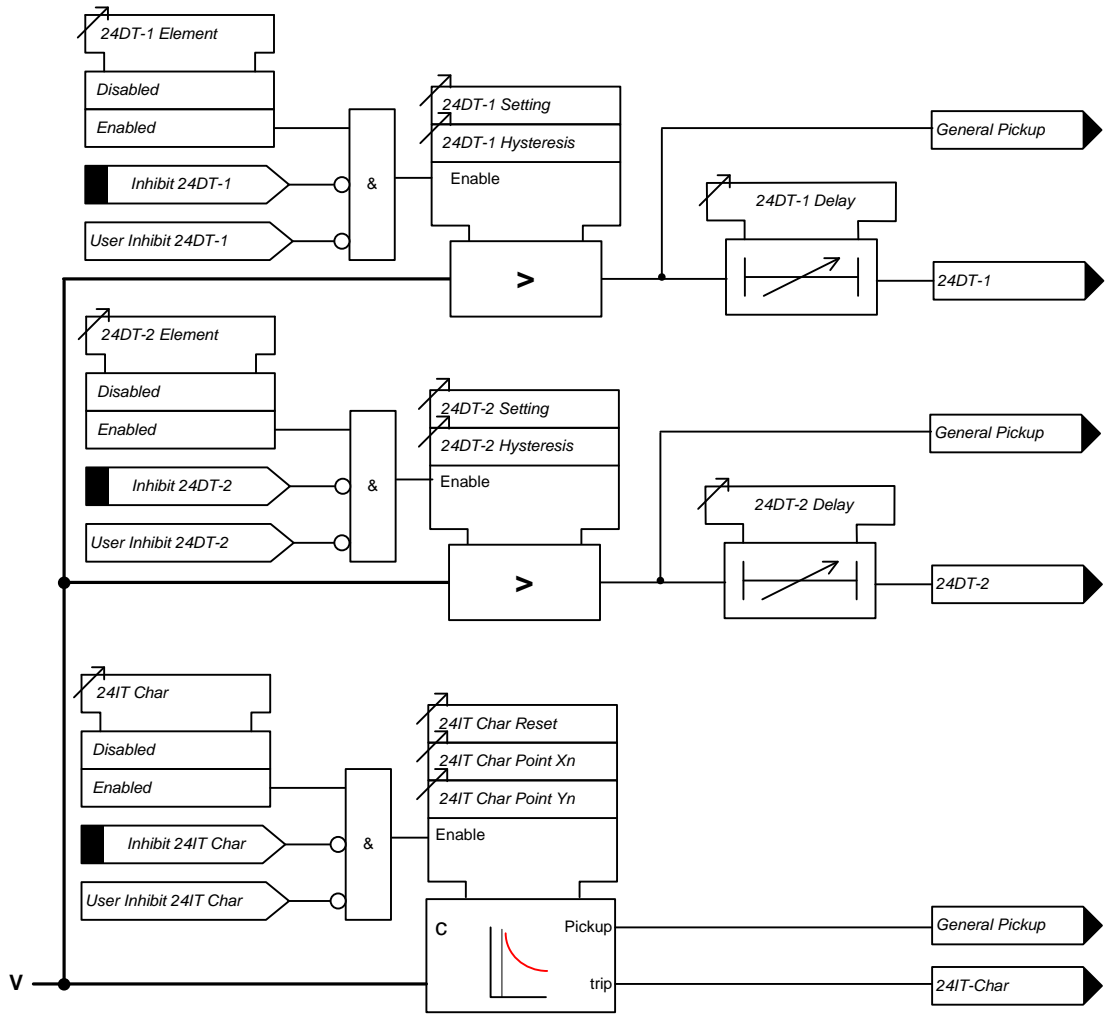

Figure 3-17 Logic Diagram: Overfluxing Elements (24)

3.11 Voltage Protection: Under/Over Voltage (27/59)

Optionally four under/over voltage elements are provided.

The relay utilises fundamental voltage measurement values for this function.

27/59-n Setting sets the pick-up voltage level for the element.

The sense of the element (undervoltage or overvoltage) is set by the **27/59-n Operation** setting.

Voltage elements are blocked if the measured voltage falls below the **27/59 U/V Guard** setting.

An output is given after elapse of the **27/59-n Delay** setting.

The **27/59-n Hysteresis** setting allows the user to vary the pick-up/drop-off ratio for the element.

Operation of the under/over voltage elements can be inhibited from:

Inhibit 27/59-n	A binary or virtual input.
27/59-n U/V Guarded	Under voltage guard element.
User Inhibit	Reylogic (graphical logic).

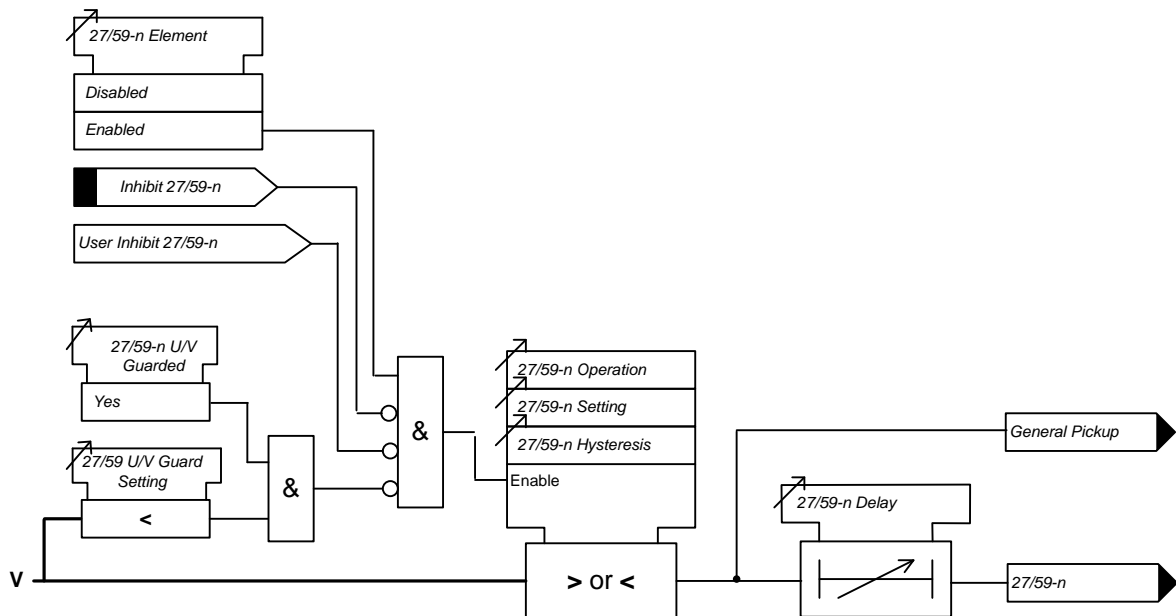

Figure 3-18 Logic Diagram: Under/Over Voltage Elements (27/59)

3.12 Voltage Protection: Neutral Overvoltage (59N)

Optionally two Neutral Overvoltage (or Neutral Voltage Displacement) elements are provided.

One of the elements can be configured to be either definite time lag (DTL) or inverse definite minimum time (IDMT),

59NIT Setting sets the pick-up voltage level ($3V_0$) for the element.

An inverse definite minimum time (IDMT) can be selected using **59NIT Char**. A time multiplier is applied to the characteristic curves using the **59NIT Time Mult** setting (M):

$$t_{op} = \left[\frac{M}{\left[\frac{3V_0}{V_s} \right] - 1} \right]$$

Alternatively, a definite time lag delay (DTL) can be chosen using **59NITChar**. When Delay (DTL) is selected the time multiplier is not applied and the **59NIT Delay (DTL)** setting is used instead.

An instantaneous or definite time delayed reset can be applied using the **59NIT Reset** setting.

The second element has a DTL characteristic. **59NDT Setting** sets the pick-up voltage ($3V_0$) and **59NDT Delay** the follower time delay.

Operation of the neutral overvoltage elements can be inhibited from:

- Inhibit 59NIT** A binary or virtual input.
- Inhibit59NDT** A binary or virtual input.
- User Inhibit** Reylogic (graphical logic).

It should be noted that neutral voltage displacement can only be applied to VT arrangements that allow zero sequence flux to flow in the core i.e. a 5-limb VT or 3 single phase VTs. The VT primary winding neutral must be earthed to allow the flow of zero sequence current.

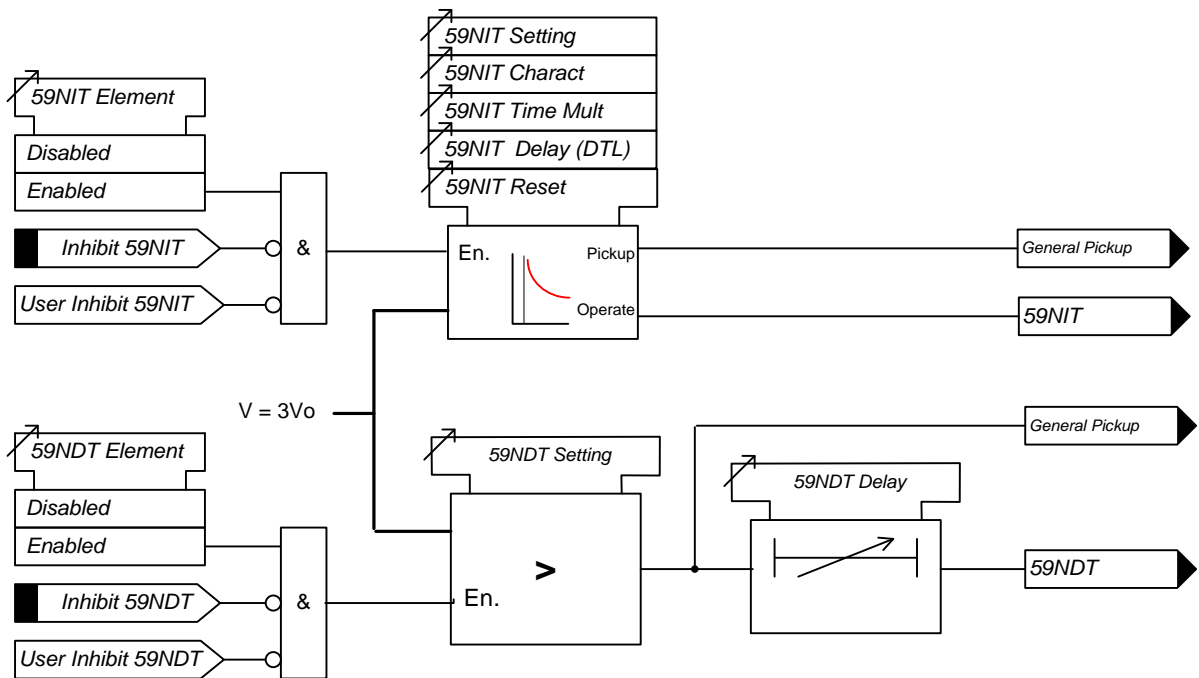

Figure 3-19 Logic Diagram: Neutral Overvoltage Element

3.13 Voltage Protection: Under/Over Frequency (81)

Optionally six under/over frequency elements are provided.

Frequency elements are blocked if the measured voltage falls below the **81 U/V Guard** setting.

The sense of the element (under-frequency or over-frequency) is set by the **81-n Operation** setting.

81-n Setting sets the pick-up frequency for the element.

An output is given after elapse of the **81-n Delay** setting.

The **81-n Hysteresis** setting allows the user to vary the pick-up/drop-off ratio for the element.

Operation of the under/over frequency elements can be inhibited from:

Inhibit 81-n	A binary or virtual input.
81-n U/V Guarded	Under voltage guard element.
User Inhibit	Reylogic (graphical logic).

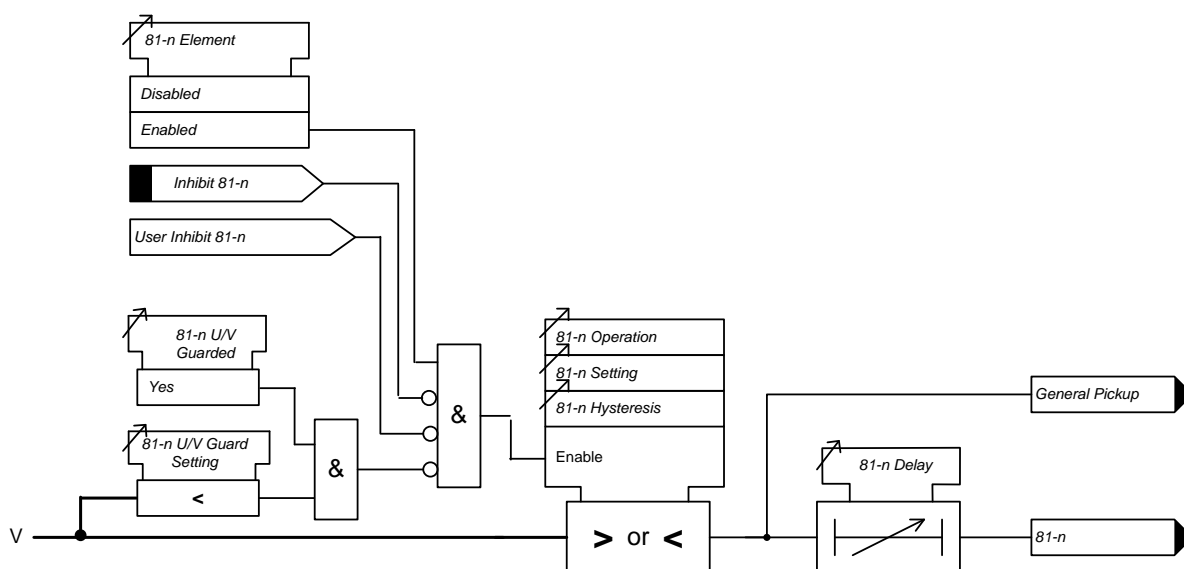

Figure 3-20 Logic Diagram: Under/Over Frequency Detector (81)

Section 4: Control & Logic Functions

4.1 Quick Logic

The 'Quick Logic' feature allows the user to input up to 16 logic equations (E1 to E16) in text format. Equations can be entered using Reydisp or at the relay fascia.

Each logic equation is built up from text representing control characters. Each can be up to 20 characters long. Allowable characters are:

0, 1, 2, 3, 4, 5, 6, 7, 8, 9	Digit
()	Parenthesis
!	'NOT' Function
.	'AND' Function
^	'EXCLUSIVE OR' Function
+	'OR' Function
En	Equation (number)
Fn	Function Key (number)
	'1' = Key pressed, '0' = Key not pressed
In	Binary Input (number)
	'1' = Input energised, '0' = Input de-energised
Ln	LED (number)
	'1' = LED energised, '0' = LED de-energised
On	Binary output (number)
	'1' = Output energised, '0' = Output de-energised
Vn	Virtual Input/Output (number)
	'1' = Virtual I/O energised, '0' = Virtual I/O de-energised

Example Showing Use of Nomenclature

E1=((I1^F1)!.O2)+L1

Equation 1 = ((Binary Input 1 XOR Function Key 1) AND NOT Binary Output 2)

OR

LED 1

When the equation is satisfied (=1) it is routed through a pick-up timer (**En Pickup Delay**), a drop-off timer (**En Dropoff Delay**), and a counter which instantaneously picks up and increments towards its target (**En Counter Target**).

The counter will either maintain its count value **En Counter Reset Mode = OFF**, or reset after a time delay:

En Counter Reset Mode = Single Shot: The **En Counter Reset Time** is started only when the counter is first incremented (i.e. counter value = 1) and not for subsequent counter operations. Where **En Counter Reset Time** elapses and the count value has not reached its target the count value is reset to zero.

En Counter Reset Mode = Multi Shot: The **En Counter Reset Time** is started each time the counter is incremented. Where **En Counter Reset Time** elapses without further count increments the count value is reset to zero.

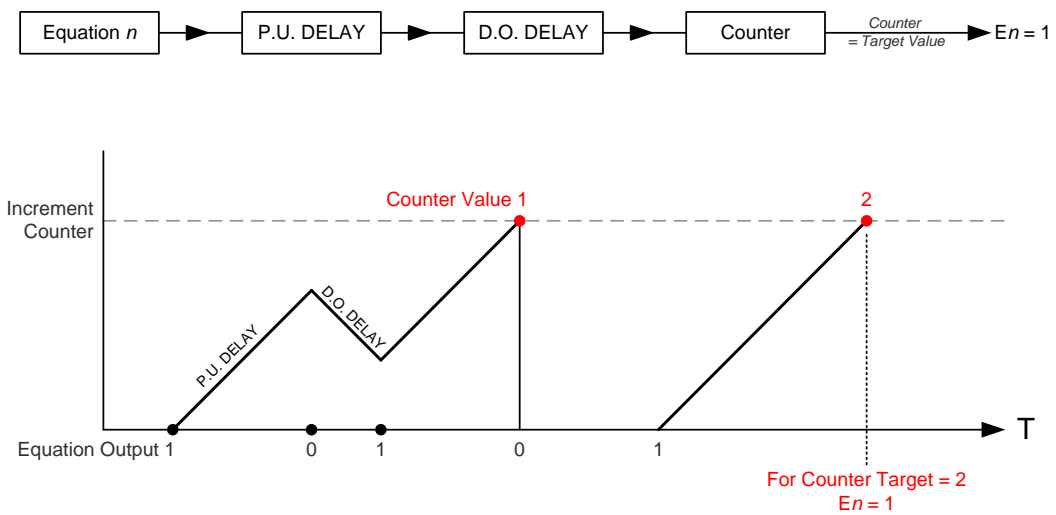

Figure 4-1 Sequence Diagram showing PU/DO Timers in Quick Logic (Counter Reset Mode Off)

When the count value = **En Counter Target** the output of the counter (E_n) = 1 and this value is held until the initiating conditions are removed when E_n is instantaneously reset.

The output of E_n is assigned in the OUTPUT CONFIG>OUTPUT MATRIX menu where it can be programmed to any binary output (O), LED (L) or Virtual Input/Output (V) combination.

Protection functions can be used in Quick Logic by mapping them to a Virtual Input / Output.

Refer to Chapter 7 – Applications Guide for examples of Logic schemes.

Section 5: Supervision Functions

5.1 Circuit Breaker Failure (50BF)

Two CB Fail elements are provided – one element per winding.

Each circuit breaker fail function has two time delayed outputs that can be used for combinations of re-tripping or back-tripping. CB Fail outputs are given after elapse of the **50BF-n-1 Delay** or **50BF-n-2 Delay** settings. The two timers run concurrently.

The circuit breaker fail protection time delays are initiated either from:

- An output **Trip Contact** of the relay (MENU: OUTPUT CONFIG\BINARY OUTPUT CONFIG\CBn Trip Contacts), or

- A binary or virtual input assigned to **50BF-n Ext Trip** (MENU: INPUT CONFIG\INPUT MATRIX\50BF Ext Trip).

- A binary or virtual input assigned to **50BF-n Mech Trip** (MENU: INPUT CONFIG\INPUT MATRIX\ 50BF-n Mech Trip).

CB Fail outputs will be issued providing any of the 3 phase currents are above the **50BF-n Setting** or the current in the fourth CT is above **50BF-n-I4** for longer than the **50BF-n-n Delay** setting, or for a mechanical protection trip the circuit breaker is still closed when the **50BF-n-n Delay** setting has expired – indicating that the fault has not been cleared.

Both **50BF-n-1** and **50BF-n-2** can be mapped to any output contact or LED.

If the **50BF-n CB Faulty** input (MENU: INPUT CONFIG\INPUT MATRIX\CB Faulty) is energised when a CB trip is given the time delays **50BF-n-n Delay** will be by-passed and the output given immediately.

Operation of the CB Fail elements can be inhibited from:

- Inhibit 50BF-n** A binary or virtual input.

- User Inhibit** Reylogic (graphical logic).

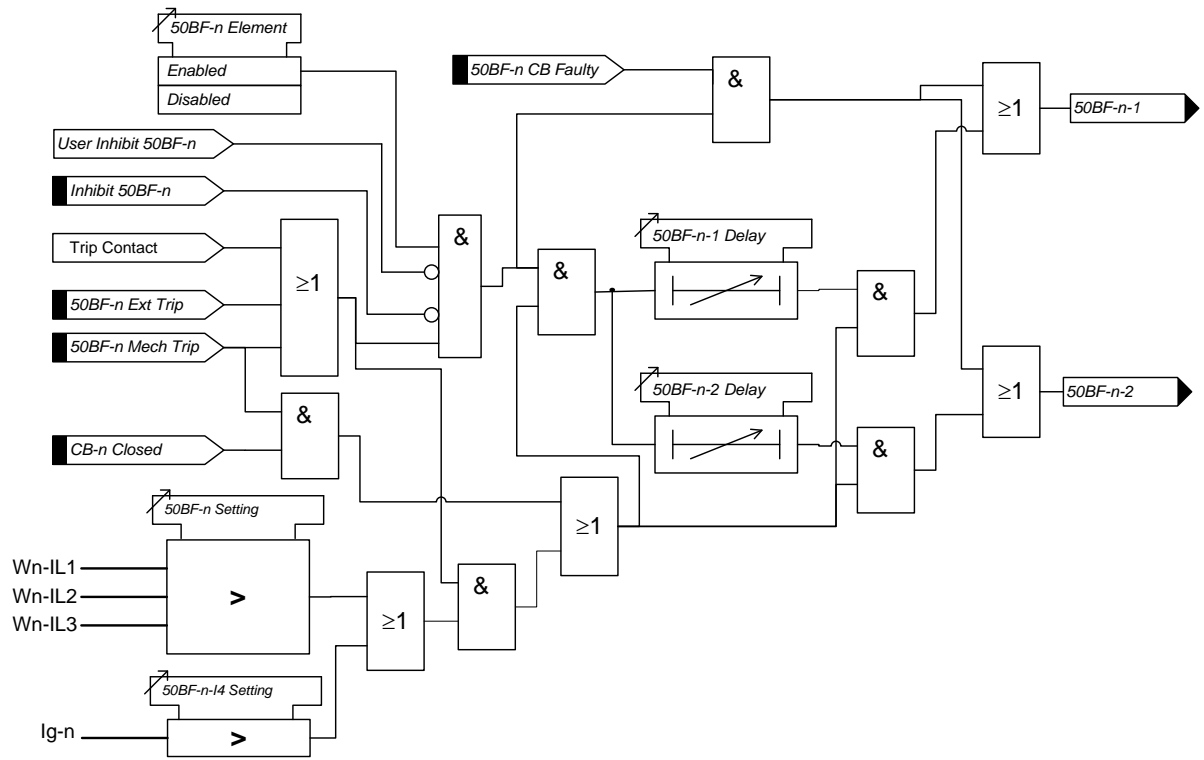

Figure 5-1 Logic Diagram: Circuit Breaker Fail Protection (50BF)

5.2 Trip/Close Circuit Supervision (74TCS/74CCS)

The relay provides six trip and six close circuit supervision elements, all elements are identical in operation and independent from each other allowing 6 trip and 6 close circuits to be monitored.

One or more binary inputs can be mapped to **74TCS-n/74CCS-n**. The inputs are connected into the trip circuit such that at least one input is energised when the trip circuit wiring is intact. If all mapped inputs become de-energised, due to a break in the trip circuit wiring or loss of supply an output is given.

The **74TCS-n Delay** or **74CCS-n Delay** setting prevents failure being incorrectly indicated during circuit breaker operation. This delay should be greater than the operating time of the circuit breaker.

The use of one or two binary inputs mapped to the same Circuit Supervision element (e.g. 74TCS-n) allows the user to realise several alternative monitoring schemes – see ‘Applications Guide’.

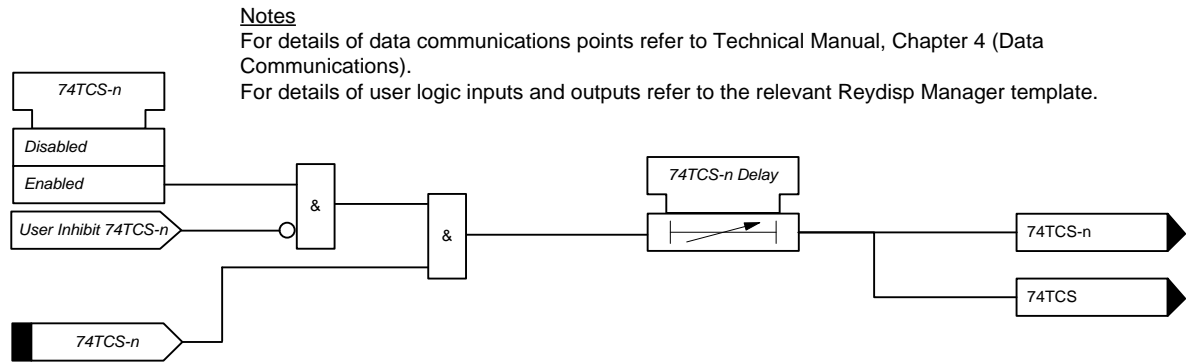

Figure 5-2 Logic Diagram: Trip Circuit Supervision Feature (74TCS)

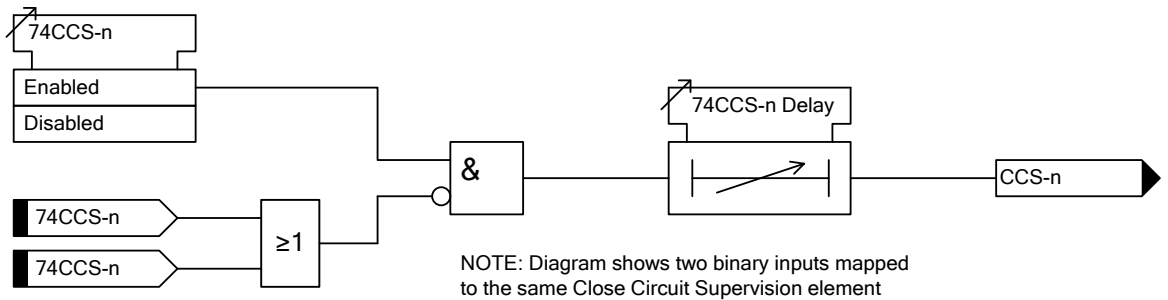

Figure 5-3 Logic Diagram: Close Circuit Supervision Feature (74CCS)

5.3 Inrush Detector (81HBL2)

Inrush detector elements monitor the line currents.

The inrush detector can be used to block the operation of selected elements during transformer magnetising inrush conditions.

The **81HBL2 Bias** setting allows the user to select between **Phase**, **Sum** and **Cross** methods of measurement:

- Phase** Each phase is inhibited separately.
- Sum** With this method the square root of the sum of the squares of the second harmonic in each phase is compared to each operate current individually.
- Cross** All phases are inhibited when any phase detects an inrush condition.

An output is initiated where the measured ratio of second harmonic to fundamental current component content is above the **81HBL2** setting. An LED assigned to this function operates instantaneously, whereas an output relay assigned to this function operates after a 60ms time delay.

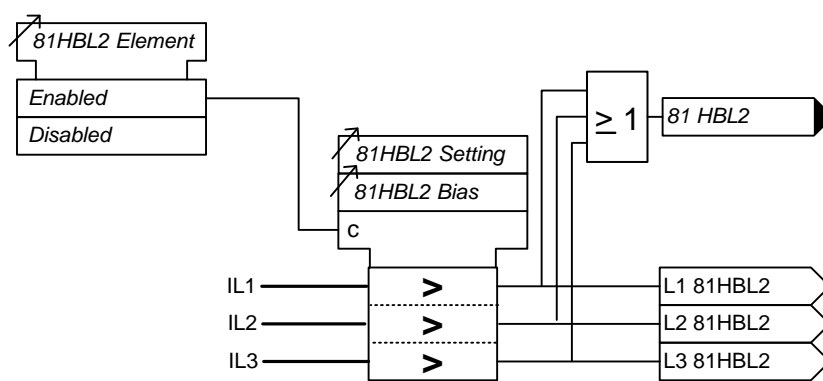

Figure 5-4 Logic Diagram: Inrush Detector Feature (81HBL2)

5.4 Over Fluxing Detector (81HBL5)

Over fluxing detector elements monitor the line currents.

The over fluxing detector can be used to block the operation of differential protection (87BD/ 87HS) elements.

The **81HBL5 Bias** setting allows the user to select between **Phase**, **Sum** and **Cross** methods of measurement:

- Phase** Each phase is inhibited separately
- Sum** The inrush current from each phase is summated and compared to each operate current individually
- Cross** All phases are inhibited when any phase detects an inrush condition

An output is given where the measured fifth harmonic component content is above the **81HBL5** setting.

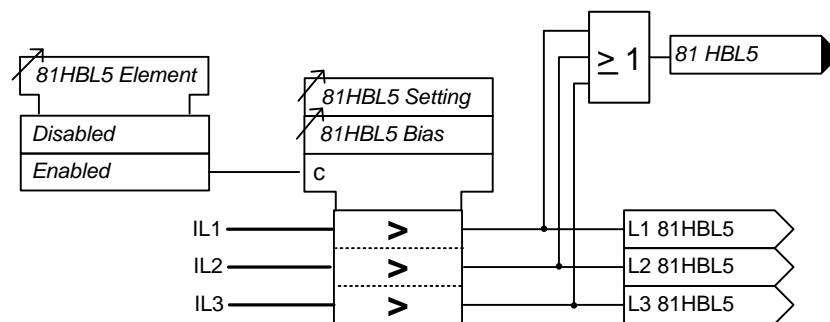

Figure 5-5 Logic Diagram: Overfluxing Detector Feature (81HBL5)

Section 6: Other Features

6.1 Data Communications

Two communication ports, COM1 and COM2 are provided as standard. RS485 connections are available on the terminal blocks at the rear of the relay (COM1). A USB port, COM 2, is provided at the front of the relay for local access using a PC.

Optionally, additional communication ports are available: -

- 2 x fibre optic communication serial ports with ST connectors (COM 3 and COM 4) plus 1 x IRIG B
- 1 RS232 serial port (COM 3) plus IRIG B
- 1 x RS485 serial port (COM 3) plus IRIG B
- 2 x Electrical Ethernet with RJ45 connectors IEC 61850 - (COM 3 and COM 4),
- 2 x Optical Ethernet Duplex LC connectors IEC 61850 - (COM 3 and COM 4).

Communication is compatible with Modbus-RTU, IEC60870-5-103 FT 1.2, DNP 3.0, and IEC60870-5-101 transmission and application standards for all serial ports and IEC 61850 for Ethernet ports.

Reydisp Manager provides the functionality of Reydisp Evolution and also provides project management of multiple devices to allow engineering of IEC61850 projects

Communication with the relay from a personal computer (PC) is facilitated by the REYDISP EVOLUTION software package. The program allows the transfer of relay settings, waveform records, event records, fault data records, Instruments/meters and control functions. REYDISP EVOLUTION is compatible with IEC60870-5-103.

Data communications operation is described in detail in Chapter 4 of this manual.

6.2 IEC 61850 Communications

The relay can optionally be provided with IEC61850 comms.

The 61850 comms can be user configured to provide HSR, PRP and RSTP operation.

For further details refer to the following publications:

IEC 61850 Model Implementation Conformance Statement (MICS)

IEC 61850 PIXIT, PICS, TICS

Protocol Implementation Conformance Statement (PICS), Protocol Implementation Extra Information for Testing (PIXIT) and Technical Issues Implementation Conformance Statement (TICS),

6.3 Maintenance

6.3.1 Output Matrix Test

The feature is available from the Relay fascia and allows the user to operate binary outputs or LEDs assigned to relay functions.

Any protection function which is enabled in the setting menu will appear in the Output Matrix Test.

6.3.2 CB Counters

Four CB trip counters are provided:

CB1 Total Trip Count:	Increments on each trip command issued.
CB1 Delta Trip Count:	Additional counter which can be reset independently of the Total Trip Counter. This can be used, for example, for recording trip operations between visits to a substation.
CB2 Total Trip Count	As CB1
CB2 Delta Trip Count:	As CB1

The status of each counter can be viewed in the INSTRUMENTS mode.

Binary outputs can be mapped to each of the above counters, these outputs are energised when the user defined **Count Target** is reached.

6.3.3 I²t CB Wear

CB1 and CB2 wear counters are also provided:

I ² t CB1 Wear:	Provides an estimate of contact wear and maintenance requirements. The algorithm works on a per phase basis, measuring the arcing current during faults. The I ² t value at the time of trip is added to the previously stored value and an alarm is given when any one of the three phase running counts exceeds the set Alarm limit . The t value is the time between CB contacts separation when an arc is formed, Separation Time , and the CB Clearance time .
I ² t CB2 Wear:	As CB1

The status of each counter can be viewed in the INSTRUMENTS mode.

Binary outputs can be mapped to each of the above counters, these outputs are energised when the user defined **Alarm Limit** is reached.

6.4 Data Storage

6.4.1 General

The relay stores three types of data records: relay event records, analogue/digital waveform records and fault data records. These data records are backed up in non-volatile memory and are permanently stored even in the event of loss of auxiliary d.c. supply voltage.

6.4.2 Event Records

The event recorder feature allows the time tagging of any change of state (Event) in the relay. As an event occurs, the actual event condition is logged as a record along with a time and date stamp to a resolution of 1 millisecond. There is capacity for a maximum of 5000 event records that can be stored in the relay and when the event buffer is full any new record will over-write the oldest. Stored events can be erased using the DATA STORAGE > **Clear Events** setting.

The following events are logged:

- Change of state of Binary outputs.
- Change of state of Binary inputs.
- Change of Settings and Settings Group
- Change of state of any of the control functions of the relay.

All events can be uploaded over the data communications channel(s) and can be displayed in the 'ReyDisp Evolution' package in chronological order, allowing the sequence of events to be viewed. Events are also made available spontaneously to an IEC 60870-5-103 or Modbus RTU compliant control system.

For a complete listing of events available in each model, refer to Technical Manual Chapter 4 'Data Comms'.

6.4.3 Waveform Records.

Waveform records provide a trace of the instantaneous magnitude of each analogue input channel and the status of each binary channel i.e. each binary input, binary output, virtual I/O and LED, against time for the duration of the record. The values are recorded at every digital sampling point used by the relay software.

Each recorded analogue waveform displays an input identifier, minimum value, maximum value and the instantaneous values at both cursor positions (user variable). Each binary waveform displays the input/output number and the initiating condition(s) e.g. external input or protection element.

Triggering of waveform storage is configured from the 'Settings > DATA STORAGE > WAVEFORM STORAGE' menu. Triggering is automatically initiated from operation of any of the selected protection or control elements. Waveform storage can also be triggered from the relay fascia, from a suitably programmed binary input or via the data comms channel(s).

Waveforms are sampled at a rate of 32 samples per cycle.

The latest 100 records are stored, the most recent is waveform 1. Records are archived by the relay during quiescent periods. The duration of each stored record is 1s, 2s, 5s or 10s. The percentage of waveform storage prior to waveform triggering is user configurable. When the waveform archive buffer is full (i.e. 100 records are stored) the triggering of a new waveform record causes the oldest record - waveform 100 - to be overwritten.

Stored waveforms can be deleted from the relay fascia using the DATA STORAGE > *Clear Waveforms* setting or via Reydisp.

6.4.4 Fault Data Records

Measured quantities for the last 100 relay trip fault records are stored with time and date of trip.

The HMI LCD can display the latest 10 fault records with time and date of trip, measured quantities and LED status. The **Max Fault Rec. Time** setting sets the time period from fault trigger during which the operation of any LEDs is recorded.

Records are triggered from operation of an output relay programmed as a 'CBn Trip Contact'. The 'Trip Alert' feature must also be enabled.

To achieve accurate instrumentation values for the fault records when testing, ensure a drop off delay is applied to the test set so that the injected quantities remain on for a short duration, typically 20ms, after the relay has issued the trip output. This extended period of injection simulates the behaviour of the power system where faulted conditions are present until CB operation.

When examined together the event records and the fault records will detail the full sequence of events leading to a trip.

Fault records are stored in a rolling buffer, with the oldest faults overwritten. The fault storage can be cleared with the DATA STORAGE > **Clear Faults** setting.

The SYSTEM CONFIG > **Trip Alert = Disabled** setting allows the above to be switched off e.g. during commissioning tests.

6.4.5 Demand

Maximum, minimum and mean values of line currents and voltage (where applicable) are available as instruments which can be read in the relay INSTRUMENTS MENU or via Reydisp.

The DATA STORAGE > DEMAND DATA LOG > **Data Log Period** setting is used to define the time/duration after which the instrument is updated. The updated value indicates the maximum, minimum and mean values for the defined period.

The **Gn Demand Window** setting defines the maximum period of time over which the demand values are valid. A new set of demand values is established after expiry of the set time.

The **Gn Demand Window Type** can be set to **FIXED, PEAK or ROLLING**.

When set to **FIXED** the maximum, minimum and mean values demand statistics are calculated over fixed Window duration. At the end of each window the internal statistics are reset and a new window is started.

When set to **PEAK** the maximum and minimum values within the **Demand Window** time setting is recorded.

When set to **ROLLING** the maximum, minimum and mean values demand statistics are calculated over a moving Window duration. The internal statistics are updated when the window advances every **Updated Period**.

The statistics can be reset from a binary input or communication command, after a reset the update period and window are immediately restarted.

6.4.6 Demand/Data Log

The Data log feature can be used to build trend and demand records.

Up to 10,080 values for each phase current (W1 and W2) and voltage (where fitted) analogue are recorded. Each recorded value consists of the mean value of the sampled data over the **Data Log Period**.

Stored Data Log records are retrieved using Reydisp.

6.5 Metering

The metering feature provides real-time data available from the relay fascia in the 'Instruments Mode' or via the data communications interface.

For a detailed description refer to Technical Manual Chapter 2 – Settings and Instruments.

6.6 Operating Mode

The relay has three operating modes, Local, Remote and Out of Service. The following table identifies the functions operation in each mode.

The modes can be selected by the following methods:

SYSTEM CONFIG>**RELAY MODE** setting, a Binary Input or Command

OPERATION	REMOTE	LOCAL	OUT OF SERVICE
Control			
Rear Serial Ports (when set as Remote)	Enabled	Disabled	Disabled
Rear Serial Ports (when set as Local)	Disabled	Enabled	Disabled
Fascia (Control Mode)	Disabled	Enabled	Disabled
USB	Disabled	Enabled	Disabled
Binary Inputs	Setting Option	Setting Option	Enabled
Binary Outputs	Enabled	Enabled	Disabled
Reporting			
Spontaneous			
IEC 103	Enabled	Enabled	Disabled
DNP3	Enabled	Enabled	Disabled
General Interrogation			
IEC 103	Enabled	Enabled	Disabled
DNP3	Enabled	Enabled	Disabled
MODBUS	Enabled	Enabled	Enabled
Changing of Settings			
Rear Ports (when set as Remote)	Enabled	Disabled	Enabled
Rear Ports (when set as Local)	Disabled	Enabled	Enabled
Fascia	Enabled	Enabled	Enabled
USB	Disabled	Enabled	Enabled
Historical Information			
Waveform Records	Enabled	Enabled	Enabled
Event Records	Enabled	Enabled	Enabled
Fault Information	Enabled	Enabled	Enabled
Setting Information	Enabled	Enabled	Enabled

Table 6-1 Operating Mode

6.7 Control Mode

This mode provides convenient access to commonly used relay control and test functions. When any of the items listed in the control menu are selected control is initiated by pressing the ENTER key. The user is prompted to confirm the action, again by pressing the ENTER key, before the command is executed.

Control Mode commands are password protected using the Control Password function – see Section 6.10.

6.8 Real Time Clock

Time and date can be set either via the relay fascia using appropriate commands in the System Config menu, via the data comms channel(s) or via the optional IRIG-B input.

In order to maintain synchronism within a substation, the relay can be synchronised to the nearest second or minute using the IEC 60870-5-103 protocol, optional IRIG-B input or binary input.

The default date is set at 01/01/2000, this indicates that no date has been set. When editing the **Time**, only the hours and minutes can be edited. The seconds are zeroed by pressing **ENTER** and the clock begins running.

The time and date are maintained while the relay is de-energised by a back up storage capacitor. The length of time for which this data will be maintained will depend on such things as temperature, length of time in service, etc. However the data will be maintained for a minimum of 1.8 days.

6.8.1 Time Synchronisation – Data Comms

Where the data comms channel(s) is connected to a dedicated substation automation system the relay can be time synchronised using the relevant command within IEC 60870-5-103 or optional DNP3.0 protocols. The time can also be synchronised from 'Reydisp Evolution' which utilises the communications support software.

6.8.2 Time Synchronisation – Binary Input

A binary input can be mapped **Clock Sync from BI**. The seconds or minutes will be rounded up or down to the nearest value when the BI is energised. This input is leading edge triggered.

6.8.3 Time Synchronisation – IRIG-B (Optional)

A BNC connector on the relay rear provides an isolated IRIG-B time synchronisation port. The IRIG-B input is compatible with a modulated 3-6 Volt signal and provides time synchronisation to the nearest millisecond.

6.9 Settings Groups

The relay provides eight groups of settings – Group number (Gn) 1 to 8. At any one time only one group of settings can be 'active' – SYSTEM CONFIG>**Active Group** setting.

It is possible to edit one group while the relay operates in accordance with settings from another 'active' group using the **View/Edit Group** setting.

Some settings are independent of the active group setting i.e. they apply to all settings groups. This is indicated on the top line of the relay LCD – where only the **Active Group No.** is identified. Where settings are group dependent this is indicated on the top line of the LCD by both the **Active Group No.** and the **View Group No.** being displayed.

A change of settings group can be achieved either locally at the relay fascia, remotely over the data comms channel(s) or via a binary input. When using a binary input an alternative settings group is selected only whilst the input is energised (**Select Grp Mode: Level triggered**) or latches into the selected group after energisation of the input (**Select Grp Mode: Edge triggered**).

6.10 Password Feature

The relay incorporates two levels of password protection – one for settings, the other for control functions.

The programmable password feature enables the user to enter a 4 character alpha numeric code to secure access to the relay functions. The relay is supplied with the control password set to **AAAA**. The settings password is supplied set to **NONE**, i.e. the password feature is disabled.

Passwords must be entered twice as a security measure against accidental change. Once a password has been entered then it will be required thereafter to change settings or initiate control commands. Passwords can be de-activated by using the password to gain access and by entering the password **NONE**. Again this must be entered twice to de-activate the security system.

As soon as the user attempts to change a setting or initiate control the password is requested before any changes are allowed. Once the password has been validated, the user is 'logged on' and any further changes can be made without re-entering the password. If no more changes are made within 1 hour then the user will automatically be 'logged off', re-enabling the password feature.

The Settings Password prevents unauthorised changes to settings from the front fascia or over the data comms channel(s). The Control Password prevents unauthorised operation of controls in the relay Control Menu from the front fascia.

The password validation screen also displays a numerical code. If the password is lost or forgotten, this code should be communicated to Siemens Protection Devices Ltd. and the password can be retrieved.

7SR242 Duobias

Multi-Function 2-Winding Transformer Protection Relay

Settings, Configuration & Instruments

Document Release History

This document is issue **2017/12**. The list of revisions up to and including this issue is:

2017/12	Software revision 2662H85001 R8e-7e
2017/08	Software revision 2662H85001 R8c-7d
2013/01	Software revision 2662H85001 R7c-7b
2012/08	Addition of optional IEC 61850 communication protocol and Ethernet Interface.
2010/06	Additional Comms modules option of (RS485 + IRIG-B) and (RS232 + IRIG-B) and typographical revisions
2010/02	Document reformat due to rebrand
2010/02	Software revision 2662H80001 R4c-3
2008/07	Software revision 2662H80001R3d-2c.
2008/05	First issue

The copyright and other intellectual property rights in this document, and in any model or article produced from it (and including any registered or unregistered design rights) are the property of Siemens Protection Devices Limited. No part of this document shall be reproduced or modified or stored in another form, in any data retrieval system, without the permission of Siemens Protection Devices Limited, nor shall any model or article be reproduced from this document unless Siemens Protection Devices Limited consent.

While the information and guidance given in this document is believed to be correct, no liability shall be accepted for any loss or damage caused by any error or omission, whether such error or omission is the result of negligence or any other cause. Any and all such liability is disclaimed.

Contents

Section 1: Introduction	5
1.1 Relay Menus And Display	5
1.2 Operation Guide.....	6
1.2.1 User Interface Operation.....	6
1.3 Settings Display	8
1.4 Instruments Mode	8
1.5 Fault Data Mode	16
Section 2: Setting the Relay Using Reydisp.....	17
2.1 Physical Connection	17
2.1.1 Front USB connection.....	17
2.1.2 Rear RS485 connection.....	18
2.1.3 Optional rear fibre optic connection	18
2.1.4 Optional rear RS485 + IRIG-B connection	19
2.1.5 Optional rear RS232 + IRIG-B connection	19
2.1.6 Optional Rear EN100 Ethernet Module (COM3)	20
2.1.7 Configuring Relay Data Communication	21
2.1.8 Connecting to the Relay via Reydisp	22

APPENDIX 1 7SR242 Settings

List of Figures

Figure 1-1	Menu	5
Figure 1-2	Fascia Contrast symbol	5
Figure 1-3	Fascia of 7SR242 Relay.....	5
Figure 1-4	Relay Identifier Screen	6
Figure 1-5	7SR24 Menu Structure	7
Figure 1-6	Schematic Diagram: Current and Voltage Meters (includes optional functionality)	12
Figure 2-1	USB connection to PC	17
Figure 2-2	RS485 connection to PC	18
Figure 2-3	Fibre Optic Connection to PC	18
Figure 2-4	EN100 Ethernet Module	20
Figure 2-5	PC Comms Port Allocation	22

Section 1: Introduction

1.1 Relay Menus And Display

All relay fascias contain the same access keys although the fascias may differ in appearance from model to model. The basic menu structure is also the same in all products and consists of four main menus, these being,

Settings Mode - allows the user to view and (if allowed via the settings mode password) change settings in the relay.

Instruments Mode - allows the user to view the relay meters e.g. current, voltage etc.

Fault Data Mode - allows the user to see type and data of any fault that the relay has detected.

The menus can be viewed via the LCD by pressing the access keys as below,

Pressing CANCEL returns to the Relay Identifier screen

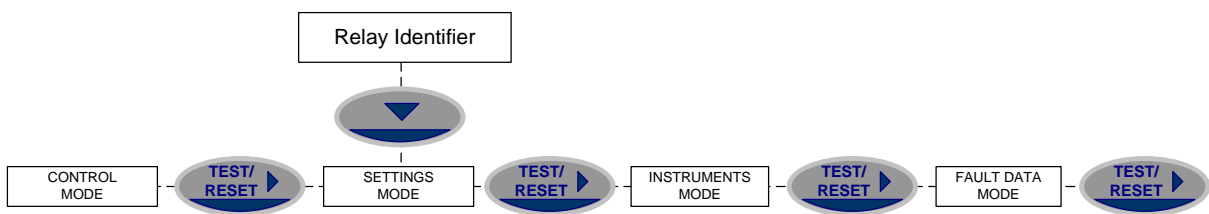

Figure 1-1 Menu

LCD Contrast

To adjust the contrast on the LCD insert a flat nosed screwdriver into the screw below the contrast symbol, turning the screw left or right decreases and increases the contrast of the LCD.



Figure 1-2 Fascia Contrast symbol



Figure 1-3 Fascia of 7SR242 Relay

1.2 Operation Guide

1.2.1 User Interface Operation

The basic menu structure flow diagram is shown in Figure 1.2-2. This diagram shows the main modes of display: Settings Mode, Instrument Mode, Fault Data Mode and Control Mode.

When the relay leaves the factory all data storage areas are cleared and the settings set to default as specified in settings document.

When the relay is first energised the user is presented with the following message: -

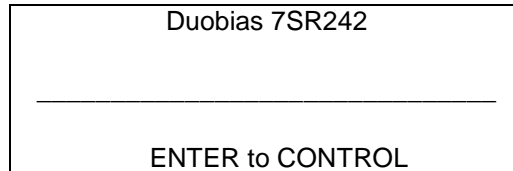

Figure 1-4 Relay Identifier Screen

On the factory default setup the relay LCD should display the relay identifier, on each subsequent power-on the screen that was showing prior to the last power-off will be displayed.

The push-buttons on the fascia are used to display and edit the relay settings via the LCD, to display and activate the control segment of the relay, to display the relays instrumentation and Fault data and to reset the output relays and LED's.

The five push-buttons have the following functions:



READ DOWN



READ UP

These pushbuttons are used to navigate the menu structure and to adjust settings.



ENTER

The ENTER push-button is used to initiate and accept setting changes.

When a setting is displayed pressing the ENTER key will enter the edit mode, the setting will flash and can now be changed using the ▲ or ▼ buttons. When the required value is displayed the ENTER button is pressed again to accept the change.

When an instrument is displayed pressing ENTER will toggle the instruments favourite screen status.



CANCEL

This push-button is used to return the relay display to its initial status or one level up in the menu structure. Pressed repeatedly will return to the Relay Identifier screen. It is also used to reject any alterations to a setting while in the edit mode.



This push-button is used to reset the fault indication on the fascia. When on the Relay Identifier screen it also acts as a lamp test button, when pressed all LEDs will momentarily light up to indicate their correct operation. It is also moves the cursor right ► when navigating through menus and settings.

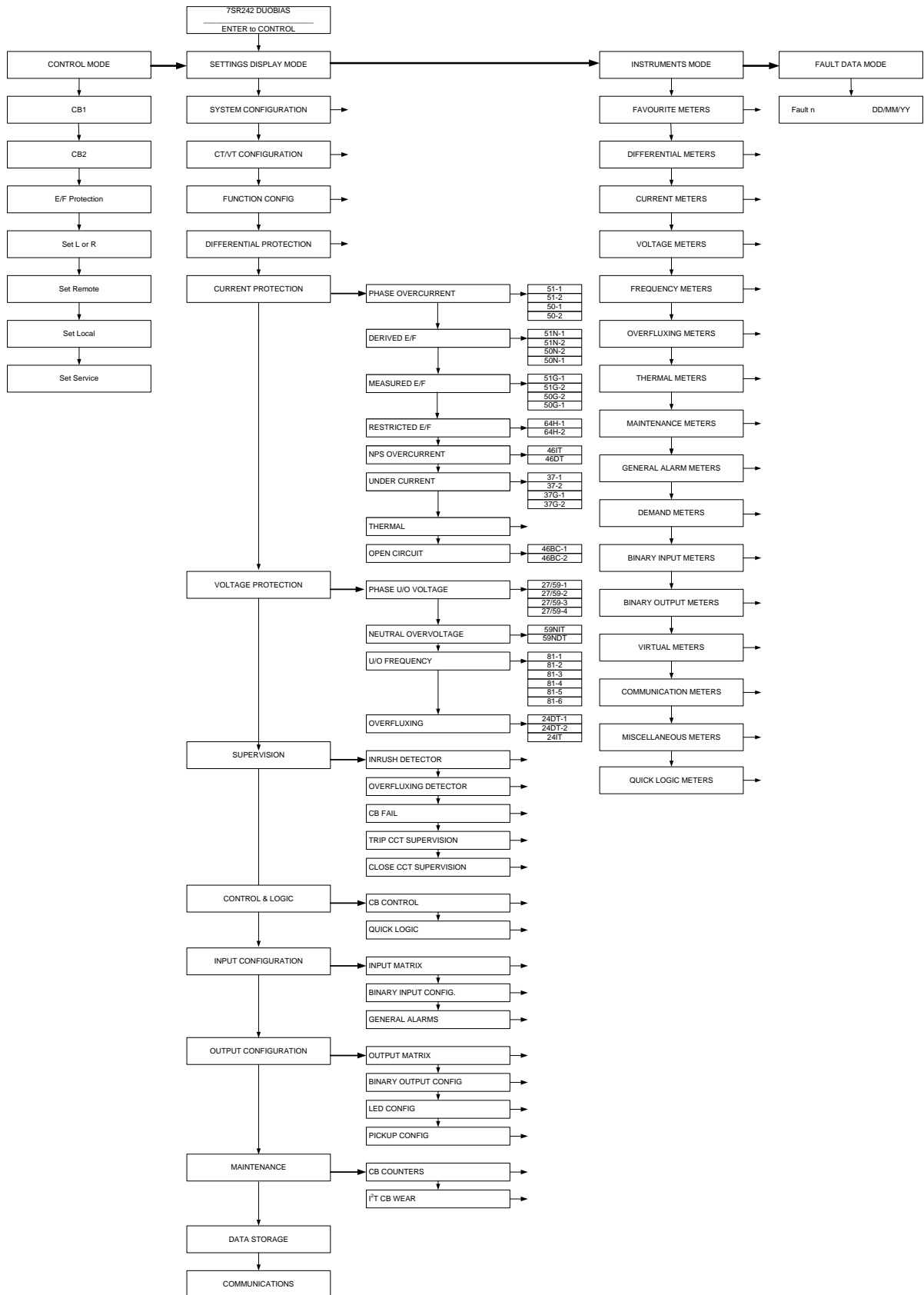

Figure 1-5 7SR24 Menu Structure

1.3 Settings Display

The Settings Mode is reached by pressing the READ DOWN ▼ button from the relay identifier screen.

Once the Settings Mode title screen has been located pressing the READ DOWN ▼ button takes the user into the Settings mode sub-menus.

Each sub-menu contains the programmable settings of the relay in separate logical groups. The sub menus are accessed by pressing the TEST/RESET ► button. Pressing the ▼ button will scroll through the settings, after the last setting in each sub menu is reached the next sub menu will be displayed. If a particular sub menu is not required to be viewed then pressing ▼ will move directly to the next one in the list.

While a setting is being displayed on the screen the ENTER button can be pressed to edit the setting value. If the relay is setting password protected the user will be asked to enter the password. If an incorrect password is entered editing will not be permitted. All screens can be viewed even if the password is not known.

While a setting is being edited flashing characters indicate the edit field. Pressing the ▲ or □▼ buttons will display the valid field values. If these buttons are held on, the rate of scrolling will increase.

Once editing is complete pressing the ENTER button stores the new setting into the non-volatile memory. The setting change is effective immediately unless any protection element is operating, in which case the change becomes effective when no elements are operating.

Configuration and inspection of communications protocol data objects, text used for display in international languages, graphical user logic and programming of user specific custom protection characteristics is not possible from the fascia and pc based tools must be used if required.

The actual setting ranges and default values for each relay model can be found in the appendix to this section of the manual.

1.4 Instruments Mode

The Instrument Mode sub-menu displays key quantities and information to aid with commissioning. The following meters are available and are navigated around by using the ▲, ▼ and TEST/REST buttons.

Instrument	Description
<p>FAVOURITE METERS</p> <p>→to view</p>	<p>This allows the user to view his previously constructed list of 'favourite meters' by pressing TEST/RESET ► button and the READ DOWN button to scroll though the meters added to this sub-group</p> <p>To construct a sub-group of favourite meters, first go to the desired meter then press ENTER this will cause a message to appear on the LCD 'Add To Favourites YES pressing ENTER again will add this to the FAVOURITE METERS Sub-menu. To remove a meter from the FAVOURITE METERS sub-menu go to that meter each in the FAVOURITE METERS sub-menu or at its Primary location press ENTER and the message 'Remove From Favourites' will appear press ENTER again and this meter will be removed from the FAVOURITE METERS sub-group.</p> <p>The relay will poll through, displaying each of the meters selected in favourite meters, after no key presses have been detected for a user settable period of time. The time is set in the Setting menu>System Config>Favourite Meters Timer.</p>

DIFFERENTIAL METERS		→to view	This is the sub-group that includes all the meters that are associated with Current TEST/RESET ► allows access to this sub-group
W1 Line			
Ia	0.00xIn ----°		
Ib	0.00xIn ----°		
Ic	0.00xIn ----°		
W2 Line			Displays Winding 2 Input 3 Phase currents Nominal RMS values & phase angles with respect to PPS voltage.
Ia	0.00xIn ----°		
Ib	0.00xIn ----°		
Ic	0.00xIn ----°		
W1 Relay			Displays Winding 1 relay currents Nominal RMS values & phase angles with respect to PPS voltage.
Ia	0.00xIn ----°		
Ib	0.00xIn ----°		
Ic	0.00xIn ----°		
W2 Relay			Displays Winding 2 relay currents Nominal RMS values & phase angles with respect to PPS voltage.
Ia	0.00xIn ----°		
Ib	0.00xIn ----°		
Ic	0.00xIn ----°		
Operate			Displays the 3 phase operate currents' relevant to the biased differential (87BD) and highset differential (87HS) functions.
Ia	0.00xIn		
Ib	0.00xIn		
Ic	0.00xIn		
Restrain			Displays the 3 phase restrain currents relevant to the biased differential (87BD) function.
Ia	0.00xIn		
Ib	0.00xIn		
Ic	0.00xIn		
W1 1st Harmonic			Displays W1 3 phase fundamental current components Nominal RMS values.
Ia	0.00xIn		
Ib	0.00xIn		
Ic	0.00xIn		
W1 2 nd Harmonic			Displays W1 3 phase 2 nd Harmonic current components Nominal RMS values.
Ia	0.00xIn		
Ib	0.00xIn		
Ic	0.00xIn		
W1 5 nd Harmonic			Displays W1 3 phase 5th Harmonic current components Nominal RMS values.
Ia	0.00xIn		
Ib	0.00xIn		
Ic	0.00xIn		
W2 1st Harmonic			See above.
W2 2 nd Harmonic			See above.
W2 5th Harmonic			See above.

CURRENT METERS →to view	This is the sub-group that includes all the meters that are associated with Current TEST/RESET ► allows access to this sub-group
W1 Primary Ia 0.00kA Ib 0.00kA Ic 0.00kA	Displays the 3 phase currents Primary RMS values
W1 Secondary Ia 0.00A Ib 0.00A Ic 0.00A	Displays the 3 phase currents Secondary RMS values
W1 Nominal Ia 0.00xIn ----° Ib 0.00xIn ----° Ic 0.00xIn ----°	Displays the 3 Phase currents Nominal RMS values & phase angles with respect to PPS voltage.
W1 Sequence Izps 0.00xIn ----° Ipps 0.00xIn ----° Inps 0.00xIn ----°	Displays the 3 Phase currents Nominal RMS values & phase angles with respect to PPS voltage.
W1 Derived Earth (In) Ia kA Ib A Ic xIn	Displays the Earth currents derived from W1 line currents. RMS values.
W2 Primary	See above.
W2 Secondary	See above.
W2 Nominal	See above.
W2 Sequence	See above.
W2 Derived Earth (In)	See above.
Measured Earth – 1 (Ig) Ig 0.000kA Ig 0.000A Ig 0.000xIn	Displays the Earth currents for IG1. RMS values
Measured Earth – 2 (Ig) Ig 0.000kA Ig 0.000A Ig 0.000xIn	Displays the Earth currents for IG2. RMS values

VOLTAGE METERS →to view	This is the sub-group that includes all the meters that are associated with Voltage TEST/RESET ► allows access to this sub-group
Voltage Meters Pri (Ph-Ph) 0.00kV Sec 0.00V Nom 0.00xVn	Displays the Voltage RMS values

FREQUENCY METERS →to view	This is the sub-group that includes all the meters that are associated with Frequency TEST/RESET ► allows access to this sub-group
Frequency 00.000Hz	Displays the power system frequency.

OVERFLUXING METERS →to view	This is the sub-group that includes all the meters that are associated with Over-fluxing. TEST/RESET ► allows access to this sub-group
Overfluxing Meters V/f V xVn V/f xVn/fn V/f 24IT %	Displays the over-fluxing values

THERMAL METERS →to view	This is the sub-group that includes all the meters that are associated with Thermal TEST/RESET ► allows access to this sub-group
Thermal Status Phase A 0.0% Phase B 0.0% Phase C 0.0%	Displays the thermal capacity

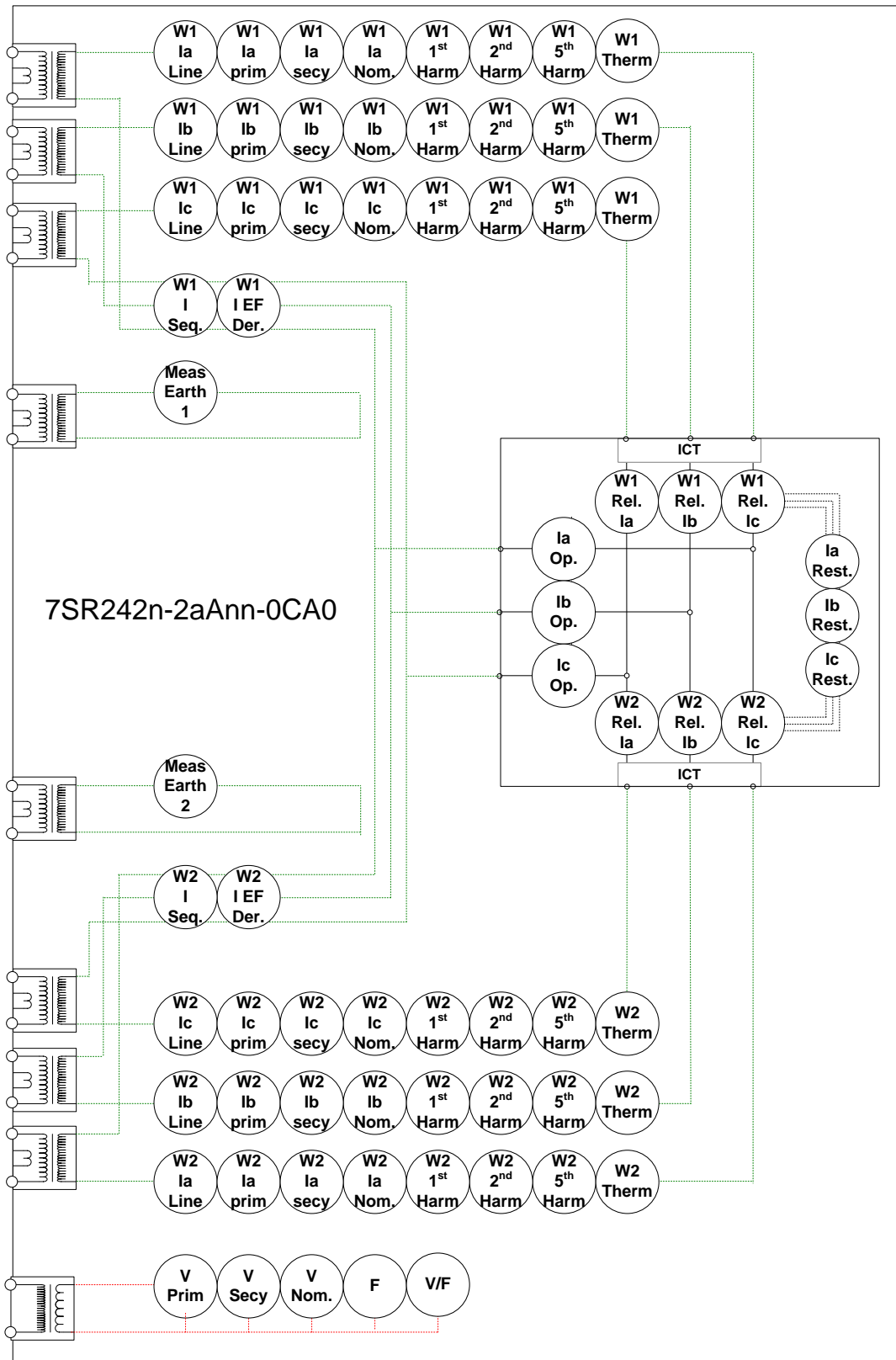

Figure 1-6 Schematic Diagram: Current and Voltage Meters (includes optional functionality)

MAINTENANCE METERS →to view		This is the sub-group that includes all the meters that are associated with Maintenance TEST/RESET ► allows access to this sub-group
CB1 Manual Close Last Close CB1 Manual Open Last Open	ms ms	Displays the CB manual opening and closing times
CB2 Manual Close Last Close CB2 Manual Open Last Open	ms ms	Displays the CB opening and closing times
CB1 Total Trips Count Target	0 100	Displays the number of CB trips experienced by the CB
CB1 Delta Trips Count Target	0 100	Displays the number of CB trips experienced by the CB
CB2 Total Trips Count Target	0 100	Displays the number of CB trips experienced by the CB
CB2 Delta Trips Count Target	0 100	Displays the number of CB trips experienced by the CB
CB1 Wear Phase A Phase B Phase C	0.00MA ² s 0.00MA ² s 0.00MA ² s	Displays the current measure of circuit breaker wear.
CB2 Wear Phase A Phase B Phase C	0.00MA ² s 0.00MA ² s 0.00MA ² s	Displays the current measure of circuit breaker wear.
CB1 Trip Time Trip Time CB2 Trip Time Trip Time	ms ms ms	Displays the CB manual opening and closing times

GENERAL ALARM METERS →to view	This is the sub-group that includes all the meters that are associated with the Binary inputs TEST/RESET ► allows access to this sub-group
General Alarms ALARM 1 Cleared	Displays the state of General Alarm
General Alarms ALARM 2 Cleared	
General Alarms ALARM 3 Cleared	
General Alarms ALARM 4 Cleared	
General Alarms ALARM 5 Cleared	
General Alarms ALARM 6 Cleared	
General Alarms ALARM 7 Cleared	
General Alarms ALARM 8 Cleared	
General Alarms ALARM 9 Cleared	
General Alarms ALARM 10 Cleared	
General Alarms ALARM 11 Cleared	
General Alarms ALARM 12 Cleared	

DEMAND METERS →to view	This is the sub-group that includes Demand meters. Values are available for user defined time periods. TEST/RESET ► allows access to this sub-group
Voltage Demand	Displays maximum, minimum and mean values
W1 I Phase A Demand	
W1 I Phase B Demand	
W1 I Phase C Demand	
W2 I Phase A Demand	
W2 I Phase B Demand	
W2 I Phase C Demand	
Frequency Demand	

BINARY INPUT METERS →to view	This is the sub-group that includes all the meters that are associated with the Binary inputs TEST/RESET ► allows access to this sub-group
BI 1-8 ---- ---- BI 9-13 ---- -	Displays the state of DC binary inputs 1 to 8 (The number of binary inputs may vary depending on model)

BINARY OUTPUT METERS →to view	This is the sub-group that includes all the meters that are associated with the Binary Outputs TEST/RESET ► allows access to this sub-group
BO 1-8 ---- ---- BO 9-14 ---- --	Displays the state of DC binary Outputs 1 to 8. (The number of binary outputs may vary depending on model)

VIRTUAL METERS →to view	This is the sub-group that shows the state of the virtual status inputs in the relay TEST/RESET ► allows access to this sub-group
V 1-8 ---- ---- V 9-16 ---- ----	Displays the state of Virtual Outputs 1 to 16 (The number of virtual inputs will vary depending on model)

COMMUNICATION METERS →to view	This is the sub-group that includes all the meters that are associated with Communications ports TEST/RESET ► allows access to this sub-group
COM1 COM2 COM3 COM4	Displays which com ports are currently active
COM1 TRAFFIC Tx1 0 Rx1 0 Rx1 Errors 0	Displays traffic on Com1
COM2 TRAFFIC Tx2 0 Rx2 0 Rx2 Errors 0	Displays traffic on Com2
COM3 TRAFFIC Tx3 0 Rx3 0 Rx3 Errors 0	Displays traffic on Com3
COM4 TRAFFIC Tx4 0 Rx4 0 Rx4 Errors 0	Displays traffic on Com4

MISCELLANEOUS METERS →to view	This is the sub-group that includes indication such as the relays time and date, the amount of fault and waveform records stored in the relay TEST/RESET ► allows access to this sub-group
Date DD/MM/YYYY Time HH:MM:SS Waveform Recs 0 Fault Recs 0	This meter displays the date and time and the number of Fault records and Event records stored in the relay. The records stored in the relay can be cleared using the options in the Settings Menu>Data Storage function.
Event Recs 0 Data Log Recs 0	

QUICK LOGIC METERS	
→to view	
E 1-8 E 9-16	
E1 Equation 0 EQN = 0 TMR 0-0 = 0 CNT 0-1 = 0	
En Equation	

1.5 Fault Data Mode

The Fault Data Mode sub menu lists the time and date of the previous ten protection operations. The stored data about each fault can be viewed by pressing the TEST/RESET ► button. Each record contains data on the operated elements, analogue values and LED flag states at the time of the fault. The data is viewed by scrolling down using the ▼ button.

Section 2: Setting the Relay Using Reydisp

Reydisp Evolution software provides a pc tool which can be used for programming of protection configuration and settings and the mapping of hardware input and outputs using a graphical interface. It is supplied with additional tools for configuration of serial communication protocol data objects, configuration of text for international language support and programming of user specific time current curves. To configure the relay using a serial communication port the user will need the following:-

PC with Reydisp Evolution Installed. (This can be download from our website www.siemens.com/energy and found under the submenu 'Software').

Configuration and download of IEC 61850 data and programming of graphical user logic requires the use of the Reydisp Manager software which is supplied with online instructions and help and is not documented here.

2.1 Physical Connection

The relay can be connected to Reydisp via any of the communication ports on the relay. Suitable communication Interface cable and converters are required depending which port is being used.

2.1.1 Front USB connection

To connect your pc locally via the front USB port.

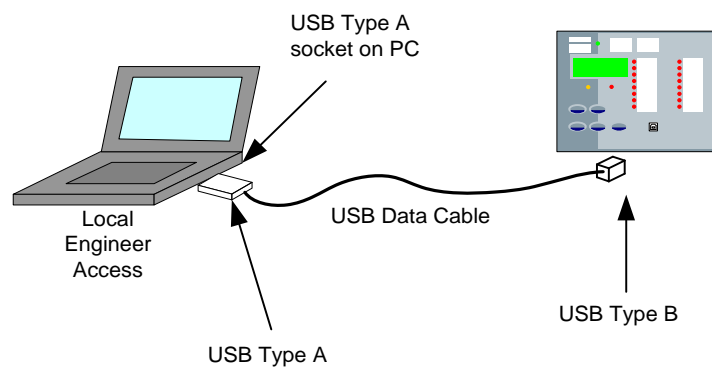

Figure 2-1 USB connection to PC

2.1.2 Rear RS485 connection

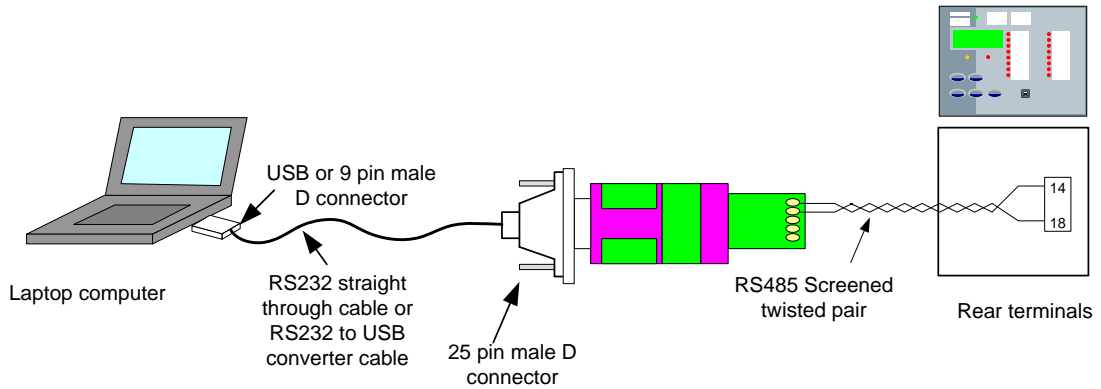

Figure 2-2 RS485 connection to PC

2.1.3 Optional rear fibre optic connection

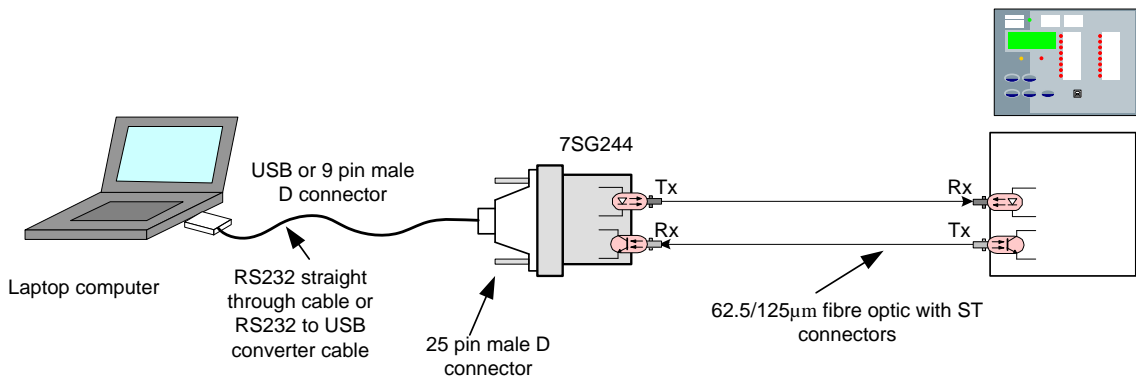

Figure 2-3 Fibre Optic Connection to PC

Sigma devices have a 25 pin female D connector with the following pin out.

Pin	Function
2	Transmit Data
3	Received Data
4	Request to Send
5	Clear to Send
6	Data set ready
7	Signal Ground
8	Received Line Signal Detector
20	Data Terminal Ready

2.1.4 Optional rear RS485 + IRIg-B connection

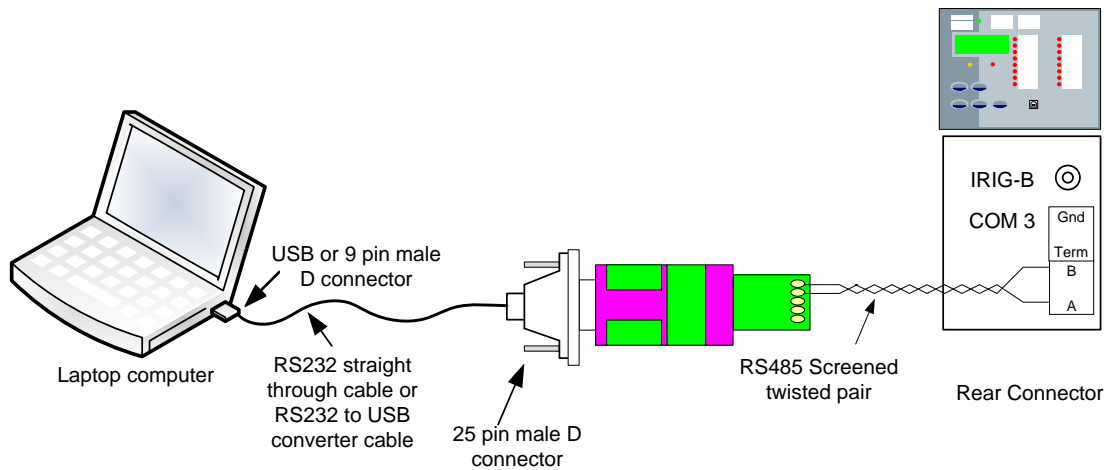

Figure 2.1-1 Additional (Optional) rear RS485 + IRIg-B connection to a PC

2.1.5 Optional rear RS232 + IRIg-B connection

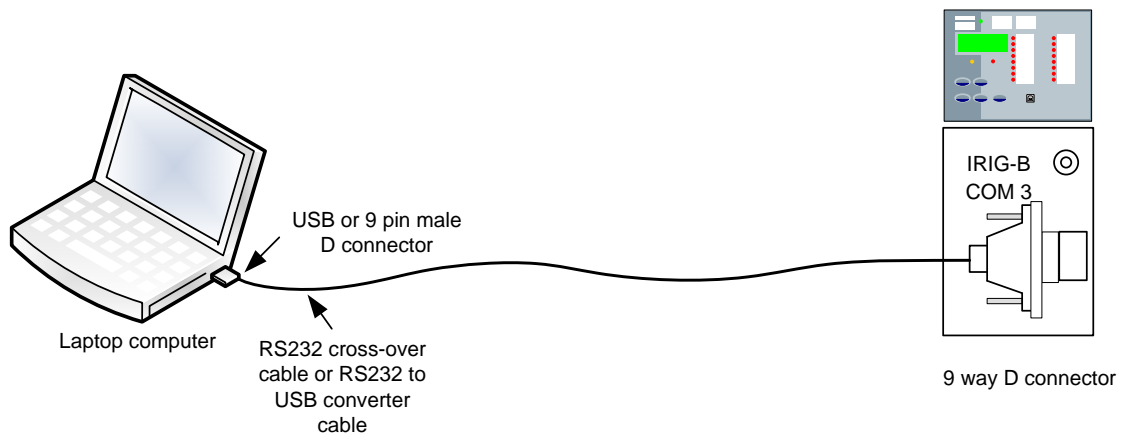

Figure 2.1-2 Additional (Optional) rear RS232 + IRIg-B connection to a PC

Pin	Relay Function
1	Not Connected
2	Receive Data (RXD)
3	Transmit Data (TXD)
4	Output Supply +5 V 50mA
5	Signal Ground (GND)
6	Input Supply +5 V 50mA
7	Linked to 8 (volts free)
8	Linked to 7 (volts free)
9	Output Supply +5V 50mA

2.1.6 Optional Rear EN100 Ethernet Module (COM3)

The optional ethernet interface is primarily provided for support of IEC 61850 protocol. Support for IEC 870-5-103 is also provided over this interface to allow connection with Reydisp Evolution and Reydisp Manager software for interrogation, editing and download of relay settings and other data. Ordering options are available with two RJ45 electrical connectors or with two duplex LC fibre optic connectors.

Setting name	Range	Default	Setting	Notes
LAN Protocol	OFF, IEC60870-5-103	IEC60870-5-103		

If this setting is set to Off, access to relay data using Reydisp Evolution and Reydisp Manager software via the Ethernet interface is not available.

Connections to the optional EN100 ethernet module are made on the rear underside of the relay.

Connections are made to either RJ45 sockets (electrical) or Duplex LC (fibre optic) connectors.

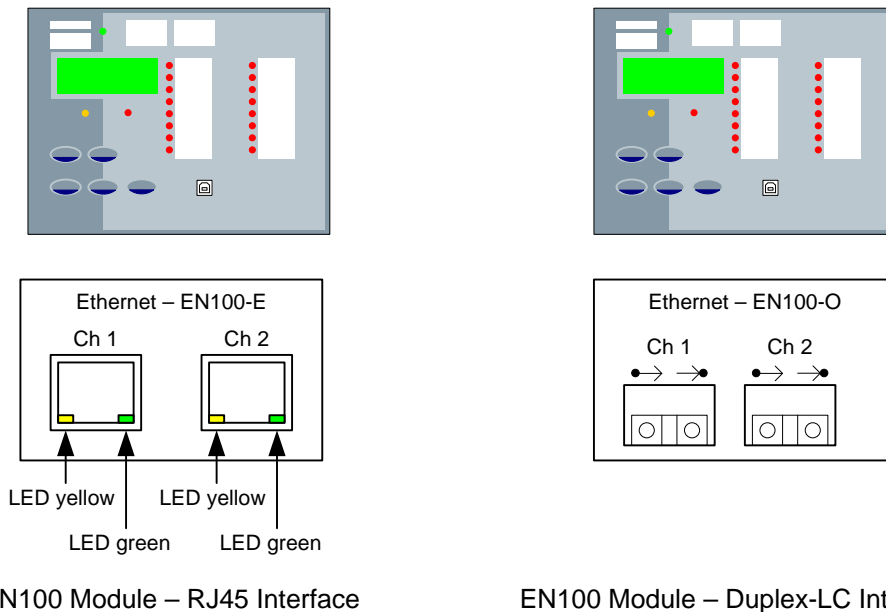

EN100 Module – RJ45 Interface

EN100 Module – Duplex-LC Interface

Green LED (Physical Link)

Off – No link

On – Link present

Yellow LED (Activity)

Off – No traffic

On/flashing - Traffic

Figure 2-4 EN100 Ethernet Module

2.1.7 Configuring Relay Data Communication

Using the keys on the relay fascia scroll down the settings menu's into the 'communications' menu. All of the below settings may not be available in all relay types. Reydisp software is compatible with IEC60870-5-103 protocol.

COM1-RS485 Port

COM2-USB Port (Front)

COM3 – Optional Fibre Optic, RS485, RS232 or Ethernet Port

COM4 – Optional Fibre Optic Port

LAN – Optional Ethernet Ports

Setting name	Range	Default	Units	Notes
Station Address	0 ... 65534	0		Address given to relay to identify that relay from others which may be using the same path for communication as other relays for example in a fibre optic hub
COM1-RS485 Protocol	OFF, IEC60870-5-103, MODBUS-RTU, DNP3	IEC60870-5-103		COM1: Rear mounted RS485 port
COM1-RS485 Mode	Local,Remote, Local or Remote	Remote		
COM1-RS485 Baud Rate	75 110 150 300 600 1200 2400 4800 9600 19200 38400	19200		
COM1-RS485 Parity	NONE, ODD, EVEN	EVEN		
COM2-USB Protocol	OFF, IEC60870-5-103, MODBUS-RTU, ASCII, DNP3	IEC60870-5-103		COM2: Front USB port.
COM2-USB Mode	Local,Remote, Local or Remote	Remote		
COM3 Protocol	OFF, IEC60870-5-103, MODBUS-RTU, DNP3	IEC6-0870-5-103		COM3: Optional rear mounted connection
COM3 Baud Rate	75 110 150 300 600 1200 2400 4800 9600 19200 38400 57600 115200	19200		
COM3 Parity	NONE, ODD, EVEN	EVEN		
COM3 Line Idle*	LIGHT ON, LIGHT OFF	LIGHT OFF		
COM3 Data echo*	ON, OFF	OFF		
COM4 Protocol**	OFF, IEC60870-5-103, MODBUS-RTU, DNP3	OFF		COM4: Optional rear mounted Fibre Optic ST connection
COM4 Baud Rate**	75 110 150 300 600 1200 2400 4800 9600 19200 38400	19200		
COM4 Parity**	NONE, ODD, EVEN	EVEN		
COM4 Line Idle**	LIGHT ON, LIGHT OFF	LIGHT OFF		
COM4 Data echo**	ON, OFF	OFF		
DNP3 Unsolicited Events	ENABLED, DISABLED	DISABLED		Setting is only visible when a port protocol is set to DNP3.

Setting name	Range	Default	Units	Notes
DNP3 Destination Address	0 ... 65534	0		Setting is only visible when a port protocol is set to DNP3.
DNP3 Application Timeout	5, 6 ... 299, 300	10s	Seconds	Setting is only visible when a port Protocol is set to DNP3

*Not applicable for RS485 or RS232 interface modules.

**Fibre Optic Module only

2.1.8 Connecting to the Relay via Reysdisp

When Reysdisp software is running all available communication ports of the PC will automatically be detected. On the start page tool bar open up the sub-menu File > Connect.

The 'Communication Manager' window will display all available communication ports. With the preferred port highlighted, select the 'Properties' option and ensure the baud rate and parity match that selected in the relay Data Comms settings. Select 'Connect' to initiate the relay-PC connection.

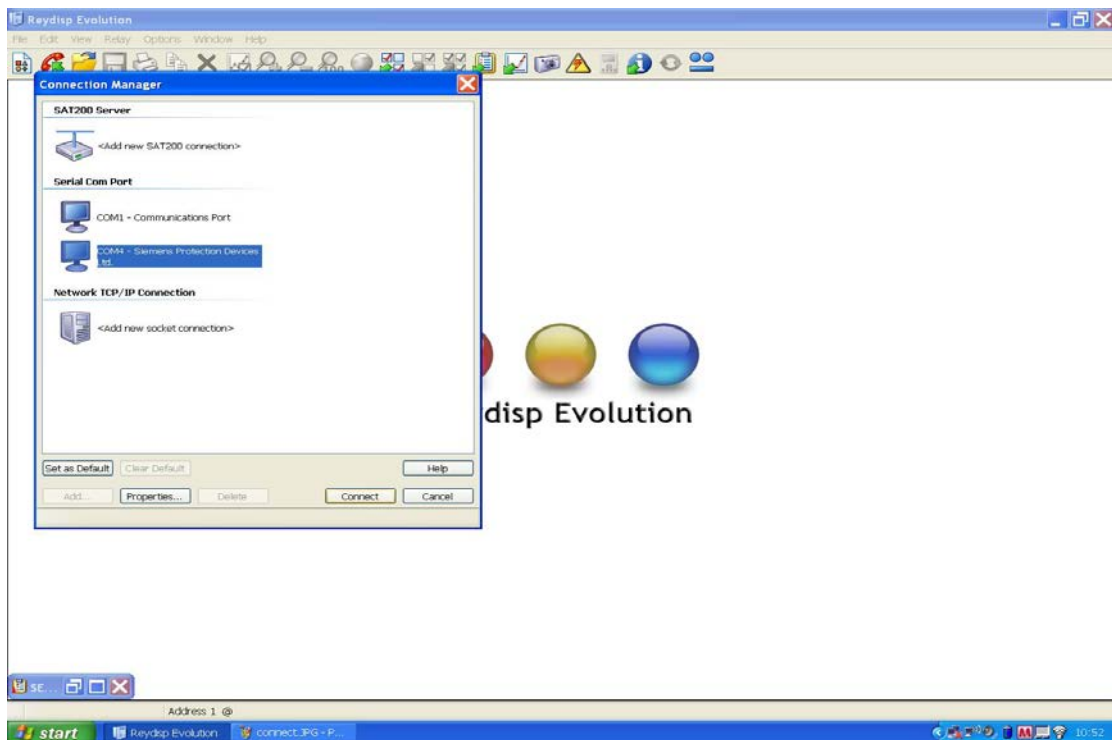

Figure 2-5 PC Comms Port Allocation

Via the Relay > Set Address > Address set the relay address (1-254) or alternatively search for connected devices using the Relay > Set Address > Device Map. The relay can now be configured using the Reysdisp software. Please refer to the Reysdisp Evolution Manual for further guidance.

7SR242 Duobias

Multi-Function 2-Winding Transformer Protection Relay

Performance Specification

Document Release History

This document is issue 2019/08. The list of revisions up to and including this issue is:

2019/08	Power supply options updated.
2017/12	Software revision 2662H85001 R8e-7e. Universal PSU variants added.
2017/08	Software revision 2662H85001 R8c-7d
2015/11	7SR2424 data added – section 1.1.3 Time multiplier settings revised – sections 2.5, 2.10, 2.11 and 2.12.
2014/04	Revision to sections 1.2.11 and 2.16.2
2013/01	Software revision 2662H85001 R7c-7b
2012/08	Minor corrections and addition of optional IEC 61850 communication protocol.
2012/02	Clarification made to differential protection operate times, sections 2.16.3 and 2.17.3
2010/06	Additional Comms modules option of (RS485 + IRIG-B) and (RS232 + IRIG-B) and typographical revisions
2010/02	Document reformat due to rebrand
2010/02	Third issue. Software revision 2662H80001 R4c-3
2008/07	Second issue. Software revision 2662H80001R3d-2c.
2008/05	First issue

The copyright and other intellectual property rights in this document, and in any model or article produced from it (and including any registered or unregistered design rights) are the property of Siemens Protection Devices Limited. No part of this document shall be reproduced or modified or stored in another form, in any data retrieval system, without the permission of Siemens Protection Devices Limited, nor shall any model or article be reproduced from this document unless Siemens Protection Devices Limited consent.

While the information and guidance given in this document is believed to be correct, no liability shall be accepted for any loss or damage caused by any error or omission, whether such error or omission is the result of negligence or any other cause. Any and all such liability is disclaimed.

Contents

Section 1: Common Functions.....	7
1.1 General.....	7
1.1.1 CE Conformity.....	7
1.1.2 Reference.....	7
1.1.3 Dimensions and Weights.....	7
1.2 Energising Quantities.....	8
1.2.1 Auxiliary Power Supply.....	8
1.2.2 AC Current.....	10
1.2.3 AC Voltage.....	11
1.2.4 Binary (Digital) Outputs.....	12
1.2.5 Binary (Digital) Inputs.....	12
1.3 Functional Performance.....	14
1.3.1 Instrumentation.....	14
1.3.2 Data Communication.....	14
1.3.3 Real Time Clock.....	15
1.4 Environmental Performance.....	16
1.4.1 General.....	16
1.4.2 Emissions.....	17
1.4.3 Immunity.....	17
1.4.4 Mechanical.....	19
Section 2: Protection Functions.....	20
2.1 24 Over Fluxing.....	20
2.1.1 Reference (24DT).....	20
2.1.2 Operate and Reset Level (24DT).....	20
2.1.3 Operate and Reset Time (24DT).....	20
2.1.4 Reference (24IT).....	20
2.1.5 Operate and Reset Level (24IT).....	20
2.1.6 Operate and Reset Time (24IT).....	21
2.2 27/59 Under/Over Voltage.....	22
2.2.1 Reference.....	22
2.2.2 Operate and Reset Level.....	22
2.2.3 Operate and Reset Time.....	22
2.3 37,37G Undercurrent.....	23
2.3.1 Reference.....	23
2.3.2 Operate and Reset Level.....	23
2.3.3 Operate and Reset Time.....	23
2.4 46BC Open Circuit.....	24
2.4.1 Reference.....	24
2.4.2 Operate and Reset Level.....	24
2.4.3 Operate and Reset Time.....	24
2.5 46NPS Negative Phase Sequence Overcurrent.....	25
2.5.1 Reference (46DT).....	25
2.5.2 Operate and Reset Level (46DT).....	25
2.5.3 Operate and Reset Time (46DT).....	25
2.5.4 Reference (46IT).....	25
2.5.5 Operate and Reset Level (46IT).....	25
2.5.6 Operate and Reset Time (46IT).....	26
2.6 49 Thermal Overload.....	27
2.6.1 Reference.....	27
2.6.2 Operate and Reset Level.....	27
2.6.3 Operate and Reset Time.....	27
2.7 50 instantaneous overcurrent.....	29
2.7.1 Reference.....	29
2.7.2 Operate and Reset Level.....	29
2.7.3 Operate and Reset Time.....	29
2.8 50N instantaneous Derived Earth Fault.....	30
2.8.1 Reference.....	30
2.8.2 Operate and Reset Level.....	30
2.8.3 Operate and Reset Time.....	30
2.9 50G Instantaneous Measured Earth Fault.....	31

2.9.1	Reference	31
2.9.2	Operate and Reset Level	31
2.9.3	Operate and Reset Time	31
2.10	51 Time Delayed Overcurrent	32
2.10.1	Reference	32
2.10.2	Operate and Reset Level	32
2.10.3	Operate and Reset Time	33
2.11	51N Time Delayed Derived Earth Fault	34
2.11.1	Reference	34
2.11.2	Operate and Reset Level	34
2.11.3	Operate and Reset Time	35
2.12	51G Time Delayed Measured Earth Fault	36
2.12.1	Reference	36
2.12.2	Operate and Reset Level	36
2.12.3	Operate and Reset Time	37
2.13	59N Neutral Voltage Displacement	41
2.13.1	Reference (59NDT)	41
2.13.2	Operate and Reset Level (59NDT)	41
2.13.3	Operate and Reset Time (59NDT)	41
2.13.4	Reference (59NIT)	41
2.13.5	Operate and Reset Level (59NIT)	41
2.13.6	Operate and Reset Time (59NIT)	42
2.14	64H Restricted Earth Fault Protection	43
2.14.1	Reference	43
2.14.2	Operate and Reset Level	43
2.14.3	Operate and Reset Time	43
2.14.4	Harmonic Rejection	43
2.15	81Under/Over Frequency	44
2.15.1	Reference	44
2.15.2	Operate and Reset Level	44
2.15.3	Operate and Reset Time	44
2.16	87 Biased Differential	45
2.16.1	Reference	45
2.16.2	Operate and Reset Level	46
2.16.3	Operate Time	46
2.17	87HS High-Set Differential	47
2.17.1	Reference	47
2.17.2	Operate and Reset Level	47
2.17.3	Operate and Reset Time	47
Section 3: Supervision Functions		48
3.1	50BF Circuit Breaker Fail	48
3.1.1	Reference	48
3.1.2	Operate and Reset Level	48
3.1.3	Operate and Reset Time	48
3.2	74TCS/CCS Trip/Close Circuit Supervision	49
3.2.1	Reference	49
3.2.2	Operate and Reset Time	49
3.3	81HBL2 Inrush Detector	50
3.3.1	Reference	50
3.3.2	Operate and Reset Level	50
3.3.3	Operate and Reset Time	50
3.4	81HBL5 Overfluxing Detector	51
3.4.1	Reference	51
3.4.2	Operate and Reset Level	51
3.4.3	Operate and Reset Time	51

List of Figures

Figure 1-1: Binary Input Configurations Providing Compliance with EATS 48-4 Classes ESI 1 and ESI 2.....	13
Figure 2-1 Thermal Overload Protection Curves	28
Figure 2-2 IEC IDMTL Curves (Time Multiplier=1).....	38
Figure 2-3 ANSI IDMTL Operate Curves (Time Multiplier=1)	39
Figure 2-4 ANSI Reset Curves (Time Multiplier=1).....	40

Section 1: Common Functions

1.1 General

1.1.1 CE Conformity

 This product is CE compliant to relevant EU directives.

1.1.2 Reference

1.1.2.1 Accuracy Reference Conditions

This product has been tested under the following conditions, unless specifically stated otherwise.

Parameter	Value
Auxiliary supply	Nominal
AC Voltage	Nominal
AC Current	Nominal
Frequency	Nominal
Ambient temperature	20 °C

1.1.3 Dimensions and Weights

1.1.3.1 Dimensions

Parameter	Value	
Width	7SR2422, E8 case	208 mm
	7SR2423, E10 case	260 mm
	7SR2424, E12 case	312 mm
Height	177 mm	
Depth behind panel (including clearance for wiring and fibre)	241.5 mm	
Projection (from front of panel)	31 mm	

See appropriate case outline and panel drilling drawing, as specified in Diagrams and Parameters document, for complete dimensional specifications.

1.1.3.2 Weights

Parameter	Value	
Net weight	7SR2422, E8 case	5.2 kg
	7SR2423, E10 case	6.8 kg
	7SR2424, E12 case	8.4 kg

Additional weights to the above (typical):-

Optional fibre optic, RS485 or RS232 communication interface: add 0.165 kg.

Optional EN100 Ethernet communication interface: add 0.5 kg.

1.2 Energising Quantities

1.2.1 Auxiliary Power Supply

Nominal Operating Range		Absolute Range*	MLFB Code (column 9)
V_{AUX}	24 to 250 VDC 100 to 230 VAC 50/60Hz	19.2 to 275 VDC 80 – 253VAC	M, N

*No relay operation outside of this range is permissible or implied.

Burden

Battery/supply loading can be estimated from the following approximate figures:

Burden (24 V DC to 250 V DC, 100 V AC to 230 V AC) PSU

Attribute	Watts (DC)						
	24	48	60	110	125	220	250
Voltage							
Quiescent Relay (inc. 'PROT HEALTHY' LED)	6.0	5.8	5.8	5.4	5.4	5.2	5.2
Backlight	1.4	1.3	1.2	1.2	1.2	1.2	1.2
Per LED – (Red or Green)	0.04	0.03	0.03	0.03	0.03	0.03	0.03
Per LED – Yellow	0.08	0.06	0.06	0.06	0.06	0.06	0.06
Per Binary Output	0.35	0.3	0.3	0.3	0.3	0.28	0.28
Optional IEC 61850 Comms Interface	2.6	2.5	2.4	2.4	2.4	2.4	2.4

Attribute	VA (RMS AC)					
	100	110	115	120	200	230
Voltage						
Quiescent Relay (inc. 'PROT HEALTHY' LED)	13.4	13.7	13.7	14.0	16.0	17.0
Backlight	2.5	2.5	2.5	2.6	3.0	3.2
Per LED – (Red or Green)	0.06	0.06	0.06	0.06	0.06	0.07
Per LED – Yellow	0.10	0.12	0.10	0.10	0.10	0.12
Per Binary Output	0.6	0.6	0.6	0.6	0.6	0.6
Optional IEC 61850 Comms Interface	5	5	5	5	4.5	4.5

Burden (30V DC, 48V DC, 110V DC, 220V DC)PSU

Attribute		Watts			
		30V	48V	110V	220V
Quiescent Relay (inc. 'PROT HEALTHY' LED)		6.0	5.7	5.0	4.9
Backlight		1.3	1.3	1.3	1.3
LED - Red or Green)	Each LED	0.04	0.04	0.04	0.04
LED – Yellow	Each LED	0.08	0.08	0.08	0.08
Binary Output	Each Output	0.25	0.25	0.25	0.25
Optional F.O. / RS485 / RS232 Data Comms Interface		1.0	1.0	1.0	1.0
Optional IEC 61850 Comms Interface		2.0	2.0	2.0	2.0

DC Supply Variation

IEC 60255-11,

Quantity	Value
Allowable superimposed ac component	≤ 12% of DC voltage
Allowable breaks/dips in supply (collapse to zero from nominal voltage)	≤ 50ms

1.2.2 AC Current

Nominal		Measuring Range
I_n	1, 5 A Phase and earth	$80 \times I_n$
f_n	50, 60Hz	47 to 62Hz

Note. 1 A and 5 A nominal inputs are user selectable on each model.

1.2.2.1 Burden

Attribute	Value - Phase and Earth	
	1A	5A
AC Burden	$\leq 0.1 \text{ VA}$	$\leq 0.3 \text{ VA}$

1.2.2.2 Thermal Withstand

Overload Period	Current	
	Phase and Earth	
	1A	5A
Continuous	$3.0 \times I_n$	
10 minutes	$3.5 \times I_n$	
5 minutes	$4.0 \times I_n$	
3 minutes	$5.0 \times I_n$	
2 minutes	$6.0 \times I_n$	
3 seconds	57.7A	202A
2 seconds	70.7A	247A
1 second	100A	350A
1 cycle	700A	2500A

1.2.3 AC Voltage

Nominal		Operating Range
V_n	40 to 160 V	Up to 270 V
f_n	50, 60Hz	47 to 62Hz

1.2.3.1 Burden

Attribute	Value
AC Burden	≤ 0.1 VA at 110 V

1.2.3.2 Thermal Withstand

Overload Period	Voltage
Continuous	300 V RMS

1.2.4 Binary (Digital) Outputs

Contact rating to IEC 60255-0-2

Attribute		Value
Carry continuously		5A AC or DC
Make and carry (L/R ≤ 40 ms and V ≤ 300 V)	for 0.5 s	20A AC or DC
	for 0.2 s	30A AC or DC
Break (≤ 5 A and ≤ 300 V)	AC resistive	1250 VA
	AC inductive	250 VA at p.f. ≤ 0.4
	DC resistive	75 W
	DC inductive	30 W at L/R ≤ 40ms 50 W at L/R ≤ 10ms
Contact Operate / Release Time		6ms / 3ms
Minimum number of operations		1000 at maximum load
Minimum recommended load		0.5 W at minimum of 10mA or 5V

1.2.5 Binary (Digital) Inputs

	Type (maximum threshold)	Nominal Voltage	Minimum threshold	Maximum withstand
V_{BI}	19 VDC	24, 48, 60 110, 220 V DC	17 VDC	320 VDC
	88 VDC	110, 220 V DC	74 VDC	

1.2.5.1 Performance

Attribute		Value
Maximum DC current for operation	$V_{BI} = 19 \text{ V}$	1.5mA
	$V_{BI} = 88 \text{ V}$	1.5mA
Reset/Operate voltage ratio		≥ 90 %
Response time		< 7ms
Response time when programmed to energise an output relay contact (i.e. includes output relay operation)		< 20ms

The binary inputs are opto couplers having a low minimum operate current and may be set for high speed operation. Where a binary input is both used to influence a control function (e.g. provide a tripping function) and it is considered to be susceptible to mal-operation due to capacitive currents, the external circuitry can be modified to provide immunity to such disturbances.

To comply with EATS 48-4, classes ESI 1 and ESI 2, external components / BI pick-up delays are required as shown in fig. 1-1.

To achieve immunity from AC interference, a BI pick-up delay of typically one-cycle can be applied.

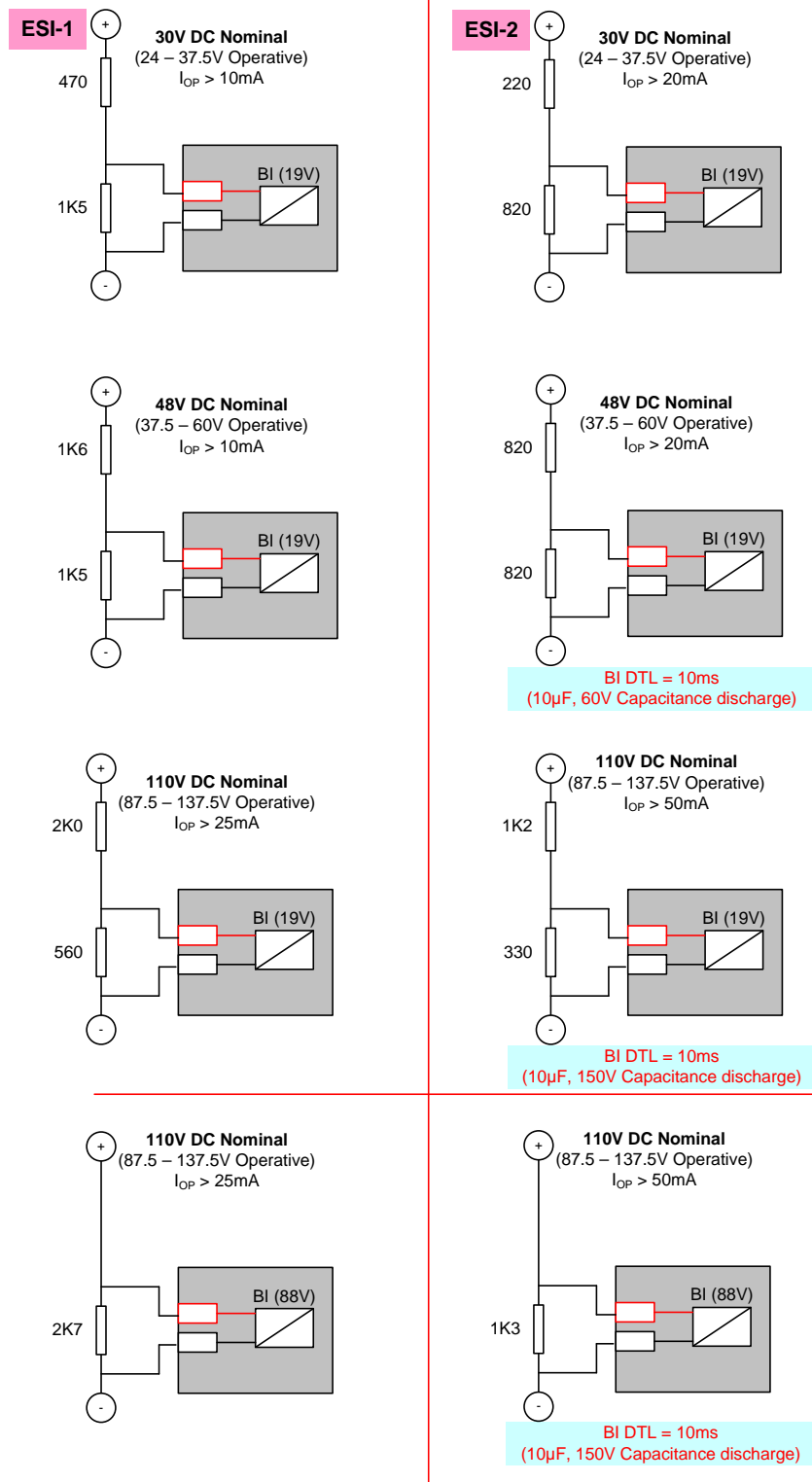

Resistor power ratings: 30V DC Nominal >3W
 48V DC Nominal >3W
 110V DC Nominal >10W (ESI- 1)
 110V DC Nominal >20W (ESI-2)

Resistors must be wired with crimped connections as they may run hot

Figure 1-1: Binary Input Configurations Providing Compliance with EATS 48-4 Classes ESI 1 and ESI 2

1.3 Functional Performance

1.3.1 Instrumentation

	Instrument Value	Reference	Typical accuracy
<i>I</i>	Current	0.1In to 2.0In	$\pm 1\%$ or $\pm 1\% In$
<i>V</i>	Voltage	0.1Vn to 1.2Vn	$\pm 1\%$ or $\pm 1\% Vn$

1.3.2 Data Communication

1.3.2.1 USB Data Communication Interface

Attribute	Value
Physical layer	Electrical
Connectors	USB-Type B

1.3.2.2 Fibre optic Data Communication Interface (Optional Rear Mounted Port COM3 / COM4)

Attribute	Value
Physical layer	Fibre-optic
Connectors	ST™ (BFOC/2.5)
Recommended fibre	62.5/125 μ m glass fibre with ST connector
Optical wavelength	820nm
Launch power (into recommended fibre)	-16 dBm
Receiver sensitivity	-24 dBm

1.3.2.3 RS485 Data Communication Interface (Standard Rear Port)

Attribute	Value
Physical layer	Electrical
Connectors	4mm Ring Crimp

1.3.2.4 RS485 Data Communication Interface (Optional Rear Mounted Port COM3)

Attribute	Value
Physical layer	Electrical
Connectors	4-way Plug

1.3.2.5 RS232 Data Communication Interface (Optional Rear Mounted Port COM3)

Attribute	Value
Physical layer	Electrical
Connectors	9-way D-plug

1.3.2.6 Fibre Optic Ethernet Data Communication Interface (IEC 61850 Option)

Attribute	Value
Physical Layer	Fibre Optic
Connectors	Duplex LC 100BaseF in acc. With IEEE802.3
Recommended Fibre	62.5/125 μ m glass fibre with Duplex-LC connector
Transmission Speed	100MBit/s
Optical Wavelength	1300nm
Bridgeable distance	2km

1.3.2.7 Electrical Ethernet Data Communication Interface (IEC 61850 Option)

Attribute	Value
Physical Layer	Electrical
Connectors	RJ45 100BaseF in acc. With IEEE802.3
Transmission Speed	100MBit/s
Test Voltage (with regard to socket)	500 VAC 50 Hz
Bridgeable distance	20m

1.3.3 Real Time Clock

1.3.3.1 Internal Clock

The specification below applies only while no external synchronisation signal (e.g. IRIG-B, IEC 60870-5-103) is being received.

Attribute	Value
Accuracy (-40 to +85°C)	\pm 3.5 ppm (No auxiliary supply connected)
	\pm 100 ppm (Auxiliary supply connected)

1.3.3.2 IRIG-B

Attribute	Value
Connector	BNC
Signal Type	IRIG-B 120, 122 or 123
Applied signal level	minimum 3 V, maximum 6 V, peak-to-peak
Signal : carrier ratio	\geq 3
Input Impedance	4k Ohms Approx.

1.4 Environmental Performance

1.4.1 General

1.4.1.1 Temperature

IEC 60068-2-1/2

Type	Level
Operating range	-10 °C to +55 °C
Storage range	-25 °C to +70 °C

1.4.1.2 Humidity

IEC 60068-2-78

Type	Level
Operational test	56 days at 40 °C and 93 % relative humidity

1.4.1.3 Transient Overvoltage

IEC 60255-5

Type	Level
Between all terminals and earth, or between any two independent circuits	5.0 kV, 1.2/50 μ s 0.5j

1.4.1.4 Insulation

IEC 60255-5

Type	Level
Between any terminal and earth	2.0 kV AC RMS for 1 min
Between independent circuits	
Across normally open contacts	1.0 kV AC RMS for 1 min

1.4.1.5 Enclosure Protection

IEC 60529

Type	Level
Installed with cover on	IP 51 from front
Installed with cover removed	IP 20 from front

1.4.2 Emissions

IEC 60255-25

1.4.2.1 Radiated Radio Frequency

Type	Limits at 10 m, Quasi-peak
30 to 230 MHz	40 dB(μ V/m)
230 to 10000 MHz	47 dB(μ V/m)

1.4.2.2 Conducted Radio Frequency

Type	Limits	
	Quasi-peak	Average
0.15 to 0.5 MHz	79 dB(μ V)	66 dB(μ V)
0.5 to 30 MHz	73 dB(μ V)	60 dB(μ V)

1.4.3 Immunity

1.4.3.1 Auxiliary DC Supply Variation

Quantity	Value
Allowable superimposed ac component	\leq 12% of DC voltage
Allowable breaks/dips in supply (collapse to zero from nominal voltage)	\leq 20ms

1.4.3.2 High Frequency Disturbance

IEC 60255-22-1

Type	Level	Variation
Case, Aux Power & I/O common (longitudinal) mode	2.5 kV	\leq 10 %
Case, Aux Power & I/O Series (transverse) mode	1.0 kV	
RS485 Metallic Comms	1.0kV	No data loss

1.4.3.3 Electrostatic Discharge

IEC 60255-22-2 Class IV

Type	Level	Variation
Contact discharge	8.0 kV	\leq 5 %

1.4.3.4 Radiated Immunity

IEC 60255-22-3 Class III

Type	Level	Variation
80 MHz to 1000 MHz	10 V/m	\leq 5 %

1.4.3.5 Electrical Fast Transient / Burst Immunity

IEC 60255-22-4 Class A (2002)

Type	Level	Variation
Case, Aux Power & I/O	4.0 kV	≤ 10 %
RS485 Metallic Comms	2.0 kV	No data loss

1.4.3.6 Surge Immunity

IEC 60255-22-5, IEC 61000-4-5

Type	Level	Variation
Analog Inputs Line to Earth	4.0 kV	≤ 10 %
Case, Aux Power & I/O Line to Earth	2.0 kV	
Analog Inputs Line to Line	1.0 kV	
Case, Aux Power & I/O Line to Line	1.0 kV*	
RS485 Comms port Line to Earth	1.0 kV	No data loss

* Note 45ms pick up delay applied to binary inputs

1.4.3.7 Conducted Radio Frequency Interference

IEC 60255-22-6

Type	Level	Variation
0.15 to 80 MHz	10 V	≤ 5 %

1.4.3.8 Magnetic Field with Power Frequency

IEC 6100-4-8 Level 5

100A/m, (0.126mT) continuous	50Hz
1000A/m, (1.26mT) for 3s	

1.4.4 Mechanical

1.4.4.1 Vibration (Sinusoidal)

IEC 60255-21-1 Class I

Type	Level	Variation
Vibration response	0.5 gn	≤ 5 %
Vibration endurance	1.0 gn	

1.4.4.2 Shock and Bump

IEC 60255-21-2 Class I

Type	Level	Variation
Shock response	5 gn, 11 ms	≤ 5 %
Shock withstand	15 gn, 11 ms	
Bump test	10 gn, 16 ms	

1.4.4.3 Seismic

IEC 60255-21-3 Class I

Type	Level	Variation
Seismic response	1 gn	≤ 5 %

1.4.4.4 Mechanical Classification

Type	Level
Durability	> 10 ⁶ operations

Section 2: Protection Functions

2.1 24 Over Fluxing

2.1.1 Reference (24DT)

	Parameter	Value
V/f_s	Setting	0.10, 0.11... 2.0 x Nominal Voltage / Nominal Frequency
$Hyst$	Hysteresis setting	0, 0.1... 80.0%
t_d	Delay setting	0.00, 0.01...20.00, 20.50... 100, 101... 1000, 1010... 10000, 10100... 14400 s

2.1.2 Operate and Reset Level (24DT)

	Attribute	Value
V/f_{op}	Operate level	100% x V/f_s , $\pm 2\%$ or ± 0.02
	Reset level	$\geq 95\%$ of V/f_{op}
	Repeatability	$\pm 1\%$
	Variation	-10 °C to +55 °C $\leq 5\%$

2.1.3 Operate and Reset Time (24DT)

	Attribute	Value
t_{basic}	Element basic operate time	0.9 to 1.1 x V/f_s : 400 ms ± 200 ms
		0.9 to 2.0 x V/f_s : 320 ms ± 200 ms
t_{op}	Operate time following delay	$t_{basic} + t_d$, $\pm 1\%$ or ± 200 ms
	Repeatability	$\pm 1\%$
	Disengaging time	< 250ms

2.1.4 Reference (24IT)

	Parameter	Value
t_{reset}	Reset setting	0, 1... 1000 s

2.1.5 Operate and Reset Level (24IT)

	Attribute	Value
V/f_{op}	Operate level	100% x V/f_s , $\pm 2\%$ or ± 0.02
	Reset level	$\geq 95\%$ of V/f_{op}
	Repeatability	$\pm 1\%$
	Variation	-10 °C to +55 °C $\leq 5\%$

2.1.6 Operate and Reset Time (24IT)

	Attribute	Value
t_{basic}	Element basic operate time	500ms \pm 300ms
t_{op}	Operate time following delay	$t_{basic} + t_d, \pm 1 \% \text{ or } \pm 2s$
	Repeatability	$\pm 1 \%$
	Disengaging time	< 250ms

2.2 27/59 Under/Over Voltage

2.2.1 Reference

	Parameter	Value
V_s	Setting	5, 5.5...200V
$hyst$	Hysteresis setting	0, 0.1... 80.0%
t_d	Delay setting	0.00, 0.01...20.00, 20.50... 100, 101... 1000, 1010... 10000, 10100... 14400 s

2.2.2 Operate and Reset Level

	Attribute	Value
V_{op}	Operate level	100 % V_s , ± 1 % or $\pm 0.25V$
	Reset level	Overvoltage $= (100 \% - hyst) \times V_{op}, \pm 1 \%$
		Undervoltage $= (100 \% + hyst) \times V_{op}, \pm 1 \%$
	Repeatability	± 1 %
	Variation	-10 °C to +55 °C ≤ 5 %
		$f_{nom} - 3$ Hz to $f_{nom} + 2$ Hz ≤ 5 %

2.2.3 Operate and Reset Time

	Attribute	Value
t_{basicE}	Element basic operate time	Overvoltage 0 to 1.1 x V_s : 73 ms \pm 10ms
		0 to 2.0 x V_s : 63 ms \pm 10ms
		Undervoltage 1.1 to 0.5 x V_s : 58 ms \pm 10ms
t_{op}	Operate time following delay	$t_{basic} + t_d, \pm 1$ % or ± 10 ms
	Repeatability	± 1 % or ± 10 ms
	Disengaging time	< 80 ms

2.3 37,37G Undercurrent

2.3.1 Reference

	Parameter	Value
I_s	37-n Setting	0.05, 0.10...5.0 $\times I_n$
t_d	37-n Delay setting	0.00, 0.01...20.00, 20.50... 100, 101... 1000, 1010... 10000, 10100... 14400 s
I_s	37-n U/I Guard Setting	0.05, 0.10...5.0 $\times I_n$

	Parameter	Value
I_s	37G-n Setting	0.05, 0.10...5.0 $\times I_n$
t_d	37G-n Delay setting	0.00, 0.01...20.00, 20.50... 100, 101... 1000, 1010... 10000, 10100... 14400 s

2.3.2 Operate and Reset Level

	Attribute	Value
I_{op}	Operate level	100 % I_s , $\pm 5\%$ or $\pm 1\% I_n$
	Reset level	$\leq 105\% I_{op}$
	Repeatability	$\pm 1\%$
	Variation	-10 °C to +55 °C
		$f_{nom} - 3\text{ Hz}$ to $f_{nom} + 2\text{ Hz}$
		$\leq 5\%$
		$\leq 5\%$

2.3.3 Operate and Reset Time

	Attribute	Value
t_{basic}	Element basic operate time	1.1 to 0.5 $\times I_s$: 35 ms, $\pm 10\text{ms}$
t_{op}	Operate time following delay	$t_{basic} + t_d$, $\pm 1\%$ or $\pm 10\text{ms}$
	Repeatability	$\pm 1\%$ or $\pm 10\text{ms}$
	Overshoot time	$< 40\text{ ms}$
	Disengaging time	$< 60\text{ ms}$

2.4 46BC Open Circuit

2.4.1 Reference

	Parameter	Value
I_{set}	NPS to PPS ratio	20,21...100%
t_f	Delay setting	0.03,04,20.0,20.1,100,101,1000,1010.....14400 s
I_s	46BC-n U/I Guard Setting	0.05, 0.10...5.0 xIn

2.4.2 Operate and Reset Level

	Attribute	Value
I_{curr}	Operate level: NPS to PPS ratio	100 % $I_{set} \pm 5\%$
	Reset level	90 % $I_{curr}, \pm 5\%$
	Repeatability	$\pm 1\%$
	Variation	-10 °C to +55 °C
		$f_{nom} - 3\text{ Hz to } f_{nom} + 2\text{ Hz}$
		harmonics to f_{cutoff}
		$\leq 5\%$
		$\leq 5\%$

	Attribute	Value
I_{op}	Operate level: 46BC-n U/I Guard Setting	100 % $I_s, \pm 5\%$ or $\pm 1\% I_n$
	Reset level	$\leq 105\% I_{op}$
	Repeatability	$\pm 1\%$
	Variation	-10 °C to +55 °C
		$f_{nom} - 3\text{ Hz to } f_{nom} + 2\text{ Hz}$
		$\leq 5\%$
		$\leq 5\%$

2.4.3 Operate and Reset Time

	Attribute	Value
t_{basic}	Basic operate time 1x In to 0 A	40 ms
	Operate time	$t_f + t_{basic}, \pm 1\%$ or $\pm 20ms$
	Repeatability	$\pm 1\%$ or $\pm 20ms$
	Variation	$f_{nom} - 3\text{ Hz to } f_{nom} + 2\text{ Hz}$
		harmonics to f_{cutoff}
		$\leq 5\%$

2.5 46NPS Negative Phase Sequence Overcurrent

2.5.1 Reference (46DT)

	Parameter	Value
I_s	Setting	0.05, 0.06... 4.0xIn
t_d	Delay setting	0.00, 0.01...20.00, 20.50... 100, 101... 1000, 1010... 10000, 10100... 14400 s

2.5.2 Operate and Reset Level (46DT)

	Attribute	Value
I_{op}	Operate level	100 % I_s , $\pm 5\%$ or $\pm 1\%$ I_n
	Reset level	$\geq 95\%$ I_{op}
	Repeatability	$\pm 1\%$
	Transient overreach (X/R ≤ 100)	$\leq -5\%$
	Variation	-10 °C to +55 °C
		$f_{nom} - 3$ Hz to $f_{nom} + 2$ Hz

2.5.3 Operate and Reset Time (46DT)

	Attribute	Value
t_{basic}	Element basic operate time	0 to 2 x/s: 40 ms, ± 10 ms
		0 to 5 x/s: 30 ms, ± 10 ms
t_{op}	Operate time following delay	$t_{basic} + t_d$, $\pm 1\%$ or ± 10 ms
	Repeatability	$\pm 1\%$ or ± 10 ms
	Overshoot time	<40 ms
	Disengaging time	< 60 ms

2.5.4 Reference (46IT)

	Parameter	Value
$char$	Characteristic setting	IEC-NI, -VI, -EI, -LTI; ANSI-MI, -VI, -EI; DTL
T_m	Time Multiplier setting	0.025, 0.030... 1.6, 1.7... 5, 6... 100
I_s	Setting	0.05, 0.06... 2.5xIn
t_d	Delay setting	0, 0.01... 20 s
t_{res}	Reset setting	ANSI DECAIVING, 0, 1... 60 s

2.5.5 Operate and Reset Level (46IT)

	Attribute	Value
I_{op}	Operate level	105 % I_s , $\pm 4\%$ or $\pm 1\%$ I_n
	Reset level	$\geq 95\%$ I_{op}
	Repeatability	$\pm 1\%$
	Variation	-10 °C to +55 °C
		$f_{nom} - 3$ Hz to $f_{nom} + 2$ Hz

2.5.6 Operate and Reset Time (46IT)

	Attribute	Value
	Starter operate time ($\geq 2xI_s$)	35 ms, ± 10 ms
t_{op}	Operate time	$char = IEC-NI, IEC-VI, IEC-EI, IEC-LTI$ $t_{op} = \frac{K}{\left[\frac{I}{I_s}\right]^\alpha - 1} \times Tm, \pm 5 \% \text{ absolute or } \pm 50 \text{ ms,}$ for char = IEC-NI : K = 0.14, $\alpha = 0.02$ IEC-VI : K = 13.5, $\alpha = 1.0$ IEC-EI : K = 80.0, $\alpha = 2.0$ IEC-LTI : K = 120.0, $\alpha = 1.0$
		$char = ANSI-MI, ANSI-VI, ANSI-EI$ $t_{op} = \left[\frac{A}{\left[\frac{I}{I_s}\right]^P - 1} + B \right] \times Tm, \pm 5 \% \text{ absolute or } \pm 50 \text{ ms,}$ for char = ANSI-MI : A = 0.0515, B = 0.114, P = 0.02 ANSI-VI : A = 19.61, B = 0.491, P = 2.0 ANSI-EI : A = 28.2, B = 0.1217, P = 2.0
	$char = DTL$	$t_d, \pm 1 \% \text{ or } \pm 20\text{ms}$
	Reset time	$ANSI \text{ DECAYING}$ $t_{res} = \frac{R}{\left[\frac{I}{I_s}\right]^2 - 1} \times Tm, \pm 5 \% \text{ absolute or } \pm 50 \text{ ms,}$ for char = ANSI-MI : R = 4.85 ANSI-VI : R = 21.6 ANSI-EI : R = 29.1
		$t_{res}, \pm 1 \% \text{ or } \pm 20\text{ms}$
	Repeatability	$\pm 1 \% \text{ or } \pm 20\text{ms}$
	Overshoot time	< 40 ms
	Disengaging time	< 60 ms

2.6 49 Thermal Overload

2.6.1 Reference

	Parameter	Value
I_s	Overload setting	0.10, 0.11... 3 xIn
τ	Time constant setting	1, 1.5... 1000 min

2.6.2 Operate and Reset Level

	Attribute	Value
I_{ol}	Overload level	100 % I_s , $\pm 5\%$ or $\pm 1\%$ I_n
	Reset level	$\geq 95\%$ I_{ol}
	Repeatability	$\pm 1\%$
	Variation	-10 °C to +55 °C
		$f_{nom} - 3$ Hz to $f_{nom} + 2$ Hz

2.6.3 Operate and Reset Time

	Attribute	Value
t_{op}	Overload trip operate time	$t = \tau \times \ln \left\{ \frac{I^2 - I_p^2}{I^2 - (k \times I_B)^2} \right\}$ where I_p = prior current
	Repeatability	± 100 ms

Figure 2-1 shows the thermal curves for various time constants.

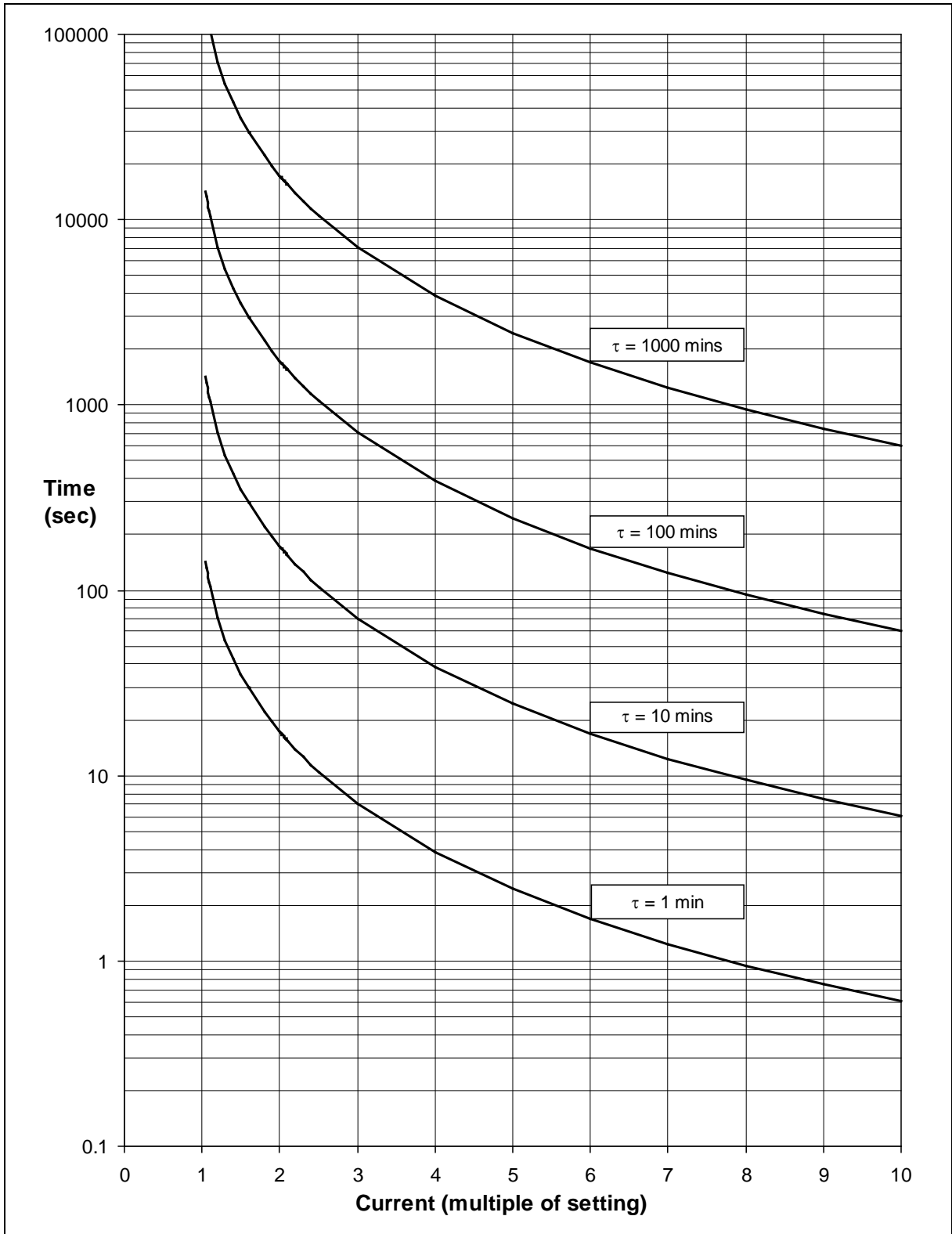

Figure 2-1 Thermal Overload Protection Curves

2.7 50 instantaneous overcurrent

2.7.1 Reference

	Parameter	Value
I_s	Setting	0.05, 0.10... 25, 25.5... 50 $\times I_n$
t_d	Delay setting	0.00, 0.01...20.00, 20.50... 100, 101... 1000, 1010... 10000, 10100... 14400 s

2.7.2 Operate and Reset Level

	Attribute	Value
I_{op}	Operate level	100 % I_s , $\pm 5\%$ or $\pm 1\% I_n$
	Reset level	$\geq 95\% I_{op}$
	Repeatability	$\pm 1\%$
	Transient overreach ($X/R \leq 100$)	$\leq -5\%$
	Variation	-10 °C to +55 °C
		$f_{nom} - 3\text{ Hz}$ to $f_{nom} + 2\text{ Hz}$
		$\leq 5\%$
		$\leq 5\%$

2.7.3 Operate and Reset Time

	Attribute	Value
t_{basic}	Element basic operate time	0 to 2 $\times I_s$: 35 ms, $\pm 10\text{ms}$
		0 to 5 $\times I_s$: 25 ms, $\pm 10\text{ms}$
t_{op}	Operate time following delay	$t_{basic} + t_d$, $\pm 1\%$ or $\pm 10\text{ms}$
	Repeatability	$\pm 1\%$ or $\pm 10\text{ms}$
	Overshoot time	$< 40\text{ ms}$
	Disengaging time	$< 50\text{ ms}$

2.8 50N instantaneous Derived Earth Fault

2.8.1 Reference

	Parameter	Value
I_s	Setting	0.05, 0.10... 25, 25.5... 50 $\times I_n$
t_d	Delay setting	0.00, 0.01...20.00, 20.50... 100, 101... 1000, 1010... 10000, 10100... 14400 s

2.8.2 Operate and Reset Level

	Attribute	Value
I_{op}	Operate level	100 % I_s , $\pm 5\%$ or $\pm 1\% I_n$
	Reset level	$\geq 95\% I_{op}$
	Repeatability	$\pm 1\%$
	Transient overreach ($X/R \leq 100$)	$\leq -5\%$
	Variation	-10 °C to +55 °C
		$f_{nom} - 3\text{ Hz}$ to $f_{nom} + 2\text{ Hz}$
		$\leq 5\%$
		$\leq 5\%$

2.8.3 Operate and Reset Time

	Attribute	Value
t_{basic}	Element basic operate time	0 to 2 $\times I_s$: 35 ms, $\pm 10\text{ms}$
		0 to 5 $\times I_s$: 30 ms, $\pm 10\text{ms}$
t_{op}	Operate time following delay	$t_{basic} + t_d$, $\pm 1\%$ or $\pm 10\text{ms}$
	Repeatability	$\pm 1\%$ or $\pm 10\text{ms}$
	Overshoot time	$< 40\text{ ms}$
	Disengaging time	$< 50\text{ ms}$

2.9 50G Instantaneous Measured Earth Fault

2.9.1 Reference

	Parameter	Value
I_s	Setting	0.005...25.0 xIn
t_d	Delay setting	0.00, 0.01...20.00, 20.50... 100, 101... 1000, 1010... 10000, 10100... 14400 s

2.9.2 Operate and Reset Level

	Attribute	Value
I_{op}	Operate level	100 % I_s , $\pm 5\%$ or $\pm 1\%$ I_n
	Reset level	$\geq 95\%$ I_{op}
	Repeatability	$\pm 1\%$
	Transient overreach ($X/R \leq 100$)	$\leq -5\%$
	Variation	-10 °C to +55 °C
		$f_{nom} - 3\text{ Hz}$ to $f_{nom} + 2\text{ Hz}$
		$\leq 5\%$
		$\leq 5\%$

2.9.3 Operate and Reset Time

	Attribute	Value
t_{basic}	Element basic operate time	0 to 2 xIs: 35 ms, $\pm 10\text{ms}$
		0 to 5 xIs: 25 ms, $\pm 10\text{ms}$
t_{op}	Operate time following delay	$t_{basic} + t_d$, $\pm 1\%$ or $\pm 10\text{ms}$
	Repeatability	$\pm 1\%$ or $\pm 10\text{ms}$
	Overshoot time	$< 40\text{ ms}$
	Disengaging time	$< 50\text{ ms}$

2.10 51 Time Delayed Overcurrent

2.10.1 Reference

	Parameter	Value
I_s	Setting	0.05, 0.1... 2.5 xI_n
$char$	Characteristic setting	IEC-NI, -VI, -EI, -LTI; ANSI-MI, -VI, -EI; DTL
T_m	Time Multiplier setting	0.025, 0.030... 1.6, 1.7... 5, 6... 100
t_d	Delay setting	0, 0.01... 20 s
t_{res}	Reset setting	ANSI DECAIVING, 0, 1... 60 s

2.10.2 Operate and Reset Level

	Attribute	Value
I_{op}	Operate level	105 % I_s , $\pm 4\%$ or $\pm 1\% I_n$
	Reset level	$\geq 95\% I_{op}$
	Repeatability	$\pm 1\%$
	Variation	-10 °C to +55 °C
		$f_{nom} - 3\text{ Hz}$ to $f_{nom} + 2\text{ Hz}$
		$\leq 5\%$
		$\leq 5\%$

2.10.3 Operate and Reset Time

	Attribute	Value
	Starter operate time ($\geq 2xI_s$)	20 ms, ± 20 ms
t_{op}	Operate time	$char = \text{IEC-NI, IEC-VI, IEC-EI, IEC-LTI}$ $t_{op} = \frac{K}{\left[\frac{I}{I_s}\right]^\alpha - 1} \times Tm, \pm 5\% \text{ absolute or } \pm 30 \text{ ms,}$ for char = IEC-NI : K = 0.14, $\alpha = 0.02$ IEC-VI : K = 13.5, $\alpha = 1.0$ IEC-EI : K = 80.0, $\alpha = 2.0$ IEC-LTI : K = 120.0, $\alpha = 1.0$
		$char = \text{ANSI-MI, ANSI-VI, ANSI-EI}$ $t_{op} = \left[\frac{A}{\left[\frac{I}{I_s}\right]^P - 1} + B \right] \times Tm, \pm 5\% \text{ absolute or } \pm 30 \text{ ms,}$ for char = ANSI-MI : A = 0.0515, B = 0.114, P = 0.02 ANSI-VI : A = 19.61, B = 0.491, P = 2.0 ANSI-EI : A = 28.2, B = 0.1217, P = 2.0
	$char = \text{DTL}$	$t_d, \pm 1\% \text{ or } \pm 20\text{ms}$
	Reset time	$ANSI \text{ DECAYING}$ $t_{res} = \frac{R}{\left[\frac{I}{I_s}\right]^2 - 1} \times Tm, \pm 5\% \text{ absolute or } \pm 30 \text{ ms,}$ for char = ANSI-MI : R = 4.85 ANSI-VI : R = 21.6 ANSI-EI : R = 29.1
		t_{res}
	Repeatability	$\pm 1\% \text{ or } \pm 20\text{ms}$
	Overshoot time	< 40 ms
	Disengaging time	< 50 ms

Figure 2-2 shows the operate times for the four IEC IDMTL curves with a time multiplier of 1.

Figure 2-3 and figure 2.4 show the ANSI operate and reset curves. These operate times apply to non-directional characteristics. Where directional control is applied then the directional element operate time should be added to give total maximum operating time.

2.11 51N Time Delayed Derived Earth Fault

2.11.1 Reference

	Parameter	Value
I_s	Setting	0.05, 0.1... 2.5 xI_n
$char$	Characteristic setting	IEC-NI, -VI, -EI, -LTI; ANSI-MI, -VI, -EI; DTL
T_m	Time Multiplier setting	0.025, 0.030... 1.6, 1.7... 5, 6... 100
t_d	Delay setting	0, 0.01... 20 s
t_{res}	Reset setting	ANSI DECAIVING, 0, 1... 60 s

2.11.2 Operate and Reset Level

	Attribute	Value
I_{op}	Operate level	105 % I_s , $\pm 4\%$ or $\pm 1\%$ I_n
	Reset level	$\geq 95\%$ I_{op}
	Repeatability	$\pm 1\%$
	Variation	-10 °C to +55 °C
		$f_{nom} - 3\text{ Hz}$ to $f_{nom} + 2\text{ Hz}$
		$\leq 5\%$
		$\leq 5\%$

2.11.3 Operate and Reset Time

	Attribute	Value
	Starter operate time ($\geq 2xI_s$)	20 ms, ± 20 ms
t_{op}	Operate time	$char = \text{IEC-NI, IEC-VI, IEC-EI, IEC-LTI}$ $t_{op} = \frac{K}{\left[\frac{I}{I_s}\right]^\alpha - 1} \times Tm, \pm 5\% \text{ absolute or } \pm 30 \text{ ms,}$ for char = IEC-NI : K = 0.14, $\alpha = 0.02$ IEC-VI : K = 13.5, $\alpha = 1.0$ IEC-EI : K = 80.0, $\alpha = 2.0$ IEC-LTI : K = 120.0, $\alpha = 1.0$
		$char = \text{ANSI-MI, ANSI-VI, ANSI-EI}$ $t_{op} = \left[\frac{A}{\left[\frac{I}{I_s}\right]^P - 1} + B \right] \times Tm, \pm 5\% \text{ absolute or } \pm 30 \text{ ms,}$ for char = ANSI-MI : A = 0.0515, B = 0.114, P = 0.02 ANSI-VI : A = 19.61, B = 0.491, P = 2.0 ANSI-EI : A = 28.2, B = 0.1217, P = 2.0
	$char = \text{DTL}$	$t_d, \pm 1\% \text{ or } \pm 20\text{ms}$
	Reset time	$ANSI \text{ DECAYING}$ $t_{res} = \frac{R}{\left[\frac{I}{I_s}\right]^2 - 1} \times Tm, \pm 5\% \text{ absolute or } \pm 30 \text{ ms,}$ for char = ANSI-MI : R = 4.85 ANSI-VI : R = 21.6 ANSI-EI : R = 29.1
		t_{res}
	Repeatability	$\pm 1\% \text{ or } \pm 20\text{ms}$
	Overshoot time	< 40 ms
	Disengaging time	< 50 ms

Figure 2-2 shows the operate times for the four IEC IDMTL curves with a time multiplier of 1.

Figure 2-3 and figure 2.4 show the ANSI operate and reset curves. These operate times apply to non-directional characteristics. Where directional control is applied then the directional element operate time should be added to give total maximum operating time.

2.12 51G Time Delayed Measured Earth Fault

2.12.1 Reference

	Parameter	Value	
I_s	Setting	0.005, 0.10... 1.0 x/I_n	
$Char$	Characteristic setting	IEC-NI, -VI, -EI, -LTI; ANSI-MI, -VI, -EI; DTL	
T_m	Time Multiplier setting	0.025, 0.030... 1.6, 1.7... 5, 6... 100	
t_d	Delay setting (DTL)	0, 0.01... 20 s	
t_{res}	Reset setting	ANSI DECAIVING, 0, 1... 60 s	
I	Applied current (for operate time)	IDMTL	2 to 20 x/I_s
		DTL	5 x/I_s

2.12.2 Operate and Reset Level

	Attribute	Value	
I_{op}	Operate level	105 % I_s , ± 4 % or ± 1 % I_n	
	Reset level	≥ 95 % I_{op}	
	Repeatability	± 1 %	
	Variation	-10 °C to +55 °C	≤ 5 %
		$f_{nom} - 3$ Hz to $f_{nom} + 2$ Hz	≤ 5 %

2.12.3 Operate and Reset Time

	Attribute	Value
	Starter operate time ($\geq 2xI_s$)	20 ms, ± 20 ms
t_{op}	Operate time	char = IEC-NI, IEC-VI, IEC-EI, IEC-LTI $t_{op} = \frac{K}{\left[\frac{I}{I_s}\right]^\alpha - 1} \times Tm, \pm 5\% \text{ absolute or } \pm 30 \text{ ms,}$ for char = IEC-NI : K = 0.14, $\alpha = 0.02$ IEC-VI : K = 13.5, $\alpha = 1.0$ IEC-EI : K = 80.0, $\alpha = 2.0$ IEC-LTI : K = 120.0, $\alpha = 1.0$
		char = ANSI-MI, ANSI-VI, ANSI-EI $t_{op} = \left[\frac{A}{\left[\frac{I}{I_s}\right]^P - 1} + B \right] \times Tm, \pm 5\% \text{ absolute or } \pm 30 \text{ ms,}$ for char = ANSI-MI : A = 0.0515, B = 0.114, P = 0.02 ANSI-VI : A = 19.61, B = 0.491, P = 2.0 ANSI-EI : A = 28.2, B = 0.1217, P = 2.0
	char = DTL	$t_d, \pm 1\% \text{ or } \pm 20$ ms
	Reset time	ANSI DECAYING $t_{res} = \frac{R}{\left[\frac{I}{I_s}\right]^2 - 1} \times Tm, \pm 5\% \text{ absolute or } \pm 30 \text{ ms,}$ for char = ANSI-MI : R = 4.85 ANSI-VI : R = 21.6 ANSI-EI : R = 29.1
		t_{res}
	Repeatability	$\pm 1\% \text{ or } \pm 20$ ms
	Overshoot time	< 40 ms
	Disengaging time	< 50 ms

Figure 2-2 shows the operate times for the four IEC IDMTL curves with a time multiplier of 1.

Figure 2-3 and figure 2.4 show the ANSI operate and reset curves. These operate times apply to non-directional characteristics. Where directional control is applied then the directional element operate time should be added to give total maximum operating time.

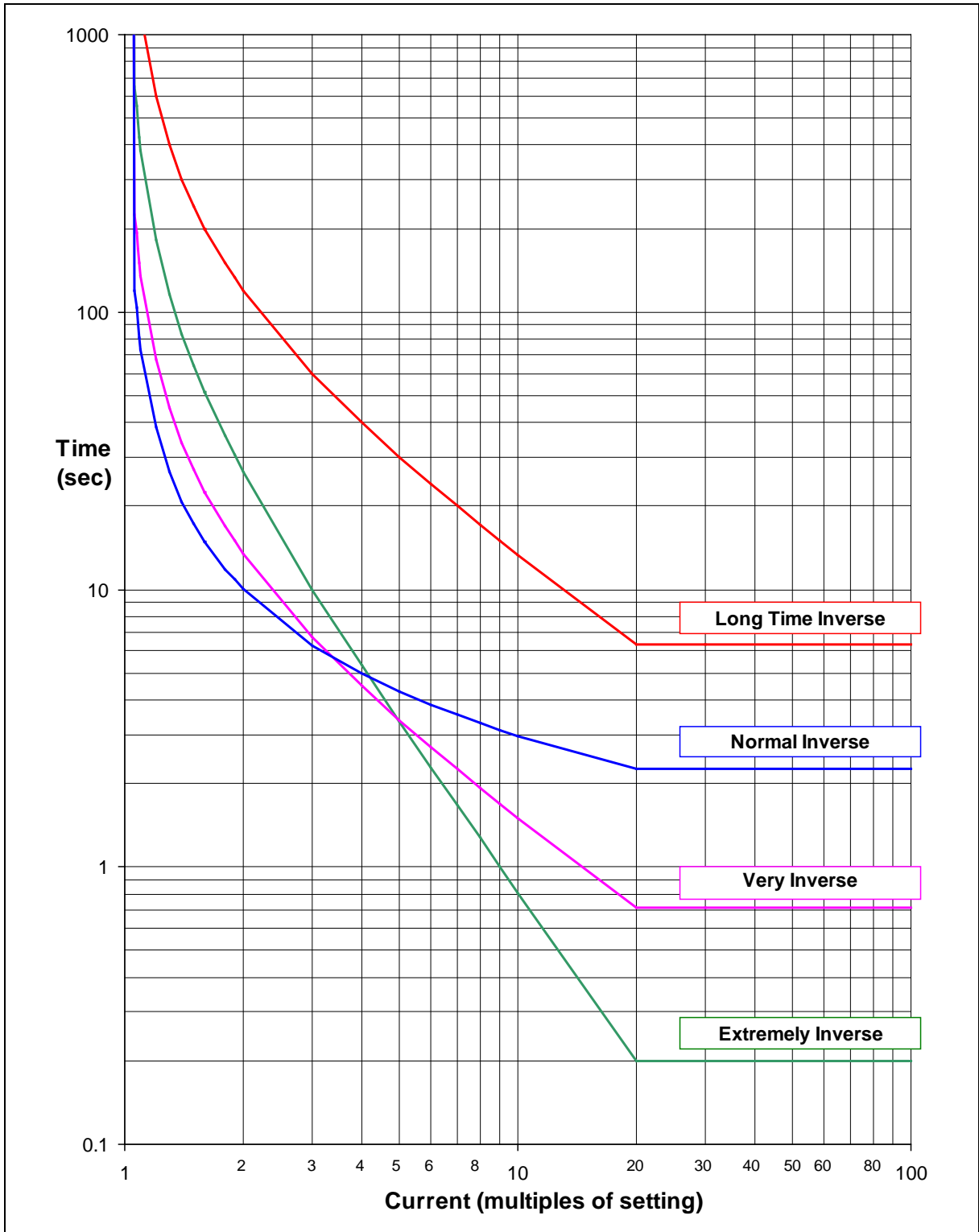

Figure 2-2 IEC IDMTL Curves (Time Multiplier=1)

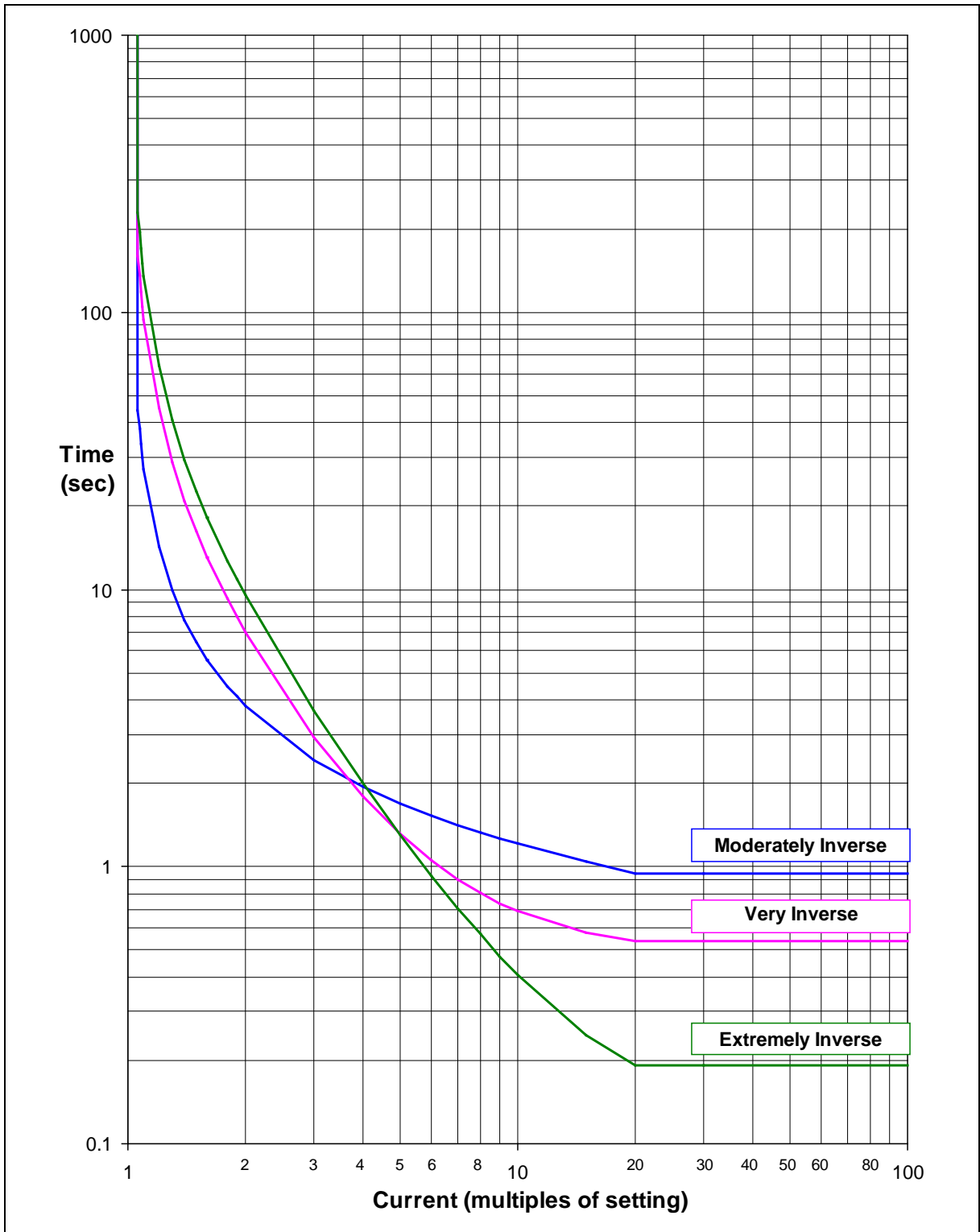

Figure 2-3 ANSI IDMTL Operate Curves (Time Multiplier=1)

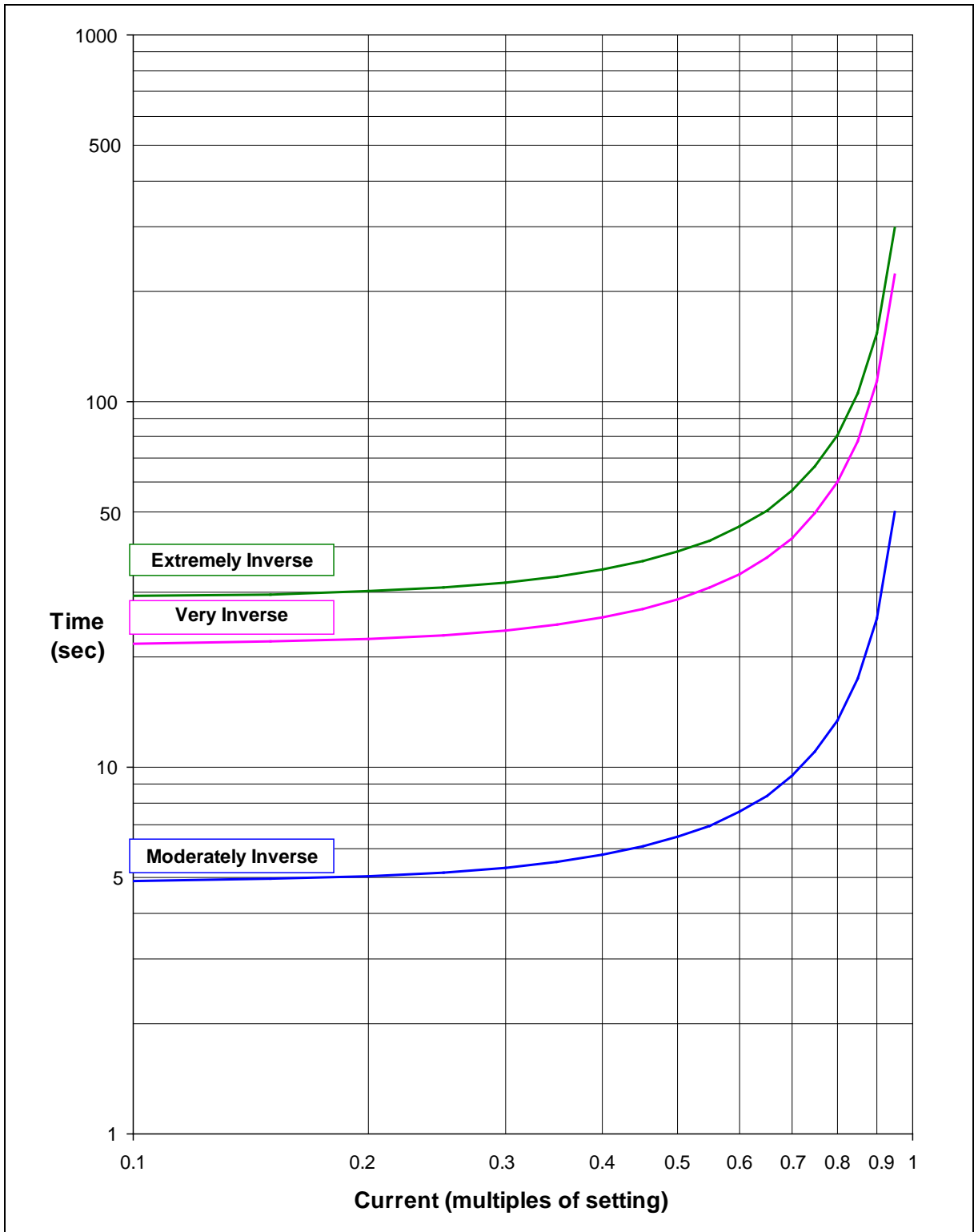

Figure 2-4 ANSI Reset Curves (Time Multiplier=1)

2.13 59N Neutral Voltage Displacement

2.13.1 Reference (59NDT)

	Parameter	Value
V_s	Setting	1, 1.5... 100V
t_d	Delay setting	0.00, 0.01...20.00, 20.50... 100, 101... 1000, 1010... 10000, 10100... 14400 s

2.13.2 Operate and Reset Level (59NDT)

	Attribute	Value
V_{op}	Operate level	100 % V_s , $\pm 2\%$ or $\pm 0.5\text{ V}$
	Reset level	$\geq 95\%$ V_{op}
	Repeatability	$\pm 1\%$
	Variation	-10 °C to +55 °C
		$f_{nom} - 3\text{ Hz}$ to $f_{nom} + 2\text{ Hz}$
		$\leq 5\%$
		$\leq 5\%$

2.13.3 Operate and Reset Time (59NDT)

	Attribute	Value
t_{basic}	Element basic operate time	0V to 1.5 x V_s , 76 ms, $\pm 20\text{ms}$
		0V to 10 x V_s , 63 ms, $\pm 20\text{ms}$
t_{op}	Operate time following delay	$t_{basic} + t_d$, $\pm 1\%$ or $\pm 20\text{ms}$
	Repeatability	$\pm 1\%$ or $\pm 20\text{ms}$
	Overshoot time	$< 40\text{ ms}$
	Disengaging time	$< 50\text{ ms}$

2.13.4 Reference (59NIT)

	Parameter	Value
M	Multiplier setting	0.1, 0.2... 10, 10.5... 140
V_s	Setting	1, 1.5... 100V
t_d	Delay setting	0, 0.01... 20 s
t_{res}	Reset setting	0, 1...60 s

2.13.5 Operate and Reset Level (59NIT)

	Attribute	Value
V_{op}	Operate level	105 % V_s , $\pm 2\%$ or $\pm 0.5\text{ V}$
	Reset level	$\geq 95\%$ V_{op}
	Repeatability	$\pm 1\%$
	Variation	-10 °C to +55 °C
		$f_{nom} - 3\text{ Hz}$ to $f_{nom} + 2\text{ Hz}$
		$\leq 5\%$
		$\leq 5\%$

2.13.6 Operate and Reset Time (59NIT)

	Attribute		Value
t_{basic}	Starter operate time ($\geq 2xV_s$)		65 ms, ± 20 ms
t_{op}	Operate time	char = IDMTL	$t_{op} = \frac{M}{\left[\frac{3V_0}{V_s}\right] - 1}$, $\pm 5\%$ or ± 65 ms
		char = DTL	t_d , $\pm 1\%$ or ± 40 ms
	Reset Time	char = IDMTL	t_{res} , $\pm 5\%$ or ± 65 ms
		char = DTL	t_{res} , $\pm 1\%$ or ± 40 ms
	Repeatability		$\pm 1\%$ or ± 20 ms
	Overshoot time		< 40 ms
	Disengaging time		< 50 ms

2.14 64H Restricted Earth Fault Protection

2.14.1 Reference

	Parameter	Value
I_s	Setting	0.005, 0.010... 0.95 xI_n
t_d	Delay setting	0.00, 0.01... 20.0, 20.1... 100.0, 101....1000, 1010 ... 10000 , 10100 ... 14400 s

2.14.2 Operate and Reset Level

	Attribute	Value
I_{op}	Operate level	100 % I_s , $\pm 5\%$ or $\pm 1\% xI_n$
	Reset level	95 % I_{op} , $\pm 5\%$ or $\pm 0.1\% xI_n$
	Repeatability	$\pm 1\%$
	Transient overreach ($X/R \leq 100$)	$\leq -5\%$
	Variation	-10 °C to +55 °C
		$f_{nom} - 3\text{ Hz}$ to $f_{nom} + 2\text{ Hz}$
		$\leq 5\%$
		$\leq 5\%$

2.14.3 Operate and Reset Time

	Attribute	Value
t_{basic}	Element basic operate time	0 to 2 xI_s , 40 ms, $\pm 10\text{ms}$
		0 to 5 xI_s , 30 ms, $\pm 10\text{ms}$
t_{op}	Operate time following delay	$t_{basic} + t_d$, $\pm 1\%$ or $\pm 10\text{ms}$
	Repeatability	$\pm 1\%$ or $\pm 10\text{ms}$
	Overshoot time	< 40 ms
	Disengaging time	< 50 ms

2.14.4 Harmonic Rejection

	Harmonic Rejection 2 nd to 15 th harmonic	40:1 minimum (50/60Hz)
--	--	------------------------

2.15 81Under/Over Frequency

2.15.1 Reference

	Parameter	Value
F_s	Setting	40, 40.01... 69.99 Hz
$Hyst$	Hysteresis setting	0, 0.1... 80%
t_d	Delay setting	0.00, 0.01... 20.0, 20.1... 100.0, 101....1000, 1010 ... 10000 , 10100 ... 14400 s

2.15.2 Operate and Reset Level

	Attribute	Value
F_{op}	Operate level	100 % F_s , $\pm 10\text{mHz}$
	Reset level	overfrequency (100 % - $hyst$) $\times F_{op}$, $\pm 10\text{mHz}$
		underfrequency (100 % + $hyst$) $\times F_{op}$, $\pm 10\text{mHz}$
	Repeatability	$\pm 1\%$
	Variation	-10 °C to +55 °C $\leq 5\%$

2.15.3 Operate and Reset Time

	Attribute	Value	
t_{basic}	Element basic operate time (for ROCOF between 0.1 and 5.0 Hz/sec)	overfrequency	Typically < 110ms Maximum < 150ms
		underfrequency	Typically < 110ms Maximum < 150ms
	t_{op}	Operate time following delay	$t_{basic} + t_d$, $\pm 1\%$ or $\pm 10\text{ms}$
		Repeatability	$\pm 1\%$ or $\pm 10\text{ms}$
	Disengaging time	< 100 ms	

2.16 87 Biased Differential

2.16.1 Reference

	Parameter	Value
I_{CT}	Multiplier	1.00x
I_{init}	Initial Setting	0.1, 0.15... 2 xIn
I_{B1}	1 st Bias Slope setting	0.1, 0.15... 0.7 x
I_{B1L}	1 st Bias Slope Limit	1, 2... 20 xIn
I_{B2}	2 nd Bias Slope setting	1, 1.05... 2 x
I_{B2T}	2 nd Bias Slope Type setting	Line, Curve
t_s	Delay setting	0, 0.005... 1s

2.16.2 Operate and Reset Level

	Attribute	Value
I_{OP}	Operate level 2 nd Bias Slope Type = Line	$I_{OPERATE} > I_{87INITIAL SETTING}$ and $I_{OPERATE} > M_1 \times I_{RESTRAIN}$ and $I_{OPERATE} > M_2 \times I_{RESTRAIN}$ (for $I_{RESTRAIN} > B$) Where $I_{OPERATE} = I_1 + I_2 $ $I_{RESTRAIN} = \frac{ I_1 + I_2 }{2}$ B = 87BD 1 st Bias slope limit M ₁ = 87BD 1 st Bias slope M ₂ = 87BD 2 nd Bias slope
	Operate level 2 nd Bias Slope Type = Curve	$I_{OPERATE} > I_{87INITIAL SETTING}$ and $I_{OPERATE} > M_1 \times I_{RESTRAIN}$ and $I_{OPERATE} > \sqrt{\frac{I_{RESTRAIN}^2 - K^2}{2}}$ (for $I_{RESTRAIN} > B$) Where $K^2 = B^2 - 2M_1^2B^2$
	87BD Operate Level	$\pm 10\%$ of I_{OP} or $\pm 0.1In$
	Reset level	$\geq 90\%$ of I_{OP}
	Repeatability	$\pm 2\%$
	Transient overreach	$\leq 5\%$
Variation	-10 °C to +55 °C	
	$f_{nom} - 3$ Hz to $f_{nom} + 2$ Hz	

2.16.3 Operate Time

	Attribute	Value
t_{basic}	Element basic operate time	$3 \times I_{OP}$, 35 ms, ± 10 ms
	Switched from 0 to $x I_{OP}$ (Inrush Action: Enabled)	$10 \times I_{OP}$, 30 ms, ± 10 ms
t_{op}	Operate time following delay	$t_{basic} + t_d$, $\pm 1\%$ or ± 10 ms

2.17 87HS High-Set Differential

2.17.1 Reference

	Parameter	Value
I_{CT}	Multiplier	1.00x
I_s	Setting	1, 2 ... 30 xIn
t_s	Delay setting	0, 0.005... 1s

2.17.2 Operate and Reset Level

	Attribute	Value
I_{op}	Operate level	$\pm 5\%$ of setting or $\pm 0.01I_n$
	Reset level	$\geq 95\%$ of I_{OP}
	Repeatability	$\pm 2\%$
	Transient overreach	$\leq 5\%$
	Variation	-10 °C to +55 °C
		$f_{nom} - 3 \text{ Hz}$ to $f_{nom} + 2 \text{ Hz}$

2.17.3 Operate and Reset Time

	Attribute	Value
t_{basic}	Element basic operate time	$3 \times I_{OP}$, 30 ms, $\pm 10\text{ms}$
	Switched from 0 to x I_{OP}	$5 \times I_{OP}$, 25 ms, $\pm 10\text{ms}$
t_{op}	Operate time following delay	$t_{basic} + t_d$, $\pm 1\%$ or $\pm 10\text{ms}$

Section 3: Supervision Functions

3.1 50BF Circuit Breaker Fail

3.1.1 Reference

	Parameter	Value
I_s	Setting: 50BF-n	0.050, 0.055... 2.0 xIn
I_s	Setting: 50BF-n-I4	0.005, 0.010... 2.0 xIn
t_{CBF1}	Stage 1 Delay setting	0, 5... 60000ms
t_{CBF2}	Stage 2 Delay setting	0, 5... 60000ms

3.1.2 Operate and Reset Level

	Attribute	Value
I_{op}	Operate level	100 % I_s , $\pm 5\%$ or $\pm 1\%$ I_n
I_{reset}	Reset level	<100 % I_{op} , $\pm 5\%$ or $\pm 1\%$ I_n
	Repeatability	$\pm 1\%$
	Variation	-10 °C to +55 °C
		$f_{nom} - 3\text{ Hz}$ to $f_{nom} + 2\text{ Hz}$

3.1.3 Operate and Reset Time

	Attribute	Value
t_{basic}	Element basic operate time	< 20ms
t_{op}	Stage 1	t_{CBF1} , $\pm 1\%$ or $\pm 20\text{ms}$
	Stage 2	t_{CBF2} , $\pm 1\%$ or $\pm 20\text{ms}$
	Repeatability	$\pm 1\%$ or $\pm 20\text{ms}$
	Overshoot	< 2 x 20ms
	Disengaging time	< 20ms

3.2 74TCS/CCS Trip/Close Circuit Supervision

3.2.1 Reference

	Parameter	Value
t_d	Delay setting	0, 0.02...60 s

3.2.2 Operate and Reset Time

	Attribute	Value
t_{basic}	Element basic operate time	30ms \pm 10ms
t_{op}	Operate time following delay	$t_{basic} + t_d, \pm 1 \% \text{ or } \pm 10\text{ms}$
	Repeatability	$\pm 1 \% \text{ or } \pm 10\text{ms}$
	Variation	-10 °C to +55 °C
		$f_{nom} - 3 \text{ Hz to } f_{nom} + 2 \text{ Hz}$
		$\leq 5 \%$
		$\leq 5 \%$

3.3 81HBL2 Inrush Detector

3.3.1 Reference

	Parameter	Value
<i>I</i>	Setting (Ratio of 2nd Harmonic current to Fundamental component current)	0.10, 0.11... 0.5

3.3.2 Operate and Reset Level

	Attribute	Value
<i>I_{op}</i>	Operate level	100 % <i>I</i> , ± 4 % or ± 1% <i>I_n</i>
	Reset level	100 % <i>I_{op}</i> , ± 4 % or ± 1% <i>I_n</i>
	Repeatability	± 1 %
	Variation	-10 °C to +55 °C
		<i>f_{nom}</i> - 3 Hz to <i>f_{nom}</i> + 2 Hz
		≤ 5 %
		≤ 5 %

3.3.3 Operate and Reset Time

	Attribute	Value
<i>t_{basic}</i>	Element basic operate time	Will pick-up before operation of any protection element due to magnetic inrush
	Reset Time	Will operation until drop-off of any protection element due to magnetic inrush

3.4 81HBL5 Overfluxing Detector

3.4.1 Reference

	Parameter	Value
<i>I</i>	Setting (Ratio of 5th Harmonic current to Fundamental component current)	0.10, 0.11... 0.5

3.4.2 Operate and Reset Level

	Attribute	Value
<i>I_{op}</i>	Operate level	100 % <i>I</i> , ± 4 % or ± 1% <i>I_n</i>
	Reset level	100 % <i>I_{op}</i> , ± 4 % or ± 1% <i>I_n</i>
	Repeatability	± 1 %
	Variation	-10 °C to +55 °C
		<i>f_{nom}</i> - 3 Hz to <i>f_{nom}</i> + 2 Hz
		≤ 5 %
		≤ 5 %

3.4.3 Operate and Reset Time

	Attribute	Value
<i>t_{basic}</i>	Element basic operate time	Will pick-up before operation of any protection element due to overfluxing
	Reset Time	Will operation until drop-off of any protection element due to overfluxing

7SR242 Duobias

Multi-Function 2-Winding Transformer Protection Relay

Document Release History

This document is issue 2017/12. The list of revisions up to and including this issue is:

2017/12	Software revision 2662H85001 R8e-7e
2017/08	Software revision 2662H85001 R8c-7d
2013/01	Software revision 2662H85001 R7c-7b
2012/08	Addition of optional IEC 61850 communication protocol and Ethernet Interface.
2010/06	Additional Comms modules option of (RS485 + IRIG-B) and (RS232 + IRIG-B) and typographical revisions
2010/02	Document reformat due to rebrand
2010/02	Software revision 2662H80001 R4c-3
2008/07	Software revision 2662H80001R3d-2c.
2008/05	First issue

Software Revision History

2017/12	2662H85001 R8e-7e	Universal PSU
2017/08	2662H85001 R8c-7d	Phase currents added to 61850. 5A metering corrected
2013/01	2662H85001 R7c-7b	Revised file handling during shutdown
2012/08	2662H85001 R7b-7a	Addition of optional IEC 61850 communication protocol and Ethernet.
2010/02	2662H80001 R4c-3	Revisions to: VT ratio settings, 87BD 1 st bias slope limit setting increments, CB fail function, LED CONFIG menu, DATA STORAGE menu. Added: Open circuit detection (46BC), CONTROL MODE menu, Close circuit supervision (74CCS), Measured earth fault undercurrent (37G), Pulsed output contacts.
2008/07	2662H80001R3d-2c.	Demand metering. Optional DNP3.0 data comms.
2008/05	2662H80001R3-2b	First Release

The copyright and other intellectual property rights in this document, and in any model or article produced from it (and including any registered or unregistered design rights) are the property of Siemens Protection Devices Limited. No part of this document shall be reproduced or modified or stored in another form, in any data retrieval system, without the permission of Siemens Protection Devices Limited, nor shall any model or article be reproduced from this document unless Siemens Protection Devices Limited consent.

While the information and guidance given in this document is believed to be correct, no liability shall be accepted for any loss or damage caused by any error or omission, whether such error or omission is the result of negligence or any other cause. Any and all such liability is disclaimed.

Contents

Document Release History	1
Software Revision History	1
Section 1: Introduction	4
Section 2: Physical Connection.....	5
2.1 Communication ports	6
2.1.1 USB Interface (COM2).....	6
2.1.2 RS485 Interface (COM1)	7
2.1.3 Optional Rear Fibre Optic Interfaces (COM3 and COM4).....	8
2.1.4 Optional Rear RS485 (COM3)	12
2.1.5 Optional Rear RS232 (COM3)	12
2.1.6 Optional Rear EN100 Ethernet Module (COM3)	13
Section 3: IEC 60870-5-103 Definitions	14
3.1 Introduction	14
Section 4: Modbus Definitions.....	22
4.1 Introduction	22
Event Format	30
Section 5: DNP3.0 Definitions.....	31
5.1 Device Profile	31
5.2 Implementation Table.....	34
5.3 Point List	44
5.3.1 Double Bit Binary Input Points	49
5.3.2 Binary Counters	53
5.3.3 Frozen Counters	54
Section 6: IEC61850 Protocol Support	58
Section 7: Modems	59
7.1.1 Connecting a Modem to the Relay(s).....	59
7.1.2 Setting the Remote Modem	59
7.1.3 Connecting to the Remote Modem	59
Section 8: Glossary.....	60

List of Figures

Figure 2-1	Communication to Front USB Port	6
Figure 2-2	Communication to Multiple Devices using RS485 (Standard Port).....	7
Figure 2-3	Communication to Multiple Devices using Fibre-optic Ring Network.....	11
Figure 2-4	Communication to Multiple Devices from Control System and Laptop using Fibre-optic Star Network	11
Figure 2-5	Additional (Optional) Rear RS485 + IRIG-B Connection to a PC	12
Figure 2-6	Additional (Optional) Rear RS232 + IRIG-B Connection to a PC	12
Figure 2-7	RS232 Data Comms Pin Connections.....	12
Figure 2-8	EN100 Ethernet Module	13

Section 1: Introduction

This section provides information on the use of the Communication Interface with a control system or interrogating computer. Appropriate software within the control system or on the interrogating computer (e.g. Reydisp Evolution) is required to access the interface.

The relay data communication facility incorporates user selectable protocols to provide compatibility with control and automation systems.

This section specifies connection details and lists the events, commands and measurands available in the IEC60870-5-103, Modbus RTU, DNP3.0 and optional IEC61850 protocols.

When IEC60870-5-103 protocol is selected the relay can communicate with PCs running Reydisp software which provides operational information, post-fault analysis, settings interrogation and editing facilities etc. Reydisp software can be downloaded from our website www.energy.siemens.com.

Section 2: Physical Connection

As standard the relay provides one 'Front' USB communication interface (COM2) located on the fascia and one RS485 (COM1) located on the 'Rear'.

Optionally additional fibre optic (x2), RS232 (x1), RS485 (x1) or Ethernet comms ports can be provided on the rear, these are designated COM3 or COM4 as detailed below.

1. COM1-RS485: this port can be used for IEC60870-5-103, MODBUS RTU or optionally DNP3 communications to a substation SCADA or integrated control system or engineer remote access.
2. COM2-USB: this port is used for IEC60870-5-103 (default setting) communication with Reydisp software. MODBUS RTU or optional DNP3 are also available via COM2.

An ASCII protocol, the main use of which is to allow firmware to be updated from the front connection, is also available through this port.

Access to COM2 settings is only available from the relay front fascia via the **COMMUNICATIONS MENU**
3. COM3: Located on the rear of the relay this optional port can be used for IEC60870-5-103, MODBUS RTU, DNP 3 or optional IEC6185 communications to a substation SCADA, integrated control system or for engineer remote access.
4. COM4: Located on the rear of the relay this optional port can be used for IEC60870-5-103, MODBUS RTU or DNP3 communications to a substation SCADA or integrated control system or engineer remote access.

SPDL can provide a range of interface devices, please refer to product portfolio catalogue.

Full details of the interface devices can be found by referring to the website www.siemens.com/energy.

2.1 Communication ports

To allow communication to the relay the Station Address setting must be within the range of the selected protocol i.e. 0 – 254 for IEC60870-5-103, 0 – 247 for MODBUS-RTU or 0 – 65520 for DNP3.

Setting name	Range	Default	Setting	Notes
Station Address	0 ... 65534	0		An address within the range of the relevant protocol must be given to identify the relay. Each relay must have a unique address.

2.1.1 USB Interface (COM2)

The USB communication port is connected using a standard USB cable with a type B connection to the relay and type A to the PC.

The PC will require a suitable USB driver to be installed, this will be carried out automatically when the Reydisp software is installed. When the Reydisp software is running with the USB cable connected to a device an additional connection is shown. Connections to these devices are not shown when they are not connected.

The USB communication interface on the relay is labelled Com 2 and its associated settings are located in the Data communications menu. To enable communication with Reydisp via the USB port the following setting changes must be made from the relay fascia.

Setting name	Range	Default	Setting	Notes
Station Address	0 ... 65534	0	0 – 254	
COM2-USB Protocol	OFF, IEC60870-5-103, MODBUS-RTU, ASCII, DNP3	IEC60870-5-103	IEC60870-5-103	Reydisp software is compatible with IEC60870-5-103.
COM2-USB Mode	Local, Local or Remote, Remote	Local	Local	

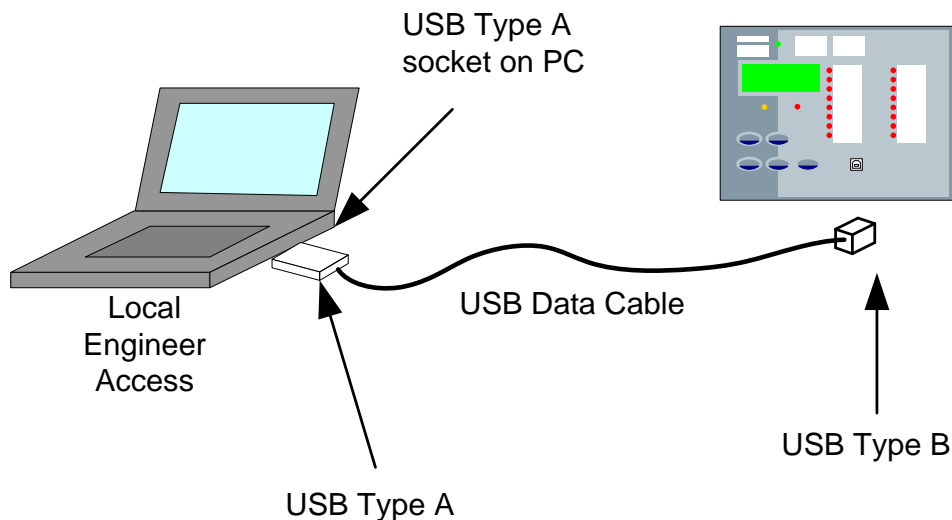

Figure 2-1 Communication to Front USB Port

2.1.2 RS485 Interface (COM1)

The RS485 communication port is located on the rear of the relay and can be connected using a suitable RS485 120 Ohm screened twisted pair cable.

The RS485 electrical connection can be used in a single or multi-drop configuration. The RS485 master must support and use the Auto Device Enable (ADE) feature. The last device in the connection must be terminated correctly in accordance with the master device driving the connection. The relays are fitted with an internal terminating resistor which can be connected between A and B by fitting an external wire loop between terminals 18 and 20 on the power supply module.

The maximum number of relays that can be connected to the bus is 64.

Each relay has an internal terminating resistor – this can be connected in circuit where necessary.

The following settings must be configured when using the RS485 interface.

Setting name	Range	Default	Setting	Notes
COM1-RS485 Protocol	OFF, IEC60870-5-103, MODBUS-RTU, DNP3.0	IEC60870-5-103	As Required	Sets the protocol used to communicate on the standard RS485 connection.
COM1-RS485 Baud Rate	75 110 150 300 600 1200 2400 4800 9600 19200 38400	19200	As Required	The baud rate set on all of the relays connected to the control system must be the same as the one set on the master device.
COM1-RS485 Parity	NONE, ODD, EVEN	EVEN	As Required	The parity set on all of the relays connected to the control system must be the same and in accordance with the master device.
COM1-RS485 Mode	Local, Local or Remote, Remote	Remote		
Unsolicited Mode	DISABLED ENABLED	DISABLED	As Required	Setting is only visible when COM1 Protocol is set to DNP3
Destination Address	0 ... 65520	0	As Required	Setting is only visible when DNP3 Unsolicited Events set to Enabled.

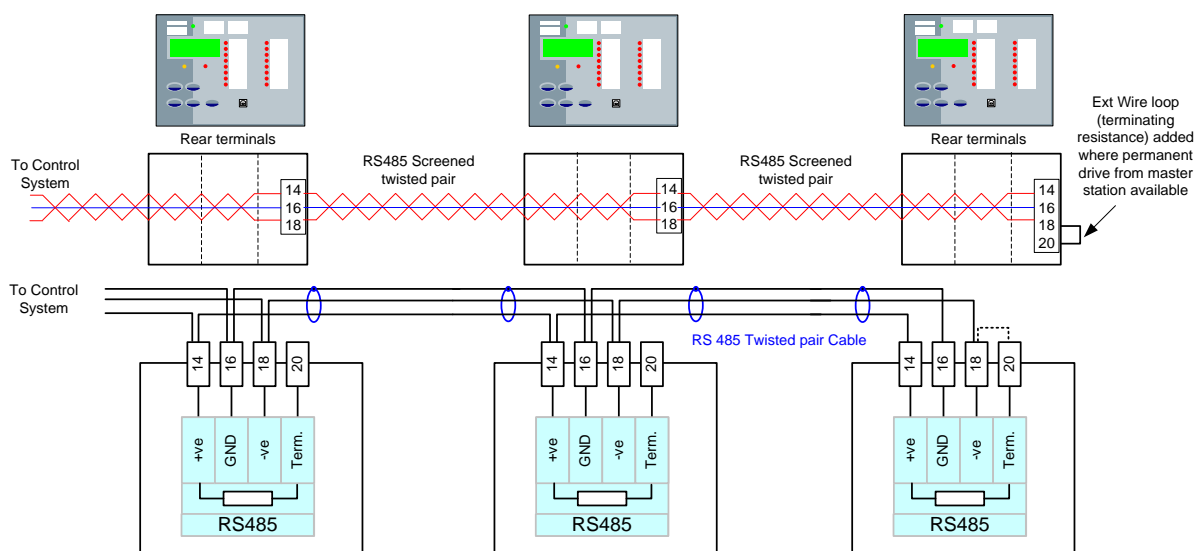

Figure 2-2 Communication to Multiple Devices using RS485 (Standard Port)

2.1.3 Optional Rear Fibre Optic Interfaces (COM3 and COM4)

When connecting via the optional fibre optic interface the selection of fibre-optic cable is important. Fibres must be terminated with STTM (BFOC/2.5) connectors.

The recommended type is 62.5/125µm glass fibre. Communication distances over 1 km are achievable using this type of fibre.

The fibre optic data comms link will be interrupted if the relay element is withdrawn from the case.

A budget loss calculation should be made for all installations. The following table gives the launch power and receiver sensitivity of each of the fibre optic communication ports on the Argus M relay when used with specific fibre optic types.

Fibre Type	Tx Launch Power (dB)		RX Receive Sensitivity (dB)	
	Min	Max	Min	Max
62.5/125µm	-11.7	-15.7	-24	-9.2
1mm Polymer	-6.4	-10.4	-24	-9.2
200µm PCS	-2.8	-6.8	-24	-9.2

Factors to be considered when calculating fibre-optic transmission distances:

- Transmitter launch power
- Attenuation, based on light frequency, fibre material and fibre diameter
- Number of intermediate connectors and splices
- Receiver sensitivity
- The light power at the receiver must be above the sensitivity of the receiver in order that effective communication can occur.
- Fibre cables are supplied on reels of finite length which may necessitate additional jointing.
- Typical losses at connectors are 0.5-1.0dB each. This allows for normal age related deterioration. Consult manufacturers data for actual values.
- Typical Splice losses are <0.3dB.
- A 3dB safety margin is usually allowed after the budget calculation is performed.

Following installation and prior to putting into service the actual losses should be measured for each fibre using a calibrated light source and meter. Measured and calculated values can be compared.

The following table can be used to record budget calculations:

A	Launch power	dB
B	Fibre Type	
C	Loss (dB/km)	dB/km
D	Length	km
E	Total fibre loss (CxD)	dB
F	No. of Splices	
G	Loss at each splice	dB
H	Total loss at splices (FxG)	dB
I	No. of connectors	
J	Loss per connector	dB
K	Total loss at connectors (IxJ)	dB
L	Total losses (E+H+K)	dB
M	Receive power budget (A-L)	dB
N	Safety Margin	dB
O	Device Receive Sensitivity	dB

Setting name	Range	Default	Setting	Notes
Station Address	1 – 254 for IEC60870-5-103 0 – 247 for Modbus RTU 0 – 65520 for DNP3.0	0	As Required	An address within the range of the relevant protocol must be given to identify the relay. Each relay must have a unique address.
COM3 Protocol	OFF, IEC60870-5-103, MODBUS-RTU, DNP3.0	IEC60870-5-103	As Required	Sets the protocol used to communicate on the connection – Com3
COM3 Baud Rate	75 110 150 300 600 1200 2400 4800 9600 19200 38400 57600 115200	19200	As Required	The baud rate set on all of the relays connected to the control system must be the same as the one set on the master device.
COM3 Parity	NONE, ODD, EVEN	EVEN	As Required	The parity set on all of the relays connected to the control system must be the same and in accordance with the master device.
COM3 Line Idle*	LIGHT ON, LIGHT OFF	LIGHT OFF	As Required	Sets the idle state of the line in accordance with master device
COM3 Data Echo*	ON,OFF	OFF	As Required	Set to ON when relays are connected in a ring configuration.
COM4 Protocol**	OFF, IEC60870-5-103, MODBUS-RTU, DNP3.0	IEC60870-5-103	As Required	Sets the protocol used to communicate on the connection – Com4.
COM4 Baud Rate**	75 110 150 300 600 1200 2400 4800 9600 19200 38400	19200	As Required	The baud rate set on all of the relays connected to the control system must be the same as the one set on the master device.
COM4 Parity**	NONE, ODD, EVEN	EVEN	As Required	The parity set on all of the relays connected to the control system must be the same and in accordance with the master device.
COM4 Line Idle**	LIGHT ON, LIGHT OFF	LIGHT OFF	As Required	Sets the idle state of the line in accordance with master device
COM4 Data Echo**	ON,OFF	OFF	As Required	Set to ON when relays are connected in a ring configuration.

*Not applicable for RS 485 or RS 232 options

**COM 4 is fibre optic only

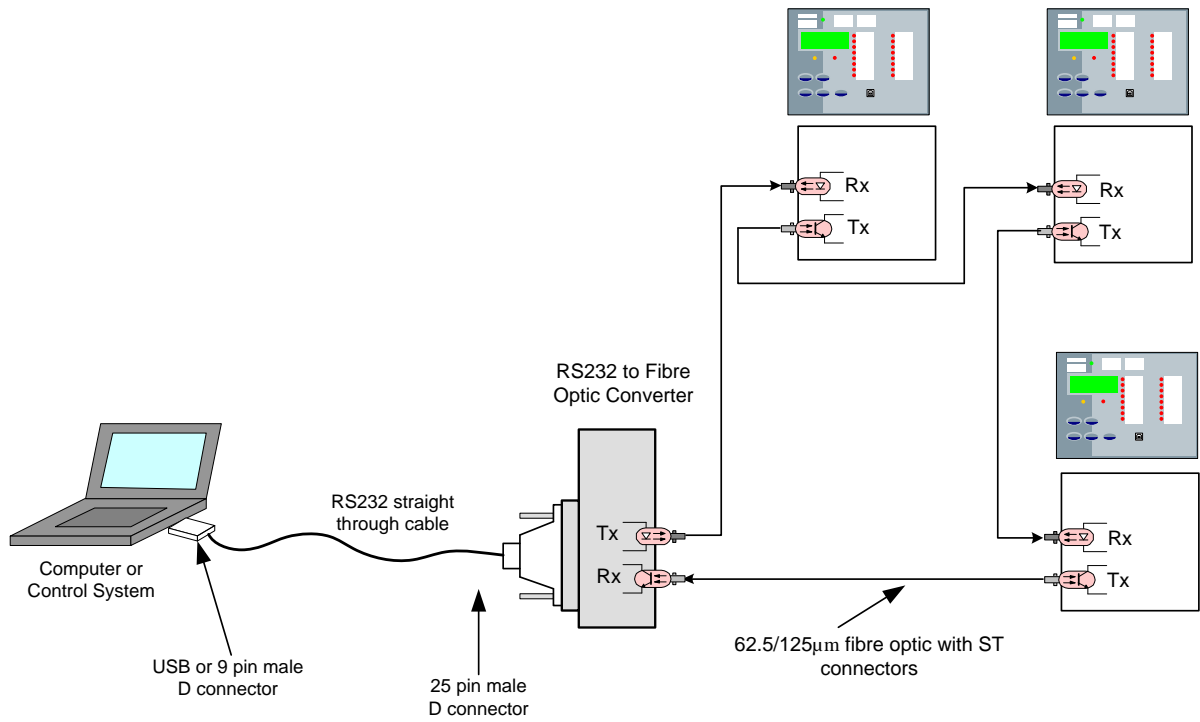

Figure 2-3 Communication to Multiple Devices using Fibre-optic Ring Network

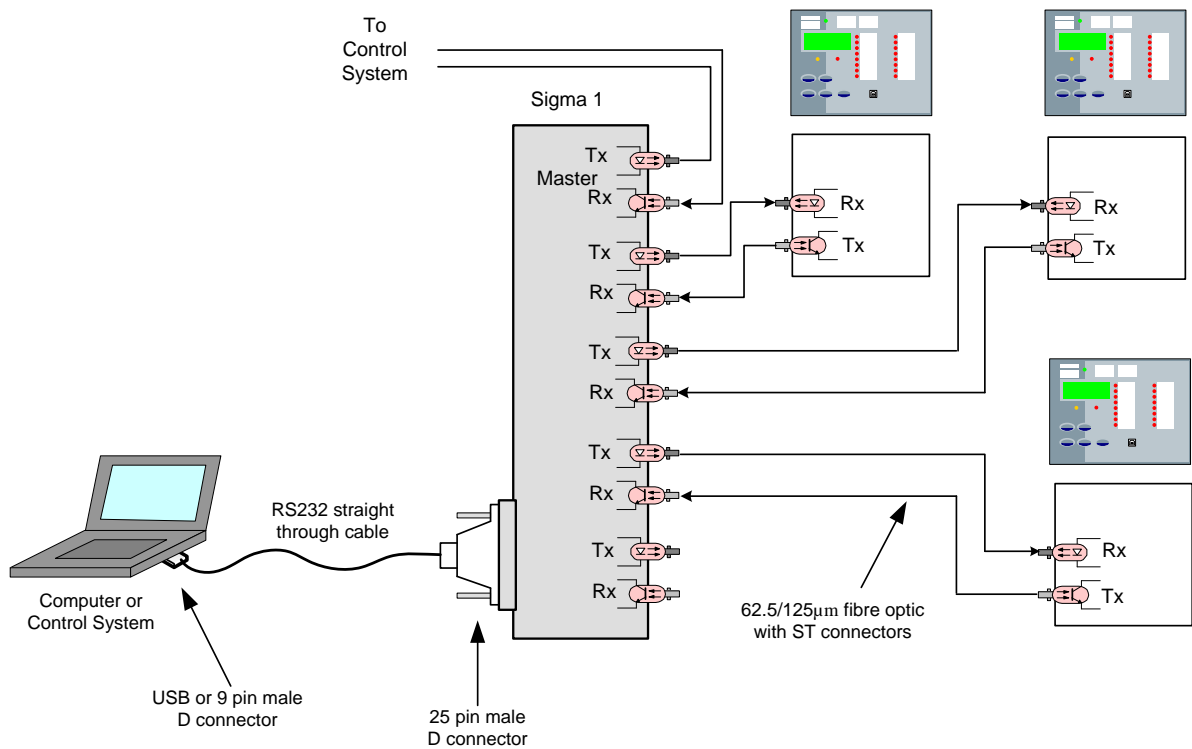

Figure 2-4 Communication to Multiple Devices from Control System and Laptop using Fibre-optic Star Network

2.1.4 Optional Rear RS485 (COM3)

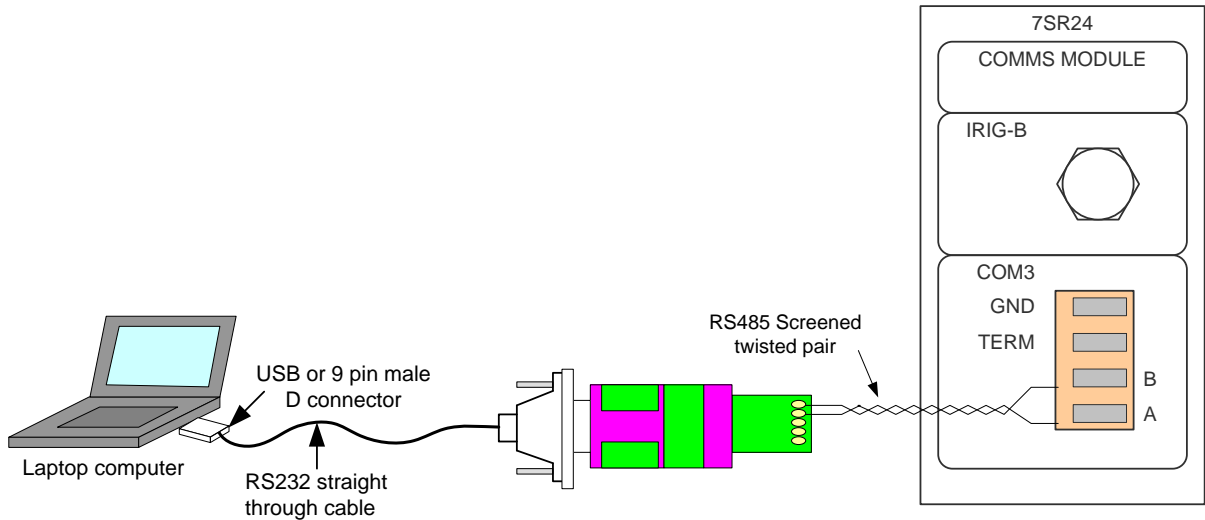

Figure 2-5 Additional (Optional) Rear RS485 + IRIG-B Connection to a PC

2.1.5 Optional Rear RS232 (COM3)

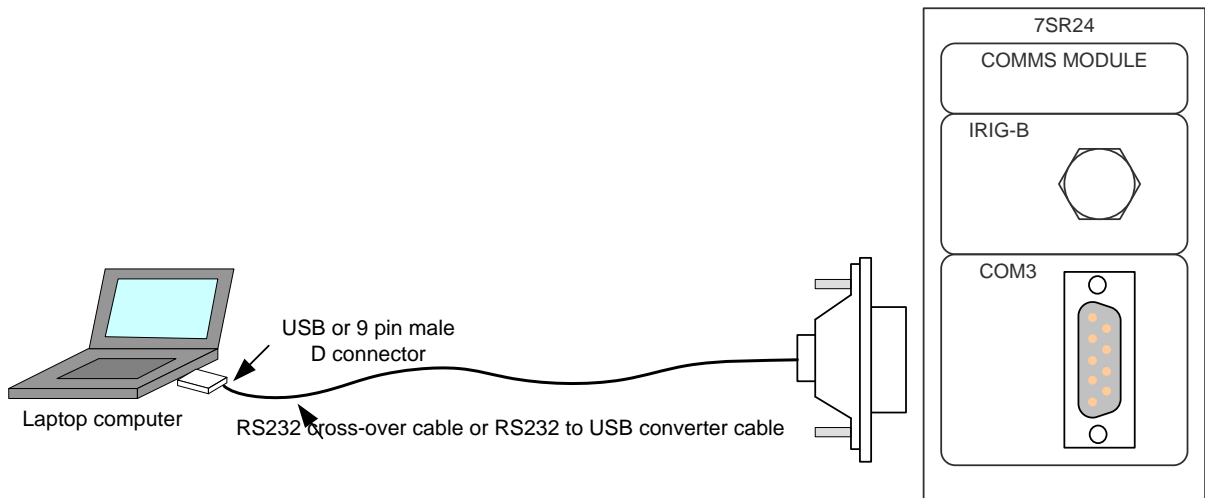

Figure 2-6 Additional (Optional) Rear RS232 + IRIG-B Connection to a PC

Pin	Relay Function
1	Not Connected
2	Receive Data (RXD)
3	Transmit Data (TXD)
4	Output Supply +5V 50mA
5	Signal Ground (GND)
6	Output Supply +5V 50mA
7	Linked to 8 (volts free)
8	Linked to 7 (volts free)
9	Output Supply +5V 50mA

Figure 2-7 RS232 Data Comms Pin Connections

2.1.6 Optional Rear EN100 Ethernet Module (COM3)

The optional ethernet interface is primarily provided for support of IEC 61850 protocol. Support for IEC 60870-5-103 is also provided over this interface to allow connection with Reydisp Evolution and Reydisp Manager software for interrogation, editing and download of relay settings and other data. Ordering options are available with two RJ45 electrical connectors or with two duplex LC fibre optic connectors.

Setting name	Range	Default	Setting	Notes
LAN Protocol	OFF, IEC60870-5-103	IEC60870-5-103		

If this setting is set to Off, access to relay data using Reydisp Evolution and Reydisp Manager software via the Ethernet interface is not available.

Connections to the optional EN100 ethernet module are made on the rear underside of the relay. Connections are made to either RJ45 sockets (electrical) or Duplex LC (fibre optic) connectors.

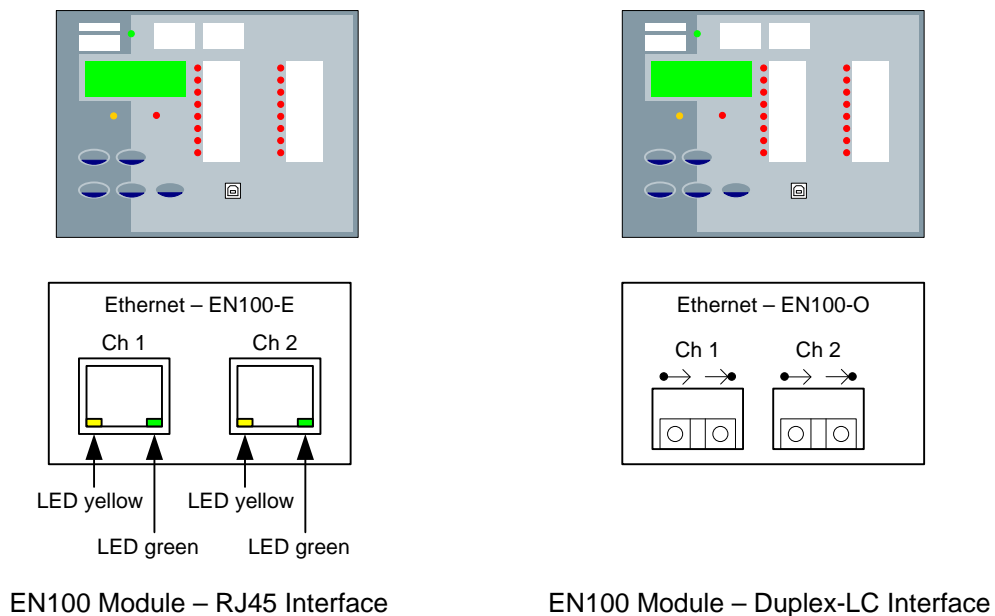

Green LED (Physical Link)
 Off – No link
 On – Link present

Yellow LED (Activity)
 Off – No traffic
 On/flashing - Traffic

Figure 2-8 EN100 Ethernet Module

Section 3: IEC 60870-5-103 Definitions

3.1 Introduction

This section describes the IEC 60870-5-103 protocol implementation in the relays. This protocol is used for the communication with REYDISP software and can also be used for communication with a suitable control system. The control system or local PC acts as the master in the system with the relay operating as a slave responding to the master's commands. The implementation provides event information, time synchronising, commands and measurands and also supports the transfer of disturbance records.

This protocol can be set to use any or all of the relays hardware interfaces (USB, Fibre Optic and RS485) and is the standard protocol used by the USB port. The relay can communicate simultaneously on all ports regardless of protocol used.

Each relay must be given an address to enable communication and can be set by the *Communication Interface:Relay Address*. Valid settings are within the range **1 – 254**, a relay with the default address of **0** will not be able to communicate.

Cause of Transmission

The cause of transmission (COT) column of the 'Information Number and Function' table lists possible causes of transmission for these frames. The following abbreviations are used:

Abbreviation	Description
SE	spontaneous event
T	test mode
GI	general interrogation
Loc	local operation
Rem	remote operation
Ack	command acknowledge
Nak	Negative command acknowledge

Note: Events listing a GI cause of transmission can be raised and cleared; other events are raised only.

Function Type

Abbreviation	Description
1	Time tagged message (monitor direction)
2	Time tagged message (relative time) (monitor direction)
3.1	Measurands I
4	Time-tagged measurands with relative time
5	Identification message
6	Time synchronisation
7	General Interrogation Initialization
9	Measurands II
20	General command

Information Number and Function

The following table lists information number and function definitions together with a description of the message and function type and cause of transmission that can result in that message. Definitions with shaded area are not available on all relay models.

Function	Information Number	Description	Function Type	Cause of Transmission
60	4	Remote Mode	1	SE, GI,
			20	Ack, Nak
60	5	Out of Service Mode	1	SE, GI,
			20	Ack, Nak
60	6	Local Mode	1	SE, GI,
			20	Ack, Nak
60	7	Local & Remote Mode	1	SE, GI,
			20	Ack, Nak
60	12	Control Received	1	SE
60	13	Command Received	1	SE
60	128	Cold Start	1	SE
60	129	Warm Start	1	SE
60	130	Re-start	1	SE
60	131	Expected Restart	1	SE, GI
60	132	Unexpected Restart	1	SE, GI
60	135	Trigger Storage	1	SE
60	136	Clear Waveform Records	1	SE
60	137	Clear Fault Records	1	SE
60	138	Clear Event Records	1	SE
60	140	Demand metering reset	1	SE
60	170	General Alarm 1	1	SE, GI,
60	171	General Alarm 2	1	SE, GI,
60	172	General Alarm 3	1	SE, GI,
60	173	General Alarm 4	1	SE, GI,
60	174	General Alarm 5	1	SE, GI,
60	175	General Alarm 6	1	SE, GI,
60	176	General Alarm 7	1	SE, GI,
60	177	General Alarm 8	1	SE, GI,
60	178	General Alarm 9	1	SE, GI,
60	179	General Alarm 10	1	SE, GI,
60	180	General Alarm 11	1	SE, GI,
60	181	General Alarm 12	1	SE, GI,
60	182	Quick Logic E1	1	SE, GI,
60	183	Quick Logic E2	1	SE, GI,
60	184	Quick Logic E3	1	SE, GI,
60	185	Quick Logic E4	1	SE, GI,
60	186	Quick Logic E5	1	SE, GI,
60	187	Quick Logic E6	1	SE, GI,
60	188	Quick Logic E7	1	SE, GI,
60	189	Quick Logic E8	1	SE, GI,
60	190	Quick Logic E9	1	SE, GI,
60	191	Quick Logic E10	1	SE, GI,
60	192	Quick Logic E11	1	SE, GI,
60	193	Quick Logic E12	1	SE, GI,
60	194	Quick Logic E13	1	SE, GI,
60	195	Quick Logic E14	1	SE, GI,
60	196	Quick Logic E15	1	SE, GI,
60	197	Quick Logic E16	1	SE, GI,
70	5	Binary Input 5	1	SE, GI,
70	6	Binary Input 6	1	SE, GI,

Function	Information Number	Description	Function Type	Cause of Transmission
70	7	Binary Input 7	1	SE, GI,
70	8	Binary Input 8	1	SE, GI,
70	9	Binary Input 9	1	SE, GI,
70	10	Binary Input 10	1	SE, GI,
70	11	Binary Input 11	1	SE, GI,
70	12	Binary Input 12	1	SE, GI,
70	13	Binary Input 13	1	SE, GI,
70	14	Binary Input 14	1	SE, GI,
70	15	Binary Input 15	1	SE, GI,
70	16	Binary Input 16	1	SE, GI,
70	17	Binary Input 17	1	SE, GI,
70	18	Binary Input 18	1	SE, GI,
70	19	Binary Input 19	1	SE, GI,
75	1	Virtual Input 1	1	SE, GI
75	2	Virtual Input 2	1	SE, GI
75	3	Virtual Input 3	1	SE, GI
75	4	Virtual Input 4	1	SE, GI
75	5	Virtual Input 5	1	SE, GI
75	6	Virtual Input 6	1	SE, GI
75	7	Virtual Input 7	1	SE, GI
75	8	Virtual Input 8	1	SE, GI
75	9	Virtual Input 9	1	SE, GI
75	10	Virtual Input 10	1	SE, GI
75	11	Virtual Input 11	1	SE, GI
75	12	Virtual Input 12	1	SE, GI
75	13	Virtual Input 13	1	SE, GI
75	14	Virtual Input 14	1	SE, GI
75	15	Virtual Input 15	1	SE, GI
75	16	Virtual Input 16	1	SE, GI
80	1	Binary Output 1	1	SE, GI,
			20	Ack, Nak
80	2	Binary Output 2	1	SE, GI,
			20	Ack, Nak
80	3	Binary Output 3	1	SE, GI,
			20	Ack, Nak
80	4	Binary Output 4	1	SE, GI,
			20	Ack, Nak
80	5	Binary Output 5	1	SE, GI,
			20	Ack, Nak
80	6	Binary Output 6	1	SE, GI,
			20	Ack, Nak
80	7	Binary Output 7	1	SE, GI,
			20	Ack, Nak
80	8	Binary Output 8	1	SE, GI,
			20	Ack, Nak
80	9	Binary Output 9	1	SE, GI,
			20	Ack, Nak
80	10	Binary Output 10	1	SE, GI,
			20	Ack, Nak
80	11	Binary Output 11	1	SE, GI,

Function	Information Number	Description	Function Type	Cause of Transmission
			20	Ack, Nak
80	12	Binary Output 12	1	SE, GI,
			20	Ack, Nak
80	13	Binary Output 13	1	SE, GI,
			20	Ack, Nak
80	14	Binary Output 14	1	SE, GI,
			20	Ack, Nak
90	1	Led 1	1	SE, GI
90	2	Led 2	1	SE, GI
90	3	Led 3	1	SE, GI
90	4	Led 4	1	SE, GI
90	5	Led 5	1	SE, GI
90	6	Led 6	1	SE, GI
90	7	Led 7	1	SE, GI
90	8	Led 8	1	SE, GI
90	9	Led 9	1	SE, GI
90	10	Led 10	1	SE, GI
90	11	Led 11	1	SE, GI
90	12	Led 12	1	SE, GI
90	13	Led 13	1	SE, GI
90	14	Led 14	1	SE, GI
90	15	Led 15	1	SE, GI
90	16	Led 16	1	SE, GI
90	17	Led 17	1	SE, GI
90	18	Led 18	1	SE, GI
90	19	Led 19	1	SE, GI
90	20	Led 20	1	SE, GI
90	21	Led 21	1	SE, GI
90	22	Led 22	1	SE, GI
90	23	Led 23	1	SE, GI
90	24	Led 24	1	SE, GI
91	1	Led PU 1	1	SE, GI
91	2	Led PU 2	1	SE, GI
91	3	Led PU 3	1	SE, GI
91	4	Led PU 4	1	SE, GI
91	5	Led PU 5	1	SE, GI
91	6	Led PU 6	1	SE, GI
91	7	Led PU 7	1	SE, GI
91	8	Led PU 8	1	SE, GI
91	9	Led PU 9	1	SE, GI
91	10	Led PU 10	1	SE, GI
91	11	Led PU 11	1	SE, GI
91	12	Led PU 12	1	SE, GI
91	13	Led PU 13	1	SE, GI
91	14	Led PU 14	1	SE, GI
91	15	Led PU 15	1	SE, GI
91	16	Led PU 16	1	SE, GI
91	17	Led PU 17	1	SE, GI
91	18	Led PU 18	1	SE, GI
91	19	Led PU 19	1	SE, GI

Function	Information Number	Description	Function Type	Cause of Transmission
91	20	Led PU 20	1	SE, GI
91	21	Led PU 21	1	SE, GI
91	22	Led PU 22	1	SE, GI
91	23	Led PU 23	1	SE, GI
91	24	Led PU 24	1	SE, GI
176	0	Data lost	5	Data lost
176	2	Reset FCB	5	Reset FCB
176	3	Reset CU	5	Reset CU
176	4	Start/Restart	5	Start/Restart
176	5	Power On	5	SE
176	19	LEDs reset (Reset Flag & Outputs)	1	SE
			20	Ack, Nak
176	22	Settings changed	1	SE
176	23	Settings Group 1 Select	1	SE, GI
			20	Ack, Nak
176	24	Settings Group 2 Select	1	SE, GI
			20	Ack, Nak
176	25	Settings Group 3 Select	1	SE, GI
			20	Ack, Nak
176	26	Settings Group 4 Select	1	SE, GI
			20	Ack, Nak
176	27	Binary Input 1	1	SE, GI
176	28	Binary Input 2	1	SE, GI
176	29	Binary Input 3	1	SE, GI
176	30	Binary Input 4	1	SE, GI
176	36	Trip circuit fail	1	SE, GI
176	48	EF L1	2	SE
176	49	EF L2	2	SE
176	50	EF L3	2	SE
176	64	Starter/Pick Up L1	1	SE, GI
176	65	Starter/Pick Up L2	1	SE, GI
176	66	Starter/Pick Up L3	1	SE, GI
176	67	Starter/Pick Up N	1	SE, GI
176	68	General Trip	2	SE
176	69	Trip L1	2	SE
176	70	Trip L2	2	SE
176	71	Trip L3	2	SE
176	84	General Starter/Pick Up	1	SE, GI
177	8	87BD	2	SE, GI
177	9	87HS	2	SE, GI
177	10	51-1	2	SE, GI
177	11	50-1	2	SE, GI
177	12	51N-1	2	SE, GI
177	13	50N-1	2	SE, GI
177	14	51G-1	2	SE, GI
177	15	50G-1	2	SE, GI
177	16	51-2	2	SE, GI
177	17	50-2	2	SE, GI
177	18	51N-2	2	SE, GI
177	19	50N-2	2	SE, GI

Function	Information Number	Description	Function Type	Cause of Transmission
177	20	51G-2	2	SE, GI
177	21	50G-2	2	SE, GI
177	26	51G-3	2	SE, GI
177	32	51G-4	2	SE, GI
177	34	50BF-1-1	2	SE, GI
177	35	50BF-1-2	2	SE, GI
177	36	50BF-2-1	2	SE, GI
177	37	50BF-2-2	2	SE, GI
177	38	Thermal Alarm	2	SE, GI
177	39	Thermal Trip	2	SE, GI
177	41	46IT-1	2	SE, GI
177	42	46DT-1	2	SE, GI
177	43	46IT-2	2	SE, GI
177	44	46DT-2	2	SE, GI
177	45	64H-1	2	SE, GI
177	46	64H-2	2	SE, GI
177	48	37-1	2	SE, GI
177	49	37-2	2	SE, GI
177	52	27/59-1	2	SE, GI
177	53	27/59-2	2	SE, GI
177	54	27/59-3	2	SE, GI
177	55	27/59-4	2	SE, GI
177	56	59NIT	2	SE, GI
177	57	59NDT	2	SE, GI
177	58	81-1	2	SE, GI
177	59	81-2	2	SE, GI
177	60	81-3	2	SE, GI
177	61	81-4	2	SE, GI
177	62	81-5	2	SE, GI
177	63	81-6	2	SE, GI
177	64	24DT-1	2	SE, GI
177	65	24DT-2	2	SE, GI
177	66	24IT	2	SE, GI
177	67	Trip Circuit Fail 1	2	SE, GI
177	68	Trip Circuit Fail 2	2	SE, GI
177	69	Trip Circuit Fail 3	2	SE, GI
177	70	Trip Circuit Fail 4	2	SE, GI
177	71	Trip Circuit Fail 5	2	SE, GI
177	72	Trip Circuit Fail 6	2	SE, GI
177	77	Settings Group 5 Selected	1	SE, GI
			20	Ack, Nak
177	78	Settings Group 6 Selected	1	SE, GI
			20	Ack, Nak
177	79	Settings Group 7 Selected	1	SE, GI
			20	Ack, Nak
177	80	Settings Group 8 Selected	1	SE, GI
			20	Ack, Nak
177	83	CB 1 Total Trip Count	1	SE, GI
177	84	CB 1 Delta Trip Count	1	SE, GI
177	86	Reset CB 1 Total Trip Count	1	SE, GI

Function	Information Number	Description	Function Type	Cause of Transmission
			20	Ack, Nak
177	87	Reset CB 1 Delta Trip Count	1	SE, GI
			20	Ack, Nak
177	89	I ² t CB 1 Wear	1	SE, GI
177	90	Reset I ² t CB 1 Wear	1	SE, GI
			20	Ack, Nak
177	91	I ² t CB 2 Wear	1	SE, GI
177	92	Reset I ² t CB 2 Wear	1	SE, GI
			20	Ack, Nak
177	93	CB 2 Total Trip Count	1	SE, GI
177	94	CB 2 Delta Trip Count	1	SE, GI
177	96	Reset CB 2 Total Trip Count	1	SE, GI
			20	Ack, Nak
177	97	Reset CB 2 Delta Trip Count	1	SE, GI
			20	Ack, Nak
177	99	81HBL2	2	SE, GI
177	100	81HBL5	2	SE, GI
177	101	CB 1 Total Trip Count	2	SE, GI
177	102	CB 1 Delta Trip Count	2	SE, GI
177	103	37G-1	2	SE, GI
177	104	37G-2	2	SE, GI
177	105	Close CB1	2	SE, GI
177	106	CB1 Fail To Close	2	SE, GI
177	107	CB1 DBI	2	SE, GI
177	108	Open CB1	2	SE, GI
177	109	CB1 Fail To Open	2	SE, GI
177	110	Close CB2	2	SE, GI
177	111	CB2 Fail To Close	2	SE, GI
177	112	CB2 DBI	2	SE, GI
177	113	Open CB2	2	SE, GI
177	114	CB2 Fail To Open	2	SE, GI
177	115	Close Circuit Fail 1	2	SE, GI
177	116	Close Circuit Fail 2	2	SE, GI
177	117	Close Circuit Fail 3	2	SE, GI
177	118	Close Circuit Fail 4	2	SE, GI
177	119	Close Circuit Fail 5	2	SE, GI
177	120	Close Circuit Fail 6	2	SE, GI
177	125	CB1 Trip Time Alarm	2	SE, GI
177	126	CB2 Trip Time Alarm	2	SE, GI
177	127	E/F Out	2	SE, GI
177	128	CB 2 Total Trip Count	2	SE, GI
177	129	CB 2 Delta Trip Count	2	SE, GI
178	63	Trip General	2	SE, GI
178	64	Trip Phase A	2	SE, GI
178	65	Trip Phase B	2	SE, GI
178	66	Trip Phase C	2	SE, GI
178	70	W1 Ia	4	SE, GI
178	71	W1 Ib	4	SE, GI
178	72	W1 Ic	4	SE, GI
178	73	W2 Ia	4	SE, GI

Function	Information Number	Description	Function Type	Cause of Transmission
178	74	W2 Ib	4	SE, GI
178	75	W2 Ic	4	SE, GI
178	76	V	4	SE, GI
178	77	Ig-1	4	SE, GI
178	78	Ig-2	4	SE, GI
200	1	CB1	1	SE, GI
			20	Ack, Nak
200	2	CB2	1	SE, GI
			20	Ack, Nak
200	255	Blocked by Interlocking	1	
255	0	GI Initiation	7	End of GI
255	0	GI End	8	End of GI
255	0	Time Synchronisation	6	Time Synchronisation

Measurand

Function	Information Number	Description	Function Type	Cause of Transmission
178	230	<u>W1</u> I _{L1,2,3} I _{L1} (2.4 x) I _{L2} (2.4 x) I _{L3} (2.4 x)	9	Cyclic – Refresh rate 5 seconds or value change greater than 1%.
178	231	<u>W2</u> I _{L1,2,3} I _{L1} (2.4 x) I _{L2} (2.4 x) I _{L3} (2.4 x)	9	Cyclic – Refresh rate 5 seconds or value change greater than 1%.
178	220	<u>V,f</u> V (1.2 x) f (1.2 x)	9	Cyclic – Refresh rate 5 seconds or value change greater than 1%.

Disturbance Recorder Actual Channel (ACC) Numbers

Function	ACC Number	Description
183	0	Global
183	1	W1 Ia
183	2	W1 Ib
183	3	W1 Ic
183	4	IG1
183	5	W2 Ia
183	6	W2 Ib
183	7	W2 Ic
183	8	IG2
183	9	Vx

Section 4: Modbus Definitions

4.1 Introduction

This section describes the MODBUS-RTU protocol implementation in the relays. This protocol is used for communication with a suitable control system.

This protocol can be set to use the Fibre Optic and RS485 ports. The relay can communicate simultaneously on all ports regardless of protocol used.

Each relay must be given an address to enable communication and can be set by the *Communication Interface:Relay Address*. Valid settings are within the range **1 – 247**, a relay with the default address of **0** will not be able to communicate.

Definitions with shaded area are not available on all relay models.

Coils (Read Write Binary values)

Address	Description
00001	Binary Output 1
00002	Binary Output 2
00003	Binary Output 3
00004	Binary Output 4
00005	Binary Output 5
00006	Binary Output 6
00007	Binary Output 7
00008	Binary Output 8
00009	Binary Output 9
00010	Binary Output 10
00011	Binary Output 11
00012	Binary Output 12
00013	Binary Output 13
00014	Binary Output 14
00100	LED Reset (Write only location)
00101	Settings Group 1
00102	Settings Group 2
00103	Settings Group 3
00104	Settings Group 4
00105	Settings Group 5
00106	Settings Group 6
00107	Settings Group 7
00108	Settings Group 8
00109	CB1
00110	CB2
00111	Reset CB1 Total Trip Count, write only location.
00112	Reset CB1 Delta Trip Count, write only location.
00113	Reset CB1 Lockout Trip Count, write only location.
00114	Reset I ² t CB1 Wear, write only location.
00115	Reset I ² t CB2 Wear, write only location.
00116	Reset CB2 Total Trip Count, write only location.
00117	Reset CB2 Delta Trip Count, write only location.
00118	Reset CB2 Lockout Trip Count, write only location.
00119	Demand Metering Reset
00120	Local Mode
00121	Remote Mode
00122	Service Mode
00123	Local & Remote Mode
00124	E/F Out

Inputs (Read Only Binary values)

Address	Description
10001	Binary Input 1
10002	Binary Input 2
10003	Binary Input 3
10004	Binary Input 4
10005	Binary Input 5
10006	Binary Input 6
10007	Binary Input 7
10008	Binary Input 8
10009	Binary Input 9
10010	Binary Input 10
10011	Binary Input 11
10012	Binary Input 12
10013	Binary Input 13
10014	Binary Input 14
10015	Binary Input 15
10016	Binary Input 16
10017	Binary Input 17
10018	Binary Input 18
10019	Binary Input 19
10101	General Start/Pick-up
10102	General Trip
10103	Start/Pick-up L1
10104	Start/Pick-up L2
10105	Start/Pick-up L3
10106	Start/Pick-up N
10107	Trip/Operation L1
10108	Trip/Operation L2
10109	Trip/Operation L3
10110	Trip/Operation N
10111	Trip Circuit Fail
10120	LOCAL Mode
10121	REMOTE Mode
10122	SERVICE Mode
10123	Local & Remote
10130	Trip Cct Fail 1
10131	Trip Cct Fail 2
10132	Trip Cct Fail 3
10133	Trip Cct Fail 4
10134	Trip Cct Fail 5
10135	Trip Cct Fail 6
10200	87 Operated A
10201	87 Operated B
10202	87 Operated C
10203	87 Harmonic Detector A
10204	87 Harmonic Detector B
10205	87 Harmonic Detector C
10206	87 BD
10207	87HS Operated A
10208	87HS Operated B
10209	87HS Operated C
10210	87HS Trip
10220	64H-1 Operated
10221	64H-1 Starter
10223	64H-2 Operated
10224	64H-2 Starter
10225	64H-3 Operated
10226	64H-3 Starter
10230	51G-1 Starter
10231	51G-1 Operated
10233	51G-2 Starter
10234	51G-2 Operated
10242	UVGuardBlock

10243	27/59-1 Operated
10244	27/59-1 Starter
10246	27/59-2 Operated
10247	27/59-2 Starter
10249	27/59-3 Operated
10250	27/59-3 Starter
10252	27/59-4 Operated
10253	27/59-4 Starter
10260	81-1 Operated
10261	81-1 Starter
10263	81-2 Operated
10264	81-2 Starter
10266	81-3 Operated
10267	81-3 Starter
10269	81-4 Operated
10270	81-4 Starter
10272	81-5 Operated
10273	81-5 Starter
10275	81-6 Operated
10276	81-6 Starter
10280	24DT-1 Operated
10281	24DT-1 Starter
10283	24DT-2 Operated
10284	24DT-2 Starter
10286	24IT Starter
10287	24IT Operated
10290	49 Trip
10291	49 Alarm
10310	50G-1 Operated
10311	50G-1 Starter
10320	50G-2 Operated
10321	50G-2 Starter
10333	51G-3 Starter
10334	51G-3 Operated
10336	51G-4 Starter
10337	51G-4 Operated
10501	Virtual Input 1
10502	Virtual Input 2
10503	Virtual Input 3
10504	Virtual Input 4
10505	Virtual Input 5
10506	Virtual Input 6
10507	Virtual Input 7
10508	Virtual Input 8
10509	Virtual Input 9
10510	Virtual Input 10
10511	Virtual Input 11
10512	Virtual Input 12
10513	Virtual Input 13
10514	Virtual Input 14
10515	Virtual Input 15
10516	Virtual Input 16
10601	Led 1
10602	Led 2
10603	Led 3
10604	Led 4
10605	Led 5
10606	Led 6
10607	Led 7
10608	Led 8
10609	Led 9
10610	Led 10
10611	Led 11
10612	Led 12

10613	Led 13
10614	Led 14
10615	Led 15
10616	Led 16
10617	Led 17
10618	Led 18
10619	Led 19
10620	Led 20
10621	Led 21
10622	Led 22
10623	Led 23
10624	Led 24
10701	Led PU 1
10702	Led PU 2
10703	Led PU 3
10704	Led PU 4
10705	Led PU 5
10706	Led PU 6
10707	Led PU 7
10708	Led PU 8
10709	Led PU 9
10710	Led PU 10
10711	Led PU 11
10712	Led PU 12
10713	Led PU 13
10714	Led PU 14
10715	Led PU 15
10716	Led PU 16
10717	Led PU 17
10718	Led PU 18
10719	Led PU 19
10720	Led PU 20
10721	Led PU 21
10722	Led PU 22
10723	Led PU 23
10724	Led PU 24
10800	Cold Start
10801	Warm Start
10802	Re-Start
10803	Power On
10804	SW Forced Restart
10805	Unexpected Restart
10806	Reset Start Count
12100	51-1 Starter A
12101	51-1 Starter B
12102	51-1 Starter C
12103	51-1 Operated A
12104	51-1 Operated B
12105	51-1 Operated C
12107	50-1 Starter A
12108	50-1 Starter B
12109	50-1 Starter C
12110	50-1 Operated A
12111	50-1 Operated B
12112	50-1 Operated C
12114	51N-1 Starter
12115	51N-1 Operated
12117	50N-1 Starter
12118	50N-1 Operated
12120	51-1
12121	50-1
12200	51-2 Starter A
12201	51-2 Starter B
12202	51-2 Starter C

12203	51-2 Operated A
12204	51-2 Operated B
12205	51-2 Operated C
12207	50-2 Starter A
12208	50-2 Starter B
12209	50-2 Starter C
12210	50-2 Operated A
12211	50-2 Operated B
12212	50-2 Operated C
12214	51N-2 Starter
12215	51N-2 Operated
12217	50N-2 Starter
12218	50N-2 Operated
12220	51-1
12221	50-1
12400	50BF-1 ReTrip
12401	50BF-1 BackTrip
12402	50BF-2 ReTrip
12403	50BF-2 BackTrip
12405	59NIT Starter
12406	59NDT Starter
12407	59NIT Operated
12408	59NDT Operated
12410	46IT-1 Starter
12411	46IT-2 Starter
12412	46IT-1 Operated
12413	46IT-2 Operated
12414	46DT-1 Operated
12415	46DT-2 Operated
12416	37-1 Starter
12417	37-2 Starter
12418	37-1 Operated
12419	37-2 Operated
12500	General Alarm 1
12501	General Alarm 2
12502	General Alarm 3
12503	General Alarm 4
12504	General Alarm 5
12505	General Alarm 6
12506	General Alarm 7
12507	General Alarm 8
12508	General Alarm 9
12509	General Alarm 10
12510	General Alarm 11
12511	General Alarm 12
12512	Quick Logic E1
12513	Quick Logic E2
12514	Quick Logic E3
12515	Quick Logic E4
12516	Quick Logic E5
12517	Quick Logic E6
12518	Quick Logic E7
12519	Quick Logic E8
12520	Quick Logic E9
12521	Quick Logic E10
12522	Quick Logic E11
12523	Quick Logic E12
12524	Quick Logic E13
12525	Quick Logic E14
12526	Quick Logic E15
12527	Quick Logic E16
12544	Close Circuit Fail 1
12545	Close Circuit Fail 2
12546	Close Circuit Fail 3

12547	Close Circuit Fail 4
12548	Close Circuit Fail 5
12549	Close Circuit Fail 6
12560	46BC-1
12561	46BC-2
12562	CB1 Total Trip Count
12563	CB1 Delta Trip Count
12565	I ² t CB1 Wear
12566	I ² t CB2 Wear
12567	CB2 Total Trip Count
12568	CB2 Delta Trip Count
12570	81HBL2
12571	81HBL5
12572	37G-1
12573	37G-2
12574	Close CB1
12575	CB1 Fail To Close
12576	CB1 DBI Alarm
12577	Open CB1
12578	CB1 Fail To Open
12579	Close CB2
12580	CB2 Fail To Close
12581	CB2 DBI Alarm
12582	Open CB2
12583	CB2 Fail To Open
12584	CB1 Trip Time Alarm
12585	CB2 Trip Time Alarm
12820	CB1
12821	CB2

Registers

Address	Name	Format	Multiplier	Description
30001	No.of Events In Store	1 Register	0	
30002	Event Record	8 Registers ³	0	
30010	Number of Fault Records	UINT16		
30012	Number of Event Records	UINT16		
30014	Number of Waveform Records	UINT16		
30016	Number of CPU resets	UINT16		
30018	Number of CPU warmstarts	UINT16		
30100	Operate Ia	FP_32BITS_3DP ¹		Ia x Inom
30102	Operate Ib	FP_32BITS_3DP ¹		
30104	Operate Ic	FP_32BITS_3DP ¹		
30106	Restrain Ia	FP_32BITS_3DP ¹		
30108	Restrain Ib	FP_32BITS_3DP ¹		
30110	Restrain Ic	FP_32BITS_3DP ¹		
30112	W1 2 nd Harmonic Ia	FP_32BITS_3DP ¹		
30114	W1 2 nd Harmonic Ib	FP_32BITS_3DP ¹		
30116	W1 2 nd Harmonic Ic	FP_32BITS_3DP ¹		
30118	W2 2 nd Harmonic Ia	FP_32BITS_3DP ¹		
30120	W2 2 nd Harmonic Ib	FP_32BITS_3DP ¹		
30122	W2 2 nd Harmonic Ic	FP_32BITS_3DP ¹		
30200	Primary Ig-1	FP_32BITS_3DP ¹		Ig kA
30202	Secondary Ig-1	FP_32BITS_3DP ¹		Ig A
30204	Nominal Ig-1	FP_32BITS_3DP ¹		Ig x Inom
30206	Primary Ig-2	FP_32BITS_3DP ¹		Ig kA
30208	Secondary Ig-2	FP_32BITS_3DP ¹		Ig A
30210	Nominal Ig-2	FP_32BITS_3DP ¹		Ig x Inom
30400	Primary Voltage kV	FP_32BITS_3DP ¹		kV
30402	Secondary Voltage V	FP_32BITS_3DP ¹		V
30404	Nominal Voltage xVn	FP_32BITS_3DP ¹		X Vnom
30406	Frequency Hz	FP_32BITS_3DP ¹		
30420	CB1 Wear A	FP_32BITS_3DP ¹	0.000001	CB1 Wear A
30421	CB1 Wear B	FP_32BITS_3DP ¹	0.000001	CB1 Wear B
30422	CB1 Wear C	FP_32BITS_3DP ¹	0.000001	CB1 Wear C
30423	CB1 Wear A Remaining	FP_32BITS_3DP ¹		CB1 Wear A Remaining
30424	CB1 Wear B Remaining	FP_32BITS_3DP ¹		CB1 Wear B Remaining
30425	CB1 Wear C Remaining	FP_32BITS_3DP ¹		CB1 Wear C Remaining
30426	CB1 Wear Minimum	FP_32BITS_3DP ¹		CB1 Wear Minimum
30430	CB2 Wear A	FP_32BITS_3DP ¹	0.000001	CB2 Wear A
30431	CB2 Wear B	FP_32BITS_3DP ¹	0.000001	CB2 Wear B
30432	CB2 Wear C	FP_32BITS_3DP ¹	0.000001	CB2 Wear C
30433	CB2 Wear A Remaining	FP_32BITS_3DP ¹		CB2 Wear A Remaining
30434	CB2 Wear B Remaining	FP_32BITS_3DP ¹		CB2 Wear B Remaining
30435	CB2 Wear C Remaining	FP_32BITS_3DP ¹		CB2 Wear C Remaining
30436	CB2 Wear Minimum	FP_32BITS_3DP ¹		CB2 Wear Minimum
30502	V/f Value xVn/fn	FP_32BITS_3DP ¹		
30504	V/f IDMTL Status %	FP_32BITS_3DP ¹		
30602	Thermal Status Ph A	FP_32BITS_3DP ¹		%
30604	Thermal Status Ph B	FP_32BITS_3DP ¹		%
30606	Thermal Status Ph C	FP_32BITS_3DP ¹		%
30610	CB1 Total Trip Count	UINT32		CB1 Total Trip Count
30612	CB1 Delta Trip Count	UINT32		CB1 Delta Trip Count
30614	CB2 Total Trip Count	UINT32		CB2 Total Trip Count
30616	CB2 Delta Trip Count	UINT32		CB2 Delta Trip Count
30700	W1 Ia Last Trip	FP_32BITS_3DP ¹		Ia Fault

Address	Name	Format	Multiplier	Description
30702	W1 Ib Last Trip	FP_32BITS_3DP ¹		Ib Fault
30704	W1 Ic Last Trip	FP_32BITS_3DP ¹		Ic Fault
30706	W2 Ia Last Trip	FP_32BITS_3DP ¹		Ia Fault
30708	W2 Ib Last Trip	FP_32BITS_3DP ¹		Ib Fault
30710	W2 Ic Last Trip	FP_32BITS_3DP ¹		Ic Fault
30714	Ig-1 Last Trip	FP_32BITS_3DP ¹		In Fault
30716	Ig-2 Last Trip	FP_32BITS_3DP ¹		In Fault
31100	W1 Primary Ia	FP_32BITS_3DP ¹		A
31102	W1 Primary Ib	FP_32BITS_3DP ¹		A
31104	W1 Primary Ic	FP_32BITS_3DP ¹		A
31106	W1 Secondary Ia	FP_32BITS_3DP ¹		A
31108	W1 Secondary Ib	FP_32BITS_3DP ¹		A
31110	W1 Secondary Ic	FP_32BITS_3DP ¹		A
31112	W1 Nominal Ia	FP_32BITS_3DP ¹		x Inom
31114	W1 Nominal Ib	FP_32BITS_3DP ¹		x Inom
31116	W1 Nominal Ic	FP_32BITS_3DP ¹		x Inom
31118	W1 Line Ia	FP_32BITS_3DP ¹		kA
31120	W1 Line Ib	FP_32BITS_3DP ¹		kA
31122	W1 Line Ic	FP_32BITS_3DP ¹		kA
31124	W1 Relay Ia	FP_32BITS_3DP ¹		x Inom
31126	W1 Relay Ib	FP_32BITS_3DP ¹		x Inom
31128	W1 Relay Ic	FP_32BITS_3DP ¹		x Inom
31200	W2 Primary Ia	FP_32BITS_3DP ¹		A
31202	W2 Primary Ib	FP_32BITS_3DP ¹		A
31204	W2 Primary Ic	FP_32BITS_3DP ¹		A
31206	W2 Secondary Ia	FP_32BITS_3DP ¹		A
31208	W2 Secondary Ib	FP_32BITS_3DP ¹		A
31210	W2 Secondary Ic	FP_32BITS_3DP ¹		A
31212	W2 Nominal Ia	FP_32BITS_3DP ¹		x Inom
31214	W2 Nominal Ib	FP_32BITS_3DP ¹		x Inom
31216	W2 Nominal Ic	FP_32BITS_3DP ¹		x Inom
31218	W2 Line Ia	FP_32BITS_3DP ¹		kA
31220	W2 Line Ib	FP_32BITS_3DP ¹		kA
31222	W2 Line Ic	FP_32BITS_3DP ¹		kA
31224	W2 Relay Ia	FP_32BITS_3DP ¹		x Inom
31226	W2 Relay Ib	FP_32BITS_3DP ¹		x Inom
31228	W2 Relay Ic	FP_32BITS_3DP ¹		x Inom
31300	W3 Primary Ia	FP_32BITS_3DP		W3 Ia kA
31302	W3 Primary Ib	FP_32BITS_3DP		W3 Ib kA
31304	W3 Primary Ic	FP_32BITS_3DP		W3 Ic kA
31306	W3 Secondary Ia	FP_32BITS_3DP		W3 Ia A
31308	W3 Secondary Ib	FP_32BITS_3DP		W3 Ib A
31310	W3 Secondary Ic	FP_32BITS_3DP		W3 Ic A
31312	W3 Nominal Ia	FP_32BITS_3DP		W3 Ia xIn
31314	W3 Nominal Ib	FP_32BITS_3DP		W3 Ib xIn
31316	W3 Nominal Ic	FP_32BITS_3DP		W3 Ic xIn
31318	W3 Line Ia	FP_32BITS_3DP		W3 Line Ia xIn
31320	W3 Line Ib	FP_32BITS_3DP		W3 Line Ib xIn
31322	W3 Line Ic	FP_32BITS_3DP		W3 Line Ic xIn
31324	W3 Relay Ia	FP_32BITS_3DP		W3 Relay Ia xIn
31326	W3 Relay Ib	FP_32BITS_3DP		W3 Relay Ib xIn
31328	W3 Relay Ic	FP_32BITS_3DP		W3 Relay Ic xIn
32400	W1 I Phase A Max	FP_32BITS_3DP		Max Current W1 Ia
32402	W1 I Phase B Max	FP_32BITS_3DP		Max Current W1 Ib
32404	W1 I Phase C Max	FP_32BITS_3DP		Max Current W1 Ic
32406	W2 I Phase A Max	FP_32BITS_3DP		Max Current W2 Ia
32408	W2 I Phase B Max	FP_32BITS_3DP		Max Current W2 Ib
32410	W2 I Phase C Max	FP_32BITS_3DP		Max Current W2 Ic
32412	W3 I Phase A Max	FP_32BITS_3DP		W3 Max Current Ia
32414	W3 I Phase B Max	FP_32BITS_3DP		W3 Max Current Ib
32416	W3 I Phase C Max	FP_32BITS_3DP		W3 Max Current Ic

- 1) FP_32BITS_3DP: 2 registers - 32 bit fixed point, a 32 bit integer containing a value to 3 decimal places e.g. 50000 sent = 50.000
- 2) UINT16: 1 register - standard 16 bit unsigned integer
- 3) Sequence of 8 registers containing an event record. Read address 30002 for 8 registers (16 bytes), each read returns the earliest event record and removes it from the internal store. Repeat this process for the number of events in the register 30001, or until no more events are returned. (the error condition exception code 2)

Holding Registers (Read Write values)

Address	Description
40001	Time Meter

Event Format

The format of the event record is defined by the zero byte. It signifies the type of record which is used to decode the event information. The zero byte can be one of the following.

Type	Description
1	Event
2	Event with Relative Time
4	Measurand Event with Relative Time

Section 5: DNP3.0 Definitions

5.1 Device Profile

The following table provides a “Device Profile Document” in the standard format defined in the DNP 3.0 Subset Definitions Document. While it is referred to in the DNP 3.0 Subset Definitions as a “Document,” it is in fact a table, and only a component of a total interoperability guide. The table, in combination with the Implementation Table provided in Section 5.2 (beginning on page 34), and the Point List Tables provided in Section 5.3 (beginning on page 44), should provide a complete configuration/interoperability guide for communicating with a device implementing the Triangle MicroWorks, Inc. DNP 3.0 Slave Source Code Library.

DNP V3.0 DEVICE PROFILE DOCUMENT (Also see the DNP 3.0 Implementation Table in Section 5.2, beginning on page 34.)	
Vendor Name: Siemens Protection Devices Ltd.	
Device Name: 7SR242, using the Triangle MicroWorks, Inc. DNP3 Slave Source Code Library, Version 3.	
Highest DNP Level Supported: For Requests: Level 3 For Responses: Level 3	Device Function: <input type="checkbox"/> Master <input checked="" type="checkbox"/> Slave
Notable objects, functions, and/or qualifiers supported in addition to the Highest DNP Levels Supported (the complete list is described in the attached table): For static (non-change-event) object requests, request qualifier codes 07 and 08 (limited quantity), and 17 and 28 (index) are supported. Static object requests sent with qualifiers 07, or 08, will be responded with qualifiers 00 or 01. Output Event Object 11 is supported.	
Maximum Data Link Frame Size (octets): Transmitted: 256 Received 256	Maximum Application Fragment Size (octets): Transmitted: 2048 Received 2048
Maximum Data Link Re-tries: <input type="checkbox"/> None <input checked="" type="checkbox"/> Fixed (3) <input type="checkbox"/> Configurable from 0 to 65535	Maximum Application Layer Re-tries: <input checked="" type="checkbox"/> None <input type="checkbox"/> Configurable
Requires Data Link Layer Confirmation: <input checked="" type="checkbox"/> Never <input type="checkbox"/> Always <input type="checkbox"/> Sometimes <input type="checkbox"/> Configurable as: Never, Only for multi-frame messages, or Always	
Requires Application Layer Confirmation: <input type="checkbox"/> Never <input type="checkbox"/> Always <input checked="" type="checkbox"/> When reporting Event Data (Slave devices only) <input checked="" type="checkbox"/> When sending multi-fragment responses (Slave devices only) <input type="checkbox"/> Sometimes <input type="checkbox"/> Configurable as: “Only when reporting event data”, or “When reporting event data or multi-fragment messages.”	

DNP V3.0 DEVICE PROFILE DOCUMENT (Also see the DNP 3.0 Implementation Table in Section 5.2, beginning on page 34.)																																																								
Timeouts while waiting for: <table style="width: 100%; border: none;"> <tr> <td>Data Link Confirm:</td> <td><input type="checkbox"/> None</td> <td><input checked="" type="checkbox"/> Fixed - 2sec</td> <td><input type="checkbox"/> Variable</td> <td><input type="checkbox"/> Configurable.</td> </tr> <tr> <td>Complete Appl. Fragment:</td> <td><input checked="" type="checkbox"/> None</td> <td><input type="checkbox"/> Fixed at _____</td> <td><input type="checkbox"/> Variable</td> <td><input type="checkbox"/> Configurable</td> </tr> <tr> <td>Application Confirm:</td> <td><input type="checkbox"/> None</td> <td><input checked="" type="checkbox"/> Fixed - 10sec</td> <td><input type="checkbox"/> Variable</td> <td><input type="checkbox"/> Configurable.</td> </tr> <tr> <td>Complete Appl. Response:</td> <td><input checked="" type="checkbox"/> None</td> <td><input type="checkbox"/> Fixed at _____</td> <td><input type="checkbox"/> Variable</td> <td><input type="checkbox"/> Configurable</td> </tr> </table> <p>Others: Transmission Delay, (0 sec) Select/Operate Arm Timeout, (5 sec) Need Time Interval, (30 minutes) Application File Timeout, (60 sec) Unsolicited Notification Delay, (5 seconds) Unsolicited Response Retry Delay, (between 3 – 9 seconds) Unsolicited Offline Interval, (30 seconds) Binary Change Event Scan Period, (Polled, Not Applicable) Double Bit Change Event Scan Period, (Unsupported - Not Applicable) Analog Change Event Scan Period, (Unsupported - Not Applicable) Counter Change Event Scan Period, (Unsupported - Not Applicable) Frozen Counter Change Event Scan Period, (Unsupported - Not Applicable) String Change Event Scan Period, (Unsupported - Not Applicable) Virtual Terminal Event Scan Period, (Unsupported - Not Applicable)</p>		Data Link Confirm:	<input type="checkbox"/> None	<input checked="" type="checkbox"/> Fixed - 2sec	<input type="checkbox"/> Variable	<input type="checkbox"/> Configurable.	Complete Appl. Fragment:	<input checked="" type="checkbox"/> None	<input type="checkbox"/> Fixed at _____	<input type="checkbox"/> Variable	<input type="checkbox"/> Configurable	Application Confirm:	<input type="checkbox"/> None	<input checked="" type="checkbox"/> Fixed - 10sec	<input type="checkbox"/> Variable	<input type="checkbox"/> Configurable.	Complete Appl. Response:	<input checked="" type="checkbox"/> None	<input type="checkbox"/> Fixed at _____	<input type="checkbox"/> Variable	<input type="checkbox"/> Configurable																																			
Data Link Confirm:	<input type="checkbox"/> None	<input checked="" type="checkbox"/> Fixed - 2sec	<input type="checkbox"/> Variable	<input type="checkbox"/> Configurable.																																																				
Complete Appl. Fragment:	<input checked="" type="checkbox"/> None	<input type="checkbox"/> Fixed at _____	<input type="checkbox"/> Variable	<input type="checkbox"/> Configurable																																																				
Application Confirm:	<input type="checkbox"/> None	<input checked="" type="checkbox"/> Fixed - 10sec	<input type="checkbox"/> Variable	<input type="checkbox"/> Configurable.																																																				
Complete Appl. Response:	<input checked="" type="checkbox"/> None	<input type="checkbox"/> Fixed at _____	<input type="checkbox"/> Variable	<input type="checkbox"/> Configurable																																																				
Sends/Executes Control Operations: <table style="width: 100%; border: none;"> <tr> <td>WRITE Binary Outputs</td> <td><input checked="" type="checkbox"/> Never</td> <td><input type="checkbox"/> Always</td> <td><input type="checkbox"/> Sometimes</td> <td><input type="checkbox"/> Configurable</td> </tr> <tr> <td>SELECT/OPERATE</td> <td><input type="checkbox"/> Never</td> <td><input checked="" type="checkbox"/> Always</td> <td><input type="checkbox"/> Sometimes</td> <td><input type="checkbox"/> Configurable</td> </tr> <tr> <td>DIRECT OPERATE</td> <td><input type="checkbox"/> Never</td> <td><input checked="" type="checkbox"/> Always</td> <td><input type="checkbox"/> Sometimes</td> <td><input type="checkbox"/> Configurable</td> </tr> <tr> <td>DIRECT OPERATE – NO ACK <input type="checkbox"/></td> <td>Never</td> <td><input checked="" type="checkbox"/> Always</td> <td><input type="checkbox"/> Sometimes</td> <td><input type="checkbox"/> Configurable</td> </tr> <tr> <td>Count > 1</td> <td><input checked="" type="checkbox"/> Never</td> <td><input type="checkbox"/> Always</td> <td><input type="checkbox"/> Sometimes</td> <td><input type="checkbox"/> Configurable</td> </tr> <tr> <td>Pulse On</td> <td><input type="checkbox"/> Never</td> <td><input type="checkbox"/> Always</td> <td><input checked="" type="checkbox"/> Sometimes</td> <td><input type="checkbox"/> Configurable</td> </tr> <tr> <td>Pulse Off</td> <td><input type="checkbox"/> Never</td> <td><input type="checkbox"/> Always</td> <td><input checked="" type="checkbox"/> Sometimes</td> <td><input type="checkbox"/> Configurable</td> </tr> <tr> <td>Latch On</td> <td><input type="checkbox"/> Never</td> <td><input type="checkbox"/> Always</td> <td><input checked="" type="checkbox"/> Sometimes</td> <td><input type="checkbox"/> Configurable</td> </tr> <tr> <td>Latch Off</td> <td><input type="checkbox"/> Never</td> <td><input type="checkbox"/> Always</td> <td><input checked="" type="checkbox"/> Sometimes</td> <td><input type="checkbox"/> Configurable</td> </tr> <tr> <td>Queue</td> <td><input checked="" type="checkbox"/> Never</td> <td><input type="checkbox"/> Always</td> <td><input type="checkbox"/> Sometimes</td> <td><input type="checkbox"/> Configurable</td> </tr> <tr> <td>Clear Queue</td> <td><input checked="" type="checkbox"/> Never</td> <td><input type="checkbox"/> Always</td> <td><input type="checkbox"/> Sometimes</td> <td><input type="checkbox"/> Configurable</td> </tr> </table>		WRITE Binary Outputs	<input checked="" type="checkbox"/> Never	<input type="checkbox"/> Always	<input type="checkbox"/> Sometimes	<input type="checkbox"/> Configurable	SELECT/OPERATE	<input type="checkbox"/> Never	<input checked="" type="checkbox"/> Always	<input type="checkbox"/> Sometimes	<input type="checkbox"/> Configurable	DIRECT OPERATE	<input type="checkbox"/> Never	<input checked="" type="checkbox"/> Always	<input type="checkbox"/> Sometimes	<input type="checkbox"/> Configurable	DIRECT OPERATE – NO ACK <input type="checkbox"/>	Never	<input checked="" type="checkbox"/> Always	<input type="checkbox"/> Sometimes	<input type="checkbox"/> Configurable	Count > 1	<input checked="" type="checkbox"/> Never	<input type="checkbox"/> Always	<input type="checkbox"/> Sometimes	<input type="checkbox"/> Configurable	Pulse On	<input type="checkbox"/> Never	<input type="checkbox"/> Always	<input checked="" type="checkbox"/> Sometimes	<input type="checkbox"/> Configurable	Pulse Off	<input type="checkbox"/> Never	<input type="checkbox"/> Always	<input checked="" type="checkbox"/> Sometimes	<input type="checkbox"/> Configurable	Latch On	<input type="checkbox"/> Never	<input type="checkbox"/> Always	<input checked="" type="checkbox"/> Sometimes	<input type="checkbox"/> Configurable	Latch Off	<input type="checkbox"/> Never	<input type="checkbox"/> Always	<input checked="" type="checkbox"/> Sometimes	<input type="checkbox"/> Configurable	Queue	<input checked="" type="checkbox"/> Never	<input type="checkbox"/> Always	<input type="checkbox"/> Sometimes	<input type="checkbox"/> Configurable	Clear Queue	<input checked="" type="checkbox"/> Never	<input type="checkbox"/> Always	<input type="checkbox"/> Sometimes	<input type="checkbox"/> Configurable
WRITE Binary Outputs	<input checked="" type="checkbox"/> Never	<input type="checkbox"/> Always	<input type="checkbox"/> Sometimes	<input type="checkbox"/> Configurable																																																				
SELECT/OPERATE	<input type="checkbox"/> Never	<input checked="" type="checkbox"/> Always	<input type="checkbox"/> Sometimes	<input type="checkbox"/> Configurable																																																				
DIRECT OPERATE	<input type="checkbox"/> Never	<input checked="" type="checkbox"/> Always	<input type="checkbox"/> Sometimes	<input type="checkbox"/> Configurable																																																				
DIRECT OPERATE – NO ACK <input type="checkbox"/>	Never	<input checked="" type="checkbox"/> Always	<input type="checkbox"/> Sometimes	<input type="checkbox"/> Configurable																																																				
Count > 1	<input checked="" type="checkbox"/> Never	<input type="checkbox"/> Always	<input type="checkbox"/> Sometimes	<input type="checkbox"/> Configurable																																																				
Pulse On	<input type="checkbox"/> Never	<input type="checkbox"/> Always	<input checked="" type="checkbox"/> Sometimes	<input type="checkbox"/> Configurable																																																				
Pulse Off	<input type="checkbox"/> Never	<input type="checkbox"/> Always	<input checked="" type="checkbox"/> Sometimes	<input type="checkbox"/> Configurable																																																				
Latch On	<input type="checkbox"/> Never	<input type="checkbox"/> Always	<input checked="" type="checkbox"/> Sometimes	<input type="checkbox"/> Configurable																																																				
Latch Off	<input type="checkbox"/> Never	<input type="checkbox"/> Always	<input checked="" type="checkbox"/> Sometimes	<input type="checkbox"/> Configurable																																																				
Queue	<input checked="" type="checkbox"/> Never	<input type="checkbox"/> Always	<input type="checkbox"/> Sometimes	<input type="checkbox"/> Configurable																																																				
Clear Queue	<input checked="" type="checkbox"/> Never	<input type="checkbox"/> Always	<input type="checkbox"/> Sometimes	<input type="checkbox"/> Configurable																																																				
Attach explanation if 'Sometimes' or 'Configurable' was checked for any operation.																																																								
Reports Binary Input Change Events when no specific variation requested: <table style="width: 100%; border: none;"> <tr> <td><input type="checkbox"/> Never</td> </tr> <tr> <td><input type="checkbox"/> Only time-tagged</td> </tr> <tr> <td><input type="checkbox"/> Only non-time-tagged</td> </tr> <tr> <td><input checked="" type="checkbox"/> Configurable to send one or the other</td> </tr> </table>	<input type="checkbox"/> Never	<input type="checkbox"/> Only time-tagged	<input type="checkbox"/> Only non-time-tagged	<input checked="" type="checkbox"/> Configurable to send one or the other	Reports time-tagged Binary Input Change Events when no specific variation requested: <table style="width: 100%; border: none;"> <tr> <td><input type="checkbox"/> Never</td> </tr> <tr> <td><input type="checkbox"/> Binary Input Change With Time</td> </tr> <tr> <td><input type="checkbox"/> Binary Input Change With Relative Time</td> </tr> <tr> <td><input checked="" type="checkbox"/> Configurable</td> </tr> </table>	<input type="checkbox"/> Never	<input type="checkbox"/> Binary Input Change With Time	<input type="checkbox"/> Binary Input Change With Relative Time	<input checked="" type="checkbox"/> Configurable																																															
<input type="checkbox"/> Never																																																								
<input type="checkbox"/> Only time-tagged																																																								
<input type="checkbox"/> Only non-time-tagged																																																								
<input checked="" type="checkbox"/> Configurable to send one or the other																																																								
<input type="checkbox"/> Never																																																								
<input type="checkbox"/> Binary Input Change With Time																																																								
<input type="checkbox"/> Binary Input Change With Relative Time																																																								
<input checked="" type="checkbox"/> Configurable																																																								
Sends Unsolicited Responses: <table style="width: 100%; border: none;"> <tr> <td><input type="checkbox"/> Never</td> </tr> <tr> <td><input checked="" type="checkbox"/> Configurable</td> </tr> <tr> <td><input type="checkbox"/> Only certain objects</td> </tr> <tr> <td><input type="checkbox"/> Sometimes (attach explanation)</td> </tr> <tr> <td><input checked="" type="checkbox"/> ENABLE/DISABLE UNSOLICITED Function codes supported</td> </tr> </table>	<input type="checkbox"/> Never	<input checked="" type="checkbox"/> Configurable	<input type="checkbox"/> Only certain objects	<input type="checkbox"/> Sometimes (attach explanation)	<input checked="" type="checkbox"/> ENABLE/DISABLE UNSOLICITED Function codes supported	Sends Static Data in Unsolicited Responses: <table style="width: 100%; border: none;"> <tr> <td><input checked="" type="checkbox"/> Never</td> </tr> <tr> <td><input type="checkbox"/> When Device Restarts</td> </tr> <tr> <td><input type="checkbox"/> When Status Flags Change</td> </tr> </table> No other options are permitted.	<input checked="" type="checkbox"/> Never	<input type="checkbox"/> When Device Restarts	<input type="checkbox"/> When Status Flags Change																																															
<input type="checkbox"/> Never																																																								
<input checked="" type="checkbox"/> Configurable																																																								
<input type="checkbox"/> Only certain objects																																																								
<input type="checkbox"/> Sometimes (attach explanation)																																																								
<input checked="" type="checkbox"/> ENABLE/DISABLE UNSOLICITED Function codes supported																																																								
<input checked="" type="checkbox"/> Never																																																								
<input type="checkbox"/> When Device Restarts																																																								
<input type="checkbox"/> When Status Flags Change																																																								
Default Counter Object/Variation: <table style="width: 100%; border: none;"> <tr> <td><input checked="" type="checkbox"/> No Counters Reported</td> </tr> <tr> <td><input type="checkbox"/> Configurable</td> </tr> <tr> <td><input type="checkbox"/> Default Object</td> </tr> <tr> <td> Default Variation:</td> </tr> <tr> <td><input type="checkbox"/> Point-by-point list attached</td> </tr> </table>	<input checked="" type="checkbox"/> No Counters Reported	<input type="checkbox"/> Configurable	<input type="checkbox"/> Default Object	Default Variation:	<input type="checkbox"/> Point-by-point list attached	Counters Roll Over at: <table style="width: 100%; border: none;"> <tr> <td><input checked="" type="checkbox"/> No Counters Reported</td> </tr> <tr> <td><input type="checkbox"/> Configurable (attach explanation)</td> </tr> <tr> <td><input type="checkbox"/> 16 Bits</td> </tr> <tr> <td><input type="checkbox"/> 32 Bits</td> </tr> <tr> <td><input type="checkbox"/> Other Value: _____</td> </tr> <tr> <td><input type="checkbox"/> Point-by-point list attached</td> </tr> </table>	<input checked="" type="checkbox"/> No Counters Reported	<input type="checkbox"/> Configurable (attach explanation)	<input type="checkbox"/> 16 Bits	<input type="checkbox"/> 32 Bits	<input type="checkbox"/> Other Value: _____	<input type="checkbox"/> Point-by-point list attached																																												
<input checked="" type="checkbox"/> No Counters Reported																																																								
<input type="checkbox"/> Configurable																																																								
<input type="checkbox"/> Default Object																																																								
Default Variation:																																																								
<input type="checkbox"/> Point-by-point list attached																																																								
<input checked="" type="checkbox"/> No Counters Reported																																																								
<input type="checkbox"/> Configurable (attach explanation)																																																								
<input type="checkbox"/> 16 Bits																																																								
<input type="checkbox"/> 32 Bits																																																								
<input type="checkbox"/> Other Value: _____																																																								
<input type="checkbox"/> Point-by-point list attached																																																								

DNP V3.0 DEVICE PROFILE DOCUMENT (Also see the DNP 3.0 Implementation Table in Section 5.2, beginning on page 34.)		
Sends Multi-Fragment Responses:		
<input checked="" type="checkbox"/>	Yes	
<input type="checkbox"/>	No	
<input type="checkbox"/>	Configurable	
Sequential File Transfer Support:		
File Transfer Support	<input type="checkbox"/> Yes	<input checked="" type="checkbox"/> No
Append File Mode	<input type="checkbox"/> Yes	<input checked="" type="checkbox"/> No
Custom Status Code Strings	<input type="checkbox"/> Yes	<input checked="" type="checkbox"/> No
Permissions Field	<input type="checkbox"/> Yes	<input checked="" type="checkbox"/> No
File Events Assigned to Class	<input type="checkbox"/> Yes	<input checked="" type="checkbox"/> No
File Events Send Immediately	<input type="checkbox"/> Yes	<input checked="" type="checkbox"/> No
Multiple Blocks in a Fragment	<input type="checkbox"/> Yes	<input checked="" type="checkbox"/> No
Max Number of Files Open	0	

5.2 Implementation Table

The following table identifies which object variations, function codes, and qualifiers the Triangle MicroWorks, Inc. DNP 3.0 Slave Source Code Library supports in both request messages and in response messages. For static (non-change-event) objects, requests sent with qualifiers 00, 01, 06, 07, or 08, will be responded with qualifiers 00 or 01. Requests sent with qualifiers 17 or 28 will be responded with qualifiers 17 or 28. For change-event objects, qualifiers 17 or 28 are always responded.

In the table below, text shaded as **00, 01 (start stop)** indicates Subset Level 3 functionality (beyond Subset Level 2).

In the table below, text shaded as **07, 08 (limited qty)** indicates functionality beyond Subset Level 3.

OBJECT			REQUEST (Library will parse)		RESPONSE (Library will respond with)	
Object Number	Variation Number	Description	Function Codes (dec)	Qualifier Codes (hex)	Function Codes (dec)	Qualifier Codes (hex)
1	0	Binary Input – Any Variation	1 (read) 22 (assign class)	00, 01 (start-stop) 06(no range, or all) 07, 08(limited qty) 17, 27, 28(index)		
1	1 (default – see note 1)	Binary Input	1 (read)	00, 01 (start-stop) 06(no range, or all) 07, 08(limited qty) 17, 27, 28(index)	129 (response)	00, 01(start-st 17, 28(index – see note 2)
1	2	Binary Input with Status	1 (read)	00, 01 (start-stop) 06(no range, or all) 07, 08(limited qty) 17, 27, 28(index)	129 (response)	00, 01(start-st 17, 28(index – see note 2)
2	0	Binary Input Change – Any Variation	1 (read)	06(no range, or all) 07, 08(limited qty)		
2	1	Binary Input Change without Time	1 (read)	06(no range, or all) 07, 08(limited qty)	129 (response) 130 (unsol. resp)	17, 28 (index)
2	2	Binary Input Change with Time	1 (read)	06(no range, or all) 07, 08(limited qty)	129 (response) 130 (unsol. resp)	17, 28 (index)
2	3 (default – see note 1)	Binary Input Change with Relative Time	1 (read)	06(no range, or all) 07, 08(limited qty)	129 (response) 130 (unsol. resp)	17, 28 (index)
3	0	Double Bit Input – Any Variation	1 (read) 22 (assign class)	00, 01 (start-stop) 06 (no range, or all) 07, 08 (limited qty) 17, 27, 28 (index)		

OBJECT			REQUEST (Library will parse)		RESPONSE (Library will respond with)	
Object Number	Variation Number	Description	Function Codes (dec)	Qualifier Codes (hex)	Function Codes (dec)	Qualifier Codes (hex)
3	1 (default – see note 1)	Double Bit Input	1 (read)	00, 01 (start-stop) 06 (no range, or all) 07, 08 (limited qty) 17, 27, 28 (index)	129 (response)	00, 01 (start-stop) 17, 28 (index – see note 1)
3	2	Double Bit Input with Status	1 (read)	00, 01 (start-stop) 06 (no range, or all) 07, 08 (limited qty) 17, 27, 28 (index)	129 (response)	00, 01 (start-stop) 17, 28 (index – see note 1)
4	0	Double Bit Input Change – Any Variation	1 (read)	06 (no range, or all) 07, 08 (limited qty)		
4	1	Double Bit Input Change without Time	1 (read)	06 (no range, or all) 07, 08 (limited qty)	129 (response) 130 (unsol. resp)	17, 28 (index)
4	2	Double Bit Input Change with Time	1 (read)	06 (no range, or all) 07, 08 (limited qty)	129 (response) 130 (unsol. resp)	17, 28 (index)
4	3 (default – see note 1)	Double Bit Input Change with Relative Time	1 (read)	06 (no range, or all) 07, 08 (limited qty)	129 (response) 130 (unsol. resp)	17, 28 (index)
10	0	Binary Output – Any Variation	1 (read) 22 (assign class)	00, 01 (start-stop) 06 (no range, or all) 07, 08 (limited qty) 17, 27, 28 (index)		
10	1	Binary Output	1 (read)	00, 01 (start-stop) 06 (no range, or all) 07, 08 (limited qty) 17, 27, 28 (index)	129 (response)	00, 01 (start-stop) 17, 28 (index – see note 1)
			1 (write)	00, 01 (start-stop)		
10	2 (default – see note 1)	Binary Output Status	1 (read)	00, 01 (start-stop) 06 (no range, or all) 07, 08 (limited qty) 17, 27, 28 (index)	129 (response)	00, 01 (start-stop) 17, 28 (index – see note 2)
11	0	Binary Output Change – Any Variation	1 (read)	06 (no range, or all) 07, 08 (limited qty)		
11	1 (default – see note 1)	Binary Output Change without Time	1 (read)	06 (no range, or all) 07, 08 (limited qty)	129 (response) 130 (unsol. resp)	17, 28 (index)

OBJECT			REQUEST (Library will parse)		RESPONSE (Library will respond with)	
Object Number	Variation Number	Description	Function Codes (dec)	Qualifier Codes (hex)	Function Codes (dec)	Qualifier Codes (hex)
11	2	Binary Output Change with Time	1 (read)	06(no range, or all) 07, 08(limited qty)	129 (response) 130 (unsol. resp)	17, 28(index)
12	0	Control Relay Output Block	22 (assign class)	00, 01(start-stop) 06(no range, or all) 07, 08(limited qty) 17, 27, 28(index)		
12	1	Control Relay Output Block	3 (select) 4 (operate) 5 (direct op) 6(dir. op, noack)	17, 28 (index)	129 (response)	echo of request
12	2	Pattern Control Block	3 (select) 4 (operate) 5 (direct op) 6(dir. op, noack)	7(limited quantity)	129 (response)	echo of request
12	3	Pattern Mask	3 (select) 4 (operate) 5 (direct op) 6(dir. op, noack)	00, 01(start-stop)	129 (response)	echo of request
13	0	Binary Output Command Event – Any Variation	1 (read)	06 (no range, or all) 07, 08 (limited qty)		
13	1	Binary Output Command Event without Time	1 (read)	06 (no range, or all) 07, 08 (limited qty)	129 (response) 130 (unsol. resp)	17, 28 (index)
13	2	Binary Output Command Event with Time	1 (read)	06 (no range, or all) 07, 08 (limited qty)	129 (response) 130 (unsol. resp)	17, 28 (index)
20	0	Binary Input – Any Variation	1 (read) 22 (assign class)	00, 01 (start-stop) 06 (no range, or all) 07, 08 (limited qty) 17, 27, 28 (index)		
			7 (freeze) 8 (freeze noack) 9 (freeze clear) 10 (frz. cl. noack)	00, 01 (start-stop) 06 (no range, or all) 07, 08 (limited qty)		
20	1	32-Bit Binary Counter (with Flag)	1 (read)	00, 01 (start-stop) 06 (no range, or all) 07, 08 (limited qty) 17, 27, 28 (index)	129 (response)	00, 01 (start-stop) 17, 28 (index – see note 2)

OBJECT			REQUEST (Library will parse)		RESPONSE (Library will respond with)	
Object Number	Variation Number	Description	Function Codes (dec)	Qualifier Codes (hex)	Function Codes (dec)	Qualifier Codes (hex)
20	2	16-Bit Binary Counter (with Flag)	1 (read)	00, 01 (start-stop) 06 (no range, or all) 07, 08 (limited qty) 17, 27, 28 (index)	129 (response)	00, 01 (start-stop) 17, 28 (index – see note 2)
20	3	32-Bit Delta Counter (with Flag)				
20	4	16-Bit Delta Counter (with Flag)				
20	5 (default – see note 1)	32-Bit Binary Counter without Flag	1 (read)	00, 01 (start-stop) 06 (no range, or all) 07, 08 (limited qty) 17, 27, 28 (index)	129 (response)	00, 01 (start-stop) 17, 28 (index – see note 2)
20	6	16-Bit Binary Counter without Flag	1 (read)	00, 01 (start-stop) 06 (no range, or all) 07, 08 (limited qty) 17, 27, 28 (index)	129 (response)	00, 01 (start-stop) 17, 28 (index – see note 2)
20	7	32-Bit Delta Counter without Flag				
20	8	16-Bit Delta Counter without Flag				
21	0	Frozen Counter – Any Variation	1 (read) 22 (assign class)	00, 01 (start-stop) 06 (no range, or all) 07, 08 (limited qty) 17, 27, 28 (index)		
21	1	32-Bit Frozen Counter (with Flag)	1 (read)	00, 01 (start-stop) 06 (no range, or all) 07, 08 (limited qty) 17, 27, 28 (index)	129 (response)	00, 01 (start-stop) 17, 28 (index – see note 2)
21	2	16-Bit Frozen Counter (with Flag)	1 (read)	00, 01 (start-stop) 06 (no range, or all) 07, 08 (limited qty) 17, 27, 28 (index)	129 (response)	00, 01 (start-stop) 17, 28 (index – see note 2)
21	3	32-Bit Frozen Delta Counter (with Flag)				
21	4	16-Bit Frozen Delta Counter (with Flag)				

OBJECT			REQUEST (Library will parse)		RESPONSE (Library will respond with)	
Object Number	Variation Number	Description	Function Codes (dec)	Qualifier Codes (hex)	Function Codes (dec)	Qualifier Codes (hex)
21	5	32-Bit Frozen Counter with Time Of Freeze	1 (read)	00, 01 (start-stop) 06 (no range, or all) 07, 08 (limited qty) 17, 27, 28 (index)	129 (response)	00, 01 (start-stop) 17, 28 (index – see note 1)
21	6	16-Bit Frozen Counter with Time Of Freeze	1 (read)	00, 01 (start-stop) 06 (no range, or all) 07, 08 (limited qty) 17, 27, 28 (index)	129 (response)	00, 01 (start-stop) 17, 28 (index – see note 1)
21	7	32-Bit Frozen Delta Counter with Time Of Freeze				
21	8	16-Bit Frozen Delta Counter with Time Of Freeze				
21	9 (default – see note 1)	32-Bit Frozen Counter without Flag	1 (read)	00, 01 (start-stop) 06 (no range, or all) 07, 08 (limited qty) 17, 27, 28 (index)	129 (response)	00, 01 (start-stop) 17, 28 (index – see note 2)
21	10	16-Bit Frozen Counter without Flag	1 (read)	00, 01 (start-stop) 06 (no range, or all) 07, 08 (limited qty) 17, 27, 28 (index)	129 (response)	00, 01 (start-stop) 17, 28 (index – see note 2)
21	11	32-Bit Frozen Delta Counter without Flag				
21	12	16-Bit Frozen Delta Counter without Flag				
22	0	Counter Change Event – Any Variation	1 (read)	06 (no range, or all) 07, 08 (limited qty)		
22	1 (default – see note 1)	32-Bit Counter Change Event without Time	1 (read)	06 (no range, or all) 07, 08 (limited qty)	129 (response) 130 (unsol. resp)	17, 28 (index)
22	2	16-Bit Counter Change Event without Time	1 (read)	06 (no range, or all) 07, 08 (limited qty)	129 (response) 130 (unsol. resp)	17, 28 (index)
22	3	32-Bit Delta Counter Change Event without Time				
22	4	16-Bit Delta Counter Change Event without Time				
22	5	32-Bit Counter Change Event with Time	1 (read)	06 (no range, or all) 07, 08 (limited qty)	129 (response) 130 (unsol. resp)	17, 28 (index)
22	6	16-Bit Counter Change Event with Time	1 (read)	06 (no range, or all) 07, 08 (limited qty)	129 (response) 130 (unsol. resp)	17, 28 (index)

OBJECT			REQUEST (Library will parse)		RESPONSE (Library will respond with)	
Object Number	Variation Number	Description	Function Codes (dec)	Qualifier Codes (hex)	Function Codes (dec)	Qualifier Codes (hex)
22	7	32-Bit Delta Counter Change Event with Time				
22	8	16-Bit Delta Counter Change Event with Time				
23	0	Frozen Counter Event (Variation 0 is used to request default variation)	1 (read)	06 (no range, or all) 07, 08 (limited qty)		
23	1 (default – see note 1)	32-Bit Frozen Counter Event	1 (read)	06 (no range, or all) 07, 08 (limited qty)	129 (response) 130 (unsol. resp)	17, 28 (index)
23	2	16-Bit Frozen Counter Event	1 (read)	06 (no range, or all) 07, 08 (limited qty)	129 (response) 130 (unsol. resp)	17, 28 (index)
23	3	32-Bit Frozen Delta Counter Event				
23	4	16-Bit Frozen Delta Counter Event				
23	5	32-Bit Frozen Counter Event with Time	1 (read)	06 (no range, or all) 07, 08 (limited qty)	129 (response) 130 (unsol. resp)	17, 28 (index)
23	6	16-Bit Frozen Counter Event with Time	1 (read)	06 (no range, or all) 07, 08 (limited qty)	129 (response) 130 (unsol. resp)	17, 28 (index)
23	7	32-Bit Frozen Delta Counter Event with Time				
23	8	16-Bit Frozen Delta Counter Event with Time				
30	0	Analog Input - Any Variation	1 (read) 22(assign class)	00, 01(start-stop) 06(no range, or all) 07, 08(limited qty) 17, 27, 28(index)		
30	1	32-Bit Analog Input	1 (read)	00, 01(start-stop) 06(no range, or all) 07, 08(limited qty) 17, 27, 28(index)	129 (response)	00, 01(start-st 17, 28(index – see note 2)
30	2	16-Bit Analog Input	1 (read)	00, 01(start-stop) 06(no range, or all) 07, 08(limited qty) 17, 27, 28(index)	129 (response)	00, 01(start-st 17, 28(index – see note 2)

OBJECT			REQUEST (Library will parse)		RESPONSE (Library will respond with)	
Object Number	Variation Number	Description	Function Codes (dec)	Qualifier Codes (hex)	Function Codes (dec)	Qualifier Codes (hex)
30	3 (default – see note 1)	32-Bit Analog Input without Flag	1 (read)	00, 01(start-stop) 06(no range, or all) 07, 08(limited qty) 17, 27, 28(index)	129 (response)	00, 01(start-st 17, 28(index – see note 2)
30	4	16-Bit Analog Input without Flag	1 (read)	00, 01(start-stop) 06(no range, or all) 07, 08(limited qty) 17, 27, 28(index)	129 (response)	00, 01(start-st 17, 28(index – see note 2)
30	5	short floating point	1 (read)	00, 01(start-stop) 06(no range, or all) 07, 08(limited qty) 17, 27, 28(index)	129 (response)	00, 01(start-st 17, 28(index – see note 2)
30	6	long floating point	1 (read)	00, 01(start-stop) 06(no range, or all) 07, 08(limited qty) 17, 27, 28(index)	129 (response)	00, 01(start-st 17, 28(index – see note 1)
31	0	Frozen Analog Input – Any Variation				
31	1	32-Bit Frozen Analog input				
31	2	16-Bit Frozen Analog input				
31	3	32-Bit Frozen Analog input with Time of freeze				
31	4	16-Bit Frozen Analog input with Time of freeze				
31	5	32-Bit Frozen Analog input without Flag				
31	6	16-Bit Frozen Analog input without Flag				
32	0	Analog Change Event – Any Variation	1 (read)	06 (no range, or all) 07, 08 (limited qty)		
32	1 (default – see note 1)	32-Bit Analog Change Event without Time	1 (read)	06 (no range, or all) 07, 08 (limited qty)	129 (response) 130 (unsol. resp)	17, 28 (index)
32	2	16-Bit Analog Change Event without Time	1 (read)	06 (no range, or all) 07, 08 (limited qty)	129 (response) 130 (unsol. resp)	17, 28 (index)
32	3	32-Bit Analog Change Event with Time	1 (read)	06 (no range, or all) 07, 08 (limited qty)	129 (response) 130 (unsol. resp)	17, 28 (index)

OBJECT			REQUEST (Library will parse)		RESPONSE (Library will respond with)	
Object Number	Variation Number	Description	Function Codes (dec)	Qualifier Codes (hex)	Function Codes (dec)	Qualifier Codes (hex)
32	4	16-Bit Analog Change Event with Time	1 (read)	06 (no range, or all) 07, 08 (limited qty)	129 (response) 130 (unsol. resp)	17, 28 (index)
32	5	short floating point Analog Change Event without Time	1 (read)	06 (no range, or all) 07, 08 (limited qty)	129 (response) 130 (unsol. resp)	17, 28 (index)
32	6	long floating point Analog Change Event without Time	1 (read)	06 (no range, or all) 07, 08 (limited qty)	129 (response) 130 (unsol. resp)	17, 28 (index)
32	7	short floating point Analog Change Event with Time	1 (read)	06 (no range, or all) 07, 08 (limited qty)	129 (response) 130 (unsol. resp)	17, 28 (index)
32	8	long floating point Analog Change Event with Time	1 (read)	06 (no range, or all) 07, 08 (limited qty)	129 (response) 130 (unsol. resp)	17, 28 (index)
33	0	Frozen Analog Event – Any Variation				
33	1	32-Bit Frozen Analog Event without Time				
33	2	16-Bit Frozen Analog Event without Time				
33	3	32-Bit Frozen Analog Event with Time				
33	4	16-Bit Frozen Analog Event with Time				
33	5	Short Floating Point Frozen Analog Event				
33	6	Long Floating Point Frozen Analog Event				
33	7	Extended Floating Point Frozen Analog Event				
34	0	Analog Input Deadband (Variation 0 is used to request default variation)	1 (read)	00, 01 (start-stop) 06 (no range, or all) 07, 08 (limited qty) 17, 27, 28 (index)		
34	1	16 bit Analog Input Deadband	1 (read)	00, 01 (start-stop) 06 (no range, or all) 07, 08 (limited qty) 17, 27, 28 (index)	129 (response)	00, 01 (start-stop) 17, 28 (index – see note 2)
			2 (write)	00, 01 (start-stop) 07, 08 (limited qty) 17, 27, 28 (index)		

OBJECT			REQUEST (Library will parse)		RESPONSE (Library will respond with)	
Object Number	Variation Number	Description	Function Codes (dec)	Qualifier Codes (hex)	Function Codes (dec)	Qualifier Codes (hex)
34	2 (default – see note 1)	32 bit Analog Input Deadband	1 (read)	00, 01 (start-stop) 06 (no range, or all) 07, 08 (limited qty) 17, 27, 28 (index)	129 (response)	00, 01 (start-stop) 17, 28 (index – see note 2)
			2 (write)	00, 01 (start-stop) 07, 08 (limited qty) 17, 27, 28 (index)		
34	3	Short Floating Point Analog Input Deadband	1 (read)	00, 01 (start-stop) 06 (no range, or all) 07, 08 (limited qty) 17, 27, 28 (index)	129 (response)	00, 01 (start-stop) 17, 28 (index – see note 2)
			2 (write)	00, 01 (start-stop) 07, 08 (limited qty) 17, 27, 28 (index)		
50	0	Time and Date				
50	1 (default – see note 1)	Time and Date	1 (read)	07, (limited qty = 1)	129 (response)	07 (limited qty)
			2 (write)	07(limited qty = 1)		
50	3	Time and Date Last Recorded Time	2 (write)	07(limited qty)		
51	1	Time and Date CTO			129 (response) 130 (unsol. resp)	07(limited qty) (qty = 1)
51	2	Unsynchronized Time and Date CTO			129 (response) 130 (unsol. resp)	07(limited qty) (qty = 1)
52	1	Time Delay Coarse			129 (response)	07(limited qty) (qty = 1)
52	2	Time Delay Fine			129 (response)	07(limited qty) (qty = 1)
60	0	Not Defined				
60	1	Class 0 Data	1 (read)	06(no range, or all)		
60	2	Class 1 Data	1 (read)	06(no range, or all) 07, 08(limited qty)		
			20(enbl. unsol.) 21(dab. unsol.) 22(assign class)	06(no range, or all)		

OBJECT			REQUEST (Library will parse)		RESPONSE (Library will respond with)	
Object Number	Variation Number	Description	Function Codes (dec)	Qualifier Codes (hex)	Function Codes (dec)	Qualifier Codes (hex)
60	3	Class 2 Data	1 (read)	06(no range, or all) 07, 08(limited qty)		
			20(enbl. unsol.) 21(dab. unsol.) 22(assign class)	06(no range, or all)		
60	4	Class 3 Data	1 (read)	06(no range, or all) 07, 08(limited qty)		
			20(enbl. unsol.) 21(dab. unsol.) 22(assign class)	06(no range, or all)		
80	1	Internal Indications	1 (read)	00, 01(start-stop)	129(response)	00, 01 (start-stop)
			2 (write) (see note 3)	00 (start-stop) index=7		
		No Object (function code only)	13(cold restart)			
		No Object (function code only)	14(warm restart)			
		No Object (function code only)	23(delay meas.)			
		No Object (function code only)	24 (record current time)			

Note 1: A Default variation refers to the variation responded when variation 0 is requested and/or in class 0, 1, 2, or 3 scans. Default variations are configurable; however, default settings for the configuration parameters are indicated in the table above.

Note 2: For static (non-change-event) objects, qualifiers 17 or 28 are only responded when a request is sent with qualifiers 17 or 28, respectively. Otherwise, static object requests sent with qualifiers 00, 01, 06, 07, or 08, will be responded with qualifiers 00 or 01. (For change-event objects, qualifiers 17 or 28 are always responded.)

Note 3: Writes of Internal Indications are only supported for index 7 (Restart IIN1-7)

5.3 Point List

The tables below identify all the default data points provided by the implementation of the Triangle MicroWorks, Inc. DNP 3.0 Slave Source Code Library.

Binary Input Points

The default binary input event buffer size is set to allow 100 events.

Note, not all points listed here apply to all builds of devices.

Static Variation reported when variation 0 requested: 2 (Binary Input 2 with status) Change Event Variation reported when variation 0 requested: 3 (Binary Input Change with Relative Time)				
Point Index	Name/Description	Default Class	Default Variation Static Object 1	Default Variation Event Object 2
1	Binary Input 1	2	2	2
2	Binary Input 2	2	2	2
3	Binary Input 3	2	2	2
4	Binary Input 4	2	2	2
5	Binary Input 5	2	2	2
6	Binary Input 6	2	2	2
7	Binary Input 7	2	2	2
8	Binary Input 8	2	2	2
9	Binary Input 9	2	2	2
10	Binary Input 10	2	2	2
11	Binary Input 11	2	2	2
12	Binary Input 12	2	2	2
13	Binary Input 13	2	2	2
14	Binary Input 14	2	2	2
15	Binary Input 15	2	2	2
16	Binary Input 16	2	2	2
17	Binary Input 17	2	2	2
18	Binary Input 18	2	2	2
19	Binary Input 19	2	2	2
20	<i>Binary Input 20</i>	2	2	2
21	<i>Binary Input 21</i>	2	2	2
22	<i>Binary Input 22</i>	2	2	2
23	<i>Binary Input 23</i>	2	2	2
24	<i>Binary Input 24</i>	2	2	2
25	<i>Binary Input 25</i>	2	2	2
26	<i>Binary Input 26</i>	2	2	2
27	<i>Binary Input 27</i>	2	2	2
28	<i>Binary Input 28</i>	2	2	2
29	<i>Binary Input 29</i>	2	2	2
30	<i>Binary Input 30</i>	2	2	2
31	<i>Binary Input 31</i>	2	2	2
32	<i>Binary Input 32</i>	2	2	2
35	Remote mode	2	2	2
36	Service mode	2	2	2
37	Local mode	2	2	2
38	Local & Remote	2	2	2
40	General Trip	2	2	2
41	Trip Circuit Fail	2	2	2
42	A-Starter	2	2	2
43	B-Starter	2	2	2

Static Variation reported when variation 0 requested: 2 (Binary Input 2 with status) Change Event Variation reported when variation 0 requested: 3 (Binary Input Change with Relative Time)				
Point Index	Name/Description	Default Class	Default Variation Static Object 1	Default Variation Event Object 2
44	C-Starter	2	2	2
45	General Starter	2	2	2
47	Trip L1	2	2	2
48	Trip L2	2	2	2
49	Start/Pick-up N	2	2	2
50	Trip L3	2	2	2
52	87BD	2	2	2
53	87HS	2	2	2
54	51-1	2	2	2
55	50-1	2	2	2
56	51N-1	2	2	2
57	50N-1	2	2	2
58	51G-1	2	2	2
59	50G-1	2	2	2
60	51-2	2	2	2
61	50-2	2	2	2
62	51N-2	2	2	2
63	50N-2	2	2	2
64	51G-2	2	2	2
65	50G-2	2	2	2
66	51-3	2	2	2
67	50-3	2	2	2
68	51N-3	2	2	2
69	50N-3	2	2	2
70	51G-3	2	2	2
71	50G-3	2	2	2
78	50BF-1-1	2	2	2
79	50BF-1-2	2	2	2
80	50BF-2-1	2	2	2
81	50BF-2-2	2	2	2
82	49-Alarm	2	2	2
83	49-Trip	2	2	2
84	60 CTS	2	2	2
85	46IT-1	2	2	2
86	46DT-1	2	2	2
87	46IT-2	2	2	2
88	46DT-2	2	2	2
89	64H-1	2	2	2
90	64H-2	2	2	2
91	64H-3	2	2	2
92	37-1	2	2	2
93	37-2	2	2	2
94	46BC-1	2	2	2
95	46BC-2	2	2	2
96	27/59-1	2	2	2
97	27/59-2	2	2	2
98	27/59-3	2	2	2
99	27/59-4	2	2	2
100	59NIT	2	2	2

Static Variation reported when variation 0 requested: 2 (Binary Input 2 with status) Change Event Variation reported when variation 0 requested: 3 (Binary Input Change with Relative Time)				
Point Index	Name/Description	Default Class	Default Variation Static Object 1	Default Variation Event Object 2
101	59NDT	2	2	2
102	81-1	2	2	2
103	81-2	2	2	2
104	81-3	2	2	2
105	81-4	2	2	2
106	81-5	2	2	2
107	81-6	2	2	2
108	24DT-1	2	2	2
109	24DT-2	2	2	2
110	24IT	2	2	2
111	Trip Circuit Fail 1	2	2	2
112	Trip Circuit Fail 2	2	2	2
113	Trip Circuit Fail 3	2	2	2
114	Trip Circuit Fail 4	2	2	2
115	Trip Circuit Fail 5	2	2	2
116	Trip Circuit Fail 6	2	2	2
121	CB1 Total Trip Count	2	2	2
122	CB1 Delta Trip Count	2	2	2
124	1/2t CB1 Wear	2	2	2
125	1/2t CB2 Wear	2	2	2
126	CB2 Total Trip Count	2	2	2
127	CB2 Delta Trip Count	2	2	2
129	General Alarm 1	2	2	2
130	General Alarm 2	2	2	2
131	General Alarm 3	2	2	2
132	General Alarm 4	2	2	2
133	General Alarm 5	2	2	2
134	General Alarm 6	2	2	2
135	General Alarm 7	2	2	2
136	General Alarm 8	2	2	2
137	General Alarm 9	2	2	2
138	General Alarm 10	2	2	2
139	General Alarm 11	2	2	2
140	General Alarm 12	2	2	2
141	Quick Logic E1	2	2	2
142	Quick Logic E2	2	2	2
143	Quick Logic E3	2	2	2
144	Quick Logic E4	2	2	2
145	Quick Logic E5	2	2	2
146	Quick Logic E6	2	2	2
147	Quick Logic E7	2	2	2
148	Quick Logic E8	2	2	2
149	Quick Logic E9	2	2	2
150	Quick Logic E10	2	2	2
151	Quick Logic E11	2	2	2
152	Quick Logic E12	2	2	2
153	Quick Logic E13	2	2	2
154	Quick Logic E14	2	2	2
155	Quick Logic E15	2	2	2
156	Quick Logic E16	2	2	2

Static Variation reported when variation 0 requested: 2 (Binary Input 2 with status) Change Event Variation reported when variation 0 requested: 3 (Binary Input Change with Relative Time)				
Point Index	Name/Description	Default Class	Default Variation Static Object 1	Default Variation Event Object 2
191	81HBL2	2	2	2
192	81HBL5	2	2	2
193	37G-1	2	2	2
194	37G-2	2	2	2
195	Close Circuit Fail 1	2	2	2
196	Close Circuit Fail 2	2	2	2
197	Close Circuit Fail 3	2	2	2
198	Close Circuit Fail 4	2	2	2
199	Close Circuit Fail 5	2	2	2
200	Close Circuit Fail 6	2	2	2
201	Close Circuit Fail 7	2	2	2
202	Close Circuit Fail 8	2	2	2
203	Close Circuit Fail 9	2	2	2
204	Close Circuit Fail 10	2	2	2
205	CB1 Trip Time Alarm	2	2	2
206	CB2 Trip Time Alarm	2	2	2
207	Close CB1	2	2	2
208	CB1 Fail To Close	2	2	2
209	CB1 DBI	2	2	2
210	Open CB1	2	2	2
211	CB1 Fail To Open	2	2	2
212	Close CB2	2	2	2
213	CB2 Fail To Close	2	2	2
214	CB2 DBI	2	2	2
215	Open CB2	2	2	2
216	CB2 Fail To Open	2	2	2
217	E/F Out	2	2	2
221	RL 1	2	2	2
222	RL 2	2	2	2
223	RL 3	2	2	2
224	RL 4	2	2	2
225	RL 5	2	2	2
226	RL 6	2	2	2
227	RL 7	2	2	2
228	RL 8	2	2	2
229	RL 9	2	2	2
230	RL 10	2	2	2
231	RL 11	2	2	2
232	RL 12	2	2	2
233	RL 13	2	2	2
234	RL 14	2	2	2
254	Setting G1 selected	2	2	2
255	Setting G2 selected	2	2	2
256	Setting G3 selected	2	2	2
257	Setting G4 selected	2	2	2
258	Setting G5 selected	2	2	2
259	Setting G6 selected	2	2	2
260	Setting G7 selected	2	2	2
261	Setting G8 selected	2	2	2

Static Variation reported when variation 0 requested: 2 (Binary Input 2 with status) Change Event Variation reported when variation 0 requested: 3 (Binary Input Change with Relative Time)				
Point Index	Name/Description	Default Class	Default Variation Static Object 1	Default Variation Event Object 2
262	CB 1	2	2	2
263	CB 2	2	2	2
268	Reset I ² t CB1 Wear	2	2	2
269	Reset I ² t CB2 Wear	2	2	2
277	CB 3	2	2	2
278	CB 4	2	2	2
279	CB 5	2	2	2
501	Virtual Input 1	2	2	2
502	Virtual Input 2	2	2	2
503	Virtual Input 3	2	2	2
504	Virtual Input 4	2	2	2
505	Virtual Input 5	2	2	2
506	Virtual Input 6	2	2	2
507	Virtual Input 7	2	2	2
508	Virtual Input 8	2	2	2
509	Virtual Input 9	2	2	2
510	Virtual Input 10	2	2	2
511	Virtual Input 11	2	2	2
512	Virtual Input 12	2	2	2
513	Virtual Input 13	2	2	2
514	Virtual Input 14	2	2	2
515	Virtual Input 15	2	2	2
516	Virtual Input 16	2	2	2
601	Led 1	2	2	2
602	Led 2	2	2	2
603	Led 3	2	2	2
604	Led 4	2	2	2
605	Led 5	2	2	2
606	Led 6	2	2	2
607	Led 7	2	2	2
608	Led 8	2	2	2
609	Led 9	2	2	2
610	Led 10	2	2	2
611	Led 11	2	2	2
612	Led 12	2	2	2
613	Led 13	2	2	2
614	Led 14	2	2	2
615	Led 15	2	2	2
616	Led 16	2	2	2
617	Led 17	2	2	2
618	Led 18	2	2	2
619	Led 19	2	2	2
620	Led 20	2	2	2
621	Led 21	2	2	2
622	Led 22	2	2	2
623	Led 23	2	2	2
624	Led 24	2	2	2

Static Variation reported when variation 0 requested: 2 (Binary Input 2 with status) Change Event Variation reported when variation 0 requested: 3 (Binary Input Change with Relative Time)				
Point Index	Name/Description	Default Class	Default Variation Static Object 1	Default Variation Event Object 2
701	Led PU 1	2	2	2
702	Led PU 2	2	2	2
703	Led PU 3	2	2	2
704	Led PU 4	2	2	2
705	Led PU 5	2	2	2
706	Led PU 6	2	2	2
707	Led PU 7	2	2	2
708	Led PU 8	2	2	2
709	Led PU 9	2	2	2
710	Led PU 10	2	2	2
711	Led PU 11	2	2	2
712	Led PU 12	2	2	2
713	Led PU 13	2	2	2
714	Led PU 14	2	2	2
715	Led PU 15	2	2	2
716	Led PU 16	2	2	2
717	Led PU 17	2	2	2
718	Led PU 18	2	2	2
719	Led PU 19	2	2	2
720	Led PU 20	2	2	2
721	Led PU 21	2	2	2
722	Led PU 22	2	2	2
723	Led PU 23	2	2	2
724	Led PU 24	2	2	2

5.3.1 Double Bit Binary Input Points

Double Bit Binary Inputs are by default returned in a class zero interrogation.

Double Bit Input Points Static (Steady-State) Object Number: 3 Change Event Object Number: 4 Default Static Variation reported when variation 0 requested: 1 (Double Bit Binary Input packed format) Default Change Event Variation reported when variation 0 requested: 3 (Double Bit Binary Input Event with relative time)		
Point Index	Name/Description	Default Change Event Assigned Class (1, 2, 3 or none)
0	CB 1	2
1	CB 2	2

Binary Output Status Points and Control Relay Output Blocks

The following table lists both the Binary Output Status Points (Object 10) and the Control Relay Output Blocks (Object 12).

While Binary Output Status Points are included here for completeness, they are not often polled by DNP 3.0 Masters. It is recommended that Binary Output Status points represent the most recent DNP “commanded” value for the corresponding Control Relay Output Block (CROB) point. Because many, if not most, Control Relay Output Block points are controlled through pulse mechanisms, the value of the output status may in fact be meaningless. Binary Output Status points are not recommended to be included in class 0 polls.

As an alternative, it is recommended that “actual” status values of Control Relay Output Block points be looped around and mapped as Binary Inputs. (The “actual” status value, as opposed to the “commanded” status value, is the value of the actuated control. For example, a DNP control command may be blocked through hardware or software mechanisms; in this case, the actual status value would indicate the control failed because of the blocking. Looping Control Relay Output Block actual status values as Binary Inputs has several advantages:

- it allows actual statuses to be included in class 0 polls,
- it allows change event reporting of the actual statuses, which is a more efficient and time-accurate method of communicating control values,
- and it allows reporting of time-based information associated with controls, including any delays before controls are actuated, and any durations if the controls are pulsed.

The default select/control buffer size is large enough to hold 10 of the largest select requests possible.

Default Variation reported when variation 0 requested: 2 (Binary Output Status)						
Control Relay Output Blocks						
Object Number: 12						
Point Index	Name/Description	Default Class	Default Static Object 10 Variation	Default Event Object 11 Variation	Supported CROB Fields	Default CROB Fields
1	Binary Output 1	0	2	2	Pulse On Latch On	Pulse On
2	Binary Output 2	0	2	2	Pulse On Latch On	Pulse On
3	Binary Output 3	0	2	2	Pulse On Latch On	Pulse On
4	Binary Output 4	0	2	2	Pulse On Latch On	Pulse On
5	Binary Output 5	0	2	2	Pulse On Latch On	Pulse On
6	Binary Output 6	0	2	2	Pulse On Latch On	Pulse On
7	Binary Output 7	0	2	2	Pulse On Latch On	Pulse On
8	Binary Output 8	0	2	2	Pulse On Latch On	Pulse On
9	Binary Output 9	0	2	2	Pulse On Latch On	Pulse On
10	Binary Output 10	0	2	2	Pulse On Latch On	Pulse On
11	Binary Output 11	0	2	2	Pulse On Latch On	Pulse On
12	Binary Output 12	0	2	2	Pulse On Latch On	Pulse On
13	Binary Output 13	0	2	2	Pulse On Latch On	Pulse On
14	Binary Output 14	0	2	2	Pulse On Latch On	Pulse On
		0				
33	LED reset	0	2	2	Pulse On Latch On	Pulse On
34	Settings Group 1	0	2	2	Pulse On Latch On	Latch On
35	Settings Group 2	0	2	2	Pulse On Latch On	Latch On

Default Variation reported when variation 0 requested: 2 (Binary Output Status)						
Control Relay Output Blocks						
Object Number: 12						
Point Index	Name/Description	Default Class	Default Static Object 10 Variation	Default Event Object 11 Variation	Supported CROB Fields	Default CROB Fields
36	Settings Group 3	0	2	2	Pulse On Latch On	Latch On
37	Settings Group 4	0	2	2	Pulse On Latch On	Latch On
38	Settings Group 5	0	2	2	Pulse On Latch On	Latch On
39	Settings Group 6	0	2	2	Pulse On Latch On	Latch On
40	Settings Group 7	0	2	2	Pulse On Latch On	Latch On
41	Settings Group 8	0	2	2	Pulse On Latch On	Latch On
42	CB 1	0	2	2	Pulse On Pulse Off Latch On Latch Off	Pulse On Pulse Off
43	CB 2	0	2	2	Pulse On Pulse Off Latch On Latch Off	Pulse On Pulse Off
44	Demand metering reset, write only location.	0	2	2	Pulse On Latch On	Pulse On
45	Reset CB1 Total Trip Count, write only location.	0	2	2	Pulse On Latch On	Pulse On
46	Reset CB1 Delta Trip Count, write only location.	0	2	2	Pulse On Latch On	Pulse On
47	Reset CB1 Lockout Trip Count, write only location.	0	2	2	Pulse On Latch On	Pulse On
48	Reset I ² t CB1 Wear	0	2	2	Pulse On Latch On	Pulse On
49	Reset I ² t CB2 Wear	0	2	2	Pulse On Latch On	Pulse On
50	Reset CB2 Total Trip Count, write only location.	0	2	2	Pulse On Latch On	Pulse On
51	Reset CB2 Delta Trip Count, write only location.	0	2	2	Pulse On Latch On	Pulse On
52	Reset CB2 Lockout Trip Count, write only location.	0	2	2	Pulse On Latch On	Pulse On
53	Remote mode	0	2	2	Pulse On Latch On	Pulse On
54	Service mode	0	2	2	Pulse On Latch On	Pulse On
55	Local mode	0	2	2	Pulse On Latch On	Pulse On
56	Local & Remote	0	2	2	Pulse On Latch On	Pulse On
60	E/F Out	0	2	2	Pulse On Pulse Off Latch On Latch Off	Pulse On Pulse Off
96	User SP Command 1	0	2	2	Pulse On Latch On	Pulse On
97	User SP Command 2	0	2	2	Pulse On Latch On	Pulse On
98	User SP Command 3	0	2	2	Pulse On Latch On	Pulse On
99	User SP Command 4	0	2	2	Pulse On Latch On	Pulse On

Default Variation reported when variation 0 requested: 2 (Binary Output Status)						
Control Relay Output Blocks						
Object Number: 12						
Point Index	Name/Description	Default Class	Default Static Object 10 Variation	Default Event Object 11 Variation	Supported CROB Fields	Default CROB Fields
100	User SP Command 5	0	2	2	Pulse On Latch On	Pulse On
101	User SP Command 6	0	2	2	Pulse On Latch On	Pulse On
102	User SP Command 7	0	2	2	Pulse On Latch On	Pulse On
103	User SP Command 8	0	2	2	Pulse On Latch On	Pulse On
104	User DP Command 1	0	2	2	Pulse On Pulse Off Latch On Latch Off	Pulse On Pulse Off
105	User DP Command 2	0	2	2	Pulse On Pulse Off Latch On Latch Off	Pulse On Pulse Off
106	User DP Command 3	0	2	2	Pulse On Pulse Off Latch On Latch Off	Pulse On Pulse Off
107	User DP Command 4	0	2	2	Pulse On Pulse Off Latch On Latch Off	Pulse On Pulse Off
108	User DP Command 5	0	2	2	Pulse On Pulse Off Latch On Latch Off	Pulse On Pulse Off
109	User DP Command 6	0	2	2	Pulse On Pulse Off Latch On Latch Off	Pulse On Pulse Off
110	User DP Command 7	0	2	2	Pulse On Pulse Off Latch On Latch Off	Pulse On Pulse Off
111	User DP Command 8	0	2	2	Pulse On Pulse Off Latch On Latch Off	Pulse On Pulse Off

5.3.2 Binary Counters

The following table lists both the Counters (Object 20) and Counter change events (Object 22).

The "Default Deadband," and the "Default Change Event Assigned Class" columns are used to represent the absolute amount by which the point must change before a Counter change event will be generated, and once generated in which class poll (1, 2, 3, or none) will the change event be reported.

Counters are by default returned in a class zero interrogation.

Counters					
Static (Steady-State) Object Number: 20					
Change Event Object Number: 22					
Default Static Variation reported when variation 0 requested: 5 (32-Bit Counter without Flag)					
Default Change Event Variation reported when variation 0 requested: 1 (32-Bit Change Event with Flag)					
Point #	Default Class	Default Static Variant	Default Event Variant	Name	Deadband
0	3	5	1	Waveform Records	1
1	3	5	1	Fault Records	1
2	3	5	1	Event Records	1
3	3	5	1	Data Log Records	1
4	3	5	1	Number User Files	1
5	3	5	1	Start Count	1
6	3	5	1	Start Count Target	1
7	3	5	1	Active Setting Group	1
21	3	5	1	E1 Counter	1
22	3	5	1	E2 Counter	1
23	3	5	1	E3 Counter	1
24	3	5	1	E4 Counter	1
25	3	5	1	E5 Counter	1
26	3	5	1	E6 Counter	1
27	3	5	1	E7 Counter	1
28	3	5	1	E8 Counter	1
29	3	5	1	E9 Counter	1
30	3	5	1	E10 Counter	1
31	3	5	1	E11 Counter	1
32	3	5	1	E12 Counter	1
33	3	5	1	E13 Counter	1
34	3	5	1	E14 Counter	1
35	3	5	1	E15 Counter	1
36	3	5	1	E16 Counter	1
42	3	5	1	CB1 Total Open Count	1
43	3	5	1	CB1 Delta Open Count	1
44	3	5	1	CB2 Total Open Count	1
45	3	5	1	CB2 Delta Open Count	1

5.3.3 Frozen Counters

The following table lists both the Frozen Counters (Object 21) and Frozen Counter Change Events (Object 23).

The "Default Change Event Assigned Class" column is used to define which class poll (1, 2, 3, or none) the change event will be reported.

Note the point number of the Frozen Counter must match that of the corresponding Counter.

Frozen Counters are by default not returned in a class zero interrogation.

Frozen Counters					
Static (Steady-State) Object Number: 21					
Change Event Object Number: 23					
Default Static Variation reported when variation 0 requested: 9 (32-Bit Counter without Flag)					
Default Change Event Variation reported when variation 0 requested: 1 (32-Bit Change Event with Flag)					
Point #	Default Class	Default Static Variant	Default Event Variant	Name	Resettable
0	2	9	1	Waveform Records	<input type="checkbox"/>
1	2	9	1	Fault Records	<input type="checkbox"/>
2	2	9	1	Event Records	<input type="checkbox"/>
3	2	9	1	Data Log Records	<input type="checkbox"/>
4	2	9	1	Number User Files	<input type="checkbox"/>
5	2	9	1	Start Count	<input checked="" type="checkbox"/>
6	2	9	1	Start Count Target	<input type="checkbox"/>
7	2	9	1	Active Setting Group	<input type="checkbox"/>
21	2	9	1	E1 Counter	<input type="checkbox"/>
22	2	9	1	E2 Counter	<input type="checkbox"/>
23	2	9	1	E3 Counter	<input type="checkbox"/>
24	2	9	1	E4 Counter	<input type="checkbox"/>
25	2	9	1	E5 Counter	<input type="checkbox"/>
26	2	9	1	E6 Counter	<input type="checkbox"/>
27	2	9	1	E7 Counter	<input type="checkbox"/>
28	2	9	1	E8 Counter	<input type="checkbox"/>
29	2	9	1	E9 Counter	<input type="checkbox"/>
30	2	9	1	E10 Counter	<input type="checkbox"/>
31	2	9	1	E11 Counter	<input type="checkbox"/>
32	2	9	1	E12 Counter	<input type="checkbox"/>
33	2	9	1	E13 Counter	<input type="checkbox"/>
34	2	9	1	E14 Counter	<input type="checkbox"/>
35	2	9	1	E15 Counter	<input type="checkbox"/>
36	2	9	1	E16 Counter	<input type="checkbox"/>
42	2	9	1	CB1 Total Open Count	
43	2	9	1	CB1 Delta Open Count	
44	2	9	1	CB2 Total Open Count	
45	2	9	1	CB2 Delta Open Count	

Analog Inputs

The following table lists Analog Inputs (Object 30). It is important to note that 16-bit and 32-bit variations of Analog Inputs, Analog Output Control Blocks, and Analog Output Statuses are transmitted through DNP as signed numbers.

The "Default Deadband," and the "Default Change Event Assigned Class" columns are used to represent the absolute amount by which the point must change before an analog change event will be generated, and once generated in which class poll (1, 2, 3, or none) will the change event be reported.

The default analog input event buffer size is set 30.

Static Variation reported when variation 0 requested: 3 (32-Bit Analog Input w/o Flag), 4 (16-Bit Analog Input w/o Flag)						
Change Event Variation reported when variation 0 requested: 1 (32-Bit Analog Change Event w/o Time)						
Point Index	Name/Description	Default Class	Default Static Object 30 Variation	Default Event Object 32 Variation	Multiplier	Deadband
0	Frequency (Hz)	3	2	4	100	1
1	V Primary (kV)	3	2	4	0.001	1000
2	Voltage Secondary	3	2	4	100	1
3	Voltage Nominal	3	2	4	100	1
4	Operate Ia	3	2	4	100	1
5	Operate Ib	3	2	4	100	1
6	Operate Ic	3	2	4	100	1
7	Restrain Ia	3	2	4	100	1
8	Restrain Ib	3	2	4	100	1
9	Restrain Ic	3	2	4	100	1
10	W1 2 nd Harmonic Ia	3	2	4	100	1
11	W1 2 nd Harmonic Ib	3	2	4	100	1
12	W1 2 nd Harmonic Ic	3	2	4	100	1
13	W2 2 nd Harmonic Ia	3	2	4	100	1
14	W2 2 nd Harmonic Ib	3	2	4	100	1
15	W2 2 nd Harmonic Ic	3	2	4	100	1
16	Primary Ig-1	3	2	4	100	1
17	Secondary Ig-1	3	2	4	100	1
18	Nominal Ig-1	3	2	4	100	1
19	Primary Ig-2	3	2	4	100	1
20	Secondary Ig-2	3	2	4	100	1
21	Nominal Ig-2	3	2	4	100	1
22	V/f V	3	2	4	100	1
23	V/f	3	2	4	100	1
24	V/f 24IT	3	2	4	100	1
25	Thermal Status Ph A	3	2	4	100	1
26	Thermal Status Ph B	3	2	4	100	1
27	Thermal Status Ph C	3	2	4	100	1
28	W1 Primary Ia	3	2	4	0.001	1000
29	W1 Primary Ib	3	2	4	0.001	1000
30	W1 Primary Ic	3	2	4	0.001	1000
31	W1 Secondary Ia	3	2	4	100	1
32	W1 Secondary Ib	3	2	4	100	1
33	W1 Secondary Ic	3	2	4	100	1
34	W1 Nominal Ia	3	2	4	100	1
35	W1 Nominal Ib	3	2	4	100	1
36	W1 Nominal Ic	3	2	4	100	1
37	W1 Line Ia	3	2	4	100	1
38	W1 Line Ib	3	2	4	100	1
39	W1 Line Ic	3	2	4	100	1
40	W1 Relay Ia	3	2	4	100	1

Static Variation reported when variation 0 requested: 3 (32-Bit Analog Input w/o Flag), 4 (16-Bit Analog Input w/o Flag)						
Change Event Variation reported when variation 0 requested: 1 (32-Bit Analog Change Event w/o Time)						
Point Index	Name/Description	Default Class	Default Static Object 30 Variation	Default Event Object 32 Variation	Multiplier	Deadband
41	W1 Relay Ib	3	2	4	100	1
42	W1 Relay Ic	3	2	4	100	1
43	W2 Primary Ia	3	2	4	0.001	1000
44	W2 Primary Ib	3	2	4	0.001	1000
45	W2 Primary Ic	3	2	4	0.001	1000
46	W2 Secondary Ia	3	2	4	100	1
47	W2 Secondary Ib	3	2	4	100	1
48	W2 Secondary Ic	3	2	4	100	1
49	W2 Nominal Ia	3	2	4	100	1
50	W2 Nominal Ib	3	2	4	100	1
51	W2 Nominal Ic	3	2	4	100	1
52	W2 Line Ia	3	2	4	100	1
53	W2 Line Ib	3	2	4	100	1
54	W2 Line Ic	3	2	4	100	1
55	W2 Relay Ia	3	2	4	100	1
56	W2 Relay Ib	3	2	4	100	1
57	W2 Relay Ic	3	2	4	100	1
58	W3 Primary Ia A	3	2	4	0.001	1000
59	W3 Primary Ib A	3	2	4	0.001	1000
60	W3 Primary Ic A	3	2	4	0.001	1000
61	W3 Secondary Ia A	3	2	4	100.0	1
62	W3 Secondary Ib A	3	2	4	100.0	1
63	W3 Secondary Ic A	3	2	4	100.0	1
64	W3 Ia xIn	3	2	4	100.0	1
65	W3 Ib xIn	3	2	4	100.0	1
66	W3 Ic xIn	3	2	4	100.0	1
67	W3 Line Ia xIn	3	2	4	100.0	1
68	W3 Line Ib xIn	3	2	4	100.0	1
69	W3 Line Ic xIn	3	2	4	100.0	1
70	W3 Relay Ia xIn	3	2	4	100.0	1
71	W3 Relay Ib xIn	3	2	4	100.0	1
72	W3 Relay Ic xIn	3	2	4	100.0	1
73	Fault Records	3	4	4	1	1
74	Event Records	3	4	4	1	1
75	Waveform Records	3	4	4	1	1
76	W1 I Phase A Max	3	2	4	100	1
77	W1 I Phase B Max	3	2	4	100	1
78	W1 I Phase C Max	3	2	4	100	1
79	W2 I Phase A Max	3	2	4	100	1
80	W2 I Phase B Max	3	2	4	100	1
81	W2 I Phase C Max	3	2	4	100	1
82	W3 Max Current Ia	3	2	4	100.0	1
83	W3 Max Current Ib	3	2	4	100.0	1
84	W3 Max Current Ic	3	2	4	100.0	1
91	Data Log Records	3	4	4	1	1
92	Number User Files	3	4	4	1	1
110	W1 Ia Fault	3	2	4		
111	W1 Ib Fault	3	2	4		
112	W1 Ic Fault	3	2	4		

Static Variation reported when variation 0 requested: 3 (32-Bit Analog Input w/o Flag), 4 (16-Bit Analog Input w/o Flag)						
Change Event Variation reported when variation 0 requested: 1 (32-Bit Analog Change Event w/o Time)						
Point Index	Name/Description	Default Class	Default Static Object 30 Variation	Default Event Object 32 Variation	Multiplier	Deadband
113	W2 Ia Fault					
114	W2 Ib Fault					
115	W2 Ic Fault					
116	Ph-Ph Fault Voltage					
117	Ig-1 Last					
118	Ig-2 Last					
119	CB1 Wear A					
120	CB1 Wear B					
121	CB1 Wear C					
122	CB2 Wear A					
123	CB2 Wear B					
124	CB2 Wear C					

Data Type	Static Variant	Description
DT1	3	Data is sent as a 32 bit integer in fixed point to 3 decimal places format. E.g. a value of 1023 = 1.023
DT2	4	Data is sent as a 16 bit integer.

Section 6: IEC61850 Protocol Support

The relay can optionally be provided with IEC61850 comms.

For further details refer to the following publications:

- Model Implementation Conformance Statement (MICS)

- Protocol Implementation Conformance Statement (PICS)

- Protocol Implementation Extra Information for Testing (PIXIT)

Section 7: Modems

The communications interface has been designed to allow data transfer via modems. However, IEC 60870-5-103 defines the data transfer protocol as an 11 bit format of 1 start, 1 stop, 8 data and even parity, which is a mode most commercial modems do not support. High performance modems will support this mode, but are expensive. For this reason, a parity setting is provided to allow use of easily available and relatively inexpensive commercial modems. This will result in a small reduction in data security and the system will not be compatible with true IEC 60870-5-103 control systems.

7.1.1 Connecting a Modem to the Relay(s)

RS232C defines devices as being either Data Terminal Equipment (DTE) e.g. computers, or data Communications Equipment (DCE), e.g. modems, where one is designed to be connected to the other.

Where two DCE devices e.g. the modem and the fibre-optic converter are being connected together a null terminal connector is required which switches various control lines. The fibre-optic converter is then connected to the relay Network Tx to Relay Rx and Network Rx to Relay Tx.

7.1.2 Setting the Remote Modem

The exact settings of the modem are dependent on the type of modem. Although most modems support the basic Hayes 'AT' command format, different manufacturers use different commands for the same functions. In addition, some modems use DIP switches to set parameters, others are entirely software configured.

Before applying settings, the modem's factory default settings should be applied, to ensure it is in a known state.

Several factors must be considered to allow remote dialling to the relays. The first is that the modem at the remote end must be configured as auto answer. This will allow it to initiate communications with the relays. Next, the user should set the data configuration at the local port, i.e. baud rate and parity, so that communication will be at the same rate and format as that set on the relay and the error correction is disabled.

Auto-answer usually requires two parameters to be set. The auto-answer setting should be switched on and the number of rings after which it will answer. The Data Terminal Ready (DTR) settings should be forced on. This tells the modem that the device connected to it is ready to receive data.

The parameters of the modem's RS232C port are set to match those set on the relay, set baud rate and parity to be the same as the settings on the relay and number of data bits to be 8 and stop bits 1. Note, although the device may be able to communicate with the modem at say 19200 bps, the modem may only be able to transmit over the telephone lines at 14400 bps. Therefore, a baud rate setting on which the modem can transmit should be chosen. In this example, a baud rate of 9600 should be chosen.

As the modems are required to be transparent, simply passing on the data sent from the controller to the device and vice versa, error correction and buffering is turned off.

If possible, Data Carrier Detect (DCD) should be forced on, as this control line will be used by the Fibre-optic converter.

Finally, these settings should be stored in the modem's memory for power on defaults.

7.1.3 Connecting to the Remote Modem

Once the remote modem has been configured correctly, it should be possible to make connection to the relay.

Where a 'dial-up' modem system is installed the settings on the remote modem are fixed so the local modem should negotiate with it on connection, choosing suitable matching settings. Where this is not possible the local modem should be set with settings equivalent to those of the remote modem as described above.

Section 8: Glossary

Baud Rate

Data transmission speed.

Bit

The smallest measure of computer data.

Bits Per Second (bps)

Measurement of data transmission speed.

Data Bits

A number of bits containing the data. Sent after the start bit.

Data Echo

When connecting relays in an optical ring architecture, the data must be passed from one relay to the next, therefore when connecting in this method all relays must have the Data Echo ON.

Half-Duplex Asynchronous Communications

Communications in two directions, but only one at a time.

Hayes 'AT'

Modem command set developed by Hayes Microcomputer products, Inc.

Line Idle

Determines when the device is not communicating if the idle state transmits light.

Modem

MOdulator / DEModulator device for connecting computer equipment to a telephone line.

Parity

Method of error checking by counting the value of the bits in a sequence, and adding a parity bit to make the outcome, for example, even.

Parity Bit

Bit used for implementing parity checking. Sent after the data bits.

RS232C

Serial Communications Standard. Electronic Industries Association Recommended Standard Number 232, Revision C.

RS485

Serial Communications Standard. Electronic Industries Association Recommended Standard Number 485.

Start Bit

Bit (logical 0) sent to signify the start of a byte during data transmission.

Stop Bit

Bit (logical 1) sent to signify the end

USB

Universal Serial Bus standard for the transfer of data.

7SR242 Duobias

Multi-Function 2-Winding Transformer Protection Relay

Installation Guide

Document Release History

This document is issue 2018/07. The list of revisions up to and including this issue is:

2018/07	Addition of Disposal information
2017/12	Software revision 2662H85001 R8e-7e
2017/08	Software revision 2662H85001 R8c-7d
2016/11	Ethernet redundancy added to electrical interface
2015/11	7SR2424 E12 case dimensions (Figure 3.1-3) added, wiring diagram (Figure 5.1-1) revised.
2014/04	Revision to section 1.2
2013/01	Software revision 2662H85001 R7c-7b
2012/08	Addition of optional IEC 61850 communication protocol and Ethernet Interface.
2010/06	Additional Comms modules option of (RS485 + IRIG-B) and (RS232 + IRIG-B) and typographical revisions
2010/02	Document reformat due to rebrand
2010/02	Third issue. Software revision 2662H80001 R4c-3
2008/07	Second issue. Software revision 2662H80001R3d-2c.
2008/05	First issue

The copyright and other intellectual property rights in this document, and in any model or article produced from it (and including any registered or unregistered design rights) are the property of Siemens Protection Devices Limited. No part of this document shall be reproduced or modified or stored in another form, in any data retrieval system, without the permission of Siemens Protection Devices Limited, nor shall any model or article be reproduced from this document unless Siemens Protection Devices Limited consent.

While the information and guidance given in this document is believed to be correct, no liability shall be accepted for any loss or damage caused by any error or omission, whether such error or omission is the result of negligence or any other cause. Any and all such liability is disclaimed.

Contents

Installation Guide	1
Document Release History	1
Contents	3
List of Figures	4
Section 1: Installation	5
1.1 Packaging	5
1.2 Unpacking, Storage and Handling	5
1.3 Recommended Mounting Position	5
1.4 Wiring	5
1.5 Earthing	5
1.6 Ancillary Equipment	5
1.7 Disposal	6
1.7.1 Environmental Protection Hints.....	6
Section 2: Equipment Operating Conditions	7
Section 3: Dimensions and Panel Fixings	8
3.1 Relay Dimensions	8
3.2 Fixings.....	11
3.2.1 Crimps	11
3.2.2 Panel Fixings.....	11
Section 4: Rear Terminal Drawings	12
4.1 E8 CASE	12
4.2 E10 CASE	14
Section 5: Connection/Wiring/Diagrams	17
5.1 Wiring Diagram: 7SR242 Relay	17
Section 6: Data Comms Connections	19
6.1 RS485 Connection	19
6.2 IRIG-B Connections	19
6.3 Optional Fibre Optic Connections	20
6.4 Optional Additional RS485 Connections.....	21
6.5 Optional RS232 Connections.....	21
6.6 Additional (Optional) Ethernet Connection for IEC 61850	22
6.7 Ethernet Network Redundancy IEC 61850.....	23
6.7.1 RSTP – Rapid Spanning Tree Protocol	24
6.7.2 PRP – Parallel Redundancy Protocol	25
6.7.3 HSR – High Availability Seamless Redundancy Protocol.....	26
Section 7: Connection Diagrams	27
7.1 Typical AC Connections: 7SR242	27

List of Figures

Figure 3.1-1 Overall Dimensions and panel Drilling for Size E8 Epsilon case	8
Figure 3.1-2 Overall Dimensions and panel Drilling for Size E10 Epsilon case	9
Figure 3.1-3 Overall Dimensions and panel Drilling for Size E12 Epsilon case	10
Figure 5.1-1 7SR242 Wiring Diagram	17
Figure 6.1-1 RS485 Data Comms Connections	19
Figure 6.3-1 Data Comms to Multiple Devices Using Sigma 1 and F.O. Star Network	20
Figure 6.3-2 Data Comms to Multiple Devices Using Sigma 3 and F.O. Ring Network	20
Figure 6.5-1 RS232 Data Comms Pin Connections	21
Figure 6.6-1 Ethernet connection for IEC 61850 (star connection)	22
Figure 6.6-2 Ethernet connection for Fibre Optic IEC 61850 (ring connection)	22
Figure 6.7-1 RSTP Ethernet Network Ring Configuration	24
Figure 6.7-2 PRP Ethernet Network Configuration	25
Figure 6.7-3 HSR Ethernet Network Ring Configuration	26
Figure 7.1-1 7SR24 Typical Connections	27

Section 1: Installation

1.1 Packaging

Relays are supplied in packaging designed to mechanically protect them while in both transit and storage.

This packaging should be recycled where systems exist, or disposed of in a manner which does not provide a threat to health or the environment. All laws and regulations specific to the country of disposal should be adhered to.

1.2 Unpacking, Storage and Handling

On receipt remove the relay from the container in which it was received and inspect it for obvious damage. It is recommended that the relay not be removed from its case.

If damage has been sustained a claim should be immediately be made against the carrier, also inform *Siemens Protection Devices Limited* and to the nearest *Siemens* agent, using the Defect Report Form in the Maintenance section of this manual.

When not required for immediate use the relay should be returned to its original carton and stored in a clean, dry place.

The relay contains static sensitive devices, which are susceptible to damage due to static discharge. The relay's electronic circuits are protected from damage by static discharge when the relay is housed in its case. The relay element should not be withdrawn or reinserted into the relay case while auxiliary voltage is present.

There can be no requirement to disassemble any relay, since there are no user serviceable parts in the relay. If any modules have been tampered with the guarantee will be invalidated. *Siemens Protection Devices Limited* reserves the right to charge for any subsequent repairs.

1.3 Recommended Mounting Position

The relay uses a liquid crystal display (LCD) which is used in the programming and for operation. The LCD has a vertical viewing angle of $\pm 30^\circ$ and is back-lit. However, the best viewing position is at eye level, and this is particularly important given its control features.

The relay should be mounted on the circuit breaker (or protection panel) to allow the operator the best access to the relay functions

1.4 Wiring

The product should be wired according to the scheme requirements, with reference to the appropriate wiring diagram. Refer to the appropriate Diagrams and Parameters document for a cross reference of wiring diagrams and models.

1.5 Earthing

Terminal 28 of the PSU (Power Supply Unit) should be solidly earthed by a direct connection to the panel earth. The relay case earth stud connection should be connected to terminal 28 of the PSU.

It is normal practice to additionally 'daisy chain' together the case (safety) earths of all the relays installed in a panel to prevent earth current loops posing a risk to personnel.

1.6 Ancillary Equipment

The relay can be interrogated locally or remotely. For local interrogation a portable PC with suitable version of MS Windows and Reydisp™ s/w using USB port situated on front of the relay.

1.7 Disposal

The Relay should be disposed of in a manner which does not provide a threat to health or the environment. All laws and regulations specific to the country of disposal should be adhered to.

1.7.1 Environmental Protection Hints

Disposal of Old Equipment and Batteries (Applicable only for European Union and Countries with a Recycling System)

The disposal of our products and possible recycling of their components after decommissioning has to be carried out by an accredited recycling company, or the products/components must be taken to applicable collection points. Such disposal activities must comply with all local laws, guidelines and environmental specifications of the country in which the disposal is done. For the European Union the sustainable disposal of electronic scrap is defined in the respective regulation for "waste electrical and electronic equipment" (WEEE).



The crossed-out wheeled bin on the products, packaging and/or accompanying documents means that used electrical and electronic products and batteries must not be mixed with normal household waste.

According to national legislation, penalties may be charged for incorrect disposal of such waste.

By disposing of these products correctly you will help to save valuable resources and prevent any potential negative effects on human health and the environment.

NOTE: Our products and batteries must not be disposed of as household waste. For disposing batteries it is necessary to observe the local national/international directives.

Disposal of Mobile Storage Devices (e.g. USB Sticks and Memory Cards)

When disposing of/transferring mobile storage devices, using the **format** or **delete** functions only changes the file management information and does not completely delete the data from your mobile storage device. When disposing of or transferring a mobile storage device, Siemens strongly recommends physically destroying it or completely deleting data from the mobile storage device by using a commercially available computer data erasing software.

REACH/RoHS Declaration

You can find our current **REACH/RoHS** declarations at:

<https://www.siemens.com/global/en/home/products/energy/ecotransparency/ecotransparency-downloads.html>

NOTE: You can find more information about activities and programs to protect the climate at the EcoTransparency website:

<https://www.siemens.com/global/en/home/products/energy/ecotransparency.html>

Section 2: Equipment Operating Conditions

General Safety Precautions



Current Transformer Circuits

The secondary circuit of a live CT must not be open circuited. Non-observance of this precaution can result in injury to personnel or damage to equipment.



External Resistors

Where external resistors are fitted to relays, these may present a danger of electric shock or burns, if touched.



Fibre Optic Communication

Where fibre optic communication devices are fitted, these should not be viewed directly. Optical power meters should be used to determine the operation or signal level of the device.



Front Cover

The front cover provides additional securing of the relay element within the case. The relay cover should be in place during normal operating conditions.



Disposal

The Relay should be disposed of in a manner which does not provide a threat to health or the environment. All laws and regulations specific to the country of disposal should be adhered to.

The relays and protection systems manufactured under the Reyrolle brand currently do not come within the scope of either the European WEEE or RoHS directives as they are equipment making up a fixed installation.

Section 3: Dimensions and Panel Fixings

3.1 Relay Dimensions

Relays are supplied in size E8, E10 and E12 cases.

Panel cut-out requirements and case dimensions are shown below.

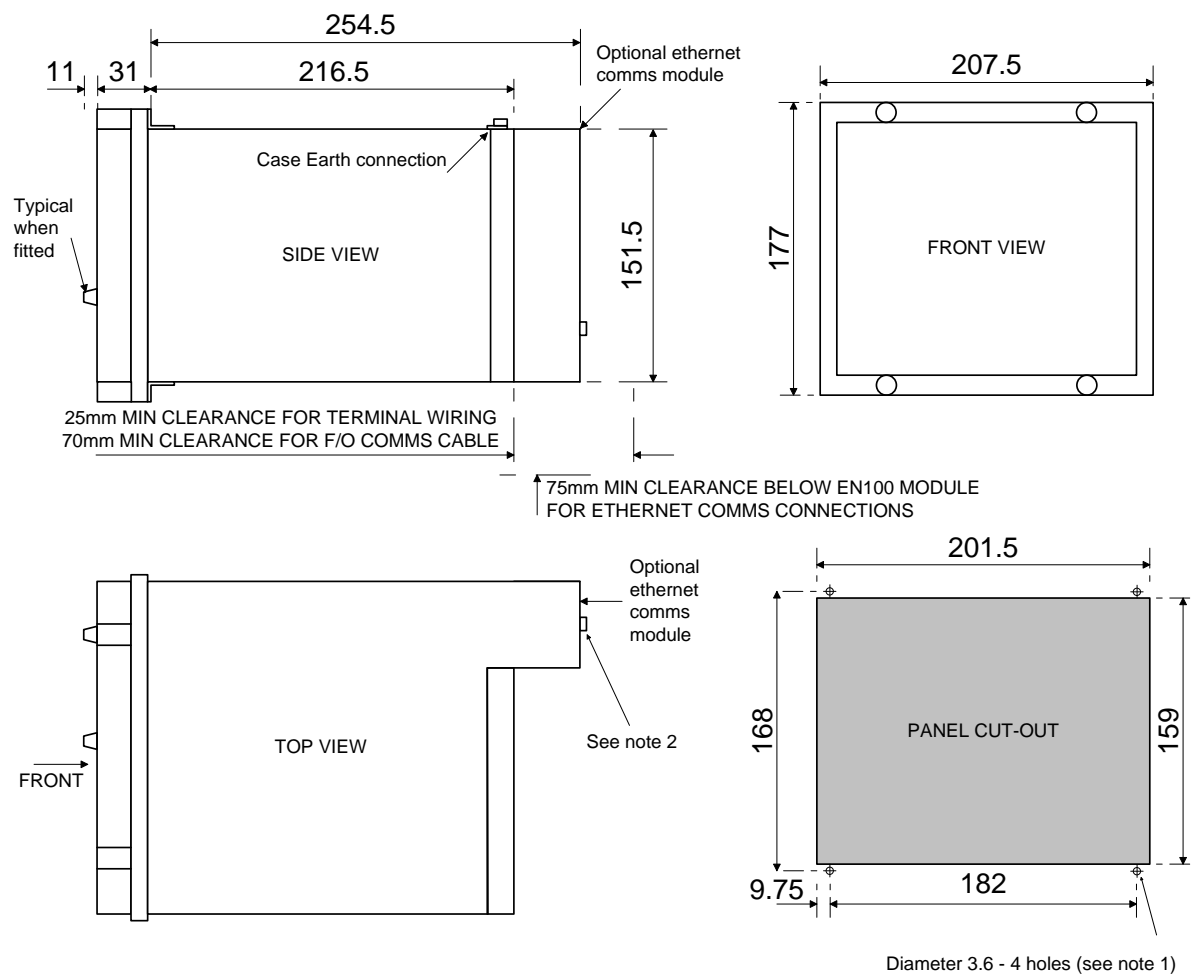

NOTES:

1) THE 3.6 HOLES ARE FOR M4 THREAD FORMING (TRILOBULAR) SCREWS. THESE ARE SUPPLIED AS STANDARD AND ARE SUITABLE FOR USE IN FERROUS / ALUMINIUM PANELS 1.6mm THICK AND ABOVE. FOR OTHER PANELS, HOLES TO BE M4 CLEARANCE (TYPICALLY 4.5 DIAMETER) AND RELAYS MOUNTED USING M4 MACHINE SCREWS, NUTS AND LOCKWASHERS (SUPPLIED IN PANEL FIXING KIT).

2) ACCESS CLEARANCE REQUIRED FOR OPTIONAL ETHERNET COMMS MODULE RETAINING SCREW

Figure 3.1-1 Overall Dimensions and panel Drilling for Size E8 Epsilon case

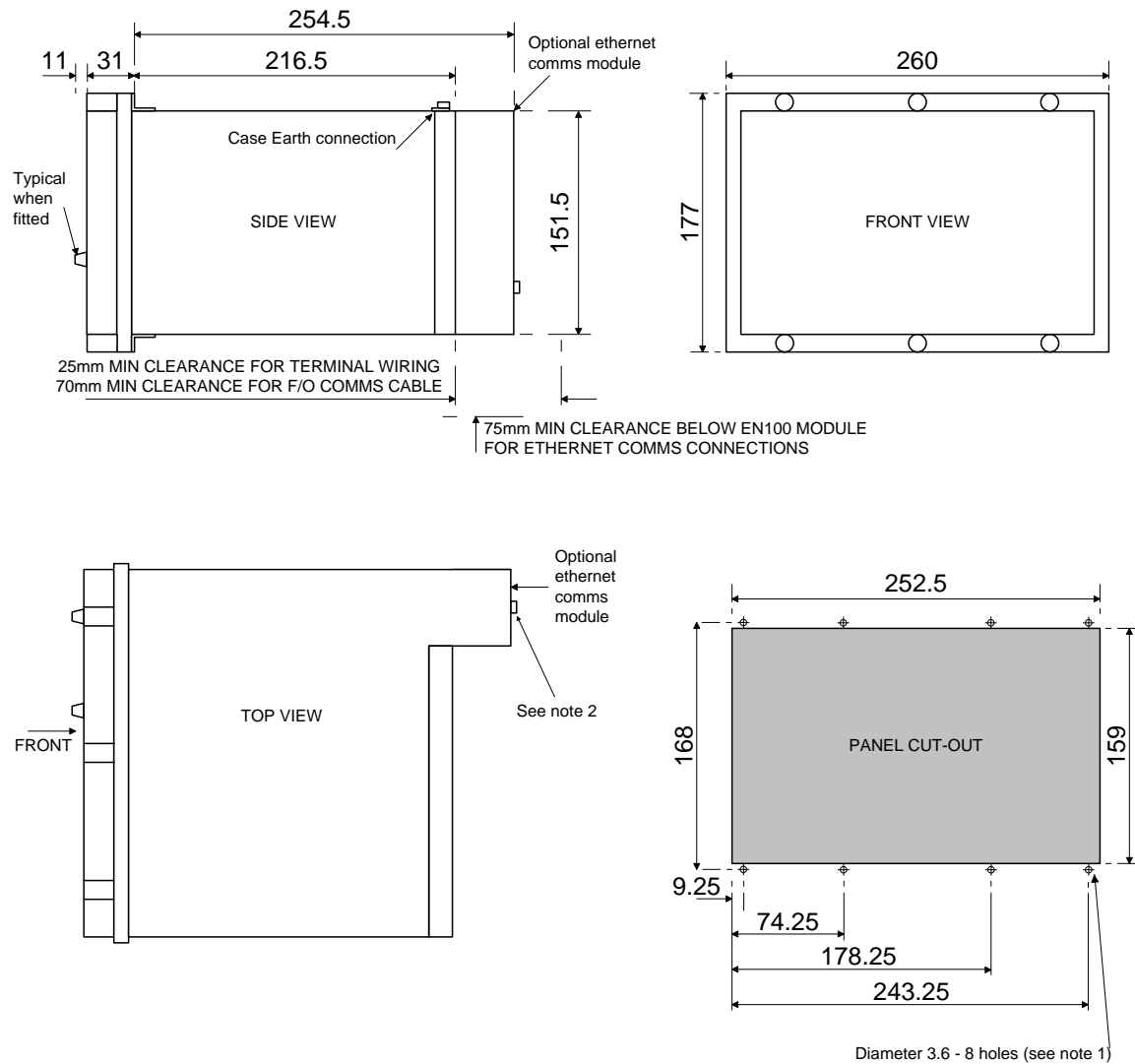

NOTES:

1) THE 3.6 HOLES ARE FOR M4 THREAD FORMING (TRILOBULAR) SCREWS. THESE ARE SUPPLIED AS STANDARD AND ARE SUITABLE FOR USE IN FERROUS / ALUMINIUM PANELS 1.6mm THICK AND ABOVE. FOR OTHER PANELS, HOLES TO BE M4 CLEARANCE (TYPICALLY 4.5 DIAMETER) AND RELAYS MOUNTED USING M4 MACHINE SCREWS, NUTS AND LOCKWASHERS (SUPPLIED IN PANEL FIXING KIT).

2) ACCESS CLEARANCE REQUIRED FOR OPTIONAL ETHERNET COMMS MODULE RETAINING SCREW

Figure 3.1-2 Overall Dimensions and panel Drilling for Size E10 Epsilon case

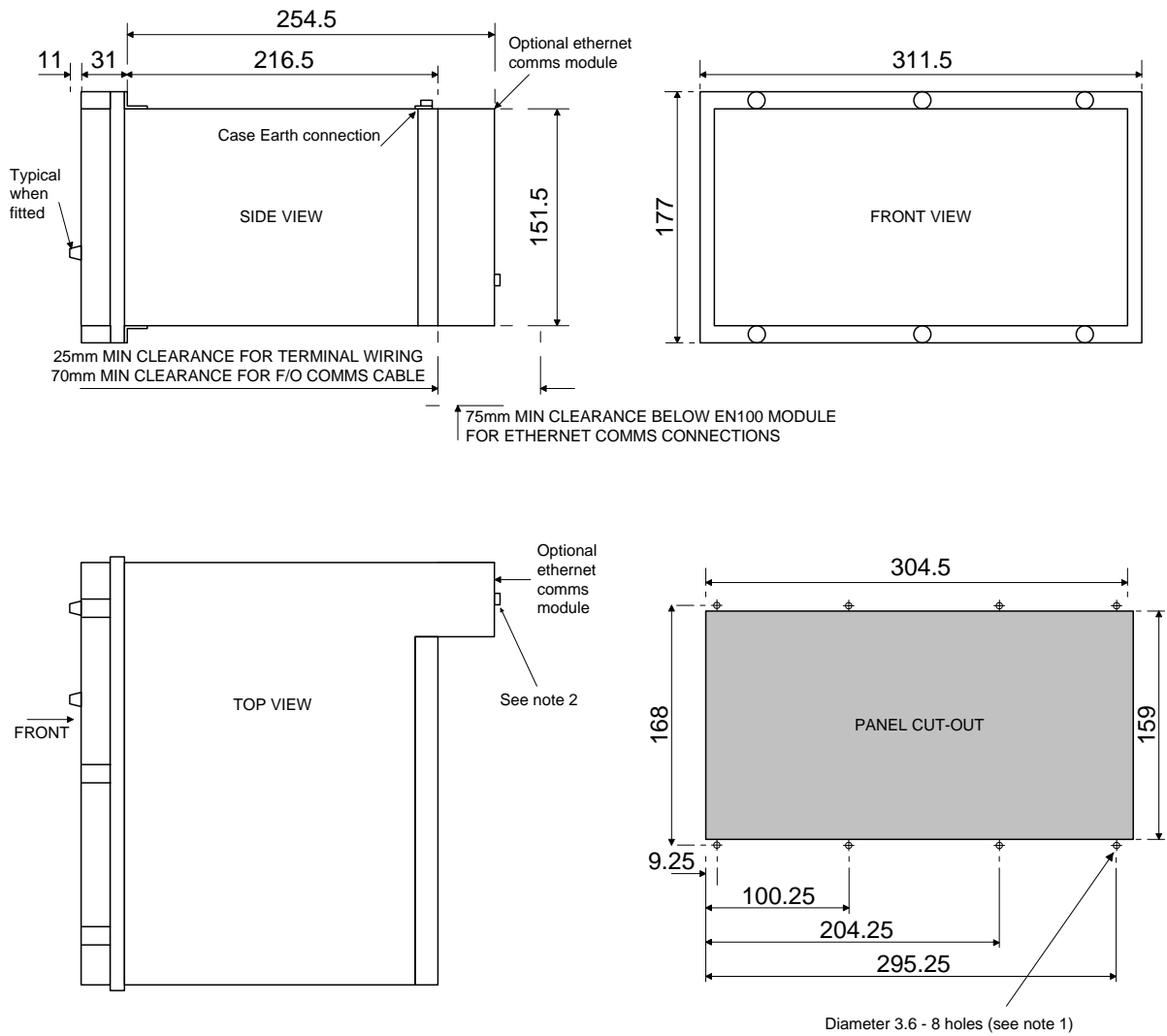

NOTES:

1) THE 3.6 HOLES ARE FOR M4 THREAD FORMING (TRILOBULAR) SCREWS. THESE ARE SUPPLIED AS STANDARD AND ARE SUITABLE FOR USE IN FERROUS / ALUMINIUM PANELS 1.6mm THICK AND ABOVE. FOR OTHER PANELS, HOLES TO BE M4 CLEARANCE (TYPICALLY 4.5 DIAMETER) AND RELAYS MOUNTED USING M4 MACHINE SCREWS, NUTS AND LOCKWASHERS (SUPPLIED IN PANEL FIXING KIT).

2) ACCESS CLEARANCE REQUIRED FOR OPTIONAL ETHERNET COMMS MODULE RETAINING SCREW

Figure 3.1-3 Overall Dimensions and panel Drilling for Size E12 Epsilon case

3.2 Fixings

3.2.1 Crimps

M4 Ring tongued crimps with 90° bend are recommended for connection to the standard M4 terminal screws and RS485 port connections.

3.2.2 Panel Fixings

Typical mounting screw kit per Relay)

Consists of 4 off M4x10mm Screws

4 off M4 Nuts

4 off M4 Lock Washer

Typical rear terminal block fixing kit (1kit per terminal block fitted to relay) Consists of:

28 x M4, 8mm Screws

28 x M4 Lock Washer

Section 4: Rear Terminal Drawings

4.1 E8 CASE

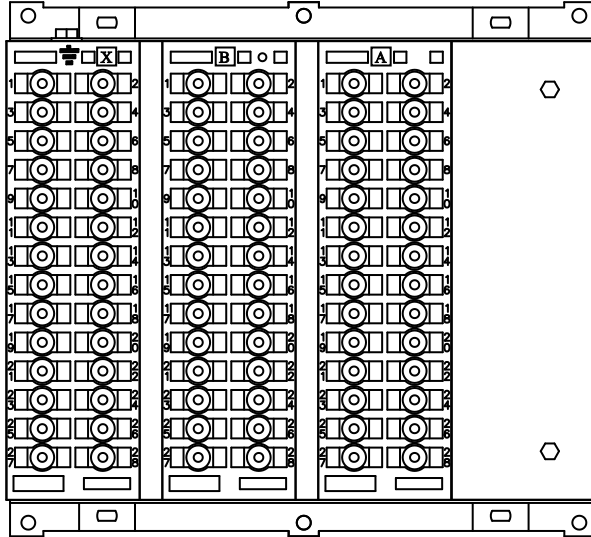

E8 STANDARD COMMS:- USB FRONT PORT,RS485 (SEE NOTE 2)

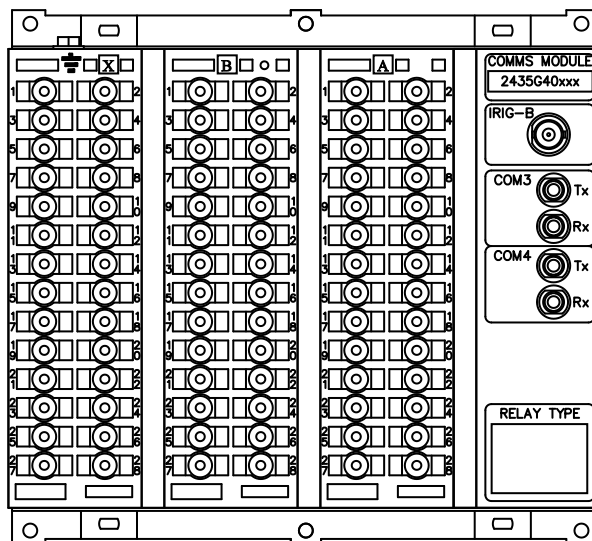

E8 STANDARD COMMS + ADDITIONAL PORTS

USB FRONT PORT, RS485 (SEE NOTE 2), 2 X F.O. (S.T. CONNECTORS), IRIG B

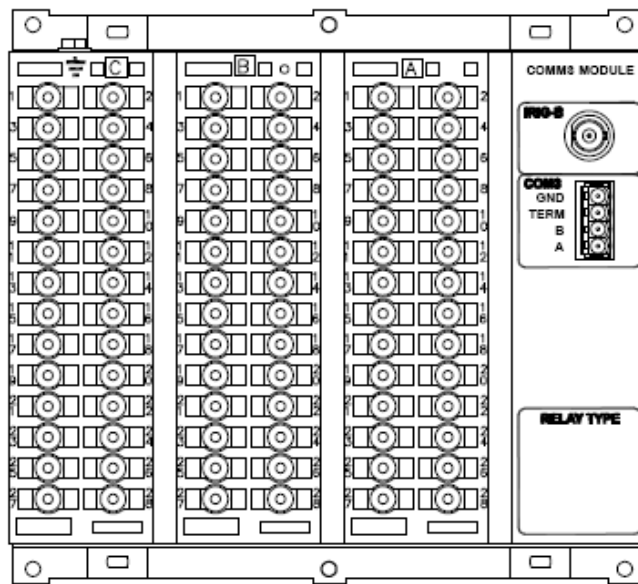

RELAY VIEWED FROM REAR

E8 STANDARD COMMS + ADDITIONAL PORTS

USB FRONT PORT, 2 x RS485 (SEE NOTE 2), IRIG B

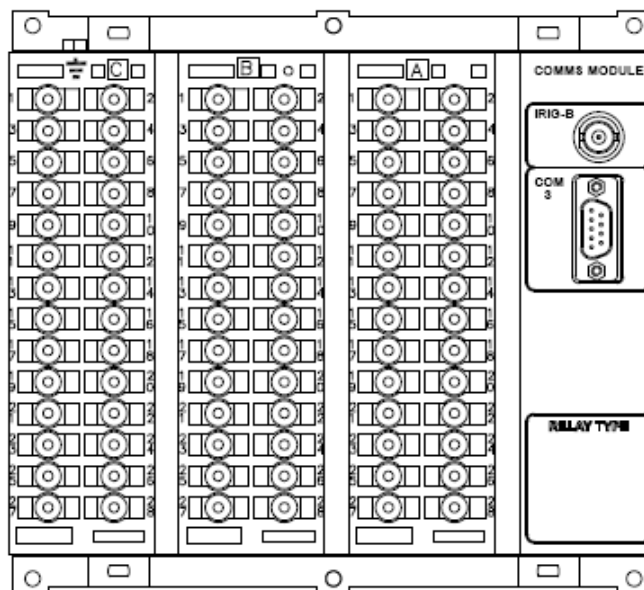

RELAY VIEWED FROM REAR

E8 STANDARD COMMS + ADDITIONAL PORTS

USB FRONT PORT, RS485 (SEE NOTE 2), RS232, IRIG B

Notes

- 1) Recommended terminations are pre-insulated & must be crimped using approved tooling.
- 2) RS485 (block "B" terminals 14, 16, 18, 20 and optional COMMS MODULE) connections are by screened, twisted pair RS485 compliant cable. When wiring to the relay ensure that these terminals are not obscured by other wiring runs.

4.2 E10 CASE

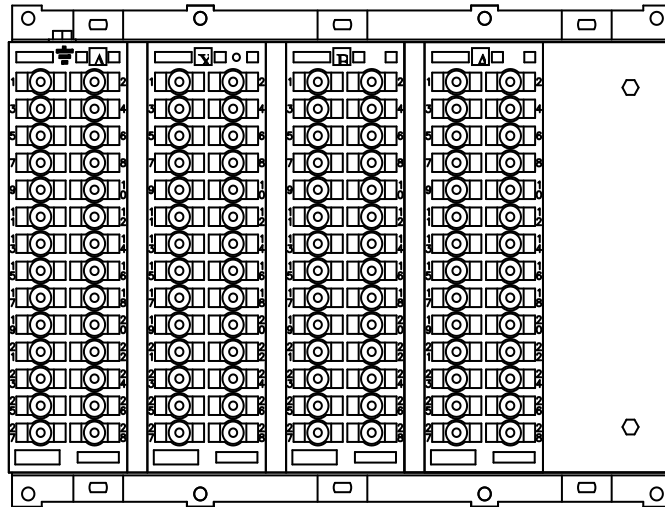

RELAY VIEWED FROM REAR

E10 STANDARD COMMS:- USB FRONT PORT,RS485 (SEE NOTE 2)

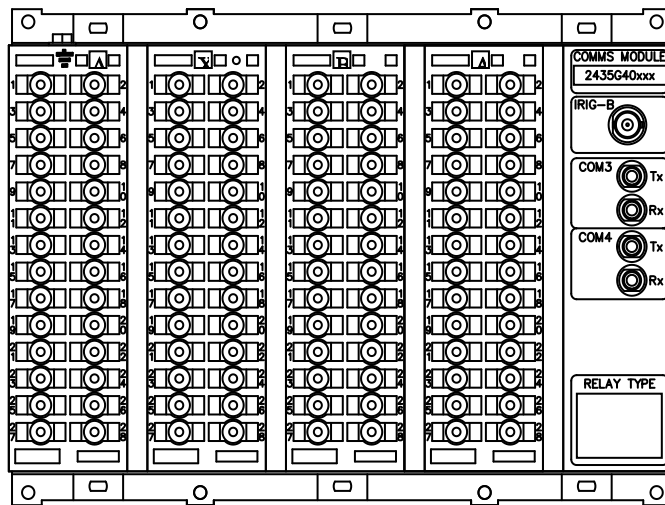

RELAY VIEWED FROM REAR

E10 STANDARD COMMS + ADDITIONAL PORTS

USB FRONT PORT, RS485 (SEE NOTE 2), 2 X F.O. (S.T. CONNECTORS), IRIG B

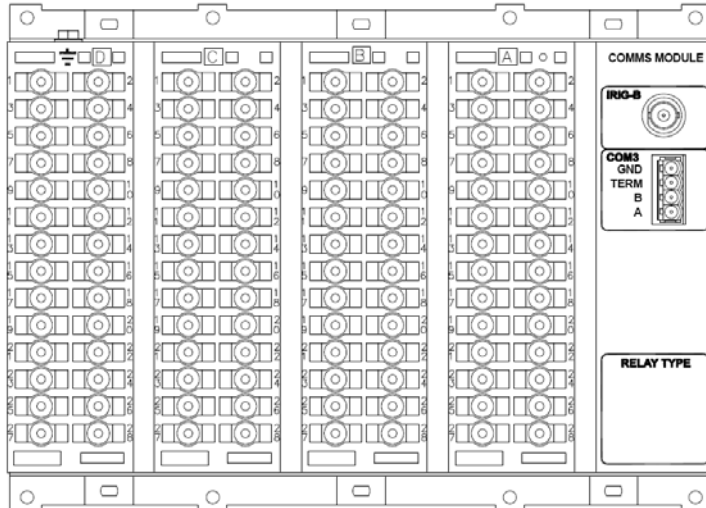

E10 STANDARD COMMS + ADDITIONAL PORTS

USB FRONT PORT, 2 x RS485 (SEE NOTE 2), IRIG B

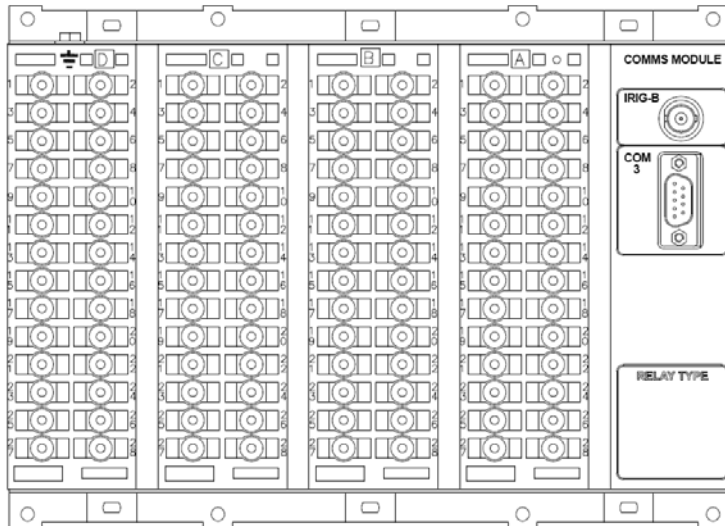

E10 STANDARD COMMS + ADDITIONAL PORTS

USB FRONT PORT, RS485 (SEE NOTE 2), RS232, IRIG B

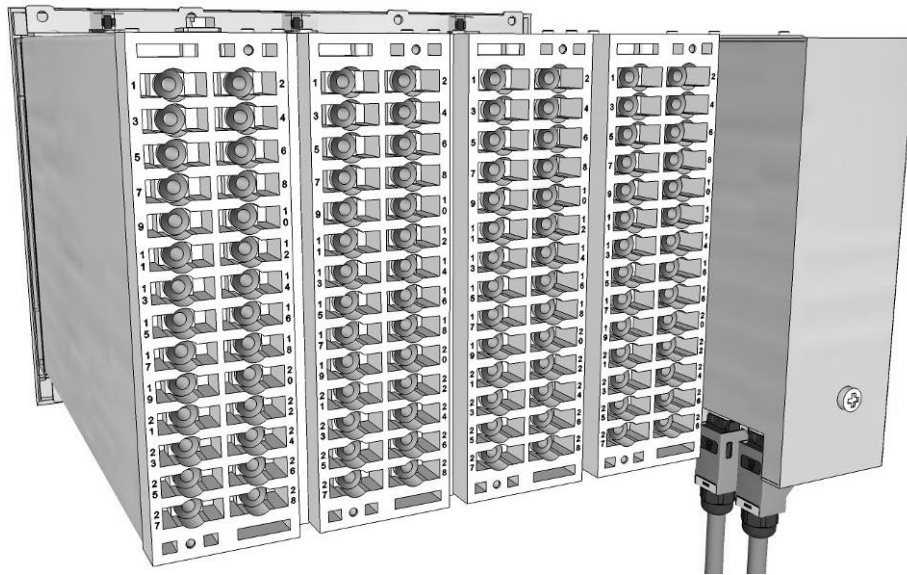
**E10 STANDARD COMMS + ADDITIONAL ETHERNET PORTS**

(RJ45 shown, Fibre optic LC similar)

Notes

- 1) Recommended terminations are pre-insulated & must be crimped using approved tooling.
- 2) RS485 (block "B" terminals 14, 16, 18, 20 and optional COMMS MODULE) connections are by screened, twisted pair cable.

Ensure that these terminals are not obscured by other wiring runs.

Cable should be RS485 compliant.

Section 5: Connection/Wiring/Diagrams

5.1 Wiring Diagram: 7SR242 Relay

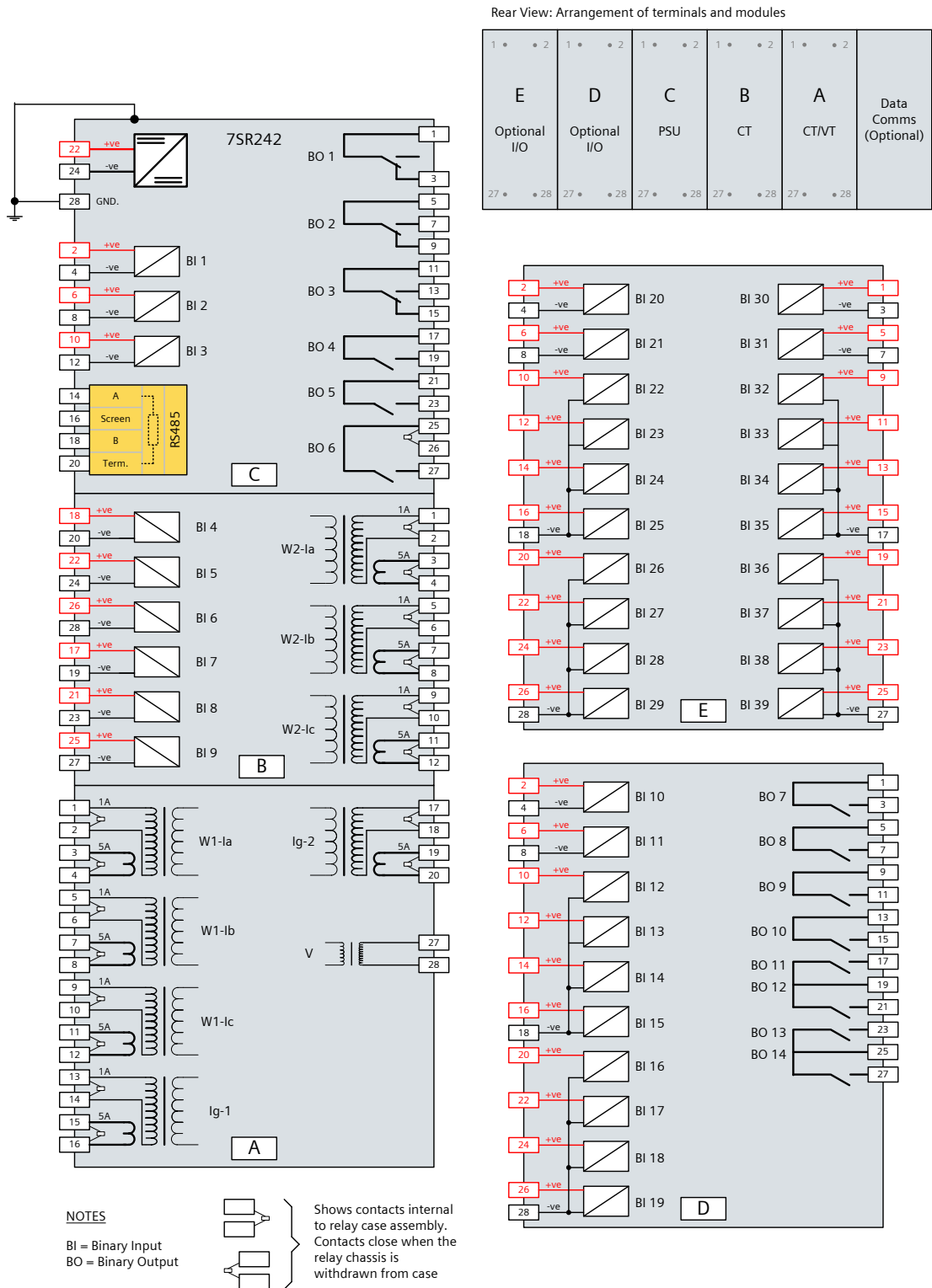

Figure 5.1-1 7SR242 Wiring Diagram

Section 6: Data Comms Connections

6.1 RS485 Connection

The RS485 communication port terminals are located on the rear of the relay and can be connected using a suitable RS485 120Ω screened twisted pair cable.

The RS485 electrical connection can be used in a single or multi-drop configuration. When used with Reydisp the RS485 master must support and use the Auto Device Enable (ADE) feature.

The last device in the connection must be terminated correctly in accordance with the master driving the connection. A terminating resistor is fitted in each relay, when required this is connected in circuit using an external wire loop between terminals 18 and 20 of the power supply module.

Up to 64 relays can be connected to the RS485 bus.

Each relay has an internal terminating resistor – this can be connected in circuit where necessary.

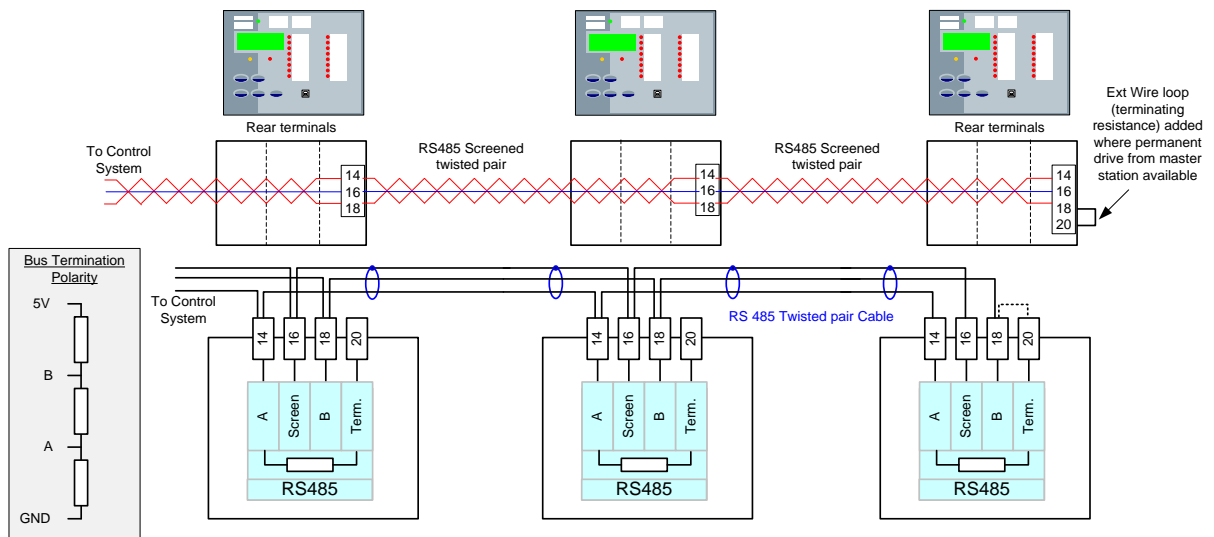

Figure 6.1-1 RS485 Data Comms Connections

6.2 IRIG-B Connections

A BNC plug is provided to connect a co-axial cable carrying IRIG-B time synchronisation signals. The length of the stub should be minimised by connecting the tee-connector directly to the rear of the relay. A suitable co-axial cable would be type RG 58 50ohms.

6.3 Optional Fibre Optic Connections

Where fitted rear Data Comms ports 3 and 4 comprise Fibre–Optic ST™ (BFOC/2.5) bayonet connectors-4 per product. 62.5 / 125µm glass fibre is recommended for all lead lengths.

When installing fibre, ensure that the fibres' bend radii comply with the recommended minimum for the fibre used- typically 50mm is acceptable.

The fibre optic data comms link will be interrupted if the relay element is withdrawn from the case.

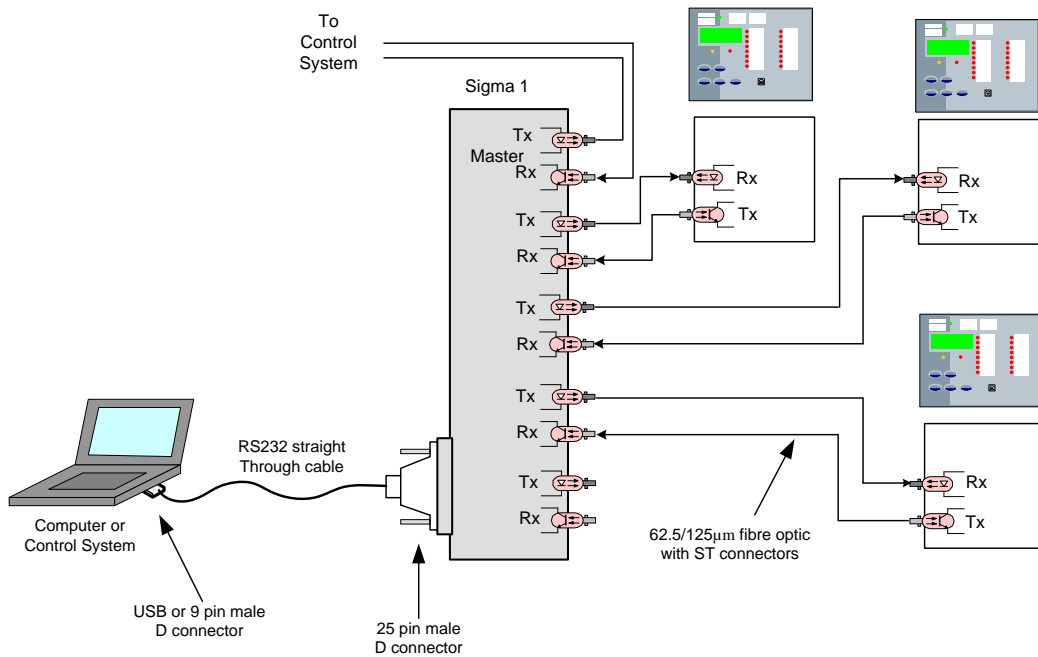

Figure 6.3-1 Data Comms to Multiple Devices Using Sigma 1 and F.O. Star Network

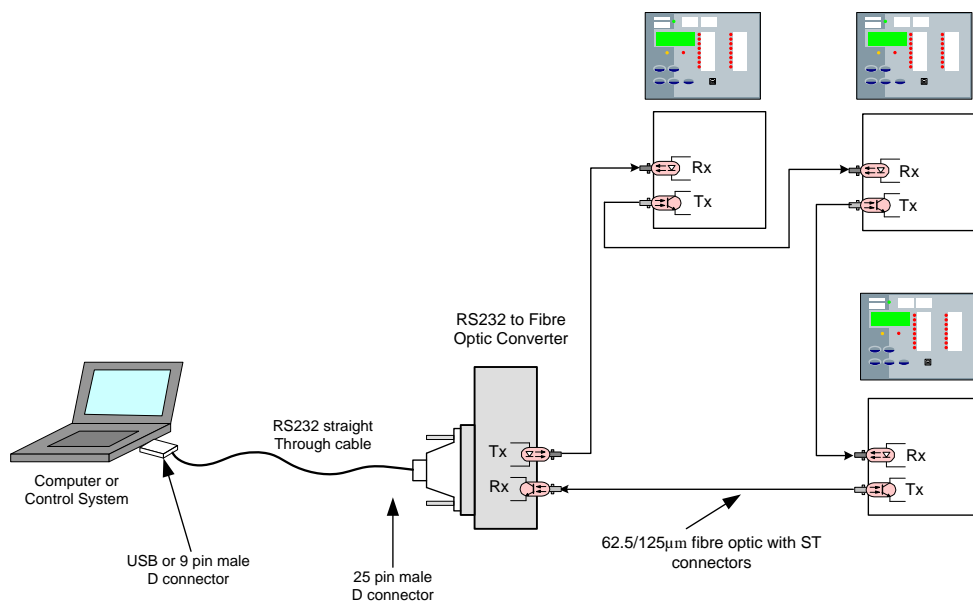

Figure 6.3-2 Data Comms to Multiple Devices Using Sigma 3 and F.O. Ring Network

6.4 Optional Additional RS485 Connections

The additional (optional) RS485 communication port is located at the rear of the relay and can be connected using a suitable RS485 120 ohm screened twisted pair cable.

The RS485 electrical connection can be used in a single or multi-drop configuration. When used with Reydisp the RS485 master must support and use the Auto Device Enable (ADE) feature.

The last device in the connection must be terminated correctly in accordance with the master device driving the connection. The relays are fitted with an internal terminating resistor which can be connected between the A and B by fitting an external wire loop between terminals 18 and 20 on the power supply module.

6.5 Optional RS232 Connections

The additional (optional) RS232 (9 pin plug) (DTE) communication port is located at the rear of the relay and can be connected using a suitable RS232 cable.

Where there is a requirement for multi-drop RS232 connection, a suitable device to facilitate this should be obtained.

Pin	Relay Function
1	Not Connected
2	Receive Data (RXD)
3	Transmit Data (TXD)
4	Output Supply +5V 50mA
5	Signal Ground (GND)
6	Output Supply +5V 50mA
7	Linked to 8 (volts free)
8	Linked to 7 (volts free)
9	Output Supply +5V 50mA

Figure 6.5-1 RS232 Data Comms Pin Connections

6.6 Additional (Optional) Ethernet Connection for IEC 61850

Rear Ethernet Comms port Ch 1 and Ch 2 comprises Fibre–Optic Duplex LC connectors or electrical RJ45 connectors.

When installing fibre, ensure that the fibres' bend radii comply with the recommended minimum for the fibre used—typically 50mm is acceptable, 62.5 / 125µm glass fibre is recommended for all distances.

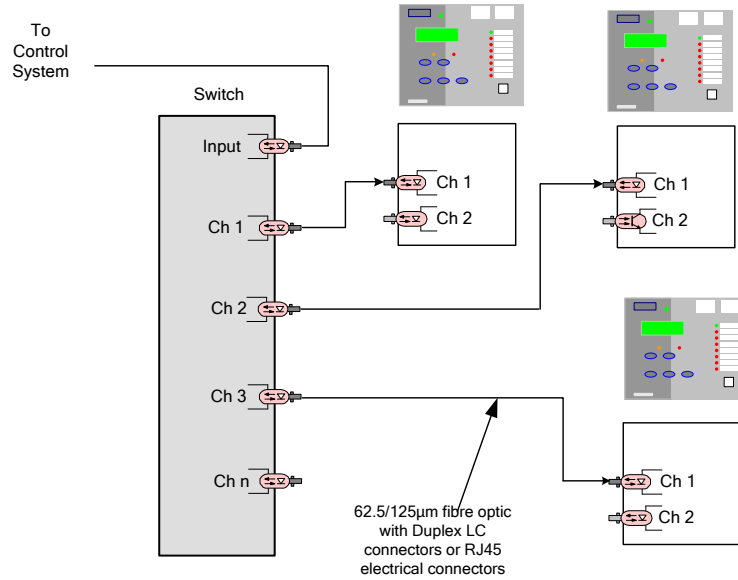

Figure 6.6-1 Ethernet connection for IEC 61850 (star connection)

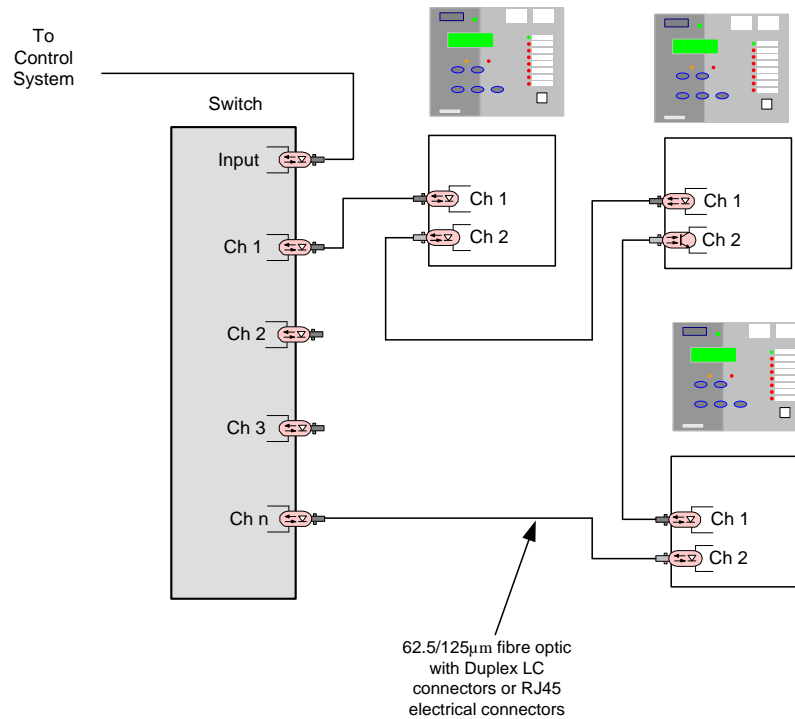

Figure 6.6-2 Ethernet connection for Fibre Optic IEC 61850 (ring connection)

6.7 Ethernet Network Redundancy IEC 61850

The EN100+ module is used on current Reyrolle devices (from 7SR242 hardware /DD) to provide Ethernet/IEC61850 functionality and supports RSTP, PRP and HSR redundancy protocols.

Earlier 7SR242 (/CC) devices were manufactured with the EN100 (not EN100+) module and the electrical version cannot support redundancy. The optical version can support PRP and HSR redundancy if firmware is updated to version 4.2 or later and FPGA is updated to version 515 or later. Earlier 7SR242 devices do not support the EN100+ module and cannot be updated by simply exchanging the EN100 module.

All current 7SR242 IEC61850 variants are delivered with the EN100+ (Plus) module and firmware 4.24 or later.

The EN100 module firmware and FPGA can be updated by connecting to the relay via the rear Ethernet port. For more information on connecting to the relay via the Ethernet port, please see the Reydisp Manager Userguide or the Guidance Note available from the product website. Depending on the EN100 module type and Firmware version, the following protocol options are available,

Interface Type	EN100 Firmware	Line Mode	Switch Mode			
			RSTP	OSM	PRP	HSR
Electrical RJ45 EN100+	4.21and later	✓	✓	✓	✓	✓
Optical EN100+	4.21and later	✓	✓	✓	✓	✓
Electrical RJ45 EN100+	4.08 or earlier	✓	✓	✓	x	x
Optical EN100+	4.08 or earlier	✓	✓	✓	x	x
Electrical RJ45 EN100	4.21and later	✓	x	x	x	x
Optical EN100	4.21and later	✓	✓	✓	✓	✓
Electrical RJ45 EN100	4.08 or earlier	✓	x	x	x	x
Optical EN100	4.08 or earlier	✓	✓	✓	x	x

Table 1: EN100 Redundancy availability

6.7.1 RSTP – Rapid Spanning Tree Protocol

RSTP is a redundancy protocol with a minimal response time that has been standardized in IEEE-802.1D (2004). The reconfiguration time depend on the topology and start at 50ms.

RSTP need to be enabled on the device within Reydisp Manager (See Reydisp Manager userguide). Network rings with up to 30 devices is possible.

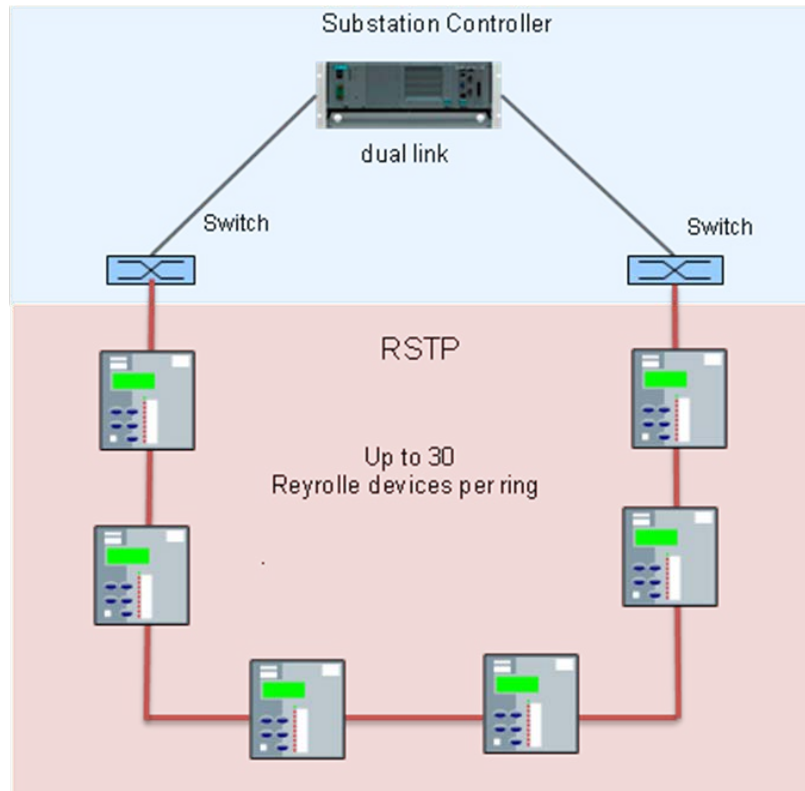

Figure 6.7-1 RSTP Ethernet Network Ring Configuration

6.7.2 PRP – Parallel Redundancy Protocol

The HSR redundancy protocol according to the IEC 62439-3 standard is based on double transmission of message frames over ring-topology networks in both directions. In the case of an error, the message frame will be transmitted without any delay. No reconfiguration time is necessary for the network, as is the case for RSTP.

PRP need to be enabled on the device within Reysdisp Manager (See Reysdisp Manager userguide).

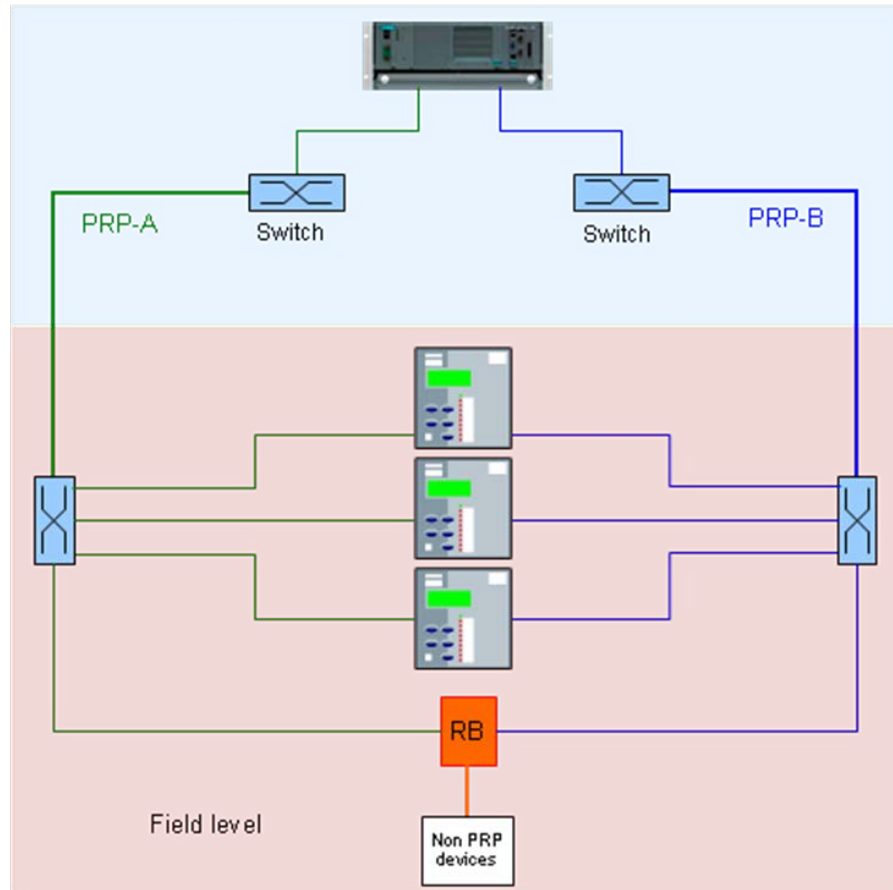

Figure 6.7-2 PRP Ethernet Network Configuration

6.7.3 HSR – High Availability Seamless Redundancy Protocol

The HSR redundancy protocol according to the IEC 62439-3 standard is based on double transmission of message frames over ring-topology networks in both directions. In the case of an error, the message frame will be transmitted without any delay. No reconfiguration time is necessary for the network.

HSR needs to be enabled on the device within Reydisp Manager (See Reydisp Manager user guide). Network rings with up to 50 devices is possible.

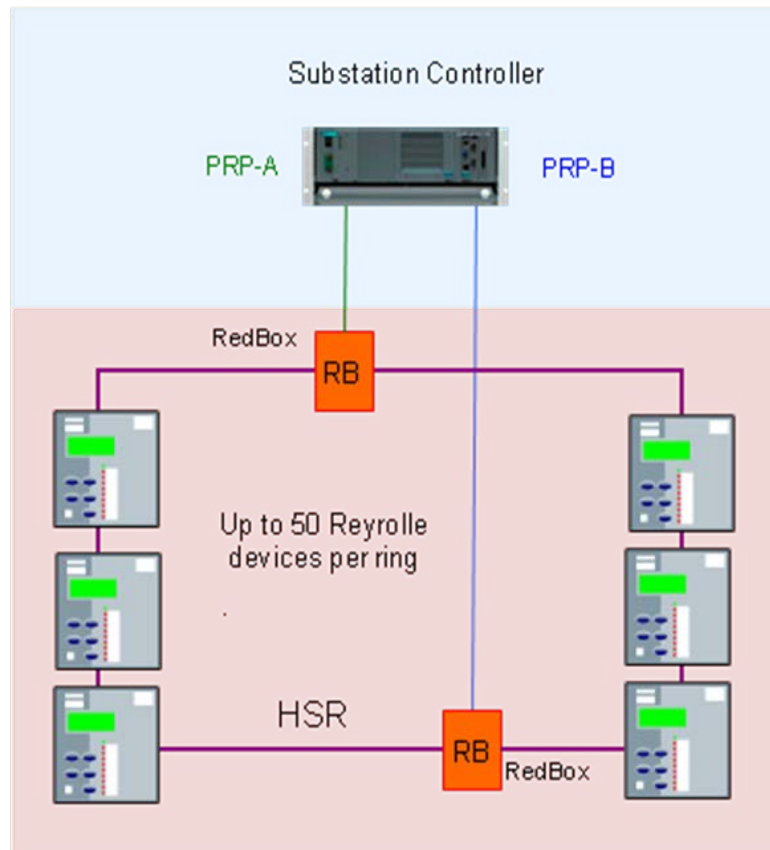

Figure 6.7-3 HSR Ethernet Network Ring Configuration

Section 7: Connection Diagrams

7.1 Typical AC Connections: 7SR242

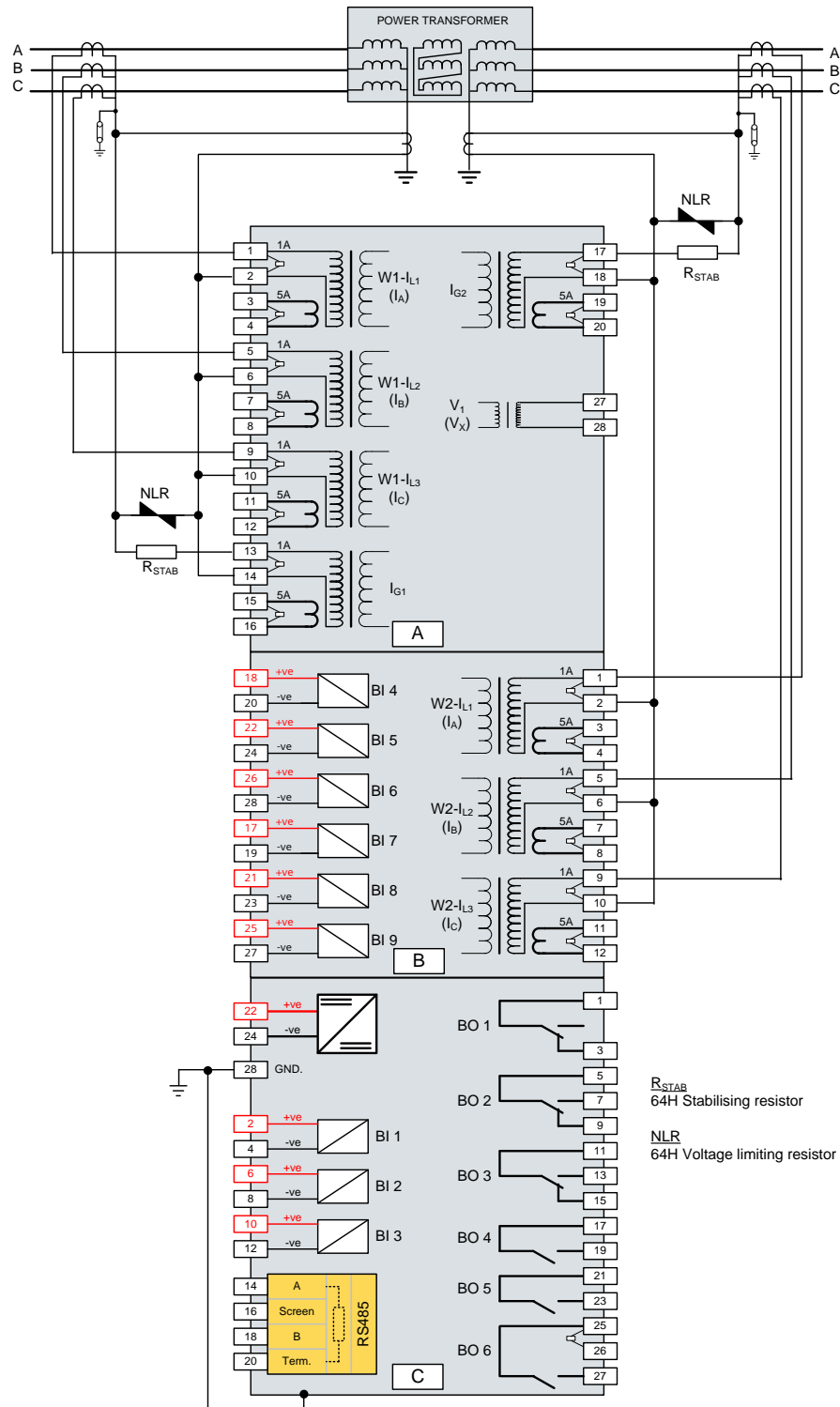

Figure 7.1-1 7SR24 Typical Connections

7SR242 Duobias

Multi-Function 2-Winding Transformer Protection Relay

Commissioning and Maintenance

Document Release History

This document is issue 2017/12. The list of revisions up to and including this issue is:

2017/12	Software release 2662H85001 R8e-7e
2017/08	Software release 2662H85001R8C-7b
2013/01	Software revision 2662H85001 R7c-7b
2012/08	Addition of optional IEC 61850 communication protocol and Ethernet Interface.
2010/06	Defect Report Form revised
2010/02	Document reformat due to rebrand
2010/02	Third issue. Software revision 2662H80001 R4c-3
2008/07	Second issue. Software revision 2662H80001R3d-2c.
2008/05	First issue

The copyright and other intellectual property rights in this document, and in any model or article produced from it (and including any registered or unregistered design rights) are the property of Siemens Protection Devices Limited. No part of this document shall be reproduced or modified or stored in another form, in any data retrieval system, without the permission of Siemens Protection Devices Limited, nor shall any model or article be reproduced from this document unless Siemens Protection Devices Limited consent.

While the information and guidance given in this document is believed to be correct, no liability shall be accepted for any loss or damage caused by any error or omission, whether such error or omission is the result of negligence or any other cause. Any and all such liability is disclaimed.

Contents

Commissioning and Maintenance	1
Document Release History.....	1
Contents	3
Section 1: Common Functions	7
1.1 Overview	7
1.2 Before Testing.....	7
1.2.1 Safety	7
1.2.2 Sequence of Tests	7
1.2.3 Test Equipment	8
1.2.4 Precautions	8
1.2.5 Applying Settings	9
1.3 Tests	10
1.3.1 Inspection	10
1.3.2 Secondary Injection Tests.....	10
1.3.3 Primary Injection Tests.....	10
1.3.4 Putting into Service	10
1.4 AC Energising Quantities.....	11
1.5 Binary Inputs	12
1.6 Binary Outputs	13
1.7 Relay Case Shorting Contacts.....	13
Section 2: Protection Functions	15
2.1 Biased Differential (87BD, 87HS)	17
2.1.1 Secondary Injection Testing.....	17
2.1.2 Primary Injection Testing.....	20
2.1.3 Phase Overcurrent (50, 51).....	21
2.1.4 Definite Time Overcurrent (50)	22
2.1.5 Inverse Time Overcurrent (51).....	22
2.2 Derived Earth fault (50N,51N).....	24
2.2.1 Definite Time Overcurrent (50N).....	25
2.2.2 Inverse Time Overcurrent (51N)	25
2.2.3 ANSI Reset.....	26
2.3 Measured Earth fault (50G, 51G).....	27
2.3.1 Definite Time Overcurrent (50G).....	28
2.3.2 Inverse Time Overcurrent (51G)	28
2.3.3 ANSI Reset.....	29
2.4 Restricted Earth fault (64H)	30
2.5 Open Circuit (46BC).....	32
2.6 Negative Phase Sequence Overcurrent (46NPS)	34
2.6.1 Definite Time NPS Overcurrent (46DT)	35
2.6.2 Inverse Time NPS Overcurrent (46IT)	35
2.7 Undercurrent (37, 37G).....	37
2.7.1 37-n Elements	37
2.7.2 37G-n Elements	38
2.8 Thermal Overload (49).....	39
2.9 Under/Over Voltage (27/59).....	41
2.9.2 Undervoltage Guard (27/59UVG)	43
2.10 Neutral Over Voltage (59N)	44
2.10.1 Definite Time (59NDT)	45
2.10.2 Inverse Time (59NIT)	45

2.11 Under/Over Frequency (81)	46
2.12 Overfluxing (24)	48
2.12.1 definite time (24DT).....	48
2.12.2 inverse time (24IT)	49
Section 3: Supervision Functions	51
3.1 CB Fail (50BF)	51
3.2 Trip/Close Circuit Supervision (74TCS, 74CCS)	53
3.3 Magnetising Inrush Detector (81HBL2)	54
3.4 Overfluxing Detector (81HBL5).....	56
Section 4: Control & Logic Functions	57
4.1 Quick Logic	57
Section 5: Testing and Maintenance	59
5.1 Periodic Tests	59
5.2 Maintenance.....	59
5.3 Troubleshooting	60
Section 6: Relay Software Upgrade Instructions	61
6.1 General	61
6.2 Replacing firmware on a product installed on site	61
6.2.1 Identify Which Software Is Currently Loaded.....	61
6.2.2 Overall Software Information.....	61
6.2.3 Product Configuration Information	61
6.2.4 Things To Do Before Loading New Firmware/Software	62
6.2.5 Loading Firmware using front USB port.....	62
6.2.6 Solving Software Upload Problems	62

List of Figures

Figure 2-1 Biased Differential.....	17
Figure 2-2 Secondary Injection using a Variac	18
Figure 2-3 Phase Overcurrent.....	21
Figure 2-4 Measured Earth Fault	24
Figure 2-5 Measured Earth Fault	27
Figure 2-6 Restricted Earth Fault	30
Figure 2-7 Open Circuit	32
Figure 2-8 Negative Phase Sequence Overcurrent	34
Figure 2-9 Undercurrent	37
Figure 2-10 Thermal Overload	39
Figure 2-11 Phase Under/Over Voltage	41
Figure 2-12 Neutral Overvoltage	44
Figure 2-13 Under/Over Frequency	46
Figure 2-14 Under/Over Frequency	48
Figure 3-1 CB Fail	51
Figure 3-2 Trip Circuit Supervision.....	53
Figure 3-3 Magnetising Inrush Detector	54
Figure 3-4 Magnetising Inrush Detector	56

Section 1: Common Functions

1.1 Overview

Commissioning tests are carried out to prove:

- a) Equipment has not been damaged in transit.
- b) Equipment has been correctly connected and installed.
- c) Prove characteristics of the protection and settings which are based on calculations.
- d) Confirm that settings have been correctly applied.
- e) To obtain a set of test results for future reference.

1.2 Before Testing

1.2.1 Safety

The commissioning and maintenance of this equipment should only be carried out by skilled personnel trained in protective relay maintenance and capable of observing all the safety precautions and regulations appropriate to this type of equipment and also the associated primary plant.

Ensure that all test equipment and leads have been correctly maintained and are in good condition. It is recommended that all power supplies to test equipment be connected via a Residual Current Device (RCD), which should be located as close to the supply source as possible.

The choice of test instrument and test leads must be appropriate to the application. Fused instrument leads should be used when measurements of power sources are involved, since the selection of an inappropriate range on a multi-range instrument could lead to a dangerous flashover. Fused test leads should not be used where the measurement of a current transformer (C.T.) secondary current is involved, the failure or blowing of an instrument fuse or the operation of an instrument cut-out could cause the secondary winding of the C.T. to become an open circuit.

Open circuit secondary windings on energised current transformers are a hazard that can produce high voltages dangerous to personnel and damaging to equipment, test procedures must be devised so as to eliminate this risk.

1.2.2 Sequence of Tests

If other equipment is to be tested at the same time, then such testing must be co-ordinated to avoid danger to personnel and/or equipment.

When all cabling and wiring is completed, a comprehensive check of all terminations for tightness and compliance with the approved diagrams must be carried out. This can then be followed by the insulation resistance tests which, if satisfactory allows the wiring to be energised by either the appropriate station supply or test supply.

When primary injection tests are completed satisfactorily, all remaining systems can be functionally tested before the primary circuit is energised. Some circuits may require further tests before being put on load.

Protection relay testing will require access to the protection system wiring diagrams, relay configuration information and protection settings. The following sequence of tests is loosely based on the arrangement of the relay menu structure. A test log based on the actual tests completed should be recorded for each relay tested. A typical example of this Site Test Sheet is included.

The 'Description of Operation' section of this manual provides detailed information regarding the operation of each function of the relay.

1.2.3 Test Equipment

Required test equipment is:

Secondary injection equipment with integral time interval meter

Primary injection equipment

A d.c. supply with nominal voltage within the working range of the relay's d.c. auxiliary supply rating

A d.c. supply with nominal voltage within the working range of the relay's d.c. binary input rating

Other equipment as appropriate to the protection being commissioned – this will be specified in the product specific documentation.

The secondary injection equipment should be appropriate to the protection functions to be tested. Additional equipment for general tests and for testing the communications channel is:

- Portable PC with appropriate interface equipment.
- Printer to operate from the above PC (Optional).

Use of PC to facilitate testing

The functions of ReyDisp Evolution (see Section 2: Settings and Instruments) can be used during the commissioning tests to assist with test procedures or to provide documentation recording the test and test parameters. One method is to clear both the waveform and event records before each test is started, then, after the test upload from the relay the settings, events and waveform files generated as a result of application of the test. These can then be saved off to retain a comprehensive record of that test.

Relay settings files can be prepared on the PC (offline) or on the relay before testing commences. These settings should be saved for reference and compared with the settings at the end of testing to check that errors have not been introduced during testing and that any temporary changes to settings to suit the test process are returned to the required service state.

A copy of the Relay Settings as a Rich Text Format (.rtf) file suitable for printing or for record purposes can be produced from ReyDisp as follows. From the *File* menu select *Save As*, change the file type to *Export Default/Actual Setting (.RTF)* and input a suitable filename.

When testing is completed the event and waveform records should be cleared and the settings file checked to ensure that the required in-service settings are being applied.

1.2.4 Precautions

Before electrical testing commences the equipment should be isolated from the current and voltage transformers. The current transformers should be short-circuited in line with the local site procedure. The tripping and alarm circuits should also be isolated where practical. The provision and use of secondary injection test sockets on the panel simplifies the isolation and test procedure.

Ensure that the correct auxiliary supply voltage and polarity is applied. See the relevant scheme diagrams for the relay connections.

Check that the nominal secondary current rating of the current and voltage transformers has been correctly set in the System Config menu of the relay.

1.2.5 Applying Settings

The relay settings for the particular application should be applied before any secondary testing occurs. If they are not available then the relay has default settings that can be used for pre-commissioning tests. See the Relay Settings section of this manual for the default settings.

Note that the tripping and alarm contacts for any function must be programmed correctly before any scheme tests are carried out.

The relay features multiple settings groups, only one of which is active at a time. In applications where more than one settings group is to be used it may be necessary to test the relay in more than one configuration.

Note. One group may be used as a 'Test' group to hold test-only settings that can be used for regular maintenance testing, eliminating the need for the Test Engineer to interfere with the actual in-service settings in the normally active group. This Test group may also be used for functional testing where it is necessary to disable or change settings to facilitate testing.

When using settings groups it is important to remember that the relay need not necessarily be operating according to the settings that are currently being displayed. There is an 'active settings group' on which the relay operates and an 'edit/view settings group' which is visible on the display and which can be altered. This allows the settings in one group to be altered from the relay fascia while the protection continues to operate on a different unaffected group. The 'Active Settings Group' and the 'Edit Settings Group' are selected in the 'System Configuration Menu'.

The currently Active Group and the group currently Viewed are shown at the top of the display in the Settings display screen. If the View Group is not shown at the top of the display, this indicates that the setting is common to all groups. CT/VT ratio, I/O mapping and other settings which are directly related to hardware are common to all groups.

If the relay is allowed to trip during testing then the instruments display will be interrupted and replaced by the 'Trip Alert' screen which displays fault data information. If this normal operation interferes with testing then this function can be temporarily disabled for the duration of testing by use of the Trip Alert Enabled/Disabled setting in the System Config Menu.

After applying a settings change to the relay, which may involve a change to the indication and output contacts, the **TEST/RESET** key should be pressed to ensure any existing indication and output is correctly cleared.

1.3 Tests

1.3.1 Inspection

Ensure that all connections are tight and correct to the relay wiring diagram and the scheme diagram. Record any deviations. Check that the relay is correctly programmed and that it is fully inserted into the case. Refer to 'Section 2: Settings and Instruments' for information on programming the relay.

1.3.2 Secondary Injection Tests

Select the required relay configuration and settings for the application.

Isolate the auxiliary D.C. supplies for alarm and tripping from the relay and remove the trip and intertrip links.

Carry out injection tests for each relay function, as described in this document

For all high current tests it must be ensured that the test equipment has the required rating and stability and that the relay is not stressed beyond its thermal limit.

1.3.3 Primary Injection Tests

Primary injection tests are essential to check the ratio and polarity of the current transformers as well as the secondary wiring. Primary injection testing of the 87BD Biased Differential protection is recommended to avoid relay operation during first energisation of the transformer if incorrect values are applied to the *ICT Connection* protection setting.

Note. If the current transformers associated with the protection are located in power transformer bushings it may not be possible to apply test connections between the current transformer and the power transformer windings. Primary injection is needed however, to verify the polarity of the CTs. In these circumstances primary current must be injected through the associated power transformer winding. It may be necessary to short circuit another winding in order to allow current to flow. During these primary injection tests the injected current is likely to be small due to the impedance of the transformer.

Phase current transformer polarities and connections can be checked by examination of the relay Current Meters and Differential Meters in the Instruments Menu when the protected plant is carrying load but Earth Fault CT polarity can only be checked during primary injection.

1.3.4 Putting into Service

After tests have been performed satisfactorily the relay should be put back into service as follows:-

Remove all test connections.

Replace all secondary circuit fuses and links, or close m.c.b.

Ensure the Protection Healthy LED is on, steady, and that all LED indications are correct. If necessary press **CANCEL** until the Relay Identifier screen is displayed, then press **TEST/RESET** to reset the indication LEDs.

The relay meters should be checked in Instruments Mode with the relay on load

The relay settings should be downloaded to a computer and a printout of the settings produced. The installed settings should then be compared against the required settings supplied before testing began. Automated setting comparison can be carried out by ReyDisp using the *Compare Settings Groups* function in the *Edit* menu. Any modified settings will be clearly highlighted.

1.4 AC Energising Quantities

Voltage and current measurement for each input channel is displayed in the Instrumentation Mode sub-menus, each input should be checked for correct connection and measurement accuracy by single phase secondary injection at nominal levels. Ensure that the correct instrument displays the applied signal within limits of the Performance Specification.

	Applied Current								Applied Voltage
	W1-I _A	W1-I _B	W1-I _C	I _{G1}	W2-I _A	W2-I _B	W2-I _C	I _{G2}	V ₁ (V _X)
Secondary									
Primary									

Apply 3P balanced Current at nominal levels and ensure that the measured Zero Phase Sequence and Negative Phase Sequence quantities are approximately zero.

	ZPS	NPS
Current		

1.5 Binary Inputs

The operation of the binary input(s) can be monitored on the 'Binary Input Meters' display shown in 'Instruments Mode'. Apply the required supply voltage onto each binary input in turn and check for correct operation. Depending on the application, each binary input may be programmed to perform a specific function; each binary should be checked to prove that its mapping and functionality is as set as part of the Scheme Operation tests.

Where the pick-up timers associated with a binary input are set these delays should be checked either as part of the scheme logic or individually. To check a binary pick-up time delay, temporarily map the binary to an output relay that has a normally open contact. This can be achieved in the Output Matrix sub-menu by utilising the *BI n Operated* settings. Use an external timer to measure the interval between binary energisation and closure of the output contacts. Similarly, to measure the drop-off delay, map to an output relay that has a normally closed contact, time the interval between binary de-energisation and closure of the output contacts.

Note. The time measured will include an additional delay, typically less than 20ms, due to the response time of the binary input hardware, software processing time and the operate time of the output relay.

BI	Tested	DO Delay	Measured	PU Delay	Measured	Notes (method of initiation)
1						
2						
3						
4						
5						
6						
7						
8						
9						
10						
11						
12						
13						
14						
15						
16						
17						
18						
19						

1.6 Binary Outputs

A minimum of six output relays are provided. Two of these have change over contacts, BO2 & BO3, one has a normally closed contact, BO1 and the remainder have normally open contacts.

Care should be observed with regard to connected devices when forcing contacts to operate for test purposes. Short duration energisation can cause contact failure due to exceeding the break capacity when connected to inductive load such as electrically reset trip relays.

Close each output relay in turn from the ReyDisp Evolution PC programme, Relay – Control - Close output relay. This function will energise the output for its minimum operate time. This time is specified in the Output Config - Binary Output Config menu for each output relay and may be too short to measure with a continuity tester.

An alternative method of energising an output permanently so that wiring can be checked is to temporarily map the relay being tested to the 'Protection Healthy' signal in the Output Matrix, as this signal is permanently energised the mapped relay will be held energised, normally open contacts will be closed and vice versa.

BO	Checked	Notes (method of test)
1NC		
2NO		
2NC		
3NO		
3NC		
4		
5		
6		
7		
8		
9		
10		
11		
12		
13		
14		

1.7 Relay Case Shorting Contacts

CT inputs and terminals C25-C26 (Relay Withdrawn Alarm) are fitted with case mounted shorting contacts which provide a closed contact when the relay is withdrawn from the case. The operation of these contacts should be checked.

CT Shorting contacts checked	
Relay Withdrawn Alarm Checked	

Section 2: Protection Functions

This section details the procedures for testing each protection function of the 7SR24 relay. These tests are carried out to verify the accuracy of the protection pick-ups and time delays at setting and to confirm correct operation of any associated input and output functionality.

Guidance for calculating test input quantities is given in the relevant test description where required. In many cases it may be necessary to disable some functions during the testing of other functions, this prevents any ambiguity caused by the operation of multiple functions from one set of input quantities. The 'Function Config' Menu provides a convenient high level point at which all elements of a particular function can be Enabled/Disabled to suit testing. The 'Config' tab in 'ReyDisp Evolution' can be used to 'Enable/Disable' individual elements. Note that this screen disables functions by applying setting changes to the relay and that any changes must be sent to the relay to take effect and settings must be returned to their correct value after testing.

The table below indicates functions where function conflicts may occur during testing, consideration should be given to disabling functions to avoid interference.

Function Under Test	Biased Differential	Differential Highset	Phase Overcurrent	Derived E/F	Measured E/F	Restricted E/F	Open Circuit	NPS Overcurrent	Undercurrent	Thermal	U/O voltage	Neutral Overvoltage	U/O Frequency	Overfluxing	CB Fail	Trip cct Supervision	Inrush Detector	Overfluxing Detector
Biased Diff.		o	o	o	o	o	o	o	o	o					o			
Diff. Highset	o		o	o	o	o	o	o							o			
Phase OC	o	o		o	o		o	o	o	o					o			
Derived E/F	o	o	o		o	o	o	o	o	o					o			
Measured E/F	o	o	o	o		o	o	o	o	o					o			
Restricted E/F	o	o	o	o	o		o	o	o	o					o			
Open Circuit	o	o		o	o				o	o					o			
NPS OC	o	o		o	o	o			o	o					o			
Undercurrent	o		o	o	o	o	o	o							o			
Thermal	o		o	o	o	o	o	o							o			
U/O voltage												o	o	o	o			
Neutral OV											o			o	o			
U/O Frequency											o				o			
Overfluxing											o	o			o			
CB Fail	o	o	o	o	o	o	o	o	o	o	o	o	o	o				
74TCS/74CCS																		
Inrush Detector																		
O/fluxing Detector																		

The General Pickup LED can be used to assess operation of functions during testing if other functions are disabled or if the setting allocating General Pickup is temporarily modified.

Particular care should be taken when testing overcurrent functions that the thermal rating of the current inputs is not exceeded.

It should be considered that where several overlapping elements are used simultaneously, the overall protection operate time may be dependent on the operation of different individual elements at the various levels of applied current or voltage. The resulting composite characteristic may be tested by enabling all of the relevant applicable elements or the element operations can be separated or disabled and tested individually.

All relay settings should be checked before testing begins. It is recommended that the relay settings are extracted from the relay using ReyDisp Evolution software and a copy of these settings is stored for reference during and after testing. It may be necessary to disable some protection functions during the testing of other functions to allow unambiguous results to be obtained.

Care must be taken to reset or re-enable any settings that have been temporarily altered during the testing before the relay can be put into service. At the end of testing the relay settings should be compared to the file extracted at the start to ensure that errors have not been introduced.

An example 'Test Sheet' summary document is included at the end of this Guide.

2.1 Biased Differential (87BD, 87HS)

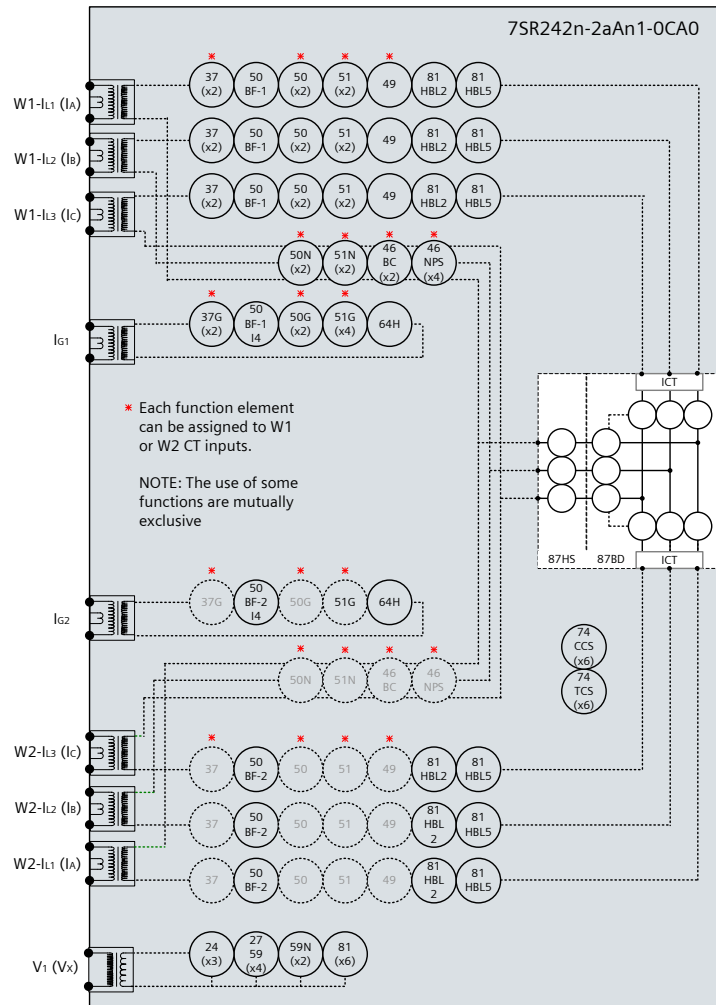

Figure 2-1 Biased Differential

Voltage Inputs:	None
Current Inputs:	W1-I _{L1} (I _A), W1-I _{L2} (I _B), W1-I _{L3} (I _C), and W2-I _{L1} (I _A), W2-I _{L2} (I _B), W2-I _{L3} (I _C),
Disable:	46, 49, 50, 51, 50N, 51N, 50BF,
Map Pickup LED:	87BD, 87HS - Self Reset

The differential elements are subjected to CT multipliers, Vector Group Compensation and Zero Sequence filters when applied to power transformers. The complexity of these features can cause confusion during testing and lead to incorrect relay settings being applied. It is recommended that the accuracy of the differential elements are tested by secondary injection with simplified differential settings applied to avoid ambiguity before reinstating the required site settings which can be tested more thoroughly by primary injection followed by final checking with the protected transformer on load.

2.1.1 Secondary Injection Testing

The settings used for Secondary Injection test purposes should be:

W1 ICT Multiplier	1x	W1 ICT
Connection	Yy0,0deg	W2 ICT
Multiplier	1x	W2 ICT
Connection	Yy0,0deg	

Secondary testing of the bias characteristic will be greatly simplified by the use of automated numeric protection test equipment such as the Omicron CMC256. This equipment can be programmed using setting which match those of the relay to test for accuracy over the whole operating range and give a clear easy to use graphical display of relay performance against the specified characteristic.

The relay characteristic can however be tested manually by recording a sequence of operating points for increasing levels of Restrain current. This can be achieved phase by phase using a single current source such as a Variac with two independently variable current limiting resistors as shown in figure 2-2 or from two independent single or three phase current sources. When two separate sources are used the phase of the two sinusoidal supplies must be the same and the Restrain and Operate currents must be calculated from the sum and difference of the two currents.

During manual testing the Operate and Restrain currents can be monitored on the relay in the Differential Meters in the Instruments menu.

For manual testing, the bias slope is usually checked for Restrain current up to 250% of nominal current. For testing above this level the continuous current rating of the relay inputs is likely to be exceeded, equipment or test procedure should be arranged in such a way that the short term thermal withstand of the relay current inputs is not exceeded during testing.

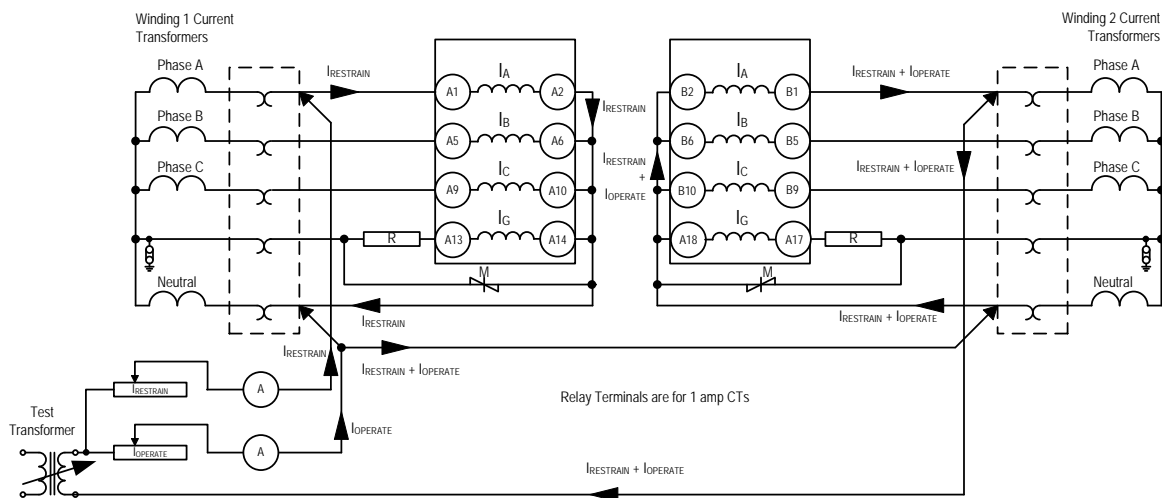

Figure 2-2 Secondary Injection using a Variac

2.1.1.1 Results for testing 87BD with a Variac

87BD INITIAL SETTING	87BD 1ST BIAS SLOPE SETTING	BIAS CURRENT ($\times I_N$) MEASURED ON AMMETER A1				
		0.00	1.00	1.50	2.00	2.50
		Operate Current Measured on Ammeter A2				
0.10	0.10	0.10	0.11	0.16	0.21	0.26
0.20	0.20	0.20	0.22	0.33	0.44	0.56
0.30	0.30	0.30	0.35	0.53	0.71	0.88
0.40	0.40	0.40	0.50	0.75	1.00	1.25
0.50	0.50	0.50	0.67	1.00	1.33	1.67
0.50	0.60	0.50	0.86	1.29	1.71	2.14
0.50	0.70	0.50	1.08	1.62	2.15	2.69
Selected Settings		Test Results				
		0.00	1.00	1.50	2.00	2.50
Phase A Pickup						
Phase B Pickup						
Phase C Pickup						

2.1.1.2 Results for testing 87BD with 2 current sources

87BD INITIAL SETTING	87BD 1ST BIAS SLOPE SETTING	W1 CURRENT (x I _N)				
		0.00	1.00	1.50	2.00	2.50
		W2 Current (x I _N)				
0.10	0.10	0.1	1.11	1.66	2.21	2.76
0.20	0.20	0.2	1.22	1.83	2.44	3.06
0.30	0.30	0.3	1.35	2.03	2.71	3.38
0.40	0.40	0.4	1.5	2.25	3.0	3.75
0.50	0.50	0.5	1.67	2.5	3.33	4.17
0.50	0.60	0.5	1.86	2.79	3.71	4.64
0.50	0.70	0.5	2.08	3.12	4.15	5.19
Selected Settings		Test Results				
		0.00	1.00	1.50	2.00	2.50
Phase A Pickup						
Phase B Pickup						
Phase C Pickup						

2.1.1.3 Differential Highset 87HS

Differential Highset can be tested by single phase secondary current injection. 87HS settings will usually be higher than the continuous thermal rating of the relay current inputs and equipment or test procedure should be arranged in such a way that the short term thermal withstand of the relay current inputs is not exceeded during testing. 50% of relay setting current can be injected into each of the 2 winding inputs simultaneously to achieve a differential current level of 100% if test current is limited by test equipment capacity.

The settings used for Secondary Injection test purposes should be:

W1 ICT Multiplier	1x
W1 ICT Connection	Yy0,0deg
W2 ICT Multiplier	1x
W2 ICT Connection	Yy0,0deg

These settings ensure a 1:1 ratio between the injected current and the relay setting. Note that operation of the element can be achieved at a lower level of current if a higher ICT multiplier setting is applied.

During testing the Operate current can be monitored on the relay in the Instruments menu.

2.1.2 Primary Injection Testing

Primary injection is recommended to prove the relay connections, CT polarity and settings before putting the protection scheme into service. Primary injection is essential to fully prove the connections of the Biased Differential and REF protections. To provide a useful test the relay should have the final site specific settings applied for primary injection tests.

WARNING!

It is important before carrying out any primary injection to ensure appropriate CTs are shorted to avoid operation of mesh corner or busbar type unit protection. If the injected primary current is large enough, the bus zones protection may operate.

Sufficient primary current to prove the connections and settings is required so that a minimum secondary current of about 10mA rms circulates in the relay inputs. This is difficult to achieve using high current primary injection equipment due to the relatively high impedance of the transformer windings. An alternative method is to apply 415 LVAC to one side of the transformer with a short circuit applied to the other side. The external three-phase primary short is usually applied to the HV side so that the LVAC supply is connected to the winding with lowest impedance which will result in a higher current level. The test current that will be produced can be predicted based on the impedance of the transformer and the applied test voltage. The primary test current is injected through all of the biased differential CT's on the LV side.

Injection of 3 phase current in this way will simulate balanced load conditions, or through fault. During injection, check that the W1 and W2 relay currents are in anti-phase by examination of the relay 'Differential Meters' in 'Instruments Mode'. Check each phase in turn, ensuring that the phase angle for 'W1 Relay' is in anti-phase with 'W2 Relay'.

When the transformer is eventually energised and carrying load current, the above examination of the W1 and W2 relay current phase angle should be re-checked for anti-phase to ensure that the correct *ICT Connection* settings are applied to the differential protection.

It should be noted that checking of Vector Grouping by phase alignment between W1 and W2 by 3 phase primary injection or on-load will highlight phase cross-over or connection polarity but will not show incorrect application of zero sequence filters.

2.1.3 Phase Overcurrent (50, 51)

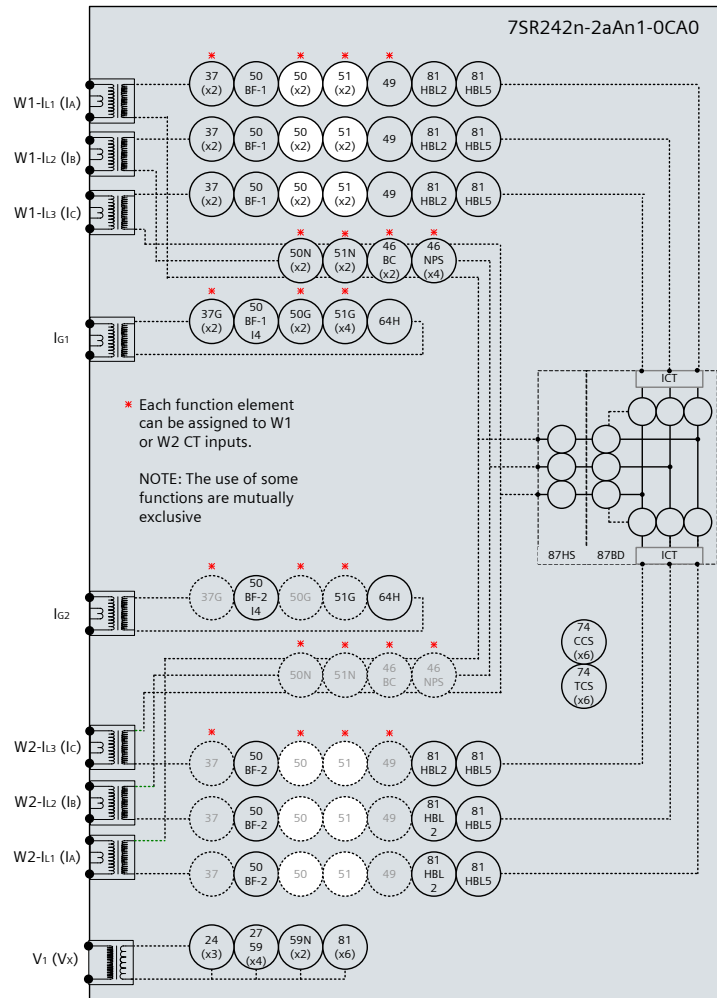

Figure 2-3 Phase Overcurrent

Voltage Inputs:	None
Current Inputs:	W1-I _{L1} (I _A), W1-I _{L2} (I _B), W1-I _{L3} (I _C), or W2-I _{L1} (I _A), W2-I _{L2} (I _B), W2-I _{L3} (I _C),
Disable:	46, 49, 50BF, 87BD, 87HS
Map Pickup LED:	51-n/50-n - Self Reset

Other protection functions may overlap with these functions during testing, it may be useful to disable some functions to avoid ambiguity.

These elements can be allocated to W1 or W2 current inputs by relay settings, ensure that current is injected on the correct input.

Particular care should be taken when testing overcurrent functions that the thermal rating of the current inputs is not exceeded.

2.1.4 Definite Time Overcurrent (50)

If DTL setting is small, gradually increase current until element operates.

If DTL is large apply 0.9x setting, check for no operation, apply 1.1x setting, check operation

Apply 2x setting current if possible and record operating time

Phase	Dir.	Is (Amps)	DTL (sec)	P.U. Current Amps	Operate Time 2 x Is	NOTES
I _{L1} (I _A)						
I _{L2} (I _B)						
I _{L3} (I _C)						

Check correct indication, trip output, alarm contacts, waveform record.

2.1.5 Inverse Time Overcurrent (51)

It will be advantageous to map the function being tested to temporarily drive the relevant Pickup output in the *Pickup Config* sub-menu in the *Output Config* menu as this will allow the Pick-up LED to operate for the function.

Gradually increase current until Pickup LED operates.

Apply 2x setting current and record operating time,

Apply 5x setting current and record operating time.

Compare to calculated values for operating times

P.U. D.O. & TIMING TESTS	Ph.	Dir	Char. (NI EI VI LTI, DTL)	Is (A)	TM	Operate Current		Operate Time		NOTES
						P.U. (Amps)	D.O. (Amps)	2 x Is (sec)	5 x Is (sec)	
	I _{L1} (I _A)									
	I _{L2} (I _B)									
	I _{L3} (I _C)									

Calculated Timing values in seconds for TM =1.0

Curve	2 x Is	5 x Is
IEC-NI	10.03	4.28
IEC-VI	13.50	3.38
IEC-EI	26.67	3.33
IEC-LTI	120.00	30.00
ANSI-MI	3.80	1.69
ANSI-VI	7.03	1.31
ANSI-EI	9.52	1.30

Note that the operate time may be subject to the **Minimum op time** setting for the element and/or may have a **Follower DTL** applied.

2.1.5.1 Element Blocking

The Phase Overcurrent elements can be blocked by Binary Input Inhibit and Inrush Detector operation. This functionality should be checked.

Element	BI Inhibits	Inrush Detector
51-1		
51-2		
50-1		
50-2		

2.1.5.2 ANSI Reset

If the element is configured as an ANSI characteristic, it may have an ANSI (decaying) reset delay applied. If ANSI reset is selected for an IEC characteristic element, the reset will be instantaneous.

ANSI reset times from operated condition to fully reset are as follows for zero applied current and Time multiplier (TM) = 1.0. The reset curve characteristic type and TM is defined by the operating characteristic.

Curve	Fully operated to reset with Zero current applied & TM=1 (secs)
ANSI-MI	4.85
ANSI-VI	21.6
ANSI-EI	29.1

Apply current in the following sequence, a) 2x setting for a time to ensure element operation, b) Zero current for the reset time above (xTM), c) 2x setting for a time to ensure element operation. Check that the second operation (c) is similar to the first (a) and in line with the expected operate time for the element at this current level.

Repeat the test with the reset time (b) reduced to 50% of the previous value. Ensure that the second operate time (c) is 50% of the first (a) operate time.

Operate time (expected)	Reset time (calculated)	Operate time (measured)	50% Reset Time (calculated)	50% operate time (calculated)	50% operate time (measured)
		First test (c)			Second Test (c)

Check correct indication, trip output, alarm contacts, waveform record.

2.2 Derived Earth fault (50N,51N)

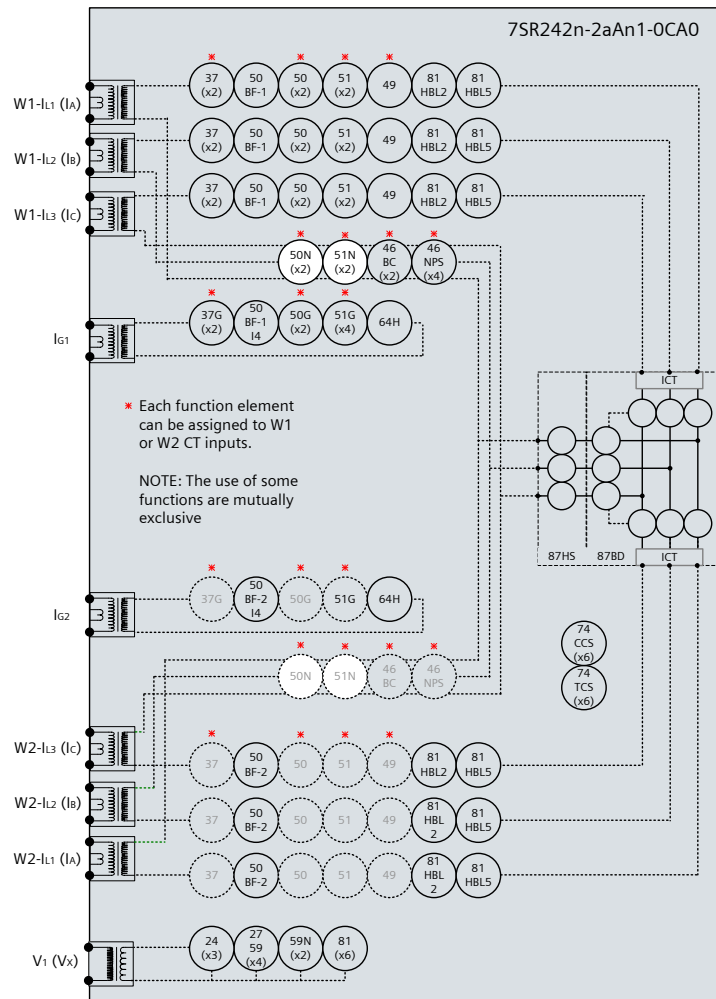

Figure 2-4 Measured Earth Fault

Voltage Inputs:	None
Current Inputs:	W1-I _{L1} (I _A), W1-I _{L2} (I _B), W1-I _{L3} (I _C), or W2-I _{L1} (I _A), W2-I _{L2} (I _B), W2-I _{L3} (I _C),
Disable:	50BF, 50, 51, 49, 37
Map Pickup LED:	51N-n/50N-n - Self Reset

Other protection functions may overlap with these functions during testing, it may be useful to disable some functions to avoid ambiguity. Measured EF & Restricted EF protections can be Enabled/Disabled individually or as groups in the 'Function Config' menu.

These elements can be allocated to W1 or W2 current inputs by relay settings, ensure that current is injected on the correct input.

Derived EF elements can be separated from Measured EF by secondary injection of current through the phase input circuit only.

2.2.1 Definite Time Overcurrent (50N)

If DTL setting is small, gradually increase current until element operates.

If DTL is large apply 0.9x setting, check for no operation, apply 1.1x setting, check operation

Apply 2x setting current if possible and record operating time

Input	Is (Amps)	DTL (sec)	P.U. Current Amps	Operate Time 2 x Is	NOTES

Check correct indication, trip output, alarm contacts, waveform record.

2.2.2 Inverse Time Overcurrent (51N)

It will be advantageous to map the function being tested to temporarily drive the relevant Pickup output in the *Pickup Config* sub-menu in the *Output Config* menu as this will allow the Pick-up led to operate for the function.

Gradually increase current until Pickup LED operates.

Apply 2x setting current and record operating time,

Apply 5x setting current and record operating time.

Compare to calculated values for operating times

P.U. D.O. & TIMING TESTS	Input	Char. (NI EI VI LTI, DTL)	Is (A)	T.M.	Operate Current	Operate Time	NOTES		
					P.U. (Amps)	D.O. (Amps)	2 x Is (sec)	5 x Is (sec)	

Calculated Timing values in seconds for TM =1.0

Curve	2 xIs	5 xIs
IEC-NI	10.03	4.28
IEC-VI	13.50	3.38
IEC-EI	26.67	3.33
IEC-LTI	120.00	30.00
ANSI-MI	3.80	1.69
ANSI-VI	7.03	1.31
ANSI-EI	9.52	1.30

Note that the operate time may be subject to the *Minimum op time* setting for the element and/or may have a *Follower DTL* applied.

2.2.2.1 Element Blocking

The Measured Earth Fault elements can be blocked by Binary Input Inhibit, VT Supervision and Inrush Detector operation. The Characteristic can be made non-directional by VT Supervision. This functionality should be checked.

Element	BI Inhibits	Inrush Detector
51N-1		
51N-2		
51N-3		
51N-4		
50N-1		
50N-2		
50N-3		
50N-4		

2.2.3 ANSI Reset

If the element is configured as an ANSI characteristic, it may have a reset delay applied. If ANSI reset is selected for an IEC characteristic element, the reset will be instantaneous.

ANSI reset times from operated condition to fully reset are as follows for zero applied current and $TM = 1.0$. The reset curve characteristic type and TM is defined by the operating characteristic.

Curve	Fully operated to reset with Zero current applied & $TM=1$ (secs)
ANSI-MI	4.85
ANSI-VI	21.6
ANSI-EI	29.1

Apply current in the following sequence, a) 2x setting for a time to ensure element operation, b) Zero current for the reset time above (xTM), c) 2x setting for a time to ensure element operation. Check that the second operation (c) is similar to the first (a) and in line with the expected operate time for the element at this current level.

Repeat the test with the reset time (b) reduced to 50% of the previous value. Ensure that the second operate time (c) is 50% of the first (a) operate time.

Operate time (expected)	Reset time (calculated)	Operate time (measured)	50% Reset Time (calculated)	50% operate time (calculated)	50% operate time (measured)
		First test (c)			Second Test (c)

Check correct indication, trip output, alarm contacts, waveform record.

2.3 Measured Earth fault (50G, 51G)

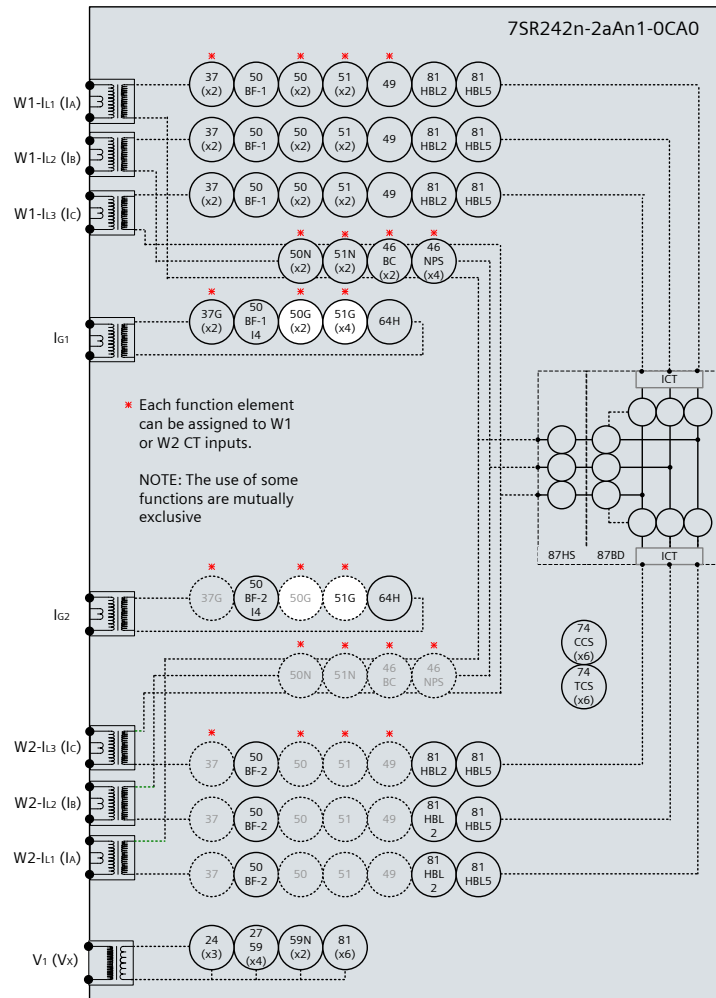

Figure 2-5 Measured Earth Fault

Voltage Inputs:	None
Current Inputs:	I _{G1} , I _{G2}
Disable:	50BF, 64H
Map Pickup LED:	51G-n/50G-n - Self Reset

Other protection functions may overlap with these functions during testing, it may be useful to disable some functions to avoid ambiguity. Derived EF, Measured EF & Restricted EF protections can be Enabled/Disabled individually or as groups in the 'Function Config' menu.

These elements can be allocated to I_{G1} or I_{G2} current inputs by relay settings, ensure that current is injected on the correct input.

Measured EF elements can be separated from Derived EF by secondary injection of current through the I_{G1} or I_{G2} input circuit only.

2.3.1 Definite Time Overcurrent (50G)

If DTL setting is small, gradually increase current until element operates.

If DTL is large apply 0.9x setting, check for no operation, apply 1.1x setting, check operation

Apply 2x setting current if possible and record operating time

Input	Is (Amps)	DTL (sec)	P.U. Current Amps	Operate Time 2 x Is	NOTES
I _{G1}					

Check correct indication, trip output, alarm contacts, waveform record.

2.3.2 Inverse Time Overcurrent (51G)

It will be advantageous to map the function being tested to temporarily drive the relevant Pickup output in the *Pickup Config* sub-menu in the *Output Config* menu as this will allow the Pick-up LED to operate for the function.

Gradually increase current until Pickup LED operates.

Apply 2x setting current and record operating time,

Apply 5x setting current and record operating time.

Compare to calculated values for operating times

P.U. D.O. & TIMING TESTS	Input	Char. (NI EI VI LTI, DTL)	Is (A)	T.M.	Operate Current		Operate Time		NOTES
					P.U. (Amps)	D.O. (Amps)	2 x Is (sec)	5 x Is (sec)	
	I _{G1}								

Calculated Timing values in seconds for TM =1.0

Curve	2 x Is	5 x Is
IEC-NI	10.03	4.28
IEC-VI	13.50	3.38
IEC-EI	26.67	3.33
IEC-LTI	120.00	30.00
ANSI-MI	3.80	1.69
ANSI-VI	7.03	1.31
ANSI-EI	9.52	1.30

Note that the operate time may be subject to the *Minimum op time* setting for the element and/or may have a *Follower DTL* applied.

2.3.2.1 Element Blocking

The Measured Earth Fault elements can be blocked by Binary Input Inhibit, VT Supervision and Inrush Detector operation. The Characteristic can be made non-directional by VT Supervision. This functionality should be checked.

Element	BI Inhibits	Inrush Detector
51G-1		
51G-2		
51G-3		
51G-4		
50G-1		
50G-2		
50G-3		
50G-4		

2.3.3 ANSI Reset

If the element is configured as an ANSI characteristic, it may have a reset delay applied. If ANSI reset is selected for an IEC characteristic element, the reset will be instantaneous.

ANSI reset times from operated condition to fully reset are as follows for zero applied current and $TM = 1.0$. The reset curve characteristic type and TM is defined by the operating characteristic.

Curve	Fully operated to reset with Zero current applied & $TM=1$ (secs)
ANSI-MI	4.85
ANSI-VI	21.6
ANSI-EI	29.1

Apply current in the following sequence, a) 2x setting for a time to ensure element operation, b) Zero current for the reset time above (xTM), c) 2x setting for a time to ensure element operation. Check that the second operation (c) is similar to the first (a) and in line with the expected operate time for the element at this current level.

Repeat the test with the reset time (b) reduced to 50% of the previous value. Ensure that the second operate time (c) is 50% of the first (a) operate time.

Operate time (expected)	Reset time (calculated)	Operate time (measured)	50% Reset Time (calculated)	50% operate time (calculated)	50% operate time (measured)
		First test (c)			Second Test (c)

Check correct indication, trip output, alarm contacts, waveform record.

2.4 Restricted Earth fault (64H)

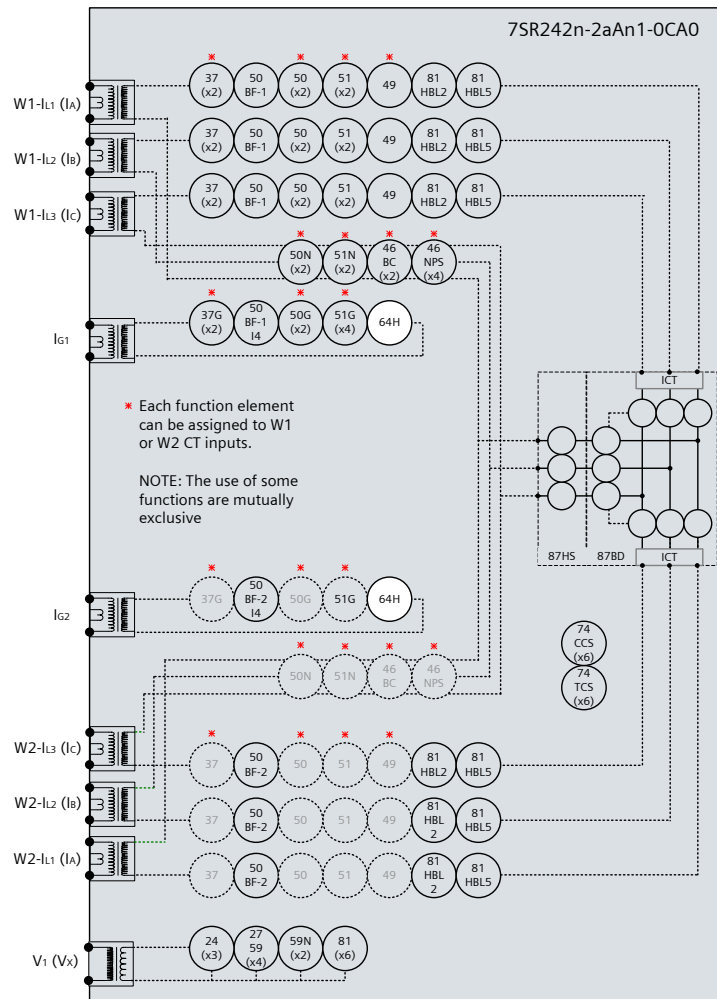

Figure 2-6 Restricted Earth Fault

Voltage Inputs:	n/a
Current Inputs:	I _{G1} , I _{G2}
Disable:	50G, 51G, 50BF
Map Pickup LED:	64H-n - Self Reset

The external stabilising resistor value should be measured and compared to that specified in the settings data. Both values should be recorded.

Element	Settings Data: R _{STAB} Value	R _{STAB} Measured
64H-1		
64H-2		

The relatively high value of stabilising resistance R_{STAB} will often interfere with secondary current injection when using a digital test set. It is normal practice in these cases to short circuit the resistor to allow testing, the shorting link should be removed after testing.

These elements can be enabled for the I_{G1} or I_{G2} current inputs by relay settings, ensure that current is injected on the correct input.

Since the DTL setting is generally small the pick-up setting can be tested by gradually increasing current until element operates. The relay should be disconnected from the current transformers for this test.

Apply 2x setting current if possible and record operating time

	Is (Amps)	DTL (sec)	P.U. Current Amps	Operate Time 2 x Is	NOTES
64H-1					
64H-2					

It is also desirable to check the operating voltage achieved with the setting resistor and all parallel CTs connected but de-energised. A higher capacity test set will be required for this test. Adequate current must be supplied to provide the magnetising current of all connected CTs. Precautions should be taken to ensure that no personnel are at risk of contact with any of the energised secondary wiring during the test.

	Settings Data: Voltage Setting (V_s)	V_s Measured	Settings Data: Operate Current (I_{OP})	I_{OP} Measured
64H-1				
64H-2				

To complete testing of the REF requires primary injection through the phase and residual (REF) CT in series to simulate an out of zone fault and ensure stability of the relay. The test can then be repeated with the REF CT secondary connections reversed to prove operation.

2.4.1.1 Element Blocking

The Restricted Earth Fault element can be blocked by Binary Input Inhibit. Where applied this functionality should be checked.

Element	BI Inhibits	Checked
64H-1		
64H-2		

Check correct indication, trip output, alarm contacts, waveform record.

Check that any shorting links are removed after testing.

2.5 Open Circuit (46BC)

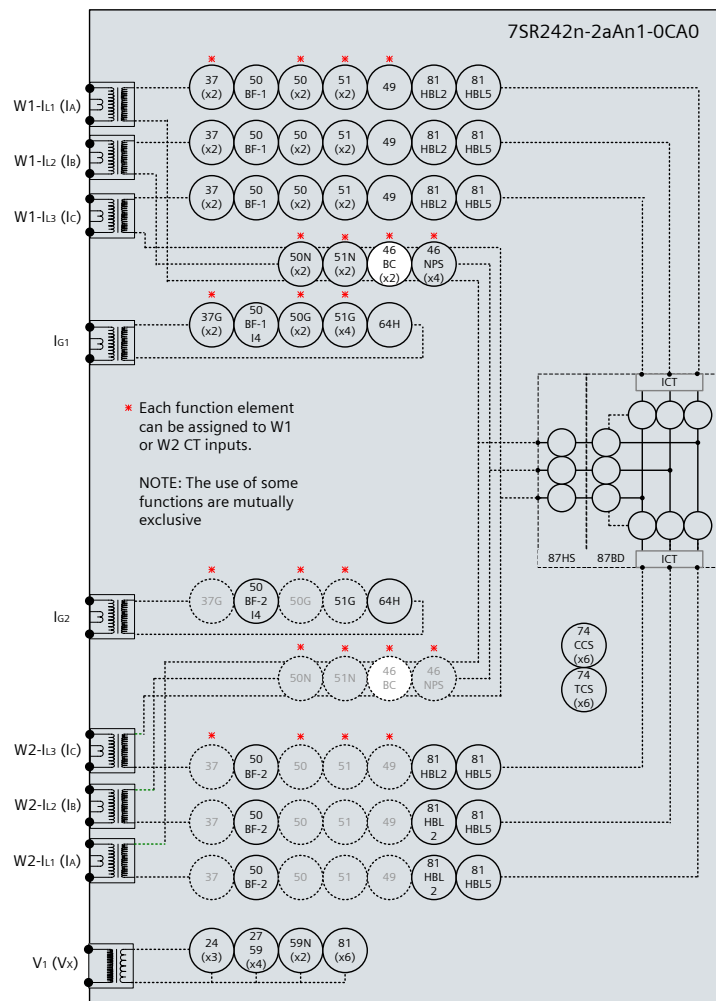

Figure 2-7 Open Circuit

Voltage Inputs:	n/a
Current Inputs:	W1-I _{L1} (I _A), W1-I _{L2} (I _B), W1-I _{L3} (I _C), or W2-I _{L1} (I _A), W2-I _{L2} (I _B), W2-I _{L3} (I _C),
Disable:	51N, 46IT, 46DT
Map Pickup LED:	46BC - Self Reset

This function uses the ratio of NPS current to PPS current to detect an open circuit. These quantities can be produced directly from many advanced test sets but with limited equipment the following approach can be applied.

Apply 3P balanced current with normal phase rotation direction. This current will consist of PPS alone, no NPS or ZPS.

Increase 1 phase current magnitude in isolation to produce NPS. The single phase unbalance current will contain equal quantities of ZPS, NPS and PPS. The NPS component will be 1/3 of the unbalance current and the total PPS component will be value of the original balanced 3P current plus 1/3 of the additional unbalance current. i.e. as the single phase unbalance current increases, the ratio of NPS to PPS will also increase. The levels of each sequence component current can be monitored in the **Current Meters** in **Instruments Mode**.

Inject 1A of balanced current. Gradually increase imbalance current, operating level should be as follows:

46BC Setting	1P unbalance current (% of 3P current)
20%	75%
25%	100%
30%	129%
35%	161%
40%	200%

46BC Setting	3P balanced current (A)	1P unbalance current (A)	Measured Unbalance current
46BC-1			
46BC-2			

Apply 1A 1P unbalance current without 3P balanced current. Measure 46BC operating time.

46BC Delay setting	Measured
46BC-1	
46BC-2	

2.5.1.1 Element Blocking

Elements can be blocked by operation of a Binary Input Inhibit or by operation of the 46BC-n U/I Guard element.

This functionality should be checked.

Element	BI Inhibits	U/I Guard	NOTES
46BC-1			
46BC-2			

2.6 Negative Phase Sequence Overcurrent (46NPS)

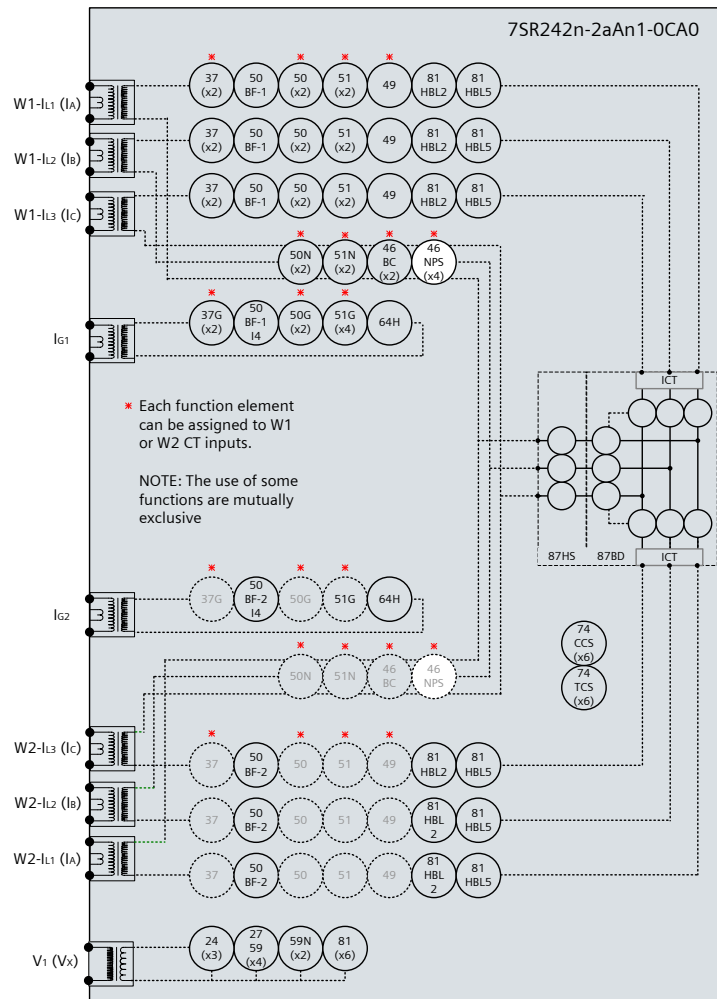

Figure 2-8 Negative Phase Sequence Overcurrent

Voltage Inputs:	n/a
Current Inputs:	W1-I _{L1} (I _A), W1-I _{L2} (I _B), W1-I _{L3} (I _C), or W2-I _{L1} (I _A), W2-I _{L2} (I _B), W2-I _{L3} (I _C),
Disable:	50, 51, 50BF, 87BD
Map Pickup LED:	46IT/46DT - Self Reset

Where two NPS elements are being used with different settings, it is convenient to test the elements with the highest settings first. The elements with lower settings can then be tested without disabling the lower settings. The Thermal withstand limitations of the current inputs, stated in the Performance Specification should always be observed throughout testing.

These elements can be allocated to W1 or W2 current inputs by relay settings, ensure that current is injected on the correct input.

NPS Overcurrent can be tested using a normal 3P balanced source. Two phase current connections should be reversed so that the applied balanced 3P current is Negative Phase Sequence.

2.6.1 Definite Time NPS Overcurrent (46DT)

If DTL setting is small, gradually increase current until element operates.

If DTL is large apply 0.9x setting, check for no operation, apply 1.1x setting, check operation

Apply 2x setting current if possible and record operating time

Phase	Is (Amps)	DTL (sec)	P.U. Current Amps	Operate Time 2 x Is	NOTES
NPS					

Check correct indication, trip output, alarm contacts, waveform record.

2.6.2 Inverse Time NPS Overcurrent (46IT)

It will be advantageous to map the function being tested to temporarily drive the relevant Pickup output in the *Pickup Config* sub-menu in the *Output Config* menu as this will allow the Pick-up led to operate for the function.

Gradually increase current until Pickup LED operates.

Apply 2x setting current and record operating time,

Apply 5x setting current and record operating time.

Compare to calculated values for operating times

P.U. D.O. & TIMING TESTS	Ph.	Char. (NI EI VI LTI, DTL)	Is (A)	TM	Operate Current		Operate Time		NOTES
					P.U. (Amps)	D.O. (Amps)	2 x Is (sec)	5 x Is (sec)	
	NPS								

Calculated Timing values in seconds for TM =1.0

Curve	2 x Is	5 x Is
IEC-NI	10.03	4.28
IEC-VI	13.50	3.38
IEC-EI	26.67	3.33
IEC-LTI	120.00	30.00
ANSI-MI	3.80	1.69
ANSI-VI	7.03	1.31
ANSI-EI	9.52	1.30

Note that the operate time may be subject to the *Minimum op time* setting for the element and/or may have a *Follower DTL* applied.

2.6.2.1 ANSI Reset

If the element is configured as an ANSI characteristic, it may have a reset delay applied. If ANSI reset is selected for an IEC characteristic element, the reset will be instantaneous.

ANSI reset times from operated condition to fully reset are as follows for zero applied current and $TM = 1.0$. The reset curve characteristic type and TM is defined by the operating characteristic.

Curve	Fully operated to reset with Zero current applied & $TM=1$ (secs)
ANSI-MI	4.85
ANSI-VI	21.6
ANSI-EI	29.1

Apply current in the following sequence, a) 2x setting for a time to ensure element operation, b) Zero current for the reset time above (xTM), c) 2x setting for a time to ensure element operation. Check that the second operation (c) is similar to the first (a) and in line with the expected operate time for the element at this current level.

Repeat the test with the reset time (b) reduced to 50% of the previous value. Ensure that the second operate time (c) is 50% of the first (a) operate time.

Operate time (expected)	Reset time (calculated)	Operate time (measured)	50% Reset Time (calculated)	50% operate time (calculated)	50% operate time (measured)
		First test (c)			Second Test (c)

2.6.2.2 Element Blocking

The NPS Overcurrent elements can be blocked by Binary Input Inhibit. This functionality should be checked.

Element	BI Inhibits
46IT	
46DT	

Check correct indication, trip output, alarm contacts, waveform record.

When testing is complete reinstate any of the disabled functions.

2.7 Undercurrent (37, 37G)

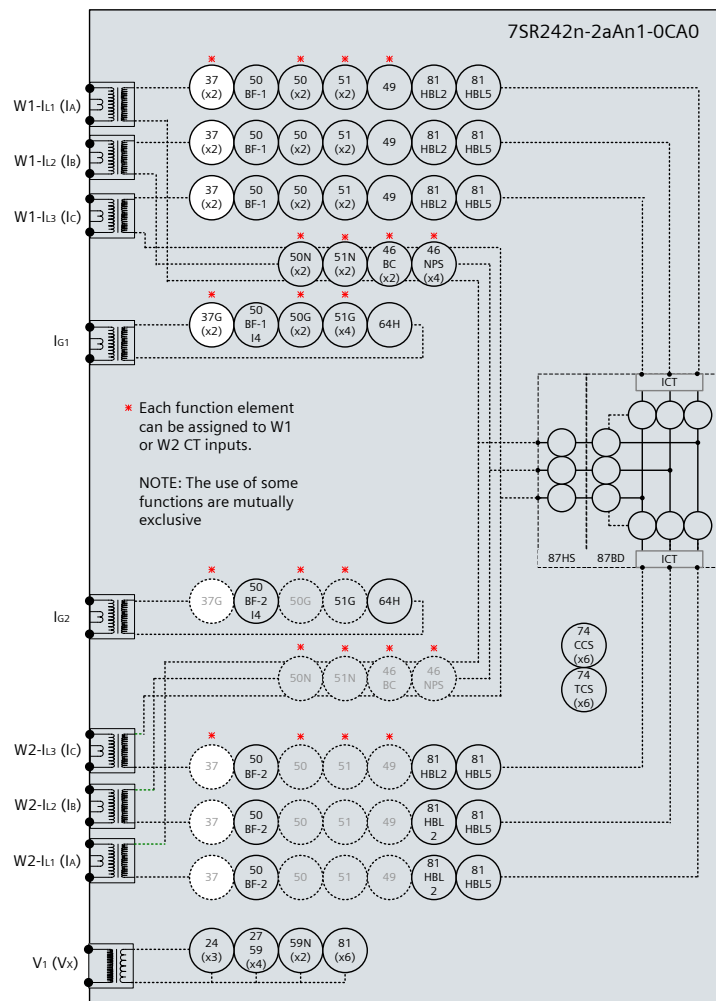

Figure 2-9 Undercurrent

Voltage Inputs:	n/a
Current Inputs:	W1-I _{L1} (I _A), W1-I _{L2} (I _B), W1-I _{L3} (I _C), I _{G1} or W2-I _{L1} (I _A), W2-I _{L2} (I _B), W2-I _{L3} (I _C), I _{G2}
Disable:	50N, 51N, 51G, 46, 87BD
Map Pickup LED:	37-n, 37G-n - Self Reset

2.7.1 37-n Elements

If two Undercurrent 37 elements are used with different settings, it is convenient to test the element with the lowest setting first. The higher setting element can then be tested without interference from the other element.

These elements can be allocated to W1 or W2 current inputs by relay settings, ensure that current is injected on the correct input.

Apply 3P balanced current at a level above the 37-n setting until the element resets.

If DTL setting is small, gradually reduce any each phase current in turn until element operates.

If DTL is large apply 1.1x setting, check for no operation, apply 0.9x setting, check operation

Testing of these elements phase by phase may cause inadvertent operation of the 46 NPS Overcurrent elements.

Apply 0.5x setting current and record operating time

Phase	Is (Amps)	DTL (sec)	P.U. Current Amps	Operate Time 0.5 x Is	NOTES
Wn-I _{L1} (I _A)					
Wn-I _{L2} (I _B)					
Wn-I _{L3} (I _C)					
Wn-I _{L1} (I _A)					
Wn-I _{L2} (I _B)					
Wn-I _{L3} (I _C)					

Elements can be blocked by operation of a Binary Input Inhibit or by operation of the 37-n U/I Guard element. This functionality should be checked.

Element	BI Inhibits	U/I Guard	NOTES
37-1			
37-2			

Check correct indication, trip output, alarm contacts, waveform record.

2.7.2 37G-n Elements

Apply current to the I_{Gn} input at a level above the 37G-n setting until the element resets.

If DTL setting is small, gradually reduce current until element operates.

If DTL is large apply 1.1x setting, check for no operation, apply 0.9x setting, check operation

Apply 0.5x setting current and record operating time

Phase	Is (Amps)	DTL (sec)	P.U. Current Amps	Operate Time 0.5 x Is	NOTES
I _G					
I _G					

Elements can be blocked by operation of a Binary Input Inhibit.

This functionality should be checked.

Element	BI Inhibits	NOTES
37G-1		
37G-2		

Check correct indication, trip output, alarm contacts, waveform record.

2.8 Thermal Overload (49)

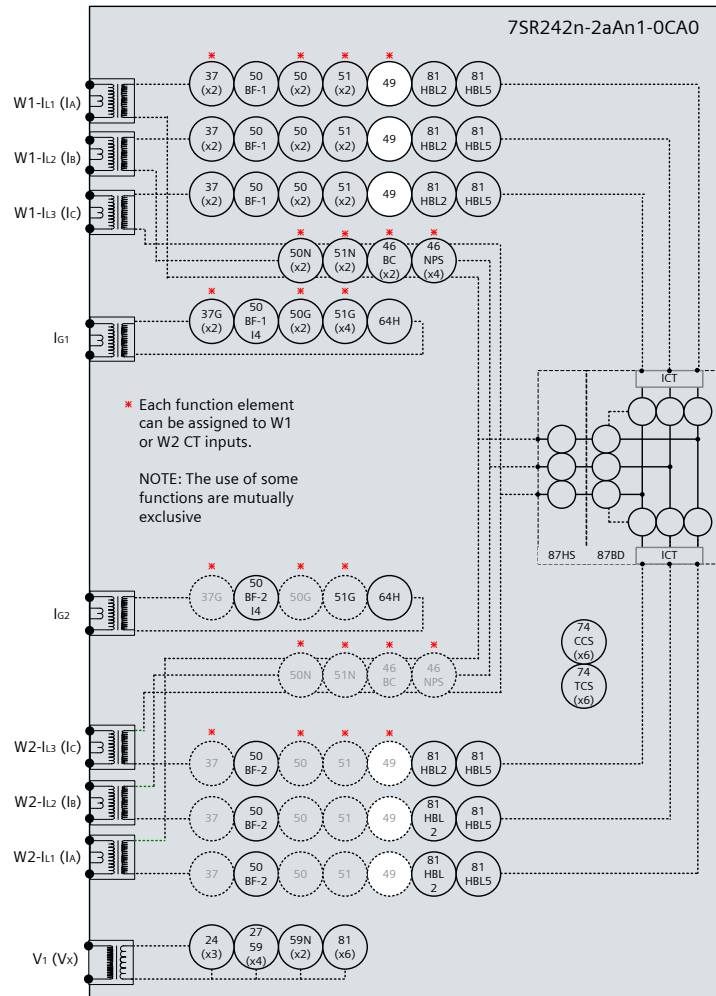

Figure 2-10 Thermal Overload

Voltage Inputs:	n/a
Current Inputs:	W1-I _{L1} (I _A), W1-I _{L2} (I _B), W1-I _{L3} (I _C), or W2-I _{L1} (I _A), W2-I _{L2} (I _B), W2-I _{L3} (I _C),
Disable:	51, 50, 37, 46NPS, 50CBF, 87BD
Map Pickup LED:	49 Alarm

The current can be applied from a 3P balanced supply or phase by phase from a 1P supply. Alternatively the 3 phase current inputs can be connected in series and injected simultaneously from a single 1P source.

This elements can be allocated to W1 or W2 current inputs by relay settings, ensure that current is injected on the correct input.

The Thermal Overload Setting and Time Constant Setting can be considered together to calculate the operating time for a particular applied current.

The following table lists operate times for a range of Time Constant Settings for an applied current of 2x the Thermal Overload setting. Ensure that the thermal rating of the relay is not exceeded during this test.

Time Constant (mins)	Operate Time (sec)
1	17.3
2	34.5
3	51.8
4	69
5	86.3
10	173
15	259
20	345
25	432
30	51.8
50	863
100	1726

The Thermal State must be in the fully reset condition in order to measure the operate time correctly. This can be achieved by setting change in the Thermal protection settings menu or by pressing the Test/Reset button when the Thermal Meter is shown in the Instruments Mode.

Reset the thermal State then apply 2x the Overload Setting current.

Calculated Operate Time (s)	Measured Operate Time (s)

If the Thermal Overload Capacity Alarm is used, this can be tested by monitoring the Thermal Capacity in the instruments menu. If the Thermal time constant is longer than a few minutes, this can be assessed during the timing test above. If the Time Constant is less than a few minutes, a lower multiple of current will be required such that the rate of capacity increase is slowed to allow monitoring of the instrument to be accurate.

Capacity Alarm Setting	Measured

2.8.1.1 Element Blocking

The Thermal element can be blocked by Binary Input Inhibit. This functionality should be checked.

Element	BI Inhibits
49	

2.9 Under/Over Voltage (27/59)

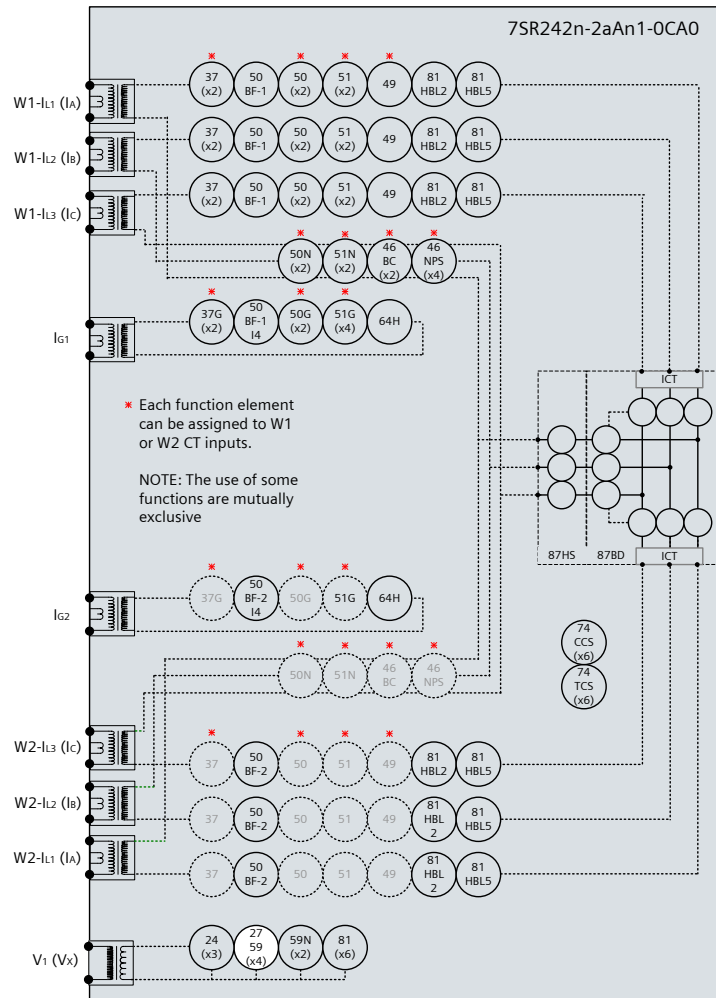

Figure 2-11 Phase Under/Over Voltage

Voltage Inputs:	V ₁ (V _x)
Current Inputs:	n/a apply zero current to stabilize other functions
Disable:	59N
Map Pickup LED:	27/59-n - Self Reset

Where more than one Undervoltage (27) elements are being used with different settings, it is convenient to test the elements with the lowest settings first. The elements with higher settings can then be tested without disabling the lower settings.

Note that if the voltage is reduced below the 27UVG setting, the function may be blocked. Current inputs are not required to stabilize the relay during voltage element testing.

If the DTL is short, starting from nominal voltage, slowly decrease the applied test voltage until the Pickup LED (temporarily mapped) is lit. Record the operate voltage. The LED should light at setting Volts +/-5%. Slowly increase the input voltage until the LED extinguishes. Record the reset voltage to check the 'Hysteresis' setting. If the DTL is long, the operate level should be checked by applying a voltage of 90% of setting voltage. Check Hysteresis by resetting element to the operate level setting plus the hysteresis setting.

Connect the relevant output contact(s) to stop the test set. Step the applied voltage to a level below the setting. The test set should be stopped at the operate time setting +/-5%

When testing is complete reinstate any of the disabled functions.

Where more than one Overvoltage (59) elements are being used with different settings, it is convenient to test the elements with the highest settings first. The elements with lower settings can then be tested without disabling the higher settings.

If the 'O/P Phases' is set to 'All', the voltage on all phases must be increased simultaneously. Otherwise the 3 phases should be tested individually. If the DTL setting is short, starting from nominal voltage, slowly increase the applied 3P or VL1 test voltage until the Pickup LED (temporarily mapped) is lit. The LED should light at setting Volts +/-5% Decrease the input voltage to nominal Volts and the LED will extinguish. Record the reset voltage to check the 'Hysteresis' setting. If the DTL setting is long, the operate level can be checked by applying 100% of setting to cause operation followed by setting minus the Hysteresis setting to cause reset.

Connect the relevant output contact(s) to stop the test set. Step the applied voltage to a level above the setting. The test set should be stopped at the operate time setting +/-5%

Test inputs VL2 and VL3 by repeating the above if necessary.

Phase	27/59 setting (Volts)	U/O	DTL (sec)	Hyst.	D.O. (calculated)	P.U. Volts	D.O Volts	Op. Time 2x Vs (OV) 0.5x Vs (UV)	UV Guard	NOTES
V ₁ (V _X)										

2.9.1.1 Element Blocking

The NPS Overcurrent elements can be blocked by Binary Input Inhibit and VT Supervision. This functionality should be checked.

Element	BI Inhibits
27/59-1	
27/59-2	
27/59-3	
27/59-4	

When testing is complete reinstate any of the disabled functions.

2.9.2 Undervoltage Guard (27/59UVG)

If any 27 Undervoltage element is set to be inhibited by the 27 Undervoltage Guard element, this function should be tested.

Connect the test voltage inputs to suit the installation wiring diagram utilising any test socket facilities available. It may be useful to temporarily map an LED as 'General Pickup' to assist during testing. 27UVG operation will reset the General Pickup if no other element is operated. This LED should not be set as 'Hand Reset' in the Output matrix.

Starting from nominal voltage, apply a step decrease to the applied voltage to a level below the 27 Undervoltage setting but above the 27UVG setting such that an Undervoltage element operation occurs. Slowly reduce the applied voltage until the 27 Undervoltage element resets, this can be detected by the General Pickup LED reset if no other element is operated (this includes any Undervoltage element which is not UV Guarded).

Phase	Vs (Volts)	V element Used for test	Blocked Volts	NOTES
UVG				

2.10 Neutral Over Voltage (59N)

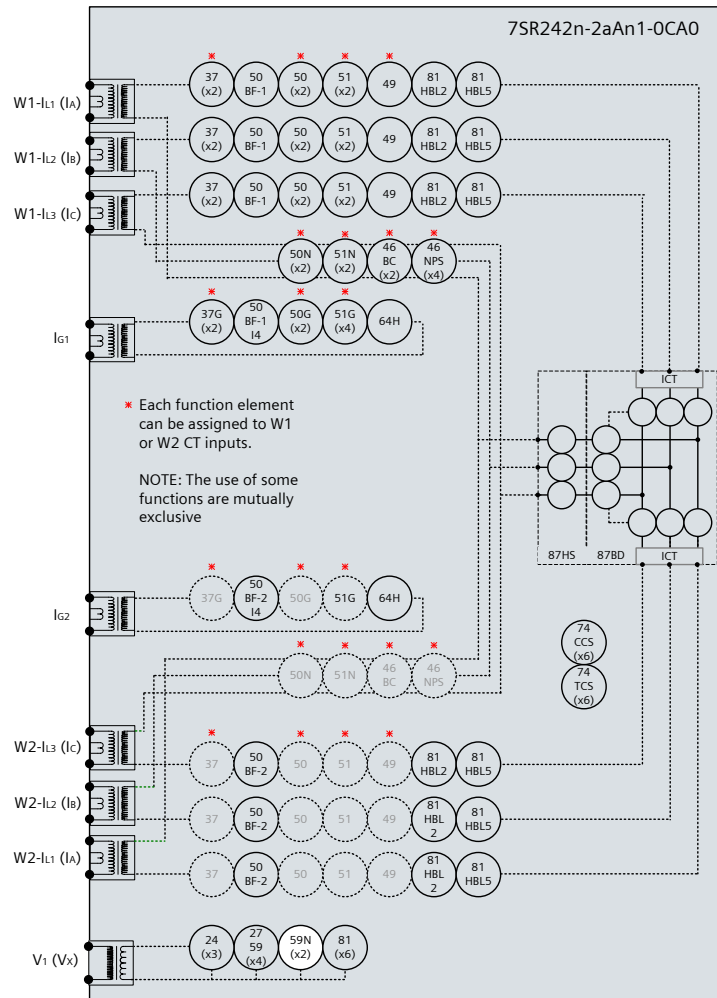

Figure 2-12 Neutral Overvoltage

Voltage Inputs:	V ₁ (V _x)
Current Inputs:	n/a apply zero current to stabilize other functions
Disable:	27/59
Map Pickup LED:	59N-n - Self Reset

2.10.1 Definite Time (59NDT)

If DTL setting is small, gradually increase single phase voltage until element operates.

If DTL is large apply 0.9x setting, check for no operation, apply 1.1x setting, check operation

Apply 2x setting voltage if possible and record operating time

Phase	Vs (Volts)	DTL (sec)	P.U. Current Volts	Operate Time 2 x Vs	NOTES
V ₁ (V _x)					

Check correct indication, trip output, alarm contacts, waveform record.

2.10.2 Inverse Time (59NIT)

It will be advantageous to map the function being tested to temporarily drive the relevant Pickup output in the *Pickup Config* sub-menu in the *Output Config* menu as this will allow the Pick-up LED to operate for the function.

Gradually increase voltage until Pickup LED operates.

Apply 2x setting voltage and record operating time,

Apply a higher multiple of setting voltage and record operating time.

Compare to calculated values for operating times from:

$$t_{op}(\text{seconds}) = M \left[\frac{1}{\left[\frac{V_n}{V_s} \right] - 1} \right]$$

Where M = Time multiplier and V_n/V_s = multiple of setting.

Ph.	Vs (V)	TM	Operate Voltage		Operate Time		NOTES
			P.U. (Volts)	D.O. (Volts)	2 x Vs (sec)	x Vs (sec)	
V ₁ (V _x)							

2.10.2.1 Element Blocking

The Neutral Overvoltage elements can be blocked by Binary Input Inhibit. This functionality should be checked.

Element	BI Inhibits
59NIT	
59NDT	

Check correct indication, trip output, alarm contacts, waveform record.

When testing is complete reinstate any of the disabled functions.

2.11 Under/Over Frequency (81)

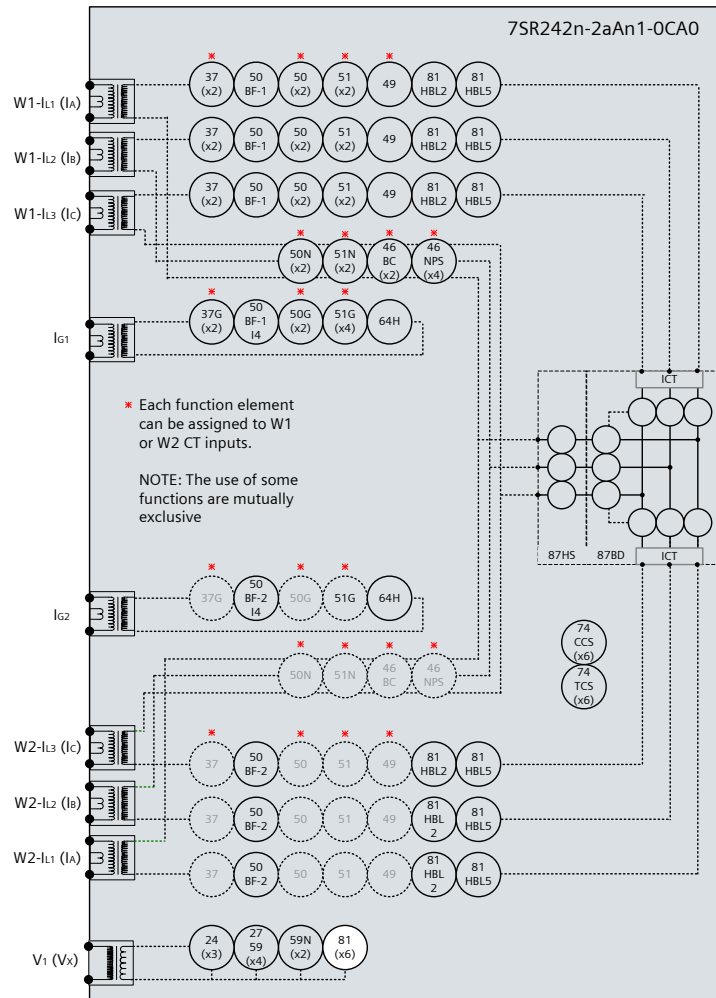

Figure 2-13 Under/Over Frequency

Voltage Inputs:	V ₁ (V _x)
Current Inputs:	n/a apply zero current to stabilize other functions
Disable:	
Map Pickup LED:	81-n - Self Reset

For Over-frequency, the elements with the highest setting should be tested first and for Under-frequency the elements with the lowest settings should be tested first. The elements with other settings can then be tested without need to disable the elements already tested. Note that the relay is designed to track the gradual changes in power system frequency and that sudden step changes in frequency during testing do not reflect normal system operation. Normal 'instantaneous' operation of the frequency element is 140-175ms in line with the Performance Specification. Application of sudden step changes to frequency can add additional delay which can produce misleading test results.

Gradually increase/decrease applied voltage frequency until 81-n operation occurs. Elements set for more extreme frequency fluctuation should be tested first with lesser elements disabled.

If the 81-n Delay setting is long it will be advantageous to map the function to temporarily drive the relevant Pickup output in the *Pickup Config* sub-menu in the *Output Config* menu as this will allow the Pick-up LED to operate for the function. If the delay setting is short the operation of the element can be easily checked directly.

The frequency should then be gradually decreased/increased until the element resets. The reset frequency can be used to check the Hysteresis setting.

If the element is set as **81-n U/V Guarded**, The applied voltage must be above the **81 UV Guard Setting** in the **U/O Frequency** menu.

Apply setting frequency +0.5Hz for Over-frequency or -0.5Hz for Under-frequency and record operating time.

Starting with the element in the operated condition, gradually increase or decrease the applied voltage until the element resets. Measure the reset voltage level to check the **81 Hysteresis** setting.

F (Hertz)	U/O	DTL (sec)	Hyst.	D.O. (calc.)	P.U. Freq Hertz	D.O. Freq. Hertz	Operate Time +/- 0.5Hz	UV Guard	NOTES

If the element is set as **81-nU/V Guarded**, this setting can be tested by applying the test voltage at a level below the **81 U/V Guard Setting** at a frequency in the operate range. Increase the voltage until the relay operates.

UVG	UVG Setting (Volts)	Freq element Used for test	Blocked Volts (D.O.)	Unblocked Volts (P.U.)	NOTES
U/O Freq					

2.11.1.1 Element Blocking

The U/O Frequency elements can be blocked by Binary Input Inhibit. This functionality should be checked.

Element	BI Inhibits
81-1	
81-2	
81-3	
81-4	
81-5	
81-6	

Check correct indication, trip output, alarm contacts, waveform record.

When testing is complete reinstate any of the disabled functions.

2.12 Overfluxing (24)

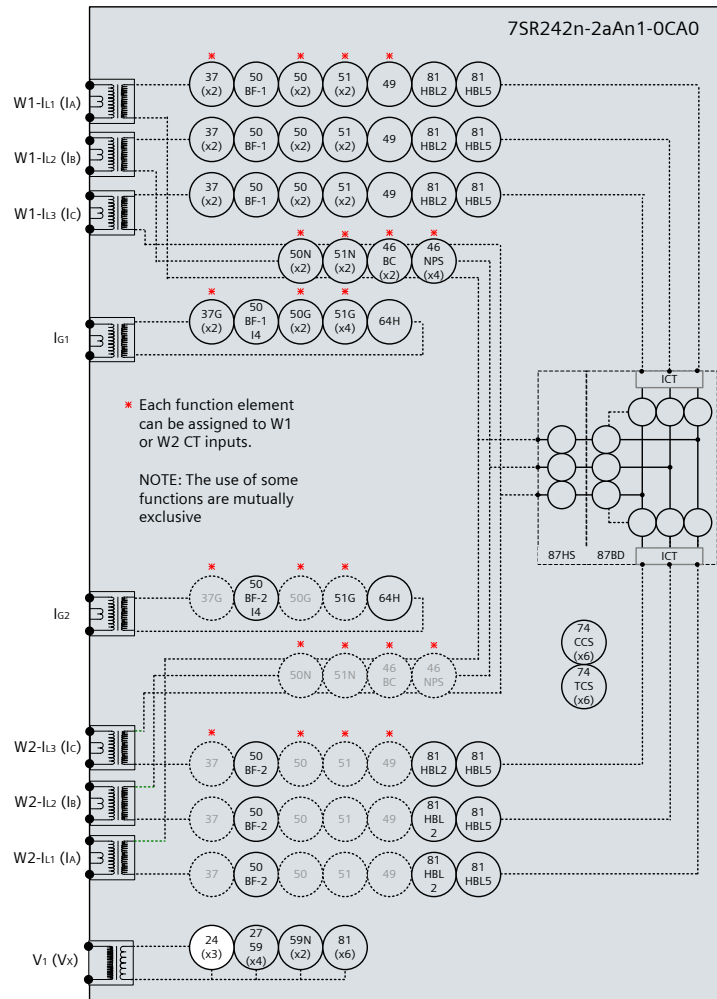

Figure 2-14 Under/Over Frequency

The settings are set in terms of V/f based on multiple of nominal voltage and frequency. Application of a voltage of nominal voltage and frequency represents 1.0.

Testing is simplified by applying nominal frequency and increasing voltage only, such that the operating level is simply the setting multiplied by *Nominal Voltage*.

2.12.1 definite time (24DT)

If DTL setting is small, gradually increase voltage until element operates.

If DTL is large apply 0.95x setting, check for no operation, apply 1.05x setting, check operation

Apply 0.9x voltage, increase to 1.1x setting and record operating time

Setting (xVn)	Setting (volts)	Hysteresis (%)	Calculated D.O. (volts)	DTL Setting (sec)	P.U. Volts	D.O. Volts	Operate Time	NOTES

Check correct indication, trip output, alarm contacts, waveform record.

2.12.2 inverse time (24IT)

The inverse V/f element should be tested at each of the points specified by settings that constitute the overall inverse characteristics.

Setting (xVn)	Setting (volts)	Hysteresis (%)	Calculated D.O. (volts)	DTL Setting (sec)	P.U. Volts	D.O. Volts	Operate Time	NOTES
X0				Y0				

Setting (xVn)	Setting (volts)	DTL Setting (sec)	Operate Time	NOTES
X1		Y1		
X2		Y2		
X3		Y3		
X4		Y4		
X5		Y5		
X6		Y6		

Section 3: Supervision Functions

3.1 CB Fail (50BF)

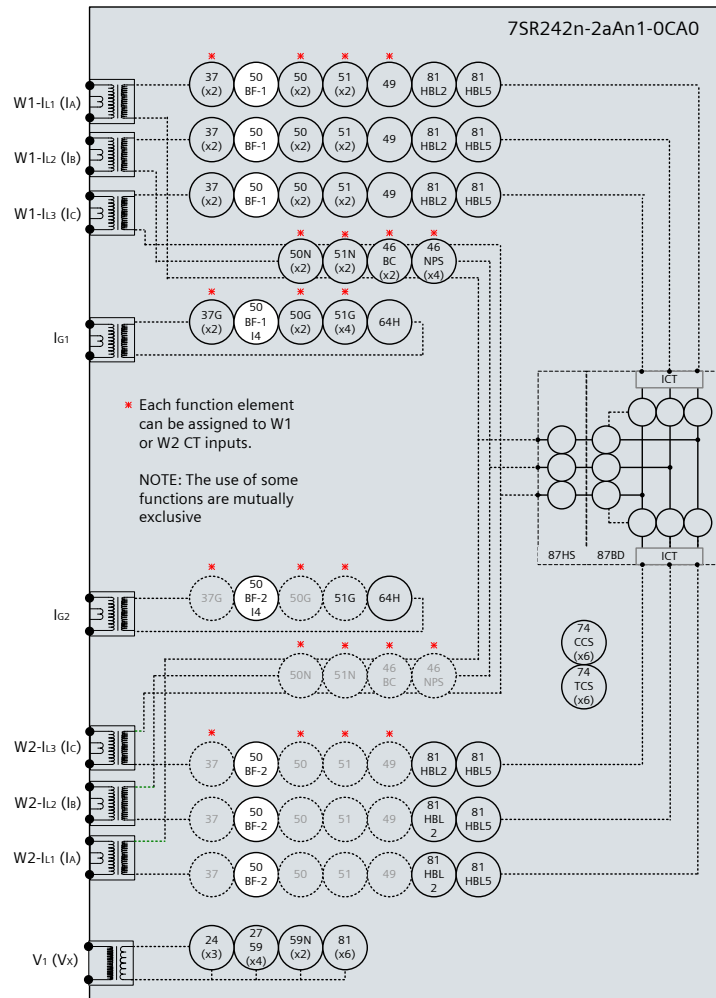

Figure 3-1 CB Fail

Voltage Inputs:	n/a
Current Inputs:	W1-I _{L1} (I _A), W1-I _{L2} (I _B), W1-I _{L3} (I _C), I _{G1} or W2-I _{L1} (I _A), W2-I _{L2} (I _B), W2-I _{L3} (I _C), I _{G2}
Disable:	
Map Pickup LED:	50BF-n-n - Self Reset

The circuit breaker fail protection time delays are initiated either from:

A binary output mapped as **Trip Contact** in the OUTPUT CONFIG>BINARY OUTPUT CONFIG menu,
or

A binary input mapped as **50BF Ext Trip** in the INPUT CONFIG>INPUT MATRIX menu.

Or

A binary input mapped as **50BF Mech Trip** in the INPUT CONFIG>INPUT MATRIX menu.

These elements are operated from W1 and W2 current inputs, ensure that current is injected on the correct input for the element being tested.

Apply a trip condition by injection of current to cause operation of a suitable protection element. Allow current to continue after the trip at a level of 110% of the *50BF Setting* current level on any phase. Measure the time for operation of *50BF-1 Delay* and *50BF-2 Delay*. Repeat the sequence with the 50BF CB Faulty input energised and ensure the 50BF-1 and 50BF-2 outputs operate without delay, by-passing the timer delay settings.

Repeat the sequence with current at 90% of the *50BF Setting* current level after the element trip and check for no CB Fail operation.

Repeat the sequence by injecting the current to I4 and using the *50BF-I4 Setting*.

Setting (xIn)	Test Current	50BF-1 Delay.....	50BF-2 Delay.....
50BF-1	(110%).....		
	(90%).....	No Operation <input type="checkbox"/>	No Operation <input type="checkbox"/>
	50BF CB Faulty	Operation No Delay <input type="checkbox"/>	Operation No Delay <input type="checkbox"/>
50BF-1-I4	(110%).....		
	(90%).....	No Operation <input type="checkbox"/>	No Operation <input type="checkbox"/>
	50BF CB Faulty	Operation No Delay <input type="checkbox"/>	Operation No Delay <input type="checkbox"/>
50BF-2	(110%).....		
	(90%).....	No Operation <input type="checkbox"/>	No Operation <input type="checkbox"/>
	50BF CB Faulty	Operation No Delay <input type="checkbox"/>	Operation No Delay <input type="checkbox"/>
50BF-2-I4	(110%).....		
	(90%).....	No Operation <input type="checkbox"/>	No Operation <input type="checkbox"/>
	50BF CB Faulty	Operation No Delay <input type="checkbox"/>	Operation No Delay <input type="checkbox"/>

If the circuit breaker can also receive a trip signal from a protection function where there is no increase in current, this trip input should be mapped to **50BF Mech Trip** in the INPUT CONFIG>INPUT MATRIX menu.

Initiate this binary input and simulate the circuit breaker remaining closed by ensuring the CB Closed binary Input is energised and ensure operation of the 50BF-1 and 50BF-2 outputs after their programmed delays.

Mech Trip		50BF-1 Delay.....	50BF-2 Delay.....
50BF-1	CB Closed		
	CB Open	No Operation <input type="checkbox"/>	No Operation <input type="checkbox"/>
50BF-2	CB Closed		
	CB Open	No Operation <input type="checkbox"/>	No Operation <input type="checkbox"/>

3.1.1.1 Element Blocking

The CB Fail function can be blocked by Binary Input Inhibit. This functionality should be checked.

Element	BI Inhibits	NOTES
50BF-1		
50BF-2		

3.2 Trip/Close Circuit Supervision (74TCS, 74CCS)

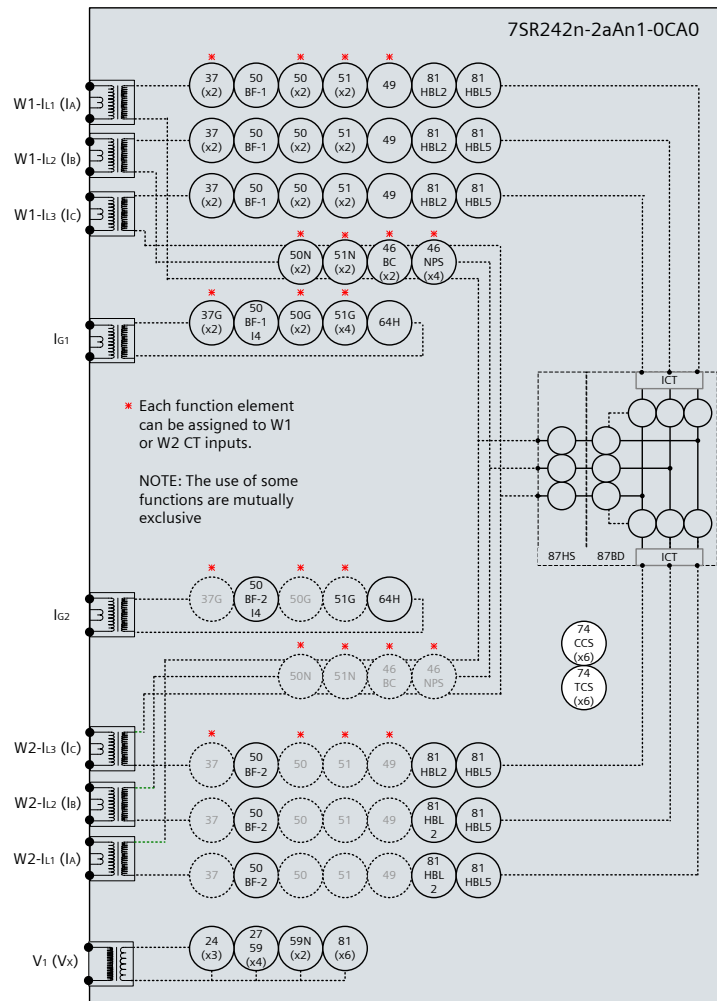

Figure 3-2 Trip Circuit Supervision

- Voltage Inputs: n/a
- Current Inputs: n/a
- Disable:
- Map Pickup LED: 74TCS-n/74CCS-n - Self Reset

The T/CCS-n Delay can be initiated by applying an inversion to the relevant status input and measured by monitoring of the alarm output.

TCS-n Delay setting	Measured
CCS-n Delay setting	Measured

3.3 Magnetising Inrush Detector (81HBL2)

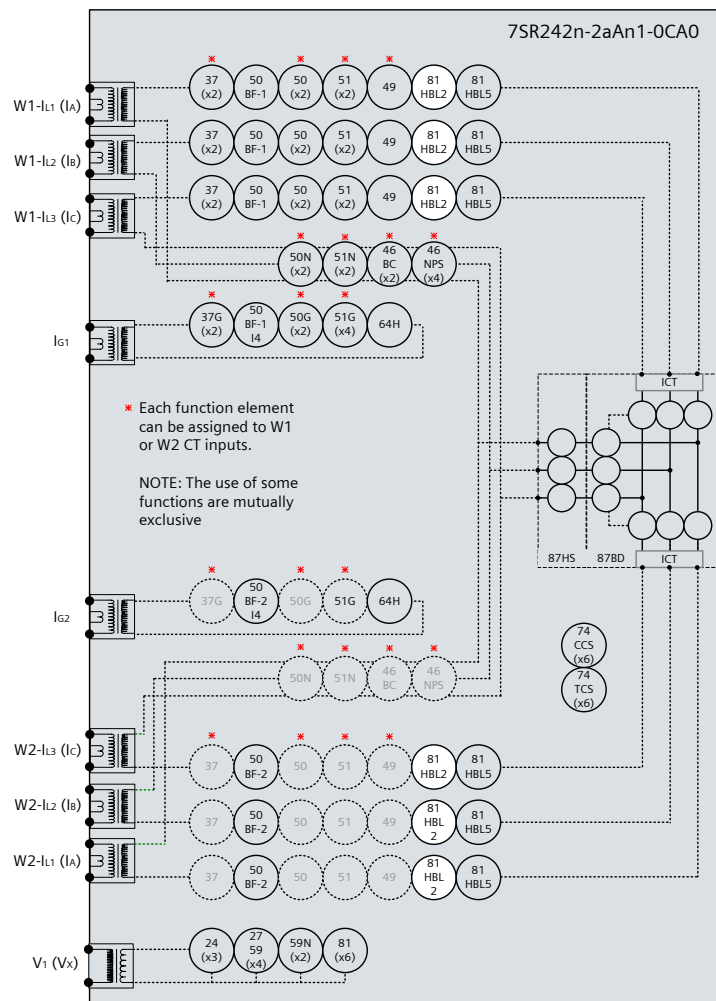

Figure 3-3 Magnetising Inrush Detector

Voltage Inputs:	n/a
Current Inputs:	W1-I _{L1} (I _A), W1-I _{L2} (I _B), W1-I _{L3} (I _C), or W2-I _{L1} (I _A), W2-I _{L2} (I _B), W2-I _{L3} (I _C)
Disable:	
Map Pickup LED:	

Logical operation of the harmonic blocking can be tested by injection of 2nd harmonic current (at 100Hz for 50Hz relay) to cause operation of the blocking signals. Note that injection of any level of 2nd harmonic alone on a current input will cause the block to be raised if the Cross or Phase blocking method is used since the harmonic content on this input is 100%, i.e. greater than setting. Full wave rectified current contains mostly 2nd harmonic and is the traditional method to generate it without advanced equipment.

If the Cross or Sum Blocking methods are used, fundamental frequency current can be injected into the other winding simultaneously to operate protection elements if required to test the blocking operation. Care should be taken that the thermal limits of the relay are not exceeded during these tests.

More advanced test equipment is required, with the facility to combine harmonic and fundamental frequencies of current, to test the accuracy of setting for current level of the blocking element. Note that the *81HBL2 Setting* is set as a fraction of the total current. e.g. 0.25A at 100Hz combined with 1A at 50Hz gives a 2nd harmonic content of 0.2 i.e. (0.25/(0.25+1.0)).

A compromise test can be made by the use of a diode to generate a half-wave rectified waveform from a sinusoidal source. The half-wave rectified current will contain a combination of fundamental and harmonic currents. The rectified waveform contains even harmonics higher than 2nd but the relationship between the 2nd harmonic current content, the fundamental component and the total RMS current is as shown below. Note that some protection elements can be set to operate on the RMS current or the Fundamental current and the applied values are different when non-sinusoidal waveforms are applied. The Inrush Detector setting is based on the ratio of 2nd harmonic to fundamental. This method is not suitable for use with constant current generating test sets such as modern digital equipment.

	Full Sine RMS	Rectified RMS Current	Fundamental component	2 nd Harmonic component	2 nd /Fundamental
Half Wave Rectified	1.0	0.5	0.5	0.212	0.424

Assuming that the *Gn 81HBL2 Setting* is less than 40%, inject half-wave rectified current at an RMS or Fundamental component level above the element setting to prove that the block is applied and the element is stable. Care should be taken that the thermal limits of the relay are not exceeded during these tests.

3.4 Overfluxing Detector (81HBL5)

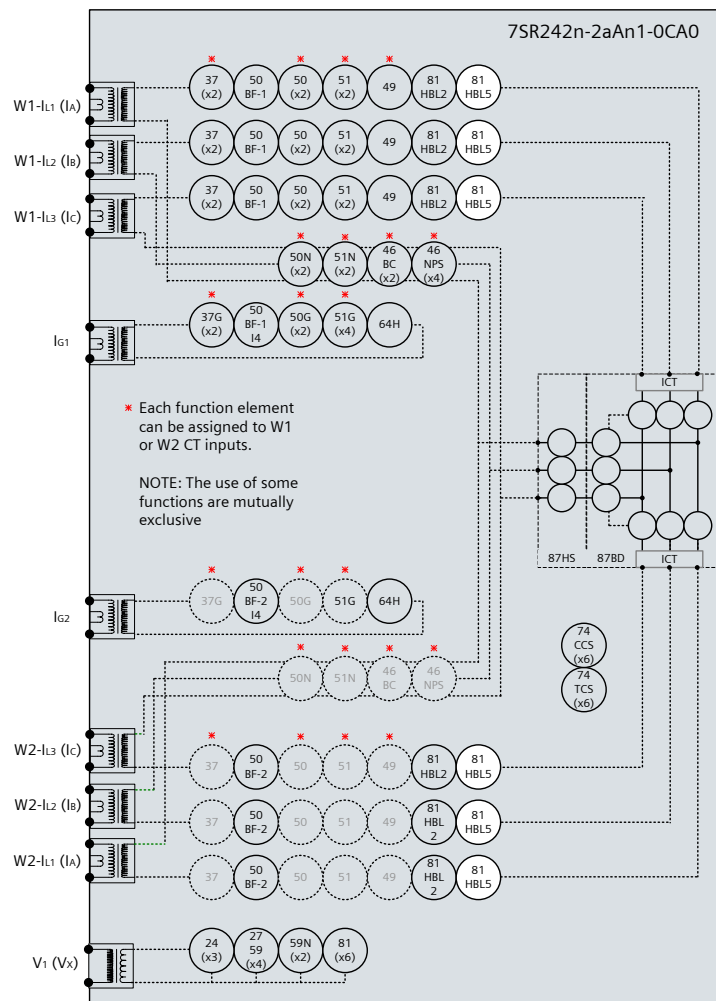

Figure 3-4 Magnetising Inrush Detector

Voltage Inputs:	n/a
Current Inputs:	W1-I _{L1} (I _A), W1-I _{L2} (I _B), W1-I _{L3} (I _C), or W2-I _{L1} (I _A), W2-I _{L2} (I _B), W2-I _{L3} (I _C)
Disable:	
Map Pickup LED:	

Logical operation of the harmonic blocking can be tested by injection of 5th harmonic current (at 250Hz for 50Hz relay) to cause operation of the blocking signals. Note that injection of any level of 5th harmonic alone on a current input will cause the block to be raised since the harmonic content on this input is 100%, i.e. greater than setting.

Fundamental frequency current can be injected into the other winding simultaneously to operate the 87BD or 87HS protection elements if required to test the blocking operation. Care should be taken that the thermal limits of the relay are not exceeded during these tests.

More advanced test equipment is required, with the facility to combine harmonic and fundamental frequencies of current, to test the level of the blocking element. Note that the *81HBL5 Setting* is set as a fraction of the total current. e.g. 0.25A at 250Hz combined with 1A at 50Hz gives a 5th harmonic content of 0.2 i.e. (0.25/(0.25+1.0)).

Section 4: Control & Logic Functions

4.1 Quick Logic

If this functionality is used, the logic equations may interfere with testing of other protection functions in the relay. The function of the Quick Logic equations should be tested conjunctively with connected plant or by simulation to assess suitability and check for correct operation on an individual basis with tests specifically devised to suit the particular application.

Section 5: Testing and Maintenance

7SR24 relays are maintenance free, with no user serviceable parts.

5.1 Periodic Tests

During the life of the relay, it should be checked for operation during the normal maintenance period for the site on which the product is installed. It is recommended the following tests are carried out:-

1. Visual inspection of the metering display
2. Operation of output contacts
3. Secondary injection of each element

5.2 Maintenance

Relay failure will be indicated by the 'Protection Healthy' LED being off or flashing. A message may also be displayed on the LCD. In the event of failure Siemens Protection Devices Ltd. (or the nearest Siemens office) should be contacted.

The relay should be returned as a complete unit. No attempt should be made to dismantle the unit to isolate and return only the damaged sub-assembly. It may however be convenient to fit the withdrawable relay to the outer case from a spare relay, to avoid the disturbance of relay panel wiring, for return to Siemens Protection Devices Ltd. The withdrawable relay should never be transported without the protection of the outer case.

5.3 Troubleshooting

Table 5-1 Troubleshooting Guide

Observation	Action
Relay does not power up.	Check that the correct auxiliary DC voltage is applied and that the polarity is correct.
Relay won't accept the password.	<p>The Password being entered is wrong. Enter correct password. If correct password has been forgotten, note down the Numeric Code which is displayed at the Change Password screen e.g.</p> <div style="border: 1px solid black; padding: 5px; width: fit-content; margin: 10px auto;"> <p style="text-align: center;">Change password = 1234567</p> </div> <p>To retrieve the password, communicate this code to a Siemens Protection Devices Ltd. representative.</p>
Protection Healthy LED flashes	General failure. Contact a Siemens Protection Devices Ltd. representative.
LCD screen flashes continuously.	<p>The LCD has many possible error messages which when displayed will flash continuously. These indicate various processor card faults.</p> <p>General failure. Contact a Siemens Protection Devices Ltd. representative.</p>
Backlight is on but no text can be seen.	Adjust the contrast.
Scrolling text messages are unreadable.	Adjust the contrast.
Relay displays one instrument after another with no user intervention.	<p>This is normal operation, default instruments are enabled. Remove all instruments from the default list and only add those that are required.</p> <p>(See Section 2: Settings and Instruments).</p>
Cannot communicate with the relay.	<p>Check that all of the communications settings match those used by ReyDisp Evolution.</p> <p>Check that the Tx and Rx fibre-optic cables are connected correctly. (Tx → Rx and Rx → Tx).</p> <p>Check that all cables, modems and fibre-optic cables work correctly.</p> <p>Ensure that IEC 60870-5-103 is specified for the connected port (COM1, COM2, COM3 or COM4).</p>
Relays will not communicate in a ring network.	<p>Check that the Data Echo setting on all relays is set to ON.</p> <p>Check that all relays are powered up.</p> <p>Check that all relays have unique addresses.</p>
Status inputs do not work.	<p>Check that the correct DC voltage is applied and that the polarity is correct.</p> <p>Check that the status input settings such as the pick-up and drop-off timers and the status inversion function are correctly set.</p>
Relay instrument displays show small currents or voltages even though the system is dead.	This is normal. The relay is displaying calculation noise. This will not affect any accuracy claims for the relay.

If the above checklist does not help in correcting the problem please contact the local Siemens office or contact PTD 24hr Customer Support,

Tel: +49 180 5247000,

Fax: +49 180 524 2471,

e-mail: support.energy@siemens.com.

Section 6: Relay Software Upgrade Instructions

6.1 General

Please read thoroughly all of the instructions supplied with the firmware upgrade before starting the download process.

- If you are loading firmware into a product that is already installed on site then follow the instructions in section 2, 3 and 4.
- Otherwise skip directly to section 3 to load firmware into the device.

6.2 Replacing firmware on a product installed on site

6.2.1 Identify Which Software Is Currently Loaded

With the relay connected to a suitable DC supply. Press CANCEL several times to ensure that you are at the root of the menu system. The relay will typically display the relay model name or circuit name.

On newer relay models press CANCEL and TEST to bring up the

SOFTWARE VERSION

menu. While still pressing TEST release the other keys. On older relay models press and hold CANCEL, press and hold TEST, press and hold ENTER then

"Build Version --> to view"

should appear. While still pressing ENTER release the other keys. Navigate to the software information screen using the TEST/RESET-> button.

The following typical information uniquely identifies a particular relay model. (Older relay models may only display a subset of this information).

6.2.2 Overall Software Information

Software Art No	This is the application software code used which may common to many relay variants.
Build Date	This is the date when the software was compiled.
Build Time	This is time when the software was compiled.
Code CRC	This is the CRC check code of the software code.
Boot Block Art No	This is the boot block software code responsible for loading in new application software code.

6.2.3 Product Configuration Information

Product Art No	This is the Products unique configuration article number.
Product Name	This is the Products unique model name.
Release Date	This is the date when this particular configuration was released.
Release Time	This is the time when this particular configuration was released.

6.2.4 Things To Do Before Loading New Firmware/Software

Ensure that a secure copy of relay settings is available as all settings will be lost during the code upload process. A hard copy is useful for checking purposes. It is usually possible to download the existing settings into Reydisp Evolution, save the file and then reload these settings into the relay following the upgrade. Reydisp will highlight any changes that it cannot automatically resolve for you to manually correct when re-installing the settings..

If the relay is in service then it is advisable to remove any TRIP LINKS to prevent in-advertent mal-operation due to incorrect settings being applied.

The attachments are password protected self extracting zip files to prevent email systems discarding them or modifying them which should be saved with the "EX" extension renamed to be "EXE". The password that is applied to this zip file is "REYROLLE" in capital letters.

6.2.5 Loading Firmware using front USB port

New firmware/software may be loaded via the USB port on the front Fascia.

Check compatibility of software before starting the procedure. The relay will not accept firmware/software for which the MLFB ordering code is not supported.

Installation instructions are provided with the upgrade firmware and should be studied before the procedure is attempted..

A USB connection between a PC and the relay front port is required.

The process may take several minutes to complete at which time the relay will restart.

Please make note of any warning or error messages that appear on the Reyfresh terminal window as the relay restarts.

6.2.6 Solving Software Upload Problems

The relay will auto detect the download baud rate and will use whatever baud rate set within Reyfresh. However the default and maximum baud rate of 460800 bits/sec is preferred

The download procedure requires a PC running Windows XP (Service Pack 3), Windows Vista or Windows 7.

When the relay restarts, messages appear on the LCD to confirm the number of I/O modules fitted, please press the ENTER key when requested if the details displayed are correct.

7SR242 Duobias

Multi-Function 2-Winding Transformer Protection Relay

Applications Guide

Document Release History

This document is issue 2017/12. The list of revisions up to and including this issue is:

2017/12	Software revision 2662H85001 R8e-7e
2017/08	Software revision 2662H85001 R8c-7d
2015/11	Text revisions to sections 2.2 and 6.6. Drawing revisions to Fig. 2-4, Fig. 6-7, Fig. 6-8 and Fig. 6-9. References to IEC61869-2 added.
2014/04	Revision to section 6.6
2013/01	Software revision 2662H85001 R7c-7b
2012/08	Addition of optional IEC 61850 communication protocol and Ethernet Interface.
2010/06	Revisions to trip/close circuit supervision diagrams
2010/02	Document reformat due to rebrand
2010/02	Third issue. Software revision 2662H80001 R4c-3
2008/07	Second issue. Software revision 2662H80001 R3d-2c.
2008/05	First issue

Contents

Document Release History	1
Contents	3
Section 1: Introduction	7
Section 2: Protection Functions	9
2.1 Overall Differential Protection (87).....	9
2.1.1 ICT Settings for Current Magnitude Balance	10
2.1.2 ICT Settings for Vector Group Correction	10
Interposing CT Selection Guide	11
2.1.3 Biased Differential (87BD) Settings	12
2.1.4 Differential Highset (87HS) Settings	14
2.1.5 Example 1 – New Installation (90MVA Yd11 Transformer)	15
Summary of Required Settings.....	17
2.1.6 Example 2 – Relay Replacement (Dyn1 Transformer) Using Existing CTs	22
Summary of Protection Settings	24
2.2 Instantaneous OC/EF (50/50G/50N)	25
2.3 Time Delayed OC/EF (51/51G/51N)	25
2.3.1 Selection of Over-current Characteristics	25
2.3.2 Reset Delay.....	27
2.4 High Impedance Restricted Earth Fault (64H).....	28
2.4.2 Establishing the Required Stabilising Resistor Value	30
2.4.3 Limiting Circuit Over-Voltages (Metrosils).....	30
2.5 Open Circuit (46BC).....	32
2.6 Negative Phase Sequence Overcurrent (46NPS)	32
2.7 Undercurrent (37).....	32
2.8 Thermal Overload (49).....	33
2.8.1 Settings Guidelines	33
2.9 Under/Over Voltage (27/59).....	35
2.10 Neutral Overvoltage (59N)	36
2.10.1 Application with Capacitor Cone Units.....	36
2.11 Under/Over Frequency (81)	37
2.12 Over Fluxing Protection (24).....	38
Section 3: CT Requirements	39
3.1 CT Requirement for Differential Protection.....	39
3.2 CT Requirements for High Impedance Restricted Earth Fault (64H)	40
Section 4: Control Functions	41
4.1 User Defined Logic	41
4.1.1 Auto-Changeover Scheme Example.....	41
Section 5: Supervision Functions	43
5.1 Inrush Detector (81HBL2)	43
5.2 Overfluxing Detector (81HBL5).....	44
5.3 Circuit Breaker Fail (50BF)	45
Example of Required Settings (e.g. HV CB).....	46
5.4 Trip Circuit Supervision (74TCS)	47
5.4.1 Trip Circuit Supervision Connections.....	47
5.4.2 Close Circuit Supervision Connections.....	49
Section 6: Application Considerations and Examples	51
6.1 The Effects of An In Zone Earthing Transformer	51
6.2 Protection of Star/Star Transformer With Tertiary Winding	53
6.3 Transformer with Primary Connections Crossed on Both Windings.....	54

6.4 Transformer with Primary Connections Crossed on One Winding	56
6.5 Protection of Auto Transformers	57
6.6 Reactor, Motor and Connections Protection	58
Section 7: Common Functions	59
7.1 Multiple Settings Groups	59
7.2 Binary Inputs	60
7.3 Binary Outputs	63
7.4 LEDs	63

List of Figures

Figure 2-1 Procedure for calculating Overall Differential Protection Settings	9
Figure 2-2: 87BD Characteristic	12
Fig. 2-3: Differential Highset Characteristic	14
Fig. 2-4 New Transformer Application	15
Figure 2-5: AC Connections - Example 1	15
Figure 2-6 ICT Settings – Example 1	16
Figure 2-7: Relay Currents - Star Winding Internal Earth	18
Figure 2-8: Relay Currents - Star Winding Internal Phase Fault	19
Figure 2-9: Relay Currents - Delta Winding Internal Earth Fault	20
Figure 2-10: Relay Currents - Delta Winding Internal Phase Fault	20
Figure 2-11 Relay Replacement	22
Figure 2-12: AC Connections - Example 2	22
Figure 2-13 Summary of ICT Settings	23
Figure 2-14 IEC NI Curve with Time Multiplier and Follower DTL Applied	26
Figure 2-15 IEC NI Curve with Minimum Operate Time Setting Applied	26
Figure 2-16 Overcurrent Reset Characteristics	27
Figure 2-17: REF Protection Applied to a Delta/Star Transformer	28
Figure 2-18: AC Connections: REF	28
Figure 2-19 Thermal Overload Settings	34
Figure 2-20 NVD Application	36
Figure 2-21 NVD Protection Connections	36
Figure 2-22 Load Shedding Scheme Using Under-Frequency Elements	37
Figure 3-1 CT Requirements	40
Figure 4-1 Example Use of Quick Logic	41
Figure 5-1 - Circuit Breaker Fail	45
Figure 5-2 - Single Stage Circuit Breaker Fail Timing	45
Figure 5-3 - Two Stage Circuit Breaker Fail Timing	46
Figure 5-4: Trip Circuit Supervision Scheme 1 (H5)	47
Figure 5-5: Trip Circuit Supervision Scheme 2 (H6)	48
Figure 5-6: Trip Circuit Supervision Scheme 3 (H7)	48
Figure 5-7 Close Circuit Supervision Scheme	49
Figure 6-1: Relay Currents – External Earth Fault with In Zone Earthing Transformer	51
Figure 6-2: Relay Currents – External Earth Fault with In Zone Earthing Transformer	52
Figure 6-3 7SR24 Applied to Yd Transformer with an In Zone Earthing Transformer	52
Figure 6-4: Protection of Star/Star Transformer with Tertiary	53
Figure 6-5 – AC Connections: Yd9, 90 ⁰ Transformer – Non-standard Secondary Connections	54
Fig. 6-6 AC Connections: Yd9, 90 ⁰ Transformer – Standard Secondary Connections	55
Fig. 6-7 Dyn11 Transformer with Reverse Phase Notation	56
Fig. 6-8: AC Connections for Auto-Transformer Overall Protection	57
Fig. 6-9: AC Connections for Auto-Transformer Overall and REF Protection	57
Fig. 6-10 AC Connections for Reactor and Connections Protection	58
Figure 7-1 Example Use of Alternative Settings Groups	59
Figure 7-2 Example of Transformer Alarm and Trip Wiring	60
Figure 7-3 – Binary Input Configurations Providing Compliance with EATS 48-4 Classes ESI 1 and ESI 2	62

List of Tables

Table 2-1 The Effect of ICT Selection on Protection Settings	21
--	----

Nomenclature

I_F	=	Fault current corresponding to the rated stability limit (primary Amps)
I_{Fint}	=	Maximum prospective internal fault current (primary Amps)
I_{MAG}	=	Secondary magnetising (exciting) current of current transformer at V_s volts.
I_{NLR}	=	Non-linear resistor (Metrosil) current.
I_s	=	Relay setting current
P.O.C.	=	Primary operate current (fault setting)
R_{CT}	=	Resistance of CT secondary winding.
R_L	=	Resistance of CT connection leads
R_{stab}	=	Resistance of stabilising resistor
T	=	Turns ratio of all current transformers (Primary turns / Secondary turns)
V_{Fint}	=	Maximum secondary internal fault voltage
V_k	=	Kneepoint voltage of the CT
V_s	=	Relay circuit setting voltage

Section 1: Introduction

The 7SR242 relay can be used to provide comprehensive protection for two winding or auto-transformers power transformers. The relay can also be used to provide differential protection for motors and reactors etc.

Basic functionality includes overall differential protection and two restricted earth fault (REF) protections i.e. REF protection for each transformer winding.

Optional current based and voltage based functionality can be used to provide integrated, comprehensive transformer protection.

Section 2: Protection Functions

This section provides guidance on the application and recommended settings of the 7SR24 protection functions.

2.1 Overall Differential Protection (87)

This section covers the transformer overall differential protections – the biased differential and high-set differential elements. Transformer design limitations necessitate that the protection CTs are located on the line side of the HV and LV windings, therefore the zone of differential protection covers both transformer windings.

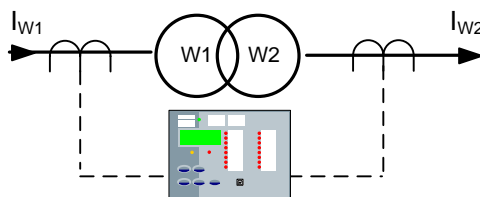

The application of differential protection to transformers is complicated by:

- The current magnitude change introduced by the transformer HV/LV turns ratio. The current ratio may also be variable due to the presence of an On-Load-Tap-Changer (OLTC).
- The transformer connections which may introduce a phase change between the currents flowing into each winding of the transformer.
- Magnetising inrush current which flows in only one winding of the transformer when energised.

Generally the procedure to calculate relay settings is carried out in the following order:

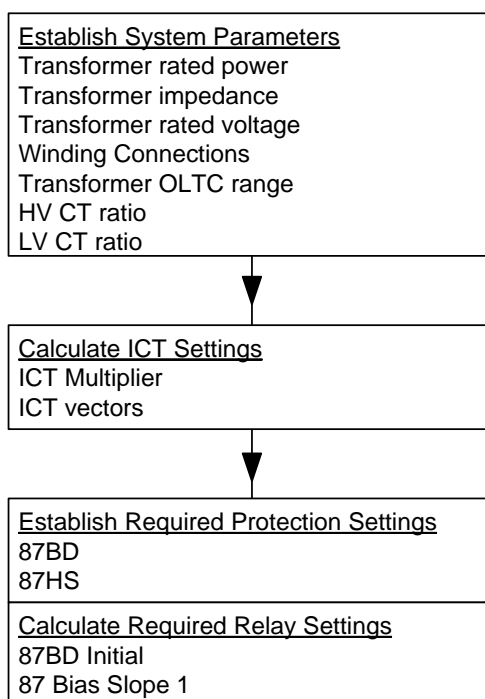

Figure 2-1 Procedure for calculating Overall Differential Protection Settings

2.1.1 ICT Settings for Current Magnitude Balance

Internal current multipliers are used to adjust the CT secondary currents to accommodate for any mismatch between the winding 1 and winding 2 CT ratios.

For load or through fault conditions the output of the ICT Multiplier for each winding must be equal, notwithstanding variations in the OLTC position. Where possible the output of each ICT Multiplier is set to 1A at transformer full load rating when the transformer OLTC is on its mid-tap position. At mid-tap a balanced relay should have virtually no differential currents, the bias currents will vary with the load level.

Balancing ICT Multiplier outputs (ICT_{OUT}) to 1A at transformer rating ensures that the relay operates at the levels indicated by its differential protection settings. However achieving balance at $ICT_{OUT} = 1$ is not always possible; here the effects on settings must be taken into account. The effect of applying $ICT_{OUT} < 1$ is to de-sensitise current dependent differential settings, applying $ICT_{OUT} > 1$ makes the effected elements more sensitive. To compensate for the resultant ICT_{OUT} value the following settings must be multiplied by ICT_{OUT} :

- 87HS Setting

- 87BD Initial

- 87BD 1st Bias Slope Limit

See examples in sections 0 and 2.1.6.

2.1.2 ICT Settings for Vector Group Correction

Internal interposing current transformers are used to correct the CT secondary current phase relationships in line with any phase change introduced by the transformer connections.

As a general rule, the phase angle **ICT Connection** setting to correct the phase angle difference is applied to the star side winding. A table showing the settings to apply for all standard transformer vector groups is included on the following page. The table assumes that all line CTs are 'star' connected.

Note that the choice of interposing CT vector group will modify the effective operating levels of the protection due to the current distribution for the various fault conditions – the effects on settings must be taken into account - see section 2.1.5.1.

Settings examples included in section 6 cover selected non-standard connection arrangements e.g. where the primary connections within the protected zone are crossed.

Interposing CT Selection Guide

Power Transformer Vector Group	HV Interposing CT Selection	LV Interposing CT Selection
Yy0, YNy0, Yyn0, YNyn0, Ydy0, Yndy0, Ydyn0, Yndyn0, Dz0	Ydy0,0°	Ydy0,0°
Yd1, YNd1	Yd1,-30°	Yy0,0°
Yd1, YNd1 + Earthing Transformer	Yd1,-30°	Ydy0,0°
Yy2, YNy2, Yyn2, YNyn2, Ydy2, YNdy2, Ydyn2, Yndyn2, Dz2	Ydy2,-60°	Ydy0,0°
Yd3, YNd3	Yd3,-90°	Yy0,0°
Yd3, YNd3 + Earthing Transformer	Yd3,-90°	Ydy0,0°
Yy4, YNy4, Yyn4, YNyn4, Ydy4, YNdy4, Ydyn4, Yndyn4, Dz4	Ydy4,-120°	Ydy0,0°
Yd5, YNd5	Yd5,-150°	Yy0,0°
Yd5, YNd5 + Earthing Transformer	Yd5,-150°	Ydy0,0°
Yy6, YNy6, Yyn6, YNyn6, Ydy6, YNdy6, Ydyn6, Yndyn6, Dz6	Ydy6,180°	Ydy0,0°
Yd7, YNd7	Yd7,150°	Yy0,0°
Yd7, YNd7 + Earthing Transformer	Yd7,150°	Ydy0,0°
Yy8, YNy8, Yyn8, YNyn8, Ydy8, YNdy8, Ydyn8, Yndyn8, Dz8	Ydy8,120°	Ydy0,0°
Yd9, YNd9	Yd9,90°	Yy0,0°
Yd9, YNd9 + Earthing Transformer	Yd9,90°	Ydy0,0°
Yy10, Yny10, Yyn10, YNyn10, Ydy10, YNdy10, Ydyn10, Yndyn10, Dz10	Ydy10,60°	Ydy0,0°
Yd11, Ynd11	Yd11,30°	Yy0,0°
Yd11, Ynd11 + Earthing Transformer	Yd11,30°	Ydy0,0°
Dy1, Dyn1	Yy0,0°	Yd11,30°
Dy1, Dyn1 + Earthing Transformer	Ydy0,0°	Yd11,30°
Dy3, Dyn3	Yy0,0°	Yd9,90°
Dy3, Dyn3 + Earthing Transformer	Ydy0,0°	Yd9,90°
Dy5, Dyn5	Yy0,0°	Yd7,150°
Dy5, Dyn5 + Earthing Transformer	Ydy0,0°	Yd7,150°
Dy7, Dyn7	Yy0,0°	Yd5,-150°
Dy7, Dyn7 + Earthing Transformer	Ydy0,0°	Yd5,-150°
Dy9, Dyn9	Yy0,0°	Yd3,-90°
Dy9, Dyn9 + Earthing Transformer	Ydy0,0°	Yd3,-90°
Dy11, Dyn11	Yy0,0°	Yd1,-30°
Dy11, Dyn11 + Earthing Transformer	Ydy0,0°	Yd1,-30°

1. Y or y denotes an unearthed star connection on the HV or LV side of the transformer.
2. YN or yn denotes an earthed star connection on the HV or LV side of the transformer.
3. D or d denotes a delta connection on the HV or LV side of the transformer respectively.
4. Z or z denotes a zigzag connection of the HV or LV side of the transformer respectively

2.1.3 Biased Differential (87BD) Settings

The 87BD elements provide differential protection for phase and earth faults. The limiting factors for protection sensitivity are dictated by the need to ensure protection stability during load or through fault conditions.

Magnitude restraint bias is used to ensure the relay is stable when the transformer is carrying load current and during the passage of external (out of zone) fault current. As the bias current increases the differential current required for operation increases.

Harmonic bias is used to prevent relay operation during magnetising inrush current into one winding when the transformer is first energised.

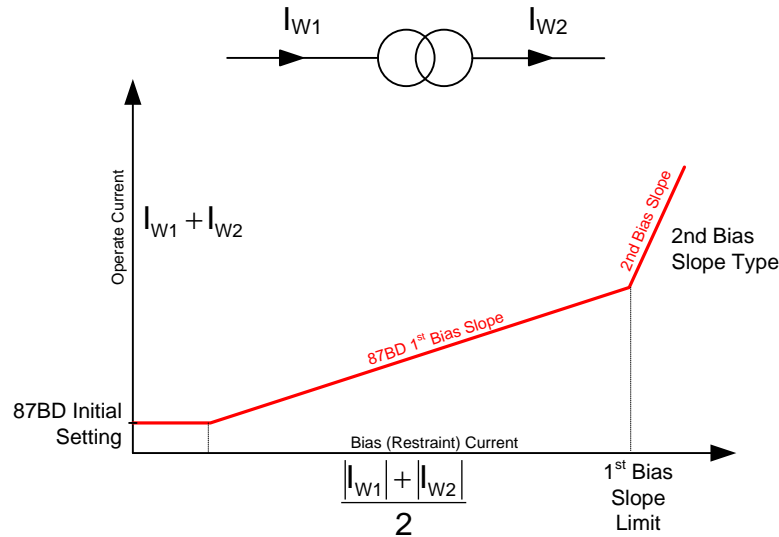

Figure 2-2: 87BD Characteristic

87BD Initial Setting (0.1 to 2.0 x I_n)

This setting is selected to ensure stability in the presence of CT and relay errors when low levels of bias current are present i.e. low load levels.

This is the minimum level of differential current at which the relay will operate. Typically this setting is chosen to match the on load tap-change range. For example if the tap change range is +10% to -20%, a setting of 0.3I_n is selected.

87BD 1st Bias Slope Setting (0.0 to 0.7)

Steady state unbalance current will appear in the differential (operate) circuit of the relay due to the transformer tap position, relay tolerance and to CT measurement errors. The differential current will increase with increasing load or through fault current in the transformer so, to ensure stability, the differential current required for operation increases with increasing bias current. The bias slope expresses the current to operate the relay relative to the biasing (restraint) current.

The Bias slope setting chosen must be greater than the maximum unbalance, it is selected to ensure stability when through fault or heavy load current flows in the transformer and the tap changer is in its extreme position.

The recommended setting is 1 x the tap change range. As the protection is optimised around the centre tap position then using the total tap change range includes for a 100% safety margin, this provides contingency for CT and relay tolerances. For example if the tap change range is +10 to -20%, the overall range is 30% so a 0.3x setting is chosen.

87BD 1st Bias Slope Limit Setting (1 to 20 x In)

Above this setting the ratio of differential current to bias current required for operation is increased.

When a through fault occurs, saturation of one or more CTs may cause a transient differential current to be detected by the relay. The bias slope limit is chosen to ensure the biased differential function is stable for high through fault currents coincident with CT saturation. This setting defines the upper limit of the bias slope and is expressed in multiples of nominal rated current i.e. the lower the setting the more stable the protection.

The three phase through fault current can be estimated from the transformer impedance. For a typical grid transformer having a 15% impedance, the maximum through fault will be $1/0.15 = 6.66 \times$ rating. A setting value is chosen that introduces the extra bias at half of the three phase through fault current level of the transformer, so $6.66/2 = 3.33$ and a setting of 3 would be selected as the nearest lower setting available.

87BD 2nd Bias Slope Type (Line, Curve)

87BD 2nd Bias Slope Setting (1.0 to 2.0 – applied to ‘Line’ only)

These settings are chosen to ensure the biased differential function is stable for high through fault currents coincident with CT saturation.

87BD Inrush Action

Harmonic bias is used to prevent relay operation during magnetising inrush current into one winding when the transformer is first energised.

The recommended setting is **ENABLED** - see section 5.1.

87BD Overfluxing Action

This setting can be used to prevent operation of the 87BD elements in the presence of allowable over-fluxing conditions - see section 5.2.

87BD Time Delay Setting

A 5ms setting is recommended where the circuit is cabled to ensure stability during resonant conditions.

2.1.4 Differential Highset (87HS) Settings

The element operates on the differential current measured by the relay.

The 87HS element is generally applied as an unrestrained differential element to provide fast tripping for heavy internal faults.

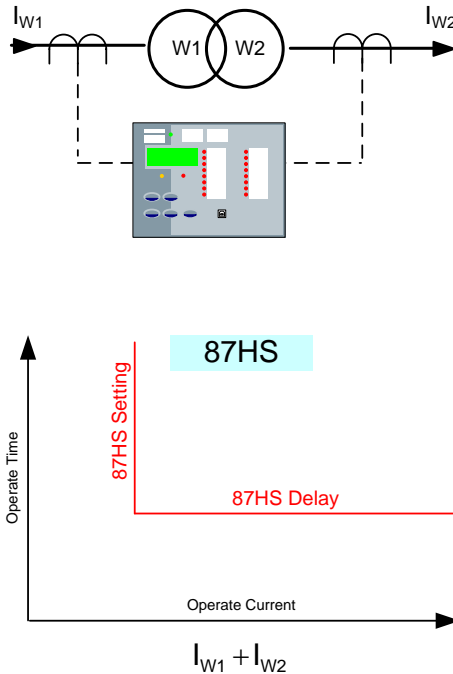

Fig. 2-3: Differential Highset Characteristic

87HS Setting (1 to 30 x I_n)

The 87HS element is set as low as possible but not less than the maximum three phase through fault current and not less than half the peak magnetizing inrush current.

For almost all applications a setting of 7 or 8 x I_n has shown to be sufficiently sensitive for internal faults as well as providing stability during external faults and transient system conditions.

A Differential Highset Setting of 7 x I_n will be stable for a peak magnetizing inrush levels of 14 x rated current.

Smaller transformers generally will have lower impedance and therefore greater three phase through fault levels and magnetizing inrush currents. A setting of 8 x can be used as *CT saturation is reduced as system X/R is usually very low and the peak level of magnetising current does not usually ever exceed 16 x rating.*

87HS Delay Setting

A 5ms setting is recommended to compensate for transient overreach.

87HS Inrush Action

87HS Overfluxing Action

These functions are set to 'Disabled' unless specifically required by the application.

2.1.5 Example 1 – New Installation (90MVA Yd11 Transformer)

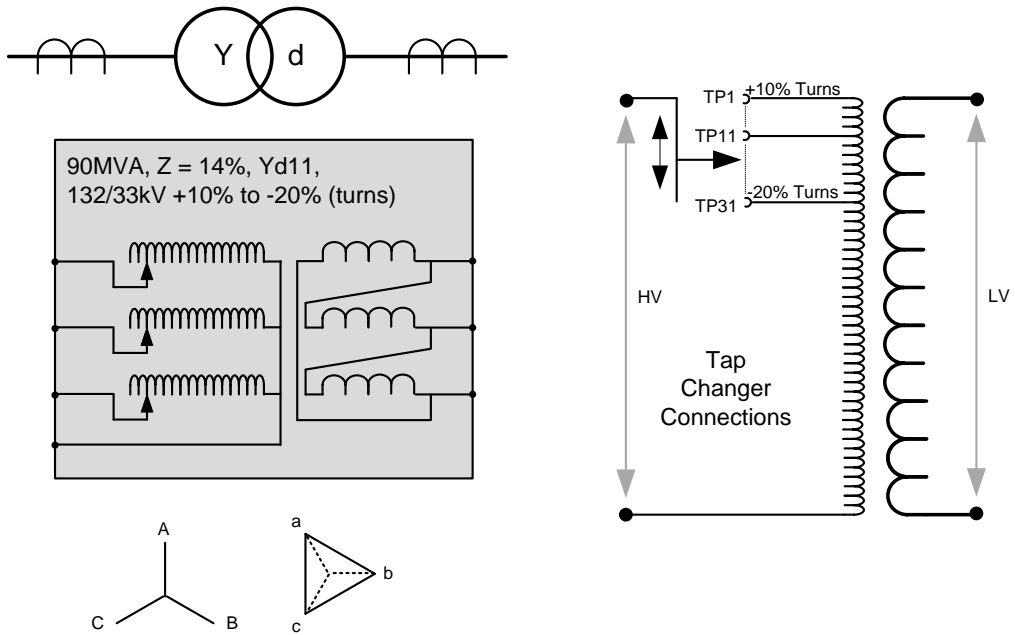
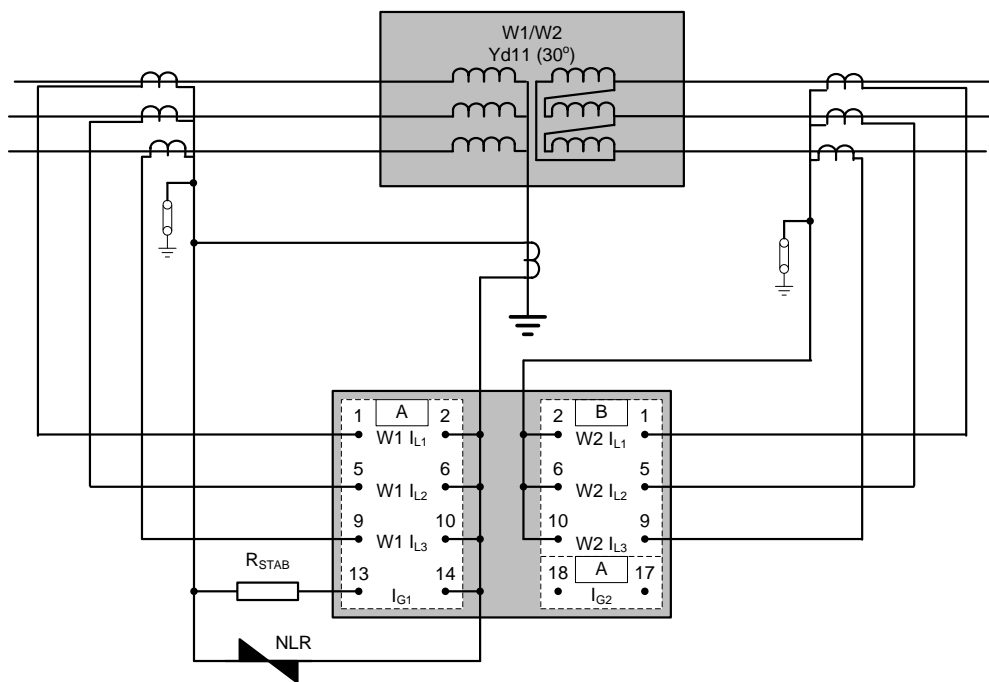

Fig. 2-4 New Transformer Application



NOTES

- CTs shown wired to 1A relay inputs
- REF protection shown on Star winding
- R_{STAB} = REF Series Stabilising resistor
- NLR = REF Non-linear (voltage limiting) resistor

Figure 2-5: AC Connections - Example 1

Summary of Required Settings

CT/VT CONFIG >

W1 Phase Input	1A
W1 Phase CT Ratio	400:1
W2 Phase Input	1A
W2 Phase CT Ratio	1600:1

FUNCTION CONFIG>

Gn Differential	Enabled
Gn Inrush Detector	Enabled

DIFFERENTIAL PROT'N >

Gn W1 ICT Multiplier	1.02
Gn W1 ICT Connection	Yd11
Gn W2 ICT Multiplier	1.06
Gn W2 ICT Connection	Yy0

(Note that the above settings produce $ICT_{OUT} = 1.00$)

DIFFERENTIAL PROT'N > 87BD >

Gn 87 BD Element	Enabled	
Gn 87BD Initial:	$0.3 \times I_n$	$(0.3 \times ICT_{OUT})$
Gn 87BD 1st Bias Slope:	0.3x	$(OLTC = +10\% \text{ to } -20\%)$
Gn 87BD 1st Bias Slope Limit:	$4 \times I_n$	$(1/0.14 \times 0.5 = 3.6 \times ICT_{OUT})$
Gn 87BD 2nd Bias Slope Type:	Line	(Default value)
Gn 87BD 2nd Bias Slope:	1.5x	(Default value)
Gn 87BD Delay:	0.005s	
Gn 87BD Inrush Action:	Inhibit	
Gn 87BD Overfluxing Action:	Off	

DIFFERENTIAL PROT'N > 87HS >

Gn 87HS Element	Enabled	
Gn 87HS Setting:	$8 \times I_n$	$(> I_{3PH \text{ THRU FAULT i.e. } 1/0.14 = 7.14 \times ICT_{OUT})$
Gn 87HS Delay:	0.005s	
Gn 87HS Inrush Action:	Off	
Gn 87HS Overfluxing Action:	Off	

SUPERVISION > INRUSH DETECTOR >

Gn81HBL2 Element	Enabled	
Gn 81HBL2 Bias	Cross	(Default value)
Gn 81HBL2 Setting	$0.2 \times I$	(Default value)

OUTPUT CONFIG>OUTPUT MATRIX>

87BD	BOn, Ln
87HS	BOn, Ln

OUTPUT CONFIG>BINARY OUTPUT CONFIG>

CB1 Trip Contacts	BOn
CB2 Trip Contacts	BOn

2.1.5.1 Example 1 – Further Analysis

Having established settings to ensure stability under load, transient and external fault conditions the following considers the operating levels for internal faults. The 'fault setting' for internal fault conditions is affected by the **ICT Multiplier** and **ICT Connection** settings applied:

W1 Internal Earth Fault

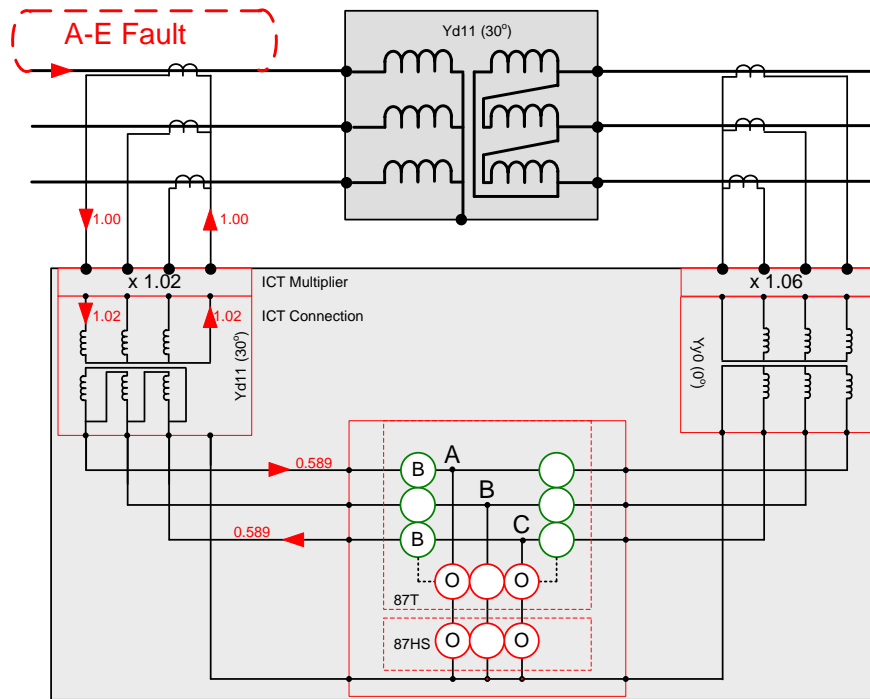

Figure 2-7: Relay Currents - Star Winding Internal Earth

Notes

- A- E fault causes current to flow in the A and C elements
- The Yd ICT connection reduces current flow by a factor of $1/\sqrt{3}$
- Relay may indicate A and C faults

W1 Internal Phase-Phase Fault

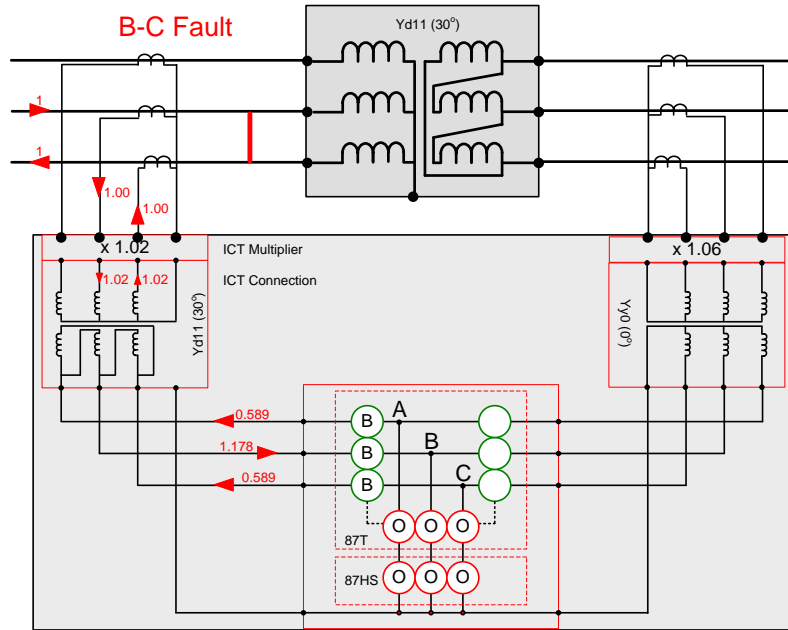

Figure 2-8: Relay Currents - Star Winding Internal Phase Fault

Notes

B - C fault causes current to flow in the A, B and C elements

The Yd ICT connection causes a 1:2:1 current distribution and introduces a $1/\sqrt{3}$ multiplying factor.

Relay may indicate three phase fault

W2 Internal Earth Fault

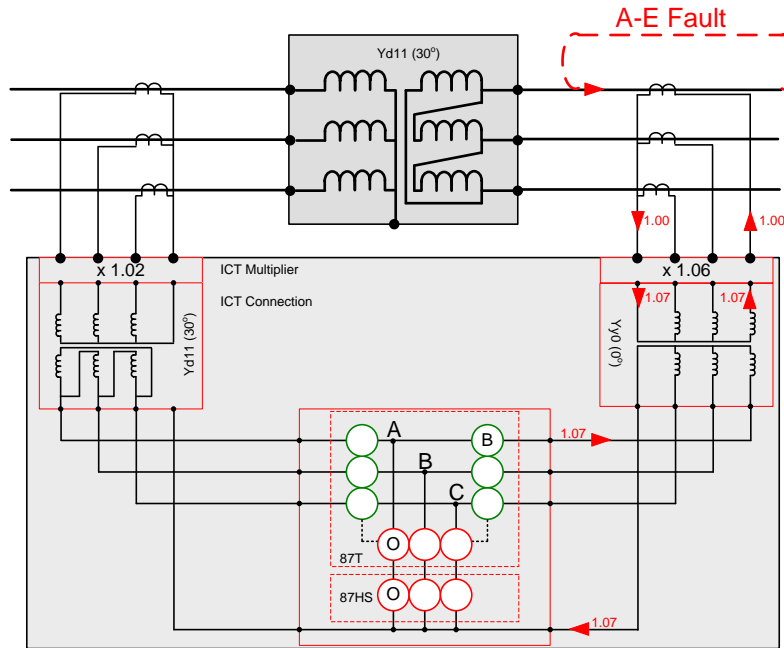

Figure 2-9: Relay Currents - Delta Winding Internal Earth Fault

W2 Internal Phase-Phase Fault

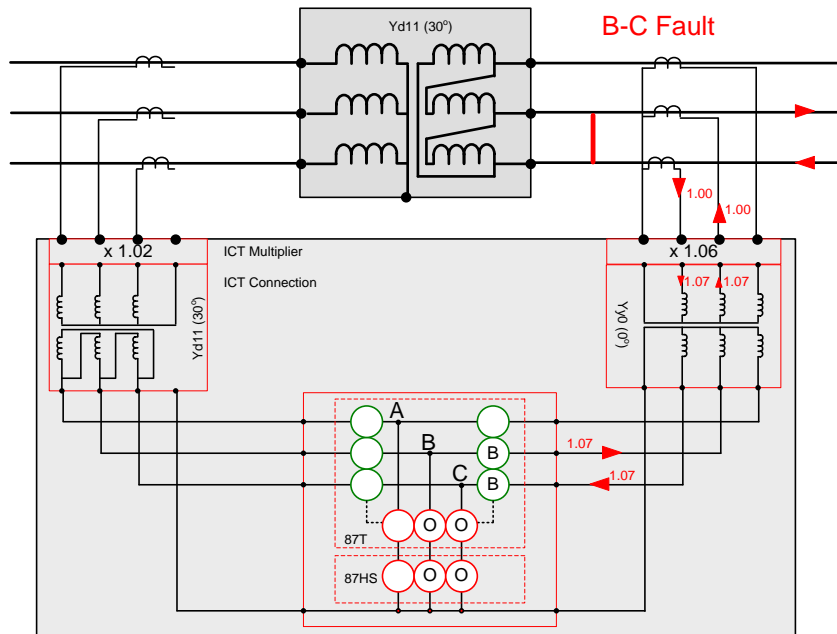

Figure 2-10: Relay Currents - Delta Winding Internal Phase Fault

Table 2-1 summarises the implications of using Yd or Yy interposing CTs.

Table 2-1 The Effect of ICT Selection on Protection Settings

CT Secondary Current	HV (ICT: Yd11, x 1.02) W1 ICT _{OUT} =	LV (ICT: Yy0, x 1.06) W2 ICT _{OUT} =
<u>3-Phase</u> A = 1A B = 1A C = 1A	A = 1.02A B = 1.02A C = 1.02A	A = 1.06A B = 1.06A C = 1.06A
<u>B – C</u> A = 0 B = 1A C = 1A	A = 0.589A B = 1.178A C = 0.589A	A = 0 B = 1.06A C = 1.06A
<u>A – E</u> A = 1A B = 0 C = 0	A = 0.589A B = 0 C = 0.589A	A = 1.06A B = 0 C = 0

The above analysis covers current distributions for internal faults. The table illustrates that the Yd ICT has the effect of:

- Modifying the amplitude of the ICT_{OUT} currents
- Changing current distribution

The above factors must be considered during any analysis of protection operations and indications.

A similar analysis can be carried for external (through) fault conditions. However as the protection settings already ensured stability for the maximum through fault condition (3-phase fault) this is not necessary.

2.1.6 Example 2 – Relay Replacement (Dyn1 Transformer) Using Existing CTs

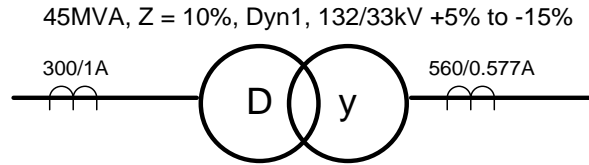

Figure 2-11 Relay Replacement

It is recommended to wire all line CTs in star when connecting to the 7SR24 relay. Where the 7SR24 is used to replace an older biased differential relay the existing CTs will often be re-used. In this example it is recommended that the existing LV line CTs connected in 'delta' are reconnected as 'star'.

Usually the interposing CTs associated with older schemes can be removed as both the vector group and current magnitude compensation functions are carried out within the 7SR24. This requires ICT settings to be programmed into the relay to correct for differences before the currents are applied to the differential algorithm. When the relay is in balance the phase angle of the currents applied to each phase of the differential algorithm will be in anti-phase.

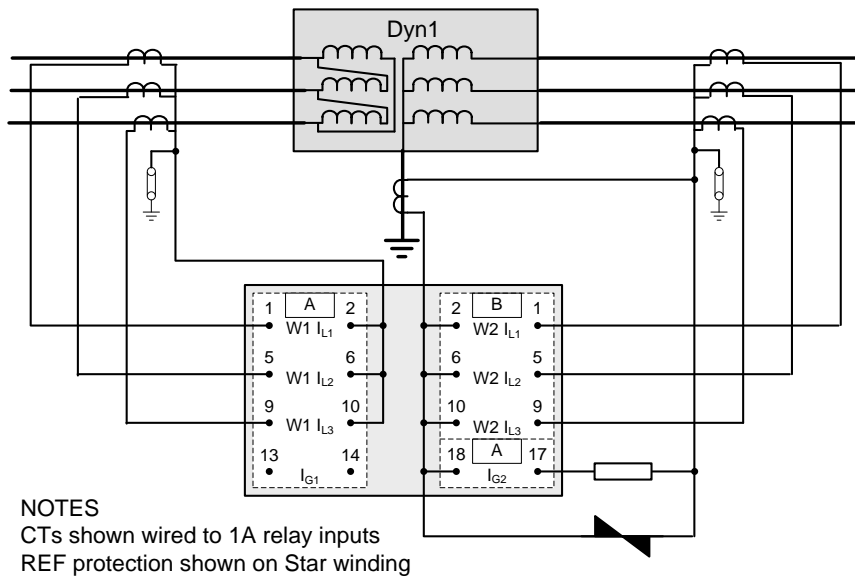

Figure 2-12: AC Connections - Example 2

Step 1 – Connection of CTs

Remove all interposing CTs from the secondary circuit. Connect all line CT secondary wiring in star.

$$\text{HV load current} = \frac{45 \times 10^6}{\sqrt{3} \times 132,000} = 196.8\text{A} \quad \text{Re-use 300/1A CTs.}$$

$$\text{LV load current} = \frac{45 \times 10^6}{\sqrt{3} \times 33,000} \times 0.95 = 747.9\text{A} \quad \text{Re-use 560/0.577A CTs.}$$

Step 2 – Selection of Interposing CT Multiplier Settings

$$\text{HV Secondary current} = \frac{196.8}{300} = 0.66\text{A} \quad \text{HV ICT Multiplier} = 1/0.66 = 1.54$$

$$\text{LV Secondary current} = \frac{747.9}{560/0.577} = 0.77\text{A} \quad \text{LV ICT Multiplier} = 1/0.77 = 1.30$$

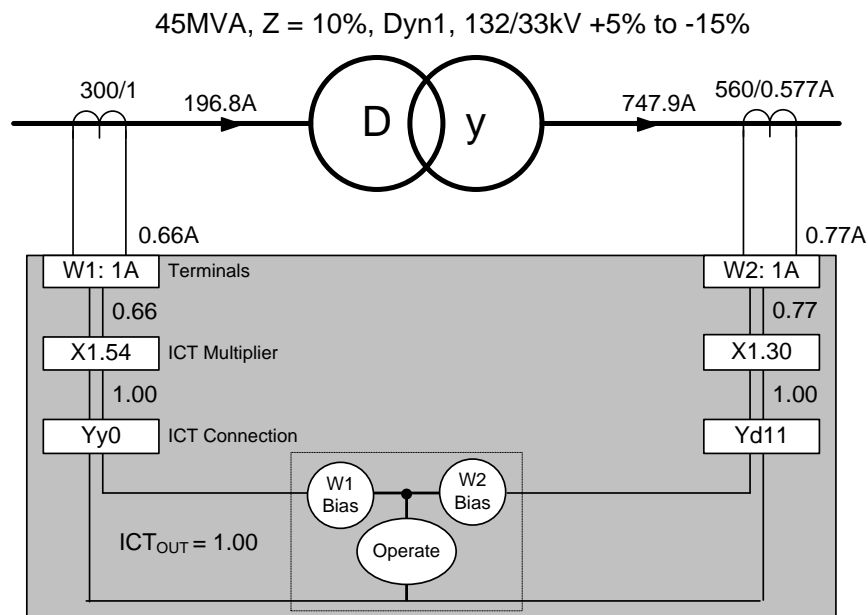

Figure 2-13 Summary of ICT Settings

Summary of Protection Settings

CT/VT CONFIG >

W1 Phase Input	1A
W1 Phase CT Ratio	300:1
W2 Phase Input	1A
W2 Phase CT Ratio	560:0.58

FUNCTION CONFIG>

Gn Differential	Enabled
Gn Inrush Detector	Enabled

DIFFERENTIAL PROT'N >

Gn W1 ICT Multiplier	1.54
Gn W1 ICT Connection	Yy0
Gn W2 ICT Multiplier	1.30
Gn W2 ICT Connection	Yd11

(Note that the above settings produce $ICT_{OUT} = 1.00$)

DIFFERENTIAL PROT'N > 87BD >

Gn 87 BD Element	Enabled	
Gn 87BD Initial:	0.2 x In	(0.2 x ICT_{OUT})
Gn 87BD 1st Bias Slope:	0.2x	(OLTC = +5% to -15%)
Gn 87BD 1st Bias Slope Limit:	5 x In	(1/0.1 x 0.5 = 5 x ICT_{OUT})
Gn 87BD 2nd Bias Slope Type:	Line	(Default value)
Gn 87BD 2nd Bias Slope:	1.5x	(Default value)
Gn 87BD Delay:	0.005s	
Gn 87BD Inrush Action:	Inhibit	
Gn 87BD Overfluxing Action:	Off	

DIFFERENTIAL PROT'N > 87HS >

Gn 87 HS Element	Enabled	
Gn 87HS Setting:	10 x In	(> $I_{3PH\ THRU\ FAULT}$ i.e. 1/0.1 = 10 x ICT_{OUT})
Gn 87HS Delay:	0.005s	
Gn 87HS Inrush Action:	Off	
Gn 87HS Overfluxing Action:	Off	

SUPERVISION > INRUSH DETECTOR >

Gn 81HBL2 Element	Enabled	
Gn 81HBL2 Bias	Cross	(Default value)
Gn 81HBL2 Setting	0.2 x I	(Default value)

OUTPUT CONFIG>OUTPUT MATRIX>

87BD	BOn, Ln
87HS	BOn, Ln

OUTPUT CONFIG>BINARY OUTPUT CONFIG>

CB1 Trip Contacts	BOn
CB2 Trip Contacts	BOn

2.2 Instantaneous OC/EF (50/50G/50N)

Instantaneous overcurrent can be applied to protect the HV terminals against high fault currents. The current setting applied must be above the maximum 3-phase through fault level of the transformer to ensure grading with the LV overcurrent protection.

Where the setting applied is below the magnetising inrush current of the transformer then inrush blocking (81HBL2) should be enabled.

A sensitive instantaneous HV earth fault setting can be considered where the transformer winding connections do not allow the through flow of zero sequence current. Time delayed (DTL) operation can also be considered where the transformer switch on magnetising inrush current may cause mal-operation. This will be identified during commissioning. An increased operate current or high impedance operation can also be considered.

2.3 Time Delayed OC/EF (51/51G/51N)

The time delayed element can provide a number of shaped characteristics. The selectable Inverse definite minimum time lag (IDMTL) and Definite Time Lag (DTL) characteristics provide protection for phase and earth faults.

As these protections are used as back-up protections discrete relays are often installed. To reduce cost and complexity it may be considered acceptable to implement the backup protection using elements within the main protection relay. The relay is self supervised and this can be used as justification for allowing the backup protection to be included as part of the main differential protection relay.

The following elements can be included:

- Three phase over current with IDMTL (IEC or ANSI) or DTL operate characteristic (51)
- Derived earth fault with IDMTL (IEC or ANSI) or DTL operate characteristic (51N)
- Measured earth fault with IDMTL (IEC or ANSI) or DTL operate characteristic (51G)

Each of the above elements can be selected to winding 1 or winding 2 CT inputs.

The time delayed characteristics are used to provide grading with other relays or fuses.

Earth fault elements can be used to provide system protection or standby earth fault protection of an earthing resistor.

2.3.1 Selection of Over-current Characteristics

Where the relay operate time must be co-ordinated with other time delayed relays on the system, the operating characteristic is selected to be the same type as the other relays. Often a normally inverse (NI) characteristic is applied, however extremely inverse curves (EI) can provide improved grading with fuses or moulded case circuit breakers.

To optimise the grading capability of the relay additional time multiplier, 'Follower DTL' (Figure 2-14) or 'Minimum Operate Time' (Figure 2-15) settings can be applied.

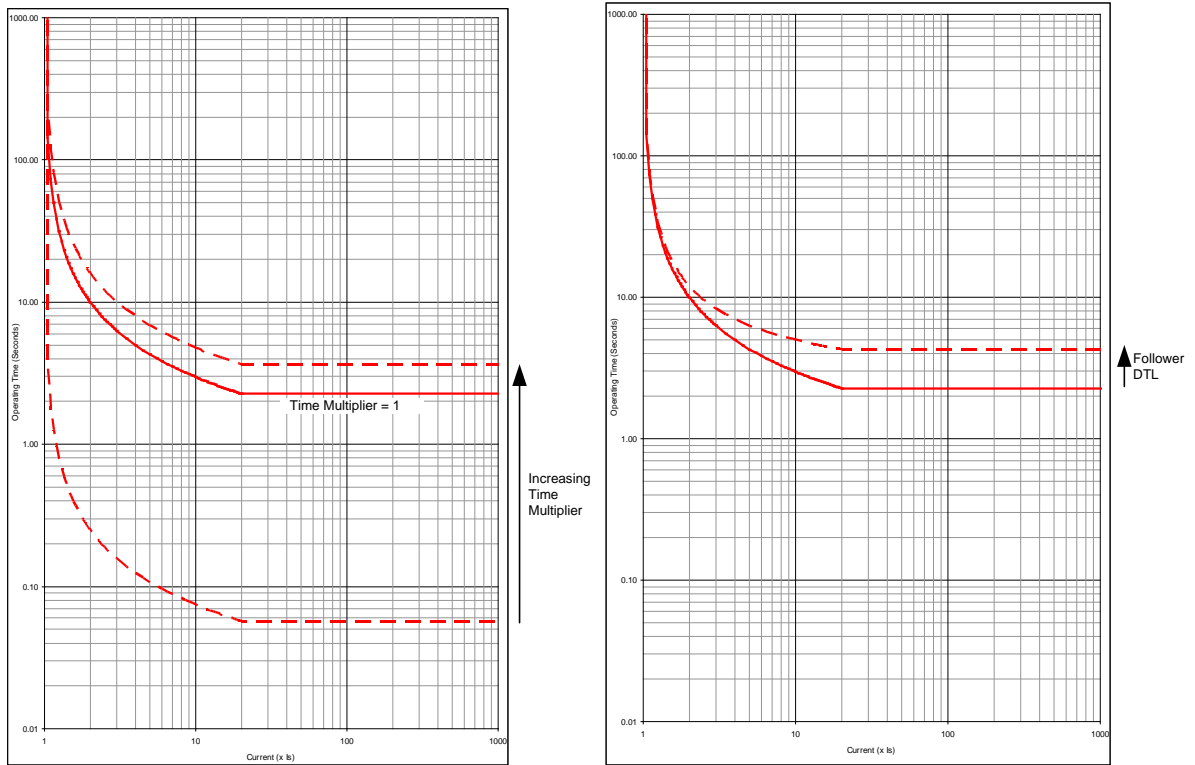

Figure 2-14 IEC NI Curve with Time Multiplier and Follower DTL Applied

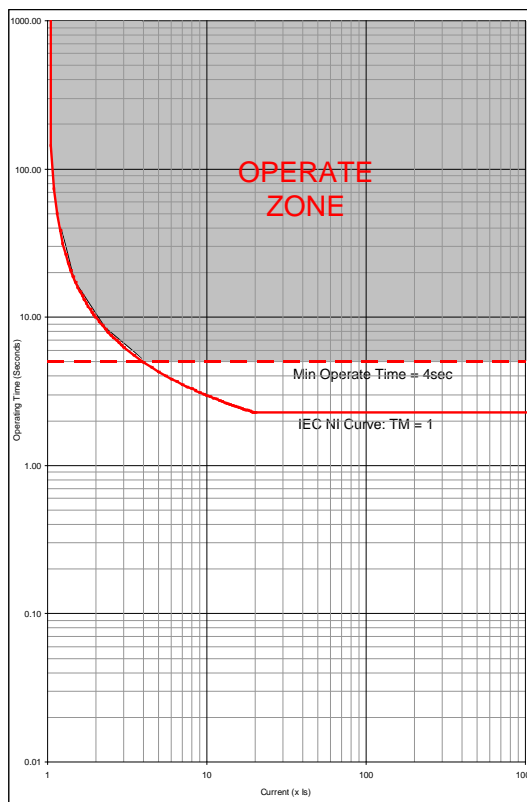

Figure 2-15 IEC NI Curve with Minimum Operate Time Setting Applied

2.3.2 Reset Delay

Faults in plastic insulated cables or compound-filled joint boxes can be intermittent or 'flashing' faults – the insulant melts and temporarily reseals the fault for a short time after which the insulation fails again.

The repeating process of the fault often causes electromechanical disc relays to "ratchet" up and eventually trip the faulty circuit if the reset time of the relay was longer than the time between successive flashes.

To ensure time grading is maintained with other relays on the system a DTL or shaped (ANSI only) reset characteristic can be selected for all overcurrent and earth fault elements.

Where the substation feeds an outgoing overhead line network, particularly where reclosers are installed, instantaneous resetting is desirable to ensure that, on multiple shot reclosing schemes, correct grading between the substation incomer relays and the relays associated with the reclosers is maintained.

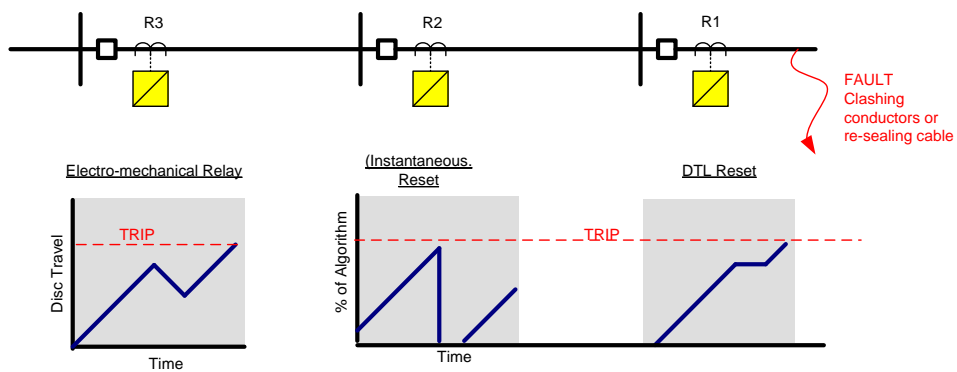

Figure 2-16 Overcurrent Reset Characteristics

2.4 High Impedance Restricted Earth Fault (64H)

Restricted earth fault (REF) protection can be applied to either or both windings of the transformer. The 7SR24 provides a high impedance REF (64H) element for each transformer winding. Low leakage reactance CTs (Class PX) are required for use with high impedance protection systems.

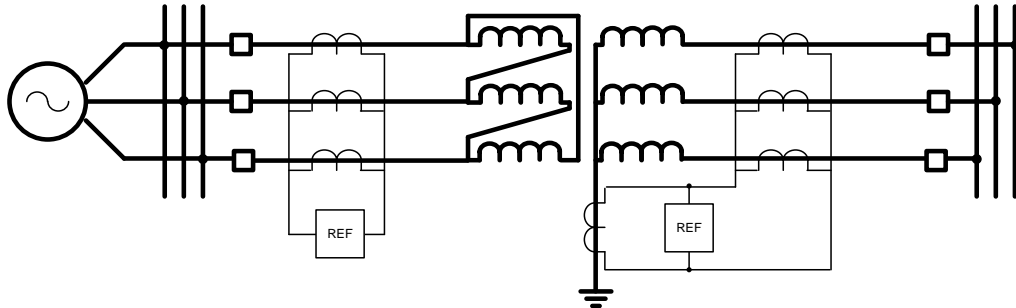

Figure 2-17: REF Protection Applied to a Delta/Star Transformer

The zone of REF protection is defined by the position of the CTs and/or the transformer winding. REF protection provides a low operate current (fault setting) for in zone earth faults and stability during external faults.

REF is more sensitive than overall biased differential protection (87BD) to earth faults it can protect against faults for a greater portion of the transformer windings or where the impedance in the earth fault path is relatively high. For a solidly earthed star winding, the REF function is roughly twice as sensitive in detecting a winding earth fault, than biased differential protection.

The stability of high impedance REF schemes depends upon the operate voltage setting being greater than the voltage which can appear across the element during the maximum assigned through fault conditions. To provide the required operating voltage an external 'stabilising' resistor is wired in series with the 64H current measuring input. A non-linear resistor is connected in parallel to protect the relay circuit against high over-voltages. REF connections are shown in Figure 2-18.

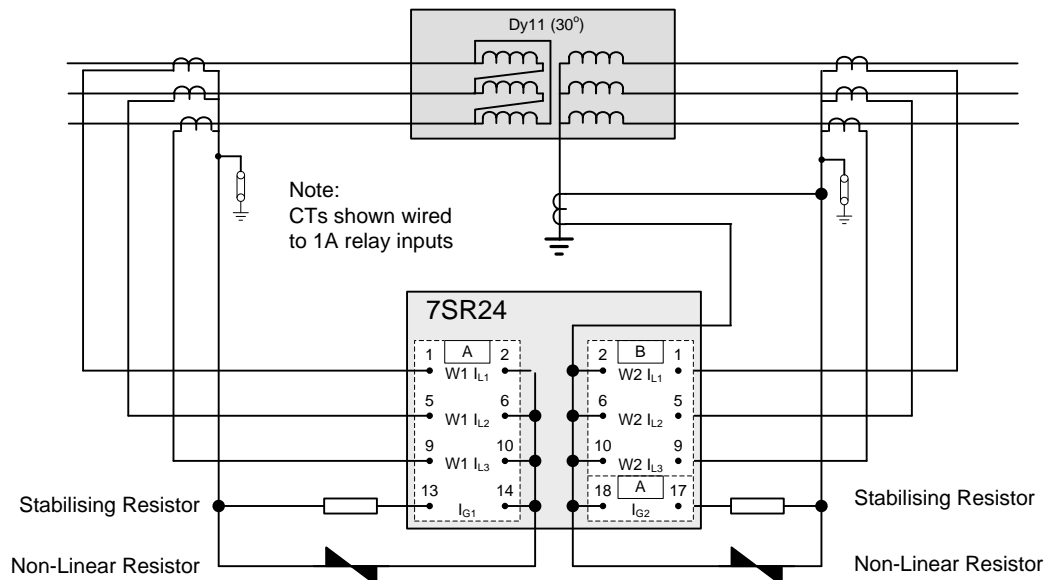

Figure 2-18: AC Connections: REF

The operating voltage of the relay/stabilising resistor combination is calculated taking into account: the r.m.s. value of the symmetrical component of the transformer through fault current

The relay current setting is calculated taking into account: the required operate level for in-zone earth faults (fault setting).

2.4.1.1 Stability Requirement

The use of class PX CTs (IEC61869-2) ensures steady state CT errors are minimised. Transient CT errors are caused by CT saturation e.g. due to high currents flowing at times of through faults. Where CT saturation conditions are different in each CT this will cause differential current to flow in the CT secondary circuit wiring. The highest level of differential current will flow when one set of CTs is fully saturated, providing zero output and all other CTs transform normally.

When fully saturated the CT secondary provides no current and it behaves as a resistance in the secondary circuit. Differential current in the secondary circuit will flow either through this 'resistance' or through the relay. A 'stabilising' resistance is added in series with the relay input to ensure that the operate voltage at the current setting is greater than the maximum voltage which can appear across the element/stabilising resistor during the maximum assigned through fault conditions. It is assumed that any earthing resistor can become short-circuit.

This maximum voltage that can appear across the relay circuit can be determined by a simple calculation which makes the following assumptions:

One current transformer is fully saturated making its excitation current negligible.

The remaining current transformers maintain their ratio.

The resistance of the secondary winding of the saturated CT together with the leads connecting it to the relay circuit terminals constitute the only burden in parallel with the relay.

The minimum required relay operate voltage setting (V_s) is given by:

$$V_s \geq I_F(R_{CT} + R_L) \times T \quad (1)$$

To ensure high speed relay operation the relay circuit operating voltage should be selected in accordance with the stability requirement above (equation 1), also, the operate voltage should not exceed 0.5 x CT knee point voltage (V_k).

$$V_s \leq \frac{V_k}{2} \quad (2)$$

2.4.1.2 Operation Requirement

For internal faults the relay will operate at the calculated 'Voltage Setting' V_s . This operating voltage will also be applied across the CT secondary windings of all the CT secondaries connected in parallel with the relay. This voltage will drive a magnetising current in each of the CT secondary windings and this must be added to the relay operate current when calculating the operate current of the high impedance protection scheme.

$$\text{In general: P.O.C.} = (I_s + I_{NLR} + \sum I_{MAG})/T \quad (3)$$

2.4.1.3 Consideration of Component Thermal Ratings

When the relay circuit operates for an internal fault the circuit breakers are opened and the flow of fault current ceases.

Where a CB fails to trip then fault current will flow in the high impedance circuit until the fault is cleared by the operation of CB failure or back up protection. The thermal rating of the relay circuit components should then be considered.

Alternatively the high impedance circuit can be arranged to short circuit the external components after operation.

2.4.2 Establishing the Required Stabilising Resistor Value

The relay burden need not be considered as it is effectively negligible relative to the burden of the stabilising resistor. The setting (operate) voltage (V_s) across the Relay and Stabilising Resistor at the Relay operating current (I_s):

$$R_{STAB} = \frac{V_s}{I_s} \quad (4)$$

Stabilising Resistor power rating must:

Be sufficient for continuous operation at the circuit operate voltage (V_s):

$$P_{CONT} \geq (I_s)^2 \times R_{stab}$$

Short time rated to withstand I_{Fint} for the maximum fault clearance time. For a failed circuit breaker condition the back up protection clearance time is considered – typically a one second rating is sufficient.

$$P_{1SEC} \geq \frac{V_{Fint}^2}{R_{stab}} \quad \text{Where: } V_{Fint} \geq \sqrt[4]{(V_K^3 \times R_{stab} \times I_{Fint})} \times 1.3$$

Where I_{Fint} is not known, the breaking capacity current of the Circuit Breaker can be used.

2.4.3 Limiting Circuit Over-Voltages (Metrosils)

Non-linear resistors are connected in parallel with the relay circuit to limit the peak voltage developed across the high impedance components during internal faults to a 'safe' level below 3kV peak. Where a Metrosil is not connected in circuit the peak voltage can be calculated from:

$$V_{PK} = 2 \times \sqrt{2 \times V_K \times ((I_{Fint} \times R_{stab}) - V_K)}$$

Notwithstanding the above calculation SPDL recommend that a Metrosil is always fitted in the high impedance relay circuit

The use of non-linear resistors manufactured by Metrosil is recommended. The operate characteristic is defined by:-

Voltage characteristic: $V = C.I^\beta$ For dc or instantaneous values.

$$I_{rms} = 0.52 \left(\frac{V_{rms} \sqrt{2}}{C} \right)^{\frac{1}{\beta}} \quad \text{For applied sinusoidal voltages}$$

$$V_{peak} = 1.09 C (I_{rms})^\beta \quad \text{For applied sinusoidal currents}$$

Where: C and β are Metrosil constants

When supplied as discrete components 7XG14 Metrosils can be specified as single or three phase, with a diameter of 75mm or 150mm and have constant 'C' values of 450, 900 or 1000.

Metrosils of diameter 75mm have a thermal rating of 8kJ. Where a higher thermal rating is required Metrosils of 150mm diameter should be used.

The chosen Metrosil 'C' value must;

- 1) Ensure negligible current flows through the Metrosil at relay operate voltage (V_s), and,
- 2) Limit over-voltages for operational and safety reasons i.e. $1.09C (I_{Fint}^\beta) < 3kV$

A 'C' value of 450 is generally acceptable where the relay operate voltage is less than 100V, a 'C' value of 1000 is recommended for settings above 100V.

Metrosil short time power rating must;

Be sufficient to dissipate the heat created by the flow of maximum secondary internal fault current. The Metrosil is chosen so that it can withstand I_{Fint} for the maximum fault clearance time. For a failed circuit breaker condition the back up protection clearance time must be considered – typically a one second rating is sufficient.

$$P_{1SEC} \geq \frac{4}{\pi} \times I_F \times T \times V_K$$

2.5 Open Circuit (46BC)

Used to detect an open circuit condition e.g. an OLTC failure.

There will be little or no fault current and so the differential protection elements will not detect the condition. However the condition can be detected because there will be a high content of NPS (unbalance) current present.

An NPS / PPS ratio > 50% will result from an open circuit condition.

A time delay can be applied to prevent operation for transitory effects.

2.6 Negative Phase Sequence Overcurrent (46NPS)

The Negative Phase Sequence (NPS) over current is intended to be used to detect uncleared system faults and conditions such as broken primary connections that may produce significant NPS current.

This unbalance may cause rotating plant such as generators or motors to overheat and fail.

This may also be used to monitor the state of the tap changer and alarm for faults with diverter resistors or switches.

Typical Settings are 5 to 10% for Tap Changer alarm and 10 to 15% for system fault or broken conductor.

2.7 Undercurrent (37)

Where current decreases beneath defined levels this can indicate low load or CB open conditions, it can also be used to indicate that no current is flowing.

The undercurrent function is used:

- As a fault current check i.e. that no fault current continues to flow and that an auto-isolation sequence may safely be initiated.

- As a check that a CB has opened – this can be used in addition to or in place of CB auxiliary switch indications.

2.8 Thermal Overload (49)

Thermal protection is provided to supplement the Winding Temperature device. This function provides a general overload thermal protection i.e. not a winding hot spot protection.

Outputs can be assigned to both alarm and trip levels. The default settings are recommended if transformer data is not available, these settings correspond to the lowest level of thermal withstand for an oil filled transformer.

Transformer overloading can result in:-

- Reduced transformer life expectancy.
- Lower insulation voltage withstand due to degradation of the insulation.
- Increased mechanical stress due to expansion.
- Gas bubble production in the mineral oil at extreme levels of overload.

2.8.1 Settings Guidelines

49 Overload Setting

The **49 Overload Setting** is expressed as a multiple of the relay nominal current and is equivalent to the factor $k.I_B$ as defined in the IEC255-8 thermal operating characteristics. It is the value of current above which 100% of thermal capacity will be reached after a period of time. This setting should be set to 110% of the secondary current flowing when the transformer is at its full rating and on its minimum voltage tap position.

49 Time Constant Setting

A transformer may be required to temporarily run overloaded e.g. 150% of rating for two hours or 200% of rating for one hour.

The thermal time constants required to match these specifications are:

150% for two hours Time constant = 178 minutes

200% for one hour Time constant = 186 minutes

These times are applicable to an overload occurring from no load with the transformer at ambient temperature.

The actual tripping time will depend on the loading level prior to the overload occurring.

The operate time can be calculated from:

$$\text{Time to trip } t(\text{mins}) = \tau \times \ln \left[\frac{I^2}{I^2 - (I_\theta)^2} \right]$$

The steady state % thermal capacity used can be calculated from:

$$\% \text{ thermal capacity used} = \left[\frac{I^2}{(I_\theta)^2} \right] \times 100$$

Where:

I = applied current in terms of $x I_n$

I_θ = thermal pick-up setting $x I_n$

49 Capacity Alarm Setting

This setting can be used to provide an alarm prior to a thermal trip occurring and is typically set to about 80 to 90 % of thermal capacity. The thermal capacity alarm can be mapped to a binary output wired to the control system.

Example

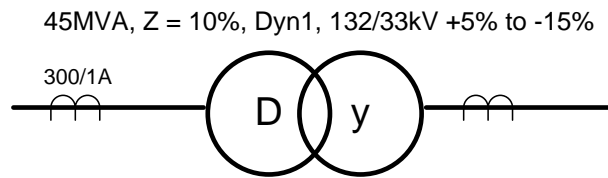

Figure 2-19 Thermal Overload Settings

1. In fig. 2-19 the direction of power flow is HV to LV. If W1 input is connected to HV CTs (as is usual) then set **49 Select = W1**. The transformer loss current and harmonic currents are then included in the thermal calculation.
2. **FUNCTION CONFIG>Gn Thermal: Enabled**
CURRENT PROT'N>THERMAL>Gn49 Thermal Overload: Enabled.
3. **CURRENT PROT'N>THERMAL>49 Overload Setting:**

$$\text{Maximum Primary Full Load current} = \frac{45000}{\sqrt{3} \times 132 \times 0.85} = 231.5A$$

Secondary Current = 231.5A/300 = 0.772A. The thermal function should not trip for currents below this value.

A setting of 110% is used to include a margin of safety.

Therefore **49 Overload Setting** = 0.85 x I_n (I_θ) (1.10 x 0.772)

4. The time constant to apply will depend upon the transformer overload specification, but in this case it was decided to set a time constant of 178 minutes. This will allow an overload of 150% from ambient for about two hours before a trip is issued.
5. The capacity alarm is a useful function and therefore it is set to 90%. The current required to reach this 90% figure should be calculated. It is important not to alarm for current within the normal loading range of the transformer.

The steady state thermal capacity = I² / I_θ² x 100%

For this example: 90% = I² / I_θ² x 100%. I = 0.806 x I_n and this level is above the maximum full load current of 0.772 x I_n.

The above provides guidelines only as setting philosophies differ. Alternative protection setting groups may be used to match transformer loading for temporary or emergency overloads, wide variations in winter/summer loading or if a cooling failure (pump or fan) occurs. The thermal settings applied will differ in each Setting Group and will be made appropriate to the specific load conditions.

2.9 Under/Over Voltage (27/59)

Power system under-voltages may occur due to:

- System faults.
- An increase in system loading,
- Non-energized power system e.g. loss of an incoming transformer

During normal system operating conditions regulating equipment such as transformer On Load Tap Changers (OLTC) and generator Automatic Voltage Regulators (AVR) ensure that the system runs within acceptable voltage limits.

7SR24 under-voltage/DTL elements can be used to detect abnormal under-voltage conditions due to system overloads. Binary outputs can be used to trip non-essential loads - returning the system back to its normal operating levels. This 'load shedding' should be initiated via time delay elements so avoiding operation during transient disturbances. An under voltage scheme (or a combined under frequency/under voltage scheme) can provide faster tripping of non-essential loads than under-frequency load shedding so minimising the possibility of system instability.

Where a transformer is supplying 3-phase motors a significant voltage drop e.g. to below 80% may cause the motors to stall. An under-voltage element can be set to trip motor circuits when the voltage falls below a preset value so that on restoration of supply an overload is not caused by the simultaneous starting of all the motors. A time delay is required to ensure voltage dips due to remote system faults do not result in an unnecessary disconnection of motors.

To confirm presence/loss of supply, the voltage elements should be set to values safely above/below that where a normal system voltage excursion can be expected. The switchgear/plant design should be considered. The 'Dead' level may be very near to the 'live' level or may be significantly below it. The variable hysteresis setting allows the relay to be used with all types of switchgear.

System over-voltages can damage component insulation. Excessive voltage may occur for:

- Sudden loss of load
- A tap changer run-away condition occurs in the high voltage direction,
- Generator AVR equipment malfunctions or
- Reactive compensation control malfunctions.

System regulating equipment such as transformer tap changers and generator AVRs may correct the overvoltage – unless this equipment mal-functions. The 7SR24 overvoltage/DTL elements can be used to protect against damage caused by system over-voltages.

If the overvoltage condition is small a relatively long DTL time delay can be used. If the overvoltage is more severe then another element, set at a higher pickup level and with a shorter DTL can be used to isolate the circuit more quickly. Alternatively, elements can be set to provide alarm and tripping stages, with the alarm levels set lower than the tripping stages.

The use of DTL settings allows a grading system to be applied to co-ordinate the network design, the regulating plant design, system plant insulation withstand and with other overvoltage relays elsewhere on the system. The DTL also prevents operation during transient disturbances.

The use of IDMTL protection is not recommended because of the difficulty of choosing settings to ensure correct co-ordination and security of supply.

2.10 Neutral Overvoltage (59N)

Neutral Overvoltage Displacement (Residual Overvoltage) protection is used to detect an earth fault where little or no earth current flows.

This can occur where a transformer feeder has been tripped at its HV side for an earth fault, but the circuit is still energised from the LV side via an unearthed transformer winding. Insufficient earth current would be present to cause a trip, but residual voltage would increase significantly; reaching up to 3-times the normal phase-earth voltage level.

If Neutral Overvoltage protection is used, it must be suitably time graded with other protections in order to prevent unwanted tripping for external system earth faults.

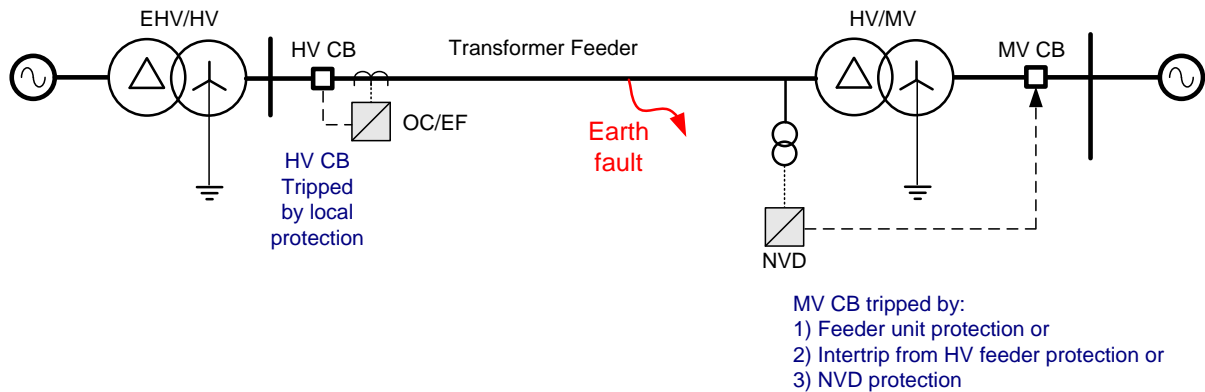

Figure 2-20 NVD Application

Typically NVD protection measures the residual voltage ($3V_0$) directly from an open delta VT or from capacitor cones – see fig. 2.13-2 below.

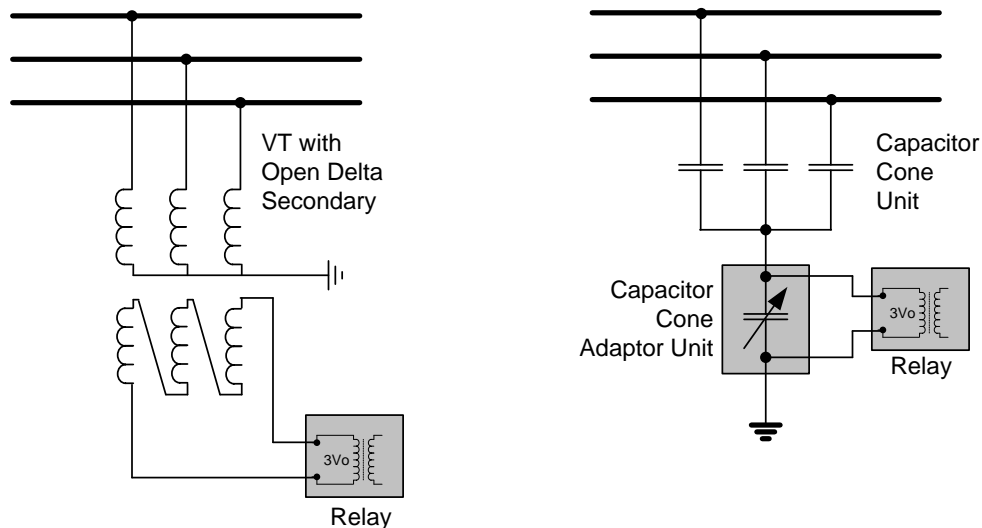

Figure 2-21 NVD Protection Connections

2.10.1 Application with Capacitor Cone Units

Capacitor cones provide a cost effective method of deriving residual voltage. The wide range of capacitor cone component values used by different manufacturer's means that the relay cannot be connected directly to the cones.

The external adaptor unit contains parallel switched capacitors that enable a wide range of values to be selected using a DIL switch and hence the Capacitor Cone output can be scaled to the standard relay input range.

2.11 Under/Over Frequency (81)

During normal system operation the frequency will continuously vary over a relatively small range due to the changing generation/load balance. Excessive frequency variation may occur for:

Loss of generating capacity, or loss of mains supply (under-frequency): If the governors and other regulating equipment cannot respond to correct the balance, a sustained under-frequency condition may lead to a system collapse.

Loss of load – excess generation (over-frequency): The generator speeds will increase causing a proportional frequency rise. This may be unacceptable to industrial loads, for example, where the running speeds of synchronous motors will be affected.

In the situation where the system frequency is falling rapidly it is common practise to disconnect non-essential loads until the generation-load balance can be restored. Usually, automatic load shedding, based on under-frequency is implemented. Under-frequency relays are usually installed on the transformer incomers of distribution or industrial substations as this provides a convenient position from which to monitor the busbar frequency. Loads are disconnected (shed) from the busbar in stages until the frequency stabilises and returns to an acceptable level.

The 7SR24 has six under/over frequency elements (optional).

An example scheme may have the first load shedding stage set just below the nominal frequency, e.g. between 49.0 - 49.5Hz. A time delay element would be associated with this to allow for transient dips in frequency and to provide a time for the system regulating equipment to respond. If the first load shedding stage disconnects sufficient plant the frequency will stabilise and perhaps return to nominal. If, however, this is not sufficient then a second load shedding stage, set at a lower frequency, will shed further loads until the overload is relieved. This process will continue until all stages have operated. In the event of the load shedding being unsuccessful, a final stage of under-frequency protection should be provided to totally isolate all loads before plant is damaged, e.g. due to overfluxing.

An alternative type of load shedding scheme would be to set all under-frequency stages to about the same frequency setting but to have different length time delays set on each stage. If after the first stage is shed the frequency doesn't recover then subsequent stages will shed after longer time delays have elapsed.

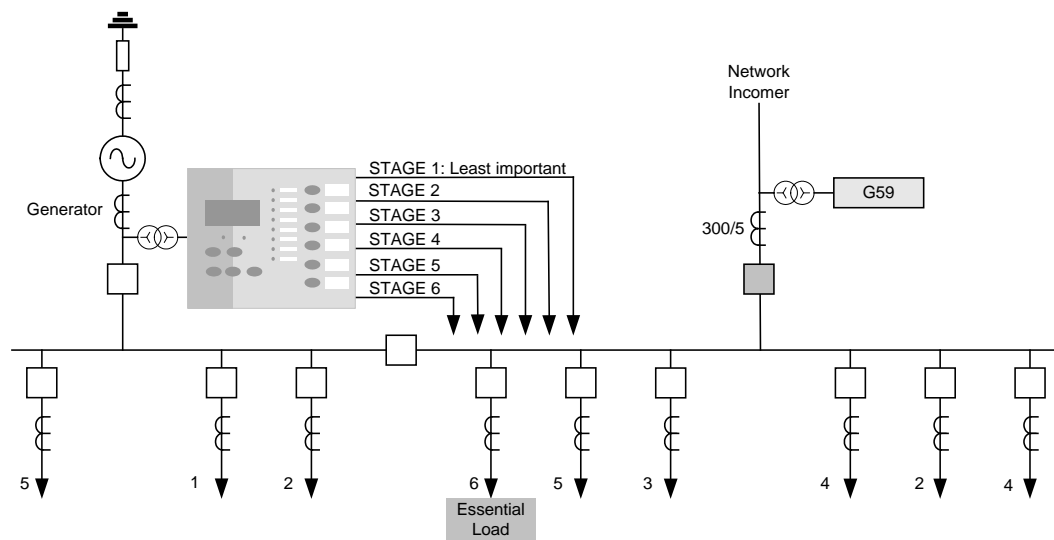

Figure 2-22 Load Shedding Scheme Using Under-Frequency Elements

2.12 Over Fluxing Protection (24)

An under-frequency condition at nominal voltage can cause over-fluxing (or over-excitation) of the transformer. Excess flux can cause transformer core saturation and some of the flux will radiate as leakage flux through the transformer tank. This leakage flux causes eddy currents and the I^2R losses from these currents heat the transformer tank and can cause overheating.

Overfluxing protection is applied to generator step-up transformers and other plant which may be subject to this condition.

This function measures the ratio of voltage to frequency (V/f) applied the transformer to determine operation.

The relay has two types of V/f characteristics:

- User Definable Inverse curve
- Two Independent Definite Time Lag elements(DTL)

User Definable V/f Curve

As the leakage flux will cause overheating, an inverse type curve provides an appropriate match to the over fluxing withstand characteristics of a transformer.

The relay includes a user definable curve. Where the transformer manufacturer has provided an over-fluxing withstand curve the user can define up to seven points to provide correlation between the relay characteristic and transformer withstand curves.

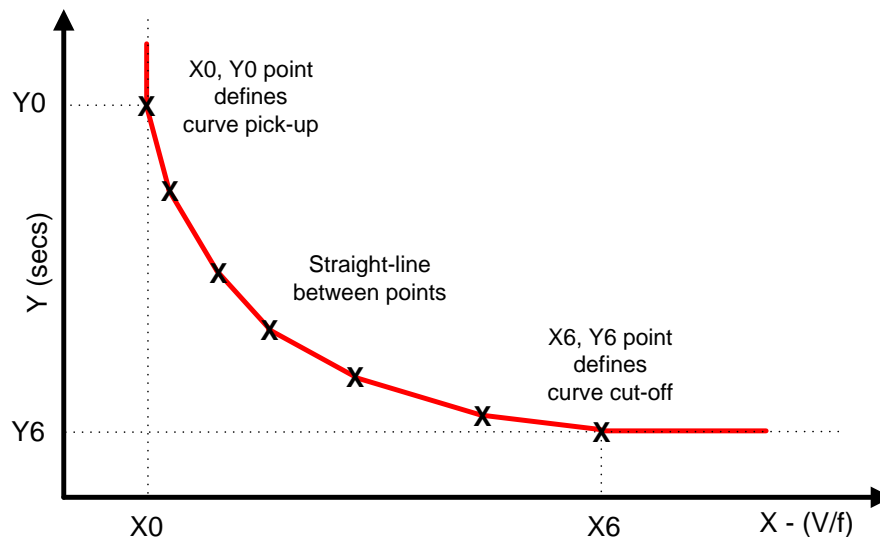

Two Stage DTL Over fluxing

In addition to the inverse curve, two independent DTL V/f elements are included and are used where the over excitation withstand curve of the transformer is not known. In this case the inverse V/f curve should be set to [Disabled] and both DTL elements should be set to [Enabled]. The default DTL settings are adequate to protect almost all transformer designs, and can be used with confidence.

Section 3: CT Requirements

The specification of CTs must meet the requirements of all protection functions utilised e.g. overall differential, REF and backup over current protections.

The relay has 1A and 5A rated terminals for each CT input and any combination of these may be used. 1A rated CTs can be used on one winding and together with 5A rated CTs on the other.

3.1 CT Requirement for Differential Protection

The quality of CTs will affect the performance of the protection system. The CT knee-point voltage (V_k) is a factor in assessing protection performance.

If a high level internal short circuit occurs the dc offset in the primary fault current may produce transient CT saturation. This is more likely to occur if the CT knee-point is low and/or the connected burden is high. Saturated CTs produce high levels of even harmonics which may increase the operate time of the biased differential function where harmonic restraint or inhibit is applied.

A highset differential element (87HS) can be used without harmonic restraint this can reduce the overall operating time of the differential protection.

Restricted Earth Fault protection helps ensure fast tripping as its speed of operation is not affected significantly by CT saturation.

For high speed operation:

$$V_k \geq 4 \times I_{FS} \times (R_{CT} + R_L)$$

Where:

V_k = CT knee point voltage.

I_{FS} = Max. secondary 3-phase through fault current (as limited by the transformer impedance).

R_{CT} = Secondary winding resistance of each star connected CT.

R_L = The CT secondary loop lead resistance.

Where the CTs used have a lower knee point voltage e.g. half that calculated in the expression above the biased differential elements may have a slightly longer operate time. To ensure stability during through fault conditions the biased differential settings should be increased by 10%.

Advice on CT Selection.

1A rated CT secondaries are preferred to 5A CTs as the CT VA burden is reduced by a factor of 25.

Line current transformer ratios should be selected to match the main transformer rating and ratio. However the **ICT Multiplier** adjustment can be used to compensate for non matched ratios. Choose a CT ratio that produces at least 0.33 x nominal secondary rating, when based on the transformer is at nameplate rating i.e. within the range of the **ICT Multiplier** setting.

Where long secondary lead lengths are required measures can be taken to reduce the burden imposed on the CTs:

Use high CT ratios to reduce the secondary current. Compensate the low secondary current using the ICT Multipliers..

Parallel CT secondary cable cores to reduce lead resistance.

Worked Example

90MVA, Z = 14%, Yd11, 132/33kV +10% to -20%

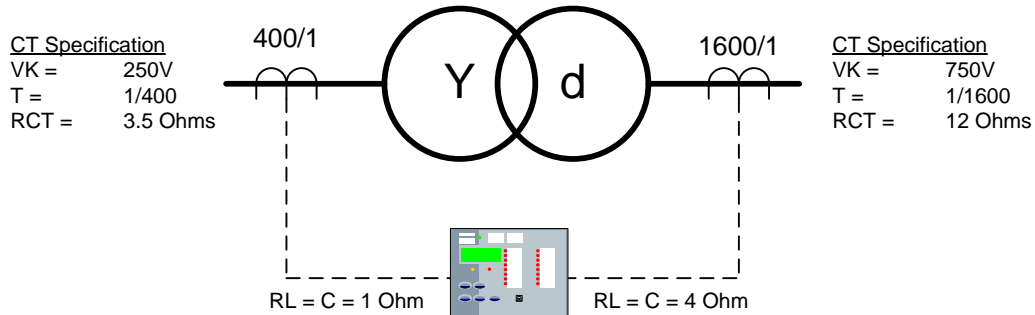

Figure 3-1 CT Requirements

Suitability of HV Current Transformers:

$$V_K \geq 4 \times \frac{90 \times 10^6}{\sqrt{3} \times 132 \times 10^3 \times 400 \times 0.14} \times (3.5 + 1) = 126.5V \text{ i.e. less than } 250V$$

Suitability of LV Current Transformers:

$$V_K \geq 4 \times \frac{90 \times 10^6}{\sqrt{3} \times 33 \times 10^3 \times 1600 \times 0.14} \times (12 + 4) = 449.9V \text{ i.e. less than } 750V$$

An indication of the suitability of a protection class CT e.g. class 5P to IEC60044 classification can be obtained. The product of its rated burden expressed in ohms and the secondary current equivalent of its accuracy limit primary current will give an approximation of the secondary voltage it can produce while operating within the limit of its stated composite error.

3.2 CT Requirements for High Impedance Restricted Earth Fault (64H)

For high impedance REF protection:

It is recommended that low reactance CTs conforming to IEC61869-2 Class PX are used. Class PX CTs have a specified excitation characteristic and secondary winding resistance and these parameters are used to calculate the performance of the protection in terms of primary operate current for internal faults and stability during through fault conditions.

All current transformers should have an equal turns ratio.

The knee-point voltage of the CTs must be greater than 2 x 64H Setting Voltage (Vs) – see section 2.4.

A full explanation of how to specify CTs for use with REF protection, and set REF relays is available on our Website: www.siemens.com/energy.

Section 4: Control Functions

4.1 User Defined Logic

4.1.1 Auto-Changeover Scheme Example

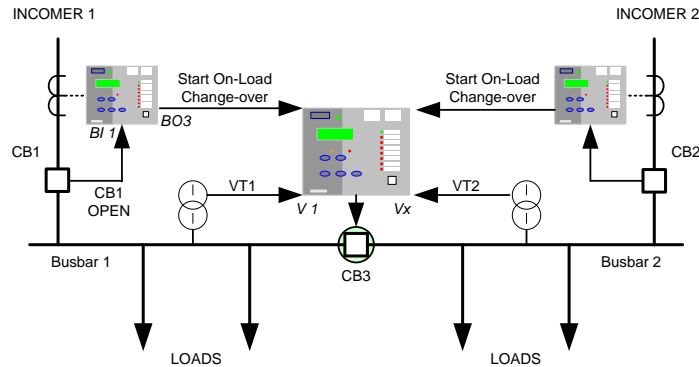

Figure 4-1 Example Use of Quick Logic

The MV installation illustrated above is fed from two incomers. To limit the substation fault level the busbar is run with CB3 open. When a fault occurs on one of the incomers it is isolated by the circuit protection. To re-supply the disconnected loads from the remaining incomer CB3 is closed.

If the line fault occurs on incomer 1 it must be confirmed that CB 1 has opened before CB3 can be closed. The relay on incomer 1 confirms that a trip has been issued to CB1 (e.g. Binary Output 2), that CB 1 has opened (e.g. Binary Input 1) and that no current flows in the circuit (e.g. 37-1 = Virtual 1):

Incomer 1 Relay is Configured:

CB1 Open auxiliary switch wired to B.I. 1

Trip output to CB1 = B.O. 2

OUTPUT CONFIG>OUTPUT MATRIX: **37-1 = V1**

OUTPUT CONFIG>OUTPUT MATRIX: **E1 = BO3**

CONTROL & LOGIC>QUICK LOGIC: **E1 = O2.I1.V1**

The output from Incomer 1 (BO3) relay is input to the relay on CB 3 (Binary Input 1). A panel switch may be used to enable the On-Load Change-over scheme (Binary Input 2). Before Closing CB3 a check may be made that there is no voltage on busbar 1 (27/59-1 = Virtual 1). CB 3 is closed from Binary Output 3.

CB3 Relay is Configured:

Panel switch (ON-Load Change-over Enabled) wired to B.I. 1

OUTPUT CONFIG>OUTPUT MATRIX: **27/59-1 = V1**

OUTPUT CONFIG>OUTPUT MATRIX: **E1 = BO3**

CONTROL & LOGIC>QUICK LOGIC: **E1 = I1.I2.V1**

If required a time delay can be added to the output using the CONTROL & LOGIC > QUICK LOGIC: **E1 Pickup Delay** setting.

Section 5: Supervision Functions

5.1 Inrush Detector (81HBL2)

87 Inrush Element (Enable, Disable)

When a transformer is energized transient magnetizing inrush currents flow in each phase of the energized winding. Inrush currents only flow into one transformer winding and the resulting unbalance can be sufficient to cause mal-operation of the biased differential elements. To prevent the relay operating for this non-fault condition, the presence of even harmonics in the current is used to distinguish between inrush currents and short circuit faults.

The inrush restraint detector can be used to block the operation of selected elements during transformer magnetising inrush conditions.

The **81HBL2 Bias** setting allows the user to select between, **Phase**, **Sum** and **Cross** methods of measurement. Each of the three selections has a specific application.

Phase – The even harmonic content in each phase is measured independently and compared to the total operate current in its own phase i.e. each phase of the biased differential elements is blocked by even harmonic content in its own phase only.

This method is used:

Where large transformers are manufactured with three separate phase tanks each containing a phase core. This construction facilitates transportation. Each of the phase cores is not magnetically affected by the flux in the other phase cores. These large single phase transformers are often auto-transformers used on EHV transmission systems. A typical setting level for this application is 18% of I_d .

Both ICT settings are selected to Yy e.g. reactor, motor, generator applications.

Cross – Each phase is monitored and if the even harmonic present in any phase exceeds the setting then all three phases are blocked. This method is used for the majority of applications of the relay to power transformers.

Generally the default setting of $0.20 \times I_d$ provides stable operation.

Sum – The level of even harmonic current (2nd and 4th) in the differential signal for each phase is measured. The square root is taken of each of these even harmonic currents and these three values summated. This single current level is then divided by the Inrush Setting to arrive at the Harmonic Sum with which each of the phase currents are compared.

If the operate current in any phase is greater than this Harmonic Sum then its differential element will operate.

The advantage of this method is it allows fast operation of the biased differential element if the transformer is switched onto an internal phase to earth fault. The cross method may suffer from slowed operation for this situation, as healthy phase inrush may block all three phases (including the one feeding the fault current) from operating. Where REF is used to protect the winding, the slowed operation is not critical as the REF will operate very fast, typically in about 20ms for this rare condition.

The Sum method is not slowed down when switching onto an in zone earth fault, as the Harmonic Sum is reduced by the presence of the fault current and therefore allows relay operation.

Typically the Sum method will allow the biased differential elements to operate in the normal time of about 30ms, if a transformer earth fault occurs when it is energised.

This setting is recommended if REF is not used to protect the windings for earth faults on effectively earthed power systems. The recommended setting that offers a good compromise between stability for typical inrush currents and fast operation for internal faults is $0.15 \times I_d$.

87 Inrush Setting (0.1 to 0.5 x Id)

This defines the levels of inrush used in each of the above methods.

The setting applied will determine the level of even harmonic (second and fourth) content in the relay operating current that will cause operation of the relay to be inhibited. The lowest setting of 0.1 x Id therefore represents the setting that provides the most stability under magnetising inrush conditions.

The recommended settings for each method are:

Phase – 0.18 x Id

Cross – 0.20 x Id

Sum – 0.15 x Id

These settings provide a good compromise between speed of operation for internal faults and stability for inrush current. Generally the above values will be stable for most cases, but in rare cases may not prevent relay operation for all angles of point on wave switching, and the setting may require being lower slightly. If the relay operates when the transformer is energised, the waveform record should be examined for signs of fault current and the levels of harmonic current.

Set to 0.20 x Id unless a very rare false operation for inrush occurs. In which case a lower setting should be adopted after checking the waveform record for the presence of fault current.

5.2 Overfluxing Detector (81HBL5)

An increase in transformer or decrease in system frequency may result in the transformer becoming over-excited. The 81HBL5 element can be used to prevent protection operation e.g. prevent differential protection operation during acceptable over-excitation conditions.

5.3 Circuit Breaker Fail (50BF)

Where a circuit breaker fails to operate to clear fault current the power system will remain in a hazardous state until the fault is cleared by remote or back-up protections. To minimise any delay, CB Failure protection provides a signal to either re-trip the local CB or back-trip the next 'upstream' CB.

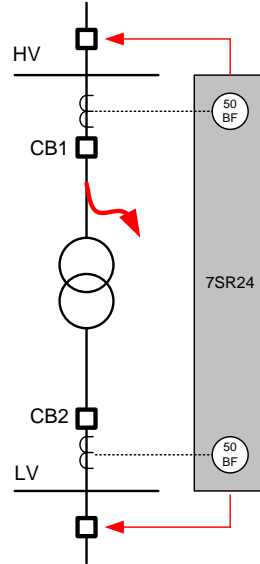

Figure 5-1 - Circuit Breaker Fail

The CBF function is initiated by the operation of either:

Protection functions that operate binary outputs mapped as **OUTPUT CONFIG>BINARY OUTPUT CONFIG>CBn Trip Contacts**, or

A binary input mapped as **INPUT CONFIG>INPUT MATRIX >C50BF-n Ext Trip**

Each 50BF uses phase segregated current check elements and two timers.

Current in each phase is monitored and if any of the 50BF current check elements have not reset before the timers have expired an output is given. Typically a single stage scheme is used, DTL1 is wired to back-trip the adjacent CBs e.g. via the busbar protection system. Alternatively the first timer output can be wired to re-trip the failed CB through a different trip coil, and the second timer output is wired to trip the adjacent CBs.

Practical time sequences for single and two stage 50BF applications are illustrated below.

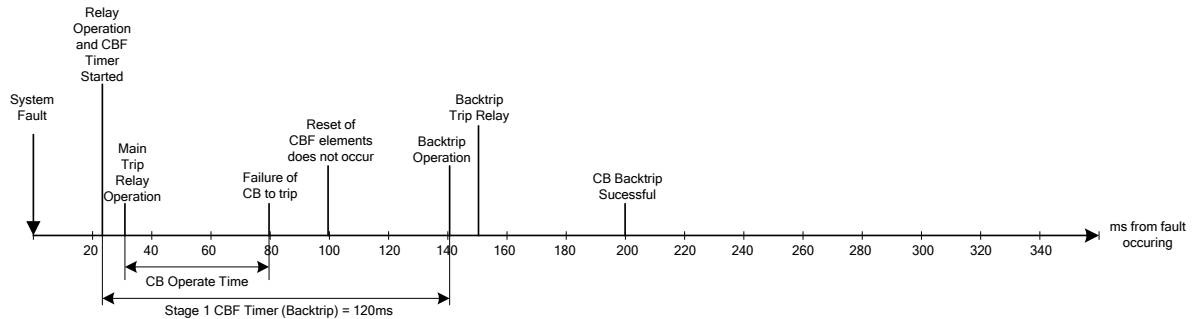

Figure 5-2 - Single Stage Circuit Breaker Fail Timing

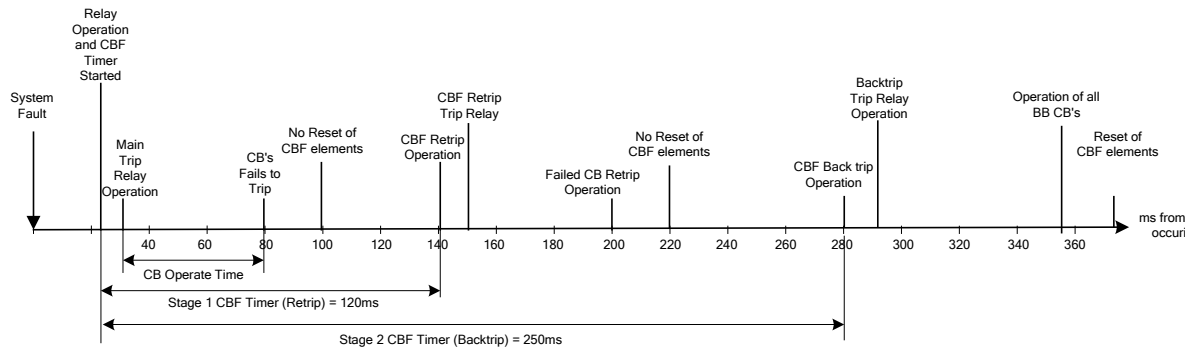

Figure 5-3 - Two Stage Circuit Breaker Fail Timing

Example of Required Settings (e.g. HV CB)

FUNCTION CONFIG>

Gn CB Fail Enabled

SUPERVISION > CB FAIL > 50BF-1

Gn 50BF-1 Element Enabled
Gn 50BF-1 Setting 0.2 x In
Gn 50BF-1-1 Delay 120ms
Gn 50BF-1-2 Delay 250ms

INPUT CONFIG>INPUT MATRIX>

50BF-1 Ext Trip BIn

OUTPUT CONFIG>OUTPUT MATRIX>

50BF-1-1 BOn, Ln
50BF-1-2 BOn, Ln

OUTPUT CONFIG>BINARY OUTPUT CONFIG>

CB1 Trip Contacts BOn

The above based on:

<i>First Stage Backtrip (or Re-trip)</i>	<i>Typical Times</i>
<i>Trip Relay operate time</i>	<i>10ms</i>
<i>CB Tripping time</i>	<i>50ms</i>
<i>DUOBias-M Reset Time</i>	<i>30ms</i>
<i>Safety Margin</i>	<i>30ms</i>
<i>Overall First Stage CBF Time Delay</i>	<i>120ms</i>

Second Stage (Back Trip)

<i>First CBF Time Delay</i>	<i>120ms</i>
<i>Trip Relay operate time</i>	<i>10ms</i>
<i>DUOBias-M Reset Time</i>	<i>30ms</i>
<i>CB Tripping time</i>	<i>50ms</i>
<i>Margin</i>	<i>50ms</i>
<i>Overall Second Stage CBF Time Delay</i>	<i>260ms</i>

5.4 Trip Circuit Supervision (74TCS)

Binary Inputs may be used to monitor the integrity of the CB trip circuit wiring. Current flows through the B.I. confirming the integrity of the auxiliary supply, CB trip coil, auxiliary switch, C.B. secondary isolating contacts and associated wiring connected to that BI. If the current flow ceases, the B.I. drops off and if it is user programmed to operate one of the output relays, this can be used to provide an alarm. In addition, an LED on the relay fascia can be programmed to operate. A user text label can be used to define the operated LED e.g. "Trip CCT Fail".

The relevant Binary Input is mapped to 74TCS-n in the INPUT CONFIG>INPUT MATRIX menu. To avoid giving spurious alarm messages while the circuit breaker is operating the input is given a 0.4s Drop-off Delay in the INPUT CONFIG>BINARY INPUT CONFIG menu.

To provide an alarm output a normally open binary output is mapped to 74TCS-n.

5.4.1 Trip Circuit Supervision Connections

The following circuits are derived from UK ENA S15 standard schemes H5, H6 and H7.

For compliance with this standard:

Where more than one device is used to trip the CB then connections should be looped between the tripping contacts. To ensure that all wiring is monitored the binary input must be at the end of the looped wiring.

Resistors must be continuously rated and where possible should be of wire-wound construction.

Scheme 1 (Basic)

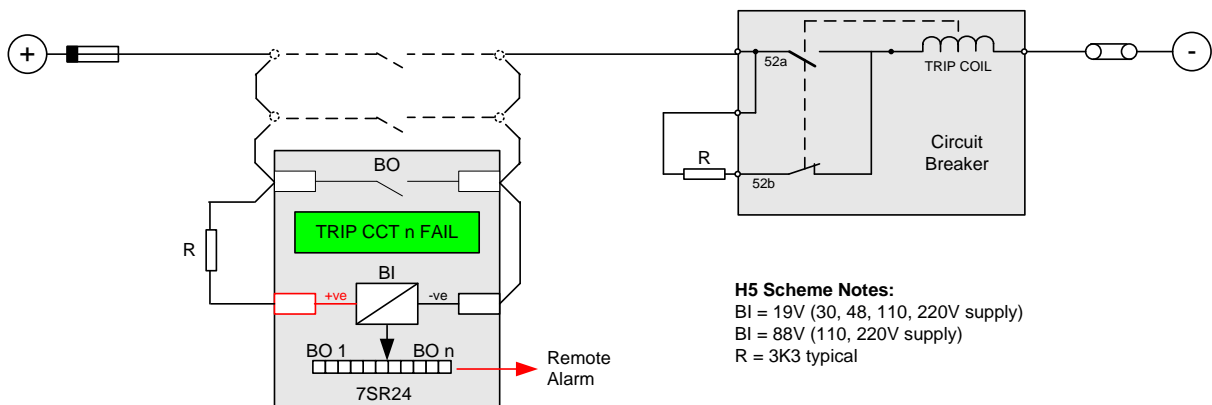

Figure 5-4: Trip Circuit Supervision Scheme 1 (H5)

Scheme 1 provides full Trip and Close supervision with the circuit breaker Open or Closed.

Where a 'Hand Reset' Trip contact is used measures must be taken to inhibit alarm indications after a CB trip.

Scheme 2 (Intermediate)

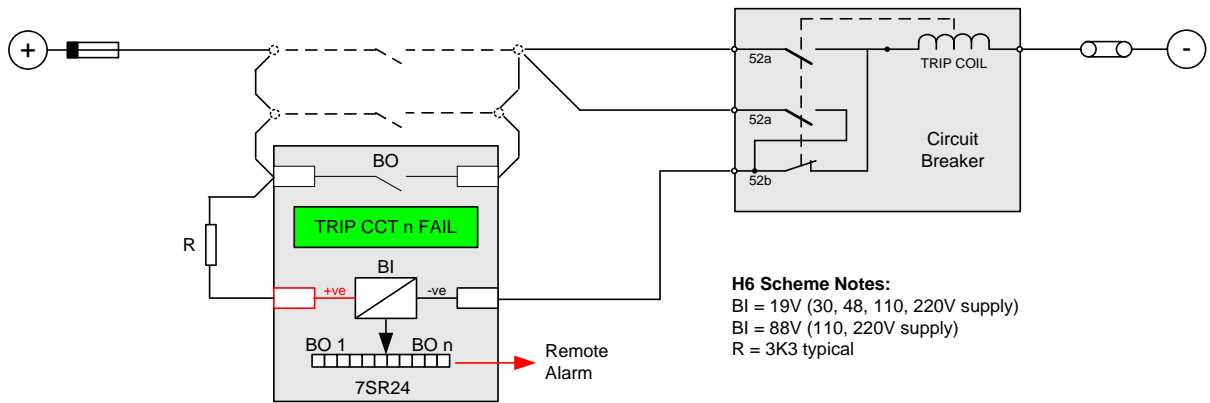

Figure 5-5: Trip Circuit Supervision Scheme 2 (H6)

Scheme 2 provides continuous Trip Circuit Supervision of trip coil with the circuit breaker Open or Closed. It does not provide pre-closing supervision of the connections and links between the tripping contacts and the circuit breaker and may not therefore be suitable for some circuits which include an isolating link.

Scheme 3 (Comprehensive) – 19V Binary Input Only

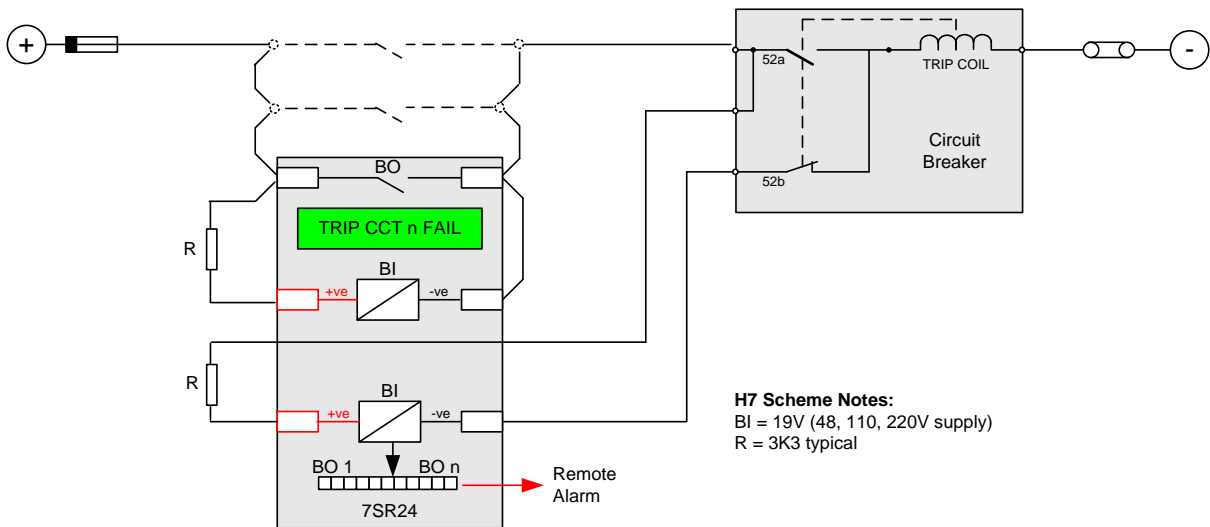

Figure 5-6: Trip Circuit Supervision Scheme 3 (H7)

Scheme 3 provides full Trip and Close supervision with the circuit breaker Open or Closed.

5.4.2 Close Circuit Supervision Connections

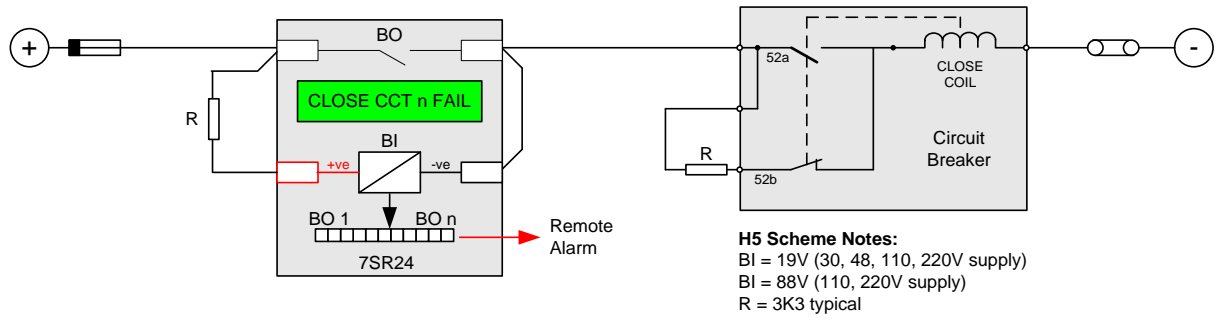

Figure 5-7 Close Circuit Supervision Scheme

Close circuit supervision with the circuit breaker Open or Closed.

Section 6: Application Considerations and Examples

6.1 The Effects of An In Zone Earthing Transformer

The in zone earthing transformer is a source of zero-sequence fault current. An earth fault on the delta side of the transformer external to the differential protection zone will cause zero sequence currents to flow in the CTs on the delta side of the transformer without corresponding current to flow in the line CTs on the star side of the transformer. If these zero sequence currents are allowed to flow through the differential elements they may cause undesired tripping.

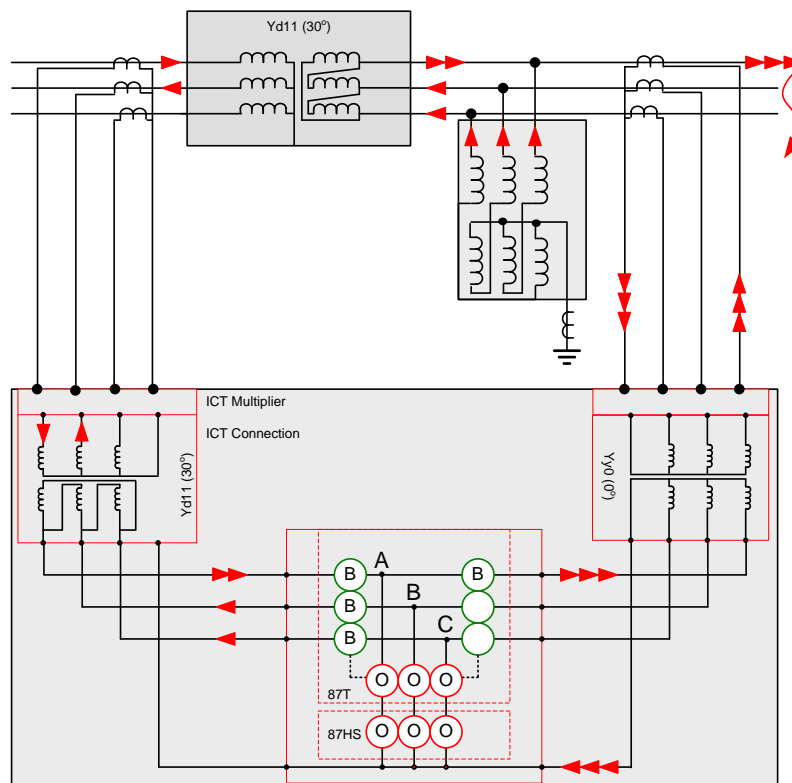

Figure 6-1: Relay Currents – External Earth Fault with In Zone Earthing Transformer

To prevent undesired tripping the ICT connections should be such as to cause the zero sequence currents to flow in a closed delta CT secondary connection of low impedance instead of in the differential relay operating coil. As we have already corrected for the transformer vector group on the star side a Ydy0 ICT is used on the delta side winding.

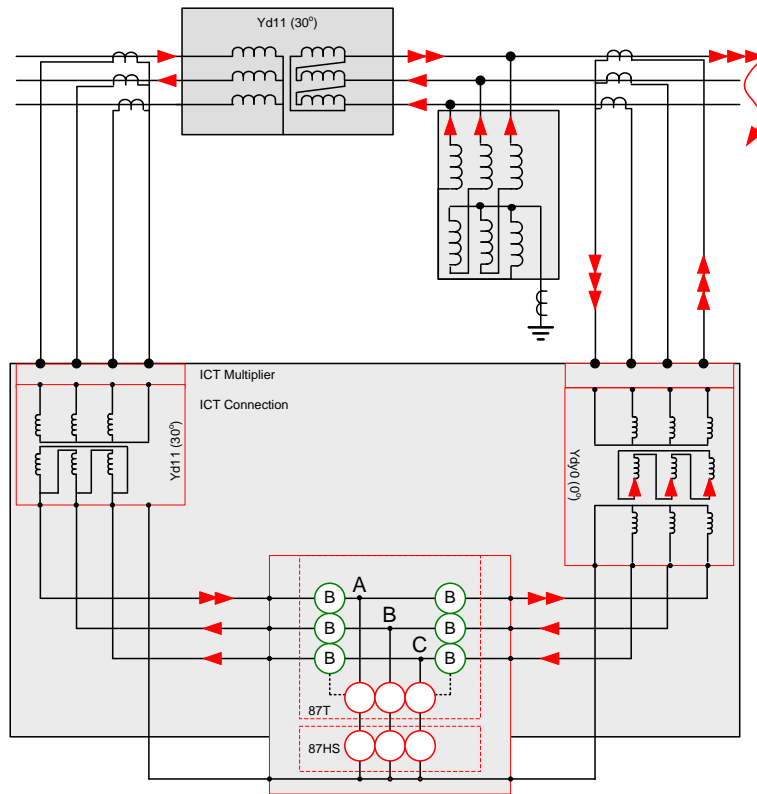

Figure 6-2: Relay Currents – External Earth Fault with In Zone Earthing Transformer

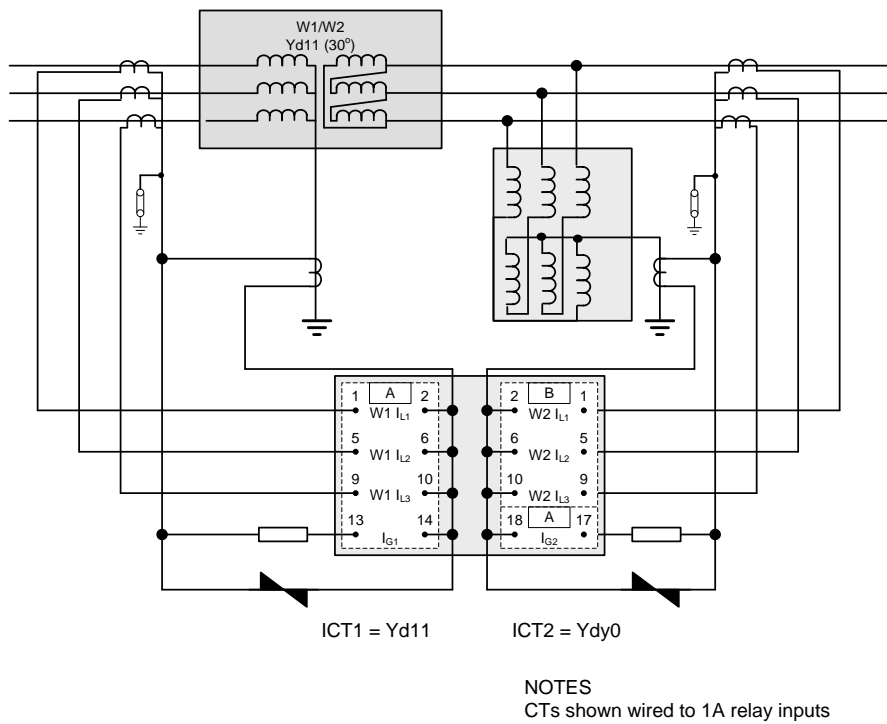

Figure 6-3 7SR24 Applied to Yd Transformer with an In Zone Earthing Transformer

6.2 Protection of Star/Star Transformer With Tertiary Winding

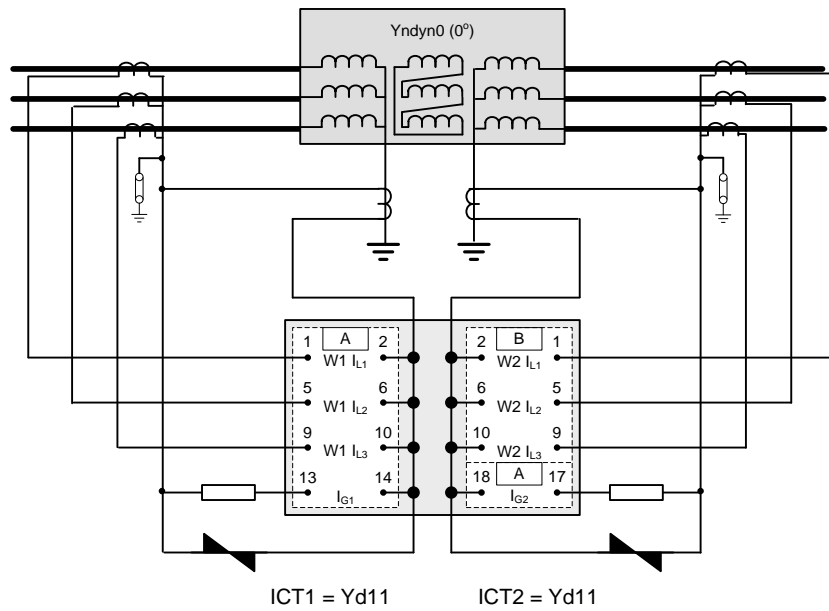

Figure 6-4: Protection of Star/Star Transformer with Tertiary

The provision of the tertiary winding in star/star transformers both stabilises the neutral potential and can allow earth fault current to flow in the secondary connections i.e. reduces the zero sequence impedance. An earth fault on the LV side of the transformer external to the differential protection zone will cause zero sequence currents to flow in the CTs on the LV side without corresponding current to flow in the line CTs on the HV side. If these zero sequence currents are allowed to flow through the differential elements they may cause undesired tripping. The transformer has a phase shift of zero. To prevent undesired tripping for external faults a zero sequence shunt is required, this is implemented by selecting star/delta interposing CT settings. The Interposing CT Connection setting on all sets of current inputs must be set to the same Yd setting e.g. all Yd1, -30° or all Yd11, 30°.

6.3 Transformer with Primary Connections Crossed on Both Windings

Yd11 Transformer Connected as Yd9 (90°)

The phase-shift between the W1 and W2 primary systems may necessitate that primary connections to each winding of the transformer have to be crossed. Fig. 6.4-1 shows a typical arrangement where a Yd11 transformer is arranged to give a primary system phase-shift of 90° by crossing of its main connections. There are two optional methods of configuring the 7SR24 relay.

Solution 1

Figure 6-5 shows W1 and W2 CT secondary wiring crossed over to replicating the crossovers on the transformer primary connections:

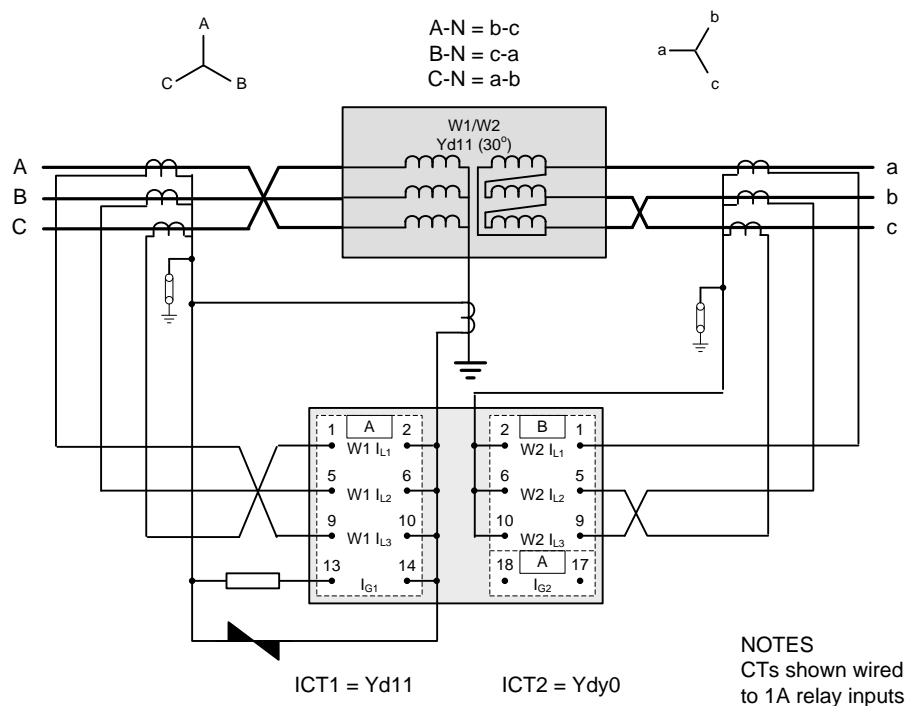

Figure 6-5 – AC Connections: Yd9, 90° Transformer – Non-standard Secondary Connections

Notes:

An advantage of the above is that the 7SR24 relay can be set to correspond to the vector group shown on the main transformer rating plate i.e. Yd11, +30° simplifying installation. This approach is also applicable where the transformer is used to reverse the system phase sequence – see section 6.5.

A disadvantage is that 'non-standard' secondary wiring connections are used.

Relay instruments will indicate 'transformer' quantities rather than system quantities.

Solution 2

Fig. 6-6 shows use of the ICT Connection settings to correct for the phase shift introduced by the transformer connection i.e. **ICT1 Connection** is set to Yd9, -90° and **ICT2 Connection** is set to Ydy0, 0°.

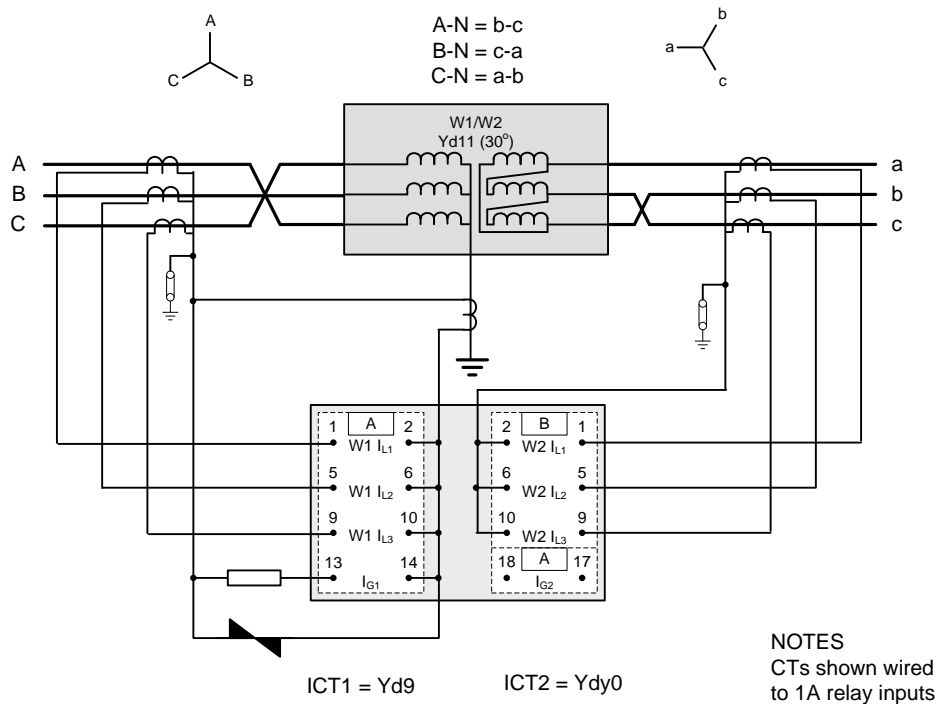

Fig. 6-6 AC Connections: Yd9, 90° Transformer – Standard Secondary Connections

Notes:

An advantage of the approach above is that 'standard' secondary wiring connections are used.

The 7SR24 relay setting correspond to the power system vector relationship i.e. Yd9, 90°.

Relay instruments will indicate 'system' quantities rather than transformer quantities.

6.4 Transformer with Primary Connections Crossed on One Winding

Reversing the connections on only one side of the transformer will reverse the phase sequence of the system. For this arrangement W1 and W2 CT secondary wiring must be crossed over to replicate the crossovers on the transformer primary connections – see Fig. 6-7.

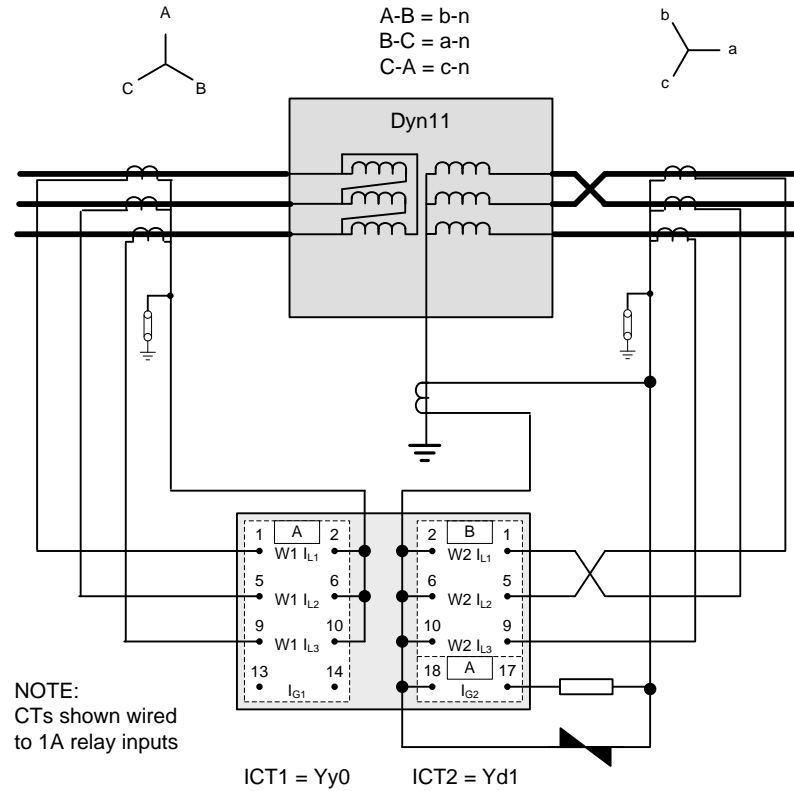

Fig. 6-7 Dyn11 Transformer with Reverse Phase Notation

Notes:

The 7SR24 relay is set to correspond to the vector group shown on the main transformer rating plate i.e. Dy11, +30°.

Relay instruments will indicate 'transformer' quantities rather than system quantities.

6.5 Protection of Auto Transformers

The transformer has a phase shift of zero. To prevent undesired tripping of the overall differential protection for external faults a zero sequence shunt is required, this is implemented by selecting **ICT Connection** setting on both sets of CT inputs to Ydy0. The inrush inhibit (81HBL2) must be Enabled as the magnetising inrush currents in each phase will not balance.

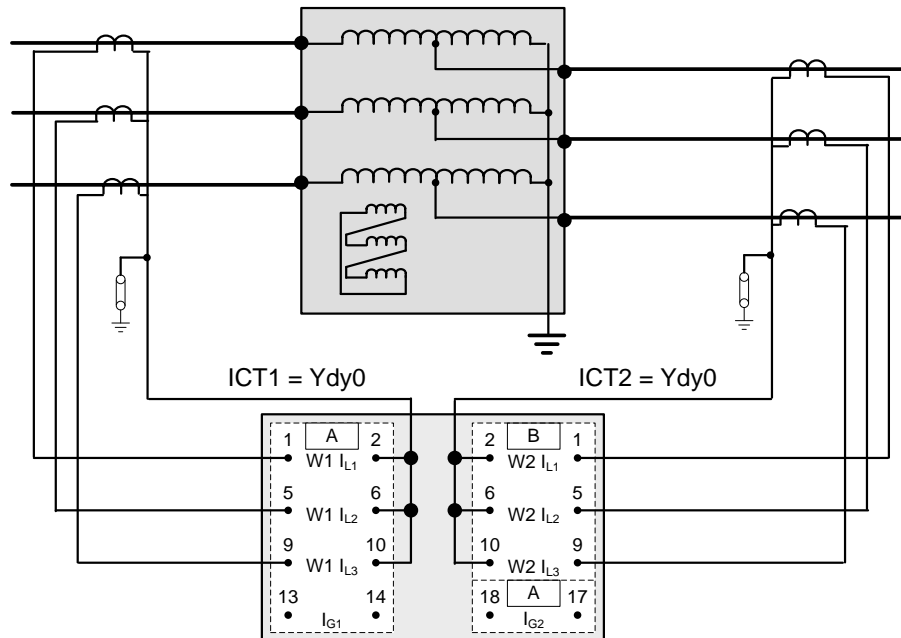

Fig. 6-8: AC Connections for Auto-Transformer Overall Protection

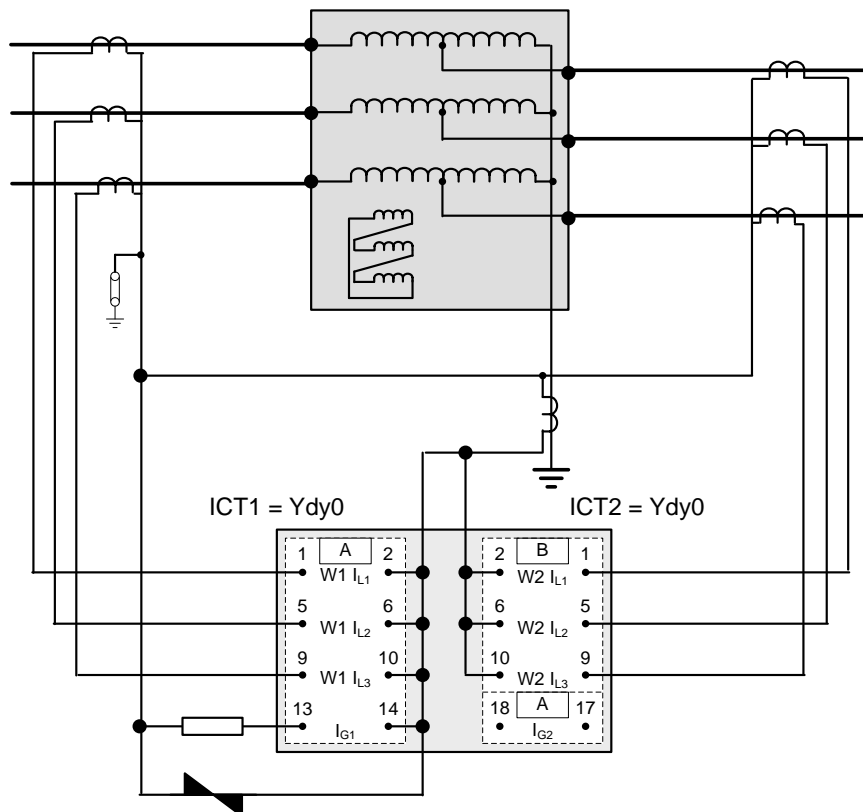

Fig. 6-9: AC Connections for Auto-Transformer Overall and REF Protection

6.6 Reactor, Motor and Connections Protection

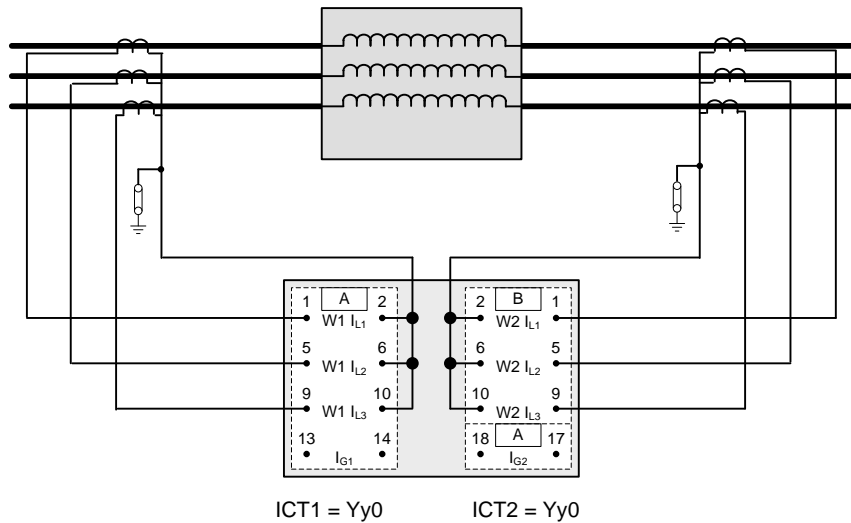

Fig. 6-10 AC Connections for Reactor and Connections Protection

Settings must take into consideration:

Connections: High internal and through fault currents.

Series reactor: Through fault current limited by reactor.

Shunt reactor: Single end fed faults only.

Motor: Single end fed faults only.

Generator: Single end fed faults only.

Primary current values are not subject to variation due to tap changing (as in transformer / OLTC applications), the 87BD and 87BD 1st Bias Slope can both be set to 0.1.

The inrush inhibit feature (81HBL2) must be enabled as the magnetising inrush currents in each phase will not balance.

Section 7: Common Functions

7.1 Multiple Settings Groups

Alternate settings groups can be used to reconfigure the relay during significant changes to system conditions e.g.

- Primary plant switching in/out.
- Summer/winter or day/night settings.
- Switchable earthing connections.
- Allowable short term overloads.
- Loss of Grid connection (see below)

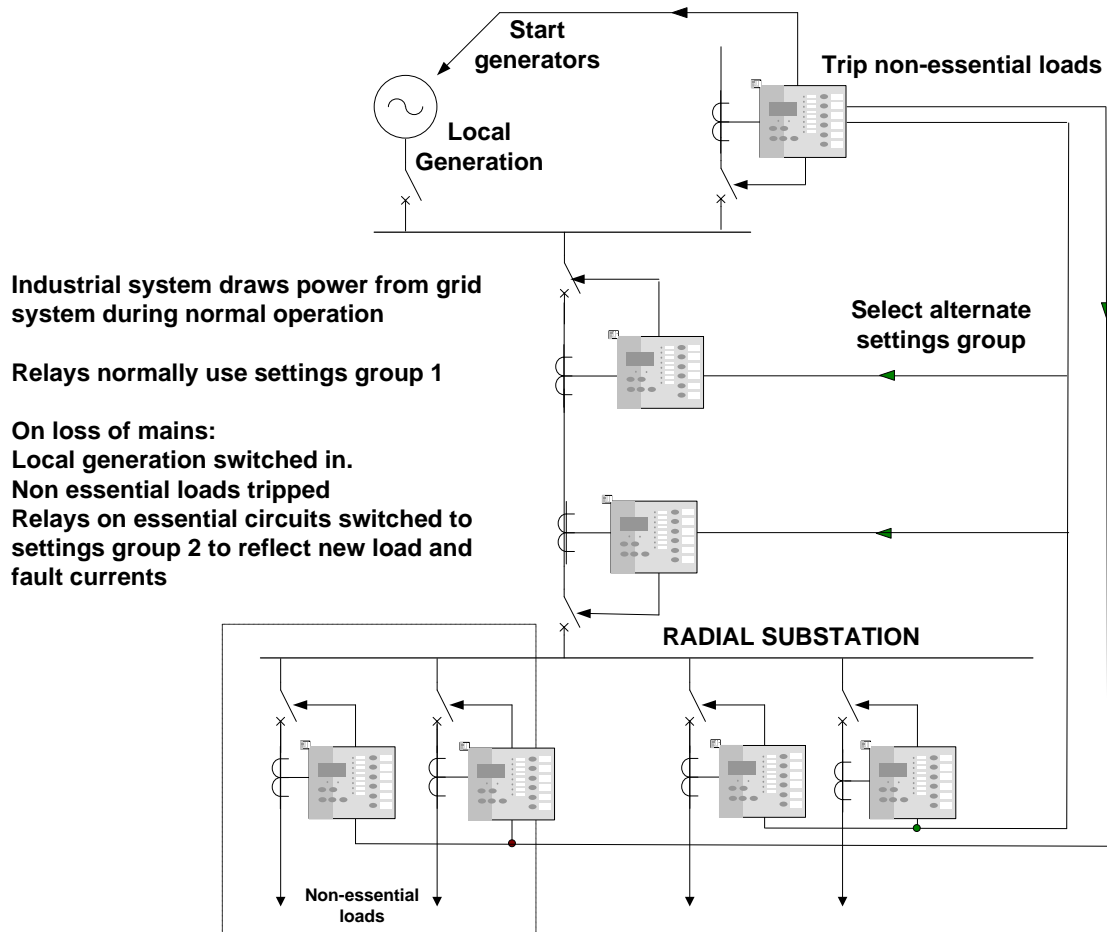

Figure 7-1 Example Use of Alternative Settings Groups

7.2 Binary Inputs

Each Binary Input (BI) can be programmed to operate one or more of the relay functions, LEDs or output relays. These could be used to bring such digital signals as Inhibits for protection elements, the trip circuit supervision status, autoreclose control signals etc. into the Relay.

Alarm and Tripping Inputs

A common use of binary inputs is to provide indication of alarm or fault conditions e.g. transformer Buchholz Gas or Buchholz Surge conditions. The Binary Inputs can be mapped to LED(s), waveform storage trigger and binary outputs.

The inputs can also be mapped as 'General Alarms' – this allows user defined text to be displayed on the LCD when the BI is energised. Inputs used in this way are programmed using:

INPUT CONFIG>INPUT MATRIX>**General Alarm n** – Assigned to BI.

INPUT CONFIG>GENERAL ALARMS>**General Alarm n** – 16 character string.

Where transformer outputs require high speed tripping, such as a Buchholz Surge, these should be wired to a binary input to provide LED indication and also have a parallel connection wired to directly trip the circuit via a blocking diode, see Figure 7-2:

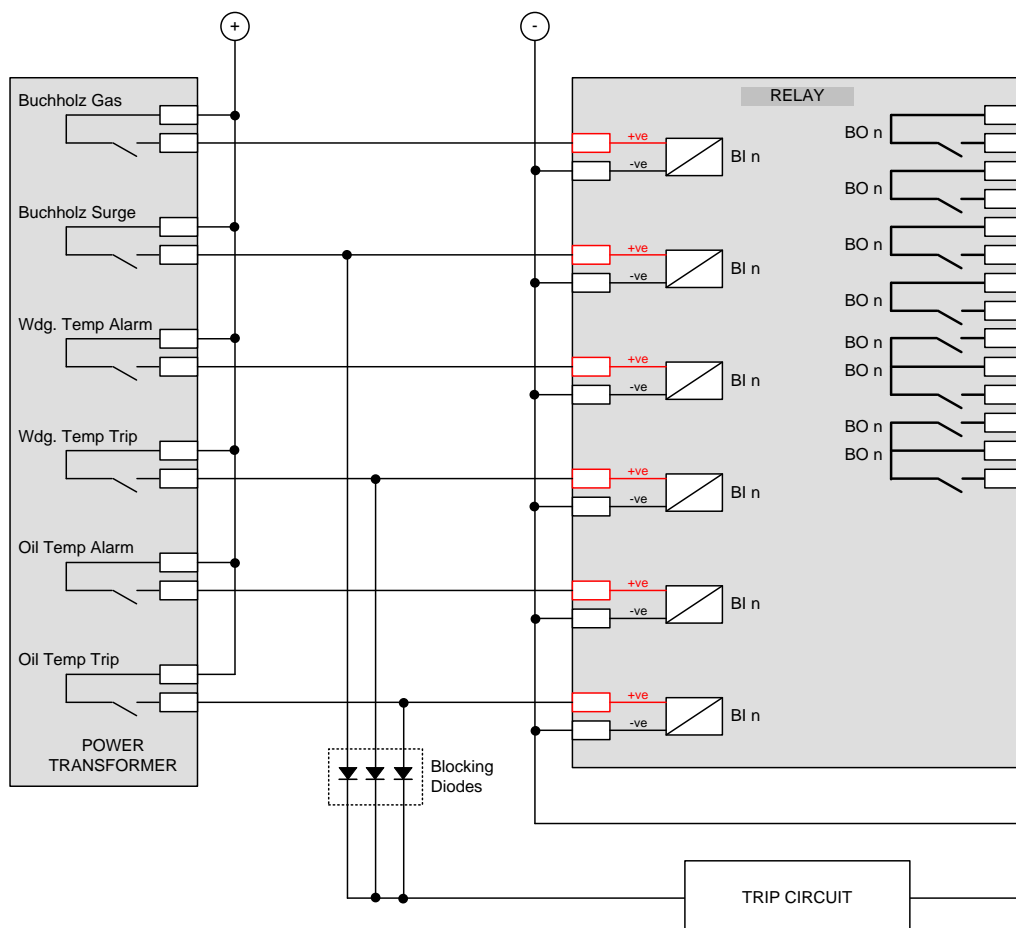

Figure 7-2 Example of Transformer Alarm and Trip Wiring

The Effects of Capacitance Current

The binary inputs have a low minimum operate current and may be set for instantaneous operation. Consideration should be given to the likelihood of mal-operation due to capacitance current. Capacitance current can flow through the BI, for example if an earth fault occurs on the dc circuits associated with the relay. The binary inputs will be less likely to mal-operate if they:

- 1 Have both the positive and negative switched (double-pole switched).
- 2 Do not have extensive external wiring associated with them e.g. if the wiring is confined to the relay room.

Where a binary input is both used to influence a control function (e.g. provide a tripping function) and it is considered to be susceptible to mal-operation the external circuitry can be modified to provide immunity to such disturbances, see Figure 7-3.

AC Rejection

The default pick-up time delay of 20ms provides immunity to ac current e.g. induced from cross site wiring.

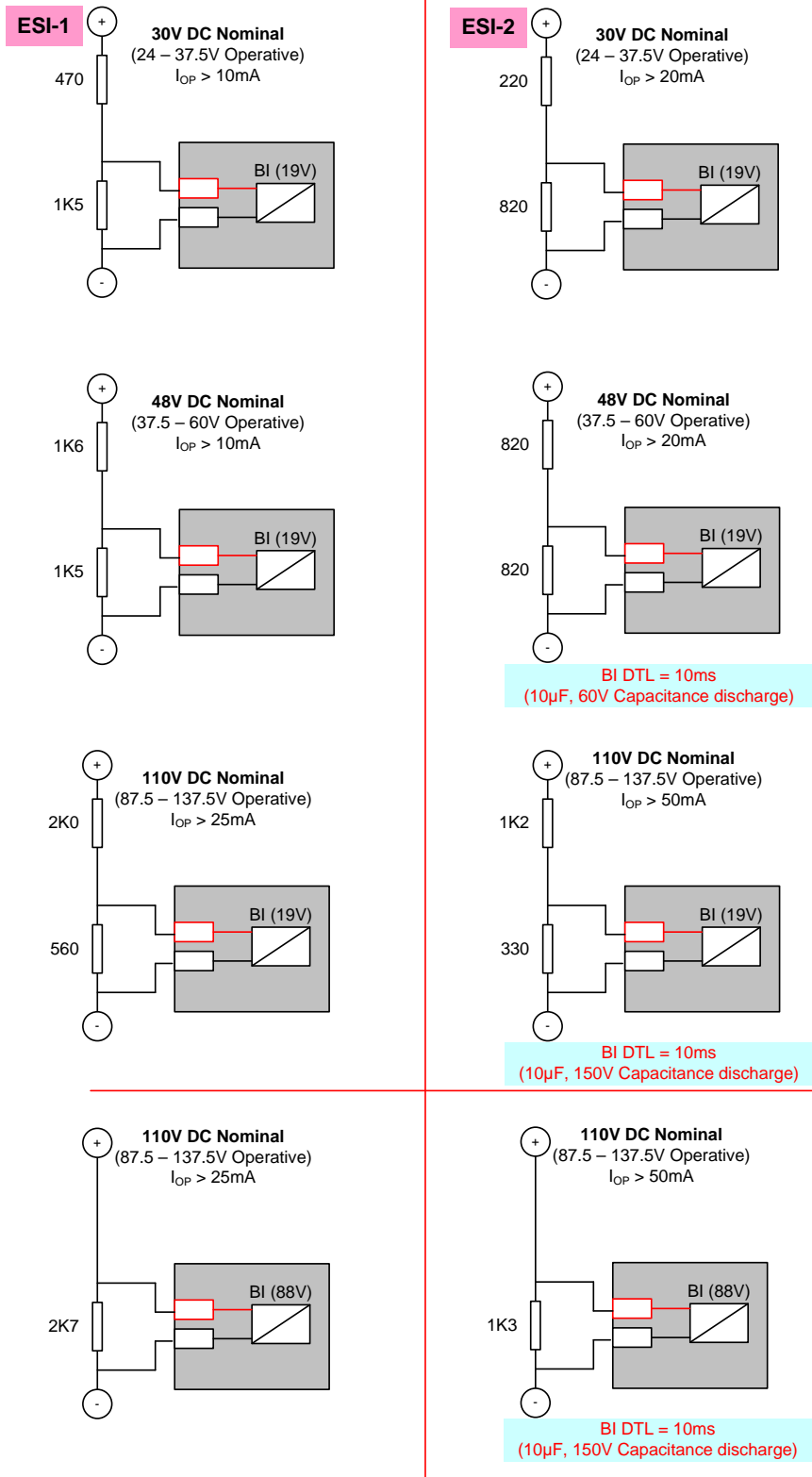

Resistor power ratings: 30V DC Nominal >3W
 48V DC Nominal >3W
 110V DC Nominal >10W (ESI- 1)
 110V DC Nominal >20W (ESI-2)

Resistors must be wired with crimped connections as they may run hot

Figure 7-3 – Binary Input Configurations Providing Compliance with EATS 48-4 Classes ESI 1 and ESI 2

7.3 Binary Outputs

Binary Outputs are mapped to output functions by means of settings. These could be used to bring out such digital signals as trips, a general pick-up, plant control signals etc.

All Binary Outputs are trip rated

Each can be defined as Self or Hand Reset. Self-reset contacts are applicable to most protection applications. Hand-reset contacts are used where the output must remain active until the user expressly clears it e.g. in a control scheme where the output must remain active until some external feature has correctly processed it.

Case contacts C25 and C26 will automatically short-circuit when the relay is withdrawn from the case. This can be used to provide an alarm that the Relay is out of service.

Notes on Self Reset Outputs

With a failed breaker condition the relay may remain operated until current flow in the primary system is interrupted by an upstream device. The relay will then reset and attempt to interrupt trip coil current flowing through an output contact. Where this level is above the break rating of the output contact an auxiliary relay with heavy-duty contacts should be utilised.

7.4 LEDs

Output-function LEDs are mapped to output functions by means of settings. These could be used to display such digital signals as trips, a general pick-up, plant control signals etc.

User Defined Function LEDs are used to indicate the status of Function Key operation. These do not relate directly to the operation of the Function Key but rather to its consequences. So that if a Function Key is depressed to close a Circuit-Breaker, the associated LED would show the status of the Circuit-Breaker closed Binary Input.

Each LED can be defined as Self or Hand Reset. Hand reset LEDs are used where the user is required to expressly acknowledge the change in status e.g. critical operations such as trips or system failures. Self-reset LEDs are used to display features which routinely change state, such as Circuit-Breaker open or close.

The status of hand reset LEDs is retained in capacitor-backed memory in the event of supply loss.

Siemens Protection Devices Limited

P.O. Box 8, North Farm Road

Hebburn, Tyne & Wear

NE31 1TZ

United Kingdom

Phone: +44 (0)191 401 7901

Fax: +44 (0)191 401 5575

E-mail: marketing.spdl.gb@siemens.com

For enquires please contact our Customer Support Center

Phone: +49 180/524 8437 (24hrs)

Fax: +49 180/524 2471

E-mail: support.energy@siemens.com

EMEA-T10045-00-76GB

August 19