

Product datasheet

Specifications



servo motor BCH, Lexium 28,
180mm, 2000W, 35.13kg.cm², with
oil seal, without key, brake, straight
connection

BCH2HR2022CF6C

Main

Range compatibility	Lexium 28
Device short name	BCH2
Product or component type	Servo motor

Complementary

Maximum mechanical speed	3000 rpm
[Us] rated supply voltage	220 V
Network number of phases	Three phase
Continuous stall current	8.75 A
Continuous stall torque	9.55 N.m for LXM28 at 9.6 mA, 220 V, single phase 9.55 N.m for LXM28 at 9.6 mA, 220 V, three phase
Continuous power	2000 W
Peak stall torque	28.6 N.m for LXM28... at 9.6 mA, 220 V, single phase 28.6 N.m for LXM28... at 9.6 mA, 220 V, three phase
Nominal output power	2000 W for LXM28... at 9.6 mA, 220 V, single phase 2000 W for LXM28... at 9.6 mA, 220 V, three phase
Nominal torque	9.55 N.m for LXM28... at 9.6 mA, 220 V, single phase 9.55 N.m for LXM28... at 9.6 mA, 220 V, three phase
Nominal speed	2000 rpm for LXM28... at 9.6 mA, 220 V, single phase 2000 rpm for LXM28... at 9.6 mA, 220 V, three phase
Maximum current Irms	35.5 A for LXM28... at 2 kW, 220 V
Maximum permanent current	9.6 A
Product compatibility	LXM28... servo drive motor at 2 kW, 220 V, single phase LXM28... servo drive motor at 2 kW, 220 V, three phase
Shaft end	Smooth shaft
Shaft diameter	35 mm
Shaft length	79 mm
Feedback type	20 bits single turn absolute encoder
Holding brake	With
Holding torque	48 N.m built-in
Mounting support	Asian standard flange
Motor flange size	180 mm
Electrical connection	Connector MIL
Torque constant	1.09 N.m/A at 20 °C

Excluding VAT and subject to change. Please check with your local distributor through "Where to buy"

Back emf constant	66 V/krpm at 20 °C
Number of motor poles	5.0
Rotor inertia	35.13 kg.cm ²
Stator resistance	0.34 Ohm at 20 °C
Stator inductance	6.1 mH at 20 °C
Stator electrical time constant	13.24 ms at 20 °C
Maximum radial force Fr	670 N at 2000 rpm
Maximum axial force Fa	200 N
Brake pull-in power	49.6 W
Type of cooling	Natural convection
Length	203 mm
Number of motor stacks	4
Centring collar diameter	110 mm
Centring collar depth	8 mm
Number of mounting holes	4
Mounting holes diameter	9.2 mm
Circle diameter of the mounting holes	145 mm
Distance shaft shoulder-flange	8 mm
Net weight	19.3 kg
Sizing reference	BCH2
Network number of phases	3
Accuracy error [angular]	0.044 °
Temperature copper hot	135 °C
Temperature magnet hot	100 °C
Temperature magnet rt	20 °C
Inertia	35.12 kg.cm ² of brake 35.13 kg.cm ² of motor

Environment

IP degree of protection	IP50 IM V3 IP65 IM B5, IM V1
Ambient air temperature for operation	0...40 °C

Packing Units

Unit Type of Package 1	PCE
Number of Units in Package 1	1
Package 1 Height	24.5 cm
Package 1 Width	18 cm
Package 1 Length	20.3 cm
Package 1 Weight	18 kg

Contractual warranty



Environmental Data

Schneider Electric aims to achieve Net Zero status by 2050 through supply chain partnerships, lower impact materials, and circularity via our ongoing “Use Better, Use Longer, Use Again” campaign to extend product lifetimes and recyclability.

[Environmental Data explained >](#)

[How we assess product sustainability >](#)



Environmental footprint

Total lifecycle Carbon footprint	2 274 kg CO2 eq.
Carbon footprint of the manufacturing phase [A1 to A3]	111 kg CO2 eq.
Carbon footprint of the distribution phase [A4]	2 kg CO2 eq.
Carbon footprint of the installation phase [A5]	0.1 kg CO2 eq.
Carbon footprint of the use phase [B2, B3, B4, B6]	2 159 kg CO2 eq.
Carbon footprint of the end-of-life phase [C1 to C4]	2 kg CO2 eq.

Use Better



Materials and Substances

Packaging made with recycled cardboard	No
Packaging without single use plastic	No
EU RoHS Directive	Under investigation
REACH Regulation	REACH Declaration

Use Longer



Lifetime extension

Repair	No
--------	----

Use Again



Repack and remanufacture

Take-back	No
-----------	----

Dimensions Drawings

Dimensions

Dimensions of Motor

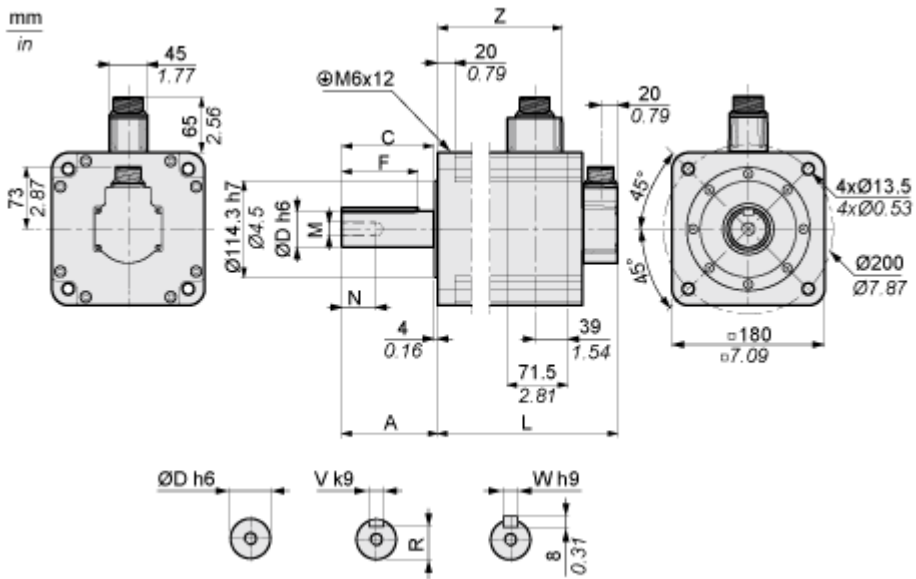

	mm	in.
L (without holding brake)	169	6.65
L (with holding brake)	203	7.99
A	79	3.11
C	73	2.87
D	35	1.38
F	63	2.48
N	28	1.10
M	M12	
R	30	1.18
V	10	0.39
W	10	0.39
Z	103	4.06

Performance Curves

Torque/Speed Curves with 230 V Three Phase Supply Voltage

Servo Motor with LXM28AU20••• Servo Drive

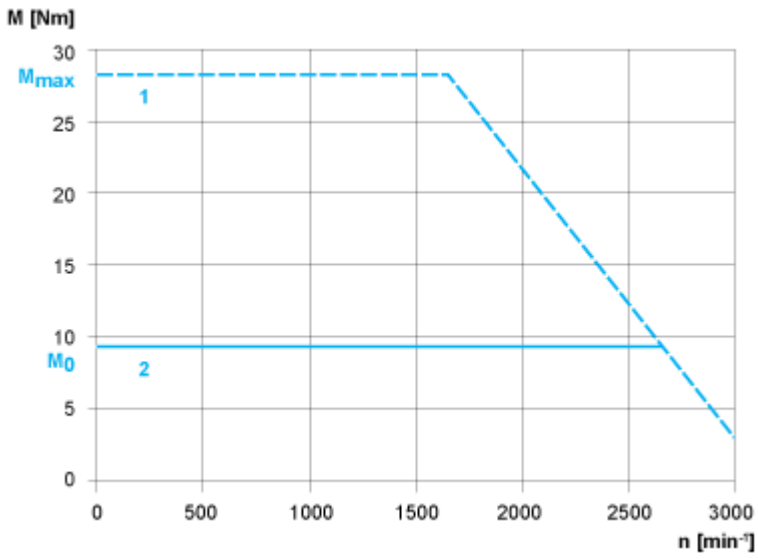

- 1 : Peak torque
- 2 : Continuous torque