

Mitsubishi PLC

MELSEC Q series MELSOFT



QJ71C24N, QJ71C24N-R2, QJ71C24N-R4

Serial Communication Modules GX Configurator-SC Version2

Introducing New 2-channel RS-422/485 Serial Communication Modules for Q Series

● GX Configurator-SC Version 2 makes the modules easier to use.

New Q series serial communication modules

Transmission speed of up to 230,400 bps is available!

Supporting circuit trace and communication test for GX Configurator-SC Version 2!

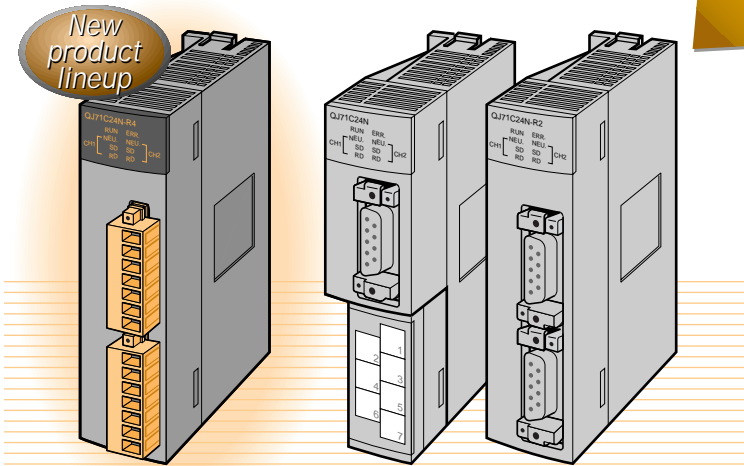

QJ71C24N-R4
CH1:RS-422/485
CH2:RS-422/485

QJ71C24N
CH1:RS-232
CH2:RS-422/485

QJ71C24N-R2
CH1:RS-232
CH2:RS-232

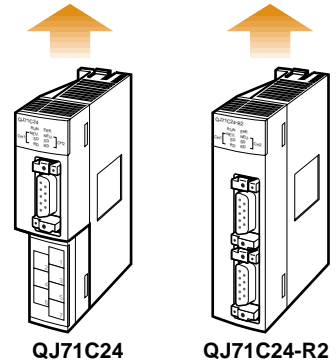

QJ71C24

QJ71C24-R2

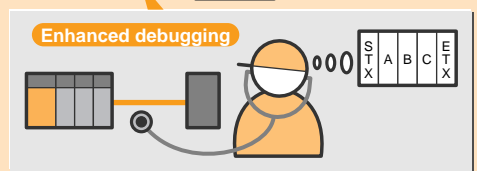
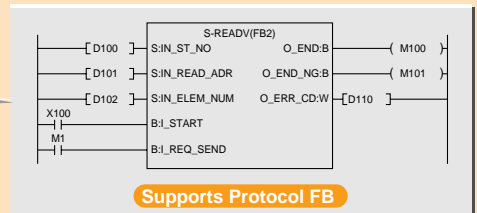

GX Configurator-SC Version 2 is ideal in these features!

Protocol FB
Reduces programming steps.

Debugging
Is improved by line monitor and communication test.

(1) QJ71C24N, QJ71C24N-R2, QJ71C24N-R4 Serial Communication Modules

(a) Upto 230,400 bps transmission speed

The total speed for 2 channels is now 230,400 bps. *1

Thus, using 2 channels simultaneously enables high-speed communication at a maximum speed of 115,200 bps for each channel.

*1 230,400 bps is available only for the CH1 side.

(b) Support for circuit trace and communication test of GX Configurator-SC Version 2

GX Configurator-SC Version 2 together with the QJ71C24N (-R2/R4) allows the circuit trace function to monitor the send/receive data.

The communication test function of GX Configurator-SC Version 2 also reduces debugging steps.

(2) GX Configurator-SC Version 2

The GX Configurator-SC Version 2 utility software makes communication control programming and debugging easier for the QJ71C24N (-R2/R4). *2

*2 The QJ71C24 and QJ71C24-R2 are also supported. (See "GX Configurator-SC Version 2 and Functional Range applicable models.")

(a) Protocol FB function

[1] Function blocks (FB) reduce communication control program steps.

Without creating complicated sequence programs, equivalent function block programs can be created only by making simple on-screen settings. By incorporating the created function blocks into existing sequence programs, programming steps can be reduced.

GX Configurator-SC Version2 (Including Protocol FB Function)

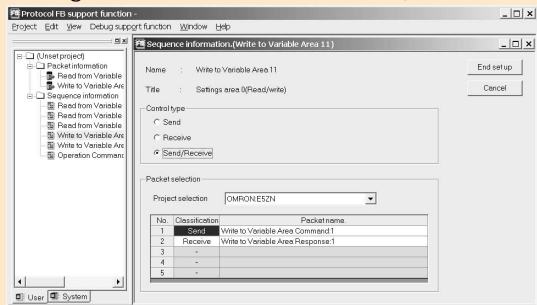

Set packet information, packet data and PLC information on each screen.

Convert to FB

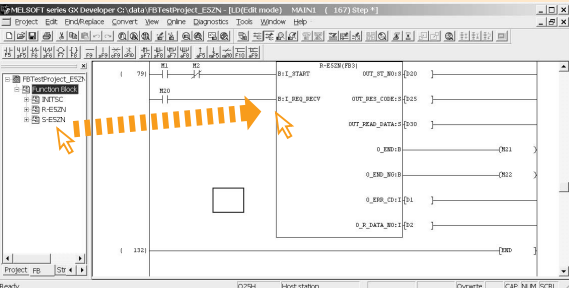

Paste a function block from the project tree to a program by drag and drop.

[2] Support for function blocks to communicate with controllers manufactured by other companies

Controllers manufactured by other companies are supported by providing function blocks preset with the packet information, packet data, and PLC information required for communication. This eliminates the requirement for any additional special settings.

(b) Debug function

Debugging work at system startup can be simplified by using the debug support function.

[Status monitor]
Checks the module status.

[Circuit trace]
Available for QJ71C24N (-R2/R4) only
Traces the send/receive packet data on a communication line and the status of the communication signal line.

QJ71C24N (-R2/R4) External device

[Communication test]
Available for QJ71C24N (-R2/R4) only
Tests the communication by sending user-specified packet data to the external device.

GX Configurator-SC Version2

Serial Communication Modules Function List

(1) Serial communication module basic functions

Function	Description
Communication by MC protocol QnA compatible 2C/3C/4C frame A compatible 1C frame	Reads/writes the PLC CPU data from/to the external device.
Communication by Non Procedure protocol	Sends/receives data using the protocol format of the external device.
Communication by bidirectional protocol	Sends/receives data using the message format and transmission control procedure for the bidirectional protocol between the PLC CPU and external device.
Connection to PC running GX Developer	Performs programming, monitoring and testing of the PLC CPU.

(2) Serial communication module application functions

Function	Description*	
Data transmission by PLC CPU monitoring function	Monitors the PLC CPU, and transmits the monitored information for notification.	MC Non Procedure
Data communication by modem function	Performs data communication via a modem with the remote device.	MC Non Procedure Bidirectional GX Dev
	Remote password check	Prevents illegal access to the QCPU from the remote device. MC GX Dev
Call back	Enables to reconnect (call back) the line from the serial communication module side after the line is connected from GX Developer. GX Dev	
Data reception by interrupt program	Enables data reception using interrupt programs while receiving another data. Non Procedure Bidirectional	
Data communication using the user frame	Registers the fixed format part of send/receive data as a user frame to facilitate data communication. MC Non Procedure	
Data communication by ASCII-to-binary conversion	Sends/receives ASCII data by ASCII-to-binary conversion. Non Procedure Bidirectional	
Data communication by specifying transparent code	Enables to send/receive transmission control data as user data. Non Procedure Bidirectional	
Mode switching	Enables to switch the communication protocol of the serial communication module by the external device or PLC CPU. MC Non Procedure Bidirectional GX Dev	
NEW Send/receive data monitoring	Enables to trace communication data. GX Configurator-SC screen displays communication timing waveform of the traced data. MC Non Procedure Bidirectional GX Dev	

* Protocols for application functions **MC** : MC protocol, **Non Procedure** : Non Procedure protocol, **Bidirectional** : Bidirectional protocol, **GX Dev** : GX Developer
Each interface of the serial communication module operates independently. It is also possible to use two interfaces simultaneously.

Serial Communication Modules Performance Specifications

Item		Specifications																	
		QJ71C24N	QJ71C24N-R2	QJ71C24N-R4															
Interface	CH1	RS-232-compliance (D-sub 9P)	RS-232-compliance (D-sub 9P)	RS-422/485-compliance (2-piece plug-in connector socket block)															
	CH2	RS-422/485-compliance (2-piece terminal block)	RS-232-compliance (D-sub 9P)	RS-422/485-compliance (2-piece plug-in connector socket block)															
Communication method		Full duplex communication/half duplex communication																	
Synchronization method		Asynchronous method																	
Transmission speed		<table border="1"> <tr> <td>50</td> <td>300</td> <td>600</td> <td>1200</td> <td>2400</td> <td>4800</td> <td>9600</td> </tr> <tr> <td>14400</td> <td>19200</td> <td>28800</td> <td>38400</td> <td>57600</td> <td>115200</td> <td>230400</td> </tr> </table> (bps) <ul style="list-style-type: none"> Transmission speed 230400 bps is available for only CH1. (Not available for CH2) Total transmission speed of two interfaces is available up to 230400 bps. Transmission speed of up to 115200 bps for each interface is available when two interface are used simultaneously. 			50	300	600	1200	2400	4800	9600	14400	19200	28800	38400	57600	115200	230400	
50	300	600	1200	2400	4800	9600													
14400	19200	28800	38400	57600	115200	230400													
Data format	Start bit	1																	
	Data bit	7/8																	
	Parity bit	1(vertical parity) or none																	
	Stop bit	1/2																	
Access cycle	MC protocol communication	Processes one request during installed PLC CPU END processing. • Number of scans that must be processed/number of link scans depends on the contents of the request.																	
	Nonprocedural protocol communication	Sends each time a send request is issued. Can receive at any time.																	
	Bidirectional protocol communication																		
Error detection	Parity check	For all protocol, select odd/even by the parameter when there is an error.																	
	Sum check code	Select by the parameter for MC protocol/Bidirectional protocol. Select by the user frame for non-procedure protocol.																	
Transmission control		<table border="1"> <thead> <tr> <th></th> <th>RS-232</th> <th>RS-422/485</th> </tr> </thead> <tbody> <tr> <td>DTR/DSR (ER/DR) control</td> <td>○</td> <td>×</td> </tr> <tr> <td>RS/CS control</td> <td>○</td> <td>×</td> </tr> <tr> <td>CD signal control</td> <td>○</td> <td>×</td> </tr> <tr> <td>DC1/DC3 (Xon/Xoff) control, DC2/DC4 control</td> <td>○</td> <td>○</td> </tr> </tbody> </table> <ul style="list-style-type: none"> DTR/DSR signal control and DC code control are selected by the user. 				RS-232	RS-422/485	DTR/DSR (ER/DR) control	○	×	RS/CS control	○	×	CD signal control	○	×	DC1/DC3 (Xon/Xoff) control, DC2/DC4 control	○	○
	RS-232	RS-422/485																	
DTR/DSR (ER/DR) control	○	×																	
RS/CS control	○	×																	
CD signal control	○	×																	
DC1/DC3 (Xon/Xoff) control, DC2/DC4 control	○	○																	
Line configuration(*1)	RS-232	1:1	1:1	-															
	RS-422/485	1:1, 1:n, n:1, m:n	-	1:1, 1:n, n:1, m:n															
Max. transmission distance (overall distance)	RS-232	15 m (49.2 ft.)	15 m (49.2 ft.)	-															
	RS-422/485	1200 m (4592.4 ft.) (overall distance)	-	1200 m (4592.4 ft.) (overall distance)															
Max. number of writes for flash ROM		100,000 writes to the same area																	
Number of occupied I/O points		32 points per slot (I/O assignment: Intelli: 32 points)																	
Recommended cable	RS-232	7/0. 127 nP HRV-SV Outside diameter 8.5mm (0.33in.) or more (Oki Electric Cable Co., Ltd. n:number of pairs)																	
	RS-422/485 (*2)	SPEV (SB)-MPC-0.2 x 3P Outside diameter approx. 6.5mm (0.26 in.) (Mitsubishi Cable Industries, LTD.) SPEV(SB)-0.2 x 3P Outside diameter approx. 7.5mm (0.3 in.) (Mitsubishi Cable Industries, LTD.)																	
Applicable connector for external wiring		9 pin D-sub (male) screw type		-															
5V DC internal current consumption		0.31A	0.26A	0.39A															
External dimensions		98(3.86in.)(H) x 27.4(1.08in.)(W) x 90(3.54in.)(D)[mm]																	
Weight		0.20kg (0.44lb)																	

*1 Indicates possible combinations when connecting the PLC CPU and external devices (external device side: PLC CPU side). The total number of n and m+n is up to 32 stations.

*2 Recommended cables SPEV (SB)-MPC-0.2 x 3P and SPEV (SB)-0.2 x 3P have the same electrical characteristics, but their external dimensions and internal wire colors are different.

External Dimensions

(1) QJ71C24N

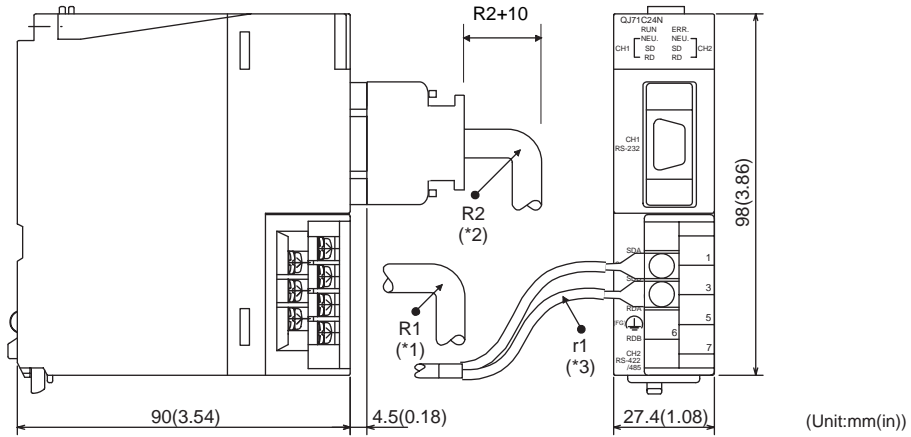

- *1 R1 (Bend radius near terminal block) : Cable diameter x 4
- *2 R2 (Bend radius near connector) : Cable diameter x 4
- *3 r1 (Bend radius near crimping terminal) : Connectable to the degree with no excessive bending of the cable

(2) QJ71C24N-R2

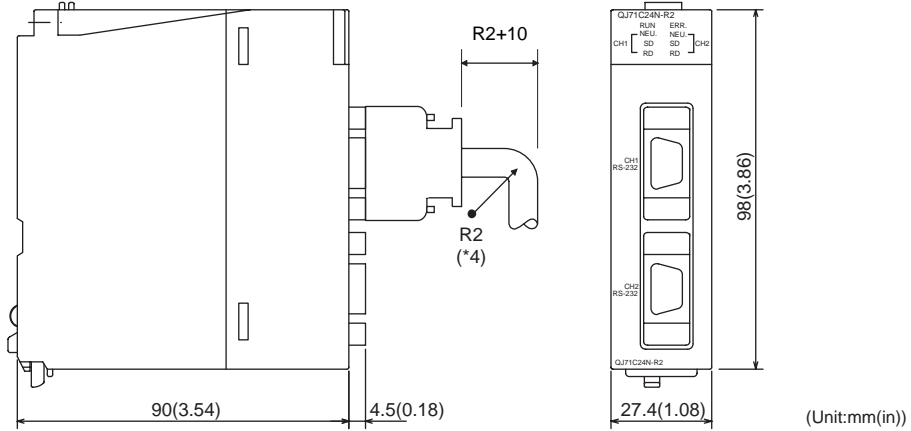

- *4 R2 (Bend radius near connector) : Cable diameter x 4

(3) QJ71C24N-R4

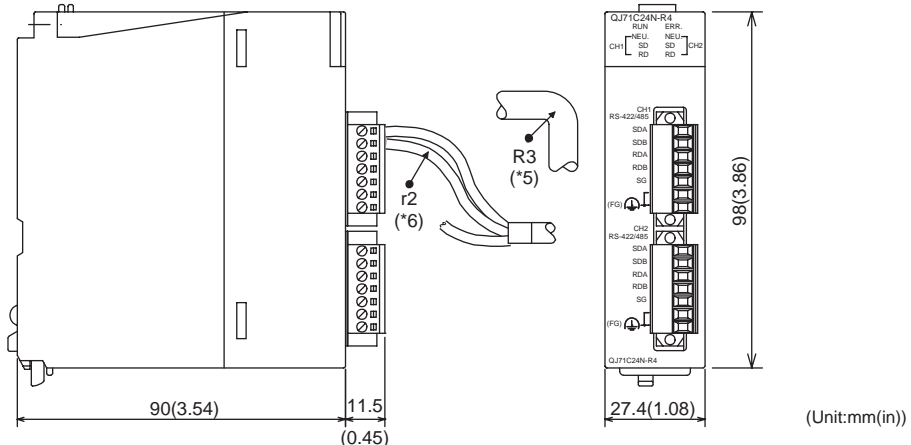

- *5 R3 (Bend radius near the plug-in socket block) : cable diameter x 4
- *6 r2 (Bend radius near the wire connector) : Connectable to the degree with no excessive bending of the cable

GX Configurator-SC Version 2 Function List

(1) Protocol FB function

Function	Description
Module setting	Initial settings of the module.
Packet configuration setting	Sets the packet configuration of the external device.
Packet data information setting	Sets the details for each configuration element of data to be transmitted/received.
Sequence information setting	Sets communication sequence information for the serial communication module.
Sequence FB conversion	Creates a protocol FB.

(2) Debug function

Function	Description
Circuit trace	Monitors send/receive packet data and traces the status of communication signal line.
Communication test	Performs a communication test from the serial communication module to the external device.
Status monitor	Monitors the error status, communication signal line, etc. of the serial communication module.

(3) Intelligent function utility

Function	Description
Auto refresh setting	Stores the operation status, error code etc., of the serial communication module into the internal device memory of the PLC CPU.
System setting	Performs various settings for data communication with the external device.
Monitor/test	Performs the monitoring/testing of various setting values stored in buffer memory.

GX Configurator-SC Version 2 and Functional Range applicable models

Model	Circuit trace	Debug support function			Intelligent function utility
		Communication timing waveform	Communication test	Status monitor	
QJ71C24N, QJ71C24N-R2, QJ71C24N-R4	○	○	○	○	○
QJ71C24, QJ71C24-R2	○	×	×	○	○

GX Configurator-SC Version 2 Operating Environment

Item	Peripheral device
Installation (Add-in) destination *1	Add-in to GX Developer Version 8 or later *2
Personal Computer	IBM-PC/AT compatible personal computer installed with applicable OS.
	CPU
	Required memory
	See the following table "Operation Systems and Performance Required for PCs."
Available hard disk space	For installation
	For operation
Display resolution	800 x 600 pixels or higher *3
Operating system	Microsoft® Windows®95 Operating System (English version) Microsoft® Windows®98 Operating System (English version) Microsoft® Windows®Millennium Edition Operating System (English version) Microsoft® Windows NT® Workstation Operating System Version 4.0 (English version) Microsoft® Windows®2000 Professional Operating System (English version) Microsoft® Windows®XP Professional Operating System (English version) Microsoft® Windows®XP Home Edition Operating System (English version)

* 1 Install GX Configurator-SC to GX Developer Version 8 or later of the same language.

However, when using only the intelligent function utility, it can be added into GX Developer Version 4 or later.

Using the Japanese version of GX Developer together with the English version of GX Configurator-SC, or using the English version of GX Developer together with the Japanese version of GX Configurator-SC is not allowed.

* 2 GX Configurator-SC is not applicable to GX Developer Version 3 or earlier.

* 3 When Windows® XP Professional or Windows® XP Home Edition is used, large font sizes are not supported.

Operation Systems and Performance Required for PCs

Operating Software		Performance required for Personal Computer	
		CPU	Required memory
Windows®95 (Service pack 1 or more)		Pentium®133MHz or higher	32MB or more
Windows®98		Pentium®133MHz or higher	32MB or more
Windows®Me		Pentium®150MHz or higher	32MB or more
Windows NT® Workstation 4.0 (Service pack 3 or more)		Pentium®133MHz or higher	32MB or more
Windows®2000 Professional		Pentium®133MHz or higher	64MB or more
Windows®XP Professional	*XP Compatible Mode* and *Simplified User Switching* are not supported.	Pentium®300MHz or higher	128MB or more
Windows®XP Home Edition		Pentium®300MHz or higher	128MB or more

Product List

(1) Serial Communication Modules

Product name	Model
QJ71C24N serial communication module	QJ71C24N
QJ71C24N-R2 serial communication module	QJ71C24N-R2
QJ71C24N-R4 serial communication module	QJ71C24N-R4

(2) GX Configurator-SC Version 2

(a) Single license products

Product name	Model	Remarks
GX Configurator-SC Version2 (English Version) Single license product	SW2D5C-QSCU-E	CD-ROM (SW2D5C-QSCU-E) x 1 Including manual (English version) License agreement x 1 Software license agreement x 1 Software registration form x 1

(b) Volume license products

You can specify 2+ volume license. Please contact your local Mitsubishi service or representative for details.

Product name	Model	Remarks
GX Configurator-SC Version2 (English Version) Volume license product	SW2D5C-QSCU-EA	CD-ROM (SW2D5C-QSCU-E) x 1 Including manual (English version) License agreement x 1 Software license agreement x 1 Software registration form x n *1

*1 "n" is the same as the number of licenses.

(c) Additional license products

Product name	Model	Remarks
GX Configurator-SC Version2 (English Version) Additional license product	SW2D5C-QSCU-EAZ	License agreement x 1 Software license agreement x 1 Software registration form x n *1

*1 "n" is the same as the number of licenses.

Manual name	Manual supply status	IB/SH No. (following version or later manual)	Model code
Serial Communication Module User's Manual (Hardware)	Included with product	IB-0800008-D	13JQ31
Q Corresponding Serial Communication Module User's Manual (Basic)	Sold separately *1	SH-080006-F	13JL86
Q Corresponding Serial Communication Module User's Manual (Application)	Sold separately	SH-080007-D	13JL87
Q Corresponding MELSEC Communication Protocol Reference Manual	Sold separately	SH-080008-D	13JF89
GX Configurator-SC Version2 Operating Manual (Protocol FB support function)	Sold separately *1	SH-080393E-A	13JU46

*1 This product includes the manual data in PDF format on the CD containing the software package. (Acrobat Reader, the software needed to view PDF format document on a personal computer is also included on the CD-ROM.) The printed material is available separately.

Microsoft, Windows, Windows NT are registered trademarks of Microsoft Corporation in the United States and other countries.
 Adobe and Acrobat are registered trademarks of Adobe Systems Incorporated.
 Pentium and Celeron are trademarks of Intel Corporation in the United States and other countries.
 Other company names and product names used in this document are the trademarks or registered trademarks of their respective owners.

VS-VIEW
 Copyright(C)2001 ComponentOne LLC
 VS-FlexGrid Pro
 Copyright(C)2000 VideoSoft Corporation
 SPREAD
 Copyright(C)1996 FarPoint Technologies, Inc.

Country/Region	Sales office	Tel/Fax			
U.S.A	Mitsubishi Electric Automation Inc. 500 Corporate Woods Parkway Vernon Hills, IL 60061	Tel : +1-847-478-2100 Fax : +1-847-478-0328	China	Ryoden International Shanghai Ltd. 3F Block5 Building Automation Instrumentation Plaza 103 Cao Bao Rd. Shanghai 200233 China	Tel : +86-21-6475-3228 Fax : +86-21-6484-6996
Brazil	MELCO-TEC Rep. Com.e Assessoria Tecnica Ltda. Av. Rio Branco, 123-15 ,and S/1507, Rio de Janeiro, RJ CEP 20040-005, Brazil	Tel : +55-21-221-8343 Fax : +55-21-221-9388	Taiwan	Setsuyo Enterprise Co., Ltd. 6F., No.105 Wu-Kung 3rd.RD, Wu-Ku Hsiang, Taipei Hsine, Taiwan	Tel : +886-2-2299-2499 Fax : +886-2-2299-2509
Germany	Mitsubishi Electric Europe B.V. German Branch Gothaer Strasse 8 D-40880 Ratingen, GERMANY	Tel : +49-2102-486-0 Fax : +49-2102-486-717	Korea	HAN NEUNG TECHNO CO., LTD. 1F Dong Seo Game Channel Bldg., 660-11,Deungchon-dong Kangsec-ku, Seoul, Korea	Tel : +82-2-3660-9552 Fax : +82-2-3664-8372
U.K	Mitsubishi Electric Europe B.V. UK Branch Travellers Lane, Hatfield, Herts., AL10 8XB,UK	Tel : +44-1707-276100 Fax : +44-1707-278695	Singapore	Mitsubishi Electric Asia Pte, Ltd. 307 Alexandra Road #05-01/02, Mitsubishi Electric Building Singapore 159943	Tel : +65-473-2480 Fax : +65-476-7439
Italy	Mitsubishi Electric Europe B.V. Italian Branch Centro Dir. Colleoni, Pal. Perseo - Ingr.2 Via Paracelso 12, 20041 Agrate B., Milano, Italy	Tel : +39-039-60531 Fax : +39-039-6053312	Thailand	F. A. Tech Co.,Ltd. 898/28,29,30 S.V.City Building, Office Tower 2, Floor 17-18 Rama 3 Road, Bangkokpongpan, Yannawa, Bangkok 10120	Tel : +66-2-682-6522 Fax : +66-2-682-6020
Spain	Mitsubishi Electric Europe B.V. Spanish Branch Carretera de Rubi 76-80 08190-Sant Cugat del Valles, Barcelona, Spain	Tel : +34-935-653135 Fax : +34-935-891579	Indonesia	P.T. Autoteknindo SUMBER MAKMUR Jl. Muara Karang Selatan Blok a Utara No.1 Kav. No.11 Kawasan Industri/Pergudangan Jakarta-Utara 14440	Tel : +62-21-663-0833 Fax : +62-21-663-0832
South Africa	Circuit Breaker Industries LTD. Private Bag 2016, Isando 1600, Johannesburg, South Africa	Tel : +27-11-928-2000 Fax : +27-11-392-2354	India	Messung Systems Put.Ltd. Electronic Sadan NO:111 Unit No15, M.I.D.C BHOSARI,PUNE-411026,India	Tel : +91-20-7128927 Fax : +91-20-7128108
Hong Kong	Ryoden Automation Ltd. 10th Floor, Manulife Tower, 169 Electric Road, North Point, HongKong	Tel : +852-2887-8870 Fax : +852-2887-7984	Australia	Mitsubishi Electric Australia Pty, Ltd. 348 Victoria Road, PostalBag, No 2, Rydalmere, N.S.W 2116, Australia	Tel : +61-2-9684-7777 Fax : +61-2-9684-7245



HEAD OFFICE: 1-8-12, OFFICE TOWER Z 14F HARUMI CHUO-KU 104-6212, JAPAN
 NAGOYA WORKS: 1-14, YADA-MINAMI 5, HIGASHI-KU, NAGOYA, JAPAN

Specifications subject to change without notice.
 Printed in Japan on recycled paper.