

MITSUBISHI

MODEL GT15-QBUS/GT15-QBUS2/ GT15-ABUS/GT15-ABUS2 BUS CONNECTION UNIT

User's Manual

Thank you for purchasing the GOT1000 Series.

Prior to use, please read both this manual and detailed manual thoroughly to fully understand the product.

MODEL	GT15-BUS-U
MODEL CODE	1D7M39
IB(NA)-0800323-D(0610)MEE	

GRAPHIC OPERATION TERMINAL
GOT1000

SAFETY PRECAUTIONS

(Always read these precautions before using this equipment.)

Before using this product, please read this manual and the relevant manuals introduced in this manual carefully and pay full attention to safety to handle the product correctly. The precautions given in this manual are concerned with this product. In this manual, the safety precautions are ranked as "DANGER" and "CAUTION".

DANGER Indicates that incorrect handling may cause hazardous conditions, resulting in death or severe injury.

CAUTION Indicates that incorrect handling may cause hazardous conditions, resulting in medium or slight personal injury or physical damage.

Note that the CAUTION level may lead to a serious accident according to the circumstances. Always follow the precautions of both levels because they are important to personal safety. Please save this manual to make it accessible when required and always forward it to the end user.

DESIGN PRECAUTIONS

CAUTION

- Do not bunch the control wires or communication cables with the main circuit or power wires, or lay them close to each other. As a guide, separate the lines by a distance of at least 100 mm (3.94 inch) otherwise malfunctions may occur due to noise.

INSTALLATION PRECAUTIONS

DANGER

- Before mounting or dismounting this unit to or from the GOT, always shut off GOT power externally in all phases. Not doing so can cause a unit failure or malfunction.

CAUTION

- Use this unit in the environment given in the general specifications of the GT15 User's Manual. Not doing so can cause an electric shock, fire, malfunction or product damage or deterioration.
- When installing this unit to the GOT, fit it to the connection interface of the GOT and tighten the mounting screws in the specified torque range. Undertightening can cause a drop, failure or malfunction. Overtightening can cause a drop, failure or malfunction due to screw or unit damage.

WIRING PRECAUTIONS

DANGER

- Before connecting the Bus connection cable to this unit, always shut off GOT power and PLC CPU power externally in all phases. Not doing so can cause a malfunction.

CAUTION

- Insert and fit the bus connection cable into the connector of the unit to be connected until it "clicks". After fitting, check for lift which can cause a malfunction due to a connection fault.

STARTUP AND MAINTENANCE PRECAUTIONS

DANGER

- Before starting cleaning, always shut off GOT power externally in all phases. Not doing so can cause a unit failure or malfunction.

CAUTION

- Do not disassemble or modify any unit. This will cause failure, malfunction, injuries, or fire.
- Do not touch the conductive areas and electronic parts of this unit directly. Doing so can cause a unit malfunction or failure.
- Always secure the cables connected to the unit, e.g. run them in conduits or clamp them. Not doing so can cause unit or cable damage due to dangling, moved or accidentally pulled cables or can cause a malfunction due to a cable contact fault.
- Do not hold the cable part when unplugging any cable connected to the unit. Doing so can cause unit or cable damage or a malfunction due to a cable contact fault.
- Always make sure to touch the grounded metal to discharge the electricity charged in the body, etc., before touching the unit. Failure to do so may cause a failure or malfunctions of the unit.

DISPOSAL PRECAUTIONS

CAUTION

- Dispose of this product as industrial waste.

TRANSPORTATION PRECAUTIONS

CAUTION

- Make sure to transport the GOT main unit and/or relevant unit(s) in the manner they will not be exposed to the impact exceeding the impact resistance described in the general specifications of the GT15 User's Manual, as they are precision devices. Failure to do so may cause the unit to fail. Check if the unit operates correctly after transportation.

Manuals

The following shows manuals relevant to this product.

Detailed Manual

Manual name	Manual Number (Type code)
GT15 User's Manual (Option)	SH-080528ENG (1D7M23)
GOT1000 Series Connection Manual (Option)	SH-080532ENG (1D7M26)

Relevant Manuals

For relevant manuals, refer to the PDF manual stored within the drawing software used.

© 2005 MITSUBISHI ELECTRIC CORPORATION

Compliance with the EMC and Low Voltage Directives

When incorporating the Mitsubishi GOT into other machinery or equipment and keeping compliance with the EMC and low voltage directives, refer to "EMC AND LOW VOLTAGE DIRECTIVE" of the GT15 User's Manual.

The CE logo is printed on the rating plate of the GOT, indicating compliance with the EMC and low voltage directives. By making this product conform to the EMC directive and low voltage instruction, it is not necessary to make those steps individually.

Product Components

The bus connection unit consists of the following items.

Model name	Product name	Quantity
GT15-QBUS, GT15-ABUS	Either GT15-QBUS or GT15-ABUS A set of screws (2 screws, 2 labels)	1
GT15-QBUS2, GT15-ABUS2	Either GT15-QBUS2 or GT15-ABUS2 A set of screws (2 screws, 2 labels)	2
	Extension interface relay board	1

1. Overview

This User's Manual describes the GT15 bus connection unit (hereinafter abbreviated as bus connection unit). There are the following bus connection unit types. Refer to the GT15 User's Manual for the applicable GOT.

Product name	Model name	Description
Bus connection unit	GT15-QBUS	QCPU (Q Mode) bus connection Number of connectors: 1
	GT15-QBUS2	QCPU (Q Mode) bus connection Number of connectors: 2
	GT15-ABUS	QnA/ACPU bus connection Number of connectors: 1
	GT15-ABUS2	QnA/ACPU bus connection Number of connectors: 2

Use the bus connection unit for making bus connection of the GOT. Select the used bus connection unit according to the connection target and connection position.

Bus connection unit selection example

- Select the bus connection unit according to the connection target.

- QCPU (Q Mode), motion controller Q series : GT15-QBUS/GT15-QBUS2
- ACPU, QnACPU, motion controller A series : GT15-ABUS/GT15-ABUS2

- Select the bus connection unit according to the GOT connection position.

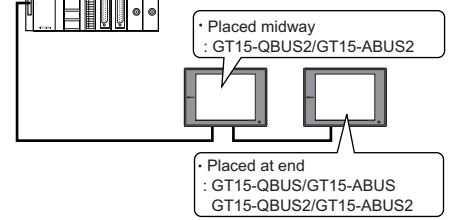

When using the bus connection, make the communication settings to perform communication between the GOT and PLC. Refer to the GOT1000 Series Connection Manual for details of bus connection.

When using bus connection unit, use a standard monitor OS and communication driver of GT Designer2 Version2.15R or later. With a standard monitor OS and communication driver of an older version, the GOT has not recognize the unit to perform monitoring.

2. Specifications

The performance specifications of the bus connection unit are indicated below. Refer to the used GT15 User's Manual for the general specifications of the bus connection unit.

Item	GT15-QBUS	GT15-QBUS2	GT15-ABUS	GT15-ABUS2
I/O occupied points	16 points (I/O assignment: 16 intelligent points)		32 points (I/O assignment: Special 32 points)	
Internal consumed current (DC5V)*	0.44A	0.44A	0.12A	0.12A
Weight	0.13kg	0.14kg	0.13kg	0.14kg

* When the GOT power is on, the internal current consumption is included in the current consumption of the GOT. When the GOT power is off, the internal current is supplied from the power supply of the PLC system.

3. Part Names and External Dimensions

(1) GT15-QBUS, GT15-ABUS

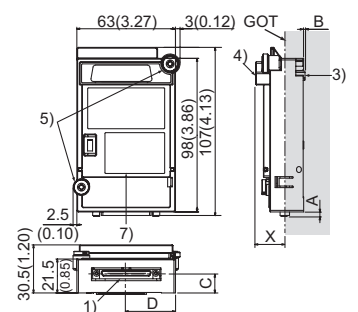

(2) GT15-QBUS2, GT15-ABUS2

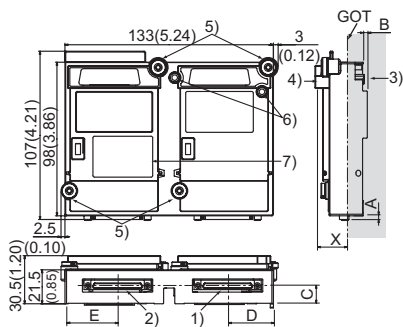

Extension interface relay board

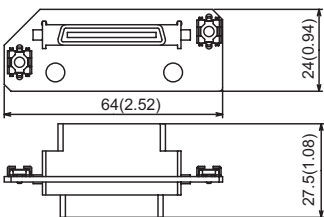

MODEL	A	B	C	D	E
GT15-QBUS	2.3 (0.09)	0.5 (0.02)	12 (0.47)	31.5 (1.24)	-
GT15-QBUS2	2.5 (0.10)	3.0 (0.12)	11 (0.43)	29 (1.14)	33.5 (1.32)
GT15-ABUS	4.5 (0.18)	0.8 (0.03)	15 (0.59)	29.5 (1.16)	-
GT15-ABUS2	4.5 (0.18)	3.0 (0.12)	11 (0.43)	31 (1.22)	31 (1.22)

Unit: mm (inch)

Dimensions of X when mounted to the GOT.

15", 10.4"	21 (0.83)
12.1"	18 (0.71)
8.4", 5.7"	23 (0.91)

Unit: mm (inch)

No.	Name	Description
1)	Bus connector (IN side)	Connector for connecting the bus connection cable (IN side)
2)	Bus connector (OUT side)	Connector for connecting the bus connection cable (OUT side)
3)	Interface connector	Extension connector installed to a front extension unit or the GOT
4)	Extension connector	Extension connector to which a back extension unit is installed
5)	Mounting screw	Mounting screws fixed with a front extension unit or GOT
6)	Board fixing screw	Screw for fixing the extension interface relay board
7)	Rating plate	-

4. Installation Procedure

(1) GT15-QBUS, GT15-ABUS

- Power off the GOT.
- Remove the two expansion unit covers of the GOT.

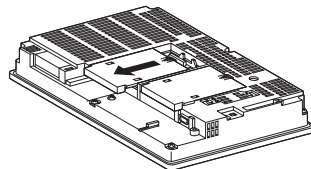

- Fit the bus connection unit along the groove of the GOT case.

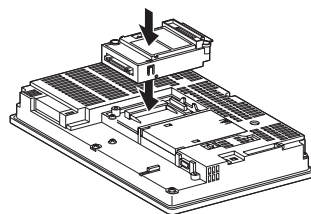

- Fasten the bus connection unit by tightening its mounting screws (2 places) with tightening torque 0.36 to 0.48 N·m.

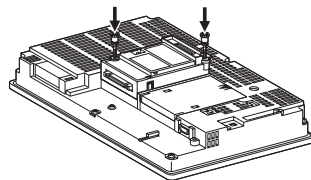

- When installing an extension unit on the unit that has been installed, remove the connector cover and the seal.

When not installing an extension unit on the unit that has been installed, in order to avoid receiving electrostatic, stick accessory labels to cover the top of mounting screws (2 places). Keep the connector cover fixed. Keep the seal stuck as it is.

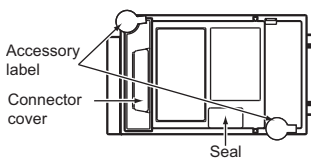

(2) GT15-QBUS2, GT15-ABUS2

- Power off the GOT.
- Remove the two expansion unit covers of the GOT.

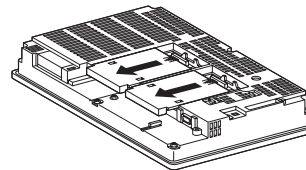

- Attach the extend interface relay board to the extend I/F-2 side on the GOT. For GT15□, the extension interface relay board is not needed.
- Fit the bus connection unit along the groove of the GOT case.

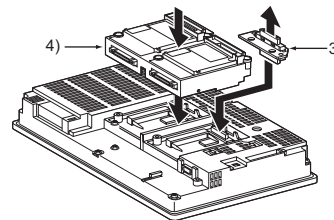

- Fasten the bus connection unit by tightening its mounting screws (4 places) with tightening torque 0.36 to 0.48 N·m.
- Fasten the bus connection unit by tightening the board fixing screws (2 places) with the tightening torque of 0.36 to 0.48 N·m.

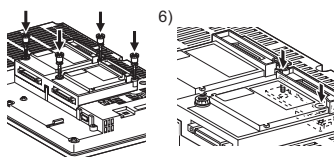

- When installing an extension unit on the unit that has been installed, remove the connector cover and the seal. When not installing an extension unit on the unit that has been installed, in order to avoid receiving electrostatic, stick accessory labels to cover the top of mounting screws (4 places). Keep the connector cover fixed. Keep the seal stuck as it is.

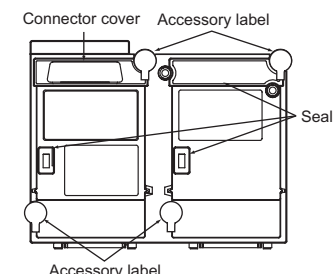

Point

Remove the screws that fixes the extend interface relay board before removing the unit. (Above 6))

Warranty

Mitsubishi will not be held liable for damage caused by factors found not to be the cause of Mitsubishi; machine damage or lost profits caused by faults in the Mitsubishi products; damage, secondary damage, accident compensation caused by special factors unpredictable by Mitsubishi; damages to products other than Mitsubishi products; and to other duties.

For safe use

- This product has been manufactured as a general-purpose part for general industries, and has not been designed or manufactured to be incorporated in a device or system used in purposes related to human life.
- Before using the product for special purposes such as nuclear power, electric power, aerospace, medicine or passenger movement vehicles, consult with Mitsubishi.
- This product has been manufactured under strict quality control. However, when installing the product where major accidents or losses could occur if the product fails, install appropriate backup or failsafe functions in the system.

Country/Region Sales office/Tel

U.S.A	Mitsubishi Electric Automation Inc. 500 Corporate Woods Parkway Vernon Hills, IL 60061, U.S.A. Tel : +1-847-478-2100
Brazil	MELCO-TEC Rep. Com.e Assessoria Tecnica Ltda. Rua Correia Dias, 184, Edificio Paraiso Trade Center-8 andar Paraiso, Sao Paulo, SP Brazil Tel : +55-11-5908-8331
Germany	Mitsubishi Electric Europe B.V. German Branch Golthaer Strasse 8 D-40880 Ratingen, GERMANY Tel : +49-2102-486-0
U.K	Mitsubishi Electric Europe B.V. UK Branch Travellers Lane, Hatfield, Hertfordshire, AL10 8XB, U.K. Tel : +44-1707-276100
Italy	Mitsubishi Electric Europe B.V. Italian Branch Centro Dir. Colleoni, Pal. Perseo-Ing.2 Via Paracelso 12, I-20041 Agrate Brianza, Milano, Italy Tel : +39-039-60531
Spain	Mitsubishi Electric Europe B.V. Spanish Branch Carretera de Ruda 76-80, E-08190 Sant Cugat del Valles, Barcelona, Spain Tel : +34-93-565-3131
France	Mitsubishi Electric Europe B.V. French Branch 25, Boulevard des Bouvets, F-92741 Nanterre Cedex, France TEL : +33-1-5568-5568
South Africa	Circuit Breaker Industries Ltd. Private Bag 2016, ZA-1600 Isando, South Africa Tel : +27-11-828-2000
Hong Kong	Mitsubishi Electric Automation (Hong Kong) Ltd. 10th Floor, Manulife Tower, 169 Electric Road, North Point, Hong Kong Tel : +852-2887-8870
China	Mitsubishi Electric Automation (Shanghai) Ltd. 4/F Zhi Fu Plaza, No.80 Xin Chang Road, Shanghai 200003, China Tel : +86-21-6120-0808
Taiwan	Setsuyo Enterprise Co., Ltd. 6F No.105 Wu-Kung 3rd.Rd, Wu-Ku Hsiang, Taipei Hsine, Taiwan Tel : +886-2-2299-2499
Korea	Mitsubishi Electric Automation Korea Co., Ltd. 1480-6, Gayang-dong, Gangseo-ku Seoul 157-200, Korea Tel : +82-2-3660-9552
Singapore	Mitsubishi Electric Asia Pte. Ltd. 307 Alexandra Road #05-01/02, Mitsubishi Electric Building, Singapore 159943 Tel : +65-6470-2460
Thailand	Mitsubishi Electric Automation (Thailand) Co., Ltd. Bang-Chan Industrial Estate No.111 Moo 4, Serithai Rd, T.Kannayao, A.Kannayao, Bangkok 10230 Thailand Tel : +66-2-517-1326
Indonesia	P.T. Autoteknindo Sumber Makmur Muara Karang Selatan, Block A/Utara No.1 Kav. No.11 Kawasan Industri Pergudangan Jakarta - Utara 14440, P.O.Box 5045 Jakarta, 11050 Indonesia Tel : +62-21-6830833
India	Messung Systems Pvt. Ltd. Electronic Sadan NO-III Unit No15, M.I.D.C Bhosari, Pune-411026, India Tel : +91-20-2712-3130
Australia	Mitsubishi Electric Australia Pty. Ltd. 348 Victoria Road, Rydalmere, N.S.W 2116, Australia Tel : +61-2-9684-7777

MITSUBISHI ELECTRIC CORPORATION
HEAD OFFICE : TOKYO BUILDING, 2-7-3 MARUNOUCHI, CHYODA-KU, TOKYO 100-8310, JAPAN
NAGOYA WORKS : 1-14, YADA-MINAMI 5-CHOME, HIGASHI-KU, NAGOYA, JAPAN

When exported from Japan, this manual does not require application to the Ministry of Economy, Trade and Industry for service transaction permission.

Specifications subject to change without notice.
Printed in Japan on recycled paper.