



fail-safe digital module DM-F local, for fail-safe shutdown via hardware signal Us: 110...240 V AC/DC 2 relay enabling circuits, 2 relay outputs, safety function can be set via DIP switch, maximum achievable SIL IEC 61508: 3, maximum achievable PL ISO 13849-1: E

product brand name	SIMOCODE
product designation	Fail-safe digital module
design of the product	for emergency off and safety doors
product type designation	DM-FL
General technical data	
product function	
<ul style="list-style-type: none"> • EMERGENCY OFF function • automatic start • light barrier monitoring • light array monitoring • protective door monitoring • magnetically operated switch monitoring NC-NO • magnetically operated switch monitoring NC-NC • pressure-sensitive mat monitoring • monitored start-up 	<ul style="list-style-type: none"> Yes Yes Yes Yes Yes Yes Yes Yes Yes
product component	
<ul style="list-style-type: none"> • input for thermistor connection • digital input • input for analog temperature sensors • input for ground fault detection • relay output 	<ul style="list-style-type: none"> No Yes No No Yes
apparent power consumption	9.5 VA
consumed active power	4.5 W
insulation voltage with degree of pollution 3 at AC rated value	300 V
surge voltage resistance rated value	4 000 V
shock resistance according to IEC 60068-2-27	15 g / 11 ms
vibration resistance according to IEC 60068-2-6	1 ... 6 Hz: 15 mm, 6 ... 500 Hz: 2 g
operating frequency maximum	360 1/y
switching capacity current of the NO contacts of the relay outputs at AC-15	
<ul style="list-style-type: none"> • at 24 V • at 120 V • at 240 V 	<ul style="list-style-type: none"> 3 A 3 A 1.5 A
switching capacity current of the NO contacts of the relay outputs at DC-13	
<ul style="list-style-type: none"> • at 24 V • at 60 V • at 125 V • at 250 V 	<ul style="list-style-type: none"> 4 A 0.55 A 0.22 A 0.11 A
switching capacity current of relay enabling circuits at AC-	

15	
<ul style="list-style-type: none"> • at 24 V • at 120 V • at 240 V 	<p>3 A</p> <p>3 A</p> <p>1.5 A</p>
switching capacity current of relay enabling circuits at DC-13	
<ul style="list-style-type: none"> • at 24 V • at 60 V • at 125 V • at 250 V 	<p>4 A</p> <p>0.55 A</p> <p>0.22 A</p> <p>0.11 A</p>
mechanical service life (operating cycles) typical	10 000 000
electrical endurance (operating cycles) typical	100 000
buffering time in the event of power failure	200 ms
recovery time	
<ul style="list-style-type: none"> • after power failure typical • after opening of the safety circuits typical 	<p>8 s</p> <p>250 ms</p>
make time with automatic start	
<ul style="list-style-type: none"> • typical • maximum • at DC maximum • at AC maximum • after power failure typical • after power failure maximum 	<p>50 ms</p> <p>100 ms</p> <p>100 ms</p> <p>100 ms</p> <p>8 000 ms</p> <p>8 200 ms</p>
backslide delay time after opening of the safety circuits typical	50 ms
backslide delay time in the event of power failure	
<ul style="list-style-type: none"> • typical • maximum 	<p>220 ms</p> <p>320 ms</p>
reference code according to IEC 81346-2	F
reference code according to IEC 81346-2:2019	F
type of input characteristic	Type 2 in accordance with EN 61131-2
Substance Prohibition (day/month/year)	05/01/2012
SVHC substance name	Lead CAS-No. 7439-92-1 Lead monoxide (lead oxide) CAS-No. 1317-36-8 2,2',6,6'-tetrabromo-4,4'-isopropylidenediphenol CAS-No. 79-94-7 2-methyl-1-(4-methylthiophenyl)-2-morpholinopropan-1-one CAS-No. 71868-10-5 Melamine CAS-No. 108-78-1 6,6'-di-tert-butyl-2,2'-methylenedi-p-cresol CAS-No. 119-47-1
Net Weight	0.354 kg
Electromagnetic compatibility	
EMC emitted interference according to IEC 60947-1	class A
EMC immunity according to IEC 60947-1	corresponds to degree of severity 3
conducted interference	
<ul style="list-style-type: none"> • due to burst according to IEC 61000-4-4 • due to conductor-earth surge according to IEC 61000-4-5 • due to conductor-conductor surge according to IEC 61000-4-5 • due to high-frequency radiation according to IEC 61000-4-6 	<p>2 kV network connection / 1 kV control connection</p> <p>2 kV</p> <p>1 kV</p> <p>10 V</p>
field-based interference according to IEC 61000-4-3	10 V/m
electrostatic discharge according to IEC 61000-4-2	6 kV contact discharge / 8 kV air discharge
conducted HF interference emissions according to CISPR11	corresponds to degree of severity A
field-bound HF interference emission according to CISPR11	corresponds to degree of severity A
Inputs/ Outputs	
product function	
<ul style="list-style-type: none"> • parameterizable inputs • parameterizable outputs 	<p>Yes</p> <p>Yes</p>
number of inputs	5
design of input	
<ul style="list-style-type: none"> • cascading input/functional switching 	Yes

• feedback input	Yes
• start input	Yes
pulse duration	
• of the sensor input minimum	30 ms
• of the ON pushbutton input minimum	0.2 s
• of the cascading input minimum	0.2 s
number of digital inputs	0
• with a common reference potential	4
digital input version	
• type 1 acc. to IEC 61131	No
• type 2 acc. to IEC 61131	Yes
number of analog inputs	0
number of sensor inputs	
• 1-channel or 2-channel	1
• 2-channel	1
number of outputs	2
number of semiconductor outputs	0
number of outputs as contact-affected switching element	
•	2
• as NO contact safety-related instantaneous contact	2
number of analog outputs	0
switching behavior	monostable
property of contacts of the relay outputs	Fail-safe NO contacts
wire length for digital signals maximum	1 500 m

Product Function

suitability for use	
• position switch monitoring	Yes
• EMERGENCY-OFF circuit monitoring	Yes
• valve monitoring	No
• opto-electronic protection device monitoring	Yes
• tactile sensor monitoring	No
• magnetically operated switch monitoring	Yes
• proximity switch monitoring	No
• safety switch	Yes
• safety-related circuits	Yes

Installation/ mounting/ dimensions

mounting position	any
fastening method	screw and snap-on mounting
height	106 mm
width	45 mm
depth	124 mm
required spacing	
• top	40 mm
• bottom	40 mm
• left	0 mm
• right	0 mm

Connections/ Terminals

product component removable terminal for auxiliary and control circuit	Yes
type of electrical connection for auxiliary and control circuit	screw-type terminals
type of connectable conductor cross-sections	
• solid	1x (0.5 ... 4.0mm ²), 2x (0.5 ... 2.5 mm ²)
• finely stranded with core end processing	1x (0.5 ... 2.5 mm ²), 2x (0.5 ... 1.5 mm ²)
• for AWG cables solid	1x (20 ... 12), 2x (20 ... 14)
• for AWG cables stranded	1x (20 ... 14), 2x (20 ... 16)
tightening torque with screw-type terminals	0.8 ... 1.2 N·m
tightening torque [lbf·in] with screw-type terminals	7 ... 10.3 lbf·in

Ambient conditions

installation altitude at height above sea level	
--	--





<ul style="list-style-type: none"> • 1 maximum • 2 maximum • 3 maximum 	<p>2 000 m</p> <p>3 000 m; max. +50 °C (no protective separation)</p> <p>4 000 m; max. +40 °C (no protective separation)</p>
ambient temperature <ul style="list-style-type: none"> • during operation • during storage • during transport 	<p>-25 ... +60 °C</p> <p>-40 ... +80 °C</p> <p>-40 ... +80 °C</p>
environmental category <ul style="list-style-type: none"> • during operation according to IEC 60721 • during storage according to IEC 60721 • during transport according to IEC 60721 	<p>3K6 (no formation of ice, no condensation, relative humidity 10 ... 95%), 3C3 (no salt mist), 3S2 (sand must not get into the devices), 3M6</p> <p>1K6 (no condensation, relative humidity 10 ... 95%), 1C2 (no salt mist), 1S2 (sand must not get into the devices), 1M4</p> <p>2K2, 2C1, 2S1, 2M2</p>
relative humidity during operation	5 ... 95 %
contact rating of auxiliary contacts according to UL	B300 / R300
Short-circuit protection	
design of the fuse link for short-circuit protection of relay enabling circuits required	gL/gG: 4 A
Safety related data	
safe state	Safety outputs switched off
diagnostics test interval by internal test function maximum	28 800 s
stop category according to IEC 60204-1	0
failure rate [FIT] at rate of recognizable hazardous failures (λ_{dd})	879 FIT
failure rate [FIT] at rate of non-recognizable hazardous failures (λ_{du})	7 FIT
average diagnostic coverage level (DCavg) <ul style="list-style-type: none"> • at single-channel evaluation • at 2-channel evaluation 	<p>90 %</p> <p>99 %</p>
IEC 62061	
Safety Integrity Level (SIL) <ul style="list-style-type: none"> • at single-channel evaluation according to IEC 62061 • at 2-channel evaluation according to IEC 62061 	<p>1</p> <p>3</p>
ISO 13849	
performance level (PL) <ul style="list-style-type: none"> • at single-channel evaluation according to ISO 13849-1 • at 2-channel evaluation according to ISO 13849-1 	<p>d</p> <p>e</p>
category <ul style="list-style-type: none"> • at single-channel evaluation according to ISO 13849-1 • at 2-channel evaluation according to ISO 13849-1 	<p>2</p> <p>4</p>
IEC 61508	
Safety Integrity Level (SIL) <ul style="list-style-type: none"> • at single-channel evaluation according to IEC 61508 • at 2-channel evaluation according to IEC 61508 	<p>1</p> <p>3</p>
safety device type according to IEC 61508-2	Type B
PFDavg with low demand rate <ul style="list-style-type: none"> • at single-channel evaluation according to IEC 61508 • at 2-channel evaluation according to IEC 61508 	<p>0.00065</p> <p>2E-5</p>
Safe failure fraction (SFF)	99 %
hardware fault tolerance <ul style="list-style-type: none"> • at single-channel evaluation according to IEC 61508 • at 2-channel evaluation according to IEC 61508 	<p>0</p> <p>1</p>
T1 value for proof test interval or service life according to IEC 61508	20 a
Electrical Safety	
touch protection against electrical shock	finger-safe
ATEX	
certificate of suitability according to ATEX directive 2014/34/EU	BVS 06 ATEX F001
explosion device group and category according to ATEX directive 2014/34/EU	II (2) G, II (2) D, I (M2)
Galvanic isolation	



(electrically) protective separation according to IEC 60947-1	All circuits in SIMOCODE pro are with protective separation, i.e. they are designed with doubled creepage paths and clearances. NOTICE: The information in the "Protective Separation" test report, No. 2668, must be observed.
design of the electrical isolation	Protective separation in accordance with IEC 60947-1 for all circuits, up to installation altitude of 2000 m



Control circuit/ Control	
type of voltage of the control supply voltage	AC/DC
control supply voltage at AC	
• at 50 Hz rated value	110 ... 240 V
• at 60 Hz rated value	110 ... 240 V
control supply voltage frequency 1	50 ... 60 Hz
control supply voltage frequency	
• 1 rated value	50 Hz
• 2 rated value	60 Hz
control supply voltage at DC rated value	110 ... 240 V
operating range factor control supply voltage rated value at DC	
• initial value	0.85
• full-scale value	1.1
operating range factor control supply voltage rated value at AC at 50 Hz	
• initial value	0.85
• full-scale value	1.1
operating range factor control supply voltage rated value at AC at 60 Hz	
• initial value	0.85
• full-scale value	1.1
inrush current peak	
• at 240 V	24 A
duration of inrush current peak	
• at 240 V	0.5 ms

Approvals Certificates	
------------------------	--

Environment	General Product Approval				
Environmental Confirmations					

General Product Approval	EMV	For use in hazardous locations			
TUEV					

For use in hazardous locations	Functional Safety	Test Certificates	Maritime application		
	Miscellaneous	Type Examination Certificate	Type Test Certificates/Test Report		

Maritime application	other	Industrial Communication		
		Confirmation	Confirmation	

Further information

Information on the packaging

<https://support.industry.siemens.com/cs/ww/en/view/109813875>

Information for data generation and storage

<https://support.industry.siemens.com/cs/ww/en/view/109995012>

Information- and Downloadcenter (Catalogs, Brochures,...)

<https://www.siemens.com/ic10>

Industry Mall (Online ordering system)

<https://mall.industry.siemens.com/mall/en/en/Catalog/product?mlfb=3UF7320-1AU00-0>

Cax online generator

<https://support.automation.siemens.com/WW/CAXorder/default.aspx?lang=en&mlfb=3UF7320-1AU00-0>

Service&Support (Manuals, Certificates, Characteristics, FAQs,...)

<https://support.industry.siemens.com/cs/ww/en/ps/3UF7320-1AU00-0>

Image database (product images, 2D dimension drawings, 3D models, device circuit diagrams, EPLAN macros, ...)

https://www.automation.siemens.com/bilddb/cax_de.aspx?mlfb=3UF7320-1AU00-0&lang=en

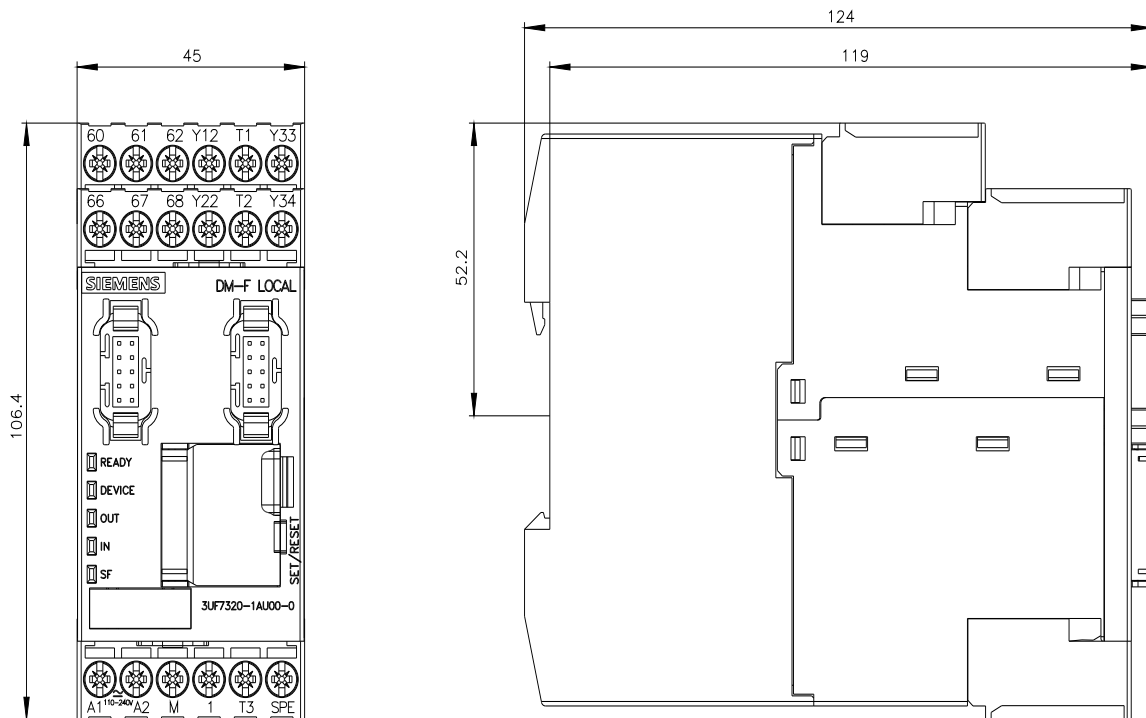

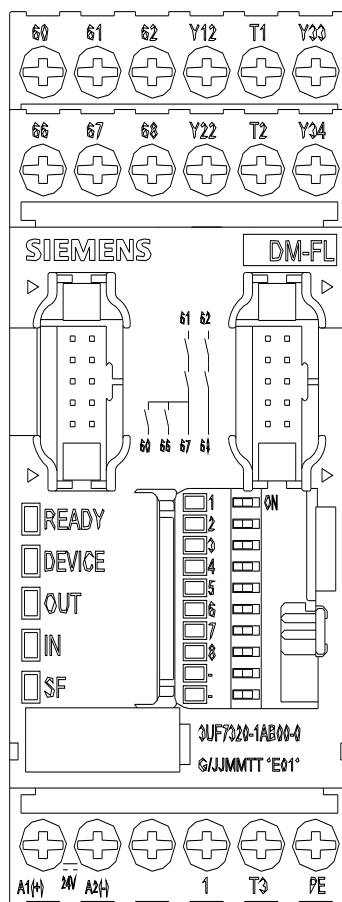
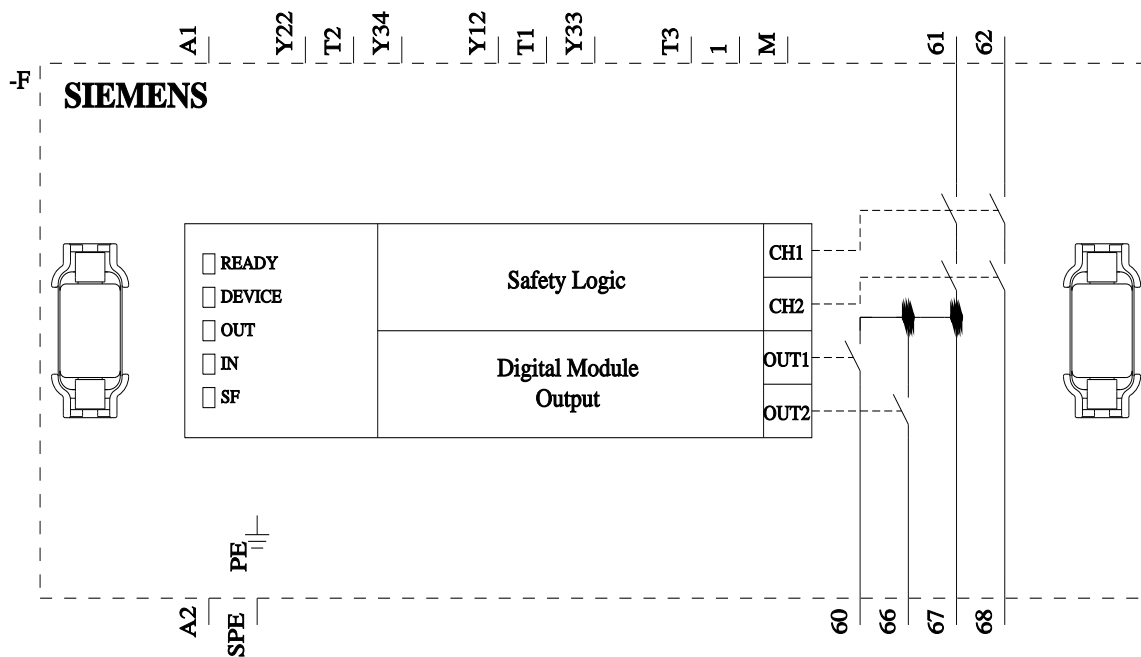

last modified:

4/4/2026