

Product datasheet

Specifications



Preventa safety module - 24 V DC - standard format - < 5 W

TSXPAY262C

⚠ Discontinued on: 31 Dec 2018

⚠ To be end-of-service on: 31 Dec 2026

⚠ Discontinued

EAN Code: 3595863959826

Main

Range of product	Modicon Premium Automation platform
Product or component type	Preventa safety module

Complementary

[Us] rated supply voltage	24 V DC
Supply voltage limits	19.2...30 V
Activation threshold	< 20 V
Short-circuit protection	1 A gG external conforming to IEC 947-5-1 on power supply 4 A gG external conforming to IEC 947-5-1 on safety relay outputs
Isolation voltage	4000 V III 2
Discrete input number	1 for double or single contact selection input conforming to IEC 1131 Type 1 1 for feedback loop input conforming to IEC 1131 Type 1 1 for reset PB input conforming to IEC 1131 Type 1 1 for reset PB monitoring input conforming to IEC 1131 Type 1 12 for emergency stop or limit switch discrete inputs conforming to IEC 1131 Type 1
Discrete input logic	Positive
Inrush current	0.5 A
Isolation between input and earth	500 Vrms 50/60 Hz for 60 s
Maximum power dissipation in W	5 W
Safety outputs	2 NO safety relay AGCDO gold plated volt free output
[Ue] rated operational voltage	17...127 V DC relay output 19...250 V AC relay output
Rated power in VA	120 VA 48 V AC-15 inductive 280 VA 110 V AC-15 inductive 550 VA 220 V AC-15 inductive 60 VA 24 V AC-15 inductive
Rated power in W	60 W 24 V DC-13 inductive 100 ms
[I _{th}] conventional enclosed thermal current	2.5 A
Minimum output current	30 mA
Response time on output	< 12 ms
Isolation between output and earth	300 V conforming to DIN VDE 0110 part 2 1500 Vrms 50/60 Hz for 60 s
Safety acquisition	Monitor external power supply of the module Read the safety outputs control Read feedback loop Read enable inputs Read status of the 24 inputs

Disclaimer: This documentation is not intended as a substitute for and is not to be used for determining suitability or reliability of these products for specific user applications

Local signalling	28 LEDs for diagnostic of safety system
Electrical connection	1 connector removable screw terminal block with 6 pins for connecting the safety output 1 connector SUB-D with 44 pins for connecting the safety system input
Cable cross section	0.2...2.5 mm ² without cable end safety output circuit 1.5 mm ² with cable end safety output circuit
Current consumption	< 150 mA at 5 V DC <= 200 mA at 24 V DC
Module format	Standard
Net weight	0.43 kg

Environment

Ambient air temperature for operation	0...40 °C without fan 0...60 °C with fan module
Ambient air temperature for storage	-25...70 °C
IP degree of protection	IP20 conforming to IEC 60529
Standards	EN 954 machine safety parts of control systems EN/IEC 60204-1 machine electrical equipment EN/IEC 61131-2 specific requirements (PLC) EN/ISO 12100 machine electrical equipment ISO 13850 emergency stop equipment UL 508 specific requirements (PLC) ISO 13849-1 category 4 machine safety parts of control systems IEC 61508 SIL 3 machine safety parts of control systems CSA C22.2 specific requirements (PLC)
Product certifications	CSA UL BG
Protective treatment	Conformal coating Humiseal 1A33

Packing Units

Unit Type of Package 1	PCE
Number of Units in Package 1	1



Environmental Data

Schneider Electric aims to achieve Net Zero status by 2050 through supply chain partnerships, lower impact materials, and circularity via our ongoing “Use Better, Use Longer, Use Again” campaign to extend product lifetimes and recyclability.

[Environmental Data explained >](#)

[How we assess product sustainability >](#)

Use Longer



Lifetime extension

Repair

No

Dimensions Drawings

Standard and Extendable Racks for Modules Mounting

Dimensions of Modules and Racks

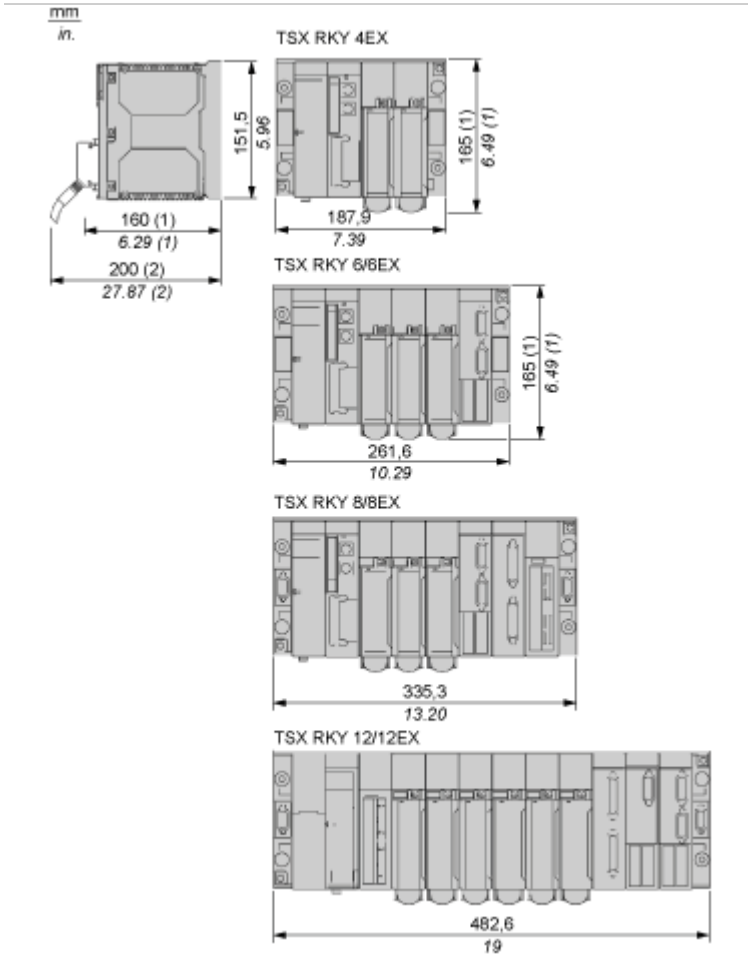

- (1) With screw terminal block modules.
- (2) Maximum depth for all types of modules and their associated connectors.

Connections and Schema

The Safety System

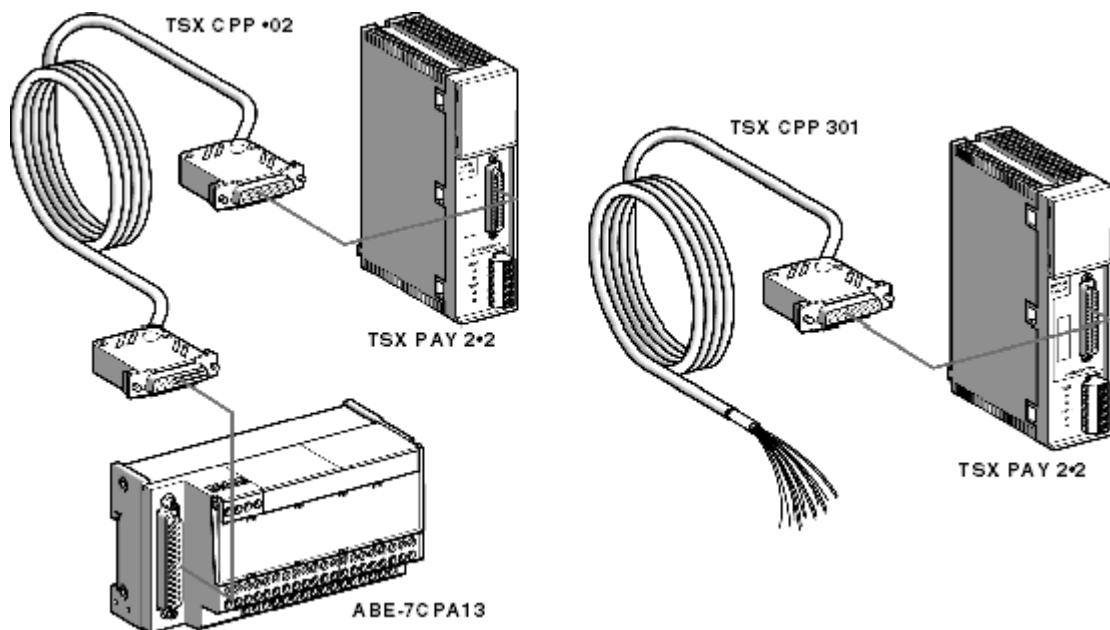

Connection of Emergency Stop Buttons and Safety Switches

Double Contacts (recommended)

Double contact wiring of inputs is suitable for applications requiring category 3 or 4 compliant levels of safety. Short circuits between channels are detected. ES PB or PS short circuits are detected and pinpointed.

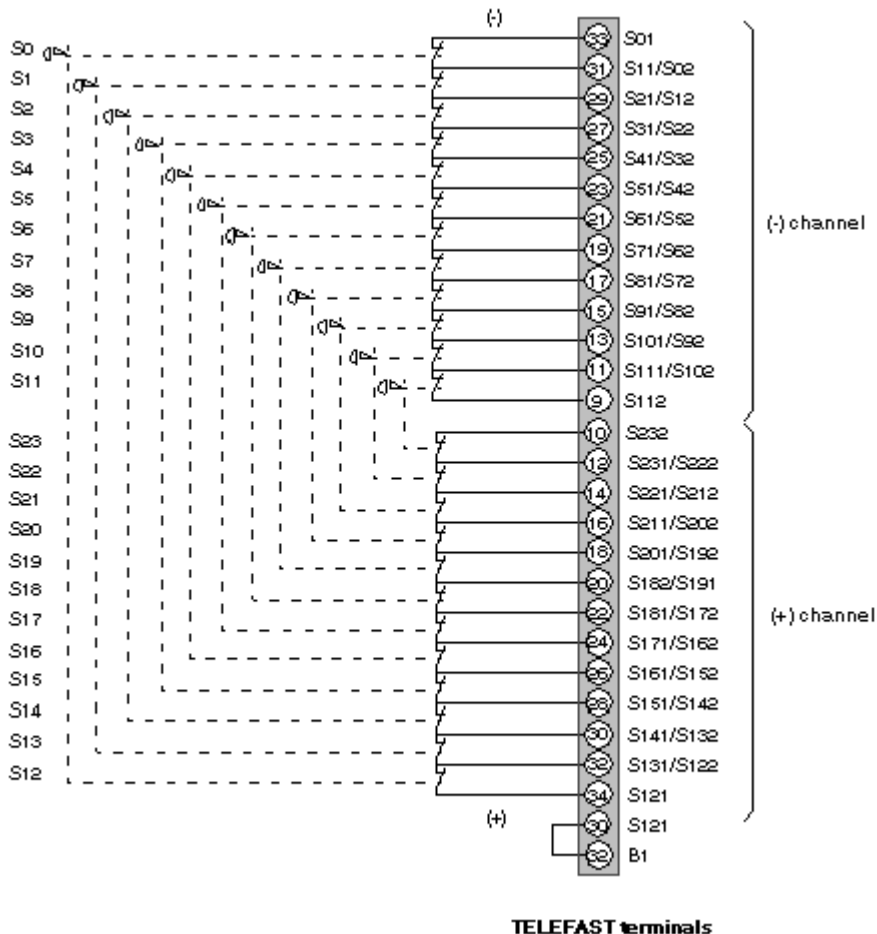

NOTE: If less than 12 double contacts are being used, the input terminals that are not in use must be bridged.

Single Contact

This wiring is not suitable for applications requiring category 3 or 4 compliant levels of safety. Not all errors are detected, nor are ES PB or PS short circuits. Here, pressing this PB will not cause the safety circuits to open (loss of the safety function).

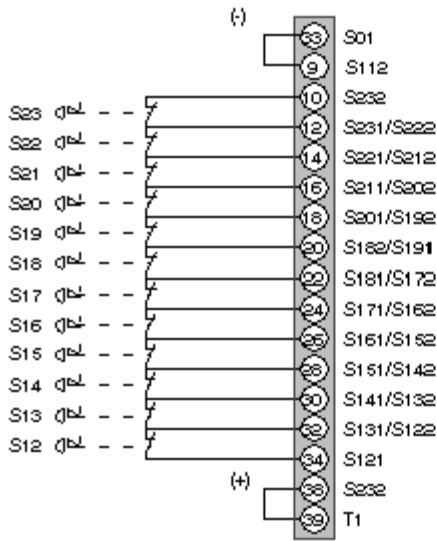

TELEFAST terminals

NOTE: If less than 12 contacts are being used, the input terminals that are not in use must be bridged.

Safety Output Wiring Diagrams

Feedback Loop Connection

The category 4 immediate stop system design requires supply shut-off device redundancy and activation monitoring. Wiring of open contacts (K3, K4) or (K3, K4, K5, K6) allows every activation request to be checked. It is compulsory for the contacts of relays (K3, K4) or (K3, K4, K5, K6) to be mechanically linked. Category 3 wiring means:

- no wiring of auxiliary contacts in the feedback loop (a strap links terminals Y1 and Y2/S33),
- standard switches, with non-guided contacts, are sufficient.

2-switch set-up (category 4):

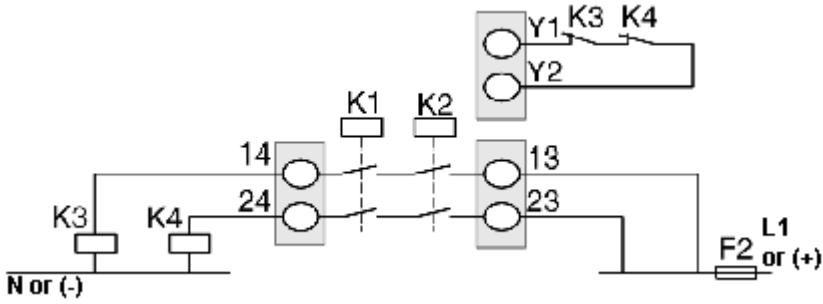

4-switch set-up (category 4):

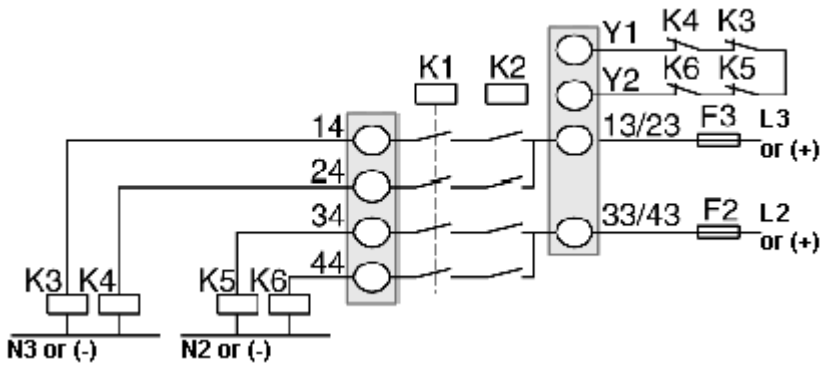

Connection of the Safety System Reactivation Function

Wiring Diagram for Automatic Reactivation

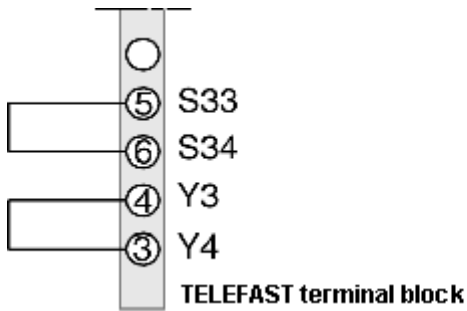

Wiring Diagrams for Manual Reactivation

With Reactivation button monitoring (recommended):

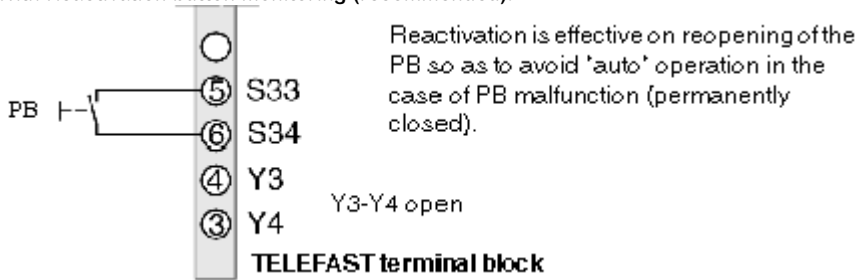

Without Reactivation button monitoring:

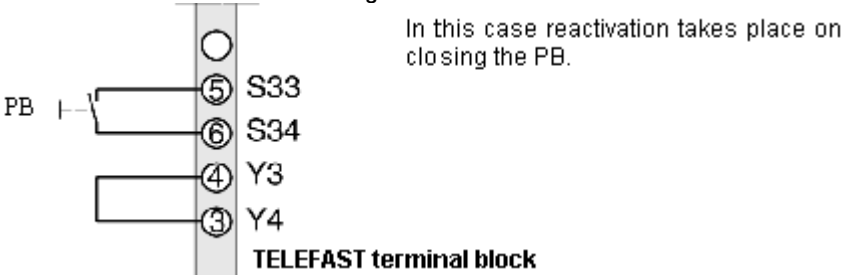

Safety Outputs

Wiring Diagram

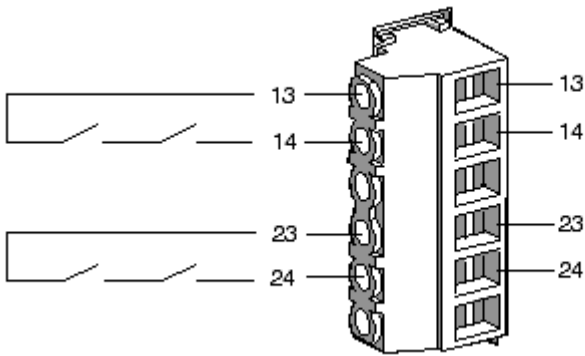

13, 23: Independent supply inputs

14, 24: Safety outputs

NOTE:

Wires cross-section:

- with termination: 2 x 1 mm²/16 AWG or 1 x 1.5 mm²/14 AWG
- without termination: 1 x 2.5 mm²/12 AWG