

Product datasheet

Specifications



servo motor BCH, no oil seal, w key, 20-bit encoder, w brake-straight con

BCH0802O12F1C

! Discontinued on: 28 December 2021

BCH0802O12F1C has not been replaced. Please contact your customer care centre for more information.

! Discontinued

Main

Range compatibility	Lexium 23 Plus
Product or component type	Servo motor
Device short name	BCH

Complementary

Maximum mechanical speed	5000 rpm
[Us] rated supply voltage	220 V
Network number of phases	Single phase
Continuous stall current	5.1 A
Continuous power	0.75 kW
Shaft end	Keyed
Second shaft	Without second shaft end
Shaft diameter	19 mm
Shaft length	37 mm
Key width	6 mm
Feedback type	20 bits incremental encoder
Holding brake	With
Holding torque	2.5 N.m
Mounting support	Asian standard flange
Motor flange size	80 mm
Torque constant	0.47 N.m/A
Back emf constant	17.2 V/krpm at 20 °C
Rotor inertia	1.18 kg.cm ²
Stator resistance	0.84 Ohm at 20 °C
Stator inductance	7.06 mH at 20 °C
Stator electrical time constant	8.37 ms at 20 °C
Maximum radial force Fr	245 N
Maximum axial force Fa	98 N

Brake pull-in power	8.2 W
Type of cooling	Natural convection
Length	178 mm
Number of motor stacks	2
Centring collar diameter	70 mm
Centring collar depth	3 mm
Number of mounting holes	4
Mounting holes diameter	6.6 mm
Circle diameter of the mounting holes	90 mm
Distance shaft shoulder-flange	29.5 mm
Net weight	3.8 kg

Environment

IP degree of protection	IP40
Ambient air temperature for operation	0...40 °C

Packing Units

Unit Type of Package 1	PCE
Number of Units in Package 1	1
Package 1 Weight	4.207 kg
Package 1 Height	16.0 cm
Package 1 width	23.0 cm
Package 1 Length	30.0 cm
Unit Type of Package 2	S06
Number of Units in Package 2	12
Package 2 Weight	63.484 kg
Package 2 Height	73.5 cm
Package 2 width	60.0 cm
Package 2 Length	80.0 cm

Contractual warranty

Warranty	18 months
-----------------	-----------

Dimensions

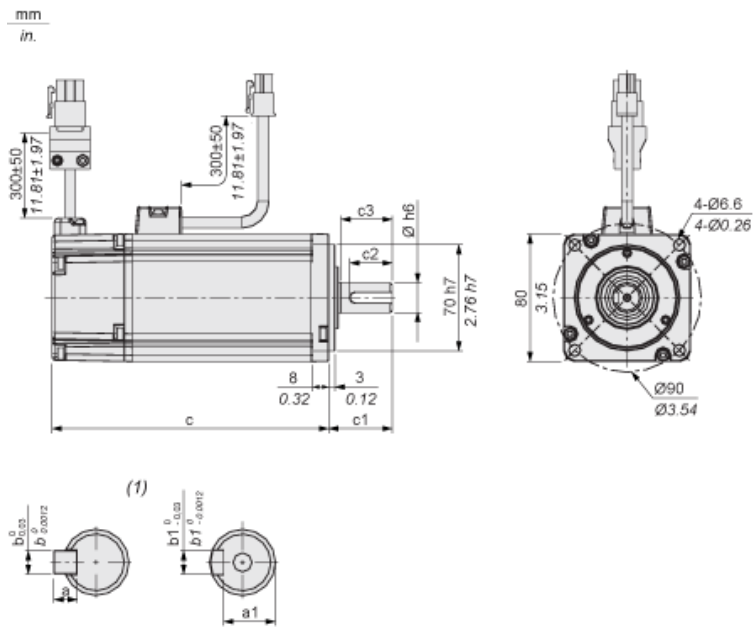

(1) Shaft end, keyed slot (optional)

Dimensions in mm

Ø	a	a1	b	b1	c (without holding brake)	c (with holding brake)	c1	c2	c3
19	6	15.5	6	6	130.7	166.8	35	25	29.5

Dimensions in in.

Ø	a	a1	b	b1	c (without holding brake)	c (with holding brake)	c1	c2	c3
0.75	0.24	0.61	0.24	0.24	5.14	6.57	1.38	0.98	1.16

Torque/Speed Curves with 220 V Single Phase Supply Voltage

Servo Motor with LXM23•U07M3X Servo Drive

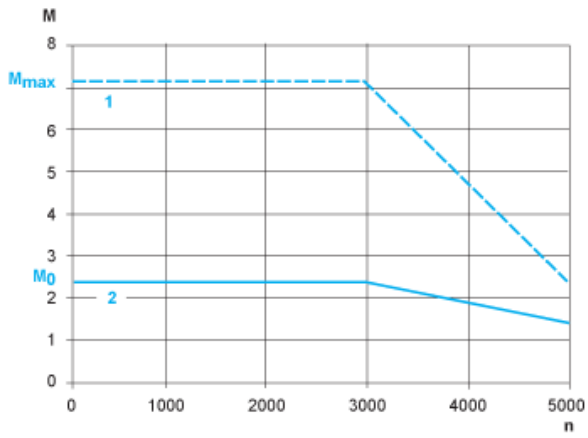

- M :** Torque in Nm
- n :** Speed in rpm
- 1 :** Peak torque
- 2 :** Continuous torque