

Product datasheet

Specifications



Star delta starter, TeSys Deca, 3x3P(3NO), 9A, 230VAC 50/60Hz coil, screw clamp terminal

LC3D09AP7

Main

Range	TeSys TeSys Deca
Product name	TeSys Deca
Product or component type	Star delta starter
Device short name	LC3D
Contactors application	Motor control
Utilisation category	AC-3
Device presentation	Pre-wired
Poles description	3 x 3P
power pole contact composition	3 x 3 NO
[Ue] rated operational voltage	Power circuit: ≤ 690 V AC 25...400 Hz
[Ie] rated operational current	9 A (at ≤ 60 °C) at ≤ 440 V AC AC-3 for power circuit
Motor power kW	4 kW at 220/230 V AC 50/60 Hz 7.5 kW at 380/400 V AC 50/60 Hz 7.5 kW at 415 V AC 50/60 Hz 7.5 kW at 440 V AC 50/60 Hz
Control circuit type	AC at 50/60 Hz
[Uc] control circuit voltage	230 V AC 50/60 Hz
Auxiliary contact composition	1 NC for KM1 star contactor
[Uimp] rated impulse withstand voltage	6 kV conforming to IEC 60947
Overvoltage category	III
[Ui] rated insulation voltage	Power circuit: 690 V conforming to IEC 60947-4-1 Power circuit: 600 V CSA certified Power circuit: 600 V UL certified Signalling circuit: 690 V conforming to IEC 60947-1 Signalling circuit: 600 V CSA certified Signalling circuit: 600 V UL certified
Electrical durability	2 Mcycles 9 A AC-3 at $U_e \leq 440$ V
safety cover	Protective cover
Interlocking type	Mechanical
Mounting support	Plate
Standards	UL 508 EN 60947-5-1 IEC 60947-5-1 EN 60947-4-1 CSA C22.2 No 14 IEC 60947-4-1 IEC 60335-1

Product certifications	CCC CSA DNV GOST LROS (Lloyds register of shipping) UL BV RINA GL
-------------------------------	---

Complementary

Connections - terminals	Power circuit: screw clamp terminals 1 1...4 mm ² - cable stiffness: flexible without cable end Power circuit: screw clamp terminals 2 1...4 mm ² - cable stiffness: flexible without cable end Power circuit: screw clamp terminals 1 1...4 mm ² - cable stiffness: flexible with cable end Power circuit: screw clamp terminals 2 1...2.5 mm ² - cable stiffness: flexible with cable end Power circuit: screw clamp terminals 1 1...4 mm ² - cable stiffness: solid without cable end Power circuit: screw clamp terminals 2 1...4 mm ² - cable stiffness: solid without cable end Control circuit: screw clamp terminals 1 1...4 mm ² - cable stiffness: flexible without cable end Control circuit: screw clamp terminals 2 1...4 mm ² - cable stiffness: flexible without cable end Control circuit: screw clamp terminals 1 1...4 mm ² - cable stiffness: flexible with cable end Control circuit: screw clamp terminals 2 1...2.5 mm ² - cable stiffness: flexible with cable end Control circuit: screw clamp terminals 1 1...4 mm ² - cable stiffness: solid without cable end Control circuit: screw clamp terminals 2 1...4 mm ² - cable stiffness: solid without cable end
Tightening torque	Power circuit: 1.7 N.m - on screw clamp terminals - with screwdriver flat Ø 6 mm Power circuit: 1.7 N.m - on screw clamp terminals - with screwdriver Philips No 2 Control circuit: 1.7 N.m - on screw clamp terminals - with screwdriver flat Ø 6 mm Control circuit: 1.7 N.m - on screw clamp terminals - with screwdriver Philips No 2 Power circuit: 1.7 N.m - on screw clamp terminals - with screwdriver pozidriv No 2 Control circuit: 1.7 N.m - on screw clamp terminals - with screwdriver pozidriv No 2
Mechanical durability	15 Mcycles
Maximum operating rate	30 cyc/h 60 °C
Starting time	30 s
Coil technology	Without built-in suppressor module
Control circuit voltage limits	Drop-out: 0.3...0.6 Uc at 50/60 Hz (at <60 °C) Operational: 0.8...1.1 Uc at 50 Hz (at <60 °C) Operational: 0.85...1.1 Uc at 60 Hz (at <60 °C)
Inrush power in VA	70 VA 60 Hz cos phi 0.75 (at 20 °C) 70 VA 50 Hz cos phi 0.75 (at 20 °C)
Hold-in power consumption in VA	7.5 VA 60 Hz cos phi 0.3 (at 20 °C) 7 VA 50 Hz cos phi 0.3 (at 20 °C)
Heat dissipation	2...3 W at 50/60 Hz
Auxiliary contacts type	Mechanically linked conforming to IEC 60947-5-1 3 x 1 NO + 1 NC Mirror contact conforming to IEC 60947-4-1 3 x 1 NC
Signalling circuit frequency	25...400 Hz
Minimum switching current	5 mA for signalling circuit
minimum switching voltage	17 V for signalling circuit
Non-overlap time	1.5 ms on de-energisation between NC and NO contact 1.5 ms on energisation between NC and NO contact
Width	143 mm

Height	124 mm
Depth	143 mm
Net weight	1.53 kg

Environment

Insulation resistance	> 10 MOhm for signalling circuit
IP degree of protection	IP20 front face conforming to IEC 60529
Climatic withstand	conforming to IACS E10 conforming to IEC 60947-1 Annex Q category D
Protective treatment	TH conforming to IEC 60068-2-30
Pollution degree	3
Ambient air temperature for storage	-60...80 °C
Ambient air temperature for operation	-40...70 °C at U _c
Operating altitude	3000 m without derating
Fire resistance	850 °C conforming to IEC 60695-2-1
Flame retardance	V1 conforming to UL 94
Mechanical robustness	Vibrations contactor open: 2 Gn, 5...300 Hz Vibrations contactor closed: 4 Gn, 5...300 Hz Shocks contactor open: 10 Gn for 11 ms Shocks contactor closed: 15 Gn for 11 ms

Packing Units

Unit Type of Package 1	PCE
Number of Units in Package 1	1
Package 1 Height	17.700 cm
Package 1 Width	16.000 cm
Package 1 Length	23.200 cm
Package 1 Weight	1.612 kg
Unit Type of Package 2	P06
Number of Units in Package 2	27
Package 2 Height	75.000 cm
Package 2 Width	60.000 cm
Package 2 Length	80.000 cm
Package 2 Weight	55.470 kg

Contractual warranty

Warranty (in months)	18
----------------------	----



Environmental Data

Schneider Electric aims to achieve Net Zero status by 2050 through supply chain partnerships, lower impact materials, and circularity via our ongoing “Use Better, Use Longer, Use Again” campaign to extend product lifetimes and recyclability.

[Environmental Data explained >](#)

[How we assess product sustainability >](#)



Environmental footprint

Total lifecycle Carbon footprint	60 kg CO2 eq.
Carbon footprint of the manufacturing phase [A1 to A3]	9 kg CO2 eq.
Carbon footprint of the distribution phase [A4]	0.7 kg CO2 eq.
Carbon footprint of the installation phase [A5]	0.1 kg CO2 eq.
Carbon footprint of the use phase [B2, B3, B4, B6]	47 kg CO2 eq.
Carbon footprint of the end-of-life phase [C1 to C4]	4 kg CO2 eq.
Environmental Disclosure	Product Environmental Profile

Use Better



Materials and Substances

Packaging made with recycled cardboard	Yes
Packaging without single use plastic	Yes
EU RoHS Directive	Compliant
REACH Regulation	Free of Substances of Very High Concern above the threshold
PVC free	Yes

Use Longer



Lifetime extension

Repair	No
--------	----

Use Again



Repack and remanufacture

Recyclability potential, in %	66
End of life manual availability	End of Life Information
Take-back	Nej
WEEE Label	 The product must be disposed on European Union markets following specific waste collection and never end up in rubbish bins

Dimensions Drawings

Dimensions

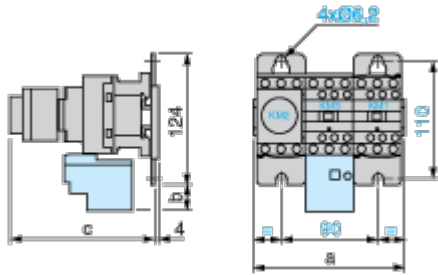

LC3		D09A	D12A	D18A	D32A
a		143	143	144	165
b		26.5	26.5	26.5	32.5
c	with LAD S	139	139	139	145
	with LAD S and sealing cover	143	143	143	149

Connections and Schema

Wiring

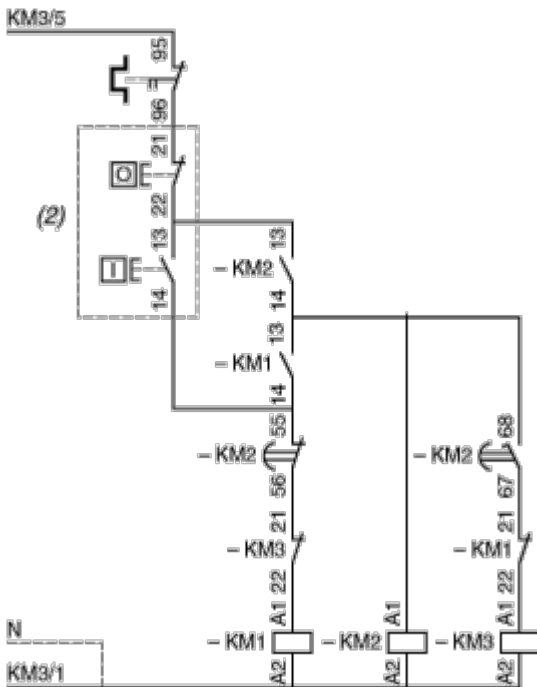
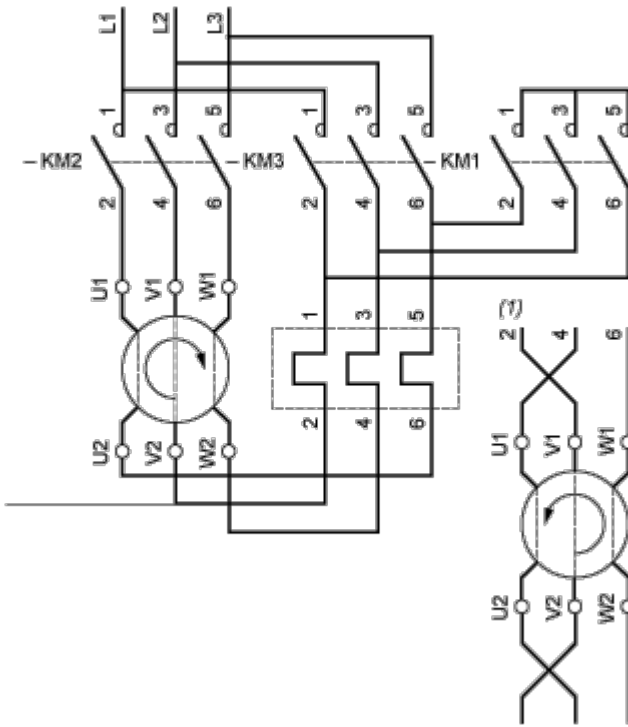

- (1) Recommended cabling for reversal of motor rotation (standard motor, viewed from shaft end).
- (2) Remote control.

NOTE: LC3 D09A to D18A: Mechanical interlock between KM3 and KM1.

