



SIRIUS motor starter M200D technology module direct-on-line starter electronic switching AC-3, 5.5 kW / 400 V 1.5 A...12.00 A electronic overload protection thermistor: thermoclick / PTC with brake contact 180 V DC 4 DI / 2 DO Han Q4/2 - Han Q8/0 via communications module 3RK1305\* can be used on PROFIBUS or PROFINET

<b>product brand name</b>	SIRIUS
<b>product designation</b>	Motor starters
<b>design of the product</b>	direct starter
<b>product type designation</b>	M200D
<b>product function</b>	
• on-site operation	No
• control circuit interface to parallel wiring	No
<b>insulation voltage rated value</b>	500 V
<b>degree of pollution</b>	3
<b>surge voltage resistance rated value</b>	6 000 V
<b>maximum permissible voltage for protective separation</b>	
• between main and auxiliary circuit	400 V
• between control and auxiliary circuit	24 V
<b>shock resistance</b>	12 g / 11 ms
<b>vibration resistance</b>	7 mm / 2 g
<b>type of coordination</b>	1
<b>Substance Prohibitance (day/month/year)</b>	07/01/2006
<b>SVHC substance name</b>	Lead CAS-No. 7439-92-1 Lead monoxide (lead oxide) CAS-No. 1317-36-8 2-methyl-1-(4-methylthiophenyl)-2-morpholinopropan-1-one CAS-No. 71868-10-5 Melamine CAS-No. 108-78-1
<b>Net Weight</b>	4.023 kg
<b>product function</b>	
• direct start	Yes
• reverse starting	No
<b>product component motor brake output</b>	Yes
<b>product feature</b>	
• brake control with 230 V AC	No
• brake control with 400 V AC	No
• brake control with 24 V DC	No
• brake control with 180 V DC	Yes
• brake control with 500 V DC	No
<b>product extension braking module for brake control</b>	No
<b>product function short circuit protection</b>	Yes
<b>design of short-circuit protection</b>	circuit-breakers
<b>maximum short-circuit current breaking capacity (Icu)</b>	
• at 400 V rated value	50 000 A
• at 500 V rated value	20 000 A
EMC emitted interference according to IEC 60947-1	CISPR11, ambience A (group 2)

EMC immunity according to IEC 60947-1	corresponds to degree of severity 3, ambience A (industrial sector)
<b>conducted interference</b>	
<ul style="list-style-type: none"> <li>• due to burst according to IEC 61000-4-4</li> </ul>	2 kV network connection / 1 kV control connection
<ul style="list-style-type: none"> <li>• due to conductor-earth surge according to IEC 61000-4-5</li> </ul>	2 kV
<ul style="list-style-type: none"> <li>• due to conductor-conductor surge according to IEC 61000-4-5</li> </ul>	1 kV
<b>Safety related data</b>	
<b>proportion of dangerous failures</b>	
<ul style="list-style-type: none"> <li>• with low demand rate according to SN 31920</li> </ul>	50 %
<ul style="list-style-type: none"> <li>• with high demand rate according to SN 31920</li> </ul>	75 %
<b>B10 value with high demand rate according to SN 31920</b>	1 000 000
<b>failure rate [FIT] with low demand rate according to SN 31920</b>	100 FIT
<b>IEC 61508</b>	
T1 value for proof test interval or service life according to IEC 61508	20 a
<b>Electrical Safety</b>	
<b>touch protection against electrical shock</b>	finger-safe
<b>Main circuit</b>	
<b>number of poles for main current circuit</b>	3
<b>design of the switching contact</b>	solid-state / thyristor / 2 phases
<b>adjustable current response value current of the current-dependent overload release</b>	1.5 ... 12 A
<b>type of the motor protection</b>	full motor protection
operating voltage rated value	200 ... 440 V
<b>operational current</b>	
<ul style="list-style-type: none"> <li>• at AC at 400 V rated value</li> </ul>	12 A
<ul style="list-style-type: none"> <li>• at AC-3 at 400 V rated value</li> </ul>	12 A
<b>operating power</b>	
<ul style="list-style-type: none"> <li>• at AC-3 <ul style="list-style-type: none"> <li>— at 400 V rated value</li> <li>— at 500 V rated value</li> </ul> </li> </ul>	5.5 kW 5 500 W
<ul style="list-style-type: none"> <li>• at AC-3e <ul style="list-style-type: none"> <li>— at 400 V rated value</li> <li>— at 500 V rated value</li> </ul> </li> </ul>	6 kW 5.5 kW
<b>product function</b>	
<ul style="list-style-type: none"> <li>• digital inputs parameterizable</li> </ul>	Yes
<ul style="list-style-type: none"> <li>• digital outputs parameterizable</li> </ul>	Yes
<b>number of digital inputs</b>	4
<b>number of sockets</b>	
<ul style="list-style-type: none"> <li>• for digital output signals</li> </ul>	2
<ul style="list-style-type: none"> <li>• for digital input signals</li> </ul>	4
<b>number of digital outputs</b>	2
<b>Supply voltage</b>	
<b>type of voltage of the supply voltage</b>	DC
<b>Control circuit/ Control</b>	
<b>type of voltage of the control supply voltage</b>	DC
<b>control supply voltage 1 at DC rated value</b>	20.4 ... 28.8 V
<b>control supply voltage 1 at DC</b>	20.4 ... 28.8 V
<b>control current at DC</b>	
<ul style="list-style-type: none"> <li>• in standby mode of operation</li> </ul>	100 mA
<ul style="list-style-type: none"> <li>• during operation</li> </ul>	0.6 A
<b>power loss [W] in auxiliary and control circuit</b>	
<ul style="list-style-type: none"> <li>• in switching state OFF with bypass circuit</li> </ul>	2.7936 W
<ul style="list-style-type: none"> <li>• in switching state ON with bypass circuit</li> </ul>	5.5296 W
<b>Response times</b>	
<b>ON-delay time</b>	25 ms
<b>OFF-delay time</b>	35 ms
<b>mounting position</b>	vertical, horizontal, flat
<b>mounting position recommended</b>	horizontal

<b>fastening method</b>	screw fixing
<b>height</b>	215 mm
<b>width</b>	294 mm
<b>depth</b>	148 mm
<b>Ambient conditions</b>	
installation altitude at height above sea level maximum	2 000 m
<b>ambient temperature</b>	
• during operation	-25 ... +55 °C
• during storage	-40 ... +70 °C
• during transport	-40 ... +70 °C
relative humidity during operation	10 ... 95 %
<b>protocol is supported</b>	
• PROFIBUS DP protocol	No
• PROFINET protocol	No
<b>design of the interface</b>	
• AS-Interface protocol	No
• PROFINET protocol	No
• PROFIBUS DP protocol	No
<b>product function bus communication</b>	Yes
protocol is supported AS-Interface protocol	No
product function control circuit interface with IO link	No
<b>type of electrical connection</b>	
• for main current circuit	plug according to ISO 23570, HAN Q4/2 connector
• for auxiliary and control circuit	
<b>type of electrical connection</b>	
• 1 for digital input signals	M12 socket
• 1 for digital output signals	M12 socket
• 2 for digital input signals	M12 socket
• 3 for digital input signals	M12 socket
• 4 for digital input signals	M12 socket
full-load current (FLA) for 3-phase AC motor at 480 V rated value	11 A
<b>yielded mechanical performance [hp]</b>	
• for 3-phase AC motor	
— at 220/230 V rated value	3 hp
— at 460/480 V rated value	7.5 hp
operating voltage at AC at 60 Hz according to CSA and UL rated value	480 V

#### Approvals Certificates

General Product Approval

EMV



Test Certificates

other

Environment

Industrial Communication

[Type Test Certificates/Test Report](#)



[Confirmation](#)

[Environmental Confirmations](#)



#### Further information

Information on the packaging

<https://support.industry.siemens.com/cs/ww/en/view/109813875>

Information for data generation and storage

<https://support.industry.siemens.com/cs/ww/en/view/109995012>

Information- and Downloadcenter (Catalogs, Brochures,...)

<https://www.siemens.com/ic10>

Industry Mall (Online ordering system)

<https://mall.industry.siemens.com/mall/en/en/Catalog/product?mlfb=3RK1395-6LS71-0AD5>

Cax online generator

<https://support.automation.siemens.com/WW/CAXorder/default.aspx?lang=en&mlfb=3RK1395-6LS71-0AD5>

Service&Support (Manuals, Certificates, Characteristics, FAQs,...)

<https://support.industry.siemens.com/cs/ww/en/ps/3RK1395-6LS71-0AD5>

Image database (product images, 2D dimension drawings, 3D models, device circuit diagrams, EPLAN macros, ...)

[https://www.automation.siemens.com/bilddb/cax\\_de.aspx?mlfb=3RK1395-6LS71-0AD5&lang=en](https://www.automation.siemens.com/bilddb/cax_de.aspx?mlfb=3RK1395-6LS71-0AD5&lang=en)

Characteristic curves

[https://curves.simaris.siemens.com/curves/<mmp\\_prod\\_noCOMP='HAUPT'></mmp\\_prod\\_no>](https://curves.simaris.siemens.com/curves/<mmp_prod_noCOMP='HAUPT'></mmp_prod_no>)

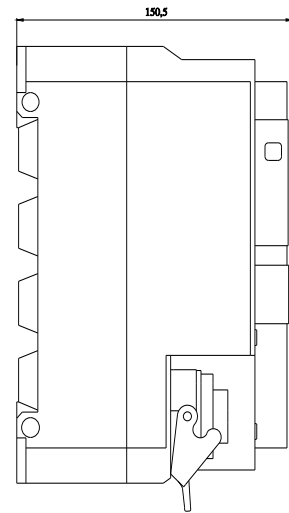
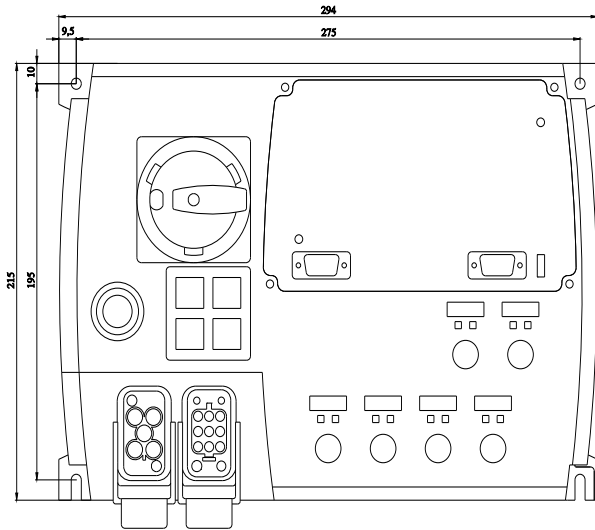

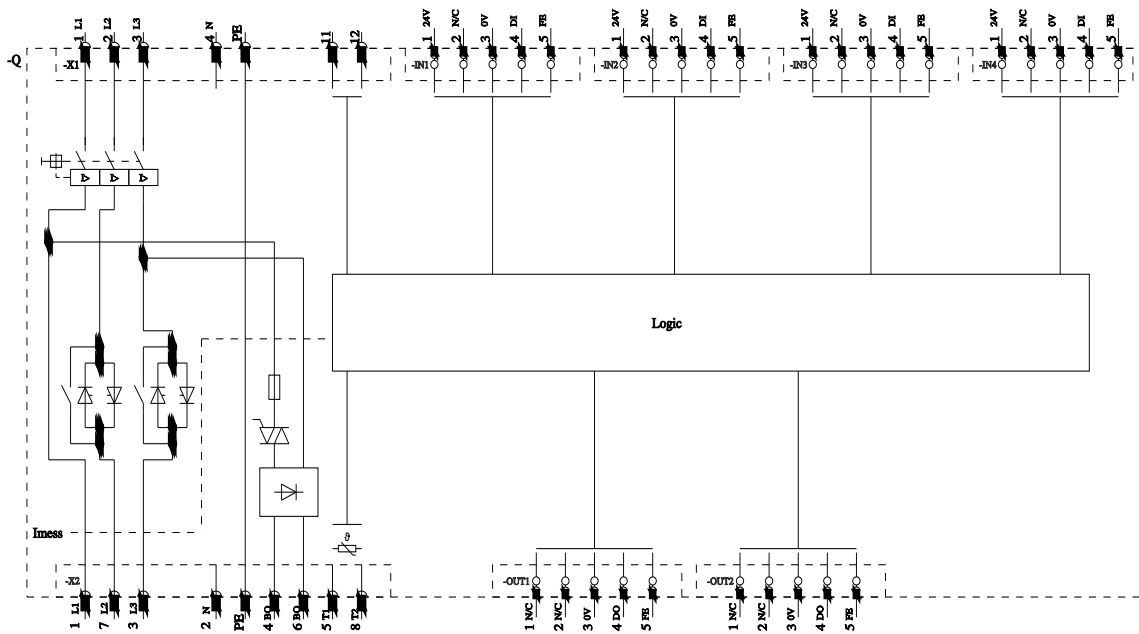

last modified:

4/4/2026 