

Product datasheet

Specifications



Star delta starter, TeSys Deca, 3 x 3P (3 NO) - 80 A - 400 V AC coil

LC3D80V7

⚠ Discontinued on: 1 Nov 2020

⚠ Discontinued

Main

Range	TeSys
Product name	TeSys D
Product or component type	Star delta starter
Device short name	LC3D
Contactors application	Motor control
Utilisation category	AC-3
Device presentation	Pre-wired
Poles description	3 x 3P
power pole contact composition	3 x 3 NO
[Ue] rated operational voltage	Power circuit: ≤ 690 V AC 25...400 Hz
[Ie] rated operational current	80 A (at ≤ 60 °C) at ≤ 440 V AC AC-3 for power circuit
Motor power kW	37 kW at 220/230 V AC 50/60 Hz 75 kW at 380/400 V AC 50/60 Hz 75 kW at 415 V AC 50/60 Hz 75 kW at 440 V AC 50/60 Hz
Control circuit type	AC at 50/60 Hz
[Uc] control circuit voltage	400 V AC 50/60 Hz
Auxiliary contact composition	1 NC for KM2 line contactor 1 NO for KM3 delta contactor
[Uimp] rated impulse withstand voltage	8 kV conforming to IEC 60947
Overvoltage category	III
[Ui] rated insulation voltage	Power circuit: 600 V CSA certified Power circuit: 600 V UL certified Signalling circuit: 600 V CSA certified Signalling circuit: 600 V UL certified Power circuit: 1000 V conforming to IEC 60947-4-1 Signalling circuit: 1000 V conforming to IEC 60947-1
Electrical durability	10 Mcycles 80 A AC-3 at $U_e \leq 440$ V
Mounting support	Plate
Standards	CSA C22.2 No 14 UL 508 IEC 60947-5-1 IEC 60947-4-1 EN 60947-5-1 EN 60947-4-1

Product certifications	<ul style="list-style-type: none"> UL GL DNV BV GOST CCC LROS (Lloyds register of shipping) RINA CSA
-------------------------------	---------------------------------------------------------------------------------------------------------------------------------------------------------------------------------------------

Complementary

Connections - terminals	<p>Control circuit: screw clamp terminals 1 1...4 mm² - cable stiffness: flexible without cable end</p> <p>Control circuit: screw clamp terminals 2 1...4 mm² - cable stiffness: flexible without cable end</p> <p>Control circuit: screw clamp terminals 2 1...2.5 mm² - cable stiffness: flexible with cable end</p> <p>Control circuit: screw clamp terminals 1 1...4 mm² - cable stiffness: solid without cable end</p> <p>Control circuit: screw clamp terminals 2 1...4 mm² - cable stiffness: solid without cable end</p> <p>Power circuit: screw clamp terminals 1 4...50 mm² - cable stiffness: flexible without cable end</p> <p>Power circuit: screw clamp terminals 2 4...25 mm² - cable stiffness: flexible without cable end</p> <p>Power circuit: screw clamp terminals 1 4...50 mm² - cable stiffness: flexible with cable end</p> <p>Power circuit: screw clamp terminals 2 4...16 mm² - cable stiffness: flexible with cable end</p> <p>Power circuit: screw clamp terminals 1 4...50 mm² - cable stiffness: solid without cable end</p> <p>Power circuit: screw clamp terminals 2 4...25 mm² - cable stiffness: solid without cable end</p> <p>Control circuit: screw clamp terminals 1 1...2.5 mm² - cable stiffness: flexible with cable end</p>
Tightening torque	<p>Control circuit: 1.2 N.m - on screw clamp terminals - with screwdriver flat Ø 6 mm</p> <p>Control circuit: 1.2 N.m - on screw clamp terminals - with screwdriver Phillips No 2</p> <p>Power circuit: 12 N.m - on screw clamp terminals - with screwdriver flat Ø 6...8 mm</p>
Mechanical durability	4 Mcycles
Maximum operating rate	30 cyc/h 60 °C
Starting time	30 s
Coil technology	Without built-in suppressor module
Control circuit voltage limits	<p>Drop-out: 0.3...0.6 Uc at 50/60 Hz (at <55 °C)</p> <p>Operational: 0.8...1.1 Uc at 50 Hz (at <55 °C)</p> <p>Operational: 0.85...1.1 Uc at 60 Hz (at <55 °C)</p>
Inrush power in VA	<p>140 VA 60 Hz cos phi 0.75 (at 20 °C)</p> <p>160 VA 50 Hz cos phi 0.75 (at 20 °C)</p>
Hold-in power consumption in VA	<p>13 VA 60 Hz cos phi 0.3 (at 20 °C)</p> <p>15 VA 50 Hz cos phi 0.3 (at 20 °C)</p>
Heat dissipation	4...5 W at 50/60 Hz
Auxiliary contacts type	<p>Mechanically linked conforming to IEC 60947-5-1 3 x 1 NO + 1 NC</p> <p>Mirror contact conforming to IEC 60947-4-1 3 x 1 NC</p>
Signalling circuit frequency	25...400 Hz
Minimum switching current	5 mA for signalling circuit
minimum switching voltage	17 V for signalling circuit
Non-overlap time	<p>1.5 ms on de-energisation between NC and NO contact</p> <p>1.5 ms on energisation between NC and NO contact</p>
Width	311 mm
Height	143 mm
Depth	183 mm

Net weight	5.2 kg
------------	--------

Environment

Insulation resistance	> 10 MOhm for signalling circuit
-----------------------	----------------------------------

IP degree of protection	IP20 front face conforming to IEC 60529
-------------------------	-----------------------------------------

Protective treatment	TH conforming to IEC 60068-2-30
----------------------	---------------------------------

Pollution degree	3
------------------	---

Ambient air temperature for storage	-60...80 °C
-------------------------------------	-------------

Ambient air temperature for operation	-40...60 °C 60...70 °C with derating
---------------------------------------	-----------------------------------------

Operating altitude	3000 m
--------------------	--------

Fire resistance	850 °C conforming to IEC 60695-2-1
-----------------	------------------------------------

Flame retardance	V1 conforming to UL 94
------------------	------------------------

Mechanical robustness	Vibrations contactor open: 2 Gn, 5...300 Hz Shocks contactor open: 8 Gn for 11 ms Vibrations contactor closed: 3 Gn, 5...300 Hz Shocks contactor closed: 10 Gn for 11 ms
-----------------------	-----------------------------------------------------------------------------------------------------------------------------------------------------------------------------------

Packing Units

Unit Type of Package 1	PCE
------------------------	-----

Number of Units in Package 1	1
------------------------------	---

Package 1 Height	28.5 cm
------------------	---------

Package 1 Width	23 cm
-----------------	-------

Package 1 Length	41 cm
------------------	-------

Package 1 Weight	6.285 kg
------------------	----------

Contractual warranty

Warranty (in months)	18
----------------------	----



Environmental Data

Schneider Electric aims to achieve Net Zero status by 2050 through supply chain partnerships, lower impact materials, and circularity via our ongoing “Use Better, Use Longer, Use Again” campaign to extend product lifetimes and recyclability.

[Environmental Data explained >](#)

[How we assess product sustainability >](#)

Use Better



Materials and Substances

EU RoHS Directive

[Compliant](#)

PVC free

Yes

Use Longer



Lifetime extension

Repair

No

Use Again



Repack and remanufacture

WEEE Label



The product must be disposed on European Union markets following specific waste collection and never end up in rubbish bins

Dimensions Drawings

Dimensions

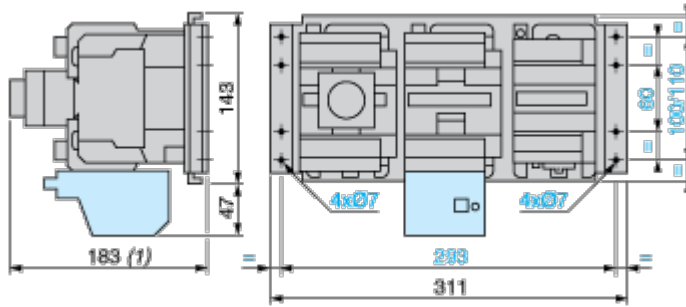

(1) +4 mm with sealing cover

Connections and Schema

Wiring

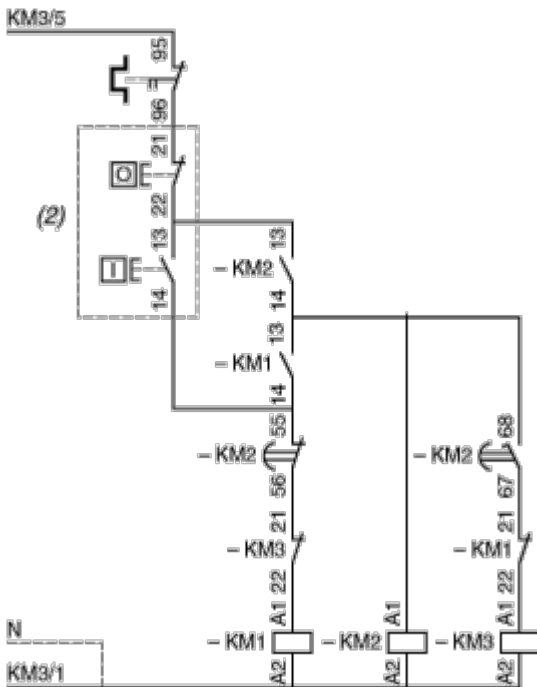
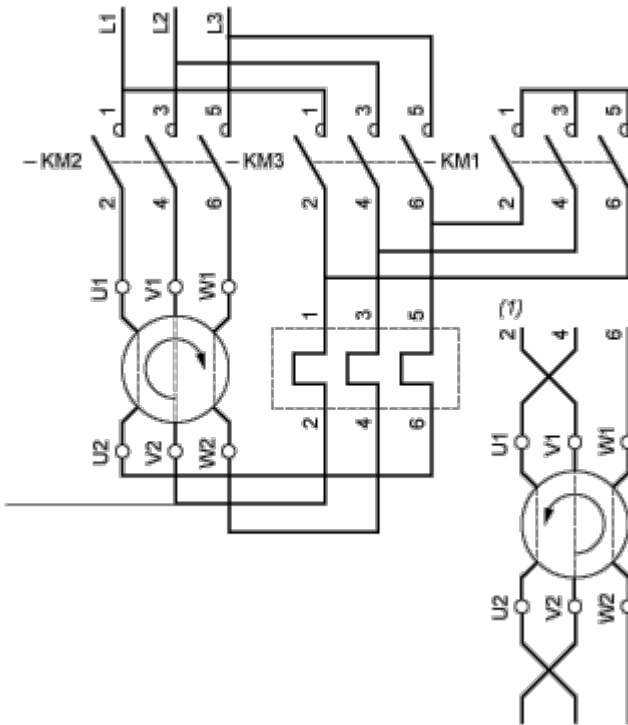

- (1) Recommended cabling for reversal of motor rotation (standard motor, viewed from shaft end).
- (2) Remote control.

NOTE: LC3 D09A to D18A: Mechanical interlock between KM3 and KM1.

