

Product data sheet

Specifications



TeSys Deca - star delta starter - 3 x 3P (3 NO) - 80 A - 24 V AC coil

LC3D80B7

⚠ Discontinued on: Aug 15, 2025

⚠ Discontinued

Main

Range	TeSys
Product name	TeSys Deca
Product or Component Type	Star delta starter
Device short name	LC3D
Contact application	Motor control
Utilisation category	AC-3
Device presentation	Pre-wired
Poles description	3 x 3P
power pole contact composition	3 x 3 NO
[Ue] rated operational voltage	Power circuit ≤ 690 V AC 25...400 Hz
[Ie] rated operational current	80 A (at ≤ 140 °F (60 °C)) at ≤ 440 V AC AC-3 for power circuit
Motor power kW	37 kW 220/230 V AC 50/60 Hz 75 kW 380/400 V AC 50/60 Hz 75 kW 415 V AC 50/60 Hz 75 kW 440 V AC 50/60 Hz
Control circuit type	AC 50/60 Hz
[Uc] control circuit voltage	24 V AC 50/60 Hz
Auxiliary contact composition	1 NC KM2 line contactor 1 NO KM3 delta contactor
[Uimp] rated impulse withstand voltage	8 kV IEC 60947
Overvoltage category	III
[Ui] rated insulation voltage	Power circuit 600 V CSA Power circuit 600 V UL Signalling circuit 600 V CSA Signalling circuit 600 V UL Power circuit 1000 V IEC 60947-4-1 Signalling circuit 1000 V IEC 60947-1
Electrical durability	10 Mcycles 80 A AC-3 ≤ 440 V
Mounting Support	Plate
Standards	EN 60947-4-1 CSA C22.2 No 14 EN 60947-5-1 IEC 60947-4-1 UL 508 IEC 60947-5-1

Price is "List Price" and may be subject to a trade discount – check with your local distributor or retailer for actual price.

Product Certifications	GL
	CCC
	UL
	GOST
	LROS (Lloyds register of shipping)
	CSA
	DNV
	RINA
	BV

Complementary

Connections - terminals	Control circuit: screw clamp terminals 1 0.002...0.006 in ² (1...4 mm ²) - cable stiffness: flexible without cable end Control circuit: screw clamp terminals 2 0.002...0.006 in ² (1...4 mm ²) - cable stiffness: flexible without cable end Control circuit: screw clamp terminals 2 0.002...0.004 in ² (1...2.5 mm ²) - cable stiffness: flexible with cable end Control circuit: screw clamp terminals 1 0.002...0.006 in ² (1...4 mm ²) - cable stiffness: solid without cable end Control circuit: screw clamp terminals 2 0.002...0.006 in ² (1...4 mm ²) - cable stiffness: solid without cable end Power circuit: screw clamp terminals 1 0.006...0.08 in ² (4...50 mm ²) - cable stiffness: flexible without cable end Power circuit: screw clamp terminals 2 0.006...0.04 in ² (4...25 mm ²) - cable stiffness: flexible without cable end Power circuit: screw clamp terminals 1 0.006...0.08 in ² (4...50 mm ²) - cable stiffness: flexible with cable end Power circuit: screw clamp terminals 2 0.006...0.02 in ² (4...16 mm ²) - cable stiffness: flexible with cable end Power circuit: screw clamp terminals 1 0.006...0.08 in ² (4...50 mm ²) - cable stiffness: solid without cable end Power circuit: screw clamp terminals 2 0.006...0.04 in ² (4...25 mm ²) - cable stiffness: solid without cable end Control circuit: screw clamp terminals 1 0.002...0.004 in ² (1...2.5 mm ²) - cable stiffness: flexible with cable end
Tightening torque	Control circuit 10.6 lbf.in (1.2 N.m) screw clamp terminals flat Ø 6 mm Control circuit 10.6 lbf.in (1.2 N.m) screw clamp terminals Philips No 2 Power circuit 106.2 lbf.in (12 N.m) screw clamp terminals flat Ø 6...8 mm
Mechanical durability	4 Mcycles
Maximum operating rate	30 cyc/h 140 °F (60 °C)
Starting time	30 s
Coil technology	Without built-in suppressor module
Control circuit voltage limits	Drop-out: 0.3...0.6 Uc at 50/60 Hz (at <131 °F (55 °C)) Operational: 0.8...1.1 Uc at 50 Hz (at <131 °F (55 °C)) Operational: 0.85...1.1 Uc at 60 Hz (at <131 °F (55 °C))
Inrush power in VA	140 VA 60 Hz cos phi 0.75 (at 68 °F (20 °C)) 160 VA 50 Hz cos phi 0.75 (at 68 °F (20 °C))
Hold-in power consumption in VA	13 VA 60 Hz cos phi 0.3 (at 68 °F (20 °C)) 15 VA 50 Hz cos phi 0.3 (at 68 °F (20 °C))
Heat dissipation	4...5 W 50/60 Hz
Auxiliary contacts type	Mechanically linked IEC 60947-5-1 3 x 1 NO + 1 NC Mirror contact IEC 60947-4-1 3 x 1 NC
Signalling circuit frequency	25...400 Hz
Minimum switching current	5 mA for signalling circuit
minimum switching voltage	17 V signalling circuit
Non-overlap time	1.5 ms on de-energisation between NC and NO contact 1.5 ms on energisation between NC and NO contact
Width	12.2 in (311 mm)
Height	5.6 in (143 mm)
Depth	7.2 in (183 mm)

Net Weight	11.5 lb(US) (5.2 kg)
------------	----------------------

Environment

Insulation resistance	> 10 MOhm for signalling circuit
IP degree of protection	IP20 front face IEC 60529
Protective treatment	TH IEC 60068-2-30
Pollution degree	3
Ambient Air Temperature for Storage	-76...176 °F (-60...80 °C)
Ambient air temperature for operation	-40...140 °F (-40...60 °C) 140...158 °F (60...70 °C) with derating
Operating altitude	9842.52 ft (3000 m)
Fire resistance	1562 °F (850 °C) IEC 60695-2-1
Flame retardance	V1 conforming to UL 94
Mechanical robustness	Vibrations contactor open2 Gn, 5...300 Hz Shocks contactor open8 Gn for 11 ms Vibrations contactor closed3 Gn, 5...300 Hz Shocks contactor closed10 Gn for 11 ms

Ordering and shipping details

Category	18401-WORLD SERVICE PARTS(CTR ACCESS)
Discount Schedule	CP10
GTIN	3389110094206
Returnability	No

Packing Units

Unit Type of Package 1	PCE
Nbr. of units in pkg.	1
Package 1 Height	10.630 in (27.000 cm)
Package 1 Width	10.236 in (26.000 cm)
Package 1 Length	14.961 in (38.000 cm)
Package weight(Lbs)	14.231 lb(US) (6.455 kg)
Unit Type of Package 2	P12
Number of Units in Package 2	15
Package 2 Height	35.433 in (90.000 cm)
Package 2 Width	31.496 in (80.000 cm)
Package 2 Length	47.244 in (120.000 cm)
Package 2 Weight	239.918 lb(US) (108.825 kg)

Contractual warranty

Warranty (in months)	18
----------------------	----



Environmental Data

Schneider Electric aims to achieve Net Zero status by 2050 through supply chain partnerships, lower impact materials, and circularity via our ongoing “Use Better, Use Longer, Use Again” campaign to extend product lifetimes and recyclability.

[Environmental Data explained >](#)

[How we assess product sustainability >](#)

Environmental footprint

Total lifecycle Carbon footprint	293 kg CO2 eq.
Environmental Disclosure	Product Environmental Profile
Carbon footprint of the manufacturing phase [A1 to A3]	36 kg CO2 eq.
Carbon footprint of the distribution phase [A4]	0.7 kg CO2 eq.
Carbon footprint of the installation phase [A5]	1 kg CO2 eq.
Carbon footprint of the use phase [B2, B3, B4, B6]	243 kg CO2 eq.
Carbon footprint of the end-of-life phase [C1 to C4]	13 kg CO2 eq.

Use Better

Materials and Substances

Packaging made with recycled cardboard	Yes
Packaging without single use plastic	Yes
EU RoHS Directive	Compliant
REACH Regulation	REACH Declaration
PVC free	Yes

Use Longer

Lifetime extension

Repair	No
--------	----

Use Again

Repack and remanufacture

Recyclability potential, in %	76
Circularity Profile	No need of specific recycling operations
Take-back	No
WEEE Label	 The product must be disposed on European Union markets following specific waste collection and never end up in rubbish bins.

Dimensions Drawings

Dimensions

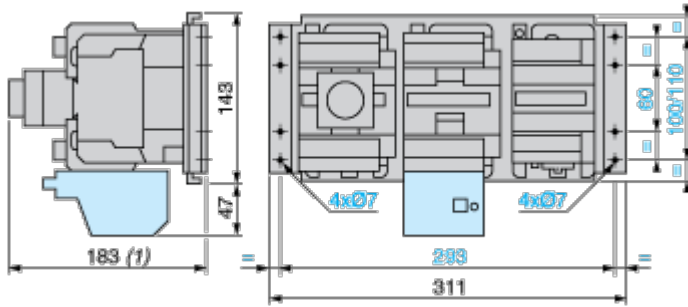

(1) +4 mm with sealing cover

Connections and Schema

Wiring

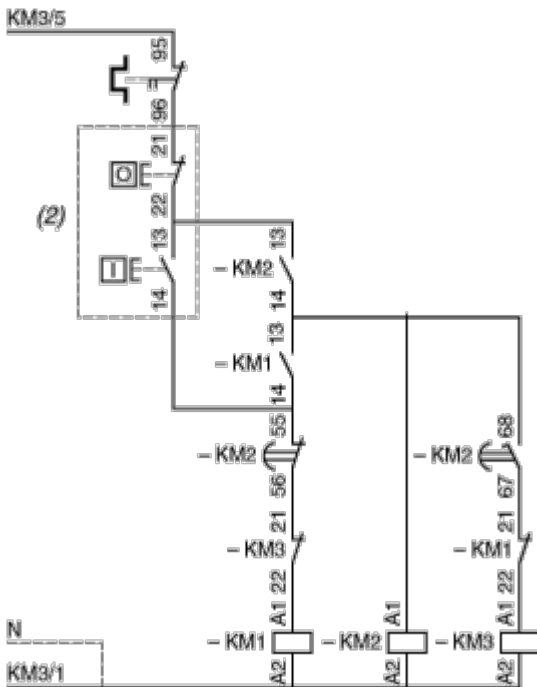
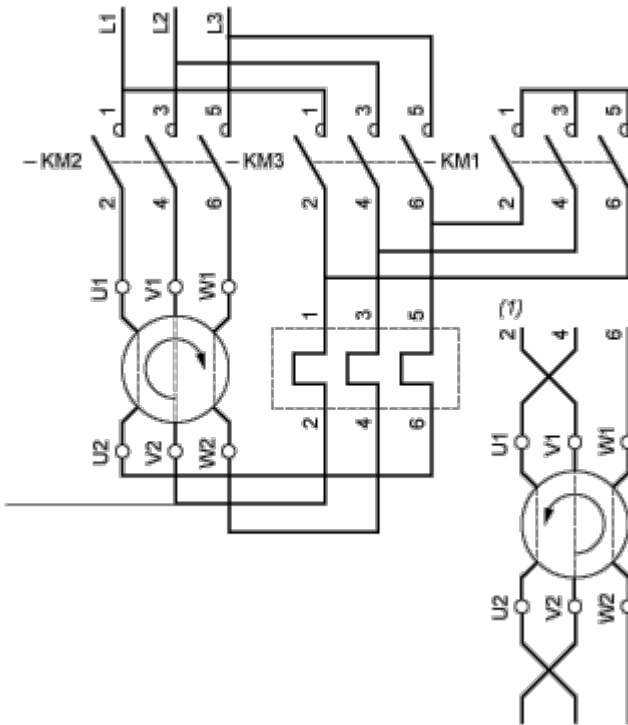

- (1) Recommended cabling for reversal of motor rotation (standard motor, viewed from shaft end).
- (2) Remote control.

NOTE: LC3 D09A to D18A: Mechanical interlock between KM3 and KM1.

