

FUJI SERVO SYSTEM

# FALDIC- $\alpha$ Series



# FALDIC $\alpha$

FUJI SERVO SYSTEM

SIMPLE & SMART

## CONTENTS

- 4 Features
- 9 Explanation of Model Codes
- 10 Specifications of Servo Amplifier
- 11 Connection Diagram (Reference)
- 12 Specifications of Servomotor
- 16 External Dimensions
- 24 Option/Peripheral Equipment
- 33 Model List
- 37 Service Network
- 38 Product Warranty
- 39 Reference Material

## Servo system for evolving machines

# FALDIC $\alpha$



FUJI SERVO SYSTEM

To accommodate a wide range of needs, our new, original vibration suppressing control function and notch filter have been incorporated in the more refined FALDIC- $\alpha$  series, the servo system for evolving machines. The series, which cover the capacity range of 0.05kW to 15kW, are equipped with high-precision functions that would contribute to the betterment of performance of a variety of machines. They facilitate building optimal systems that meet your needs. The FALDIC- $\alpha$  will establish a new standard for servo systems and add much more values to your shop floor.







# Line of Products of FALDIC- $\alpha$ Series

## Servo Amplifier

Model	Type	Host interface	Power supply	Capacity	Applicable motor series
<b>FALDIC-<math>\alpha</math></b> 	V type Position, speed and torque control	DI/DO	Single-phase 100 to 115V	0.05 to 0.375kW	GYS
			3-phase 200 to 230V	0.05 to 5.0kW	GYS GYC GYA
	L type Built-in linear positioning function	SX bus T-link RS-485	3-phase 200 to 230V	0.05 to 5.0kW	GYS GYC
<b>Medium capacity FALDIC-<math>\alpha</math></b> 	V type Position, speed and torque control	DI/DO SX bus	3-phase 200 to 230V	2.9 to 15kW	GYM
	L type Built-in linear positioning function	DI/DO SX bus	3-phase 200 to 230V	2.9 to 15kW	GYM

## Servomotor

Model	Type	Rated speed (max. speed)	Power supply	Capacity	Encoder
<b>GYS motor</b> 	Slim type	3000r/min (5000r/min)	Single-phase 100V class	0.05 to 0.375kW	16-bit ABS/INC 16-bit INC
		3000r/min (5000r/min)	3-phase 200V class	0.05 to 5.0kW	16-bit ABS/INC 16-bit INC
<b>GYC motor</b> 	Cubic type	3000r/min (5000r/min)	3-phase 200V class	0.1 to 2.0kW	16-bit ABS/INC 16-bit INC
<b>GYA motor</b> 	Low base type	1500r/min (2500r/min)	3-phase 200V class	0.5 to 2.5kW	16-bit ABS/INC
<b>GYM motor</b> 	Medium capacity type	1500r/min (7.5kW or less: 3000r/min 11kW or more: 2000r/min)	3-phase 200V class	2.9 to 15kW	16-bit INC



## Suppresses mechanical vibrations to the maximum extent.

■ Equipped with a “Vibration Suppressing Control Function” which is an effective countermeasure for suppressing vibration of the tips of robot arms, etc.

### Fuji's original vibration control function (Patent pending)

In high tact operation of mechanisms with low rigidity, such as the tips of robot arms, suppression of arm tip vibration is a major factor in shortening tact time. In the FALDIC- $\alpha$  series, Fuji's original "Vibration Suppressing Control Function" is standard equipment. It reduces vibration in machines with low rigidity and realizes high machine tact.

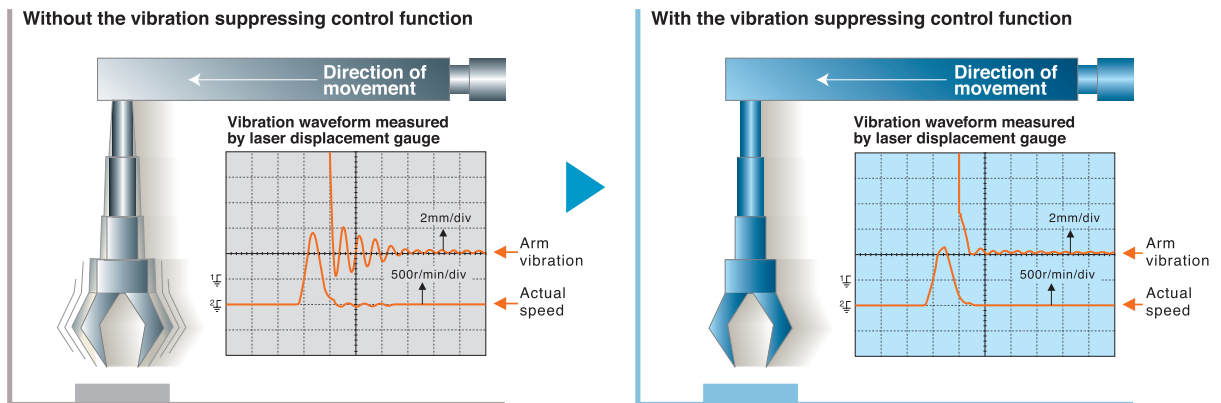

■ Equipped with a notch filter and servo analysis function.

### Notch Filter

This function is for the purpose of reducing machine resonance. By setting the data on the resonance point, which differs in each machine, as a parameter in the servo amplifier, the machine resonance occurring in that point can be reduced.

### Servo Analysis Function (Option)

In order to utilize the "Vibration Suppressing Control Function" and "Notch Filter," etc. effectively, it is necessary to analyze the "resonance frequencies" that are inherent in each machine. If the "Servo Analysis Function" offered in the optional personal computer loader is used, it can analyze the data for the machine system simply, eliminating the needs for complicated calculations and adjustments which are dependent on intuition.

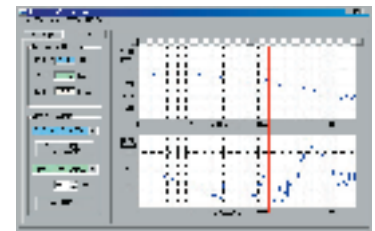

(Data acquisition example. The notch filter setup values and vibration suppressing control setup values can be easily determined.)



## Designed for high performance and high precision.

■ Command following servo (positional deviation  $\approx$  zero)

### Positioning settling time is 1 ms or less.

Through the newly developed feed forward control which compensates for servo delay, operation even during acceleration and deceleration can be done with positional deviation almost zero. A positioning completed signal can be output virtually simultaneously with the end of the command pulse (within 1 ms).

■ Frequency response 600Hz

Frequency response 600Hz has been achieved. As a high-performance servo system, high-tact operation and high-frequency acceleration/deceleration can be realized.

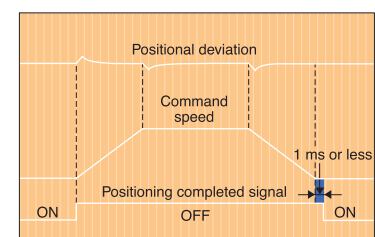



## Stable rotation at a low speed

### ■ New built-in 65536P/R high-resolution encoder

By achieving high resolution, the series reduce motor instability and realize smooth machine operations.

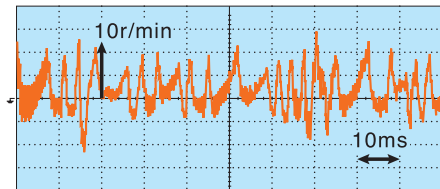

Conventional encoder (8192P/R)

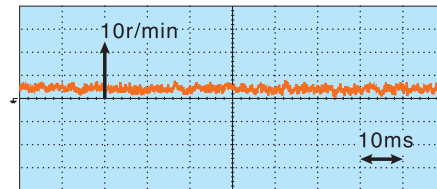

16-bit encoder (65536P/R)



## Without spaces between servo amplifiers, you can save the space for the control panel.

Conventionally, spaces were required between servo amplifiers to counteract the heat generated by them. The FALDIC- $\alpha$  series allow closely fitted installation, which reduces the space required for the installation on the control panel.

### ■ Example where 5 servo amplifiers are used

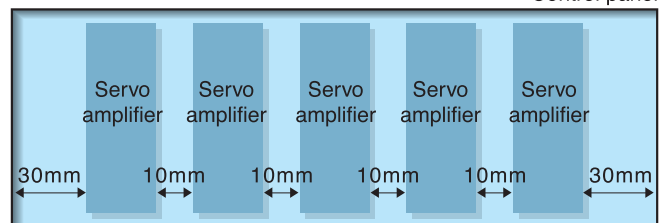

By introducing FALDIC- $\alpha$  series,

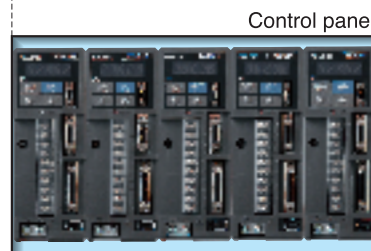

You can save space of 100mm for the control panel.

\*80% ED rating applies to installation without spaces. There are no limitations if there are spaces of 5mm or more between the servo amplifiers.



## Supporting overseas standards

The standard FALDIC- $\alpha$  specifications are compliant with the "CE Marking" and "UL/cUL", which makes them global servo amplifiers.





# Positioning control function built-in types

The L type and R type, the servo amplifiers with the built-in positioning control are available. You can configure the system without positioning modules.

<System configuration example of the VV□ type >

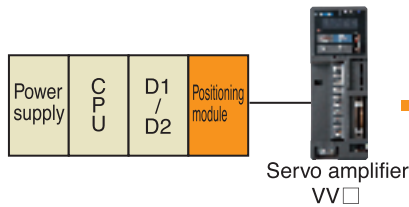

Positioning modules are not required.

<System configuration example of the LP□/RP□ types>

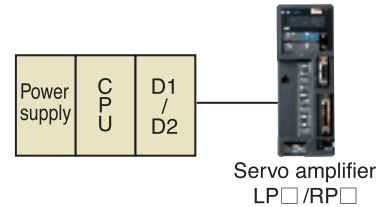

## ■RYS-L type (Linear motion) The linear positioning control built-in type

Maximum command value:  $\pm 79,999,999$

The servo amplifier holds positioning data that covers 99 points. All you need to do is specify the positioning data numbers from the host interface to operate the servo amplifier for positioning based on the specified positioning data.

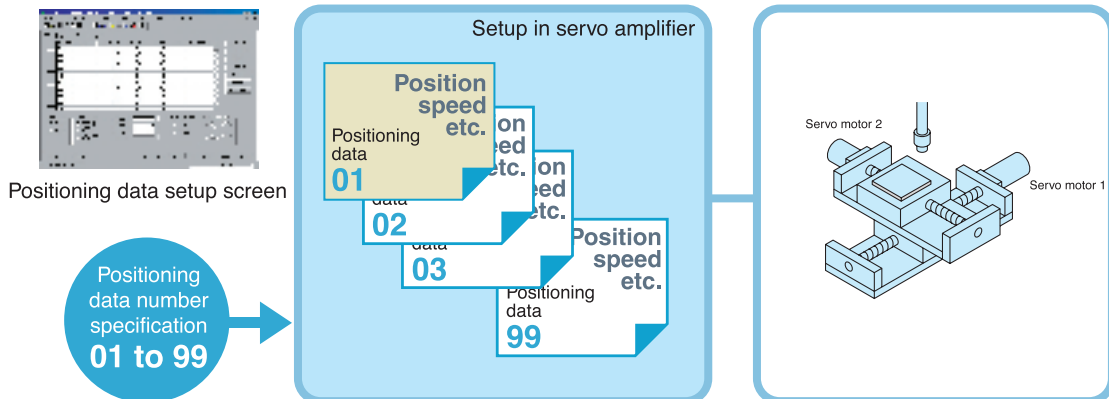

## ■RYS-R type (Rotation) The rotation indexing function built-in type

Maximum division count: 30,000

It can divide one rotation ( $360^\circ$ ) into up to 30,000 areas ( $0.012^\circ$  per area). All you need to do is specify the station number (stop position) from the host interface to stop the amplifier at the position.

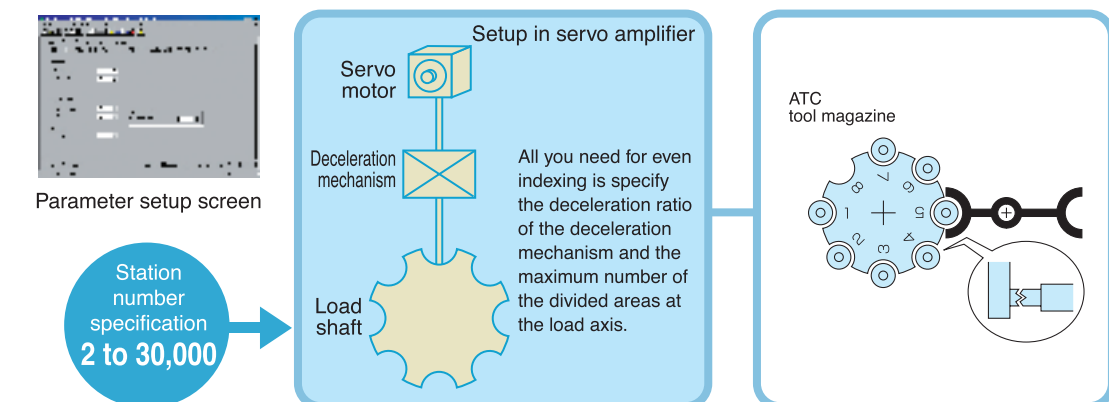



# Realizing optimal system configuration flexibly and easily

## ■ Master controller and servo amplifiers are directly connected via bus.

Positioning modules are not required for controlling servo amplifiers with the MICREX-SX system when SX bus is used. Wiring for this type of configuration is very simple.

### System configuration example

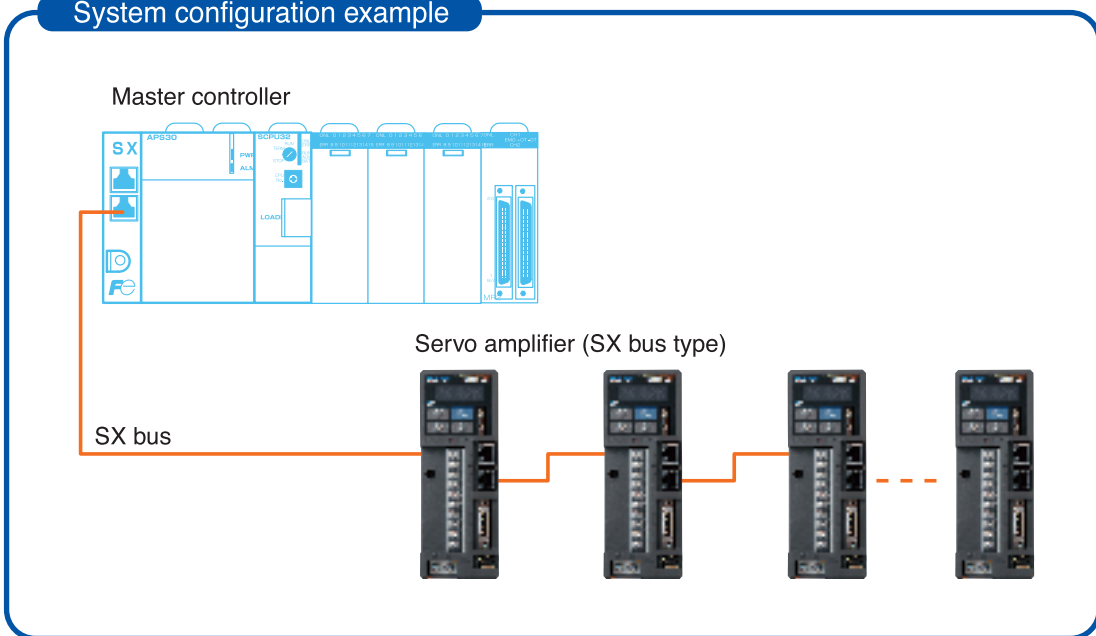

## ■ Various software applications best suited for motion control (FB or Function Block) are available.

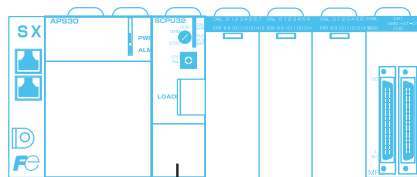

Servo control with the MICREX-SX system supports various FB operations such as PTP operations, interpolating operations and advanced synchronous operations.

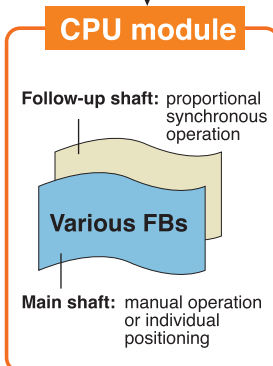

The interface with FBs is very simple. You can readily create your own applications.

Customer machine <rotary shear, for example>

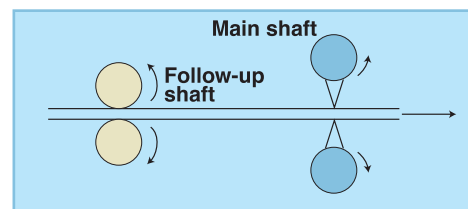

A wide range of FBs are available best suited for motion control you need.



## Explanation of Model Codes

### Servo amplifier

**RYS 201 S 3 - V V X 6**

Code	[Applicable motor output]
500	$50 \times 10^0 = 0.05\text{kW}$
201	$20 \times 10^1 = 0.2\text{kW}$

Code	[Series]
S	Standard
A	Low base
M	Medium capacity FALDIC- $\alpha$

Code	[Order of development]

Code	[Major functions]
V	Position, speed and torque control
L	Built-in linear positioning function
R	Built-in rotation indexing function

Code	[Input voltage]
Blank	3-phase 200V
6	Single phase 100V

Code	[Encoder, others]
X	16-bit ABS/INC, VVX type
S	16-bit ABS/INC, standard
G	16-bit ABS/INC, gateway supported
K	16-bit ABS/INC [coupling], control function supported

\* Code K applies to only medium capacity type $\alpha$

Code	[Upper interface]
V	DI/DO (speed)
P	DI/DO (position)
S	SX bus
T	T-link
R	RS-485

### Servomotor (GYS,GYC,GYA)

**GYS 201 D C 1 - S 6 A - B**

Code	[Basic type]
GYS	Slim type
GYC	Cubic type
GYA	Low base type

Code	[Rated output]
500	$50 \times 10^0 = 0.05\text{kW}$
201	$20 \times 10^1 = 0.2\text{kW}$

Code	[Rated speed]
D	3000r/min
B	1500r/min

Code	[Installation method]
C	By securing flange

Code	[Order of development]

Code	[Brake]
Blank	Not provided
B	Provided

Code	[Oil seal/shaft]	Applicable motor	
		Single phase 100V	3-phase 200V
A	Without an oil seal, straight shaft with a key	○	○
B	Without an oil seal, straight shaft without a key	◎	◎

◎: Standard item ○: Optional item

Code	[Input voltage]
Blank	200V
6	100V
8	Common to 100V and 200V

Code	[Encoder]
S	16-bit ABS/INC
C	16-bit INC

### Servomotor (GYM)

**GYM 292 B C 1 - K C B - G06**

Code	[Basic type]
GYM	Medium capacity type

Code	[Rated output]
292	$29 \times 10^2 = 2.9\text{kW}$
113	$11 \times 10^3 = 11\text{kW}$

Code	[Rated speed]
B	1500r/min

Code	[Installation method]
C	By securing flange

Code	[Order of development]

Code	[Encoder]
K	16-bit INC [coupling]
A	16-bit ABS [coupling] (Option)

Code	[Gear presence/absence and gear ratio]
Blank	Not provided
G06	1/6 (Option)
G11	1/11 (Option)
G21	1/21 (Option)
G29	1/29 (Option)

Code	[Brake]
Blank	Not provided (standard)
B	Provided (Option)

Code	[Oil seal/shaft]
B	Without an oil seal, straight shaft without a key (Option)
C	Without an oil seal, straight shaft with a key, tapped (standard)

## Basic specifications

Applicable motor rated speed	3000r/min				3000r/min										1500r/min (low base)			1500r/min (medium capacity type α)																
	0.05	0.1	0.2	0.375	0.05	0.1	0.2	0.4	0.75	1.0	1.5	2.0	3.0	4.0	5.0	0.5	1.5	2.5	2.9	4.0	5.5	7.5	11	15										
Applicable motor output [kW]	500	101	201	371	500	101	201	401	751	102	152	202	302	402	502	—	—	—	—	—	—	—	—	—										
Amplifier type <sup>1)</sup>	RYS**S3-△△△□	—	—	—	—	—	—	—	—	—	—	—	—	—	—	501	152	252	—	—	—	—	—	—										
	RYS**A3-VVX or VVS	—	—	—	—	—	—	—	—	—	—	—	—	—	—	—	—	—	—	—	—	—	—	—										
	RYS**M3-△△△	—	—	—	—	—	—	—	—	—	—	—	—	—	—	—	—	—	292	402	552	752	113	153										
Mass [kg]	0.9				0.9				1.2				1.5				2.0			4.6			4.7			5.2			8.5			25		
Input	Phase	Single-phase				3-phase (Single-phase input allowed for 200W or less only)																												
	Voltage	AC100 to 115V, -15 to +10%				200 to 230V, -15 to +10%										200 to 230V*2, -15 to +10%																		
	Frequency	50/60Hz																																
	Control input voltage	Single-phase:100 to 115V AC, -15 to +10%				Single-phase:200 to 230V AC, -15 to +10%																												
Output	Control method	IGBT sinusoidal PWM drive																																
	Overload resistance	3[s]	300%										300%			242%			250%			236%												
		1.5[s] *3	—										—			—			—															
	Control method	Regenerative braking for DC link circuit																																
Feedback	16-bit serial encoder (ABS/INC)																																	
Capability and function	V type control function	Max speed	5000r/min										2500r/min			3000r/min			2000r/min															
		Speed control range *4	1:5000										1:3000			1:3000																		
		Frequency response *5	600Hz										300Hz			300Hz																		
		Speed fluctuation ratio	Within ±1[r/min] :load fluctuation (0 to 100%), power fluctuation (-10% to +10%) Within ±0.2% :temperature fluctuation (25°C±10°C at rated rotation speed and analog input operation)																															
		Resolution	2 <sup>16</sup> (=65536)/1 rotation																															
		Common	Speed control	Manual operation (analog voltage, multi-stage 7-speed)																														
			Position control	Manual operation (analog voltage, multi-stage 7-speed, interrupt positioning), pulse train (pulse train magnification 1, pulse train magnification 2)																														
			Torque control	Manual operation (analog voltage)																														
		L type control function	Position management	INC/ABS selectable. When ABS is selected, a battery is mounted on the amplifier. INC: Current position lost when power is turned off. No rotation limitation ABS: Current position restored upon power recovery. Rotation limitation provided (rotation range:±32767 rotations)																														
			Home setup	Home position LS and Z phase, position presetting, homing (4 patterns)																														
Accessories functions	Override, brake timing, speed command auxiliary input, etc.																																	
Position control	Automatic start (address designation, sequential start, immediate start), manual operation (analog voltage, multi-stage 7-speed, interrupt positioning), pulse train (pulse train magnification 1, pulse train magnification 2), homing (4 patterns)																																	
Position management	INC/ABS selectable. When ABS is selected, a battery is mounted on the amplifier. INC: Current position lost when power is turned off. No rotation limitation ABS: Current position regenerated upon power recovery. Rotation limitation provided (rotation range:±32767 rotations)																																	
Home setup	Home position LS and Z phase, position presetting																																	
Position data count	99 points (position, speed, timer, M code, and various statuses)																																	
Max position setup	±79,999,999 (× Unit value)																																	
Positioning method	Absolute/incremental																																	
Accessories function	Override, brake timing, etc.																																	
R type control function	Position control	Automatic start (station designation), manual operation (analog voltage, multi-stage 3-speed, manual indexing), pulse train (pulse train magnification 1, pulse train magnification 2), homing																																
	Position management	INC/ABS selectable. When ABS is selected, a battery is mounted on the amplifier. INC: Current position lost when power is turned off. No rotation limitation ABS: Current position regenerated upon power recovery. No rotation limitation.																																
	Home setup	Home position LS and Z phase, position presetting																																
	Max division count	7999 (BCD setup)/30000 (Binary setup)																																
	Deceleration ratio	1/9999 to 1/1																																
Protective function (Alarm indication)	Positioning method	Shortcut/forward rotation/reverse rotation, absolute/incremental																																
	Accessories functions	Override, brake timing, second home position, etc.																																
	Overcurrent (OC), Overspeed (OS), Undervoltage (Lv), Overvoltage (Hv), Encoder error (Et), Control power error (Ct), Memory error (dE), Combination error (CE), Regenerative transistor overheat (rH2), Encoder communication error (EC), CONT overlapping (CIE), Overload (OL), Regenerative resistor overheat (rH), Deviation overflow (OF), Amplifier overheat (AH), Encoder overheat (EH), Multi-rotation data loss (AL), Multi-rotation overflow (AF)																																	
	Note: *Combination error (CE) and *Regenerative resistor overheat (rH) are not supported with the medium capacity type FALDIC-α (model of 1500r/min, 2.9kW or above). Note: *Encoder overheat (EH) is not supported with the medium capacity type FALDIC-α (model of 1500r/min, 2.9kW or above) during incremental drive of the motor.																																	
Applicable environment	Installation place	Indoors (free from direct sunshine), altitude ≤ 1000m, free from corrosive and flammable gases, oil mist and dust In case of compliance with CE marking Models compliant with EU directive: pollution degree 2, over voltage category II																																
	Temperature/humidity	-10 to 55°C/10 to 90%RH (without condensation)																																
	Vibration/shock resistance	4.9m/s <sup>2</sup> /19.6m/s <sup>2</sup>																																
Standards	UL/cUL (UL508c), CE marking (low voltage directive EN50178)																																	

- \*1) △ represents an alphabet depending on the amplifier type (VVX, VVS, VSS, VVK, VSK, LPS, LSS, LTS, LRS, LPK, LSK, RPS, RSS, RTS)  
□ represents "6" or "no mark" depending on the input power type ("6" = single-phase 100V input, "no mark" = 3-phase 200V input)
- \*2) The specifications of 220 to 230V/50Hz with motor output 5.5 to 15kW are available as option.
- \*3) The following types can only support 1.5 [s] overload rating (450%): "VVS" "VSS" "LPS" "LSS" "LTS" "LRS" "RPS" "RSS" "RTS"
- \*4) The minimum rotation speed is the speed that does not result in stop at the rated load.
- \*5) Motor shaft converted load inertia moment (JL) = Motor inertia moment (JM): 100% load

## Interface specifications

Terminal name	Pin Symbol	Specifications
Pulse train input	CA, *CA, CB, *CB	Differential input,max. input frequency ≤ 500kHz, (1) Command pulse/command code, (2) Forward rotation pulse/reverse rotation pulse, (3) two signals at 90-degree phase difference
Divided output *6	FA, *FA, FB, *FB, FZ, *FZ	Differential output,max. output frequency ≤ 500kHz, two signals at 90-degree phase difference, 16 to 16384 [pulses/rev]
Power output for analog input	P10	+10V±0.4V (maximum output current 30mA)
Speed command input	NREF	±10V (Input impedance 20kΩ)
Torque command input (V type only)	TREF	±10V (Input impedance 20kΩ)
Monitor output 1, monitor output 2 *7	MON1, MON2	Output for analog meter (both-side amplitude/single-side amplitude), (1) Speed command, (2) Speed return, (3) Torque command, (4) Position deviation
Power input for sequence signals	P24, M24	External power supply of 24V DC/300mA required.
Sequence input signal	V type :CONT1 to CONT8 L/R type :CONT1 to CONT21	24V DC/10mA (1-point) Can be assigned to each function through parameter setup.
Sequence output signal	V type :OUT1 to OUT5 R type :OUT1 to OUT10	30V DC/50mA (1-point) Can be assigned to each function through parameter setup.
External backup	BAT +, BAT -	Input pin for supplying backup power externally.

- \*6) The RS-485 and T-link types are output via open collector, and maximum output frequency is 200kHz.
- \*7) MON2 only for RS-485 and T-link types.

## Connection Diagram (Reference)

### V type (DI/DO)

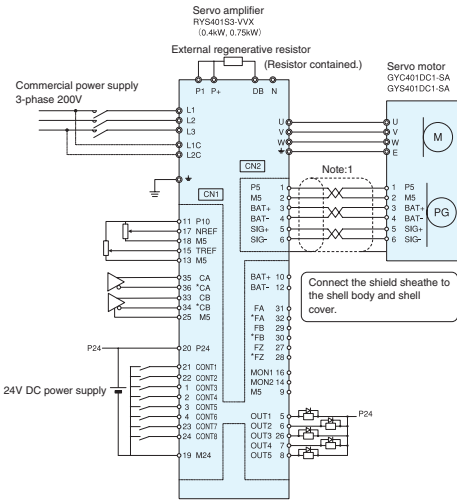

Note: If the optional encoder cable is not to be used, refer to the users manual for details of wiring.

### L/R type (DI/DO)

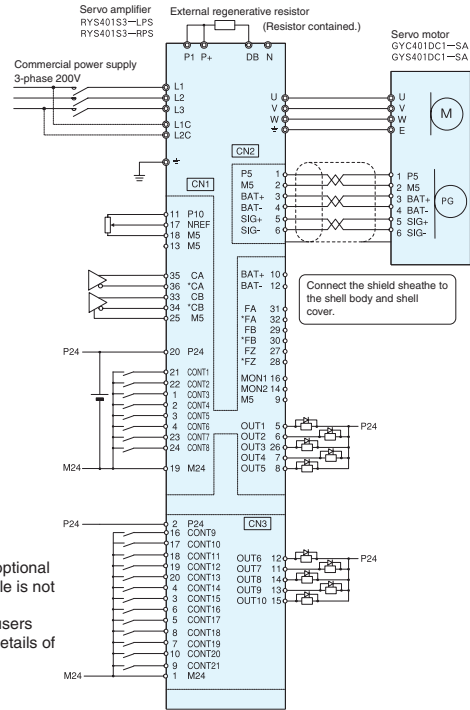

Note: If the optional encoder cable is not to be used, refer to the users manual for details of wiring.

### Amplifier supporting SX bus (VSS,LSS,RSS)

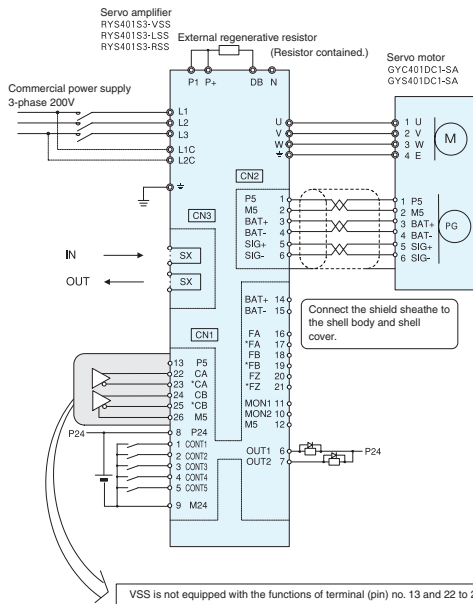

Note: If the optional encoder cable is not to be used, refer to the users manual for details of wiring.

### Amplifier supporting T-link and RS-485 (LTS,LRS,RTS)

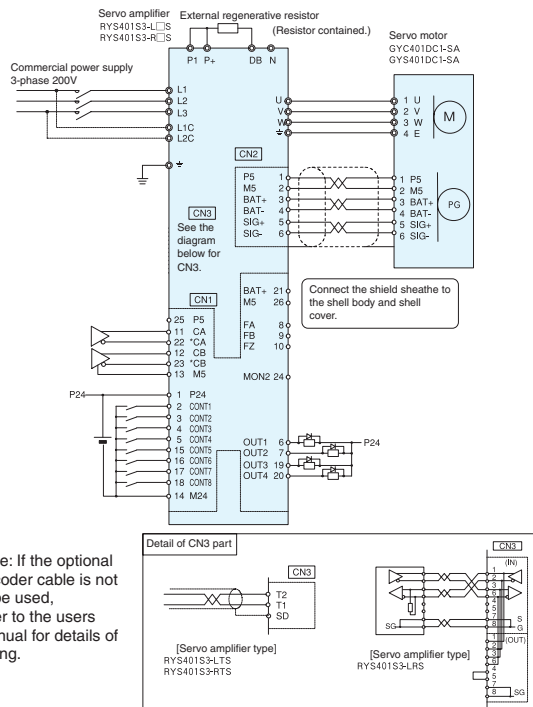

Note: If the optional encoder cable is not to be used, refer to the users manual for details of wiring.



## Caution

The diagram shown above is given as a reference for model selection. When actually using the selected servo system, make wiring connections according to the connection diagram and instructions described in the user's manual.

# Specifications of Servomotor

## GYS motor

### Standard specifications

Note : Use the motor with key when the gear head is being combined with any model (0.05kW to 0.375kW) of the 100V type or the 0.05kW or 0.1kW model of the 200V type.

Motor type	500DC1	101DC1	201DC1	371DC1	500DC1	101DC1	201DC1	401DC1	751DC1
GYS □□□□□□□□□□	-□8B(*1)	-□6B	-□6B	-□6B	-□8B(*1)	-□B	-□A	-□A	-□A
Series	Single-phase 100V series				3-phase 200V series				
Rated output [kW]	0.05	0.1	0.2	0.375	0.05	0.1	0.2	0.4	0.75
Rated torque [N·m]	0.159	0.318	0.637	1.19	0.159	0.318	0.637	1.27	2.39
Rated speed [r/min]	3000								
Max speed [r/min]	5000								
Max torque [N·m]	0.478	0.955	1.91	3.58	0.478	0.955	1.91	3.82	7.17
Inertia moment [kg·m <sup>2</sup> ]	0.0192 x10 <sup>-4</sup>	0.0371 x10 <sup>-4</sup>	0.135 x10 <sup>-4</sup>	0.246 x10 <sup>-4</sup>	0.0192 x10 <sup>-4</sup>	0.0371 x10 <sup>-4</sup>	0.135 x10 <sup>-4</sup>	0.246 x10 <sup>-4</sup>	0.853 x10 <sup>-4</sup>
Rated current [A]	0.85	1.5	2.7	4.8	0.85	1.5	2.7	4.8	8.5
Max current [A]	2.55	4.5	8.1	14.4	2.55	2.55	4.5	8.1	14.4
Insulation class	Class B								
Operation duty type	Continuous								
Degree of enclosure protection	Fully closed, self-cooling (IP55) (excluding the shaft sealing and connectors)								
Pin (motor)	Cable 0.3m (with connector)								
Pin (detector)	Cable 0.3m (with connector)								
Overheat protection	Not provided (detected on the servo amplifier)								
Installation method	By securing flange IMB5 (L51), IMV1 (L52), IMV3 (L53)								
Shaft extension	Straight shaft, no key				Straight shaft with a key				
Paint color	N1.5								
Encoder	16-bit serial encoder (both ABS and INC, INC only)								
Vibration level	V5 or below								
Installation place	Indoors (free from direct sunshine), altitude ≤ 1000m, free from corrosive and flammable gases, oil mist and dust								
Ambient temperature/humidity	-10 to +40°C, 90 % RH (without condensation)								
Vibration resistance [m/s <sup>2</sup> ]	49								
Mass [kg]	0.45 (0.62)	0.55 (0.72)	1.2 (1.7)	1.8 (2.3)	0.45 (0.62)	0.55 (0.72)	1.2 (1.7)	1.8 (2.3)	3.4 (4.2)
( ) indicates brake-incorporated type									
Standards	UL/cUL (UL1004), CE marking (EN60034-1, EN60034-5), RoHS Directive								

\*1) The motor with the rated output of 0.05kW is used for both 100V type and 200V type.

### Brake specification (motor equipped with a brake)

Note : Use the motor with key when the gear head is being combined with any model (0.05kW to 0.375kW) of the 100V type or the 0.05kW or 0.1kW model of the 200V type.

Motor type	500DC1	101DC1	201DC1	371DC1	500DC1	101DC1	201DC1	401DC1	751DC1
GYS □□□□□□□□□□	-□8B-B(*1)	-□6B-B	-□6B-B	-□6B-B	-□8B-B(*1)	-□B-B	-□A-B	-□A-B	-□A-B
Series	Single-phase 100V series				3-phase 200V series				
Static friction torque [N·m]	0.3		1.27		0.3		1.27		2.45
Rated voltage [V]	DC24V±10%								
Attraction time [ms]	35		40		35		40		60
Release time [ms]	10		20		10		20		25
Power consumption [W]	6.1 (at 20°C)		7.3 (at 20°C)		6.1 (at 20°C)		7.3 (at 20°C)		8.5 (at 20°C)

\*1) The motor with the rated output of 0.05kW is used for both 100V type and 200V type.  
Note: The brake is used to hold the rotor.

### Torque characteristic diagram

#### 100V series

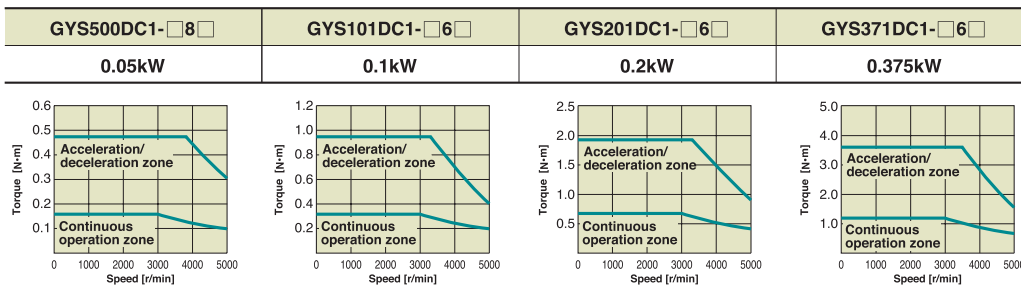

#### 200V series

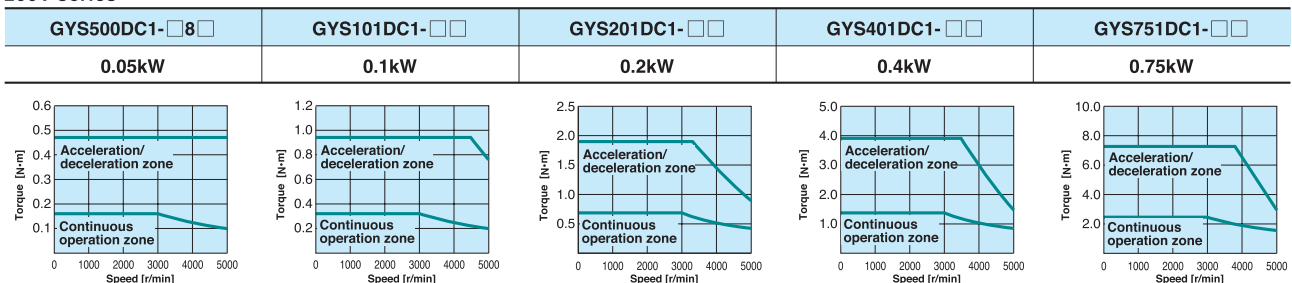

## Specifications of Servomotor

### GYS motor

#### Standard specifications

Motor type GYS □□□□□□□□-□□□□	102DC1 -SA	152DC1 -SA	202DC1 -SA	302DC1 -SA	402DC1 -SA	502DC1 -SA
Series	3-phase 200V series					
Rated output [kW]	1.0	1.5	2.0	3.0	4.0	5.0
Rated torque [N·m]	3.18	4.78	6.37	9.55	12.7	15.9
Rated speed [r/min]	3000					
Max speed [r/min]	5000					
Max torque [N·m]	9.55	14.3	19.1	28.7	38.2	47.8
Inertia moment [kg·m <sup>2</sup> ]	1.73 x10 <sup>-4</sup>	2.37 x10 <sup>-4</sup>	3.01 x10 <sup>-4</sup>	8.32 x10 <sup>-4</sup>	10.8 x10 <sup>-4</sup>	12.8 x10 <sup>-4</sup>
Rated current [A]	7.1	9.6	12.6	18	24	30
Max current [A]	21.3	28.8	37.8	54	72	90
Insulation class	Class F					
Operation duty type	Continuous					
Degree of enclosure protection	Fully closed, self-cooling (IP55) (excluding the shaft sealing and connectors)					
Pin (motor)	Canon connector					
Pin (detector)	Canon connector					
Overheat protection	Not provided (detected on the servo amplifier)					
Installation method	By securing flange IMB5 (L51), IMV1 (L52), IMV3 (L53)					
Shaft extension	Straight shaft with a key					
Paint color	N1.5					
Encoder	16-bit serial encoder (both ABS and INC)					
Vibration level	Rated speed or below : V10 or below, 3001r/min or higher: V15 or below					
Installation place	Indoors (free from direct sunshine), altitude ≤ 1000m, free from corrosive and flammable gases, oil mist and dust					
Ambient temperature/humidity	-10 to +40°C, 90 % RH (without condensation)					
Vibration resistance [m/s <sup>2</sup> ]	24.5					
Mass [kg] ( ) indicates brake-incorporated type	4.4 (5.9)	5.2 (6.8)	6.3 (7.9)	11 (13)	13.5 (15.5)	16 (18)
Standards	UL/cUL (UL1004), CE marking (EN60034-1, EN60034-5), RoHS Directive					

#### Brake specification (motor equipped with a brake)

Motor type GYS □□□□□□□□-□□□□	102DC1 -SA-B	152DC1 -SA-B	202DC1 -SA-B	302DC1 -SA-B	402DC1 -SA-B	502DC1 -SA-B
Series	3-phase 200V series					
Static friction torque [N·m]	6.86			17		
Rated voltage [V]	DC24V±10%					
Attraction time [ms]	60			120		
Release time [ms]	10			30		
Power consumption [W]	17 (at 20°C)			12 (at 20°C)		

Note: The brake is used to hold the rotor.

#### Torque characteristic diagram

##### 200V series

GYS102DC1-S □	GYS152DC1-S □	GYS202DC1-S □
1.0kW	1.5kW	2.0kW

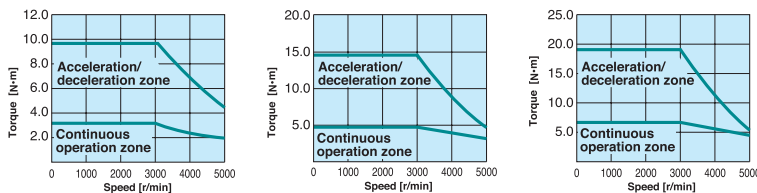

GYS302DC1-S □	GYS402DC1-S □	GYS502DC1-S □
3.0kW	4.0kW	5.0kW

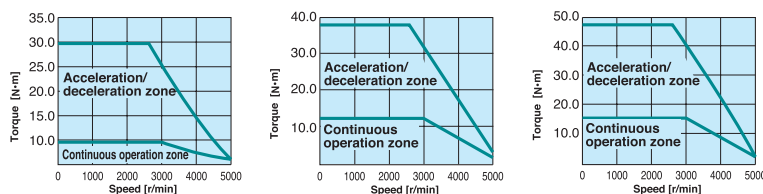

## GYC motor

### Standard specifications

Motor type GYC □□□□□□-□□□□	101DC1 -□A	201DC1 -□A	401DC1 -□A	751DC1 -□A	102DC1 -SA	152DC1 -SA	202DC1 -SA
Series	3-phase 200V series						
Rated output [kW]	0.1	0.2	0.4	0.75	1.0	1.5	2.0
Rated torque [N·m]	0.318	0.637	1.27	2.39	3.18	4.78	6.37
Rated speed [r/min]	3000						
Max speed [r/min]	5000						
Max torque [kg·m <sup>2</sup> ]	0.955	1.91	3.82	7.17	9.55	14.3	19.1
Inertia moment [A]	0.0577×10 <sup>-4</sup>	0.213×10 <sup>-4</sup>	0.408×10 <sup>-4</sup>	1.21×10 <sup>-4</sup>	3.19×10 <sup>-4</sup>	4.44×10 <sup>-4</sup>	5.69×10 <sup>-4</sup>
Rated current [A]	1.0	1.5	2.6	4.8	6.7	9.6	12.6
Max current	3.0	4.5	7.8	14.4	20.1	28.8	37.8
Insulation class	Class B				Class F		
Operation duty type	Continuous						
Degree of enclosure protection	Fully closed, self-cooling (IP55) (excluding the shaft sealing and connectors)						
Pin (motor)	Cable 0.3m (with connector)				Canon connector		
Pin (detector)	Cable 0.3m (with connector)				Canon connector		
Overheat protection	Not provided (detected on the servo amplifier)						
Installation method	By securing flange IMB5 (L51), IMV1 (L52), IMV3 (L53)						
Shaft extension	Straight shaft with a key						
Paint color	N1.5						
Encoder	16-bit serial encoder (both ABS and INC, INC only)				16-bit serial encoder (both ABS and INC)		
Vibration level	V5 or below				Rated speed or below : V10 or below, 3001r/min or higher: V15 or below		
Installation place	Indoors (free from direct sunshine), altitude ≤ 1000m, free from corrosive and flammable gases, oil mist and dust						
Ambient temperature/humidity	-10 to +40°C, 90 % RH (without condensation)						
Vibration resistance [m/s <sup>2</sup> ]	49				24.5		
Mass [kg] ( ) indicates brake-incorporated type	0.75 (1.0)	1.3 (1.9)	1.9 (2.6)	3.5 (4.3)	5.7 (8.0)	7.0 (9.8)	8.2 (11.0)
Standards	UL/cUL (UL1004), CE marking (EN60034-1, EN60034-5), RoHS Directive						

### Brake specification (motor equipped with a brake)

Motor type GYC □□□□□□-□□□□	101DC1 -□A-B	201DC1 -□A-B	401DC1 -□A-B	751DC1 -□A-B	102DC1 -SA-B	152DC1 -SA-B	202DC1 -SA-B
Series	3-phase 200V series						
Static friction torque [N·m]	0.318	1.27	2.39	17			
Rated voltage [V]	DC24V±10%						
Attraction time [ms]	60	80	50	120			
Release time [ms]		40	80	30			
Power consumption [W]	6.5 (at 20°C)	9 (at 20°C)	8.5 (at 20°C)	12 (at 20°C)			

Note: The brake is used to hold the rotor.

### Torque characteristic diagram

200V series

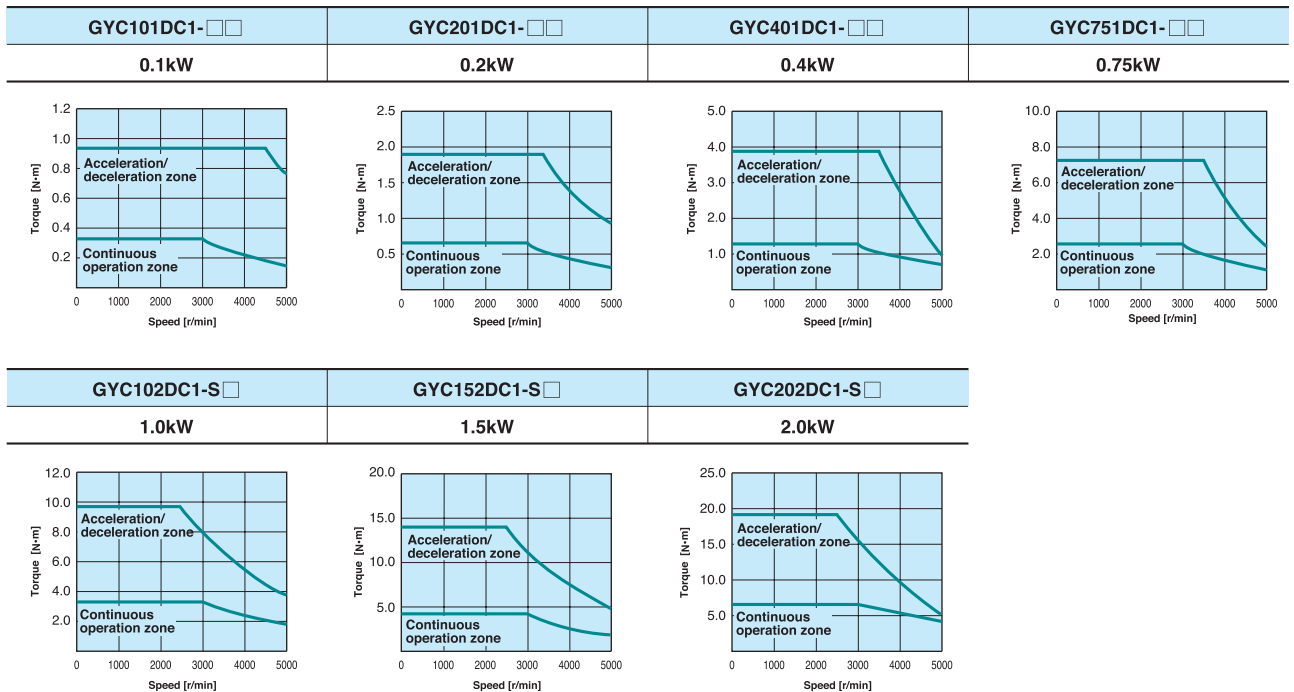

Specifications of Servomotor

GYA and GYM motors

Standard specifications

Motor series	GYA motor			GYM motor					
Motor type	GYA501BC1 -SA	GYA152BC1 -SA	GYA252BC1 -SA	GYM292BC1 -KC	GYM402BC1 -KC	GYM552BC1 -KC	GYM752BC1 -KC	GYM113BC1 -KC	GYM153BC1 -KC
Series	200V series								
Rated output [kW]	0.5	1.5	2.5	2.9	4.0	5.5	7.5	11	15
Rated torque [N · m]	3.18	9.55	15.9	18.6	25.5	35.0	48.0	70.0	95.4
Rated speed [r/min]	1500								
Max speed [r/min]	2500			3000				2000	
Max torque [kg · m <sup>2</sup> ]	9.55	28.7	47.7	45.1	63.4	87.6	119	175	224
Inertia moment [A]	$3.19 \times 10^{-4}$	$8.73 \times 10^{-4}$	$13.7 \times 10^{-4}$	$46 \times 10^{-4}$	$68 \times 10^{-4}$	$89 \times 10^{-4}$	$12.5 \times 10^{-4}$	$28.1 \times 10^{-4}$	$31.5 \times 10^{-4}$
Rated current [A]	3.9	9.6	18.5	23.8	30	42.1	54.7	58.6	78
Max current	11.7	28.8	55.5	56	76	110	130	140	170
Insulation class	Class F								
Operation duty type	Continuous								
Degree of enclosure protection	Fully closed, self-cooling (IP55) (excluding the shaft sealing and connectors)			Fully closed, self-cooling (IP67)(excluding the shaft sealing)					
Pin (motor)	Canon connector								
Pin (detector)	Canon connector								
Overheat protection	Not provided (detected on the servo amplifier)								
Installation method	By securing flange IMB5 (L51), IMV1 (L52), IMV3 (L53)								
Shaft extension	Straight shaft with a key			Straight shaft with a key, tapped					
Paint color	N1.5								
Encoder	16-bit serial encoder (both ABS and INC)			Standard : 16-bit serial encoder (INC) Option : 16-bit serial encoder (ABS)					
Vibration level	Rated speed or below: V10 or below, 3001r/min or higher: V15 or below			V5 or below					
Applicable location/sea level	Indoors (free from direct sunshine), altitude $\leq$ 1000m, free from corrosive and flammable gases, oil mist and dust								
Ambient temperature/humidity	-10 to +40°C, 90 % RH (without condensation)			0 to +40°C, 90 % RH (without condensation)					
Vibration resistance [m/s <sup>2</sup> ]	24.5								
Mass [kg]	5.7	11	16	18	23	30	40	57.5	86
Standards	UL/cUL (UL1004), CE marking (EN60034-1, EN60034-5), RoHS Directive								

Torque characteristic diagram

GYA motor characteristics

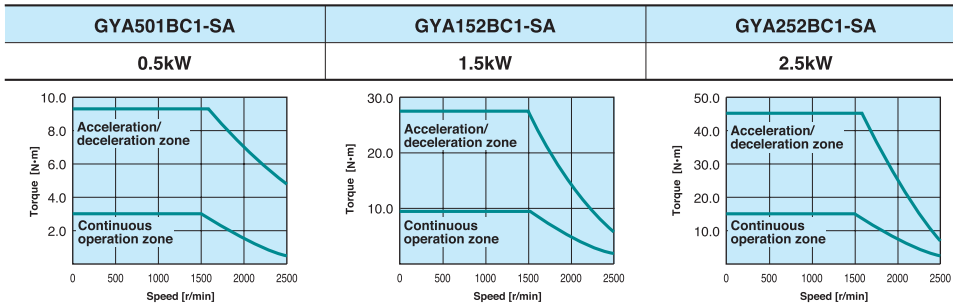

GYA motor characteristics

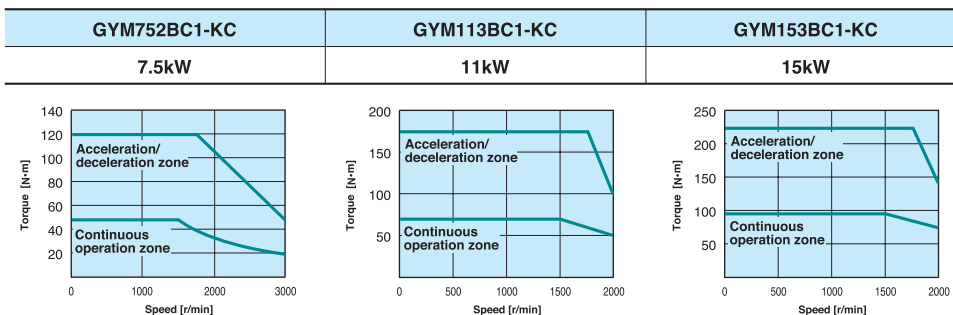
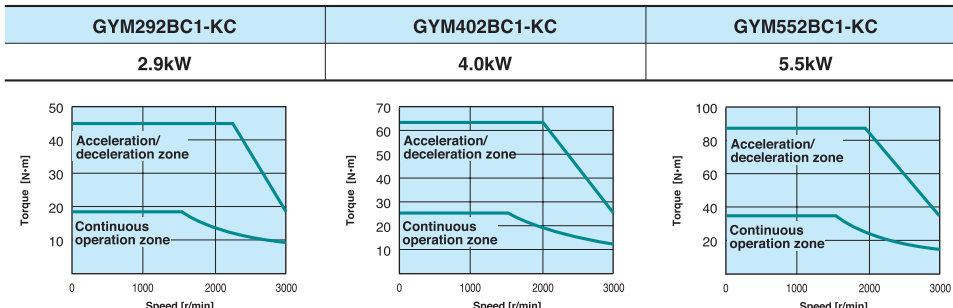

# External Dimensions

## Servo amplifier

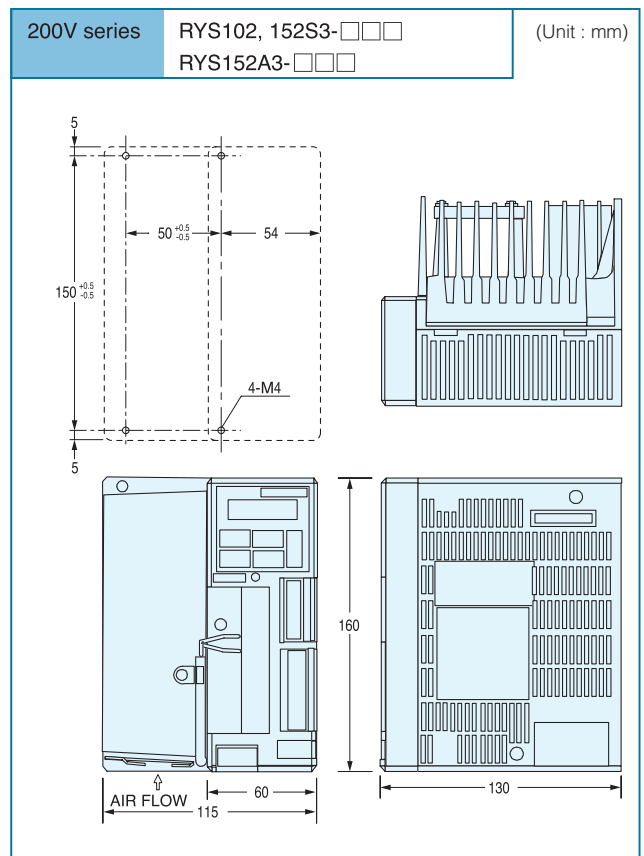
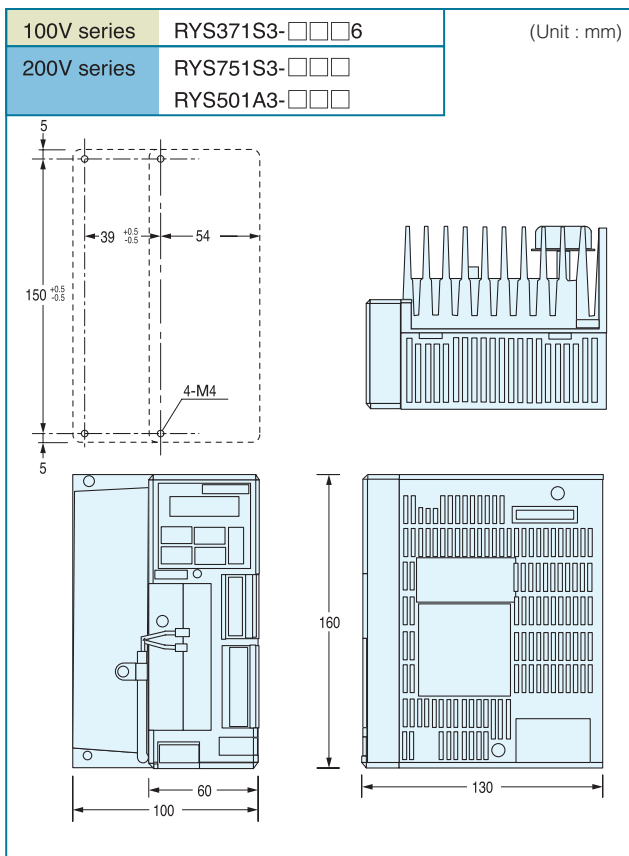
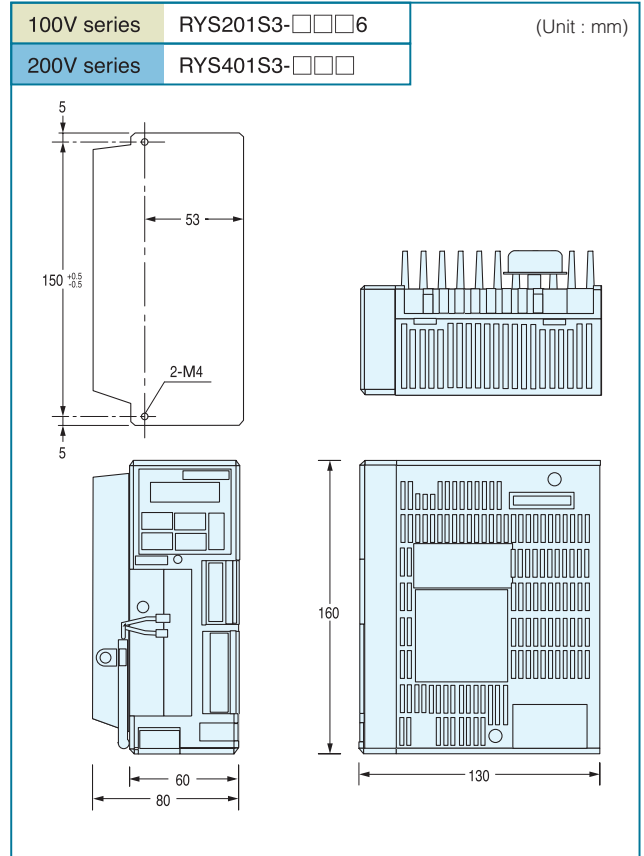
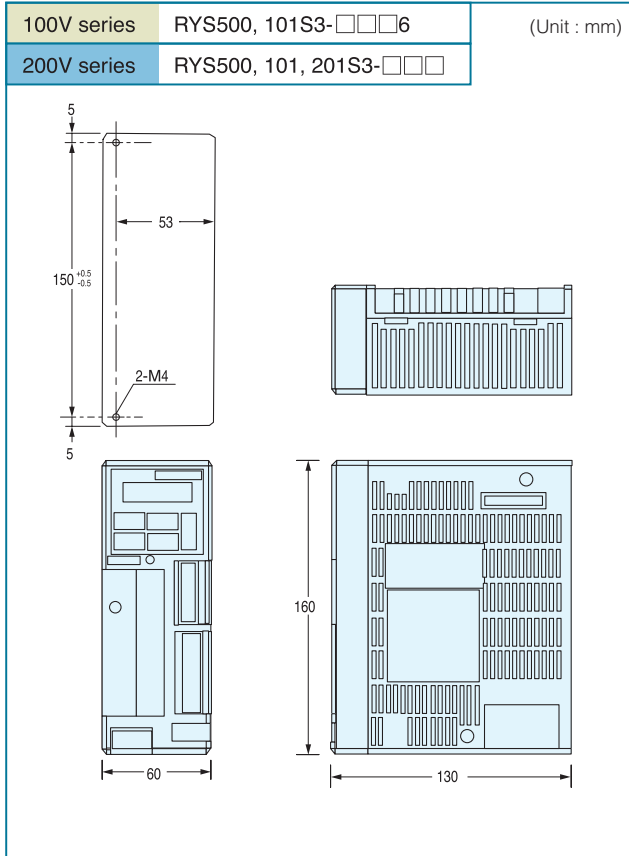

External Dimensions

Servo amplifier

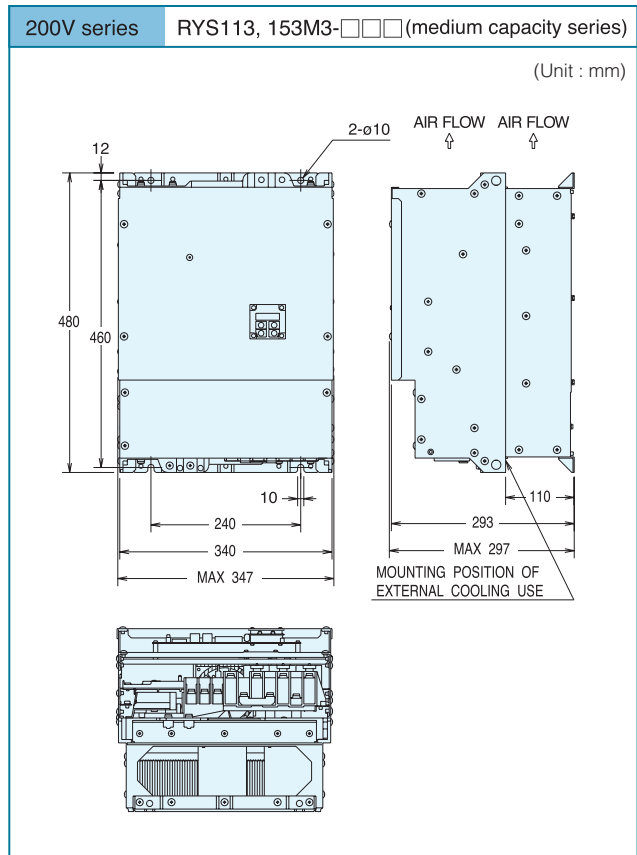
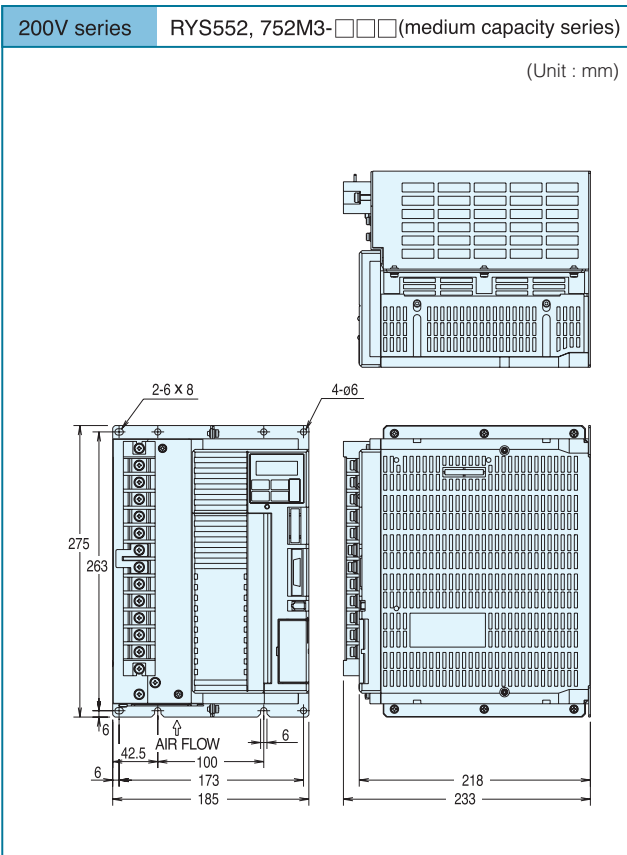
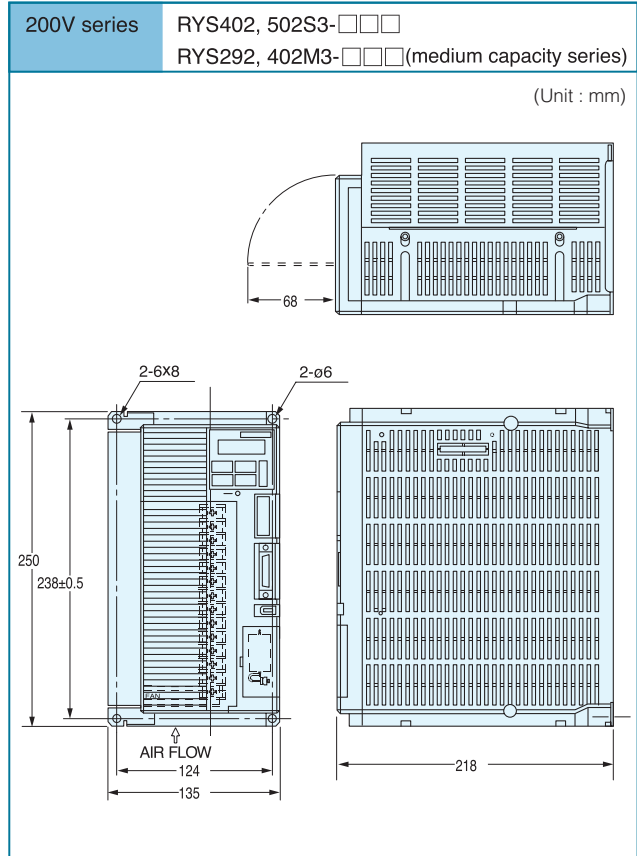
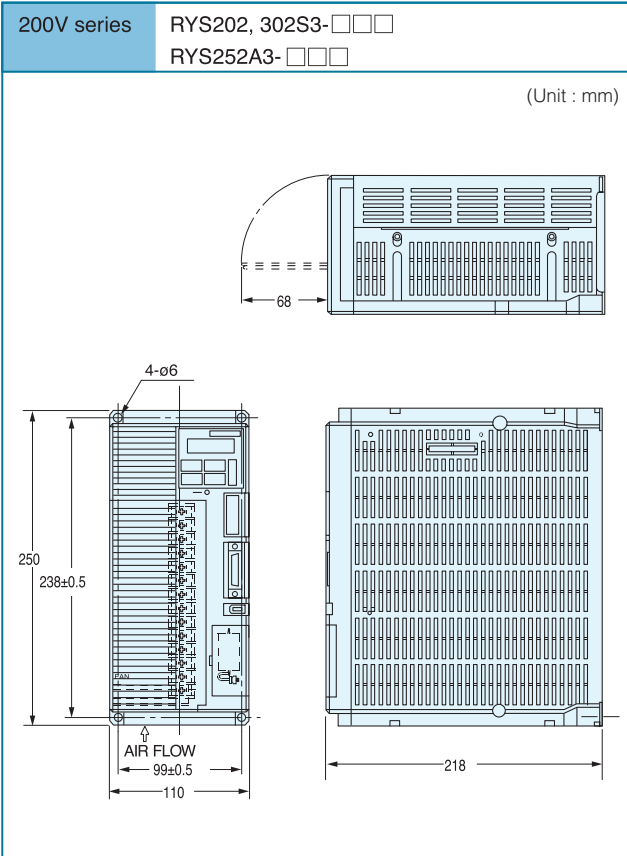

## GYS motor

### Standard type

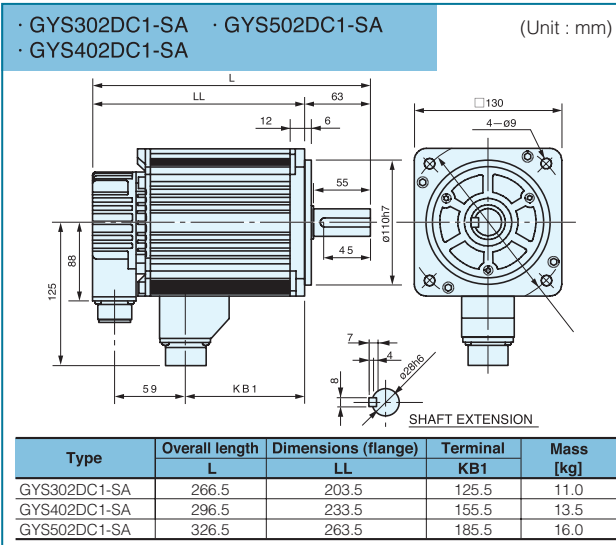
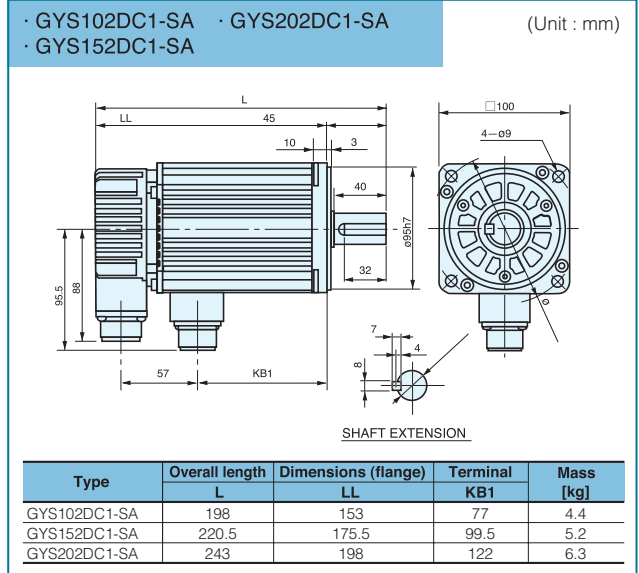
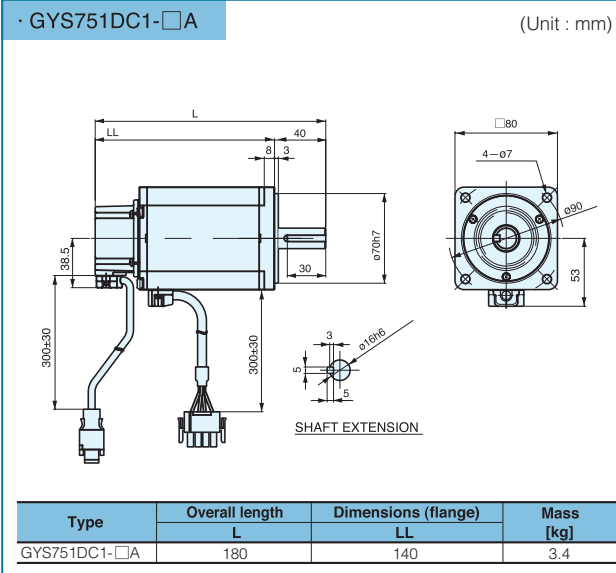
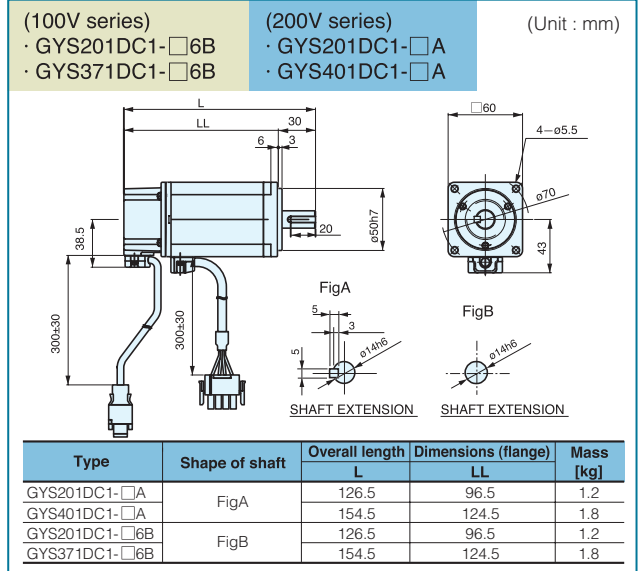
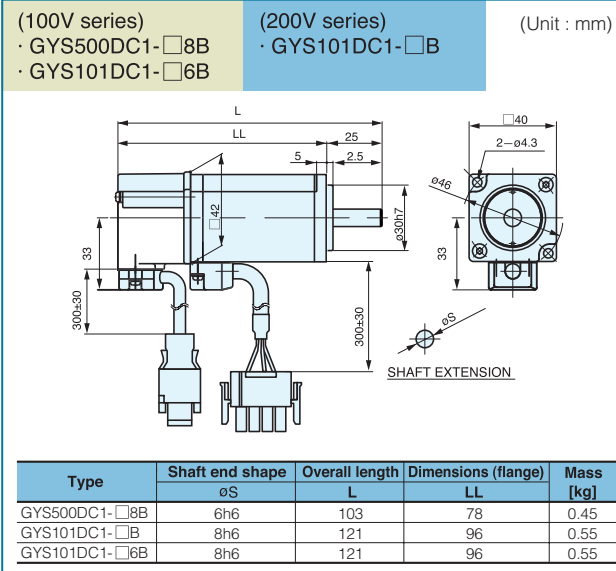

Note: □ in type is for "S" or "C".

External Dimensions

GYS motor

Motor with a brake

(100V series)  
 · GYS500DC1-□8B-B  
 · GYS101DC1-□6B-B

(200V series)  
 · GYS101DC1-B-B

(Unit : mm)

Type	Shaft end shape φS	Overall length L	Dimensions (flange)		Mass [kg]
			LL	LL	
GYS500DC1-□8B-B	6h6	140	115	0.62	
GYS101DC1-□B-B	8h6	158	133	0.72	
GYS101DC1-□6B-B	8h6	158	133	0.72	

(100V series)  
 · GYS201DC1-□6B-B  
 · GYS371DC1-□6B-B

(200V series)  
 · GYS201DC1-□A-B  
 · GYS401DC1-□A-B

(Unit : mm)

Type	Shape of shaft	Overall length		Dimensions (flange)		Mass [kg]
		L	LL	L	LL	
GYS201DC1-□A-B	FigA	164.5	134.5	1.7		
GYS401DC1-□A-B	FigA	192.5	162.5	2.3		
GYS201DC1-□6B-B	FigB	164.5	134.5	1.7		
GYS371DC1-□6B-B	FigB	192.5	162.5	2.3		

· GYS751DC1-□A-B

(Unit : mm)

Type	Overall length		Dimensions (flange)		Mass [kg]
	L	LL	L	LL	
GYS751DC1-□A-B	216	176	176	176	4.2

· GYS102DC1-SA-B · GYS202DC1-SA-B  
 · GYS152DC1-SA-B

(Unit : mm)

Type	Overall length		Terminal		Mass [kg]
	L	LL	KB1	KB1	
GYS102DC1-SA-B	239	194	79	5.9	
GYS152DC1-SA-B	261.5	216.5	101.5	6.8	
GYS202DC1-SA-B	284	239	124	7.9	

· GYS302DC1-SA-B · GYS502DC1-SA-B  
 · GYS402DC1-SA-B

(Unit : mm)

Type	Overall length		Terminal		Mass [kg]
	L	LL	KB1	KB1	
GYS302DC1-SA-B	308.5	245.5	127.5	13.0	
GYS402DC1-SA-B	338.5	275.5	157.5	15.5	
GYS502DC1-SA-B	368.5	305.5	187.5	18.0	

Note: □ in Type is for 'S' or 'C'.

## GYC motor

### Standard type

· GYC101DC1-□A

(Unit : mm)

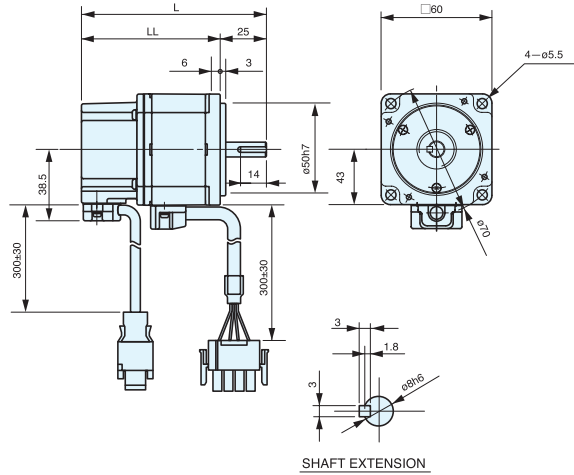

Type	Overall length	Dimensions (flange)	Mass [kg]
	L	LL	
GYC101DC1-□A	100	75	0.75

· GYC201DC1-□A  
· GYC401DC1-□A

(Unit : mm)

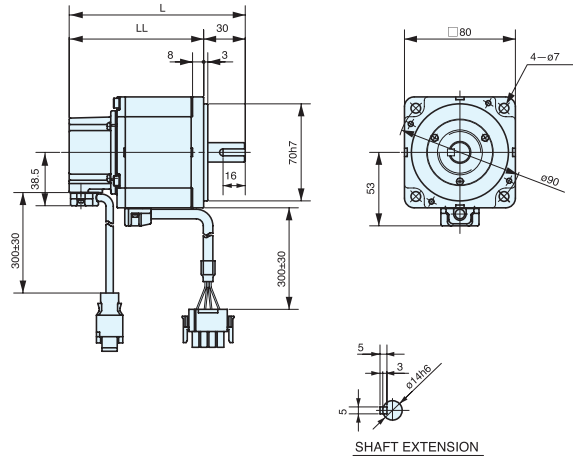

Type	Overall length	Dimensions (flange)	Mass [kg]
	L	LL	
GYC201DC1-□A	112	82	1.3
GYC401DC1-□A	127	97	1.9

· GYC751DC1-□A

(Unit : mm)

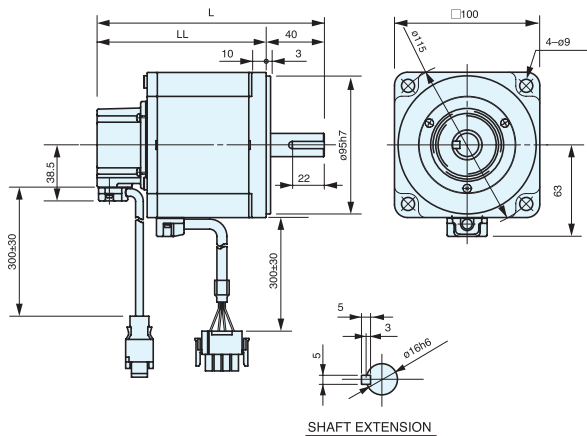

Type	Overall length	Dimensions (flange)	Mass [kg]
	L	LL	
GYC751DC1-□A	156.5	116.5	3.5

· GYC102DC1-SA · GYC202DC1-SA  
· GYC152DC1-SA

(Unit : mm)

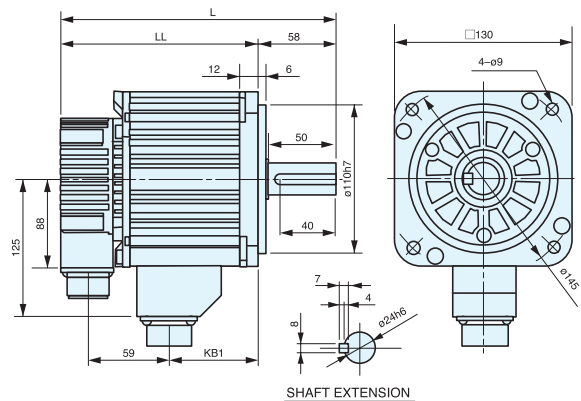

Type	Overall length	Dimensions (flange)	Terminal	Mass [kg]
	L	LL	KB1	
GYC102DC1-SA	201.5	143.5	65.5	5.7
GYC152DC1-SA	216.5	158.5	80.5	7.0
GYC202DC1-SA	231.5	173.5	95.5	8.2



GYA motor

· GYA501BC1-SA

(Unit : mm)

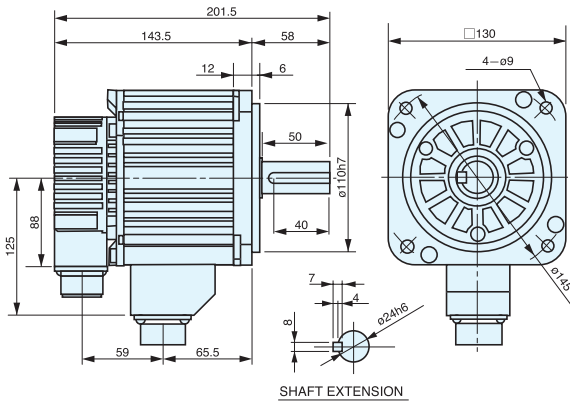

Mass : 5.7 [kg]

· GYA152BC1-SA

(Unit : mm)

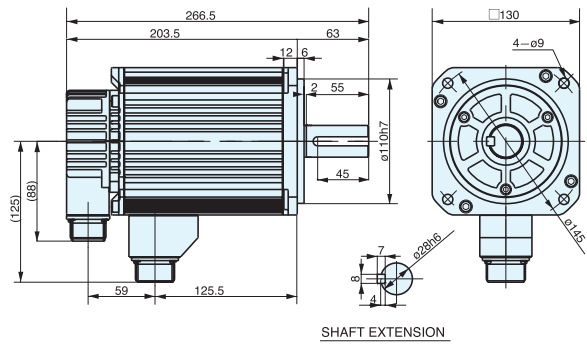

Mass : 11.0 [kg]

· GYA252BC1-SA

(Unit : mm)



Mass : 16.0 [kg]

External Dimensions

GYM motor

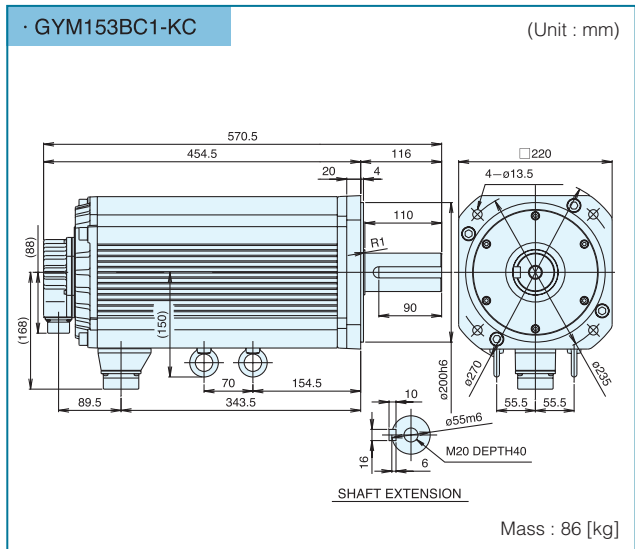
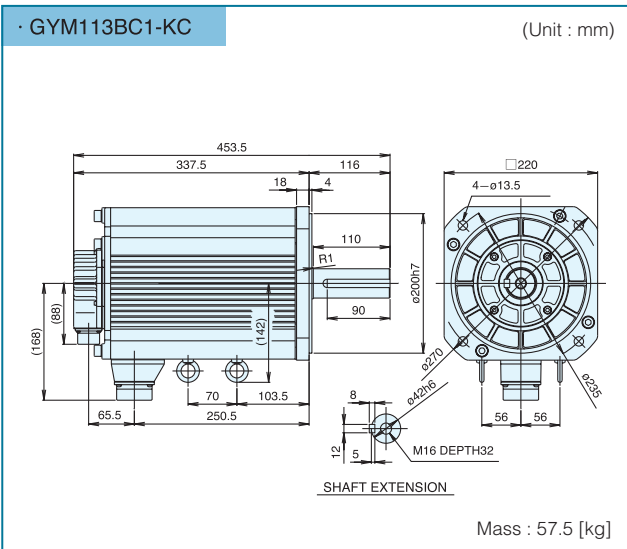
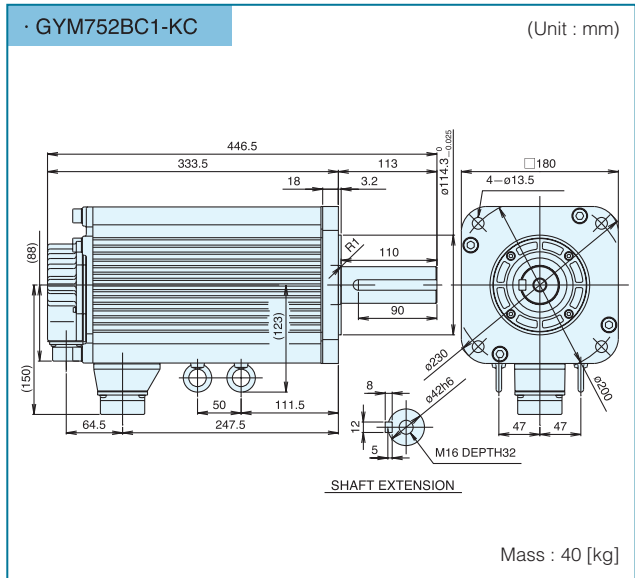
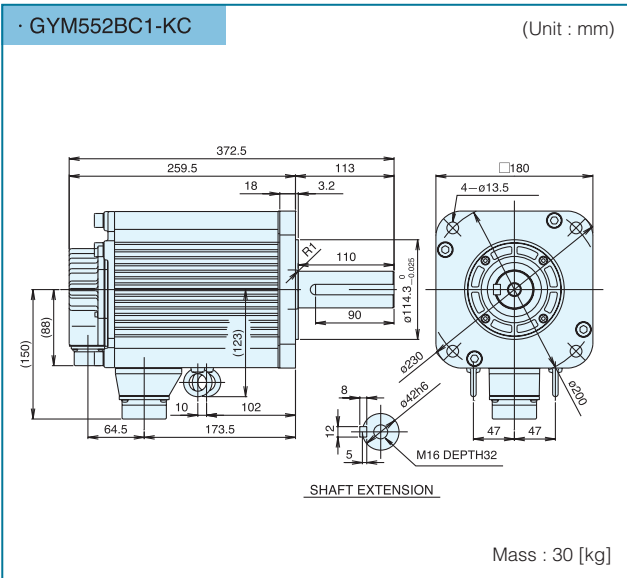
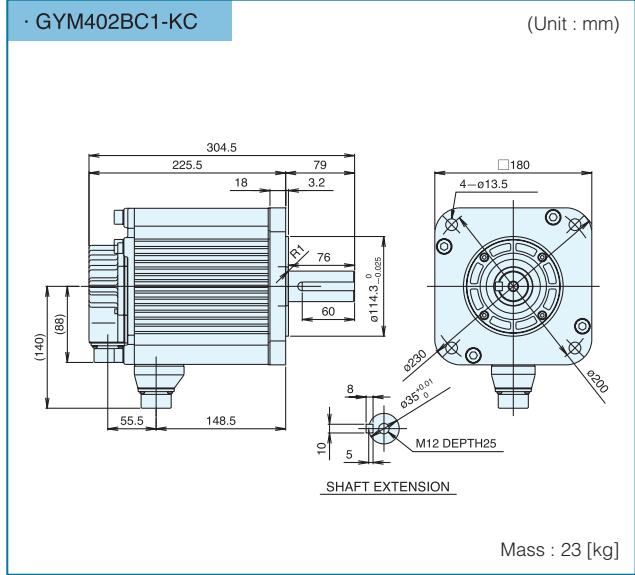
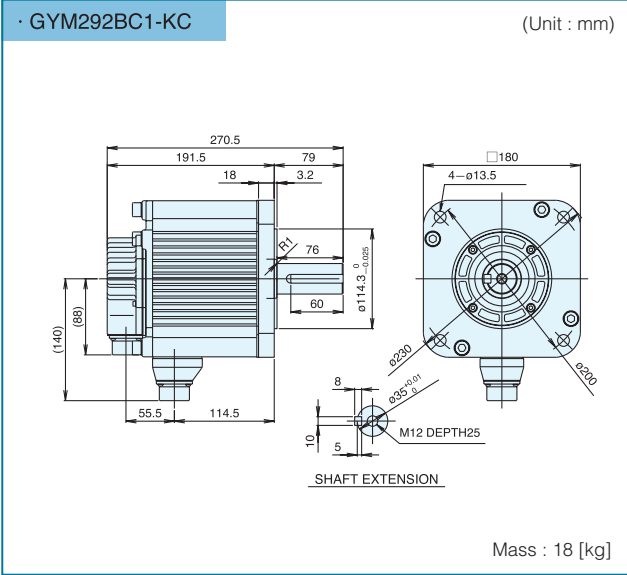

Option

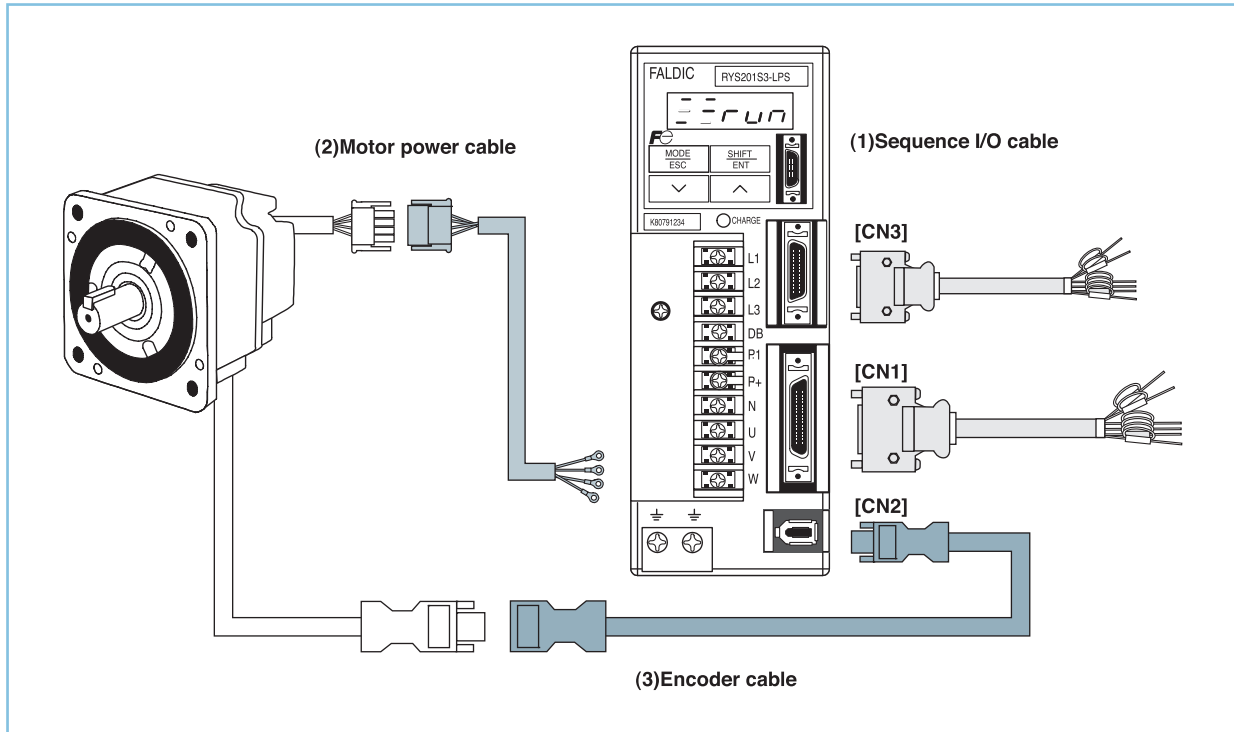

Name		Type	Applicable model	Remarks																																			
(1) Servo amplifier sequence I/O wiring	Cable	CN1	WSC-D36P03	<b>Support list</b> <table border="1"> <thead> <tr> <th rowspan="2">Cable type</th> <th>Amplifier interface</th> <th colspan="2">DI/DO</th> <th>SX bus</th> <th>T-link, RS-485</th> </tr> <tr> <th>Amplifier type</th> <th>V type</th> <th>L,R type</th> <th>V,L,R type</th> <th>L,R type</th> </tr> </thead> <tbody> <tr> <td>WSC-D36P03</td> <td></td> <td>○</td> <td>○</td> <td>—</td> <td>—</td> </tr> <tr> <td>WSC-D26P03</td> <td></td> <td>—</td> <td>—</td> <td>○</td> <td>○</td> </tr> <tr> <td>WSC-D20P03</td> <td></td> <td>—</td> <td>○</td> <td>—</td> <td>—</td> </tr> <tr> <td>NP1C-P3</td> <td></td> <td>—</td> <td>—</td> <td>○</td> <td>—</td> </tr> </tbody> </table>	Cable type	Amplifier interface	DI/DO		SX bus	T-link, RS-485	Amplifier type	V type	L,R type	V,L,R type	L,R type	WSC-D36P03		○	○	—	—	WSC-D26P03		—	—	○	○	WSC-D20P03		—	○	—	—	NP1C-P3		—	—	○	—
			Cable type			Amplifier interface	DI/DO		SX bus	T-link, RS-485																													
					Amplifier type	V type	L,R type	V,L,R type	L,R type																														
		WSC-D36P03			○	○	—	—																															
		WSC-D26P03			—	—	○	○																															
		WSC-D20P03			—	○	—	—																															
NP1C-P3		—	—	○	—																																		
WSC-D26P03																																							
WSC-D20P03																																							
CN3	WSC-D36P03		○	—	—																																		
	WSC-D26P03		—	—	○																																		
	WSC-D20P03		—	○	—																																		
(2) Servo motor power	Motor without a brake	Cable	WSC-M04P05	GYS motor: 0.75kW or less GYC motor: 0.75kW or less	Loose wires on an end																																		
		Connector	WSK-M04P-CA	GYS motor: 1.0 to 2.0kW	Please prepare the power cable for motors at left using the specified type connector. See page 36 for the connector of 5.5kW or higher GYM motor.																																		
			WSK-M04P-CB	GYS motor: 3.0 to 5.0kW GYC motor: 1.0 to 2.0kW GYA motor: 0.5, 1.5, 2.5kW GYM motor: 2.9 to 4.0kW																																			
	Motor with a brake	Cable	WSC-M06P05	GYS motor: 0.75kW or less GYC motor: 0.75kW or less	Loose wires on an end																																		
		Connector	WSK-M06P-CA	GYS motor: 1.0 to 2.0kW	Please prepare the power cable for motors at left using the specified type connector. See page 36 for the connector of 5.5kW or higher GYM motor.																																		
			WSK-M06P-CB	GYS motor: 3.0 to 5.0kW GYC motor: 1.0 to 2.0kW GYA motor: 0.5, 1.5, 2.5kW GYM motor: 2.9 to 4.0kW																																			
(3) Servo motor encoder wiring	Cable CN2	WSC-P06P05	GYS motor: 0.75kW or less GYC motor: 0.75kW or less	Connectors on both ends																																			
		WSC-P06P05-C	GYS motor: 1.0kW or more GYC motor: 1.0kW or more GYA motor: 0.5 to 2.5kW (for all models) GYM motor: 2.9 to 15kW (for all models)	Connectors on both ends																																			

Other options

Name	Type	Description	Remarks	
Control power input connector kit	WSK-L02P	Used to supply control power separately to the servo amplifier.	For servo amplifier (LC1, LC2)	
Battery (with connector)	WSB-S	Backup battery for ABS function	-	
External regenerative resistor (used when regenerative energy is high)	WSR-***	For FALDIC-α	-	
	DB**-2		-	
	DB***V-21B	For Medium capacity FALDIC-α	-	
PC Loader*	Converter for PC Loader	NW0H-CNV	RS-232C to RS-485 converter	Both converter and cable are required.
	Cable for PC Loader	NP4H-CB2	Interconnecting cable between the servo amplifier and converter	

\*You can download the PC Loader software from our web site.

<http://www.fujielectric.co.jp/fcs/>

Option/Peripheral Equipment

Peripheral equipment

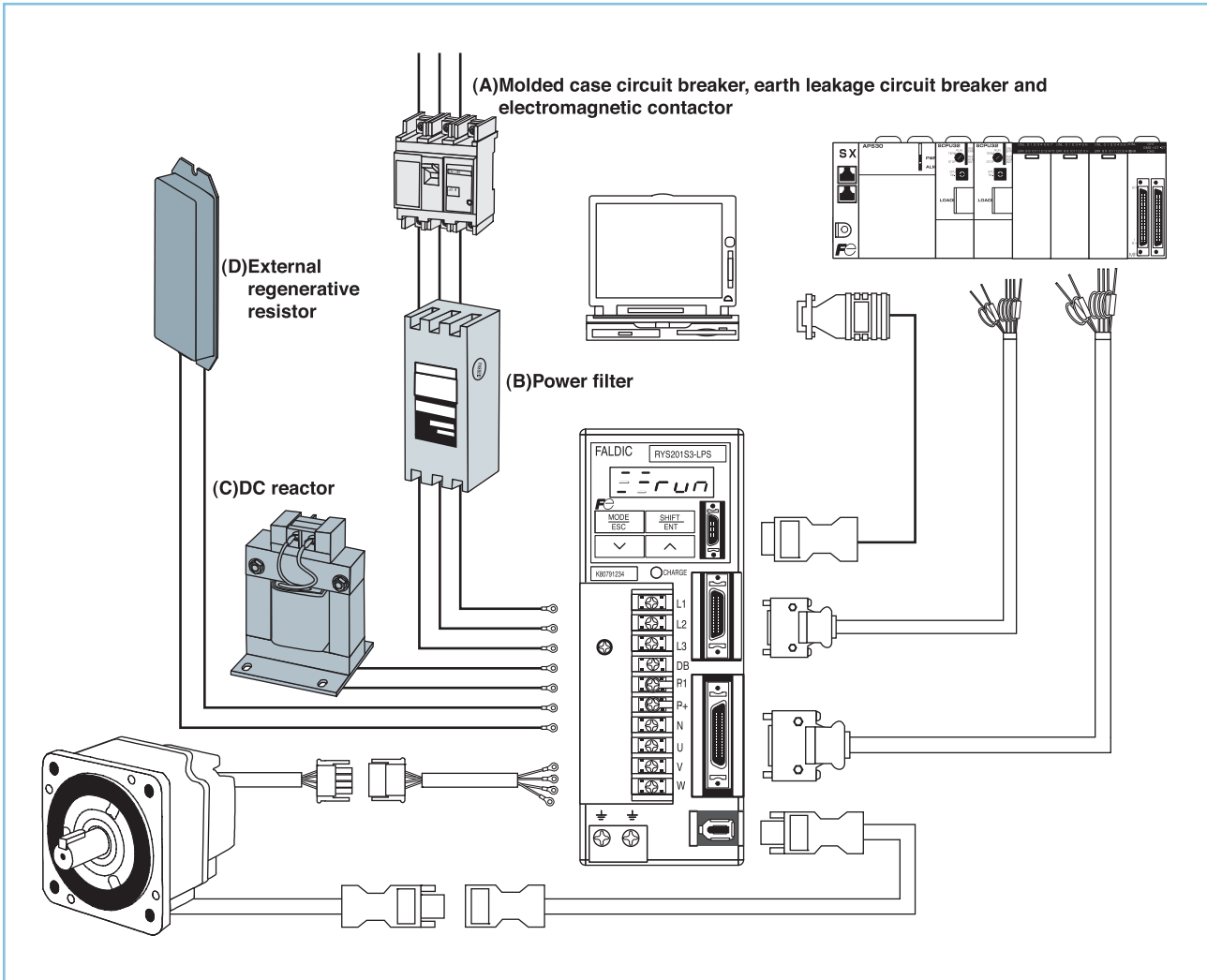

Input power	Servo amplifier type		Molded case circuit breaker	Earth leakage circuit breaker	Electromagnetic contactor	Surge absorber	Power filter	DC reactor	External regenerative resistor	
	Class		(A)	(B)	(C)		(D)			
3-phase 200V	$\alpha$ series amplifier	RYS500S3-□□□	EA33AC/3	EG33AC/3	SC-03	[For control relay] S1-B-0 Type: 200 $\Omega$ (1/2W) +0.1 $\mu$ F (made by Okaya Electric Industries)	RNFTC06-20	DCR2-0.2	WSR-401	
		RYS101S3-□□□						DCR2-0.4		
		RYS201S3-□□□						DCR2-0.75		
		RYS401S3-□□□	EA33AC/5	EG33AC/5			SC-4-1	RNFTC10-20	DCR2-1.5	WSR-751
		RYS751S3-□□□	EA33AC/10	EG33AC/10				RNFTC20-20	DCR2-2.2	WSR-152
		RYS102S3-□□□	EA33AC/15	EG33AC/15					DCR2-3.7	DB11-2
		RYS152S3-□□□	EA33AC/20	EG33AC/20			SC-N1	RNFTC30-20	DCR2-5.5	DB22-2
		RYS202S3-□□□	EA33AC/30	EG33AC/30				DCR2-11		
		RYS302S3-□□□	EA53AC/40	EG53AC/40			SC-N2	RNFTC50-20	DCR2-0.75	WSR-751
	RYS402S3-□□□	EA53AC/50	EG53AC/50	RNFTC06-20	DCR2-2.2			WSR-152		
	RYS502S3-□□□	EA53AC/50	EG53AC/50	RNFTC20-20	DCR2-3.7			DB11-2		
	Low-base series amplifier	RYS501A3-□□□	EA33AC/10	EG33AC/10	SC-03		RNFTC30-20	DCR2-5.5	DB5.5V-21B	
		RYS152A3-□□□	EA33AC/20	EG33AC/20	SC-4-1		RNFTC50-20	DCR2-7.5	DB7.5V-21B	
		RYS252A3-□□□	EA33AC/30	EG33AC/30	SC-N1		RNFTC60-20	DCR2-15	DB15V-21B	
		RYS292M3-□□□	EA53AC/40	EG53AC/40	SC-N2S		RNFMC1H-20	DCR2-18.5	DB18.5V-21B	
RYS402M3-□□□		EA53AC/50	EG53AC/50	SC-N2		DCR2-22	DB22V-21B			
RYS552M3-□□□		EA53AC/50	EG53AC/50	SC-N2						
Medium capacity $\alpha$ series amplifier	RYS752M3-□□□	EA103C/75	EG103C/75	SC-N2S						
	RYS113M3-□□□	EA103C/100	EG103C/100	SC-N3						
	RYS153M3-□□□	EA203B/125	EG203B/125	SC-N4						
Single-phase 100V	$\alpha$ series amplifier	RYS500S3-□□□6	EA32AC/3	EG32AC/3	SC-03	[For electromagnetic contactor] S2-A-0 Type: 500 $\Omega$ (1/2W) +0.2 $\mu$ F (made by Okaya Electric Industries)	RNFTC06-20	DCR2-0.2	WSR-401	
		RYS101S3-□□□6	EA32AC/5	EG32AC/5			DCR2-0.4			
		RYS201S3-□□□6	EA32AC/10	EG32AC/10			DCR2-0.75			
		RYS371S3-VVX6	EA32AC/15	EG32AC/15			SC-0	RNFTC20-20	DCR2-1.5	WSR-751

Peripheral equipment

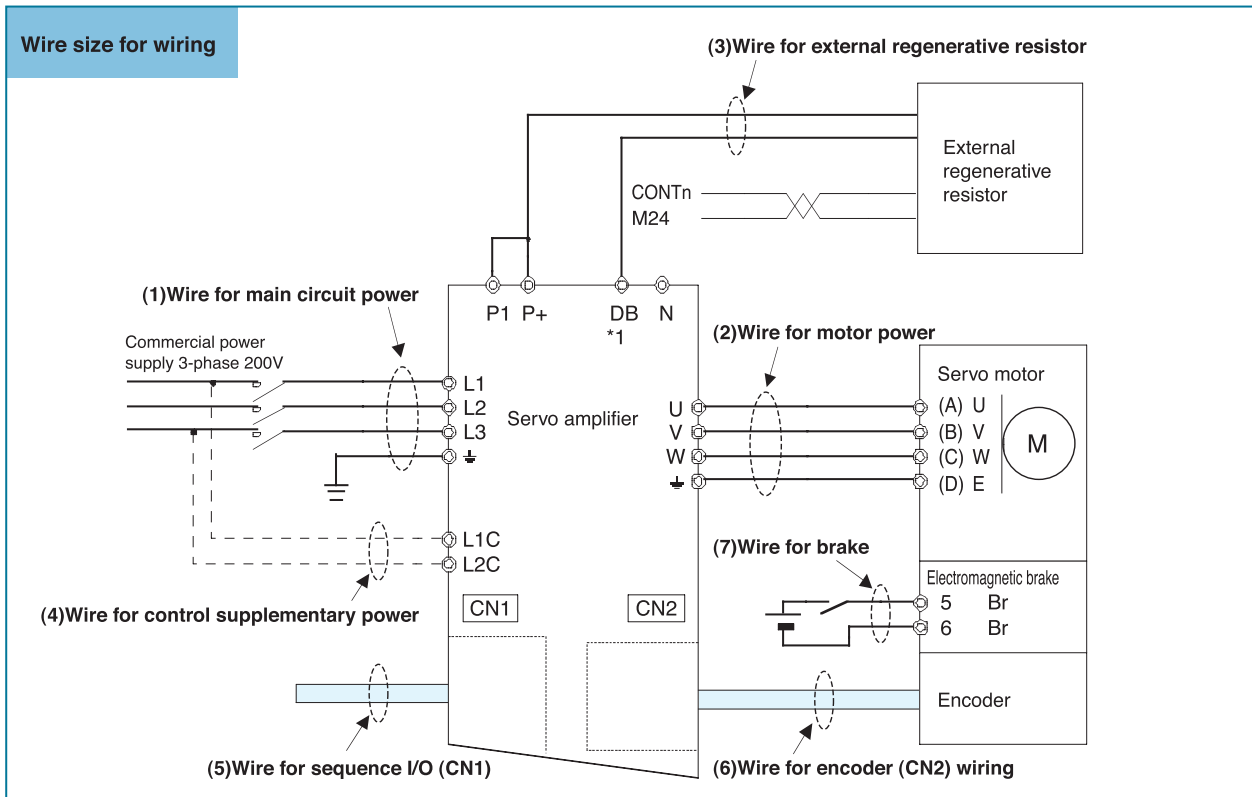

\*1)The name of the DB pin depends on the capacity.

Input power	Servo amplifier type	(1)Main circuit (L1,L2,L3,±) (2)Motor power (U,V,W) (Unit: mm <sup>2</sup> )	(3)External regenerative resistor (P+,DB) (Unit: mm <sup>2</sup> )	(4) Supplementary power for control (Unit: mm <sup>2</sup> )	(5) Sequence I/O (Unit: mm <sup>2</sup> )	(6)Encoder	(7)Brake (Unit: mm <sup>2</sup> )	
3-phase 200V	α series amplifier	RYS500S3-□□□□	1.25	0.75	AWG#26	Bridging polyethylene for moving robot Vinyl sheathed cable (flame-retardant type) RMCV-SB AWG#25/2P+AWG#23/2C(10m or below) AWG#25/2P+AWG#17/2C(50m or below) Made by Daiden Co., Ltd.	1.25	
		RYS101S3-□□□□						
		RYS201S3-□□□□						
		RYS401S3-□□□□						
		RYS751S3-□□□□						
		RYS102S3-□□□□						
	RYS152S3-□□□□	2.0						
	RYS202S3-□□□□							
	RYS302S3-□□□□	3.5						
	RYS402S3-□□□□							
	RYS502S3-□□□□	Low-base series amplifier	RYS501A3-□□□□				1.25	-
	RYS152A3-□□□□							
RYS252A3-□□□□	2.0							
Medium capacity α series amplifier	RYS292M3-□□□□		3.5	1.25				
	RYS402M3-□□□□		8.0					
	RYS552M3-□□□□							
	RYS752M3-□□□□	14.0	2.0					
	RYS113M3-□□□□	22.0	3.5					
RYS153M3-□□□□								
Single-phase 100V	α series amplifier	RYS500S3-□□□□6	1.25	1.25	-	1.25		
		RYS101S3-□□□□6						
		RYS201S3-□□□□6						
		RYS371S3-VVX6						

\* Selection of wire sizes above is based on 75°C (HIV) wires. To use other wires, please refer to the users manual.

Option/Peripheral Equipment

External dimensions of options

**Series** : Cable for sequence input/output  
**Type** : WSC-D20P03  
**Applicable amplifier** : CN3 of RYS□□□S3-LPS,LPK,RPS

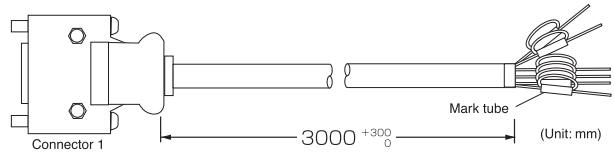

Connector 1	
Plug	10120-3000PE
Shell	10326-52AO-008

Connector 1		1	2	3	4	5	6	7	8	9	10	11	12	13	14	15	16	17	18	19	20
Mark tube		1	2	3	4	5	6	7	8	9	10	11	12	13	14	15	16	17	18	19	20
Wire color	Color	Orange	Gray	White	Yellow	Pink	Orange	Gray	White	Yellow	Pink	Orange	Gray	White	Yellow	Pink	Orange	Gray	White	Yellow	Pink
	Mark	Red 1	Black 1	Red 1	Black 1	Red 1	Black 1	Red 2	Black 2	Red 2	Black 2	Red 2	Black 2	Red 2	Black 2	Red 2	Black 2	Red 2	Black 2	Red 2	Black 2

Maker: Sumitomo 3M

**Series** : Cable for sequence input/output  
**Type** : WSC-D26P03  
**Applicable amplifier** : CN1 of RYS□□□S3-VSS,VSK,LSS,LSK,RSS,LTS,RTS,LRS

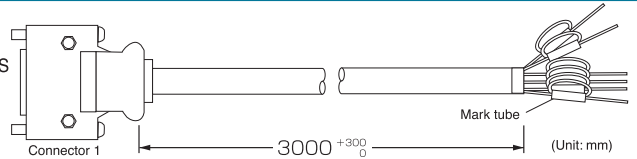

Connector 1	
Plug	10126-3000PE
Shell	10326-52AO-008

Connector 1		1	2	3	4	5	6	7	8	9	10	11	12	13	14	15	16	17	18	19	20	21	22	23	24	25	26		
Mark tube		1	2	3	4	5	6	7	8	9	10	11	12	13	14	15	16	17	18	19	20	21	22	23	24	25	26		
Wire color	Color	Orange	Gray	White	Yellow	Pink	Orange	Gray	White	Yellow	Pink	Orange	Gray	White	Yellow	Pink	Orange	Gray	White	Yellow	Pink	Orange	Gray	White	Yellow	Pink	Orange	Gray	White
	Mark	Red 1	Black 1	Red 1	Black 1	Red 1	Black 1	Red 2	Black 2	Red 2	Black 2	Red 2	Black 2	Red 2	Black 2	Red 2	Black 2	Red 2	Black 2	Red 2	Black 2	Red 3	Black 3	Red 3	Black 3	Red 3	Black 3	Red 3	Black 3

Maker: Sumitomo 3M

**Series** : Cable for sequence input/output  
**Type** : WSC-D36P03  
**Applicable amplifier** : CN1 of RYS□□□S3-VVS,VVK,LPS,LPK,RPS

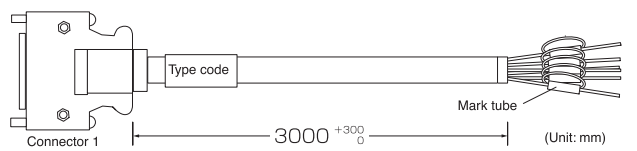

Connector 1	
Plug	10136-3000PE
Shell	10336-52AO-008

Connector 1		1	2	3	4	5	6	7	8	9	10	11	12	13	14	15	16	17	18	19	20	21	22	23	24	25	26	27	28	29	30	31	32	33	34	35	36		
Mark tube		1	2	3	4	5	6	7	8	9	10	11	12	13	14	15	16	17	18	19	20	21	22	23	24	25	26	27	28	29	30	31	32	33	34	35	36		
Wire color	Color	Orange	Gray	White	Yellow	Pink	Orange	Gray	White	Yellow	Pink	Orange	Gray	White	Yellow	Pink	Orange	Gray	White	Yellow	Pink	Orange	Gray	White	Yellow	Pink	Orange	Gray	White	Yellow	Pink	Orange	Gray	White	Yellow	Pink	Orange	Gray	White
	Mark	Red 1	Black 1	Red 1	Black 1	Red 1	Black 1	Red 2	Black 2	Red 2	Black 2	Red 2	Black 2	Red 2	Black 2	Red 2	Black 2	Red 2	Black 2	Red 2	Black 2	Red 3	Black 3	Red 3	Black 3	Red 3	Black 3	Red 3	Black 3	Red 4	Black 4	Red 4	Black 4	Red 4	Black 4	Red 4	Black 4		

Maker: Sumitomo 3M

**Series** : Servo motor encoder cable  
**Type** : WSC-P06P05 to WSC-P06P20  
**Applicable amplifier** : GYS,GYC:0.75kW or less

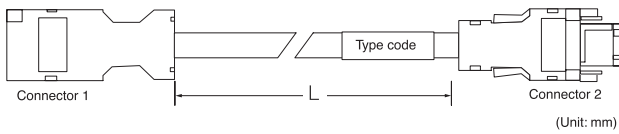

Type	L
WSC-P06P05	5000 <sup>+500</sup> / <sub>0</sub>
WSC-P06P10	10000 <sup>+1000</sup> / <sub>0</sub>
WSC-P06P20	20000 <sup>+2000</sup> / <sub>0</sub>

Connector 1		1	2	3	4	5	6	
Connector 2		1	2	3	4	5	6	
Wire color	Color	White	Black	Yellow	Orange	Brown	Red	Blue
	Mark	Red	Black	Yellow	Orange	White	Light blue	Light blue/White

Connector 1	
Socket housing	53988-0619
Socket shell body cover	58302-0628
Socket mold cover(A)	53989-0605
Socket mold cover(B)	53990-0605
Cable clamp	58303-0000
Clamp screw	59832-0009

Connector 2	
Plug housing	54180-0619
Plug shell body cover	58299-0626
Plug shell body	58300-0626
Plug mold cover (A)	54181-0615
Plug mold cover (B)	54182-0605
Cable clamp	58303-0000
Clamp screw	59832-0009

Maker: Molex Japan

Maker: Molex Japan

\* The types of connectors 1 and 2 are different from those in the connector kit.

**Series** : Servo motor encoder cable  
**Type** : WSC-P06P05-C to WSC-P06P20-C  
**Applicable amplifier** : GYS,GYC:1.0kW or more, GYA,GYM: all models

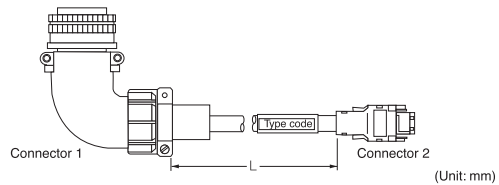

Type	L
WSC-P06P05-C	5000 <sup>+500</sup> / <sub>0</sub>
WSC-P06P10-C	10000 <sup>+1000</sup> / <sub>0</sub>
WSC-P06P20-C	20000 <sup>+2000</sup> / <sub>0</sub>

Connector 1		H	G	T	S	C	D	
Connector 2		1	2	3	4	5	6	
Wire color	Color	White	Black	Yellow	Orange	Brown	Red	Blue
	Mark	Red	Black	Yellow	Orange	White	Light blue	Light blue/White

Connector 1	
L-type plug	MS3108B20-29S
Cable clamp	MS3057-12A

Made by Daiichi Denshi Kogyo

Connector 2	
Plug housing	54180-0619
Plug shell body cover	58299-0626
Plug shell body	58300-0626
Plug mold cover (A)	54181-0615
Plug mold cover (B)	54182-0605
Cable clamp	58303-0000
Clamp screw	59832-0009

Maker: Molex Japan

External dimensions of options

**Series** : Servo motor encoder cable  
**Type** : WSC-P06P05-W to WSC-P06P20-W  
**Applicable amplifier** : All models of  $\alpha$  series (combined with either of WSK-P06P-F or WSK-P06P-C)

Type	L
WSC-P06P05-W	5000 <sup>+500</sup> / <sub>0</sub>
WSC-P06P10-W	10000 <sup>+1000</sup> / <sub>0</sub>
WSC-P06P20-W	20000 <sup>+2000</sup> / <sub>0</sub>

Mark tube indication	P5	M5	BAT+	BAT-	SIG+	SIG-
Connector 2	1	2	3	4	5	6
Wire color	Red	Black	Orange	White	Light blue	Light blue/White
	White	Black	Yellow/Brown	Red	Blue	

The wire without mark tube is a shield wire.

Connector 2	
Plug housing	54180-0619
Plug shell body cover	58299-0626
Plug shell body	58300-0626
Plug mold cover (A)	54181-0615
Plug mold cover (B)	54182-0605
Cable clamp	58303-0000
Clamp screw	59832-0009

Maker: Molex Japan

**Series** : Servo motor power wiring optional cable  
**Type** : WSC-P04P05 to WSC-P04P20  
**Applicable amplifier** : GYS,GYC:0.75kW or less

Type	L
WSC-M04P05	5000 <sup>+500</sup> / <sub>0</sub>
WSC-M04P10	10000 <sup>+1000</sup> / <sub>0</sub>
WSC-M04P20	20000 <sup>+2000</sup> / <sub>0</sub>

Connector 1	
Cap housing	350780-1
Socket	350570-3

Maker: Tyco electronics AMP

Connector 1	
Mark	1 2 3 4
Wire color	Red White Black Green/Yellow

**Series** : Servo motor power cable  
**Type** : WSC-P06P05 to WSC-P06P20  
**Applicable amplifier** : GYS,GYC:0.75kW or less (with a brake)

Type	L
WSC-M06P05	5000 <sup>+500</sup> / <sub>0</sub>
WSC-M06P10	10000 <sup>+1000</sup> / <sub>0</sub>
WSC-M06P20	20000 <sup>+2000</sup> / <sub>0</sub>

Connector 1	
Cap housing	350781-1
Socket	350570-3

Maker: Tyco electronics AMP

Connector 1	
Mark	1 2 3 4 5 6
Wire color	Red White Black Green/Yellow Red Black

**Series** : Encoder wiring connector kit  
**Type** : WSK-P06P-M  
**Applicable amplifier** : All models (amplifier side)

Plug housing	54180-0619
Plug shell body cover	58299-0626
Plug shell body	58300-0626
Plug mold cover (A)	54181-0615
Plug mold cover (B)	54182-0605
Cable clamp	58303-0000
Clamps crew	59832-0009

Maker: Molex Japan

**Series** : Sequence I/O connector kit (extended I/O for L/R type)  
**Type** : WSK-D20P  
**Applicable amplifier** : CN3 of RYS□□□S3-LPS,LPK,RPS

Soldered plug	10120-3000PE
Shell kit	10320-52A0-008

Maker: Sumitomo 3M

**Series** : Sequence I/O connector kit(SX bus connected type)  
**Type** : WSK-D26P  
**Applicable amplifier** : CN1 of RYS□□□3-VSS,VSK,LSS LSK,RSS,LTS,RTS,LRS

Soldered plug	10126-3000PE
Shell kit	10326-52A0-008

Maker: Sumitomo 3M

**Series** : Sequence I/O connector kit  
**Type** : WSK-D36P  
**Applicable amplifier** : CN1 of RYS□□□S3-VVS,VVK,LPS,LPK,RPS

Soldered plug	10136-3000PE
Shell kit	10336-52A0-008

Maker: Sumitomo 3M The connector type is different from that of the optional cable.

**Series** : Connector kit for encoder wiring  
**Type** : WSK-P06P-F  
**Applicable amplifier** : GYS,GYC:0.75kW or less (motor side)

Socket housing	53988-0619
Socket shell body cover	58302-0628
Socket mold cover (A)	53989-0605
Socket mold cover (B)	53990-0605
Cable clamp	58303-0000
Clamp screw	59832-0009

Maker: Molex Japan



CAUTION

When using the encoder wiring connector kit for wiring, be sure to follow the connection diagram and description in the "users manual".

Option/Peripheral Equipment

External dimensions of options

**Series** : Connector kit for encoder wiring  
**Type** : WSK-P06P-C  
**Applicable amplifier** : GYS,GYC:1.0kW or more (motor side),  
 GYA,GYM:all models

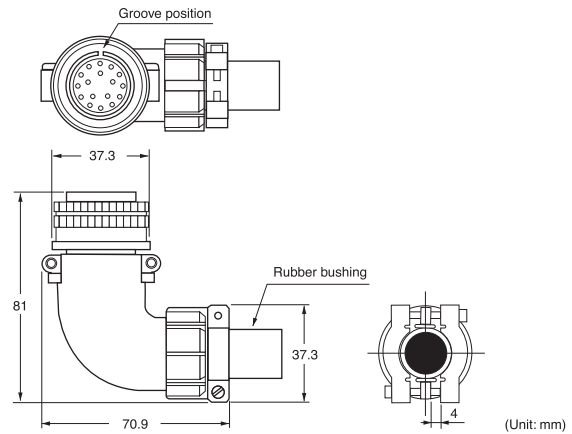

<b>L-shape plug</b>	MS3108B20-29S
<b>Cable clamp</b>	MS3057-12A

Maker: Daiichi Denshi Kogyo

**Series** : Servo motor power wiring connector kit  
**Type** : WSK-M04P  
**Applicable amplifier** : GYS,GYC:0.75kW or less

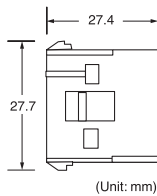

<b>Cap housing</b>	350780-1
<b>Shell body clamped side</b>	350689-3

Maker: Tyco electronics AMP

**Series** : Servo motor power wiring connector kit  
**Type** : WSK-M06P  
**Applicable amplifier** : GYS,GYC:0.75kW or less (with a brake)

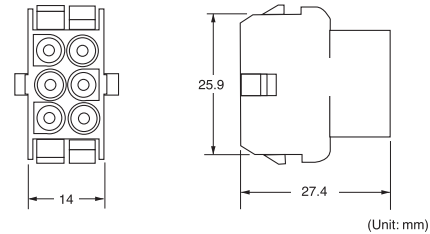

<b>Cap housing</b>	350781-1
<b>Shell body clamped side</b>	350689-3

Maker: Tyco electronics AMP

**Series** : Servo motor power wiring connector kit  
**Type** : WSK-M04P-CA  
**Applicable amplifier** : GYS:1.0kW to 2.0kW

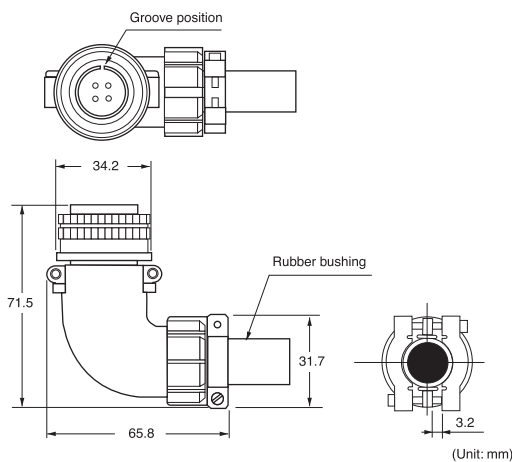

<b>L-shape plug</b>	MS3108B18-10S
<b>Cable clamp</b>	MS3057-10A

Maker: Daiichi Denshi Kogyo

**Series** : Servo motor power wiring connector kit  
**Type** : WSK-M04P-CB  
**Applicable amplifier** : GYS:3.0kW to 5.0kW, GYC:1.0kW to 2.0kW,  
 GYA:all models, GYM:2.9kW to 4.0kW

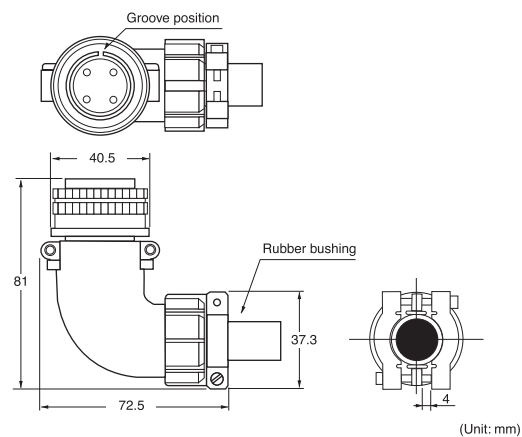

<b>L-shape plug</b>	MS3108B22-22S
<b>Cable clamp</b>	MS3057-12A

Maker: Daiichi Denshi Kogyo



**When using the encoder wiring connector kit for wiring, be sure to follow the connection diagram and description in the "users manual".**

External dimensions of options

**Series** : Servo motor power wiring connector kit  
**Type** : WSK-M06P-CA  
**Applicable amplifier** : GYS:1.0kW to 2.0kW (with a brake)

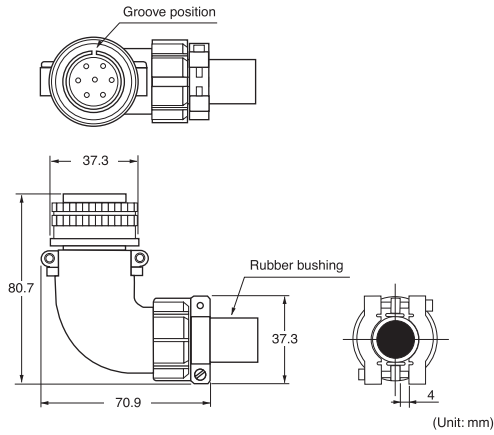

**L-shape plug** MS3108B20-15S

**Cable clamp** MS3057-12A

Maker: Daiichi Denshi Kogyo

**Series** : Servo motor power wiring connector kit  
**Type** : WSK-M06P-CB  
**Applicable amplifier** : GYS:3.0kW to 5.0kW, GYC:1.0kW to 2.0kW, GYA:all models, GYM:2.9kW to 4.0kW (with a brake)

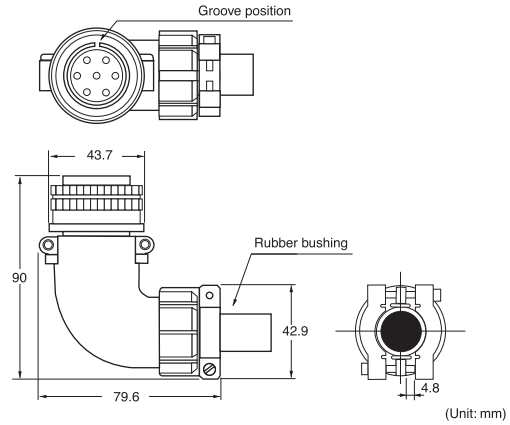

**L-shape plug** MS3108B24-10S

**Cable clamp** MS3057-16A

Maker: Daiichi Denshi Kogyo

**Series** : Control power connecting connector kit  
**Type** : WSK-L02P  
**Applicable amplifier** : Models of 1.5kW or less

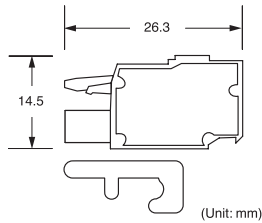

**Connector** 231-702/026-000

**Operation lever** 231-131

Maker: WAGO

**Series** : Battery  
**Type** : WSB-S  
**Applicable amplifier** : All models

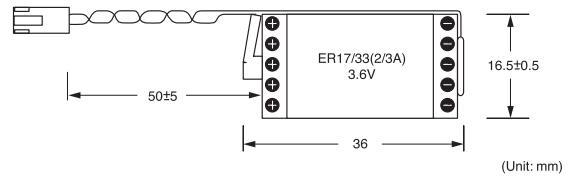

**Storage battery** ER17/33WK41 1PP

Maker: Hitachi Maxell

**Series** : Cable with PC Loader converter  
**Type** : NP4H-CB2  
**Applicable amplifier** : All models

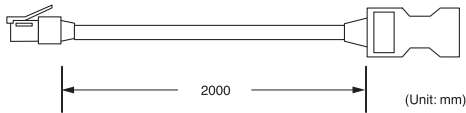

**Series** : SX bus expansion cable  
**Type** : NP1C-P3  
**Applicable amplifier** : All models

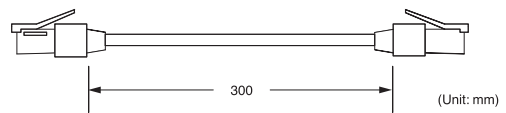

Option/Peripheral Equipment

External dimensions of options

**Series** : External regenerative resistor  
**Type** : WSR-401  
**Applicable amplifier** : RYS:0.4kW or less

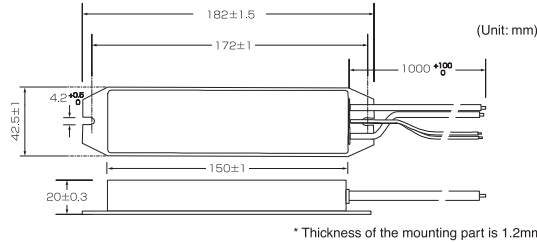

Item	Specifications	
<b>Type</b>	WSR-401	
<b>Resistor</b>	<b>Resistance</b>	68Ω
	<b>Allowable power</b>	17 W (continuous)
	<b>Working temperature</b>	Open at 135±10 [°C]
<b>Thermistor</b>	<b>Withstand voltage</b>	1.5 kV AC for 1 min
	<b>Contact capacity</b>	DC30 [V] 3 [A]

**Series** : External regenerative resistor  
**Type** : WSR-751  
**Applicable amplifier** : RYS:0.75kW

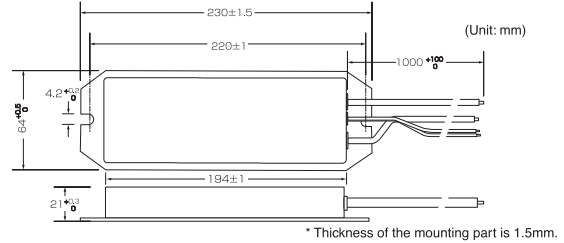

Item	Specifications	
<b>Type</b>	WSR-751	
<b>Resistor</b>	<b>Resistance</b>	15Ω
	<b>Allowable power</b>	25 W (continuous)
	<b>Working temperature</b>	Open at 135±10 [°C]
<b>Thermistor</b>	<b>Withstand voltage</b>	1.5 kV AC for 1 min
	<b>Contact capacity</b>	DC30 [V] 3 [A]

**Series** : External regenerative resistor  
**Type** : WSR-152  
**Applicable amplifier** : RYS:1.0kW to 1.5kW

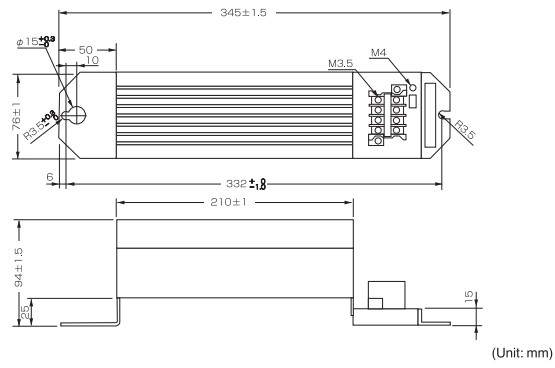

Item	Specifications	
<b>Type</b>	WSR-152	
<b>Resistor</b>	<b>Resistance</b>	15Ω
	<b>Allowable power</b>	50W (continuous)
	<b>Working temperature</b>	Open at 150±10 [°C]
<b>Thermistor</b>	<b>Withstand voltage</b>	2.5 kV AC for 1 min
	<b>Contact capacity</b>	DC30 [V] 3 [A]

**Series** : External regenerative resistor  
**Type** : DB11-2  
**Applicable amplifier** : RYS:2.0kW to 3.0kW

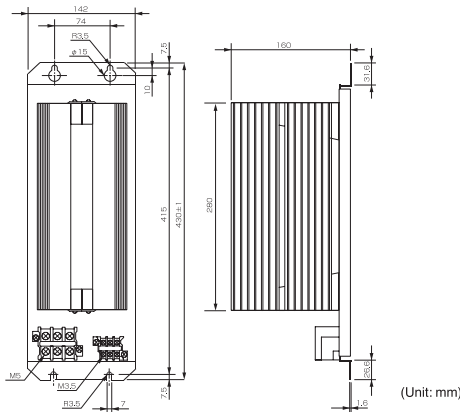

Item	Specifications	
<b>Type</b>	DB11-2	
<b>Resistor</b>	<b>Resistance</b>	10Ω
	<b>Allowable power</b>	260W (continuous)
	<b>Working temperature</b>	Open at 150±10 [°C]
<b>Thermistor</b>	<b>Withstand voltage</b>	2.5 kV AC for 1 min
	<b>Contact capacity</b>	AC120 [V] 0.1 [A]/DC30 [V] 0.1[A]

**Series** : External regenerative resistor  
**Type** : DB22-2  
**Applicable amplifier** : RYS:4.0kW to 5.0kW

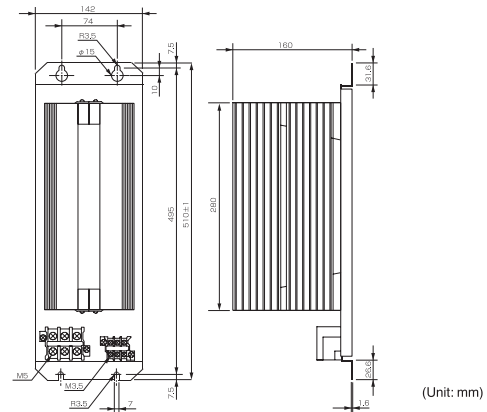

Item	Specifications	
<b>Type</b>	DB22-2	
<b>Resistor</b>	<b>Resistance</b>	5.8Ω
	<b>Allowable power</b>	300W (continuous)
	<b>Working temperature</b>	Open at 150±10 [°C]
<b>Thermistor</b>	<b>Withstand voltage</b>	2.5 kV AC for 1 min
	<b>Contact capacity</b>	AC120 [V] 0.1 [A]/DC30 [V] 0.1[A]

External dimensions of options

**Series** : External regenerative resistor  
**Type** : DB5.5V-21B  
**Applicable amplifier** : RYS (medium capacity):2.9kW

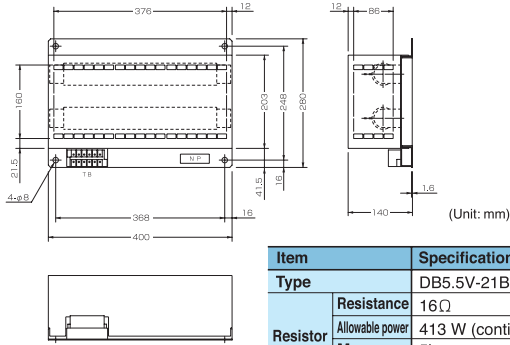

Item	Specifications	
Type	DB5.5V-21B	
Resistor	Resistance	16Ω
	Allowable power	413 W (continuous)
	Mass	5kg
	Screw size	M4

**Series** : External regenerative resistor  
**Type** : DB7.5V-21B  
**Applicable amplifier** : RYS (medium capacity):4.0kW

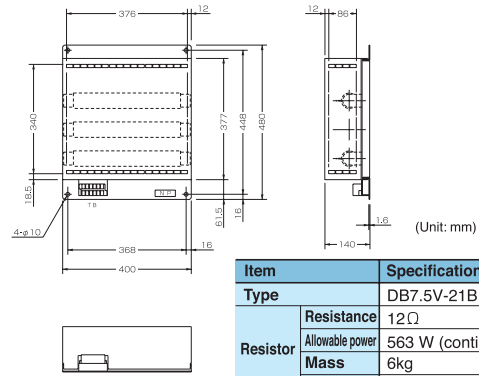

Item	Specifications	
Type	DB7.5V-21B	
Resistor	Resistance	12Ω
	Allowable power	563 W (continuous)
	Mass	6kg
	Screw size	M4

**Series** : External regenerative resistor  
**Type** : DB11V-21B  
**Applicable amplifier** : RYS (medium capacity):5.5kW

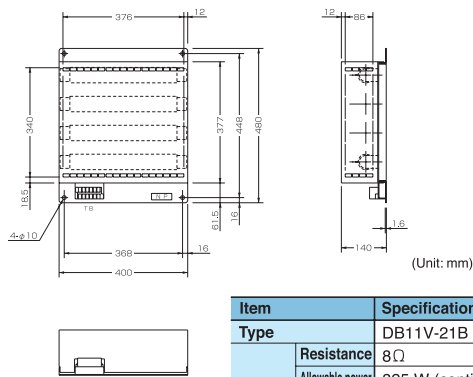

Item	Specifications	
Type	DB11V-21B	
Resistor	Resistance	8Ω
	Allowable power	825 W (continuous)
	Mass	7kg
	Screw size	M4

**Series** : External regenerative resistor  
**Type** : DB15V-21B  
**Applicable amplifier** : RYS (medium capacity):7.5kW

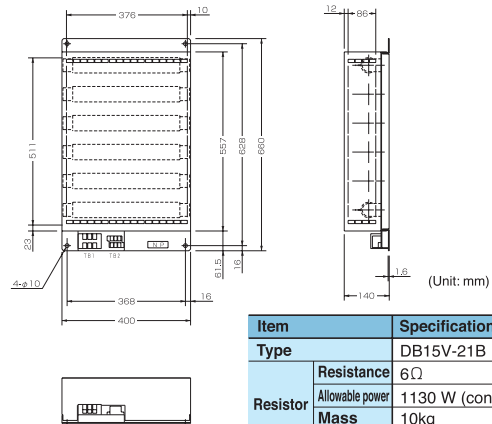

Item	Specifications	
Type	DB15V-21B	
Resistor	Resistance	6Ω
	Allowable power	1130 W (continuous)
	Mass	10kg
	Screw size	M4,M5

**Series** : External regenerative resistor  
**Type** : DB18.5V-21B  
**Applicable amplifier** : RYS (medium capacity):11kW

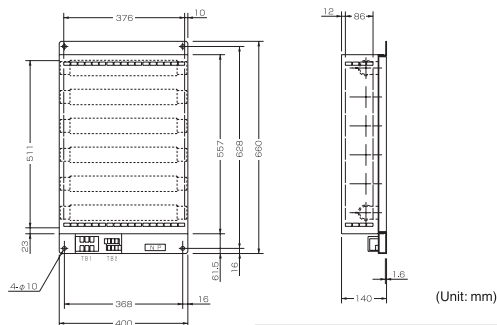

Item	Specifications	
Type	DB18.5V-21B	
Resistor	Resistance	4.5Ω
	Allowable power	1390W (continuous)
	Mass	10kg
	Screw size	M4,M5

**Series** : External regenerative resistor  
**Type** : DB22V-21B  
**Applicable amplifier** : RYS (medium capacity):15kW

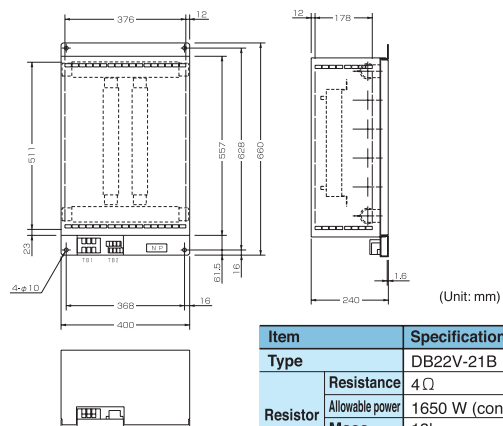

Item	Specifications	
Type	DB22V-21B	
Resistor	Resistance	4Ω
	Allowable power	1650 W (continuous)
	Mass	13kg
	Screw size	M4,M5

Model List

Servo amplifier

Pulse train/speed control type

Specifications				Product code	Type	Delivery
V VX type	DI/DO	3-phase 200V	0.05kW	RYS1051	RYS500S3-VVX	○
			0.1kW	RYS1052	RYS101S3-VVX	○
			0.2kW	RYS1053	RYS201S3-VVX	○
			0.4kW	RYS1054	RYS401S3-VVX	○
			0.75kW	RYS1055	RYS751S3-VVX	○
			1.0kW	RYS1056	RYS102S3-VVX	○
			1.5kW	RYS1057	RYS152S3-VVX	○
			2.0kW	RYS1058	RYS202S3-VVX	○
			3.0kW	RYS1059	RYS302S3-VVX	○
			4.0kW	RYS1060	RYS402S3-VVX	○
		5.0kW	RYS1061	RYS502S3-VVX	○	
		Single phase 100V	0.05kW	RYS3170	RYS500S3-VVX6	○
			0.1kW	RYS3171	RYS101S3-VVX6	○
			0.2kW	RYS3172	RYS201S3-VVX6	○
			0.375kW	RYS3173	RYS371S3-VVX6	○
			0.5kW	—	RYS501A3-VVX	△
			1.5kW	—	RYS152A3-VVX	△
			2.5kW	—	RYS252A3-VVX	△
5.0kW	—		RYS502A3-VVX	△		
V VS type	DI/DO	3-phase 200V	0.05kW	RYS1001	RYS500S3-VVS	○
			0.1kW	RYS1002	RYS101S3-VVS	○
			0.2kW	RYS1003	RYS201S3-VVS	○
			0.4kW	RYS1004	RYS401S3-VVS	○
			0.75kW	RYS1005	RYS751S3-VVS	○
			1.0kW	RYS1006	RYS102S3-VVS	○
			1.5kW	RYS1007	RYS152S3-VVS	○
			2.0kW	RYS1008	RYS202S3-VVS	○
			3.0kW	RYS1009	RYS302S3-VVS	○
			4.0kW	RYS1010	RYS402S3-VVS	○
		5.0kW	RYS1011	RYS502S3-VVS	○	
		Single phase 100V	0.05kW	RYS3073	RYS500S3-VVS6	○
			0.1kW	RYS3074	RYS101S3-VVS6	○
			0.2kW	RYS3075	RYS201S3-VVS6	○
			0.5kW	RYS3076	RYS501A3-VVS	△
			1.5kW	RYS3077	RYS152A3-VVS	△
			2.5kW	RYS3078	RYS252A3-VVS	△
			5.0kW	RYS3079	RYS502A3-VVS	△
15kW	RYS3080		RYS153M3-VVS	△		
V VS type	SX bus	3-phase 200V	0.05kW	RYS3013	RYS500S3-VSS	○
			0.1kW	RYS3014	RYS101S3-VSS	○
			0.2kW	RYS3015	RYS201S3-VSS	○
			0.4kW	RYS3016	RYS401S3-VSS	○
			0.75kW	RYS3017	RYS751S3-VSS	○
			1.0kW	RYS3018	RYS102S3-VSS	○
			1.5kW	RYS3019	RYS152S3-VSS	○
			2.0kW	RYS3020	RYS202S3-VSS	○
			3.0kW	RYS3021	RYS302S3-VSS	○
			4.0kW	RYS3022	RYS402S3-VSS	○
		5.0kW	RYS3023	RYS502S3-VSS	○	
		Single phase 100V	2.9kW	RYS1030	RYS292M3-VVK	○
			4.0kW	RYS1031	RYS402M3-VVK	○
			5.5kW	RYS1032	RYS552M3-VVK	○
			7.5kW	RYS1033	RYS752M3-VVK	○
			11kW	RYS1034	RYS113M3-VVK	○
			15kW	RYS1035	RYS153M3-VVK	○
			2.9kW	RYS3110	RYS292M3-VSK	○
4.0kW	RYS3111		RYS402M3-VSK	○		
Medium capacity	VVK type	DI/DO	5.5kW	RYS3112	RYS552M3-VSK	○
			7.5kW	RYS3113	RYS752M3-VSK	○
			11kW	RYS3114	RYS113M3-VSK	○
	VSK type	SX bus	15kW	RYS3115	RYS153M3-VSK	○

Built-in linear positioning function type

Specifications				Product code	Type	Delivery
LPS type	DI/DO	3-phase 200V	0.05kW	RYS3025	RYS500S3-LPS	○
			0.1kW	RYS3026	RYS101S3-LPS	○
			0.2kW	RYS3027	RYS201S3-LPS	○
			0.4kW	RYS3028	RYS401S3-LPS	○
			0.75kW	RYS3029	RYS751S3-LPS	○
			1.0kW	RYS3030	RYS102S3-LPS	○
			1.5kW	RYS3031	RYS152S3-LPS	○
			2.0kW	RYS3032	RYS202S3-LPS	○
			3.0kW	RYS3033	RYS302S3-LPS	○
			4.0kW	RYS3034	RYS402S3-LPS	○
		5.0kW	RYS3035	RYS502S3-LPS	○	
		Single phase 100V	0.05kW	RYS3037	RYS500S3-LSS	○
			0.1kW	RYS3038	RYS101S3-LSS	○
			0.2kW	RYS3039	RYS201S3-LSS	○
			0.4kW	RYS3040	RYS401S3-LSS	○
			0.75kW	RYS3041	RYS751S3-LSS	○
			1.0kW	RYS3042	RYS102S3-LSS	○
			1.5kW	RYS3043	RYS152S3-LSS	○
2.0kW	RYS3044		RYS202S3-LSS	○		
LSS type	SX bus	3-phase 200V	3.0kW	RYS3045	RYS302S3-LSS	○
			4.0kW	RYS3046	RYS402S3-LSS	○
			5.0kW	RYS3047	RYS502S3-LSS	○

Built-in linear positioning function type

Specifications				Product code	Type	Delivery		
LTStype	T-link	3-phase 200V	0.05kW	—	RYS500S3-LTS	△		
			0.1kW	—	RYS101S3-LTS	△		
			0.2kW	—	RYS201S3-LTS	△		
			0.4kW	—	RYS401S3-LTS	△		
			0.75kW	—	RYS751S3-LTS	△		
			1.0kW	—	RYS102S3-LTS	△		
			1.5kW	—	RYS152S3-LTS	△		
			2.0kW	—	RYS202S3-LTS	△		
			3.0kW	—	RYS302S3-LTS	△		
			4.0kW	—	RYS402S3-LTS	△		
		5.0kW	—	RYS502S3-LTS	△			
		LRS type	RS-485	3-phase 200V	0.05kW	—	RYS500S3-LRS	△
					0.1kW	—	RYS101S3-LRS	△
					0.2kW	—	RYS201S3-LRS	△
					0.4kW	—	RYS401S3-LRS	△
					0.75kW	—	RYS751S3-LRS	△
					1.0kW	—	RYS102S3-LRS	△
					1.5kW	—	RYS152S3-LRS	△
2.0kW	—				RYS202S3-LRS	△		
3.0kW	—				RYS302S3-LRS	△		
4.0kW	—				RYS402S3-LRS	△		
Medium capacity	LPK type	DI/DO	3-phase 200V	2.9kW	RYS3130	RYS292M3-LPK	△	
				4.0kW	RYS3131	RYS402M3-LPK	△	
				5.5kW	RYS3132	RYS552M3-LPK	△	
				7.5kW	RYS3133	RYS752M3-LPK	△	
				11kW	RYS3134	RYS113M3-LPK	△	
				15kW	RYS3135	RYS153M3-LPK	△	
	LSK type	SX bus	3-phase 200V	2.9kW	RYS3150	RYS292M3-LSK	△	
				4.0kW	RYS3151	RYS402M3-LSK	△	
				5.5kW	RYS3152	RYS552M3-LSK	△	
				7.5kW	RYS3153	RYS752M3-LSK	△	
				11kW	RYS3154	RYS113M3-LSK	△	
				15kW	RYS3155	RYS153M3-LSK	△	

Built-in rotation indexing function type

Specifications				Product code	Type	Delivery		
RPS type	DI/DO	3-phase 200V	0.05kW	RYS3049	RYS500S3-RPS	○		
			0.1kW	RYS3050	RYS101S3-RPS	○		
			0.2kW	RYS3051	RYS201S3-RPS	○		
			0.4kW	RYS3052	RYS401S3-RPS	○		
			0.75kW	RYS3053	RYS751S3-RPS	○		
			1.0kW	RYS3054	RYS102S3-RPS	○		
			1.5kW	RYS3055	RYS152S3-RPS	○		
			2.0kW	RYS3056	RYS202S3-RPS	○		
			3.0kW	RYS3057	RYS302S3-RPS	○		
			4.0kW	RYS3058	RYS402S3-RPS	○		
		5.0kW	RYS3059	RYS502S3-RPS	○			
		RSS type	SX bus	3-phase 200V	0.05kW	RYS3061	RYS500S3-RSS	○
					0.1kW	RYS3062	RYS101S3-RSS	○
					0.2kW	RYS3063	RYS201S3-RSS	○
					0.4kW	RYS3064	RYS401S3-RSS	○
					0.75kW	RYS3065	RYS751S3-RSS	○
					1.0kW	RYS3066	RYS102S3-RSS	○
					1.5kW	RYS3067	RYS152S3-RSS	○
2.0kW	RYS3068				RYS202S3-RSS	○		
RTS type	T-link	3-phase 200V	3.0kW	RYS3069	RYS302S3-RSS	○		
			4.0kW	RYS3070	RYS402S3-RSS	○		
			5.0kW	RYS3071	RYS502S3-RSS	○		
			0.05kW	—	RYS500S3-RTS	△		
			0.1kW	—	RYS101S3-RTS	△		
			0.2kW	—	RYS201S3-RTS	△		
			0.4kW	—	RYS401S3-RTS	△		
			0.75kW	—	RYS751S3-RTS	△		
			1.0kW	—	RYS102S3-RTS	△		
			1.5kW	—	RYS152S3-RTS	△		

○:In stock  
 ○:Semi-standard  
 △:Built to order

Servo motor

GYS motor

Specifications				Product code	Type	Delivery
Without a brake	ABS/INC	100V/200V	Without a key	GYS1001	GYS500DC1-S8B	⊙
			With a key	—	GYS500DC1-S8A	△
		200V	Without a key	GYS1002	GYS101DC1-SB	⊙
			With a key	—	GYS101DC1-SA	△
			0.2kW	GYS1003	GYS201DC1-SA	⊙
			0.4kW	GYS1004	GYS401DC1-SA	⊙
			0.75kW	GYS1005	GYS751DC1-SA	⊙
	1.0kW	GYS1006	GYS102DC1-SA	⊙		
	1.5kW	GYS1007	GYS152DC1-SA	⊙		
	2.0kW	GYS1008	GYS202DC1-SA	⊙		
	3.0kW	GYS1009	GYS302DC1-SA	⊙		
	4.0kW	GYS1010	GYS402DC1-SA	⊙		
	5.0kW	GYS1011	GYS502DC1-SA	⊙		
	100V	Without a key	GYS1042	GYS101DC1-S6B	⊙	
With a key		—	GYS101DC1-S6A	△		
0.2kW		GYS1043	GYS201DC1-S6B	⊙		
With a key		—	GYS201DC1-S6A	△		
0.375kW		GYS1044	GYS371DC1-S6B	⊙		
With a key		—	GYS371DC1-S6A	△		
0.75kW		—	GYS371DC1-S6A	△		
With a brake	ABS/INC	100V/200V	Without a key	GYS1061	GYS500DC1-C8B	⊙
			With a key	—	GYS500DC1-C8A	△
		200V	Without a key	GYS1062	GYS101DC1-CB	⊙
			With a key	—	GYS101DC1-CA	△
			0.2kW	GYS1063	GYS201DC1-CA	⊙
			0.4kW	GYS1064	GYS401DC1-CA	⊙
			0.75kW	GYS1065	GYS751DC1-CA	⊙
	100V	Without a key	GYS1102	GYS101DC1-C6B	⊙	
		With a key	—	GYS101DC1-C6A	△	
		0.2kW	GYS1103	GYS201DC1-C6B	⊙	
		With a key	—	GYS201DC1-C6A	△	
		0.375kW	GYS1104	GYS371DC1-C6B	⊙	
		With a key	—	GYS371DC1-C6A	△	
		0.75kW	—	GYS371DC1-C6A	△	
With a brake	ABS/INC	100V/200V	Without a key	GYS1021	GYS500DC1-S8B-B	⊙
			With a key	—	GYS500DC1-S8A-B	△
		200V	Without a key	GYS1022	GYS101DC1-SB-B	⊙
			With a key	—	GYS101DC1-SA-B	△
			0.2kW	GYS1023	GYS201DC1-SA-B	⊙
			0.4kW	GYS1024	GYS401DC1-SA-B	⊙
			0.75kW	GYS1025	GYS751DC1-SA-B	⊙
	1.0kW	GYS1026	GYS102DC1-SA-B	⊙		
	1.5kW	GYS1027	GYS152DC1-SA-B	⊙		
	2.0kW	GYS1028	GYS202DC1-SA-B	⊙		
	3.0kW	GYS1029	GYS302DC1-SA-B	⊙		
	4.0kW	GYS1030	GYS402DC1-SA-B	⊙		
	5.0kW	GYS1031	GYS502DC1-SA-B	⊙		
	100V	Without a key	GYS1052	GYS101DC1-S6B-B	⊙	
With a key		—	GYS101DC1-S6A-B	△		
0.2kW		GYS1053	GYS201DC1-S6B-B	⊙		
With a key		—	GYS201DC1-S6A-B	△		
0.375kW		GYS1054	GYS371DC1-S6B-B	⊙		
With a key		—	GYS371DC1-S6A-B	△		
0.75kW		—	GYS371DC1-S6A-B	△		
With a brake	ABS/INC	100V/200V	Without a key	GYS1081	GYS500DC1-C8B-B	⊙
			With a key	—	GYS500DC1-C8A-B	△
		200V	Without a key	GYS1082	GYS101DC1-CB-B	⊙
			With a key	—	GYS101DC1-CA-B	△
			0.2kW	GYS1083	GYS201DC1-CA-B	⊙
			0.4kW	GYS1084	GYS401DC1-CA-B	⊙
			0.75kW	GYS1085	GYS751DC1-CA-B	⊙
	100V	Without a key	GYS1112	GYS101DC1-C6B-B	⊙	
		With a key	—	GYS101DC1-C6A-B	△	
		0.2kW	GYS1113	GYS201DC1-C6B-B	⊙	
		With a key	—	GYS201DC1-C6A-B	△	
		0.375kW	GYS1114	GYS371DC1-C6B-B	⊙	
		With a key	—	GYS371DC1-C6A-B	△	
		0.75kW	—	GYS371DC1-C6A-B	△	

GYC motor

Specifications				Product code	Type	Delivery	
Without a brake	ABS/INC	100V/200V	0.1kW	GYC1000	GYC101DC1-SA	⊙	
			0.2kW	GYC1001	GYC201DC1-SA	⊙	
		0.4kW	GYC1002	GYC401DC1-SA	⊙		
		0.75kW	GYC1003	GYC751DC1-SA	⊙		
		1.0kW	GYC1004	GYC102DC1-SA	⊙		
		1.5kW	GYC1005	GYC152DC1-SA	⊙		
		2.0kW	GYC1006	GYC202DC1-SA	⊙		
	INC only	200V	0.1kW	GYC1040	GYC101DC1-CA	⊙	
			0.2kW	GYC1041	GYC201DC1-CA	⊙	
		0.4kW	GYC1042	GYC401DC1-CA	⊙		
		0.75kW	GYC1043	GYC751DC1-CA	⊙		
		With a brake	ABS/INC	0.1kW	GYC1020	GYC101DC1-SA-B	⊙
				0.2kW	GYC1021	GYC201DC1-SA-B	⊙
			0.4kW	GYC1022	GYC401DC1-SA-B	⊙	
0.75kW	GYC1023		GYC751DC1-SA-B	⊙			
1.0kW	GYC1024		GYC102DC1-SA-B	⊙			
INC only	200V	1.5kW	GYC1025	GYC152DC1-SA-B	⊙		
		2.0kW	GYC1026	GYC202DC1-SA-B	⊙		
	0.1kW	GYC1050	GYC101DC1-CA-B	⊙			
	0.2kW	GYC1051	GYC201DC1-CA-B	⊙			
	0.4kW	GYC1052	GYC401DC1-CA-B	⊙			
	0.75kW	GYC1053	GYC751DC1-CA-B	⊙			

GYA motor

Specifications				Product code	Type	Delivery
Without a brake	ABS/INC	200V	0.5kW	GYA1005	GYA501BC1-SA	△
			1.5kW	GYA1006	GYA152BC1-SA	△
			2.5kW	GYA1007	GYA252BC1-SA	△









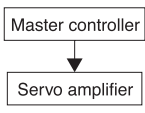

GYM motor

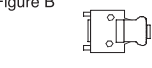
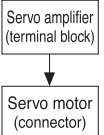
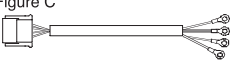
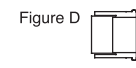
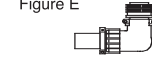
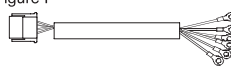
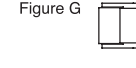
Specifications				Product code	Type	Delivery
Without a brake	INC (coupling)	200V	2.9kW	GYM1000	GYM292BC1-KC	△
			4.0kW	GYM1001	GYM402BC1-KC	△
			5.5kW	GYM1002	GYM552BC1-KC	△
			7.5kW	GYM1003	GYM752BC1-KC	△
			11kW	GYM1004	GYM113BC1-KC	△
			15kW	GYM1005	GYM153BC1-KC	△

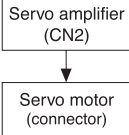
⊙ : In stock  
 ○ : Semi-standard  
 △ : Built to order





Model List

Optional cables and connectors

Name		External view		Specifications		Product code	Type	Delivery
(1)Sequence I/O wiring  	Cable (for CN1) (for CN1) (for CN3)	Figure A 	DI/DO standard 36-pin	3m (loose wire on an end)	RYWS802	WSC-D36P03	⊙	
			26-pin for SX/T-link/RS-485		RYWS801	WSC-D26P03	⊙	
			DI/DO extended 20-pin		RYWS800	WSC-D20P03	⊙	
	Connector (for CN1) (for CN1) (for CN3)	Figure B 	DI/DO standard 36-pin	RYWS022	WSK-D36P	⊙		
			26-pin for SX/T-link/RS-485	RYWS021	WSK-D26P	⊙		
			DI/DO extended 20-pin	RYWS020	WSK-D20P	⊙		
(2)Servo motor power  	Motor without a brake	Cable	Figure C 	GYS motor: 0.75kW or less	5m (loose wire on an end)	RYWS809	WSC-M04P05	⊙
				GYC motor: 0.75kW or less	10m (loose wire on an end)	RYWS810	WSC-M04P10	⊙
					20m (loose wire on an end)	RYWS811	WSC-M04P20	⊙
		Connector	Figure D   Figure E 	GYS motor: 0.75kW or less	(Figure D)	RYWS026	WSK-M04P	⊙
				GYC motor: 0.75kW or less				
				GYS motor: 1.0 to 2.0kW	(Figure E)	RYWS027	WSK-M04P-CA	⊙
	Motor with a brake	Cable	Figure F 	GYS motor: 0.75kW or less	5m (loose wire on an end)	RYWS815	WSC-M06P05	⊙
				GYC motor: 0.75kW or less	10m (loose wire on an end)	RYWS816	WSC-M06P10	⊙
					20m (loose wire on an end)	RYWS817	WSC-M06P20	⊙
		Connector	Figure G   Figure H 	GYS motor: 0.75kW or less	(Figure G)	RYWS028	WSK-M06P	⊙
				GYC motor: 0.75kW or less				
				GYS motor: 1.0 to 2.0kW	(Figure H)	RYWS029	WSK-M06P-CA	⊙
(3)Servo motor encoder wiring  	Cable	Figure I 	GYS motor: 0.75kW or less	5m (connectors on both ends)	RYWS803	WSC-P06P05	⊙	
			GYC motor: 0.75kW or less	10m (connectors on both ends)	RYWS804	WSC-P06P10	⊙	
				20m (connectors on both ends)	RYWS805	WSC-P06P20	⊙	
		Figure J 	GYS motor: 1.0kW or more	5m (connectors on both ends)	RYWS806	WSC-P06P05-C	⊙	
			GYC motor: 1.0kW or more	10m (connectors on both ends)	RYWS807	WSC-P06P10-C	⊙	
			GYA motor: 0.5 to 2.5kW (for all models) GYA motor: 2.9 to 15kW (for all models)	20m (connectors on both ends)	RYWS808	WSC-P06P20-C	⊙	
	Connector	Figure K 	Common to all models in FALDIC - $\alpha$ series	5m (loose wires on motor side)	RYWS821	WSC-P06P05-W	⊙	
				10m (loose wires on motor side)	RYWS822	WSC-P06P10-W	⊙	
				20m (loose wires on motor side)	RYWS823	WSC-P06P20-W	⊙	
		Figure L  Figure M   Figure N 	Amplifier side	(Figure L)	RYWS023	WSK-P06P-M	⊙	
			GYS motor: 0.75kW or less	(Figure M)	RYWS024	WSK-P06P-F	⊙	
			GYC motor: 0.75kW or less					
GYS motor: 1.0kW or more	(Figure N)	RYWS025	WSK-P06P-C	⊙				
GYC motor: 1.0kW or more								
GYA motor: 0.5 to 2.5kW (for all models)								
GYA motor: 2.9 to 15kW (for all models)								

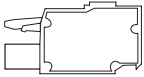
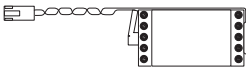
⊙ : In stock  
 ○ : Semi-standard  
 △ : Built to order

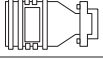
Optional cables and connectors

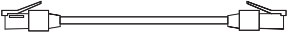
Name	External view	Description	Application	Product code	Type	Delivery	
Control power input connector kit		Used to supply control power separately to the servo amplifier.	For servo amplifier (LC1, LC2)	RYWS030	WSK-L02P	◎	
Battery (with connector)		Backup battery for ABS function	—	RYWS003	WSB-S	◎	
External regenerative resistor		Used when regenerative energy is high. For FALDIC- $\alpha$ (3000r/min, 1500r/min)	3000r/min type: 0.05 to 0.4kW	RYWS010	WSR-401	◎	
			3000r/min types: 0.75kW 1500r/min type: 0.5kW	RYWS011	WSR-751	◎	
			1.0 to 1.5kW	RYWS012	WSR-152	◎	
			2.0 to 3.0kW	RGWG339	DB11-2	◎	
			4.0 to 5.0kW	RGWG342	DB22-2	◎	
		Used when regenerative energy is high. For medium capacity type $\alpha$	2.9kW	RHWJ30C	DB5.5V-21B	◎	
			4.0kW	RHWJ30D	DB7.5V-21B	◎	
			5.5kW	RHWJ30E	DB11V-21B	◎	
			7.5kW	RHWJ30F	DB15V-21B	◎	
			11kW	RHWJ30G	DB18.5V-21B	◎	
15kW	RHWJ30H	DB22V-21B	◎				
PC Loader	Converter		RS-232C to RS-485 converter	—	NW0H003	NW0H-CNV	◎
	Cable		Interconnecting cable between the servo amplifier and converter	—	NP4H013	NP4H-CB2	◎
SX bus expansion cable		Cable for high-speed serial communication with our PLC "SPH series"	—	NP1C001	NP1C-P3	◎	





\* You can download the PC Loader software from our web site.  
<http://www.fujielectric.co.jp/fcs/>

◎ : In stock  
 ○ : Semi-standard  
 △ : Built to order

Recommended parts of motor power wiring connector for medium capacity FALDIC- $\alpha$  (GYM motor of 5.5kW or higher)





Recommended parts of the motor without a brake power wiring connector

Made by DDK

Motor type	Receptacle mounted on motor (reference)		Parts supplied by customer					
	Outside	Type	L-shape plug		Straight plug		Cable clamp	
			Outside	Type	Outside	Type	Outside	Type
GYM552BC1-KC		MS3102A32-17P		MS3108B32-17S		MS3106B32-17S		MS3057-20A
GYM752BC1-KC								
GYM113BC1-KC								
GYM153BC1-KC								

Recommended parts of the motor with a brake power wiring connector

Made by DDK

Motor type	Receptacle mounted on motor (reference)		Parts supplied by customer					
	Outside	Type	L-shape plug		Straight plug		Cable clamp	
			Outside	Type	Outside	Type	Outside	Type
GYM552BC1-KC-B		MS3102A32-17P ☆ MS3102A10SL-3P		MS3108B32-17S ☆ CE05-8A10SL-3SC-B-BAS		MS3106B32-17S ☆ MS3106A10SL-3S		MS3057-20A ☆ MS3057-4A
GYM752BC1-KC-B								
GYM113BC1-KC-B								
GYM153BC1-KC-B								

Note: In the Type column with 2-line data, upper line indicates the motor main circuit, and lower line with ☆ indicates the connector for brake power.

## Service Network



## Fuji FA Service Centers

- Overseas Service Center  
[Service Area: Far East Asia]  
5-7, Nihonbashi  
Odemma-cho, Chuo-ku, Tokyo, 103-0011, Japan  
Phone: (03)5847-8072
- USA Service Center  
[Service Area: USA, Canada, Central & South America]  
5550 Cerritos Ave. Suite H Cypress, CA. 90630  
USA  
Phone: (714)220-1879
- CHICAGO Service Station  
4825 N. Scott St. Suite 210, Schiller Park, IL 60176  
USA  
Phone: (847)233-9844
- EC Service Center  
[Service Area: Europe, Middle East & Africa]  
Goethering 58, 63067  
Offenbach/ Main Germany  
Phone: (69)669029-0
- South East Asia & Oceania Service Center  
[Service Area: SE & S Asia, Oceania]  
171 Chin Swee Road, #12-01,  
San Centre, Singapore 169877  
Phone: (6481)5079
- FUJI-ELECTRIC TECHNOLOGY AND  
SERVICE (SHENZHEN) CO., LTD  
[Service Area: China]  
5F, Liming Bldg., No.144,  
Zhongxing Rd., Luohu District, Shenzhen  
Phone: (0755)8220-2745, 8218-4287

## Contracted Service Companies

- USA, Canada, Central & South America Area  
USA  
OESS CORPORATION(Head Office:NEW  
JERSEY)
- ① NEW JERSEY  
800 Huyler Street Teterboro, NJ 07608, USA  
Phone: (201)288-4422
- ② CHICAGO  
4825 N Scott Suite 210, Schiller park, IL 60176,  
USA  
Phone: (847)233-9412
- ③ LOS ANGELES  
5550 Cerritos Ave. Suite H, Cypress, CA 90630  
USA  
Phone: (714)220-1879
- ④ SAN JOSE  
1440, Koll Circle, Suite 107, San Jose, CA 95112  
USA  
Phone: (408)437-1582
- ⑤ PORTLAND  
7921 SW Cirrus Drive, Beaverton, OR 97008, USA  
Phone: (503)520-5044
- Far East Asia Area
- ⑥ KOREA  
GAIUS INDUSTRIES CO., LTD.  
Cana Bldg., 10-59, Yangjae-Dong, Seocho-Gu,  
Seoul, 137-887, R.O. KOREA  
Phone: (02)3463-0766

- ⑦ TAIWAN  
ELTA Electrical Co., Ltd.  
4F, No.32. Sec. 3, Cheng TehRoad,  
Taipei, Taiwan  
Phone: (02)2597-6458
- ⑦ TAIWAN  
Full Key International Technology Ltd  
12F, No.111-8, HSING TEH RD., SAN-CHUNG  
CITY, TAIPEI, TAIWAN  
Phone: (02)2995-2008
- Europe, Middle East & Africa Area
- ⑧ F.R.GERMANY  
OESS GmbH.  
Senefelder Strasse 1, 63110 Rodgau,  
F.R.GERMANY  
Phone: (06106)285-7890
- SE & S Asia, Oceania
- ⑨ SINGAPORE  
Fuji Technical Center (S'pore) Pte Ltd.  
Block 5000 Ang Mo kio Ave 5 #02-03 Techplacell  
SINGAPORE 569870  
Phone: (6481)5079
- ⑩ AUSTRALIA  
CNC and ROBOTIC AUTOMATED SERVICES  
Unit 33/16 Macquarie Place Boronia Victoria 3155,  
AUSTRALIA  
Phone: (03)9483-8629
- ⑪ INDIA  
AUTONUM CONTROLS PVT LTD.  
109, Sagar Building, Prabhat Industrial Estate,  
W.E. Highway, Befor Check Naka, Dahisar-East,  
Mumbai 400 068 INDIA  
Phone: (022)28960027

The warranty of this product is as follows unless the special instructions state otherwise in the quote, contract, catalogue, or specifications at the time of quote or order.

The purpose or area of use may be limited, and a routine checkup may be required depending on the product. Please contact the distributor from which you purchased the product from, or Fuji Electric for further information.

Please conduct prompt incoming inspection of the product upon purchase or delivery. Also, please give enough consideration to management and maintenance of the product prior to accepting the product.

### 1. Period and coverage of the warranty

#### 1-1 Period

- (1) The period of the warranty is effective until the earliest of either a year from the date of purchase or, eighteen (24) months from the date of manufacture printed on the plate.
- (2) The above period may not be applicable in case the particular environment, conditions or frequency of use affects the lifetime of the product.
- (3) The warranty for the parts repaired by Fuji Electric service department is effective for six months from the date of repair.

#### 1-2 Coverage

- (1) If malfunction occurs in the period of warranty due to Fuji Electric, the malfunctioning parts are exchanged or repaired for free at the point of purchase or delivery. However, the warranty does not apply to the following cases.
  - 1) The malfunction occurs due to inappropriate conditions, environment, handling or usage that is not instructed in a catalogue, instruction book or user's manual.
  - 2) The malfunction is caused by the factors that do not originate in the purchased or delivered product.
  - 3) The malfunction is caused by other devices or software design that does not originate in Fuji Electric products.
  - 4) The malfunction occurs due to an alteration or repair that is not performed by Fuji Electric.
  - 5) The malfunction occurs because the expendable parts listed in an instruction book or catalogue were not maintained nor exchanged in an appropriate manner.
  - 6) The malfunction occurs due to factors that were not foreseeable by the practical application of science and technology at the time of purchase or delivery.
  - 7) The malfunction occurs because the product is used for an unintended purpose.
  - 8) The malfunction occurs due to a disaster or natural disaster that Fuji Electric is not responsible for.
- (2) The warranty is only applicable to the single purchased delivered product.
- (3) The warranty covers only the area stated in above (1). Any damage induced by the malfunction of the purchased or delivered product, including the damage or loss to a device or machine and passive damages, is not covered by the warranty.

#### 1-3 Malfunction diagnosis

Malfunction is to be diagnosed temporarily by the purchaser. This diagnosis can be conducted by Fuji Electric or its delegated service provider with due charge upon the request from the purchaser. The charge is to be paid by the purchaser at the rate stipulated in the rate schedule of Fuji Electric.

### 2. Liability for opportunity loss

Regardless of the time period of the occurrence, Fuji Electric is not liable for the damage caused by the factors Fuji Electric is not responsible for, opportunity loss of the purchaser caused by malfunction of Fuji Electric product, passive damages, damage caused due to special situations regardless of whether it was foreseeable or not, and secondary damage, accident compensation, damage to products that were not manufactured by Fuji Electric, and compensation towards other operations.

### 3. Period for repair and provision of spare parts after the production is discontinued (maintenance period)

The discontinued models (products) can be repaired for seven years from the date of discontinuation. Also, most spare parts used for repair are provided for seven years from the date of discontinuation. However, some electric parts may not be obtained due to their short life cycle. In this case, repair or provision of the parts may be difficult in the above period. Please contact Fuji Electric or its service providers for further information.

### 4. Delivered term

Standard products that do not entail application setting or adjustment are regarded as received by the purchaser upon delivery. Fuji Electric is not responsible for local adjustments and test runs.

### 5. Service

The price of the delivered or purchased products does not include the service fee for the technician. Please contact Fuji Electric or its service providers for further information.

### 6. Scope of application

Above contents shall be assumed to apply to transactions and use of the country where you purchased the products. Consult the local supplier or Fuji for the detail separately.

## Reference Material

**Motion controller  
MICREX-SX Series SPH**

Various CPUs matching your purposes are included in the line of products.

- Module type (Up to 64 axes control)
- PCI bus compatible board type (Up to 32 axes control)
- Selection of program language best for the control (LD, ST or FB language)



Catalog (LEH982)

**Programmable operation display  
UG Series POD**

Various products ranging from 5.7" (QVGA) to 15" (XGA) types are included in the product line.

Full color (32,768 colors) realizes colorful and beautiful screen expression.



Catalog (LEH854)

## SAFETY PRECAUTIONS

- 1 This catalog is intended for use in selecting required servo systems. Before actually using these products, carefully read their instruction manuals and understand their correct usage.
2. Products described in this catalog are neither designed nor manufactured for combined use with a system or equipment that will affect human lives.  
If you are considering using these products for special purposes, such as atomic energy control, aerospace, medical application, or traffic control, please consult our sales office.
3. If you use our product with equipment that is expected to cause serious injury or damage to your property in case of failure, be sure to take appropriate safety measures for the equipment.

The Inverter Value Engineering Center (Suzuka Area) has acquired environment management system ISO14001 and quality management system ISO9001 certifications.



---

## Fuji Electric Systems Co., Ltd.

Gate City Ohsaki, East Tower, 11-2, Osaki 1-chome  
Shinagawa-ku, Tokyo 141-0032, Japan  
Phone: +81-3-5435-7283 Fax: +81-3-5435-7425

Printed on recycled paper

Information in this catalog is subject to change without notice.

Printed in Japan 2008-4 (D08d/F07a) 00CM