

Product datasheet

Specifications



motion servo drive - Lexium 26 - single and three phase 200...230 V - 1 kW

LXM26DU10M3X

Main

Range of product	Easy Lexium 26
Device short name	LXM26D
Product or component type	Motion servo drive
Format of the drive	Compact housing
Line current	8.5 A 176.3 % at 220 V, single phase 8.5 A 155.5 % at 220 V, three phase

Complementary

Network number of phases	Single phase Three phase
[Us] rated supply voltage	220 V (- 10...15 %) for three phase 220 V (- 20...15 %) for single phase
Supply voltage limits	200...255 V three phase 170...255 V single phase
Supply frequency	50/60 Hz - 5...5 %
Network frequency	47.5...63 Hz
Continuous output current	7 A at 16 kHz
Output current 3s peak	21 A at 220 V
Continuous power	1000 W at 220 V
Nominal power	1 kW at 220 V 16 kHz
Switching frequency	16 kHz
Overvoltage category	III
Maximum leakage current	4.5 mA
Output voltage	<= power supply voltage
Electrical isolation	Between power and control
Type of cable	Twisted shielded pairs cable (single or double) (temperature: 0...55 °C)
Electrical connection	Spring terminal, clamping capacity: 1.3...1.5 mm ² , AWG 16 (L1-L2) Spring terminal, clamping capacity: 1.3...1.5 mm ² , AWG 16 (R, S, T) Spring terminal, clamping capacity: 1.3...1.5 mm ² , AWG 16 (U, V, W, PE) Spring terminal, clamping capacity: 1.3...1.5 mm ² , AWG 16 (PA+, PBe)
Tightening torque	PE (ground): 1.4 N.m
Discrete input number	8 programmable (CN1) 1 pulse train input (PTI) (CN1) 2 fast capture (CN1)
Discrete input voltage	24 V DC for logic
Discrete input logic	Positive or negative (CN1)

Discrete output number	1 5
Discrete output type	Logic (CN1) at 12...24 V DC Pulse train output (PTO) (CN1)
Discrete output voltage	12...24 V DC
Discrete output logic	Positive or negative (CN1)
Analogue input number	2
Absolute accuracy error	0.1 %
Analogue input type	V_REF voltage analog input: - 10...10 V, impedance: 10 kOhm, resolution: 12 bits T_REF voltage analog input
Control signal type	Servo motor encoder feedback CN2
Protection type	Against reverse polarity: inputs signal Against short-circuits: outputs signal Overcurrent: motor Overvoltage: motor Undervoltage: motor Overheating: motor Overload: motor Overspeed: motor
Physical interface	RS485 for Modbus Serial line slave
Status LED	1 LED (red) charge
Signalling function	Servo status and fault codes five 7-segment display units
Marking	CULus CE
Type of cooling	Integrated fan
Operating position	Vertical
Product compatibility	Servo motor BCH2 (130 mm, 1 motor stacks) Servo motor BCH2 (100 mm, 1 motor stacks) Servo motor BCH2 (130 mm, 2 motor stacks) Servo motor BCH2 (130 mm, 3 motor stacks)
Width	55 mm
Height	150 mm
Depth	177 mm
Net weight	1.2 kg

Environment

EMC filter	Without EMC filter
Electromagnetic compatibility	Conducted emission - test level: level 3 category C3 conforming to IEC 61800-3
Standards	IEC 61800-5-1
Product certifications	cULus CE
IP degree of protection	IP20
Vibration resistance	3M4 amplitude = 3 mm (f = 9...200 Hz) conforming to IEC 60721-3-3
Shock resistance	10 gn, type I conforming to IEC 60068-2-27
Relative humidity	5...95 % without condensation
Ambient air temperature for operation	0...55 °C
Ambient air temperature for storage	-25...65 °C

Operating altitude	<= 1000 m without derating > 1000...2000 m 1 % per 100 m
---------------------------	---

Packing Units

Unit Type of Package 1	PCE
-------------------------------	-----

Number of Units in Package 1	1
-------------------------------------	---

Package 1 Height	7.519 cm
-------------------------	----------

Package 1 Width	22.845 cm
------------------------	-----------

Package 1 Length	23.714 cm
-------------------------	-----------

Package 1 Weight	1.471 kg
-------------------------	----------

Unit Type of Package 2	S03
-------------------------------	-----

Number of Units in Package 2	5
-------------------------------------	---

Package 2 Height	30.0 cm
-------------------------	---------

Package 2 Width	30.0 cm
------------------------	---------

Package 2 Length	40.0 cm
-------------------------	---------

Package 2 Weight	8.0 kg
-------------------------	--------

Contractual warranty

Warranty (in months)	18
-----------------------------	----



Environmental Data

Schneider Electric aims to achieve Net Zero status by 2050 through supply chain partnerships, lower impact materials, and circularity via our ongoing “Use Better, Use Longer, Use Again” campaign to extend product lifetimes and recyclability.

[Environmental Data explained >](#)

[How we assess product sustainability >](#)



Environmental footprint

Total lifecycle Carbon footprint	2 769 kg CO2 eq.
Environmental Disclosure	Product Environmental Profile
Carbon footprint of the manufacturing phase [A1 to A3]	24 kg CO2 eq.
Carbon footprint of the distribution phase [A4]	0.2 kg CO2 eq.
Carbon footprint of the installation phase [A5]	0 kg CO2 eq.
Carbon footprint of the use phase [B2, B3, B4, B6]	2 744 kg CO2 eq.
Carbon footprint of the end-of-life phase [C1 to C4]	0.7 kg CO2 eq.

Use Better



Materials and Packaging

Packaging made with recycled cardboard	No
Packaging without single use plastic	No
PVC free	Yes

Use Longer



Lifetime extension

Repair	No
--------	----

Use Again



Repack and remanufacture

Recyclability potential, in %	40
End of life manual availability	End of Life Information
Take-back	No
WEEE Label	 The product must be disposed on European Union markets following specific waste collection and never end up in rubbish bins

Dimensions Drawings

Dimensions

Servo Drive Dimensions

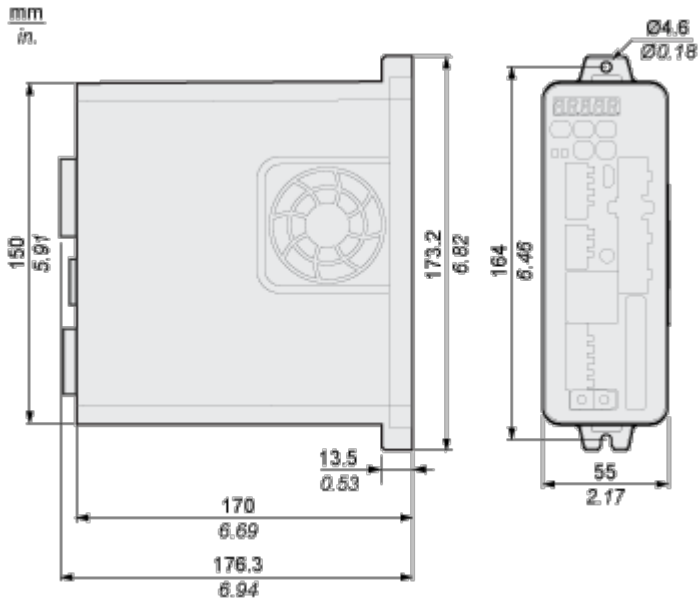

Mounting and Clearance

Mounting and Clearance

Clearance

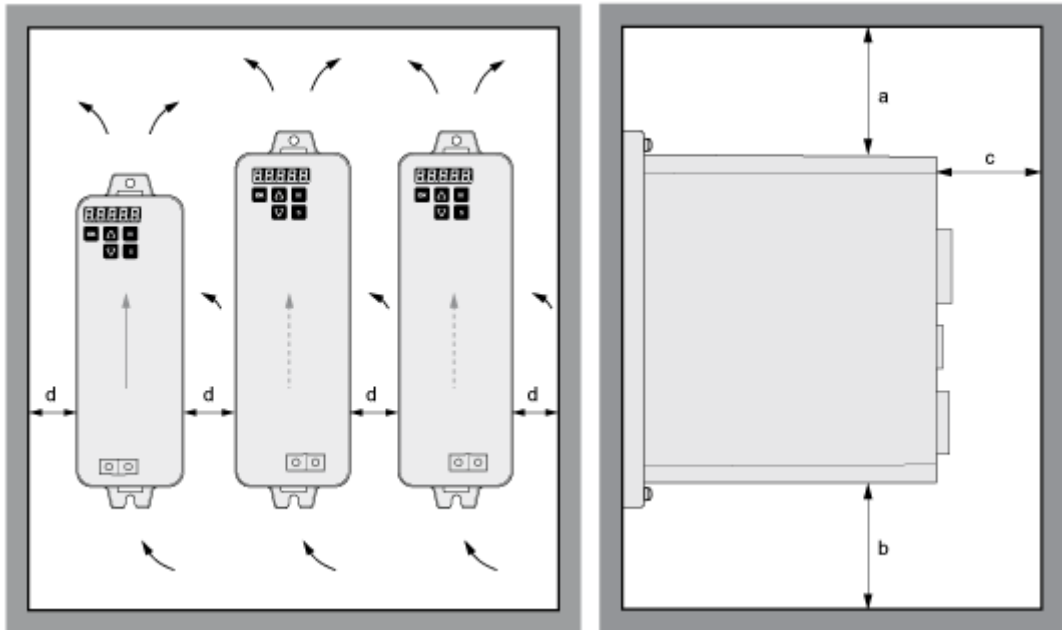

Distance	Unit	Value
Free space a above the device	mm (in)	≥ 50 ≥ 1.97
Free space b below the device	mm (in)	≥ 50 ≥ 1.97
Free space c in front of the device ⁽¹⁾	mm (in)	≥ 60 ≥ 2.36
Free space d between devices	mm (in)	≥ 15 ≥ 0.59