



## Asia

Delta Electronics (Jiangsu) Ltd.

Zhangjiagang Haina Automation Equipment Co., Ltd.

Sales office

No. 11, Yuefeng Road, Economic Development Zone,

Zhangjiagang, Jiangsu, China (Mainland)

TEL:0086-0512-56322086 008615262314665

EMAIL:samzhang@haina-auto.com

Delta Economic AC Servo Drive with DMCNET Communication ASDA-B2-F Series User Manual



# Delta Economic AC Servo Drive with DMCNET Communication ASDA-B2-F Series User Manual

\*We reserve the right to change the information in this manual without prior notice.



# Preface

---

Thank you for purchasing ASDA-B2-F. This user manual provides related information of ASDA-B2-F series servo drive and ECMA series servo motors.

This manual includes:

- Installation and inspection of the servo drive and servo motor
- Configuration of the servo drive
- Procedures of trial run
- Control functions and adjustment methods of the servo drive
- Parameter settings
- Communication protocol
- Maintenance and inspection
- Troubleshooting

## Features

B2-F is a cost-effective servo drive for application which requires multi-axis motion control and can be operated via DMCNET high-speed network. Besides high response, B2-F also supports absolute functions and multi-axis operation.

## How to use this manual

Users can refer to this user manual during installation, setting, operation and maintenance. Before tuning and setting, please read through Chapter 1 to 5. This user manual provides specific table of contents and index for searching. If the requiring information is not available in the table of contents, please refer to the index.

## Technical Supports

If you have any question, please contact local distributors or Delta's service center.

(This page is intentionally left blank.)

# Table of Contents

---

## Before Operation

### 1

#### Inspection and Model Explanation

1.1	Inspection.....	1-2
1.2	Product Model.....	1-3
1.2.1	Nameplate Information.....	1-3
1.2.2	Model Explanation.....	1-4
1.3	Servo Drive and Corresponding Servo Motor.....	1-6
1.4	Each Part of the Servo Drive.....	1-7

### 2

#### Installation

2.1	Notes.....	2-2
2.2	Ambient Conditions of Storage.....	2-2
2.3	Ambient Conditions of Installation.....	2-2
2.4	Installation Direction and Space.....	2-3
2.5	Specification of Circuit Breaker and Fuse.....	2-5
2.6	EMI Filter Selection.....	2-5
2.7	Selection of Regenerative Resistor.....	2-7

### 3

#### Wiring

3.1	Connections.....	3-2
3.1.1	Connecting to Peripheral Devices.....	3-2
3.1.2	Connectors and Terminals of Servo Drive.....	3-3
3.1.3	Wiring Method.....	3-4
3.1.4	Specification of Motor Power Cable.....	3-5
3.1.5	Specification of Encoder Cable Connector.....	3-7
3.1.6	Selection of Wiring Rod.....	3-10
3.2	Basic Wiring.....	3-11
3.2.1	200 W or models below (without built-in regenerative resistor nor fan).....	3-11
3.2.2	400 W ~ 750 W models (with built-in regenerative resistor but no fan).....	3-12
3.2.3	1 kW ~ 1.5 kW models (with built-in regenerative resistor and fan).....	3-13
3.2.4	2 kW ~ 3 kW models (with built-in regenerative resistor and fan).....	3-14
3.3	I / O Signal (CN1) Connection.....	3-15

3.3.1	I / O Signal (CN1) Connector Terminal Layout	3-15
3.3.2	Signals Explanation of Connector CN1	3-16
3.3.3	Wiring Diagrams (CN1)	3-18
3.3.4	DI and DO Signal Specified by Users	3-20
3.4	CN2 Connector	3-21
3.5	Wiring of CN3 Connector	3-23
3.6	CN6 Connector (DMCNET)	3-24
3.7	Standard Connection Example	3-26

## 4

### Panel Display and Operation

4.1	Panel Description	4-2
4.2	Parameter Setting Procedure	4-3
4.3	Status Display	4-6
4.3.1	Save Setting Display	4-6
4.3.2	Decimal Point	4-6
4.3.3	Alarm Message	4-6
4.3.4	Positive and Negative Sign Setting	4-7
4.3.5	Monitor Display	4-7
4.4	General Function	4-10
4.4.1	Operation of Fault Record Display	4-10
4.4.2	JOG Mode	4-11
4.4.3	Force DO Output	4-12
4.4.4	Digital Input Diagnosis Operation	4-13
4.4.5	Digital Output Diagnosis Operation	4-14

## Tuning

## 5

### Trial Operation and Tuning

5.1	Inspection without Load	5-2
5.2	Apply Power to the Servo Drive	5-3
5.3	JOG Trial Run without Load	5-7
5.4	Trial Run without Load (Speed Mode)	5-8
5.5	Tuning Procedure	5-10
5.5.1	Flowchart of Tuning Procedure	5-11
5.5.2	Inertia Estimation Flowchart (with Mechanism)	5-12
5.5.3	Flowchart of Auto Tuning	5-13
5.5.4	Flowchart of Semi-Auto Tuning	5-14
5.5.5	Limit of Inertia Ratio	5-15
5.5.6	Mechanical Resonance Suppression Method	5-17

5.5.7	Tuning Mode and Parameters .....	5-18
5.5.8	Tuning in Manual Mode .....	5-19

# 6

## Control Mode of Operation

6.1	Selection of Operation Mode .....	6-2
6.2	Position Mode .....	6-3
6.2.1	Control Structure of Position Mode .....	6-3
6.2.2	S-curve Filter (Position) .....	6-4
6.2.3	Electronic Gear Ratio .....	6-5
6.2.4	Low-pass Filter .....	6-6
6.2.5	Gain Adjustment of Position Loop .....	6-6
6.2.6	Low-frequency Vibration Suppression in Position Mode .....	6-7
6.3	Speed Mode .....	6-10
6.3.1	Selection of Speed Command .....	6-10
6.3.2	Control Structure of Speed Mode .....	6-11
6.3.3	Smooth Speed Command .....	6-12
6.3.4	Timing Diagram of Speed Mode .....	6-13
6.3.5	Gain Adjustment of Speed Loop .....	6-14
6.3.6	Resonance Suppression .....	6-18
6.4	Torque Mode .....	6-23
6.4.1	Selection of Torque Command .....	6-23
6.4.2	Control Structure of Torque Mode .....	6-24
6.4.3	Smooth Torque Command .....	6-25
6.4.4	Timing Diagram of Torque Mode .....	6-25
6.5	The Use of Brake .....	6-26

## Parameter Setting

# 7

## Parameters

7.1	Parameter Definition .....	7-2
7.2	List of Parameters .....	7-3
7.3	Parameter Description .....	7-10
P0-xx	Monitor Parameters .....	7-10
P1-xx	Basic Parameters .....	7-22
P2-xx	Extension Parameters .....	7-37
P3-xx	Communication Parameters .....	7-50
P4-xx	Diagnosis Parameters .....	7-55
P5-xx	Motion Setting Parameters .....	7-59

Table 7.1	Function Description of Digital Input (DI).....	7-63
Table 7.2	Function Description of Digital Output (DO).....	7-65

# 8

## Communications

8.1	RS-232 Communication Hardware Interface .....	8-2
8.2	RS-232 Communication Parameters Setting .....	8-3
8.3	MODBUS Communication Protocol.....	8-4
8.4	Setting and Accessing Communication Parameters .....	8-15

## Troubleshooting

# 9

## Troubleshooting

9.1	Alarm of Servo Drive.....	9-2
9.2	Alarm of DMCNET Communication .....	9-3
9.3	Alarm of Motion Control.....	9-4
9.4	Causes and Corrective Actions .....	9-5

# 10

## Absolute System

10.1	Absolute Type of Battery Box and Wiring Rods.....	10-3
10.1.1	Specifications .....	10-3
10.1.2	Battery Box Dimensions .....	10-5
10.1.3	Connection Cable for Absolute Encoder .....	10-6
10.1.4	Battery Box Cable.....	10-8
10.2	Installation.....	10-9
10.2.1	Install Battery Box in Servo System .....	10-9
10.2.2	How to Install the Battery.....	10-13
10.2.3	How to Replace a Battery .....	10-14
10.3	Parameters Related to Absolute Servo System.....	10-16
10.4	Servo Drive Alarm List for Absolute Function and Monitoring Variables .....	10-17
10.5	System Initialization and Operation Procedures .....	10-18
10.5.1	System Initialization.....	10-18
10.5.2	Pulse Number .....	10-19
10.5.3	PUU Number .....	10-20
10.5.4	To Initialize the Absolute Coordinate via Parameters .....	10-21
10.5.5	Use Communication to Access Absolute Position .....	10-21

# Appendix

## A

### Specifications

Specifications of ASDA-B2-F Servo Drive .....	A-2
Specifications of Servo Motors (ECMA Series) .....	A-4
Torque Features (T-N Curves) .....	A-13
Overload Features .....	A-15
Dimensions of Servo Drive .....	A-17
Dimensions of Servo Motor .....	A-21

## B

### Accessories

Power Connector .....	B-2
Power Cable .....	B-3
Encoder Connector .....	B-5
Encoder Cable .....	B-5
Encoder Cable (Absolute Type) .....	B-6
Battery Box Cable AW .....	B-7
Battery Box Cable IW .....	B-7
Battery Box (Absolute Type) .....	B-8
I/O Connector Terminal .....	B-9
CN1 Convenient Connector .....	B-9
PC Connection Cable .....	B-10
Terminal Block Module .....	B-10
Optional Accessories .....	B-11

## C

### Maintenance and Inspection

Basic Inspection .....	C-2
Maintenance .....	C-3
The Lifetime of Machinery Parts .....	C-3

(This page is intentionally left blank.)

# Inspection and Model Explanation

---

# 1

Before using ASDA-B2-F, please pay attention to the description about the inspection, nameplate, and model type. Suitable motor model for your servo drive can be found in the table of Chapter 1.3.



1.1	Inspection.....	1-2
1.2	Product Model .....	1-3
1.2.1	Nameplate Information .....	1-3
1.2.2	Model Explanation.....	1-4
1.3	Servo Drive and Corresponding Servo Motor.....	1-6
1.4	Each Part of the Servo Drive.....	1-7

1

### 1.1 Inspection

In order to prevent the negligence during purchasing and delivery, please inspect the following items carefully.

Item	Description
Please check if the product is what you have purchased.	Check the part number of the motor and the servo drive on the nameplate. Refer to the next page for the model explanation.
Check if the motor shaft can rotate smoothly.	Rotate the motor shaft by hand. If it can be rotated smoothly, it means the motor shaft is normal. However, it cannot be rotated by hand if the motor has an electromagnetic brake.
Check if there is any damage shown on its appearance.	Visually check if there is any damage or scrape of the appearance.
Check if there is any loose screw.	Make sure no screw is un-tightened or fall off.

If any of the above situations happens, please contact the distributors to solve the problems.

A complete and workable servo set should include:

- (1) One servo drive and one servo motor.
- (2) One UVW motor power cable, the U, V and W wires can connect to the socket attached by the servo drive and another side is the plug which could connect to the socket of the motor. And a green ground wire which should be connected to the ground terminal of the servo drive. (selective purchase)
- (3) An encoder cable which connects to the socket of the encoder. One side of it connects to CN2 servo drive and another side is the plug. (selective purchase)
- (4) 15-PIN connector which is used in CN1 (selective purchase)
- (5) 9-PIN connector which is used in CN2. (selective purchase)
- (6) 6-PIN connector which is used in CN3. (selective purchase)
- (7) RJ-45 connector which is used in CN6.

## 1.2 Product Model

### 1.2.1 Nameplate Information

#### ASDA-B2-F Series Servo Drive

- Nameplate Information

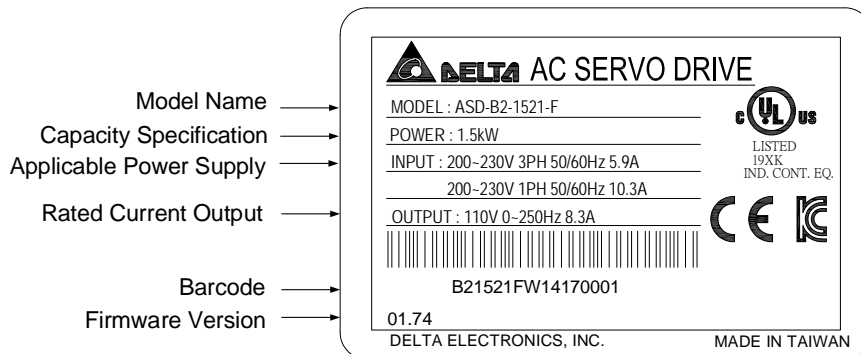

- Serial Number

B21521F W 14 17 0001  
 ①      ②      ③      ④      ⑤

- ① Model Name
- ② Production Factory (T: Taoyuan; W: Wujiang)
- ③ Year of Production (3: year 2013 or 14: year 2014)
- ④ Week of Production (from 1 to 52)
- ⑤ Serial Number  
(Production sequence of a week, starting from 0001)

#### ECMA Series Servo Motor

- Nameplate Information

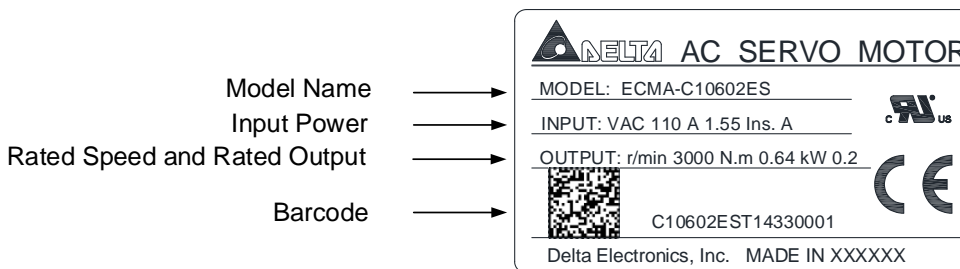

- Serial Number

C10602ES T 14 33 0001  
 ①      ②      ③      ④      ⑥

- ① Model Name
- ② Production Factory (T: Taoyuan; W: Wujiang)
- ③ Year of Production (14: year 2014)
- ④ Week of Production (from 1 to 52)
- ⑤ Serial Number  
(Production sequence of a week, starting from 0001)

1.2.2 Model Explanation

ASDA-B2-F Series Servo Drive

**A S D - B 2 - 0 4 2 1 - F**  
 ①                      ②                      ③                      ④                      ⑤

① **Product Name**

AC Servo Drive

② **Series**

B2

③ **Rate Output Power**

Code	Spec.	Code	Spec.
01	100 W	10	1 kW
02	200 W	15	1.5 kW
04	400 W	20	2 kW
07	750 W	30	3 kW

④ **Input Voltage and Phase**

Code	Voltage / Phase
21	220V 1 phase
23	220V 3 phase

⑤ **Model Type**

Type	Full-Closed Control	EtherCAT	CANopen	DMCNET	E-CAM	Extension Port for Digital Input
F	x	x	x	o	x	x

**ECMA Series Servo Motor**

E C M A - C 1 0 6 0 2 E S  
 ①            ②            ③            ④            ⑤            ⑥            ⑦

1

① **Product Name** ECM: Electronic Commutation Motor

② **Motor Type** A: AC Servo Motor

③ **Name of the Series**

Rated Voltage and Rated Speed		Encoder Type	
Code	Spec.	Code	Spec.
<u>C</u>	220 V / 3,000 rpm	1	Incremental type, 20-bit
<u>E</u>	220 V / 2,000 rpm	2	Incremental type, 17-bit
<u>F</u>	220 V / 1,500 rpm	3	2500 ppr
<u>G</u>	220 V / 1,000 rpm	M	Magnet type, 13-bit

④ **Motor Frame Size**

code	Spec.	code	Spec.
04	40 mm	10	100 mm
06	60 mm	13	130 mm
08	80 mm	18	180 mm
09	86 mm	-	-

⑤ **Rated Power Output**

code	Spec.	code	Spec.	code	Spec.
01	100 W	05	500 W	10	1.0 kW
02	200 W	06	600 W	15	1.5 kW
03	300 W	07	700 W	20	2.0 kW
04	400 W	09	900 W	30	3.0 kW

⑥ **Type of Shaft Diameter and Oil Seal**

	w/o Brake, w/o Oil Seal	with Brake, w/o Oil Seal	w/o Brake, with Oil Seal	With Brake, with Oil Seal
Round Shaft (with fixed screw holes)	-	-	C	D
Keyway	E	F	-	-
Keyway (with fixed screw holes)	P	Q	R	S

⑦ **Shaft Diameter**

Standard	S	
Specific	3	42 mm
	7	14 mm

### 1.3 Servo Drive and Corresponding Servo Motor

		Motor				Servo Drive			
Motor series	Power	Output (W)	Model Number	Rated Current (Arms)	Max. Instantaneous current (A)	Model Number	Continuous Output Current (Arms)	Max. Instantaneous output current (A)	
Low Inertia	ECMA-C 3000 r/min	Single-/Three-phase	50	ECMA-C1040F□S	0.69	2.05	ASD-B2-0121-F	0.90	2.70
			100	ECMA-CΔ0401□S	0.90	2.70			
			200	ECMA-CΔ0602□S	1.55	4.65			
			ASD-B2-0421-F	400	ECMA-CΔ0604□S	2.60	7.80		
				400	ECMA-CΔ0804□7	2.60	7.80		
			ASD-B2-0721-F	750	ECMA-CΔ0807□S	5.10	15.30		
				750	ECMA-CΔ0907□S	3.66	11.00		
			ASD-B2-1021-F	1000	ECMA-CΔ0910□S	4.25	12.37		
				1000	ECMA-CΔ1010□S	7.30	21.90		
			ASD-B2-2023-F	2000	ECMA-CΔ1020□S	12.05	36.15		
ASD-B2-3023-F	3000	ECMA-CΔ1330□4	17.2	47.5					
Medium Inertia	ECMA-E 2000 r/min	Single-/Three-phase	500	ECMA-EΔ1305□S	2.90	8.70	ASD-B2-0421-F	2.60	7.80
			1000	ECMA-EΔ1310□S	5.60	16.80	ASD-B2-1021-F	7.30	21.90
			1500	ECMA-EΔ1315□S	8.30	24.90	ASD-B2-1521-F	8.30	24.90
			2000	ECMA-EΔ1320□S	11.01	33.03	ASD-B2-2023-F	13.40	40.20
			2000	ECMA-EΔ1820□S	11.22	33.66			
			3000	ECMA-EΔ1830□S	16.10	48.30	ASD-B2-3023-F	19.40	58.20
Medium-high inertia	ECMA-F 1500 r/min	Single-/Three-phase	850	ECMA-FΔ1308□S	7.10	19.40	ASD-B2-1021-F	7.30	21.90
			1300	ECMA-FΔ1313□S	12.60	38.60	ASD-B2-2023-F	13.40	40.20
			3000	ECMA-FΔ1830□S	19.40	58.20	ASD-B2-3023-F	19.40	58.20
High Inertia	ECMA-C/G 3000 r/min	Single-/Three-phase	400	ECMA-CΔ0604□H	2.60	7.80	ASD-B2-0421-F	2.60	7.80
			750	ECMA-CΔ0807□H	5.10	15.30	ASD-B2-0721-F	5.10	15.30
			300	ECMA-GΔ1303□S	2.50	7.50	ASD-B2-0421-F	2.60	7.80
			600	ECMA-GΔ1306□S	4.80	14.40	ASD-B2-0721-F	5.10	15.30
			900	ECMA-GΔ1309□S	7.50	22.50	ASD-B2-1021-F	7.30	21.90

Note:

- (□) at the ends of the servo drive model names are for optional configurations.  
For the actual model name, please refer to the ordering information of the actual purchased product.
- (Δ) in the model names are for encoder resolution types. Δ = 1: Incremental type, 20-bit; Δ = 2: Incremental type, 17-bit; Δ = 3: 2500 ppr; Δ = M: Magnet type. The listed motor model name is for information searching, please contact to your local distributors for actual purchased product.
- (□) in the model names represents brake or keyway oil seal.  
The above table shows the specification of servo drive which has triple rated current. For detailed specification of the servo motor and servo drive, please refer to Appendix A.

### 1.4 Each Part of the Servo Drive

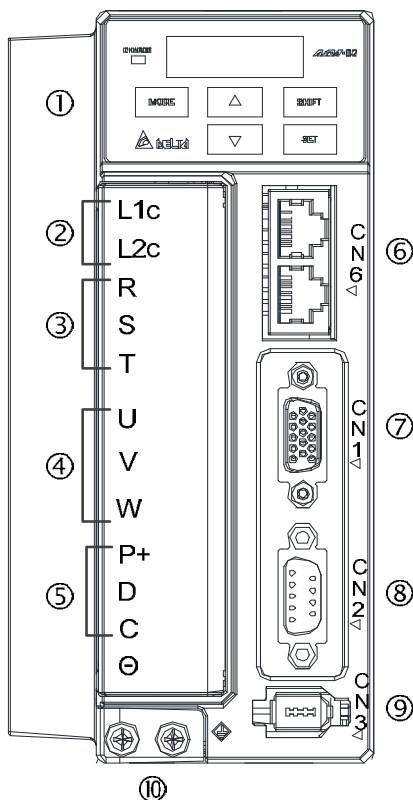

1

- ① **Heat sink:**  
Used to secure servo drive and for heat dissipation.
- ② **Control Circuit Terminal (L1c ~ L2c):**  
Used to connect 200 ~ 230 VAC, 50 / 60 Hz 1-phase / 3-phase VAC supply.
- ③ **Main Circuit Terminal (R, S, T):**  
Used to connect 200 ~ 230 V, 50 / 60 Hz commercial power supply.
- ④ **Servo Motor Output (U, V, W):**  
Used to connect servo motor. Never connect the output terminal to main circuit power.  
The AC servo drive may be destroyed beyond repair if incorrect cables are connected to the output terminals.
- ⑤ **Regenerative Resistor:**
  - (1) When using an external regenerative resistor, connect P⊕ and C to the regenerative resistor and ensure that the circuit between P⊕ and C is open.
  - (2) When using the internal regenerative resistor, ensure that the circuit between P⊕ and D is closed and the circuit between P⊕ and C is open
- ⑥ **CN6: DMCNET Connector:** Communication port for DMCNET communication.
- ⑦ **CN1: I/O Interface:** Used to connect external controller (PLC) or control I/O signal.
- ⑧ **CN2: Encoder Interface:** Used to connect encoder of servo motor.
- ⑨ **CN3: Serial Communication Interface:** It is controlled by MODBUS and supports RS-232. It can be connected to controllers.
- ⑩ **Ground Terminal:** Used to connect grounding wire of power supply and servo motor. Please connect it properly to avoid electric shock.

(This page is intentionally left blank.)

1

# Installation

# 2

This chapter allows you to properly install the device. Please follow the instruction mentioned in this chapter during installation. Information about specification of circuit breaker, fuse, EMI filter selection, and selection of regenerative resistor are also included.

---

2.1	Notes	2-2
2.2	Ambient Conditions of Storage	2-2
2.3	Ambient Conditions of Installation	2-2
2.4	Installation Direction and Space	2-3
2.5	Specification of Circuit Breaker and Fuse	2-5
2.6	EMI Filter Selection	2-5
2.7	Selection of Regenerative Resistor	2-7

## 2.1 Notes

Please pay special attention to the following:

- Do not strain the cable connection between the servo drive and the servo motor.
- Make sure each screw is tightened when fixing the servo drive.
- The motor shaft and the ball screw should be parallel.
- If the connection between the servo drive and the servo motor is over 20 meters, please thicken the connecting wire, UVW as well as the encoder cable.
- Tighten the four screws that fix the motor.

## 2.2 Ambient Conditions of Storage

Before the installation, this product has to be kept in the shipping carton. In order to retain the warranty coverage and for the maintenance, please follow the instructions below when storage, if the product is not in use temporarily:

- Store the product in a dry and dust-free location.
- Store the product within an ambient temperature range of -20°C to +65°C.
- Store the product within a relative humidity range of 0% to 90% and a non-condensing environment.
- Avoid storing the product in the environment of corrosive gas and liquid.
- It is better to store the product in the shipping carton and put it on the shelf or working platform.

## 2.3 Ambient Conditions of Installation

The most appropriate temperature of this servo drive is between 0°C and 55°C. If it is over 45°C, please place the product in a well-ventilated environment so as to ensure its performance. If the product is installed in an electric box, make sure the size of the electric box and its ventilation condition will not overheat and endanger the internal electronic device. Also, pay attention to the vibration of the machine. Check if the vibration will influence the electronic device of the electric box. Besides, the ambient conditions should be:

- No over-heat device.
- No water drop, vapor, dust or oily dust.
- No corrosive and inflammable gas or liquid.
- No airborne dust or metal particles.
- With solid foundation and no vibration.
- No interference of electromagnetic noise.

The ambient temperature of the motor is between 0°C and 40°C and the ambient conditions should be:

- No over-heat device.
- No water drop, vapor, dust or oily dust.
- No corrosive and inflammable gas or liquid.
- No airborne dust or metal particles.

## 2.4 Installation Direction and Space

### Notes:

- Incorrect installation may result in a drive malfunction or premature failure of the drive and motor.
- In order to ensure the drive can be well-cooled and the environment is well circulated, sufficient space between adjacent object and the baffle is needed.
- Ensure all ventilation holes are not obstructed. Do not install the drive in a horizontal direction or malfunction and damage will occur.

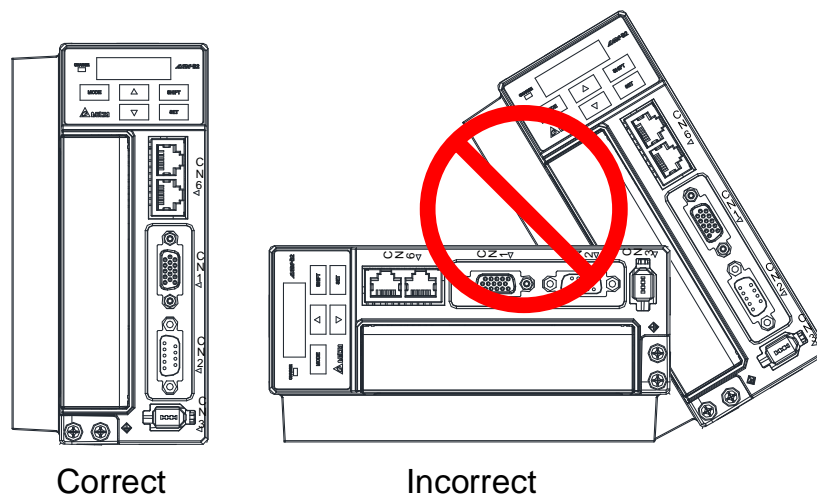

### Installing servo drives:

ASDA-B2-F series servo drive should be mounted perpendicular to a dry and solid surface that conforms to NEMA standards. To ensure a well-ventilated environment, sufficient space between adjacent object and the baffle is required. 50 mm (approx. 2 inch.) of clearance is suggested. If wiring is needed, please leave the space for it. Please note that the rack or the surface shall conduct heat well, so as to avoid the overheating of servo drive.

**Installing motors:**

ECMA series motors shall be mounted to the mounting surface which is dry and stable. Please make sure the environment is well-ventilated and the motor is properly grounded.

For the dimensions and specifications of the servo drive and servo motor, please refer to Appendix A -Specifications.

**Mounting distances and ventilation:**

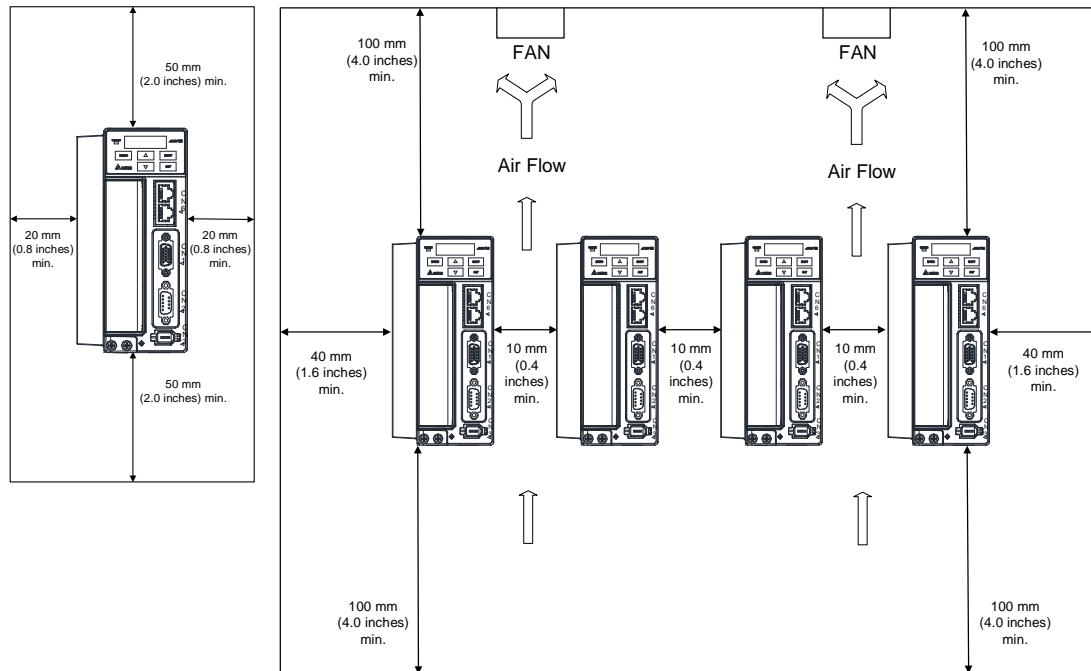

To lower the air resistance and ensure the drive is well ventilated, please follow the instructions during installation and leaving sufficient space as suggested.

**Note:**

The above diagrams are not in equal proportion. Please refer to the annotation

## 2.5 Specification of Circuit Breaker and Fuse

**Caution: Please use the fuse and circuit breaker that is recognized by UL/CSA.**

Servo Drive Model	Circuit Breaker	Fuse (Class T)
Operation Mode	General	General
ASD-B2-0121-F	5A	5A
ASD-B2-0221-F	5A	6A
ASD-B2-0421-F	10A	10A
ASD-B2-0721-F	10A	20A
ASD-B2-1021-F	15A	25A
ASD-B2-1521-F	20A	40A
ASD-B2-2023-F	30A	50A
ASD-B2-3023-F	30A	70A

Note :

If the servo drive equips with earth leakage circuit breaker for avoiding electric leakage, please choose the current sensitivity which is over 200 mA and can continue up to 0.1 seconds.

## 2.6 EMI Filter Selection

Item	Power	Servo Drive Model	Recommended EMI Filter		Foot Print
			1PH	3PH	
1	100 W	ASD-B2-0121-F	RF007S21AA	RF022M43AA	N
2	200 W	ASD-B2-0221-F	RF007S21AA	RF022M43AA	N
3	400 W	ASD-B2-0421-F	RF007S21AA	RF022M43AA	N
4	750 W	ASD-B2-0721-F	RF007S21AA	RF022M43AA	N
5	1000 W	ASD-B2-1021-F	RF015B21AA	RF075M43BA	N
6	1500 W	ASD-B2-1521-F	RF015B21AA	RF075M43BA	N
7	2000 W	ASD-B2-2023-F	-	RF037B43BA	N
8	3000 W	ASD-B2-3023-F	-	RF037B43BA	N

### EMI Filter Installation

All electronic equipment (including servo drive) generates high or low frequency noise during operation and interfere the peripheral equipment via conduction or radiation. With EMI Filter and the correct installation, much interference can be eliminated. It is suggested to use Delta's EMI Filter to suppress the interference better.

When installing servo drive and EMI Filter, please follow the instructions of the user manual and make sure it meets the following specifications.

1. EN61000-6-4 (2001)
2. EN61800-3 (2004) PDS of category C2
3. EN55011+A2 (2007) Class A Group 1

# 2

### General Precaution

In order to ensure the best performance of EMI Filter, apart from the instructions of servo drive installation and wiring, please follow the precautions mentioned below:

1. The servo drive and EMI Filter should be installed on the same metal plate.
2. When installing servo drive and EMI Filter, the servo drive should be installed above the EMI Filter.
3. The wiring should be as short as possible.
4. The metal plate should be well grounded.
5. The servo drive and the metal cover of EMI Filter or grounding should be firmly fixed on the metal plate. Also, the contact area should be as large as possible.

### Motor Cable Selection and Installation Precautions

The selection of motor cables and installation affect the performance of EMI Filter. Please follow the precautions mentioned below.

1. Use the cable that has braided shielding (The effect of double shielding is better)
2. The shield on both sides of the motor cable should be grounded in the shortest distance and the largest contact area.
3. The protective paint of the U-shape saddle and metal plate should be removed in order to ensure the good contact. Please see Fig. 1.
4. It should have correct connection between the braided shielding of the motor cable and the metal plate. The braided shielding on both sides of the motor cable should be fixed by the U-shape saddle and metal plate. Please see Fig. 2 for the correct connection.

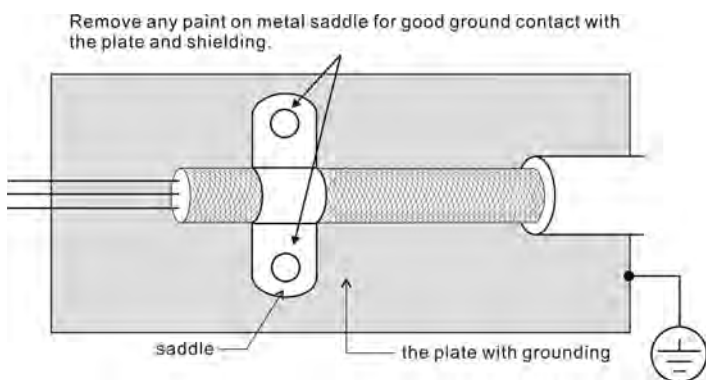

Fig.1

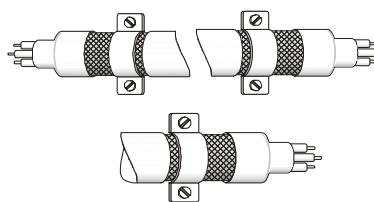

Fig. 2

## 2.7 Selection of Regenerative Resistor

When the direction of pull-out torque is different from the rotation, it means the electricity is sent back to the servo drive from the load-end. It becomes the capacitance of DC Bus and increases the voltage. When the voltage increases to a specific value, the come-back electricity can only be consumed by regenerative resistor. There is a built-in regenerative resistor in the servo drive. Users can also use the external regenerative resistor if needed.

### Specification of built-in regenerative resistor provided by ASDA-B2-F Series

Servo Drive (KW)	Specification of built-in regenerative resistor		*1The capacity of built-in regenerative resistor (Watt)	Minimum allowable resistance (Ohm)
	Resistance (P1-52) (Ohm)	Capacity (P1-53) (Watt)		
0.1	--	--	--	60
0.2	--	--	--	60
0.4	100	60	30	60
0.75	100	60	30	60
1.0	40	60	30	30
1.5	40	60	30	30
2.0	20	100	50	15
3.0	20	100	50	15

\*1The capacity of built-in regenerative resistor (average value) is 50% of the rated capacity of the built-in regenerative resistor. The capacity of the external regenerative resistor is the same as the built-in one.

When the regenerative resistor exceeds the capacity of built-in regenerative resistor, the external regenerative resistor should be applied. Please pay special attention to the following when using the regenerative resistor.

1. Please correctly set up the resistance (P1-52) and capacity (P1-53) of regenerative resistor. Or it might influence the performance of this function.
2. If users desire to use the external regenerative resistor, please make sure the applied value should not be smaller than the value of built-in regenerative resistor. In general application, more than one resistor will be serial connected. If the value (from serial connected resistors) exceeds the setting range, users can reduce the value by parallel connecting the resistor. If users desire to connect it in parallel to increase the power of regenerative resistor, please make sure the capacitance meets the requirements.
3. In natural environment, if the capacity of regenerative resistor (the average value) is within the rated capacity, the temperature of the capacitance will increase to 120°C or even higher (under the condition of regenerative energy keeps existing). For safety concerns, please apply the method of forced cooling in order to reduce the temperature of regenerative resistor. Or, it is suggested to use the regenerative resistor which is equipped with thermal switches. Please contact the distributors for load characteristics of the regenerative resistor.

When using the external regenerative resistor, the resistor should connect to P, C terminal and the contact of P, D terminal should be opened. It is recommended to choose the above mentioned capacitance. For easy calculation of regenerative resistor capacity, except the energy consumed by IGBT, two ways are provided to select the capacity of external regenerative resistor according to the selected linear motor or rotary motor.

(1) Regenerative Power Selection

(a) When the external load on torque does not exist

If the motor operates back and forth, the energy generated by the brake will go into the capacitance of DC bus. When the voltage of the capacitance exceeds a specific value, the redundant energy will be consumed by regenerative resistor. Two ways of selecting regenerative resistor are provided here. The table below provides the energy calculation method. Users can refer to it and calculate the selected regenerative resistor.

Servo Drive (kW)	Motor	Rotor Inertia J (x 10 <sup>-4</sup> kg.m <sup>2</sup> )	Regenerative power from empty load 3000r/min to stop Eo (joule)	The maximum regenerative power of capacitance Ec (joule)	
Low Inertia	0.1	ECMA-CΔ040F□□	0.021	0.10	4.21
		ECMA-CΔ0401□□	0.037	0.18	4.21
	0.2	ECMA-CΔ0602□□	0.177	0.87	5.62
	0.4	ECMA-CΔ0604□□	0.277	1.37	8.42
		ECMA-CΔ0804□□	0.68	3.36	8.42
	0.75	ECMA-CΔ0807□□	1.13	5.59	17.47
		ECMA-CΔ0907□□	1.93	9.54	17.47
	1.0	ECMA-CΔ0910□□	2.62	12.96	21.22
		ECMA-CΔ1010□□	2.65	13.1	21.22
	2.0	ECMA-CΔ1020□□	4.45	22.0	25.58
3.0	ECMA-CΔ1330□□	12.7	62.80	25.58	
Medium Inertia	0.4	ECMA-EΔ1305□□	8.17	40.40	8.42
	1.0	ECMA-EΔ1310□□	8.41	41.59	21.22
	1.5	ECMA-EΔ1315□□	11.18	55.29	25.58
	2.0	ECMA-EΔ1320□□	14.59	72.15	25.58
		ECMA-EΔ1820□□	34.68	171.49	25.58
	3.0	ECMA-EΔ1830□□	54.95	217.73	31.20
Medium - High Inertia	1.0	ECMA-FΔ1308□□	13.6	67.25	21.22
	2.0	ECMA-FΔ1313□□	20.0	98.90	25.58
	3.0	ECMA-FΔ1830□□	54.95	217.73	28
High Inertia	0.4	ECMA-GΔ1303□□	8.17	17.96	8.42
	0.75	ECMA-GΔ1306□□	8.41	18.48	17.47
	1.0	ECMA-GΔ1309□□	11.18	24.57	21.22

$E_o = J * W_r^2 / 182$  (joule),  $W_r$ : r/min

Assume that the load inertia is N times to the motor inertia and the motor decelerates from 3000 r/min to 0, its regenerative energy is (N+1) x Eo. The consumed regenerative resistor is (N+1) x Eo - Ec joule. If the cycle of back and forth operation is T sec, then the power of regenerative resistor it needs is  $2 \times ((N+1) \times E_o - E_c) / T$ .

Steps	Item	Calculation and Setting Method
1	Set the capacity of regenerative resistor to the maximum	Set P1-53 to the maximum value
2	Set T cycle of back and forth operation	Enter by the user
3	Set the rotational speed wr	Enter by the user or read via P0-02
4	Set the load/motor inertia ratio N	Enter by the user or read via P0-02
5	Calculate the maximum regenerative energy Eo	$E_o = J * w_r^2 / 182$
6	Set the absorbable regenerative energy Ec	Refer to the above table
7	Calculate the needful capacitance of regenerative resistor	$2 \times ((N+1) \times E_o - E_c) / T$

Take the motor (400 W with frame size 60) as the example, the cycle of back and forth operation is  $T = 0.4$  sec, the maximum speed is 3000 r/min and the load inertia is 7 times to the motor inertia. Then, the needful power of regenerative resistor is  $2 \times ((7+1) \times 1.37 - 8) / 0.4 = 14.8$  W. If it is smaller than the built-in capacity of regenerative resistor, the built-in 60W regenerative resistor will do. Generally speaking, when the need of the external load inertia is not much, the built-in regenerative is enough. The diagram below describes the actual operation. The smaller power of the regenerative resistor it is, the more energy it accumulates and the higher temperature it will be. When the temperature is higher than a specific value, AL005 occurs.

(b) If the external load torque exists, the motor is in reverse rotation.

Usually, the motor is in forward rotation, which means the torque output direction of the motor is the same as the rotation direction. However, in some applications, the direction of torque output is different from the rotation. In this situation, the motor is in reverse rotation. The external energy goes into the servo drive through the motor. The diagram below is one example. When the external force direction is the same as the moving direction, the servo system has to use the force of the opposite direction to keep the speed and stability. Huge amount of energy will return to the servo drive at the moment. When DC-BUS is full and unable to store the regenerative energy, the energy will be led to regenerative resistor and consumed.

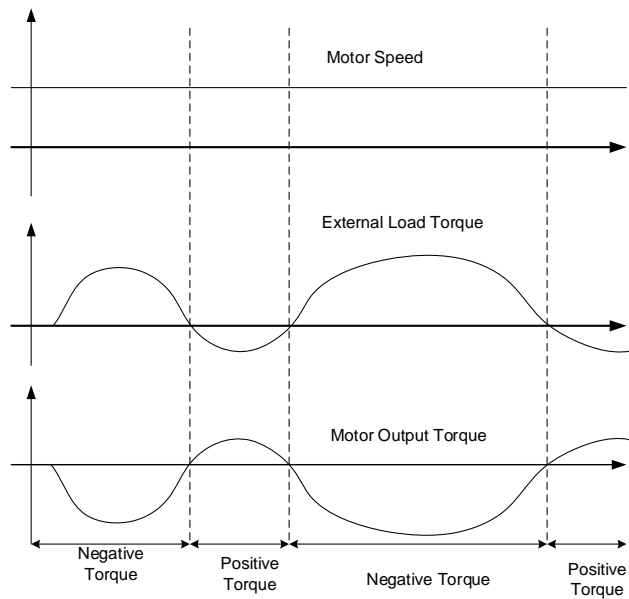

Negative torque:  $T_L \times W_r$        $T_L$ : external load torque

For safety reasons, please calculate it by considering the safest situation.

For example, when the external load torque is +70% rated torque and the rotation reaches 3000 r/min, then take 400W (the rated torque is 1.27 Nt-m) as the example, users have to connect the regenerative resistor which is  $2 \times (0.7 \times 1.27) \times (3000 \times 2 \times \pi / 60) = 560$  W, 60  $\Omega$ .

(2) Simple Selection

Choose the appropriate regenerative resistor according to the allowable frequency and empty load frequency in actual operation. The so-called empty allowable frequency is the frequency of continuous operation when the servo motor runs from 0 r/min to the rated speed and then decelerates from the rated speed to 0r/min within the shortest time. The following table lists the allowable frequency when the servo drive runs without load (times/min).

Allowable frequency when the servo drive runs without load (times/min) and uses a built-in regenerative resistor								
Motor Capacity	600 W	750 W	900 W	1.0 kW	1.5 kW	2.0 kW	2.0 kW	3.0 kW
Servo Motor	06	07	09	10	15	20	20	30
ECMA□□C	-	312	-	137	-	83 (F100)		-
ECMA□□E	-	-	-	42	32	24 (F130)	10 (F180)	11
ECMA□□G	42	-	31	-	-	-	-	-

When the servo motor runs with load, the allowable frequency will be different according to different load inertia or speed. The following is the calculation method.

“m” represents load / motor inertia ratio.

$$\text{Allowable frequency} = \frac{\text{Allowable frequency when servo motor run without load}}{m + 1} \times \left( \frac{\text{Rated speed}}{\text{Operating speed}} \right)^2 \frac{\text{times}}{\text{min.}}$$

The comparison table of external regenerative resistor is provided below. Please choose the appropriate regenerative resistor according to the allowable frequency.

The table below describes the suggested allowable frequency (times/min) of regenerative resistor when the servo drive runs without load.

Allowable frequency of regenerative resistor when the servo drive runs without load (times/min)								
Suggested Regenerative Resistor	ECMA□□C							
	Motor Capacity	100 W	200 W	400 W (F60)	400 W (F80)	750 W	1.0 kW	2.0 kW
		01	02	04	04	07	10	20
200 W 80 Ω	32793	6855	4380	1784	1074	458	273	
400 W 40 Ω	-	-	-	-	-	916	545	
1 kW 30 Ω	-	-	-	-	-	-	1363	

Allowable frequency of regenerative resistor when the servo drive runs without load (times/min)							
Suggested Regenerative Resistor	ECMA□□E						
	Motor Capacity	0.5 kW	1 kW	1.5 kW	2.0 kW	2.0 kW	3.0 kW
		05	1.0	15	20	20	30
200 W 80 Ω	149	144	109	83	35	22	
400 W 40 Ω	-	289	217	166	70	44	
1k W 30 Ω	-	-	-	416	175	110	

Allowable frequency of regenerative resistor when the servo drive runs without load (times/min)				
Suggested Regenerative Resistor	Motor Capacity	ECMA□□G		
		0.3 kW	0.6 kW	0.9 kW
		03	06	09
200 W 80 Ω		149	144	109
400 W 40 Ω		-	-	217

If watt is not enough when using regenerative resistor, connecting the same regenerative resistor in parallel can increase the power.

**Dimensions of Regenerative Resistor**

Delta Part Number: BR400W040 (400 W 40 Ω)

L1	L2	H	D	W	MAX. WEIGHT (g)
265	250	30	5.3	60	930

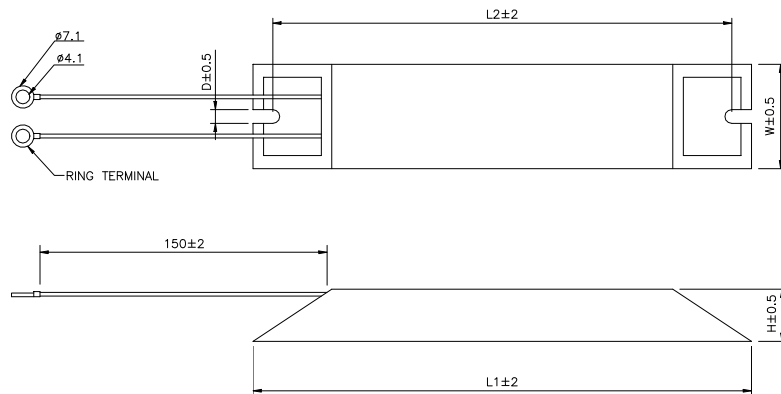

Delta Part Number: BR1K0W020 (1 kW 20 Ω)

L1	L2	H	D	W	MAX. WEIGHT(g)
400	385	50	5.3	100	2800

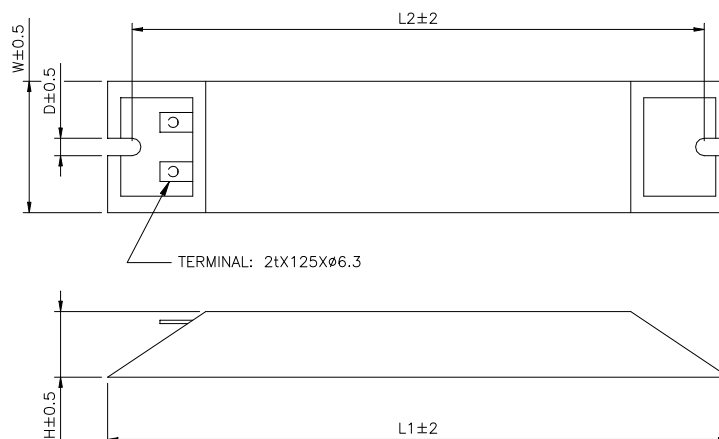

**Note:**  
Please refer to Appendix B for selection of regenerative resistor.

(This page is intentionally left blank.)

2

# Wiring

# 3

This chapter explains the wiring methods of the power circuit and connector definitions. The standard wiring diagrams for each control mode are also provided.

3.1	Connections .....	3-2
3.1.1	Connecting to Peripheral Devices .....	3-2
3.1.2	Connectors and Terminals of Servo Drive .....	3-3
3.1.3	Wiring Method .....	3-4
3.1.4	Specification of Motor Power Cable .....	3-5
3.1.5	Specification of Encoder Cable Connector .....	3-7
3.1.6	Selection of Wiring Rod .....	3-10
3.2	Basic Wiring .....	3-11
3.2.1	200 W or models below (withtout built-in regenerative resistor nor fan) ..	3-11
3.2.2	400 W ~ 750 W models (with built-in regenerative resistor but no fan) ...	3-12
3.2.3	1 kW ~ 1.5 kW models (with built-in regenerative resistor and fan) .....	3-13
3.2.4	2 kW ~ 3 kW models (with built-in regenerative resistor and fan) .....	3-14
3.3	I / O Signal (CN1) Connection .....	3-15
3.3.1	I / O Signal (CN1) Connector Terminal Layout .....	3-15
3.3.2	Signals Explanation of Connector CN1 .....	3-16
3.3.3	Wiring Diagrams (CN1) .....	3-18
3.3.4	DI and DO Signal Specified by Users .....	3-20
3.4	CN2 Connector .....	3-21
3.5	Wiring of CN3 Connector .....	3-23
3.6	CN6 Connector (DMCNET) .....	3-24
3.7	Standard Connection Example .....	3-26

### 3.1 Connections

#### 3.1.1 Connecting to Peripheral Devices

3

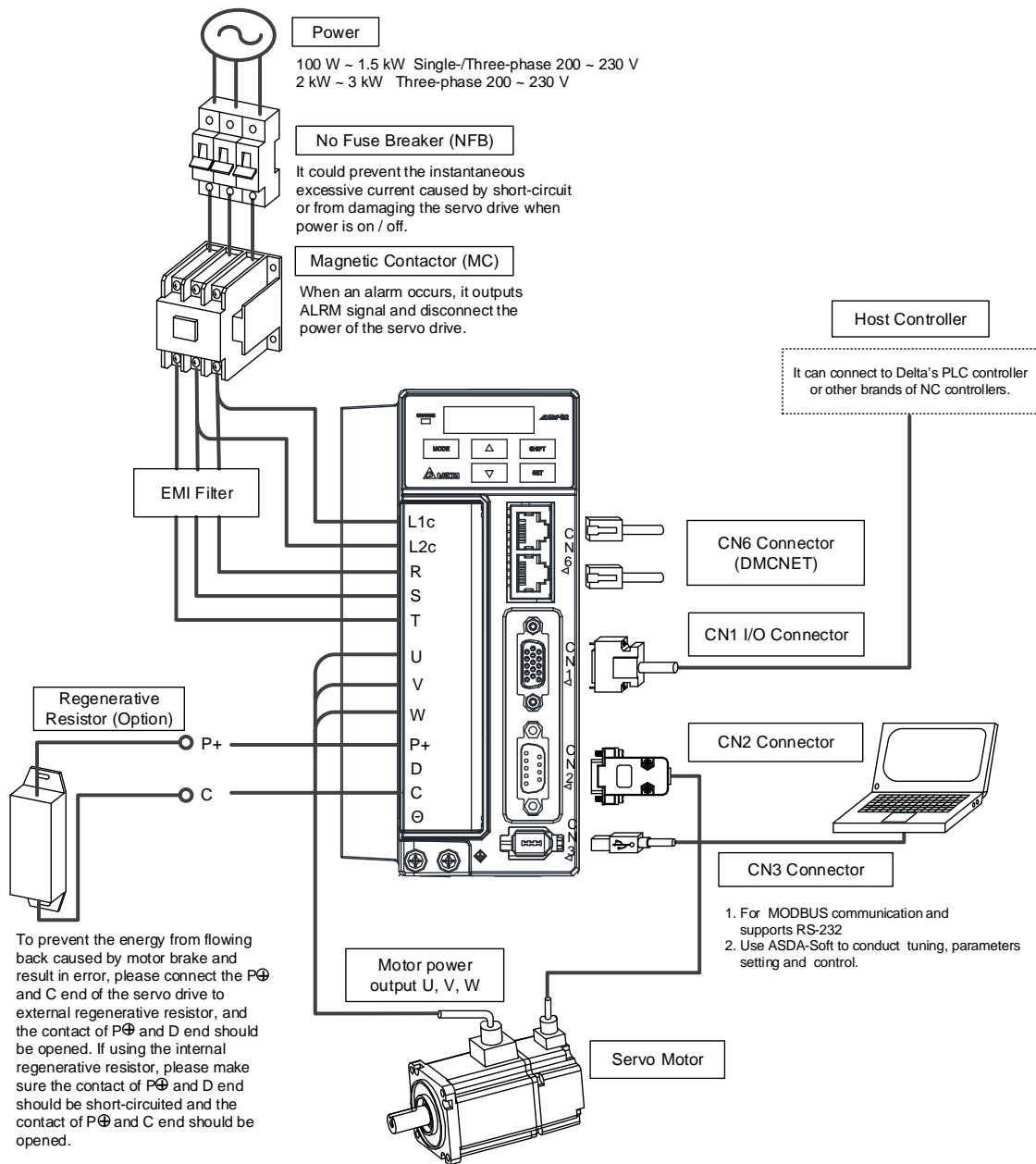

Installation notes:

1. Check if the power and wiring among R, S, T and L1c, L2c are correct.
2. Please check if the output terminal U, V, W of the servo motor is correctly wired. Incorrect wiring may disable the operation of the motor or cause malfunction, triggering AL031 (Incorrect wiring of the motor power line U, V, W, GND).
3. When applying to the external regenerative resistor, the contact between P<sup>+</sup> and D should be opened and the external regenerative resistor should connect to terminal P<sup>+</sup> and C. When applying to the internal regenerative resistor, the contact between P<sup>+</sup> and D should be short-circuited and the contact between P<sup>+</sup> and C should be opened.
4. When an alarm occurs or the system is in emergency stop status, use ALARM or WARN to output and disconnect the power of magnetic contactor in order to disconnect the power of servo drive.

### 3.1.2 Connectors and Terminals of Servo Drive

Terminal Signal	Name	Description		
L1c, L2c	Power input of the control circuit	Connect to single-phase AC power (Select the appropriate voltage specification according to the product.)		
R, S, T	Power input of the main circuit	Connect to three-phase AC power (Select the appropriate voltage specification according to the product.)		
U, V, W FG	Motor cable	Connect to the servo motor		
		Terminal Symbol	Wire Color	Description
		U	Red	Three-phase main power cable of the motor.
		V	White	
		W	Black	
FG	Green	Connect to ground terminal ( $\oplus$ ) of the servo drive.		
P $\oplus$ , D, C, $\ominus$	Regenerative resistor terminal, braking unit, or P $\oplus$ and $\ominus$ .	Use internal resistor	The contact between P $\oplus$ and D end should be short-circuited; contact between P $\oplus$ and C end should be opened.	
		Use external resistor	Connect P $\oplus$ , C ends to the resistor and the contact between P $\oplus$ and D end should be opened.	
		Use external braking unit	P $\oplus$ and P $\ominus$ of the brake unit should connect to the resistor. The contact between P $\oplus$ and D and P $\oplus$ and C should be opened. P $\oplus$ connects to the positive end of V_BUS voltage; $\ominus$ connects to the negative end of V_BUS voltage.	
$\oplus$	Ground terminal	Connect to the ground wire of the power and servo motor.		
CN1	I/O connector (Option)	Connect to the host controller. Please refer to section 3.3.		
CN2	Connector for encoder (Option)	Connect to the encoder of the motor. Please refer to section 3.4.		
CN3	Connector for communication (Option)	Connect to RS-232. Please refer to section 3.5.		
CN6	DMCNET Connector	RJ45 connector. Please refer to section 3.6.		

Pay special attention to the followings when wiring:

1. When the power is cut off, do not touch R, S, T and U, V, W since the capacitance inside the servo drive still contains huge amount of electric charge. Wait until the charging light is off.
2. Separate R, S, T and U, V, W from the other wires. The interval should be at least 30 cm (11.8 inches).
3. If the wire of CN2 is not long enough, please use shielded twisted-pair cable which cannot exceed 20 meters (65.62 inches). If it exceeds 20 meters, please choose the bigger wire diameter of signal cable to ensure it will not cause signal fading.
4. When selecting the wire rod, please refer to Section 3.1.6.

3

3.1.3 Wiring Method

There are two types of wiring method, single-phase and three-phase. In the diagram below, Power On is contact **a**, Power Off and ALRM\_RY are contact **b**. MC is the coil of magnetic contactor and self-remaining power and is the contact of main power circuit.

- Wiring Method of Single-phase Supply (suitable for 1.5 kW and models below 1.5 kW)

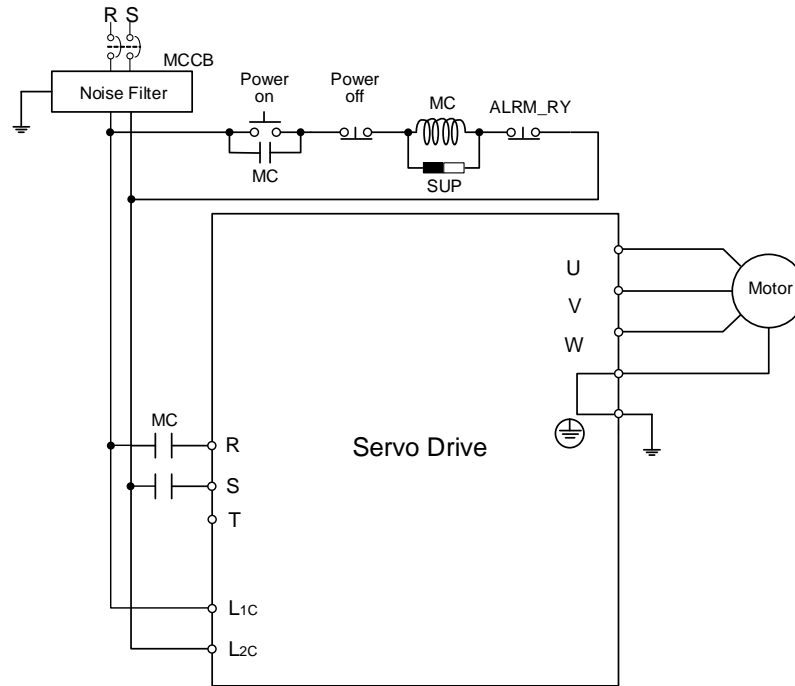

- Wiring Method of Three-phase Power Supply (suitable for all series)

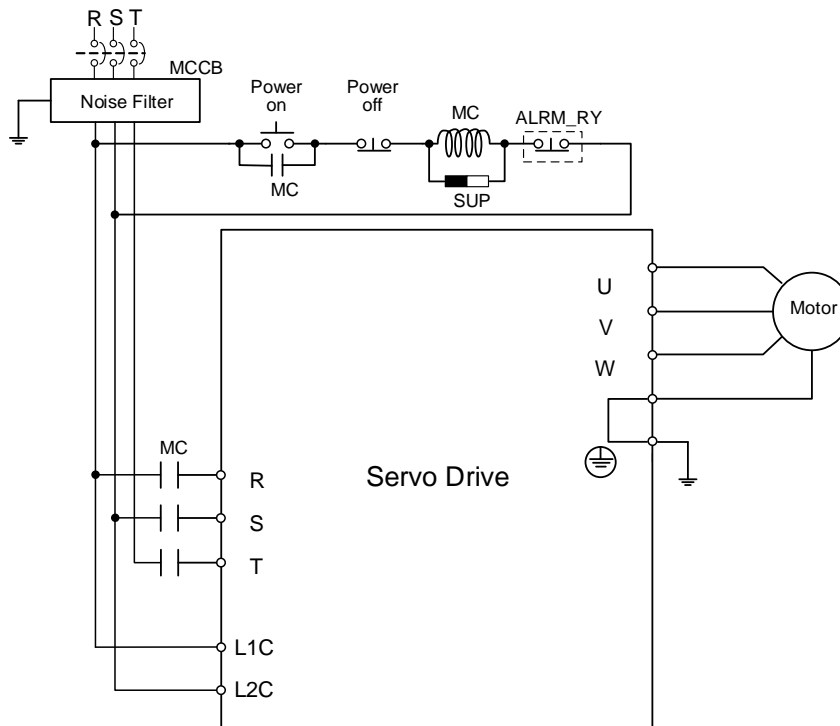

3.1.4 Specification of Motor Power Cable

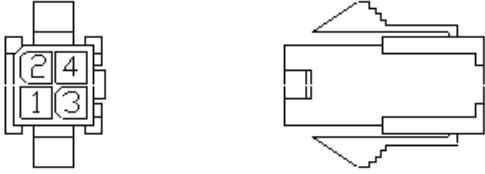
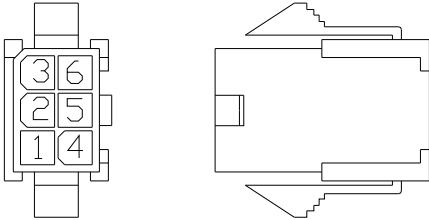
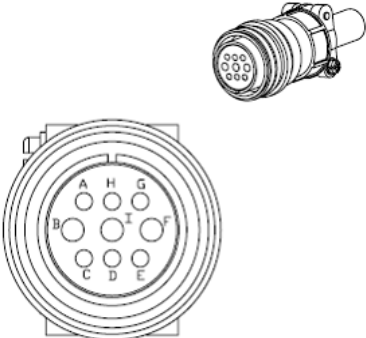
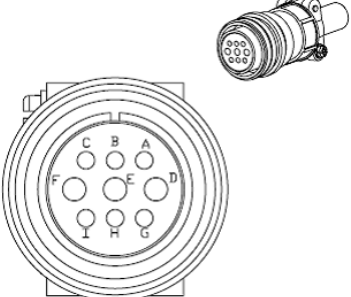
Motor Model	U, V, W / Connector of Brake	Terminal Definition
<p>ECMA-C1040F□S (50 W)                      ECMA-CΔ0401□S (100 W)                      ECMA-CΔ0602□S (200 W)                      ECMA-CΔ0604□S (400 W)                      ECMA-CΔ0604□H (400 W)                      ECMA-CΔ0804□7 (400 W)                      ECMA-CΔ0807□S (750 W)                      ECMA-CΔ0807□H (750 W)                      ECMA-CΔ0907□S (750 W)                      ECMA-CΔ0910□S (1000 W)</p>		<p>A</p>
<p>ECMA-C1040F□S (50 W)                      ECMA-CΔ0401□S (100 W)                      ECMA-CΔ0602□S (200 W)                      ECMA-CΔ0604□S (400 W)                      ECMA-CΔ0604□H (400 W)                      ECMA-CΔ0804□7 (400 W)                      ECMA-CΔ0807□S (750 W)                      ECMA-CΔ0807□H (750 W)                      ECMA-CΔ0907□S (750 W)                      ECMA-CΔ0910□S (1000 W)</p> <p>*□ : with brake</p>		<p>B</p>
<p>ECMA-GΔ1303□S (300 W)                      ECMA-EΔ1305□S (500 W)                      ECMA-GΔ1306□S (600 W)                      ECMA-FΔ1308□S (850 W)                      ECMA-GΔ1309□S (900 W)                      ECMA-CΔ1010□S (1000 W)                      ECMA-EΔ1310□S (1000 W)                      ECMA-FΔ1313□S (1300 W)                      ECMA-EΔ1315□S (1500 W)                      ECMA-FΔ1318□S (1800 W)                      ECMA-CΔ1020□S (2000 W)                      ECMA-EΔ1320□S (2000 W)                      ECMA-CΔ1330□4 (3000 W)</p>		<p>C</p>
<p>ECMA-EΔ1820□S (2000 W)                      ECMA-EΔ1830□S (3000 W)                      ECMA-FΔ1830□S (000 W)</p>		<p>D</p>

Wiring Name	U (Red)	V (White)	W (Black)	CASE GROUND (Green)	BRAKE1 (Yellow)	BRAKE2 (Blue)
Terminal Definition A	1	2	3	4	-	-
Terminal Definition B	1	2	4	5	3	6
Terminal Definition C	F	I	B	E	G	H
Terminal Definition D	D	E	F	G	A	B

When selecting the wire rod, please choose 600 V PVC cable and the length should be no longer than 30 m. If the length exceeds 30 m, please take the received voltage into consideration when selecting the wire size. Please refer to Section 3.1.6 for wire rod selection.

Note:

1. No polarity for brake coil, the wiring name is BRAKE1 & BRAKE2.
2. Power for brake is 24 V<sub>DC</sub>. Never share it with the power of control signal V<sub>DD</sub>.
3. Box, (□) in servo motor model represents brake or keyway / oil seal.
4. Triangle, (△) in servo motor model represents encoder type. Please see Chapter 1 for detail.

### 3.1.5 Specification of Encoder Cable Connector

Encoder Connection (Diagram 1):

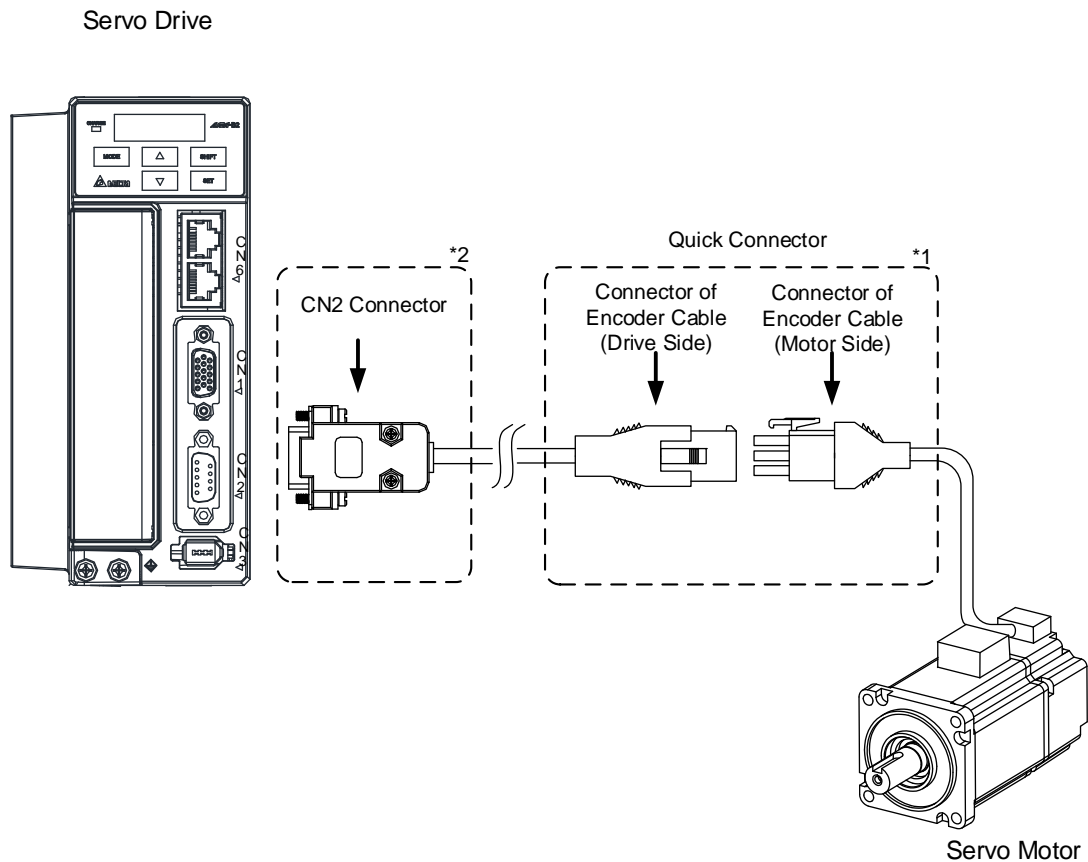

**Note:**

This diagram shows the connection between the servo drive and the motor encoder, which is not drawn by the practical scale. The specification will change subject to the selected servo drive and motor model.

1. Please refer to the Section of Specification and Definition of Encoder Connector.
2. Please refer to Section 3.4 CN2 Connector.

Motor Model	Connector of Encoder Cable
ECMA-C1040F□S (50 W) ECMA-C△0401□S (100 W) ECMA-C△0602□S (200 W) ECMA-C△0604□S (400 W) ECMA-C△0604□H (400 W) ECMA-C△0804□7 (400 W) ECMA-C△0807□S (750 W) ECMA-C△0807□H (750 W) ECMA-C△0907□S (750 W) ECMA-C△0910□S (1000 W)	

# 3

## Specification and Definition of Encoder Connector:

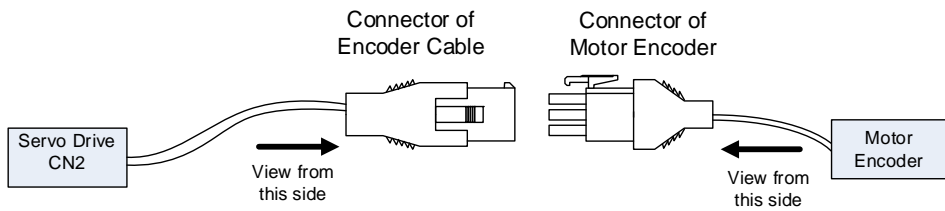

(Encoder types are 17-bit and 20-bit):

<b>1</b> Blue T+	<b>2</b> Reserved	<b>3</b> Reserved
<b>4</b> Blue/Black T-	<b>5</b> Reserved	<b>6</b> Reserved
<b>7</b> Red/Red & white DC+5V	<b>8</b> Black/Black & white GND	<b>9</b> Shield

The wire color of the servo drive is for reference only. Please refer to the real object.

<b>3</b> Reserved	<b>2</b> -	<b>1</b> White T+
<b>6</b> Reserved	<b>5</b> -	<b>4</b> White/Red T-
<b>9</b> Shield	<b>8</b> Blue GND	<b>7</b> Brown DC+5V

(Encoder type is 2500 ppr, 33 bits):

<b>3</b> Reserved	<b>2</b> Reserved	<b>1</b> White T+
<b>6</b> Reserved	<b>5</b> Reserved	<b>4</b> White/Red T-
<b>9</b> Shield	<b>8</b> Blue GND	<b>7</b> Brown DC+5V

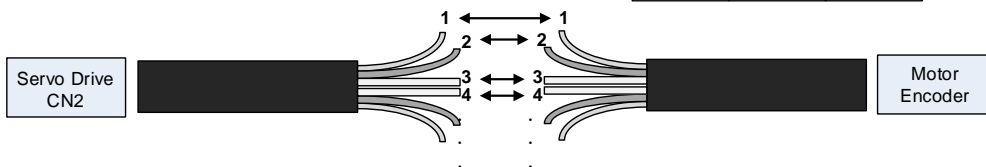

If not using housing and directly wire the cores, please follow the corresponding core number for wiring. For example, core number 1 from the servo drive CN2 should connect to core number 1 from the motor encoder; core number 2 from the servo drive CN2 should connect to core number 2 from the motor encoder and so on. Please number the cores from the servo drive in order and then connect it to the encoder.

Encoder Connection (Diagram 2):

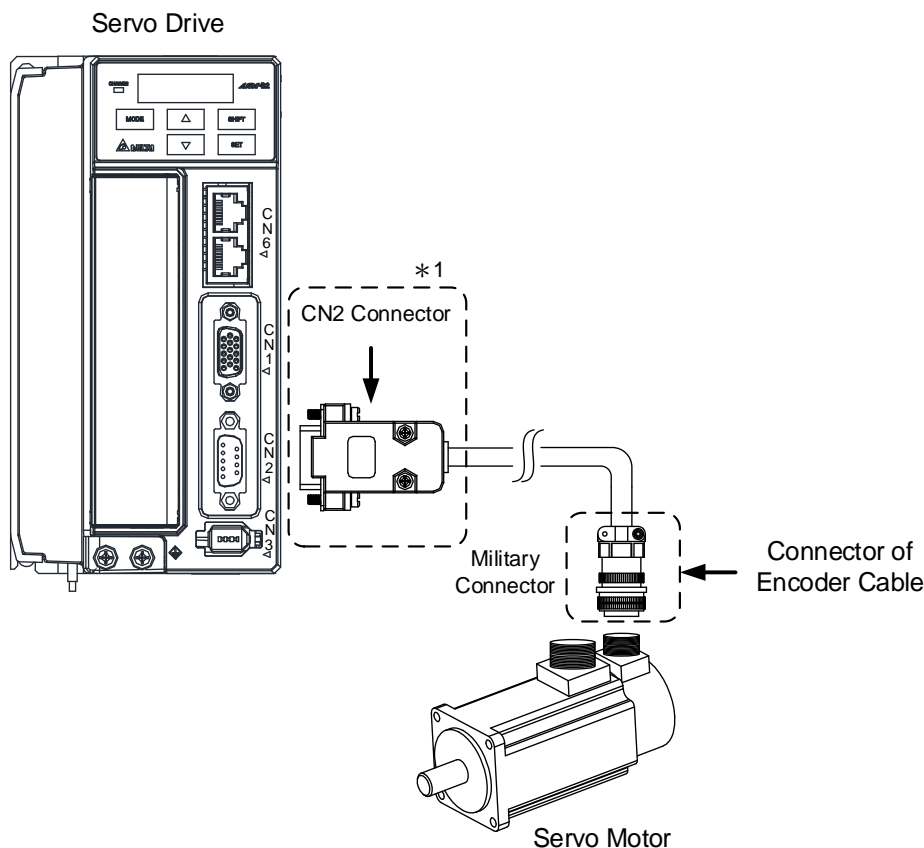

Note:

This diagram shows the connection between the servo drive and the motor encoder, which is not drawn by the practical scale. The specification will change subject to the selected servo drive and motor model.

1. Please refer to Section 3.4, CN2 Connector.

Motor Model	Connector of Encoder Cable																			
ECMA-G△1303□S (300 W) ECMA-E△1305□S (500 W) ECMA-G△1306□S (600 W) ECMA-F△1308□S (850 W) ECMA-G△1309□S (900 W) ECMA-C△1010□S (1000 W) ECMA-E△1310□S (1000 W) ECMA-F△1313□S (1300 W) ECMA-E△1315□S (1500 W) ECMA-F△1318□S (1800 W) ECMA-C△1020□S (2000 W) ECMA-E△1320□S (2000 W) ECMA-C△1330□4 (3000 W) ECMA-E△1820□S (2000 W)	<p>View from this side</p> <p>Military Connector</p>	<table border="1"> <thead> <tr> <th>Pin No.</th> <th>Terminal Identification</th> <th>Color</th> </tr> </thead> <tbody> <tr> <td>A</td> <td>T+</td> <td>Blue</td> </tr> <tr> <td>B</td> <td>T-</td> <td>Blue &amp; Black</td> </tr> <tr> <td>S</td> <td>DC+5V</td> <td>Red/Red &amp; White</td> </tr> <tr> <td>R</td> <td>GND</td> <td>Black/Black &amp; White</td> </tr> <tr> <td>L</td> <td>BRAID SHIELD</td> <td>-</td> </tr> </tbody> </table>	Pin No.	Terminal Identification	Color	A	T+	Blue	B	T-	Blue & Black	S	DC+5V	Red/Red & White	R	GND	Black/Black & White	L	BRAID SHIELD	-
Pin No.	Terminal Identification	Color																		
A	T+	Blue																		
B	T-	Blue & Black																		
S	DC+5V	Red/Red & White																		
R	GND	Black/Black & White																		
L	BRAID SHIELD	-																		

Please select shielded multi-core and the shielded cable should connect to the SHIELD end. Please refer to the description of Section 3.1.6.

Note:

1. Box, (□) in servo motor model represents brake or keyway / oil seal.
2. Triangle, (△) in servo motor model represents encoder type. Please refer to Chapter 1 for detail.

### 3.1.6 Selection of Wiring Rod

The recommended wire rods are shown as the following table.

Servo Drive and corresponding Servo Motor		Power Wiring - Wire Diameter mm <sup>2</sup> (AWG)			
		L1c, L2c	R, S, T	U, V, W	P <sup>+</sup> , C
ASD-B2-0121-F	ECMA-C1040F□S	1.3 (AWG16)	2.1(AWG14)	0.82(AWG18)	2.1(AWG14)
	ECMA-C△0401□S				
ASD-B2-0221-F	ECMA-C△0602□S				
ASD-B2-0421-F	ECMA-C△0604□S				
	ECMA-C△0604□H				
	ECMA-C△0804□7				
	ECMA-E△1305□S				
ASD-B2-0721-F	ECMA-G△1303□S				
	ECMA-F11305□S				
	ECMA-C△0807□S				
	ECMA-C△0807□H				
ASD-B2-1021-F	ECMA-C△0907□S				
	ECMA-G△1306□S				
	ECMA-C△0910□S				
	ECMA-C△1010□S				
ASD-B2-1521-F	ECMA-E△1310□S				
	ECMA-F△1308□S				
	ECMA-G△1309□S				
	ECMA-E△1315□S				
ASD-B2-2023-F	ECMA-C△1020□S				
	ECMA-E△1320□S				
	ECMA-E△1820□S				
ASD-B2-3023-F	ECMA-F11313□S				
	ECMA-F11318□S				
	ECMA-C△1330□4				
	ECMA-E△1830□S				
ASD-B2-3023-F	ECMA-E△1835□S				
	ECMA-F△1830□S				

Servo Drive Model	Encoder Wiring - Wire Diameter mm <sup>2</sup> (AWG)			
	Size	Number	Specification	Standard Length
ASD-B2-0121-F	0.13 (AWG26)	10 core (4 pairs)	UL2464	3 m (9.84 ft.)
ASD-B2-0221-F				
ASD-B2-0421-F				
ASD-B2-0721-F				
ASD-B2-1021-F				
ASD-B2-1521-F				
ASD-B2-2023-F				
ASD-B2-3023-F				

Note:

1. Please use shielded twisted-pair cable for encoder wiring so as to reduce the interference of the noise.
2. The shield should connect to the  $\ominus$  phase of SHIELD.
3. Please follow the Selection of Wire Rod when wiring in order to avoid the danger it may occur.
4. Box, (□) at the end of the servo drive model represents the model code of ASDA B2-F. Please refer to the model information of the product you purchased.
5. Box, (□) in servo motor model represents brake or keyway / oil seal.
6. Triangle, (△) in servo motor model represents encoder type. Please refer to Chapter 1 for detail.

### 3.2 Basic Wiring

#### 3.2.1 200 W or models below (without regenerative resistor nor fan)

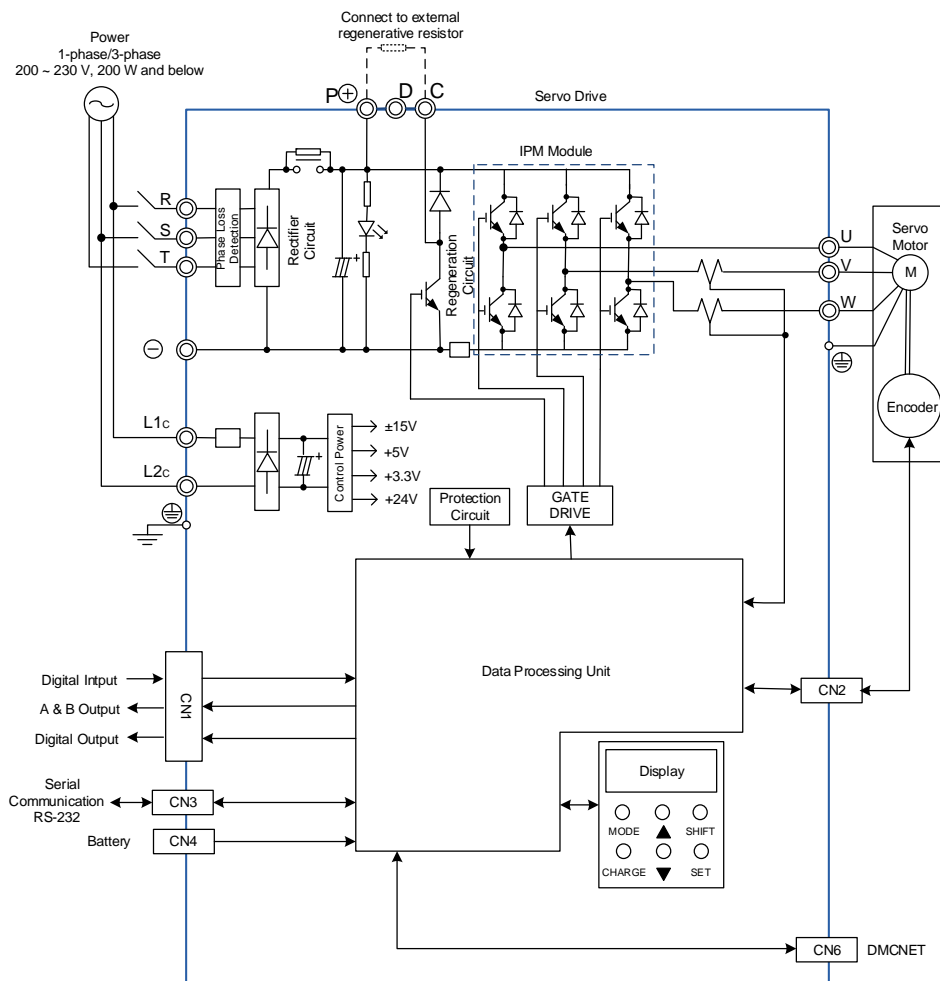

3

### 3.2.2 400 W ~ 750 W models (with built-in regenerative resistor but no fan)

3

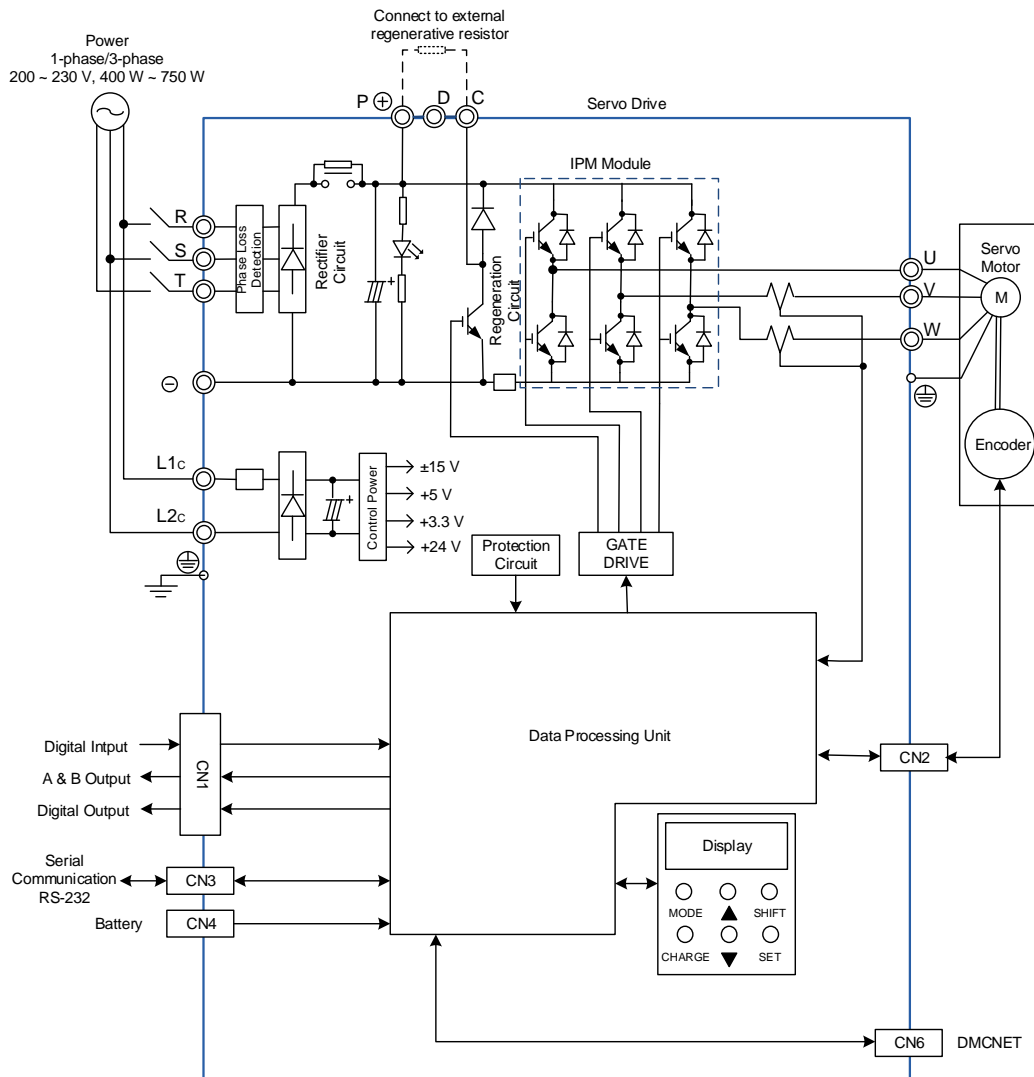

### 3.2.3 1 kW ~ 1.5 kW models (with built-in regenerative resistor and fan)

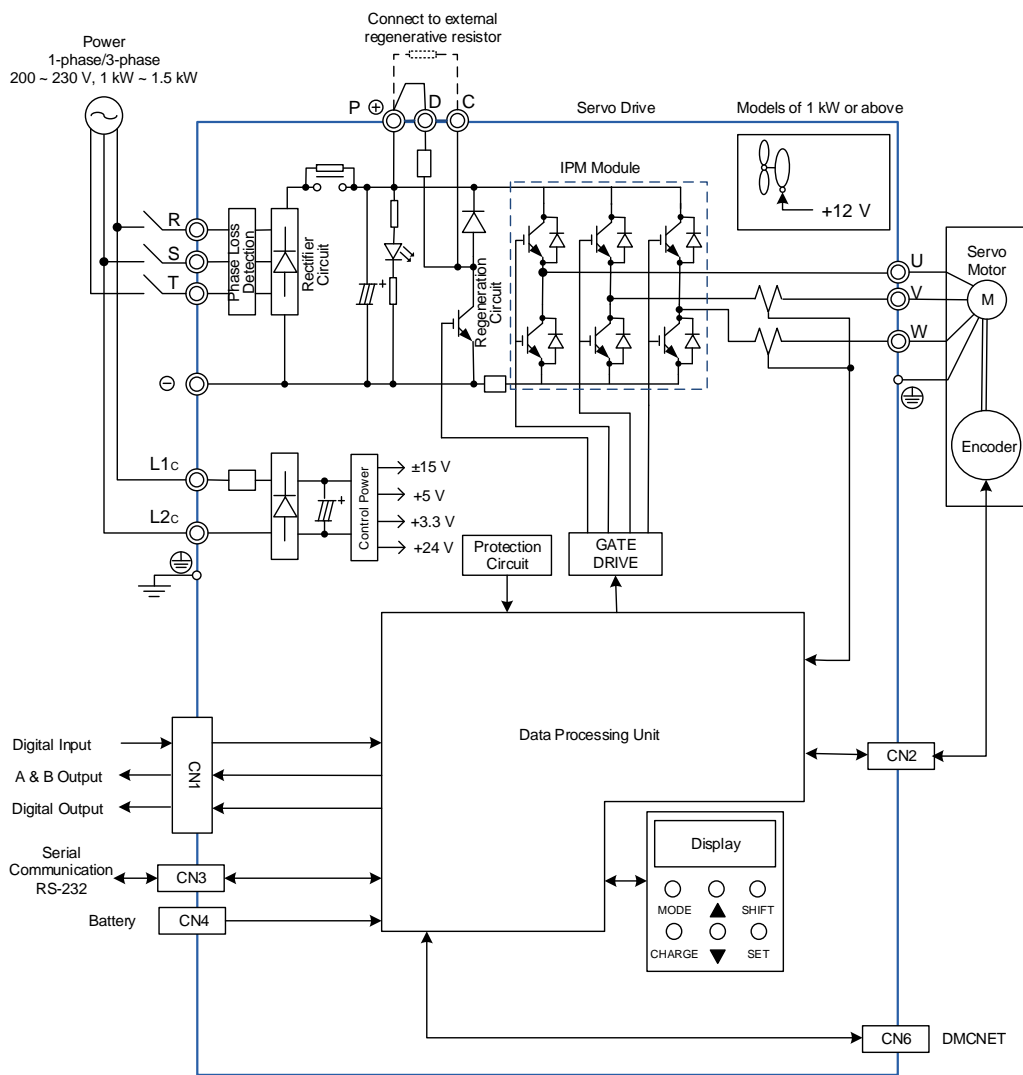

3

### 3.2.4 2 kW ~ 3 kW models (with built-in regenerative resistor and fan)

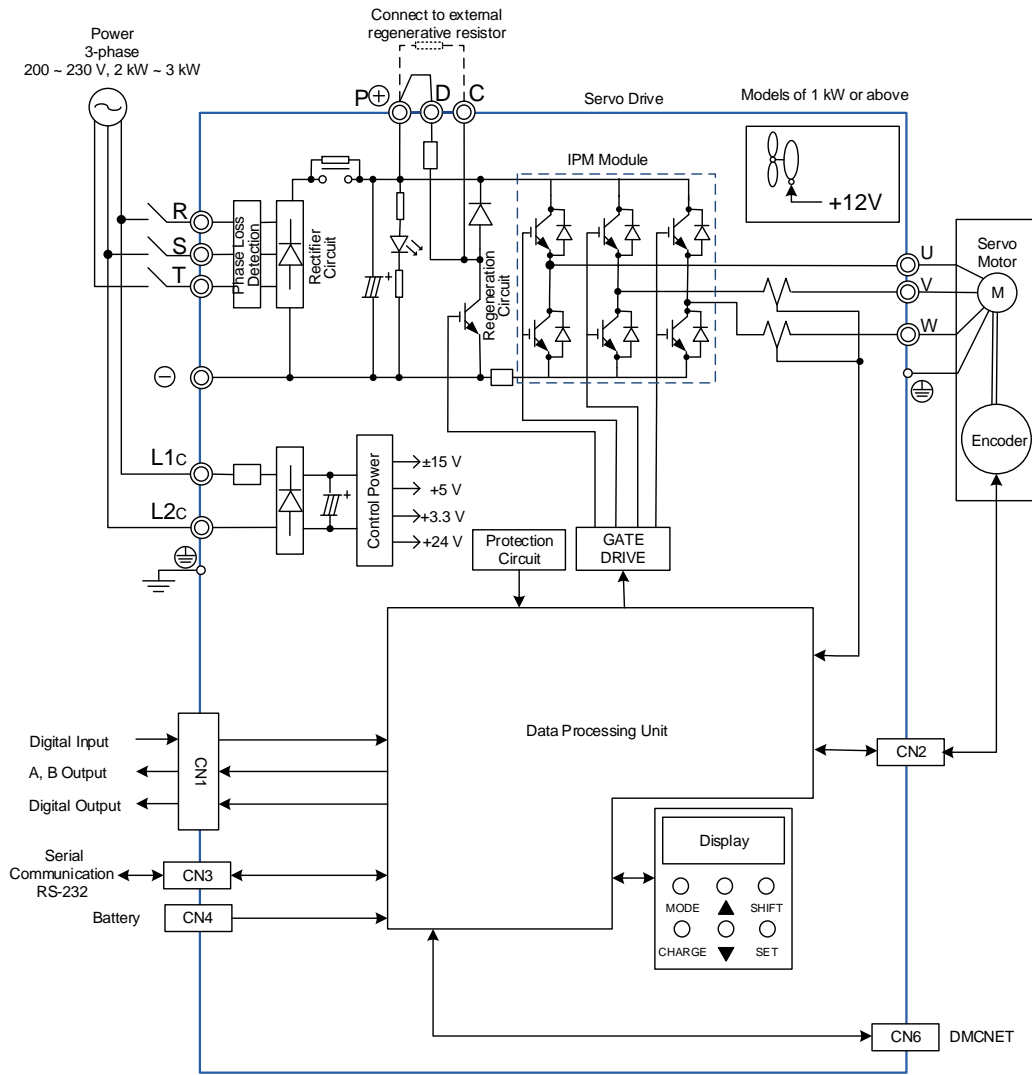

3

### 3.3 I / O Signal (CN1) Connection

#### 3.3.1 I / O Signal (CN1) Connector Terminal Layout

In order to have a more flexible communication with the master (the host controller), 2 programmable Digital Outputs (DO) and 5 programmable digital inputs (DI) are provided. The setting of 5 digital inputs and 2 digital outputs of each axis are parameter P2-10 ~ P2-14 and parameter P2-18 ~ P2-19 respectively. In addition, the differential output encoder signal, A+, A-, B+, and B- are also provided. The followings are the pin diagrams.



CN1 Connector (female)



Connector (male)

Front View      Rear View

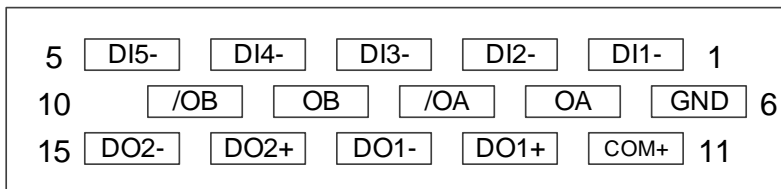

Pin No	Name	Function	Pin No	Name	Function	Pin No	Name	Function
1	DI1-	Digital input	6	GND	Control Panel Power 0 V	11	COM+	Power ground (12 ~ 24 V)
2	DI2-	Digital input	7	OA	Encoder A pulse output	12	DO1+	Digital output
3	DI3-	Digital input	8	/OA	Encoder /A pulse output	13	DO1-	Digital output
4	DI4-	Digital input	9	OB	Encoder B pulse output	14	DO2+	Digital output
5	DI5-	Digital input	10	/OB	Encoder /B pulse output	15	DO2-	Digital output

### 3.3.2 Signals Explanation of Connector CN1

The following details the signals listed in previous section:

#### General Signals

Signal		Pin No	Function	Wiring Method (Refer to 3.3.3)
Position Pulse (Output)	OA	7	Encoder signal output A and B (Line Drive output)	C5/C6
	/OA	8		
	OB	9		
	/OB	10		

Signal		Pin No	Function	Wiring Method (Refer to 3.3.3)
Power	COM+	11	The positive end of the external power (+12 V ~ +24 V) must be connected to COM+. COM+ is the common input of digital input.	-
	GND	6	Power of Control Panel 0 V	

There are various operation modes available in this servo drive (please refer to Chapter 6.1) and each mode requires different I/O signal configuration. Thus, programmable I/O signals are provided. That is, users are able to choose DI and DO signals to meet different application requirements. Basically, default setting of DI/DO signal has already have the appropriate function which can satisfy the demand of general application.

Refer to the following DI/DO table to know the corresponding default setting of DI/DO signal and Pin No of the selected mode in order to conduct the wiring.

#### The explanation of DO signal default setting is as follows.

Do Signal Name	Operation Mode	Pin No		Function	Wiring Method (Refer to 3.3.3)
		+	-		
SRDY	ALL	-	-	When the servo drive applies to the power and no alarm (ALRM) occurs in control circuit and motor power circuit, this DO is ON.	C1,C2
ZSPD	ALL	-	-	When the motor speed is slower than the setting value of parameter P1-38, this DO is ON.	

#### Note:

1. For example, if Sz mode is selected, pin 3 and 2 are defined as DO.TSPD.
2. The unlisted Pin No means the signal is not the preset one. If users want to use it, parameters need to be changed and set as the desired ones. Please refer to Section 3.3.4 for further detail.

The explanation of DI signal default setting is as the following.

DI Signal Name	Operation Mode	Pin No	Function	Wiring Method (Refer to 3.3.3)
ARST	ALL	-	When the alarm (ALRM) occurs, this signal is used to reset the servo drive and enable DI.SRDY again.	C3,C4
EMGS	ALL	5	It is contact <b>B</b> and always has to be ON; otherwise the alarm (ALRM) will occur.	
NL (CWL)	ALL	3	Reverse inhibit limit (contact <b>B</b> ) and always has to be ON; or the alarm (ALRM) will occur.	
PL (CCWL)	ALL	4	Forward inhibit limit (contact <b>B</b> ) and always has to be ON; or the alarm (ALRM) will occur.	

The default setting of DI and DO in each operation mode is shown as the followings. The table below is presented in a different way and the corresponding operation mode is put in the table in order to avoid confusion.

**Table 3.1 Default Value of DI Input Function**

Symbol	DI code	Input Function	DMC	Sz	Tz
ARST	0x02	Alarm reset	DI5	DI5	DI5
EMGS	0x21	Emergency stop	DI5	DI5	DI5
NL(CWL)	0x22	Reverse inhibit limit	DI3	DI3	DI3
PL(CCWL)	0x23	Forward inhibit limit	DI4	DI4	DI4

Note:

Please refer to Section 3.3.1 for corresponding pin from DI 1 ~ 5.

**Table 3.2 Default Value of DO Input Function**

Symbol	DO code	Input Function	DMC	Sz	Tz
SRDY	0x01	Servo ready	DO1	DO1	DO1
ZSPD	0x03	Zero-speed reached	DO2	DO2	DO2

Note:

Please refer to Section 3.3.1 for corresponding pin from DO1 ~ 2.

### 3.3.3 Wiring Diagrams (CN1)

When the drive connects to inductive load, the diode has to be installed. (The permissible current is under 40 mA. The surge current is under 100 mA.)

3

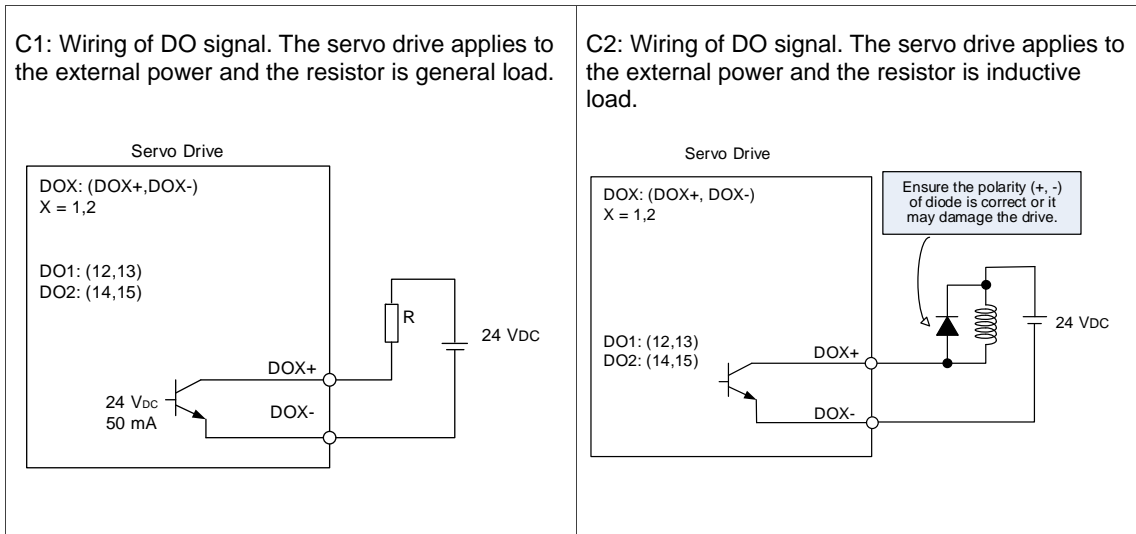

Input signal via relay or open-collector transistor  
**NPN** transistor, common emitter (E) mode (**SINK** mode)

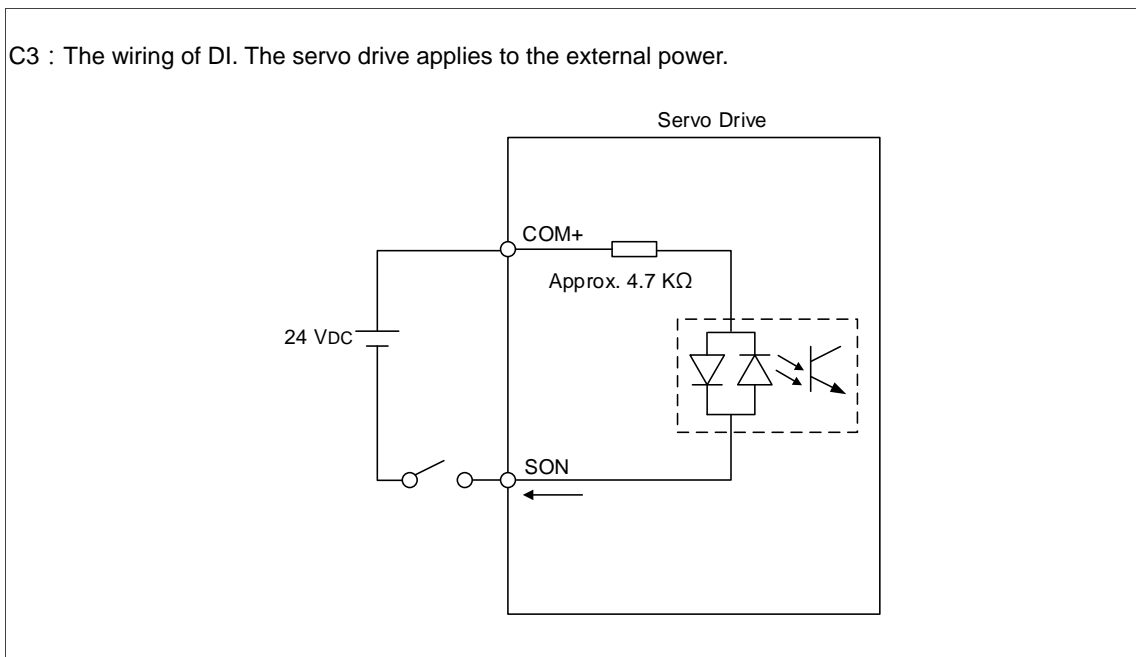

PNP transistor, common emitter (E) mode (**SOURCE** mode)

C4: The wiring of DI. The servo drive applies to the external power.

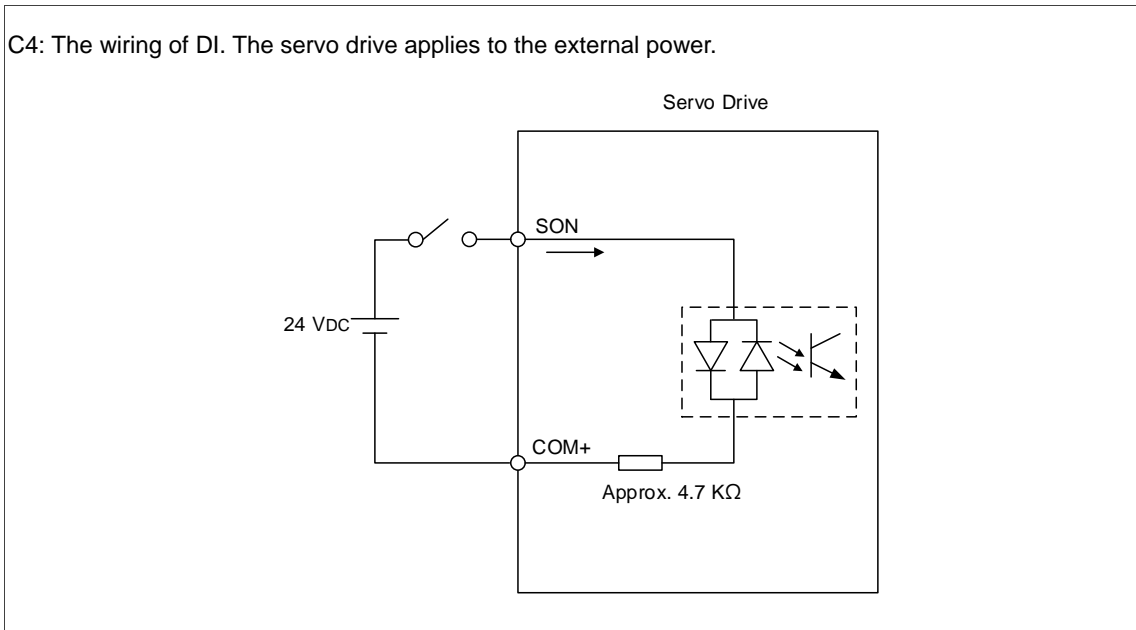

**Caution: Do not apply to dual power or it may damage the servo drive.**

C5: Encoder signal output (Line driver)

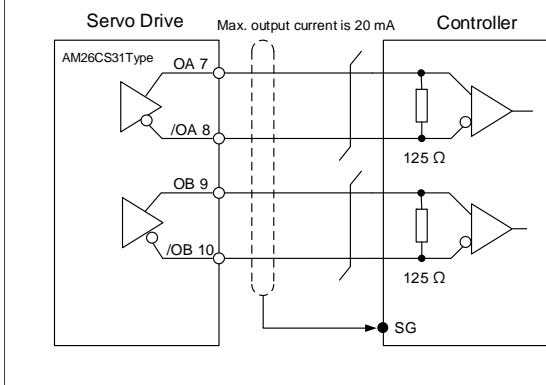

C6: Encoder signal output (Opto-isolator)

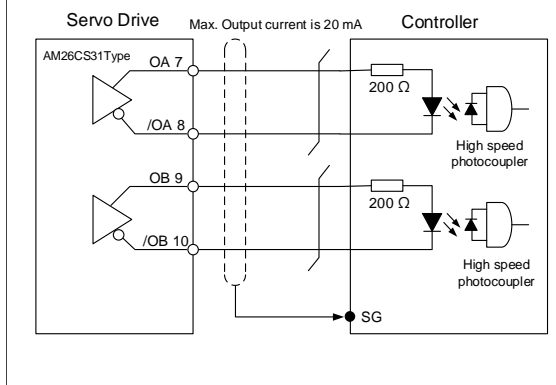

### 3.3.4 DI and DO Signal Specified by Users

If the default setting of DI/DO does not fulfill the requirement for the application, users can manually define the DI/DO signal. The signal function of DI 1 ~ 5, and DO1 ~ 2 is determined by parameter P2-10 ~ P2-14 and parameter P2-18 ~ P2-19 respectively. Please refer to the following table. Enter DI or DO code in the corresponding parameter to set up DI/DO.

Signal Name	Pin No	Corresponding Parameter
Standard DI	D11-	CN1-1
	D12-	CN1-2
	D13-	CN1-3
	D14-	CN1-4
	D15-	CN1-5

Signal Name	Pin No	Corresponding Parameter
Standard DO	DO1+	CN1-12
	DO1-	CN1-13
	DO2+	CN1-14
	DO2-	CN1-15
	-	-

### 3.4 CN2 Connector

CN2 encoder connector can be connected in two ways:

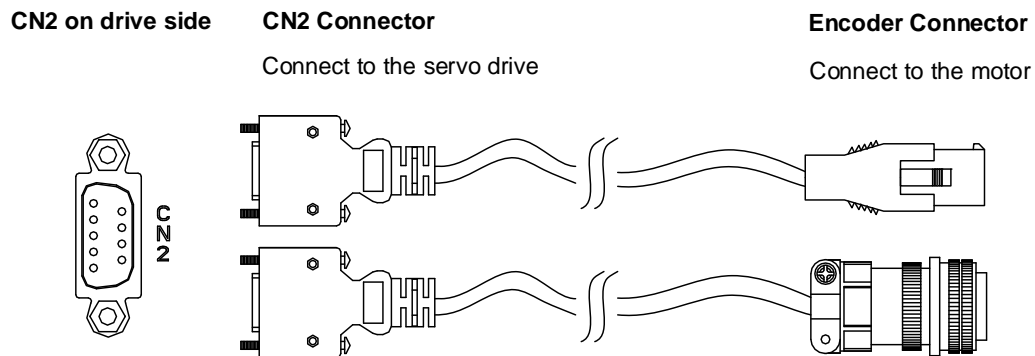

The terminal block of the connector and pin number are as follows:

(A) CN2 Connector

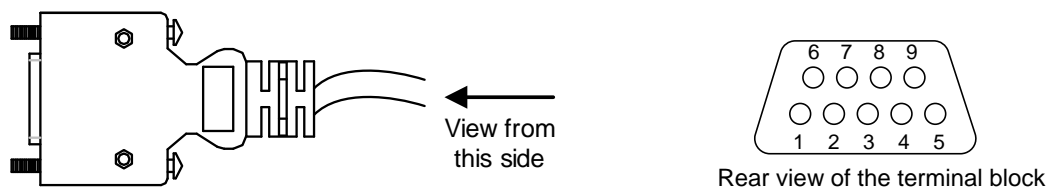

(B) Encoder Connector

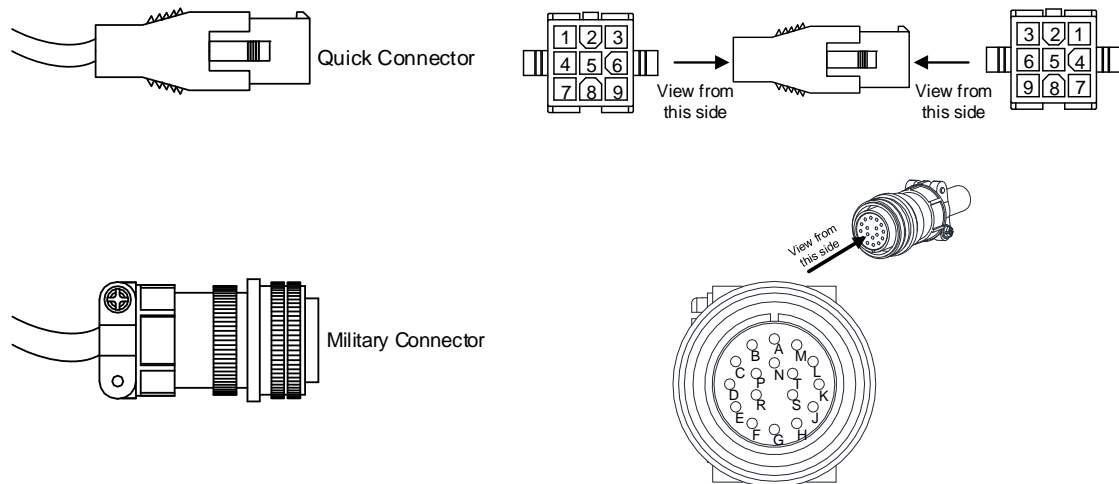

3

The definition of each signal is as follows:

Drive Connector			Encoder Connector		
Pin No	Terminal Symbol	Function and Description	Military Connector	Quick Connector	Color
4	T+	Serial communication signal input / output (+)	A	1	Blue
5	T-	Serial communication signal input / output (-)	B	4	Blue & Black
8	+5V	+5 V power supply	S	7	Red / Red & White
6, 7	GND	Power ground	R	8	Black / Black & White
Shell	Shielding	Shielding	L	9	-

The shielding procedures of CN2 encoder connector are as followings:



- (1) Weld the metal core wires with shielding outside with the metal part of the connector in order to have it fully shielded.



- (2) Install the connector with shielding into the plastic case as shown in the figure.



- (3) Tighten the screws to complete a shielded CN2 connector.

### 3.5 Wiring of CN3 Connector

#### Layout of CN3 Connector

The servo drive can be connected to the personal computer via communication connector. Users can operate the servo drive via MODBUS, PLC or HMI. The common communication interface, RS-232, is provided and its communication distance is about 15 meters.

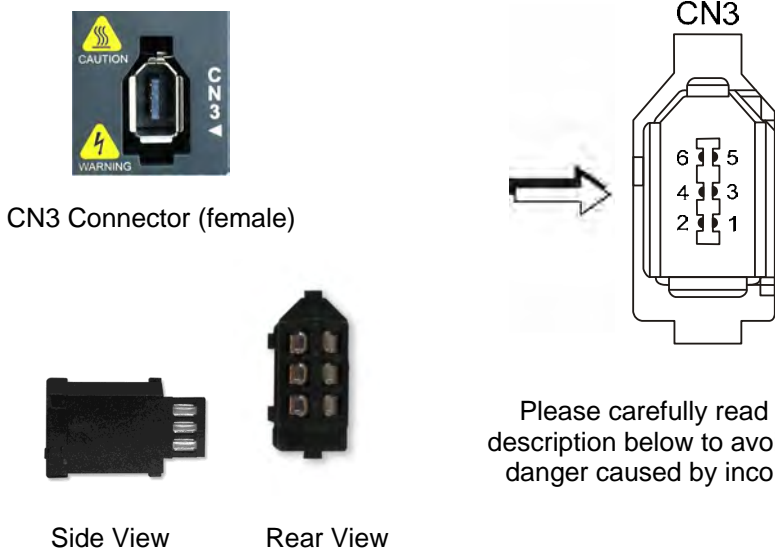

Pin No	Signal Name	Terminal Symbol	Function and Description
1	Grounding	GND	+ 5 V connects to the signal terminal
2	RS-232 data transmission	RS-232_TX	The drive transmits the data The connector connects to RS-232 of PC
3	-	-	Reserved
4	RS-232 data receiving	RS-232_RX	The drive receives the data The connector connects to RS-232 of PC
5	-	-	Reserved
6	-	-	Reserved

**Note:**  
Two kinds of communication wire of IEEE1394 are commercially available. One of the internal ground terminals (Pin 1) will short circuit with the shielding and will damage the drive. Do not connect GND to the shielding.

3

### 3.6 CN6 Connector (DMCNET)

CN6 uses the standard RJ45 connector, shielded communication cable, and connects to a host controller or motion card. DMCNET system is used to implement position, torque and speed mode. It also can read or monitor the drive status.

The station number of DMCNET is the same as RS-232. All are set via parameter P3-00 and the transmission rate is up to 20 Mbps. For connecting more than one drives, it provides two sets of communication connectors, one is for receiving and another is for transmission. The last servo drive connects to a 120-Ω termination resistor.

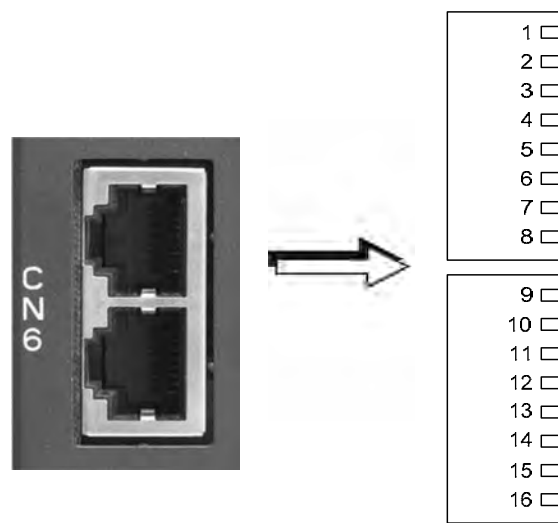

CN6 Connector (female)

Pin No	Signal Name	Function and Description
1, 9	DMCNET_1A	DMCNET Channel 1 bus line (+)
2, 10	DMCNET_1B	DMCNET Channel 1 bus line (-)
3, 11	DMCNET_2A	DMCNET Channel 2 bus line (+)
4, 12	-	Reserved
5, 13	-	Reserved
6, 14	DMCNET_2B	DMCNET Channel 2 bus line (-)
7, 15	-	Reserved
8, 16	Reserved	Reserved

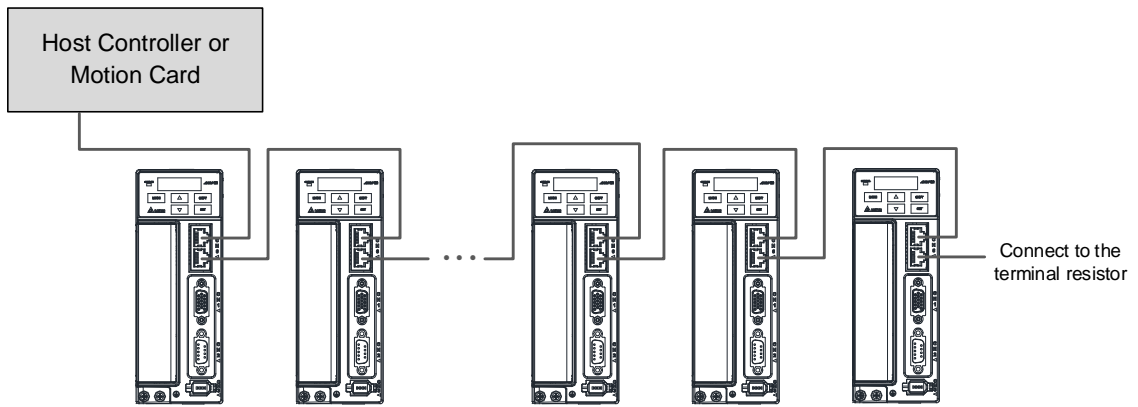

Max. axes: 12  
 Max. cable length: 30 m

Note:

1. The terminating resistor is suggested to use 120 Ω (Ohm) 0.25 W or above.
2. The wiring method of concatenate more than one drives is based on two terminals of DMCNET. One is for receiving and another one is for transmission. And the last servo drive connects to the termination resistor. The wiring diagram of the termination resistor is shown as the followings:

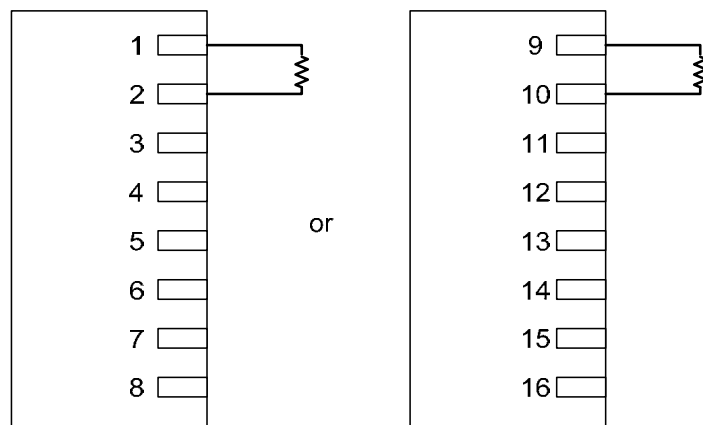

### 3.7 Standard Connection Example

#### Communication Mode

3

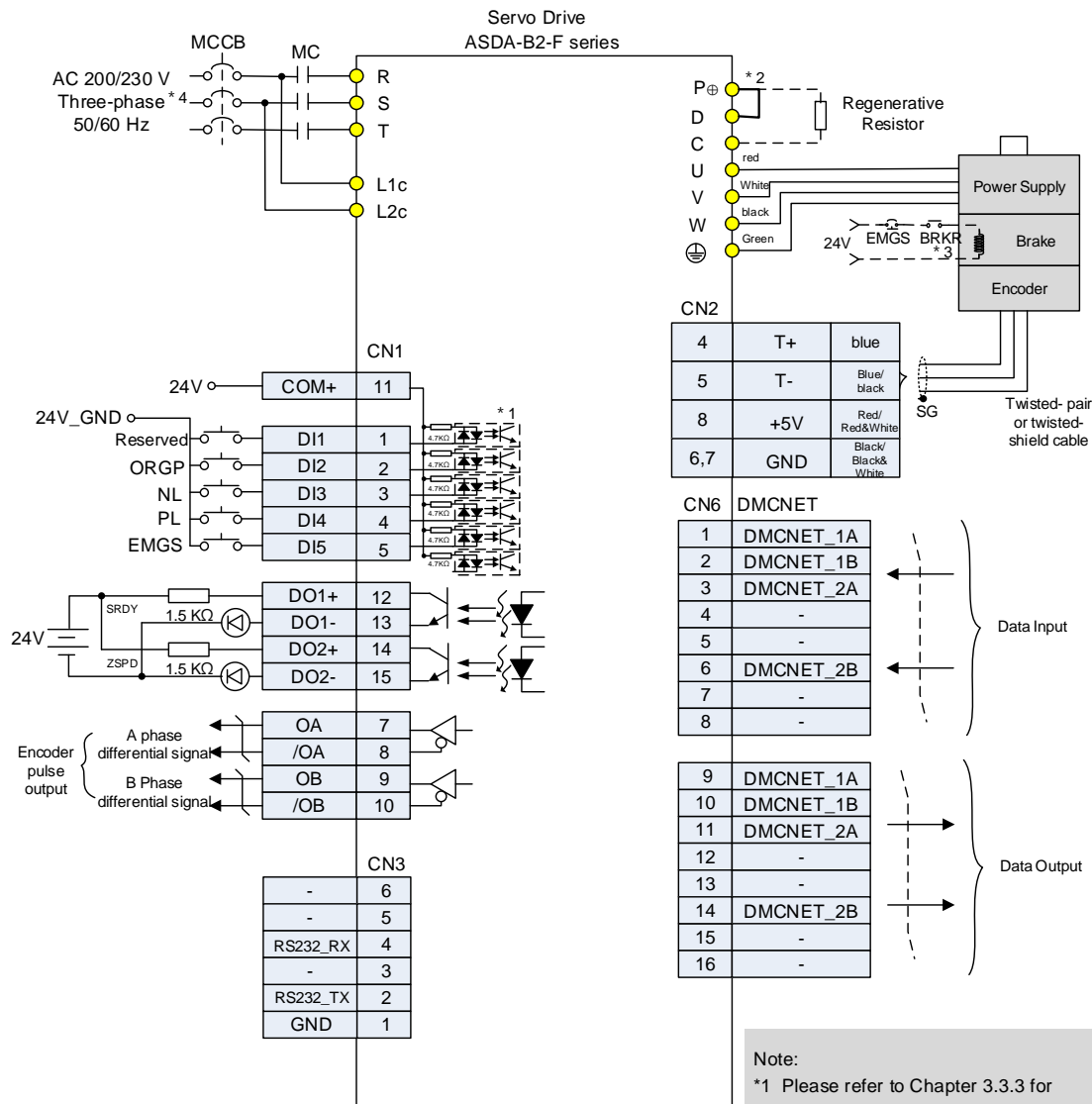

Note:

- \*1 Please refer to Chapter 3.3.3 for C3 ~ C6 wiring diagrams (SINK/SOURCE mode).
- \*2 Models below 200 W have no built-in braking resistor.
- \*3 The coil of brake has no polarity.
- \*4 Single-phase connections are for servo drives 1.5 kW and below only.

# Panel Display and Operation

# 4

# 4

This chapter explains the panel display of ASDA-B2-F and its operation. Users may check the operation status and see whether any alarm occurs via the panel.

4.1	Panel Description .....	4-2
4.2	Parameter Setting Procedure .....	4-3
4.3	Status Display .....	4-6
4.3.1	Save Setting Display .....	4-6
4.3.2	Decimal Point .....	4-6
4.3.3	Alarm Message .....	4-6
4.3.4	Positive and Negative Sign Setting .....	4-7
4.3.5	Monitor Display .....	4-7
4.4	General Function .....	4-10
4.4.1	Operation of Fault Record Display .....	4-10
4.4.2	JOG Mode .....	4-11
4.4.3	Force DO Output .....	4-12
4.4.4	Digital Input Diagnosis Operation .....	4-13
4.4.5	Digital Output Diagnosis Operation .....	4-14

# 4

## 4.1 Panel Description

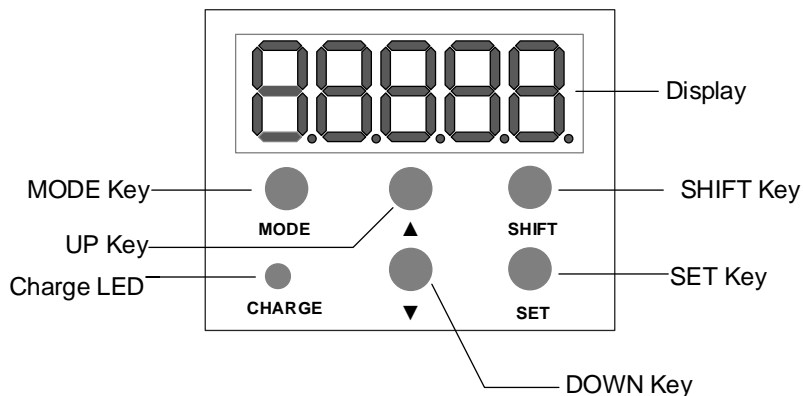

Name	Function
Display	Five-/Seven-segment display is for displaying the monitoring values, parameter values and setting values.
SHIFT Key	The group code can be changed in Parameter Mode. When in Editing Mode, moving the flashing bit to the left can adjust the higher setting bit. The display of high/low digit can be switched in Monitor Mode.
SET Key	Pressing the SET key can display and save the setting value. In monitor mode, pressing the SET key can switch decimal or hexadecimal display. In parameter mode, pressing the SET key can enter parameter setting mode.
DOWN Key	Pressing the DOWN key can scroll through and change monitoring codes, parameter groups and various parameter settings.
UP key	Pressing the UP key can scroll through and change monitoring codes, parameter groups and various parameter settings.
Charge LED	The Charge LED lights to indicate the power is applied to the circuit.
MODE Key	Pressing the MODE key can enter or exit different parameter groups, and switch between Monitor mode and Parameter mode.

## 4.2 Parameter Setting Procedure

Switching the mode:

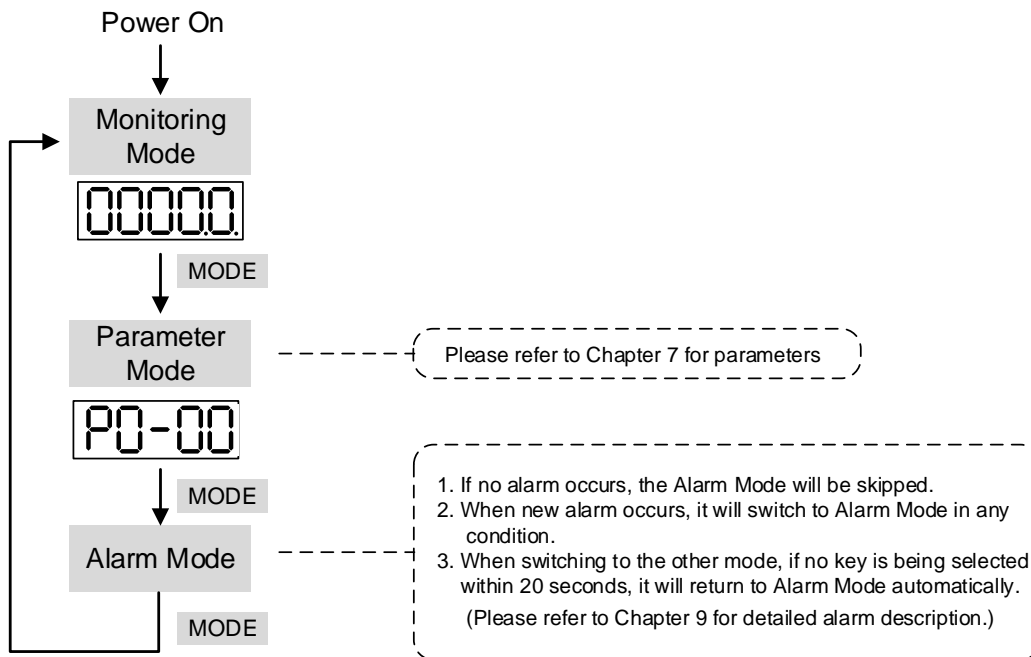

Operating in each mode:

Monitoring mode

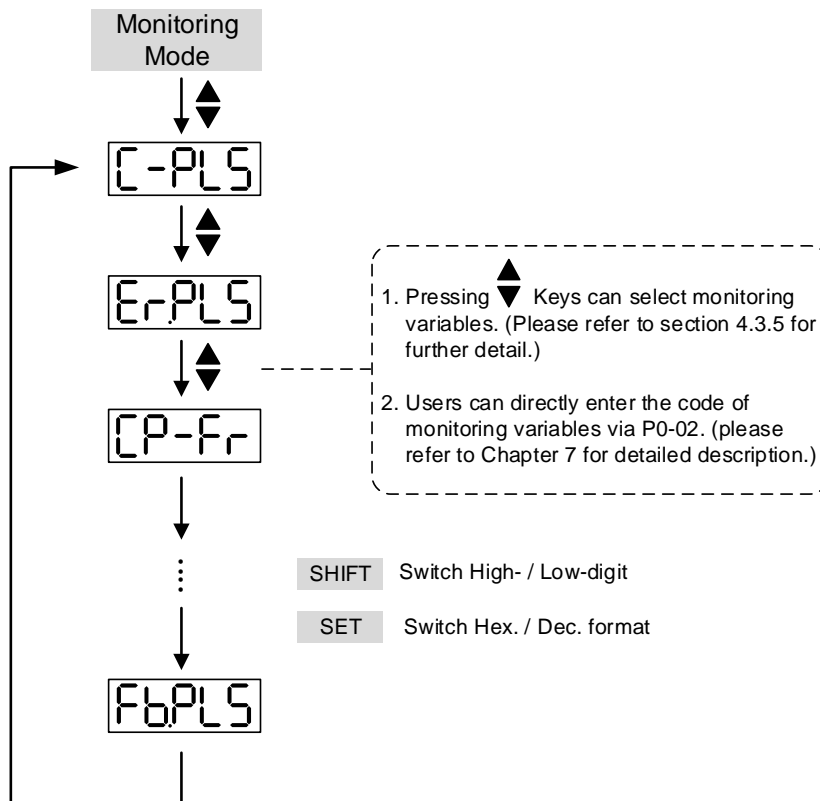

### Parameter Mode

4

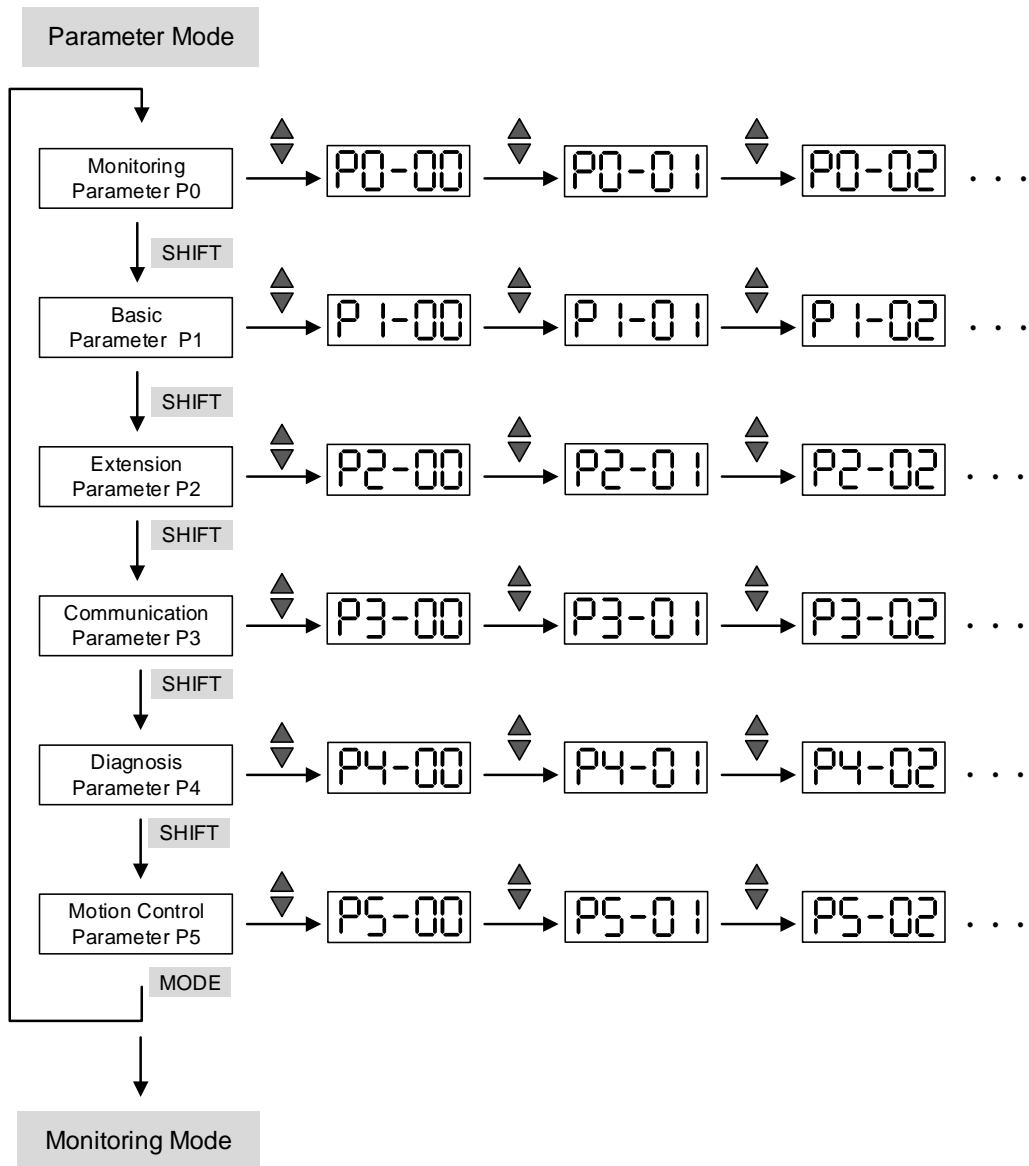

### Edit Setting Mode

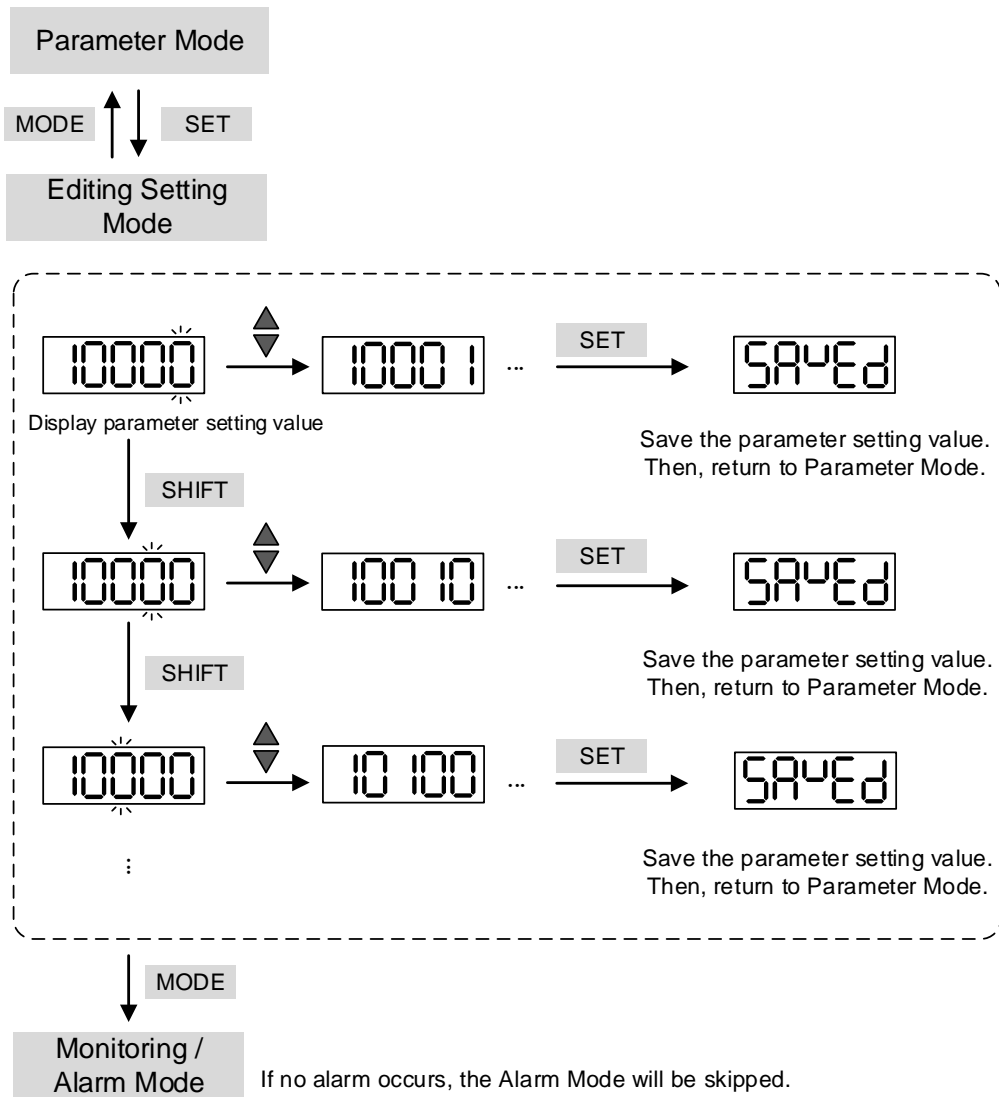



# 4

## 4.3 Status Display

### 4.3.1 Save Setting Display

When finishing editing parameter, press the SET Key to save the setting. The panel will display the setting status according to the setting for a second.

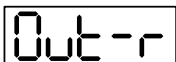
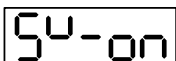
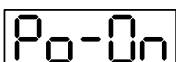
Displayed Symbol	Description
	The setting value is saved correctly. (Saved)
	Read-only parameter. Write-protected. (Read-Only)
	Enter the wrong password or no password has been entered. (Locked)
	Incorrect setting value or enter the reserved setting value. (Out of Range)
	No entering is allowed when it is Servo ON. (Servo On)
	Parameter will be effective after the servo drive is re-powered on. (Power On)

### 4.3.2 Decimal Point

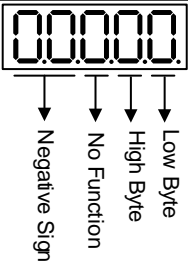
Displayed Symbol	Description
	<p>High byte / low byte indication: When the data is displayed in decimal 32 bits, it is for indicating the current high or low byte.</p> <p>Negative sign: When the data is displayed in decimal format, the two decimal points in the left represents the negative sign, no matter it is showed in 16 or 32 bits. When it is showed in hexadecimal format, it only shows positive sign.</p>

### 4.3.3 Alarm Message

Displayed Symbol	Description
	When alarm occurs, the servo drive will show 'AL' as the alarm sign and 'nnn' as the alarm code. For further explanation, please refer to Chapter 7, P0-01, parameter description, or Chapter 9, Troubleshooting.

### 4.3.4 Positive and Negative Sign Setting

Displayed Symbol	Description
	When entering the Editing Setting Mode, pressing the UP / DOWN Key can change the displayed value. The SHIFT Key can change the carry value users wish to alter. (The carry value is flashing at the moment.)
	Pressing the SHIFT Key for two seconds can switch the positive (+) and negative (-) sign. If the parameter value is over the range after switching the positive or negative sign, then it cannot be switched.





### 4.3.5 Monitor Display

When the drive is applied to the power, the display will show the monitor displayed symbol for a second, and then enter Monitoring Mode. In Monitoring Mode, the UP / DOWN Key can change the monitoring variable. Or, the user can directly change parameter setting of P0-02 to set the monitoring code. When applying to the power, the system will pre-set the monitoring code according to the setting value of P0-02. For example, the setting value of P0-02 is 4. Every time when applying to the power, it will display C-PLS monitor sign first, and then shows the input pulse number of pulse command.

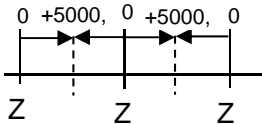
P0-02 Setting Value	Monitor Displayed Symbol	Description	Unit
0		Motor feedback pulse number (after the scaling of electronic gear ratio) (User unit)	[user unit]
1		Input pulse number of pulse command (after the scaling of electronic gear ratio) (User unit)	[user unit]
2		The difference of error pulse number between control command pulse and feedback pulse number (User unit)	[user unit]
3		Motor feedback pulse number (encoder unit) (1.28 million Pulse/rev)	[pulse]
4		Input pulse number of pulse command (before the scaling of electronic gear ratio) (encoder unit)	[pulse]
5		Error pulse number (after the scaling of electronic gear ratio) (encoder unit)	[pulse]
6		Input frequency of pulse command	[Kpps]
7		Motor speed	[r/min]
8		Speed input command	[Volt]
9		Speed input command	[r/min]
10		Torque input command	[Volt]
11		Torque input command	[%]
12		Average torque	[%]

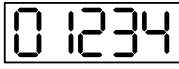
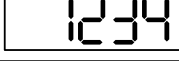
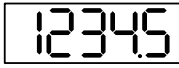
4

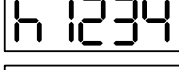
P0-02 Setting Value	Monitor Displayed Symbol	Description	Unit
13	PE-L	Peak torque	[%]
14	U bus	Main circuit voltage	[Volt]
15	J-L	Load / Motor inertia ratio (Note: If it shows 13.0, it means the actual inertia is 13)	[1 times]
16	IGbtt	IGBT temperature	[°C]
17	rSnfr	Resonance frequency (Low byte is the first resonance and high byte is the second one).	[Hz]
18	dIFF2 	The absolute pulse number of encoder Z phase equals the homing value, 0. It will be +5000 or -5000 pulse when rotating in forward or reverse direction.	-
19	nnAP1	Mapping parameter #1: shows the content of parameter P0-25 (specify the mapping target by P0-35)	-
20	nnAP2	Mapping parameter #2: shows the content of parameter P0-26 (specify the mapping target by P0-36)	-
21	nnAP3	Mapping parameter #3: shows the content of parameter P0-27 (specify the mapping target by P0-37)	-
22	nnAP4	Monitor variable #4: shows the content of parameter P0-28 (specify the monitor variable code by P0-38)	-
23	UAR-1	Monitor variable #1: shows the content of parameter P0-09 (specify the monitor variable code by P0-17)	-
24	UAR-2	Monitor variable #2: shows the content of parameter P0-10 (specify the monitor variable code by P0-18)	-
25	UAR-3	Monitor variable #3: shows the content of parameter P0-11 (specify the monitor variable code by P0-19)	-
26	UAR-4	Monitor variable #4: shows the content of parameter P0-12 (specify the monitor variable code by P0-20)	-

Example of the displayed value	Status Description	
 (Dec)	16 bits	If the value is 1234, it displays 01234 (shows in decimal format).
 (Hex)		If the value is 0x1234, it displays 1234 (shows in hexadecimal format; the first digit does not show any).
 (Dec high)	32 bits	If the value is 1234567890, the display of the high byte is 1234.5 and displays 67890 as the low byte (shows in decimal format).
 (Dec low)		
 (Hex high)		If the value is 0x12345678, the display of the high byte is h1234 and displays L5678 as the low byte (shows in hexadecimal format).
 (Hex low)		
 (Hex low)	Negative display. If the value is -12345, it displays 1.2.345 (only shows in decimal format; there is no positive or negative sign for hexadecimal format display).	

Note:

1. Dec means it is displayed in decimal format. Hex means it is displayed in hexadecimal format.
2. The above display methods can be applied in Monitoring Mode and Editing Setting Mode.
3. When all monitoring variables is 32 bits, high / low bit and the display (Dec/Hex) can be switched. According to the definition in Chapter 7, each parameter only supports one displaying method and cannot be switched.

# 4

## 4.4 General Function

### 4.4.1 Operation of Fault Record Display

When it is in Parameter Mode, select P4-00 ~ P4-04 and press the SET Key, the corresponding fault record will be shown.

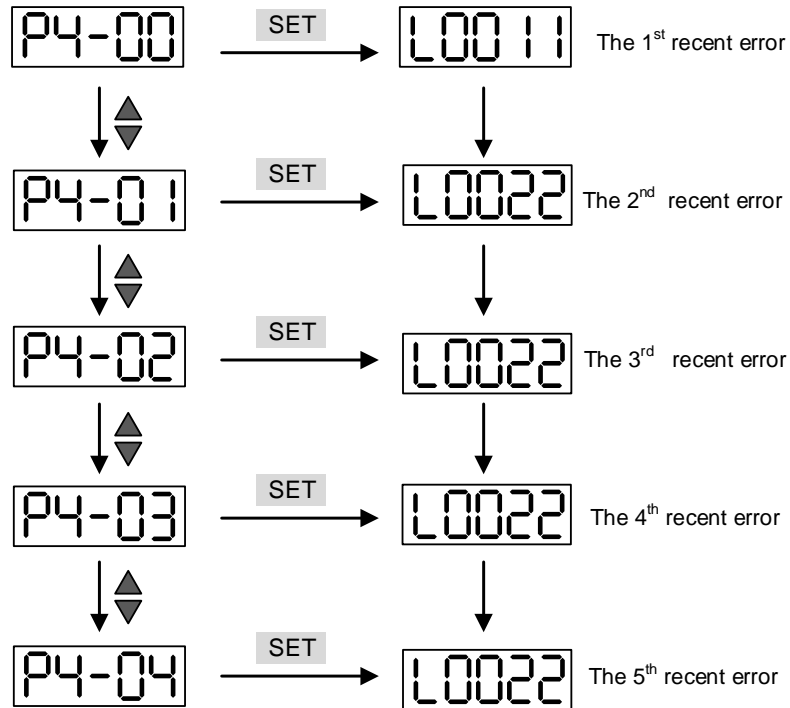

### 4.4.2 JOG Mode

When it is in Parameter Mode, select P4-05 and follow the setting method below for JOG operation.

1. Press the SET Key to display the speed of JOG. The default value is 20 r/min.
2. Press the UP or DOWN Key to adjust the desired speed of JOG. It is adjusted to 100 r/min in the example.
3. Press the SET Key to display JOG and enter JOG mode.
4. When it is in JOG Mode, press the UP or DOWN Key to enable the servo motor in forward or reverse direction. The servo motor stops running as soon as the user stops pressing the key. JOG operation is working only when it is Servo ON.

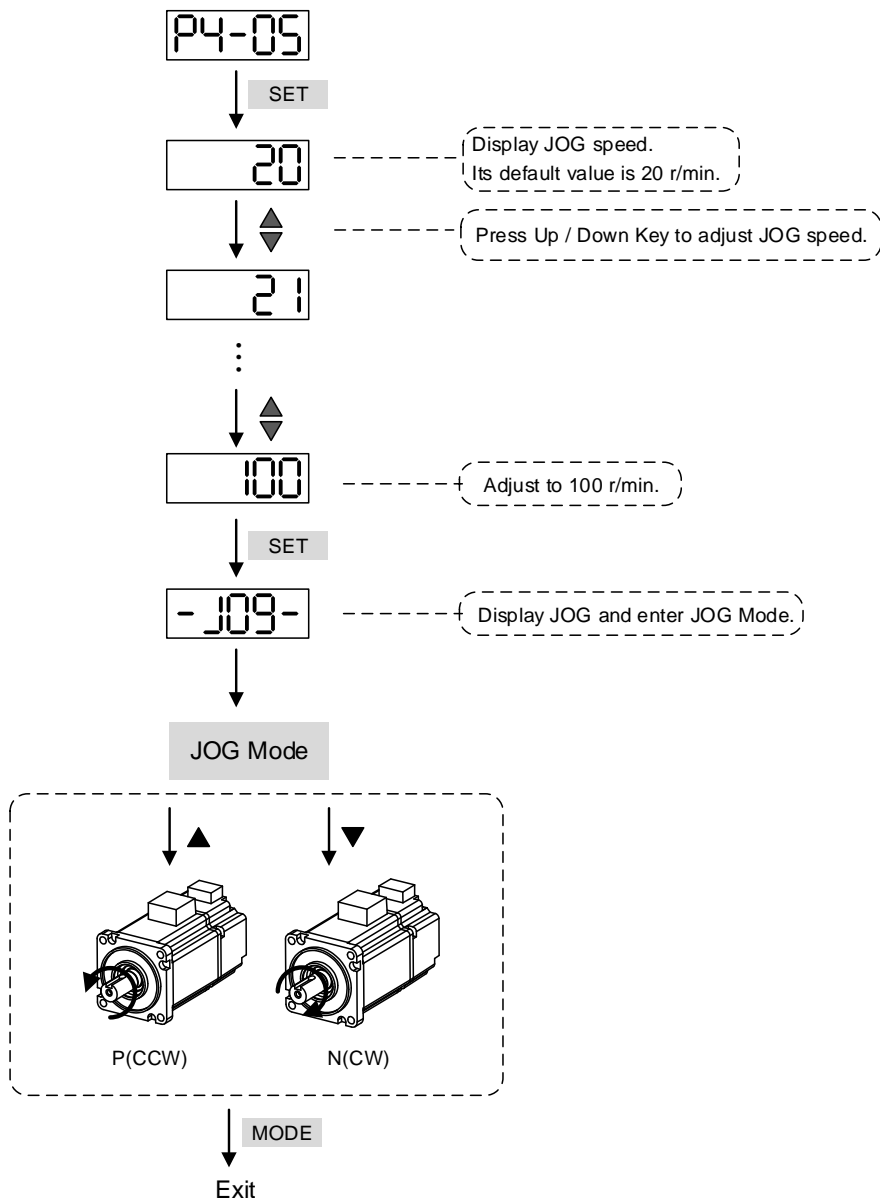

4

**4.4.3 Force DO On**

Enter the Diagnosis Mode by the following settings. Set P2-08 to 406 and enable the function of force DO on. Then, set the forced DO by binary method via P4-06. When the setting value is 2, it will force to enable DO2. When the setting value is 5, it will force to enable DO1 and DO3. No data is retained in this mode. It returns to the normal DO mode when re-power on the drive or set P2-08 to 400.

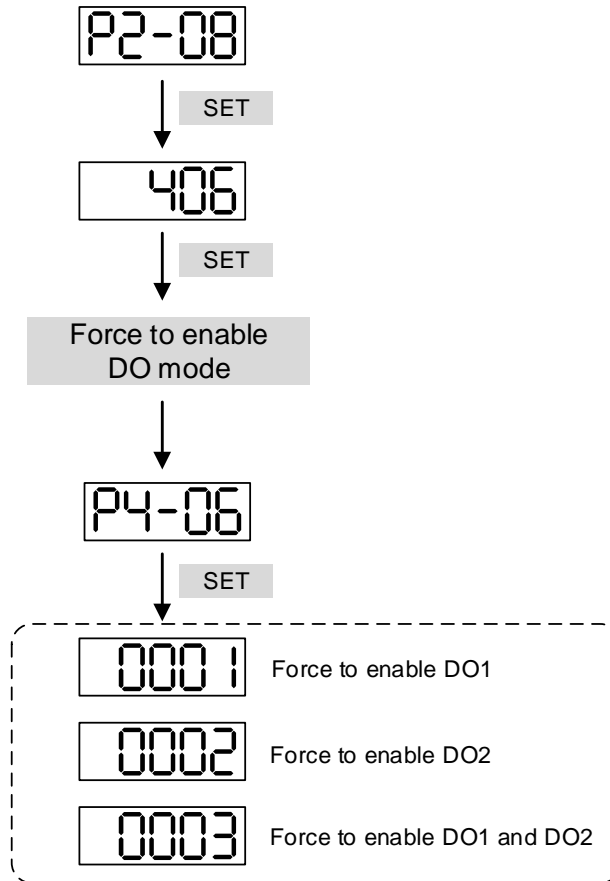

Note:  
P4-06 is displayed in hexadecimal format. Therefore, it will not show the fifth 0.

### 4.4.4 Digital Input Diagnosis Operation

Enter the Diagnosis Mode – DI by the following setting methods. When the external output signal DI1 ~ DI5 is ON, the corresponding signal will be shown on the panel. It is displayed by bit. When it shows bit, it means the DI is ON.

For example, if it shows **001E**, **E** is in hexadecimal format, it will be 1110 when it transfers to binary format. Then, DI2 ~ DI4 is ON.

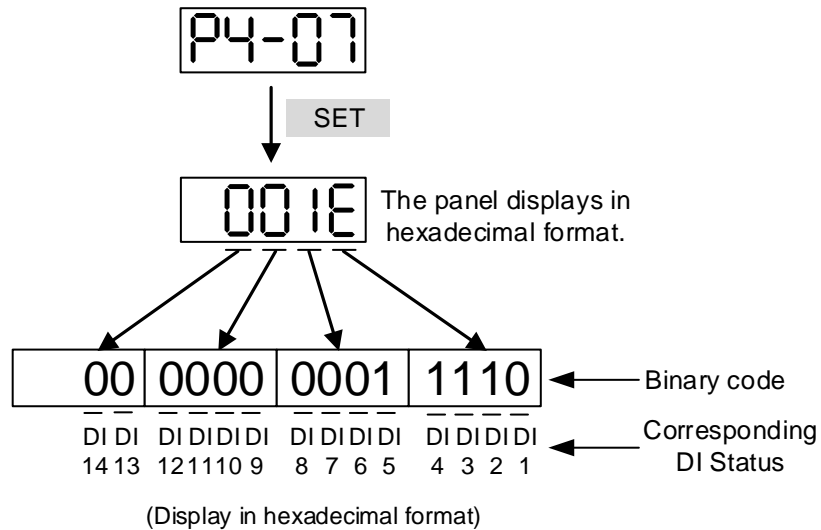

# 4

## 4.4.5 Digital Output Diagnosis Operation

Enter the Diagnosis Mode – DO by the following setting methods. The output signal DO1 ~ DO2 is ON and the corresponding signal will be shown on the panel. It is displayed by bit. When it shows 1, it means the DO is ON.

For example, if it shows **03**, 3 is in hexadecimal format, it will be **0011** when it transfers to binary format. Then, DO1~DO2 is ON.

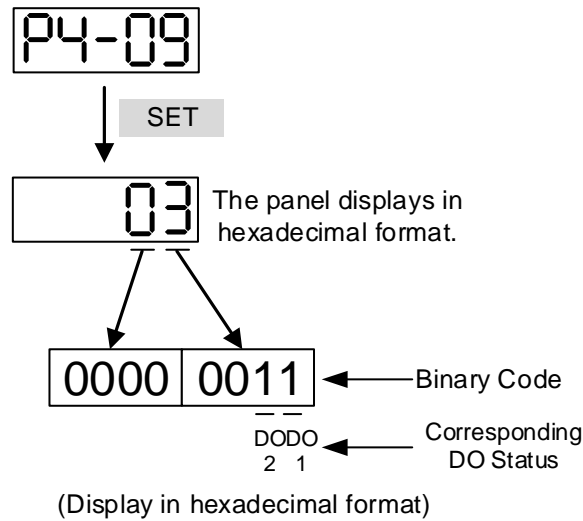

# Trial Operation and Tuning 5

---

This chapter illustrates how to do trial operation and the basic procedure of tuning. For your safety, please conduct the first inspection (without load) and then carry out further trial with load.

5.1	Inspection without Load .....	5-2
5.2	Apply Power to the Servo Drive .....	5-3
5.3	JOG Trial Run without Load .....	5-7
5.4	Trial Run without Load (Speed Mode) .....	5-8
5.5	Tuning Procedure .....	5-10
5.5.1	Flowchart of Tuning Procedure .....	5-11
5.5.2	Inertia Estimation Flowchart (with Mechanism) .....	5-12
5.5.3	Flowchart of Auto Tuning .....	5-13
5.5.4	Flowchart of Semi-Auto Tuning .....	5-14
5.5.5	Limit of Inertia Ratio .....	5-15
5.5.6	Mechanical Resonance Suppression Method .....	5-17
5.5.7	Tuning Mode and Parameters .....	5-18
5.5.8	Tuning in Manual Mode .....	5-19

## 5

## 5.1 Inspection without Load

Please remove the load from the servo motor, including coupling on the shaft and accessories so as to avoid any damage to servo drive or mechanism. This is for avoiding the falling off of the disassembled parts of the motor shaft and indirectly causing the personnel injury or equipment damage during operation. Running the motor without load, if the servo motor can run during normal operation, then it can operate with load.

**Caution: To avoid danger, please operate the servo motor without load first and ensure it runs normally. Then, operate the motor with load.**

Please carefully check the following items before operation to avoid any damage to the motor.

### Inspection before operation (not applied to the power )

- Check if there is any obvious damage shown on its appearance.
- The splicing parts of the wiring terminal should be isolated.
- Make sure the wiring is correct so as to avoid the damage or any abnormality.
- Make sure electric conductivity objects including sheetmetal (such as screws) or inflammable objects are not in the servo drive.
- Make sure the control switch is OFF.
- Do not place the servo drive or external regenerative resistor on inflammable objects.
- To avoid the electromagnetic brake losing efficacy, please check if stop function and circuit break function can work normally.
- If the peripheral devices are interfered by the electronic instruments, please reduce electromagnetic interference with devices.
- Please make sure the external voltage level of the servo drive is correct.

### Inspection when running the servo drive (already applied to the power)

- The encoder cable should avoid excessive stress. When the motor is running, make sure the cable is not frayed or over extended.
- Please contact with Delta if there is any vibration of the servo motor or unusual noise during the operation.
- Make sure the setting of the parameters is correct. Different machinery has different characteristic, please adjust the parameter according to the characteristic of each machinery.
- Please reset the parameter when the servo drive is in Servo Off status, or it may cause malfunction.
- When the relay is operating, make sure it can work properly.
- Check if the power indicator and LED display works normally.

## 5.2 Apply Power to the Servo Drive

Please follow the instructions below.

- A. Make sure the wiring between the motor and servo drive is correct:
  - U, V, W and FG have to connect to cable red, white, black and green respectively. If the wiring is incorrect, the motor cannot work normally. The ground wire FG of the motor must be connected to the ground terminal of the servo drive. Please refer to Chapter 3.1 for wiring.
  - The encoder cable of the motor has correctly connected to CN2: If users only desire to carry out JOG function, connecting CN1 and CN3 is not needed (Please refer to Chapter 5.3). Refer to Chapter 3.1 and 3.4 for the wiring of CN2.

**Caution: Do not connect the power (R, S, T) to the output terminal (U, V, W) of the servo drive. Or it might damage the servo drive.**

B. Power circuit of the servo drive:

Apply power to the servo drive. Please refer to Chapter 3.1.3 for power wiring.

C. Power on:

Power of the servo drive: including control circuit (L1c, L2c) and main circuit (R, S, T) power.

When the power is on, the display of the servo drive will be:



The default of digital input (DI3 ~ DI5) are the signal of reverse inhibit limit (NL), forward inhibit limit (PL), and emergency stop (EMGS), if DI3 ~ DI5 is not used, adjusting the setting of P2-12 ~ P2-14 is a must, which can be set to 0 (disable this DI function) or modified to another function.

From the last setting, if the servo drive status displays parameter P0-02 setting as the motor speed (07), then the screen display will be:

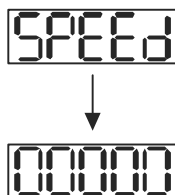

When the panel displays no text, please check if the power of control circuit is undervoltage.

# 5

(1) When the screen displays

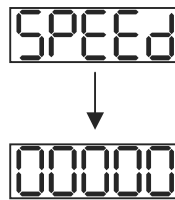

Warning of overvoltage:

It means the voltage input by the main circuit is higher than the rated range or a power input error has occurred (incorrect power system).

Corrective action:

- Use the voltmeter to measure if the input voltage from the main circuit is within the range of rated voltage.
- Use the voltmeter to measure if the power system complies with the specifications.

(2) When the screen displays



Warning of encoder error:

Check if the motor encoder is securely connected and the wiring is correct.

Corrective action:

- Make sure the wiring is the same as the instruction of the user manual.
- Check the encoder connector.
- Check if the wiring is loose.
- Check if the encoder is damaged. If yes, please change a new one.

(3) When screen displays

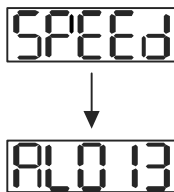

Warning of emergency stop:

Please check if any of the digital input DI1 ~ DI5 is set to emergency stop (EMGS).

Corrective action:

- If not desire to set emergency stop (EMGS) as one of the digital input, make sure no digital input is set to emergency stop (EMGS) among DI1 ~ DI5. (That is to say none of the parameters, P2-10 ~ P2-14 is set to 21.)
- If the function of emergency stop (EMGS) is needed and this DI is set as normally close (function code: 0x0021), please make sure this DI is always normally close. If not, please set this DI as normally open (function code: 0x0121).

(4) When screen displays

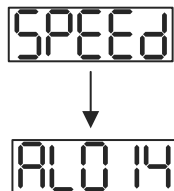

Warning of negative limit error:

Please check if any of the digital input DI1 ~ DI5 is set to negative limit (NL) and that DI is ON.

Corrective action:

- If not desire to set negative limit (NL) as one of the digital input, make sure no digital input is set to negative limit (NL) among DI1 ~ DI5. (That is to say none of the parameters, P2-10 ~ P2-14 is set to 22.)
- If the function of negative limit (NL) is needed and this DI is set as normally close (function code: 0x0022), please make sure this DI is always normally close. If not, please set this DI as normally open (function code: 0x0122).

(5) When screen displays



Warning of positive limit error :

Please check if any of the digital input DI1 ~ DI5 is set to positive limit (PL) and that DI is ON.

Corrective action:

- If not desire to set positive limit (PL) as one of the digital input, make sure no digital input is set to positive limit (PL) among DI1 ~ DI5 (That is to say none of the parameters, P2-10 ~ P2-14 is set to 23.)

## 5

- If the function of positive limit (PL) is needed and this DI is set as normally close (function code: 0x0023), please make sure this DI is always normally close. If not, please set this DI as normally open (function code: 0x0123).

(6) When screen displays

A digital display showing the code 'AL001' in a rectangular frame.

Warning of overcurrent:

Corrective action:

- Check the connection between the motor and servo drive.
- Check if the conducting wire is short circuited.

Exclude short circuit and avoid metal conductors being exposed.

(7) When screen displays

A digital display showing the code 'AL003' in a rectangular frame.

Warning of undervoltage:

Corrective action:

- Check if the wiring of main circuit input voltage is correct.
- Use voltmeter to measure if the main circuit voltage is normal.
- Use voltmeter to measure if the power system complies with the specification.

Note:

During power on or servo on (without issuing any command), if an alarm occurs or any abnormal display is shown, please contact the distributors.

### 5.3 JOG Trial Run without Load

It is very convenient to test the motor and servo drive with the method of JOG trial run without load since the extra wiring is unnecessary. For safety reasons, it is recommended to set JOG at low speed. Please see the following descriptions.

**Step 1:** Use software setting to Servo On the drive. Set parameter P2-30 to 1. This setting is to force servo on the drive through software.

**Step 2:** Set P4-05 to JOG speed (Unit: r/min). After setting the desired JOG speed, press the **SET** key, the servo drive will enter JOG mode.

**Step 3:** Press the **MODE** key to exist JOG mode.

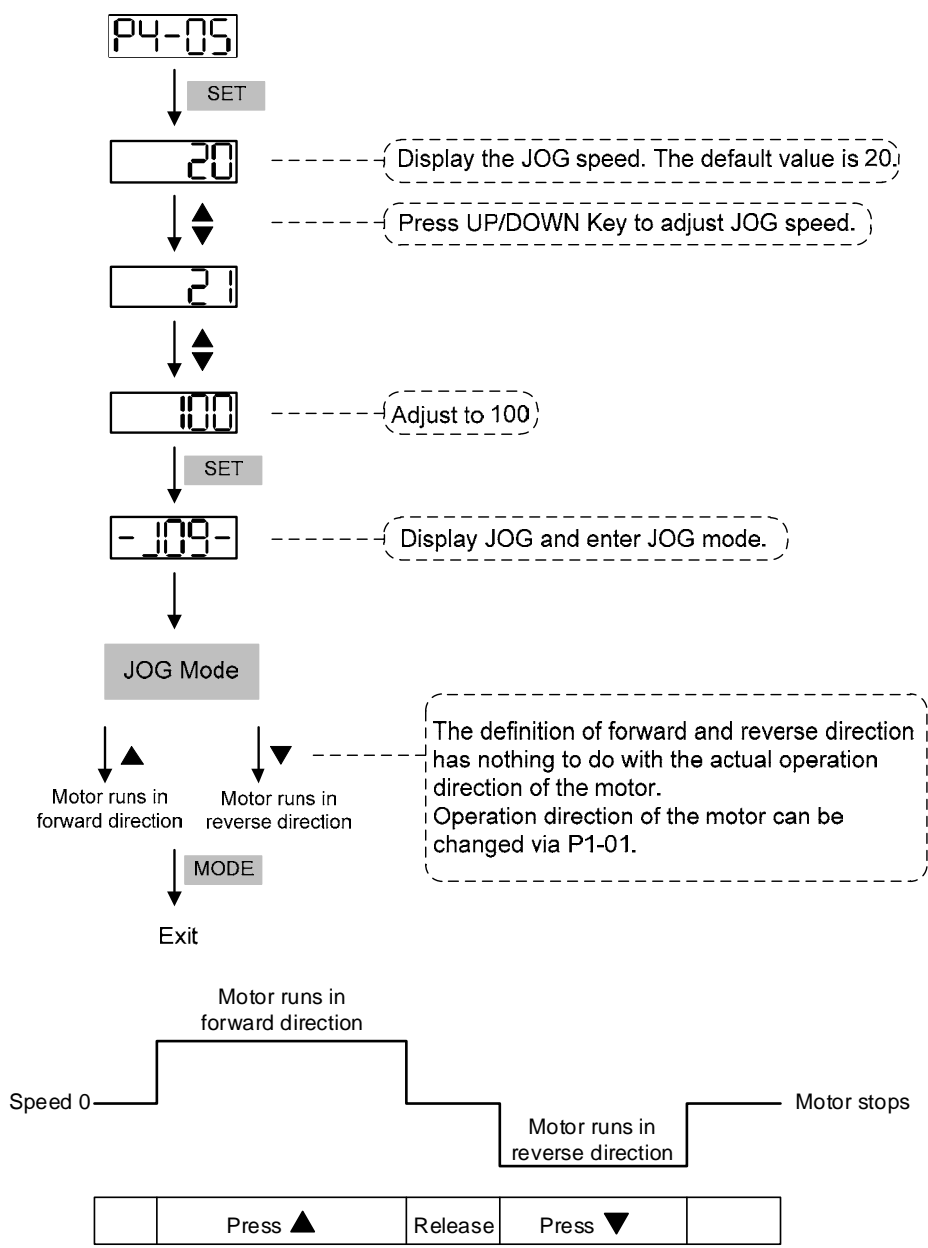

If the motor does not run, please check if the wiring between UVW and encoder cable is correct.  
 If the motor runs abnormally, please check if the UVW phase sequence is correct.

5

### 5.4 Trial Run without Load (Speed Mode)

Before starting trial run without load, firmly secure the motor base so as to avoid the danger caused by the reacting force generated during speed change.

**Step 1:** Set the control mode of the servo drive to speed mode. Set P1-01 to 2 as speed mode. Then, re-power on the servo drive.

**Step 2:** In speed mode, the digital input settings of trial run are as follows:

Digital Input	Parameter Setting Value	Symbol	Function Description	CN1 Pin No
DI1	P2-10 = 101	SON	Servo ON	DI1- = 1
DI2	P2-11 = 104	CCLR	Pulse Clear	DI2- = 2
DI3	P2-12 = 114	SPD0	Speed Selection	DI3- = 3
DI4	P2-13 = 115	SPD1	Speed Selection	DI4- = 4
DI5	P2-14 = 0	Disabled	DI disabled	DI5- = 5

The above table shows the settings that disable the function of negative limit (DI3), positive limit (DI4) and emergency stop (DI5). Thus, parameter P2-14 is set to 0 (Disabled); DI3 and DI4 are set to Speed Selection (SPD0) and Speed Selection (SPD1) respectively. The digital input of Delta’s servo drive can be programmed by users. When programming digital input, please refer to the description of DI code.

The default setting includes the function of negative limit, positive limit and emergency stop; therefore, if any alarm occurs after setting completed, please re-power on the servo drive or set DI.ARST to On to clear the alarm. Please refer to Chapter 5.2.

The speed command selection is determined by SPD0 and SPD1. See the table below.

Speed Command No.	DI signal of CN1		Command Source	Content	Range
	SPD1	SPD0			
S1	0	0	N/A	Speed command is zero	0
S2	0	1	Register parameter	P1-09	-60000 ~ 60000
S3	1	0		P1-10	-60000 ~ 60000
S4	1	1		P1-11	-60000 ~ 60000

0 means DI is Off; 1 means DI is On

Register parameter

The parameter setting range is from -60000 to 60000. Setting speed = Setting range x unit (0.1 r/min).

For example: P1-09 = +30000; Setting speed = +30000 x 0.1 r/min = +3000 r/min

Command setting of speed register

Set parameter P1-09 to 30000

Set parameter P1-10 to 1000

Set parameter P1-11 to -30000.

Input command	Rotation direction
+	CCW
-	CW

**Step 3:**

- (1) Switch ON DI 1 and Servo On.
- (2) Both DI 3 (SPD0) and DI 4 (SPD1), the speed command, are OFF, which means it currently executes S1 command. The motor rotates according to analog voltage command.
- (3) When DI3 (SPD0) is ON, it means it currently executes S2 command (3000 r/min). The rotation speed is 3000 r/min for rotary motor.
- (4) When DI4 (SPD1) is ON, it means it currently executes S3 command (100 r/min). The rotation speed is 100 r/min.
- (5) When both DI3(SP0) and DI4(SP1) are ON, it means S4 command (-3000 r/min) is executed at the moment. The rotation speed is -3000 r/min.
- (6) Step (3), (4) and (5) can be repeatedly executed.
- (7) If users desire to stop the motor, switch off DI1 (Servo Off).

5

### 5.5 Tuning Procedure

Estimate the inertia ratio: JOG Mode

1. After completing wiring, when applying to the power, the servo drive will display:	<b>AL013</b>
2. Press the <b>MODE</b> key to select the mode of parameter function.	<b>P0-00</b>
3. Press the <b>SHIFT</b> key to select the mode of parameter group.	<b>P2-00</b>
4. Press the <b>UP</b> key to select parameter P2-17.	<b>P2-14</b>
5. Press the <b>SET</b> key to display parameter value, which is shown as the content on the right.	<b>21</b>
6. Press the <b>SHIFT</b> key twice, then press the <b>UP</b> key and then press the <b>SET</b> key.	<b>121</b>
7. Press the <b>UP</b> key to select parameter P2-30.	<b>P2-30</b>
8. Press the <b>SET</b> key to display the parameter value.	<b>0</b>
9. Press the <b>UP</b> key and select the parameter value 1.	<b>1</b>
10. Then, the servo drive is ON and will show:	<b>00000</b>
11. Press the <b>DOWN</b> key to select the estimated inertia ratio.	<b>J-L</b>
12. The panel displays the current value of inertia ratio (default value).	<b>1.0</b>
13. Press the <b>MODE</b> key to select the mode of parameter function.	<b>P2-30</b>
14. Press the <b>SHIFT</b> key to select the mode of parameter group.	<b>P4-00</b>
15. Press the <b>UP</b> key to select parameter P4-05.	<b>P4-05</b>
16. Press the <b>SET</b> key to show the content, which is 20 r/min at JOG speed. Press the <b>UP</b> and <b>DOWN</b> key to raise or reduce the JOG speed. Press the <b>SHIFT</b> key to move to the next digit of the left.	<b>20</b> ↓ <b>200</b>
17. Set the desired JOG speed and press the <b>SET</b> key. Then, the figure displays as shown on the right.	<b>-JOG-</b>
18. Press the <b>UP</b> key to rotate the motor in forward direction or press the <b>DOWN</b> key the motor will rotate in reverse direction.	
19. Carry out JOG operation at low speed first. With the constant speed, if the motor operates smoothly in forward and reverse direction, users can carry out JOG operation at higher speed.	
20. In P4-05, the servo drive cannot display inertia ratio. Please press the <b>MODE</b> key twice to view the value of inertia ratio. If users desire to start JOG operation again, press the <b>MODE</b> key, and then press the <b>SET</b> key twice. Observe the panel display to see if the load inertia ratio remains at the same value after acceleration and deceleration.	

### 5.5.1 Flowchart of Tuning Procedure

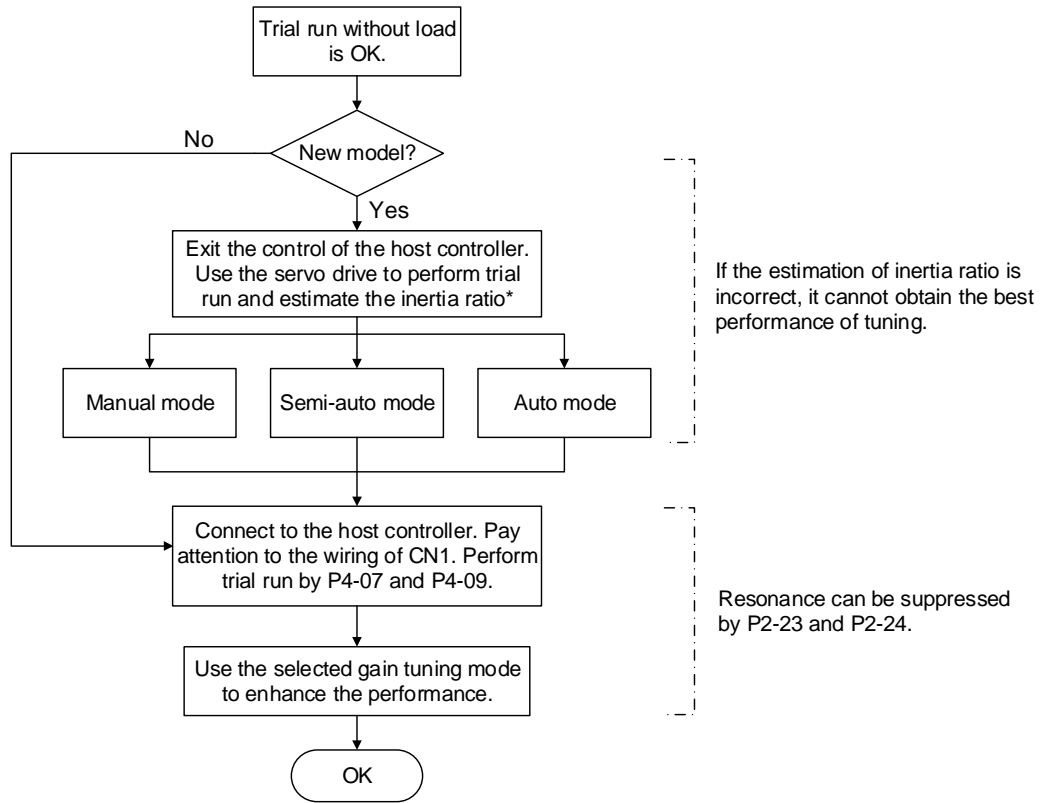

Note: The value of inertia ratio is used for rotary motors.

Figure 5-1 Tuning procedure

5

### 5.5.2 Inertia Estimation Flowchart (with Mechanism)

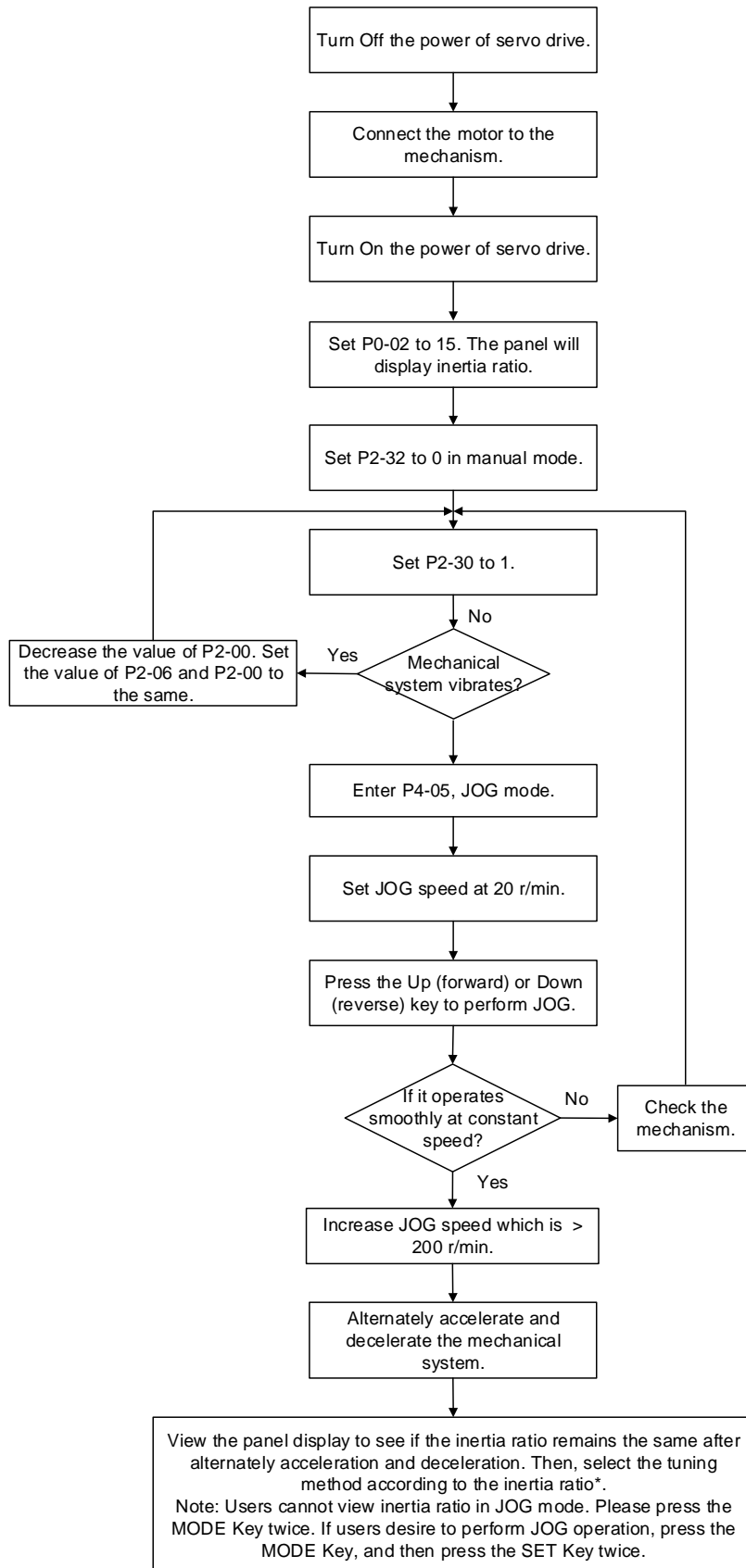

Note: The value of inertia ratio is used for rotary motors.

Figure 5-2 Inertia estimation

### 5.5.3 Flowchart of Auto Tuning

Please refer to the figure below to start the auto tuning procedure.

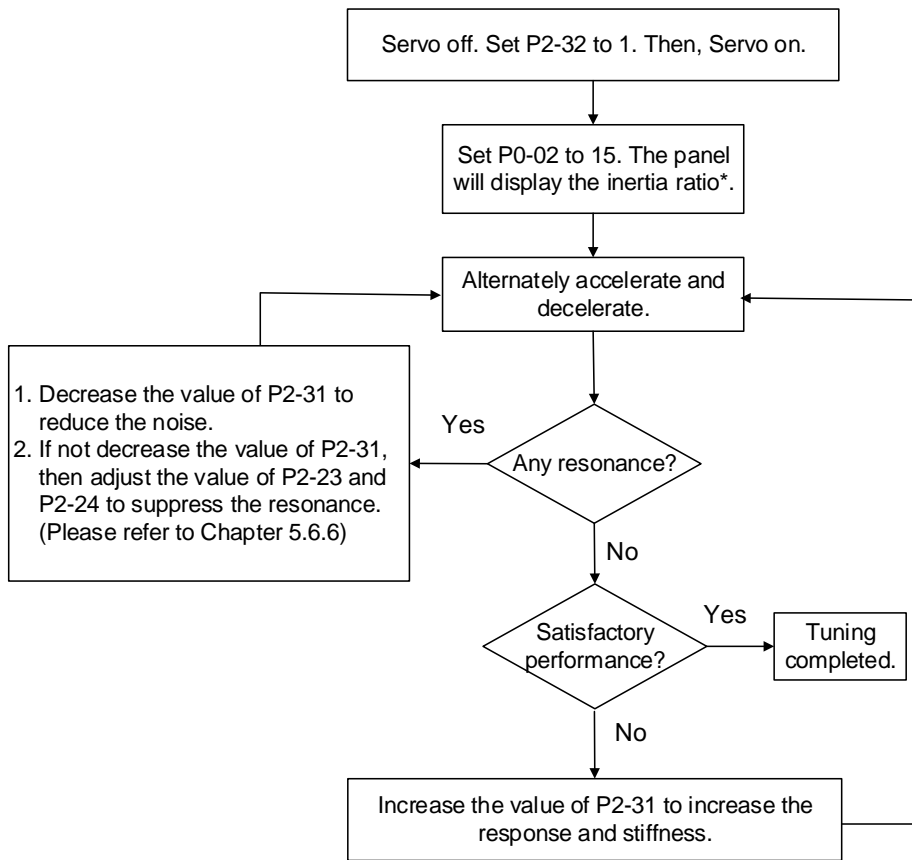

Note: The value of inertia ratio is used for rotary motors.

Figure 5-3 Tuning procedure in auto mode

Set P2-32 to 1 (auto mode, continuous tuning):

The servo will continue to estimate the system inertia. Then, it will automatically store the value in P1-37 every 30 minutes and refer the stiffness and bandwidth setting of P2-31.

Adjust the value of P2-31, Stiffness setting in auto tuning mode (The default value is 40):

Increase the value of P2-31 to increase stiffness or decrease to reduce noise. Please note that the higher the value is, the higher the stiffness will be. Continue to tune the system until the performance is satisfied. Then, tuning is completed.

In auto and semi-auto mode, the bandwidth setting of speed circuit is as follows.

- 1 ~ 50 Hz: low-stiffness, low-response
- 51 ~ 250 Hz: medium-stiffness, medium-response
- 251 ~ 850 Hz: high-stiffness, high-response

# 5

## 5.5.4 Flowchart of Semi-Auto Tuning

Please refer to the figure below to start the semi-auto tuning procedure.

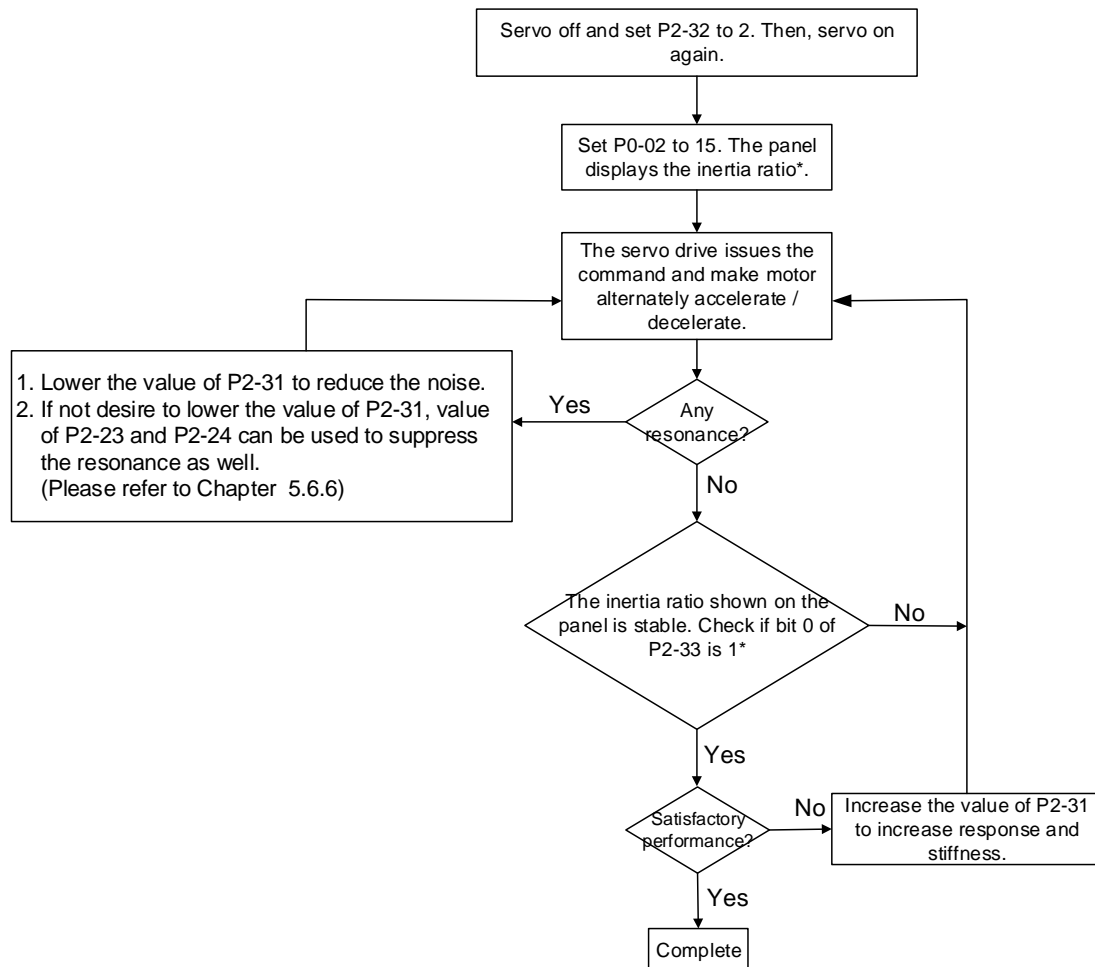

Figure 5-4 Procedure of tuning in semi-auto mode

Set P2-32 to 2. (semi-auto mode, non-continuous tuning)

After tuning for a while and wait until the system inertia is stable, it stops estimating. The estimated inertia ratio will be saved to P1-37. When switching mode from manual or auto to semi auto, the system starts tuning again. During the process of estimation, the system will refer to the stiffness and bandwidth setting of P2-31.

Adjust the value of P2-31, Response setting in auto mode (The default value is 40)

Increase the value of P2-31 to increase the response or decrease to reduce the noise. Continue to tune the system until the performance is satisfied. Response setting in semi-auto tuning mode: the higher the value is, the better the response will be. Then, tuning is completed.

In auto and semi-auto mode, the bandwidth setting of speed circuit is:

- 1 ~ 50 Hz: low-stiffness, low-response
- 51 ~ 250 Hz: medium-stiffness, medium-response
- 251 ~ 850 Hz: high-stiffness, high-response

Note:

1. If P2-33 bit 0 is set to 1, it means the inertia estimation in semi-auto mode is completed. The result can be accessed by P1-37.
2. If the value of P2-33 bit 0 is cleared to 0, the system will start to estimate again.

### 5.5.5 Limit of Inertia Ratio

Please see the limit of inertia ratio below during the estimation.

- Acceleration / Deceleration time of reaching 2000 r/min should be less than 1 second.
- The speed in forward and reverse direction should be higher than 200 r/min.
- The load inertia should be under 100 times of motor inertia.
- The change of external force of inertia ratio cannot be too severe.

In auto mode, the inertia value will be saved to P1-37 every 30 minutes; while in semi-auto mode, the inertia value will be saved to P1-37 only until the system inertia is stable and stops the estimation of load inertia.

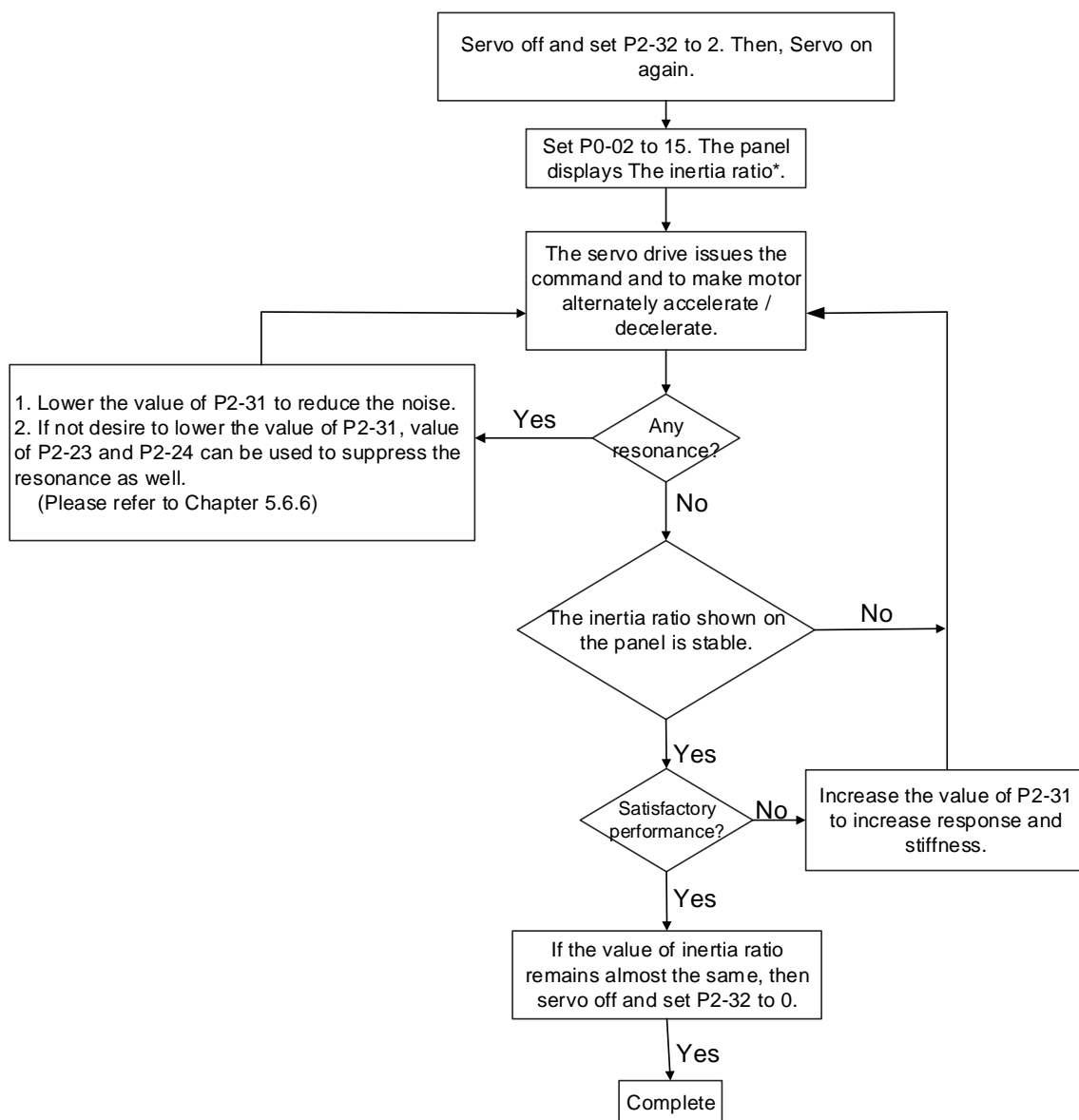

Figure 5-5 Estimation of load inertia

5

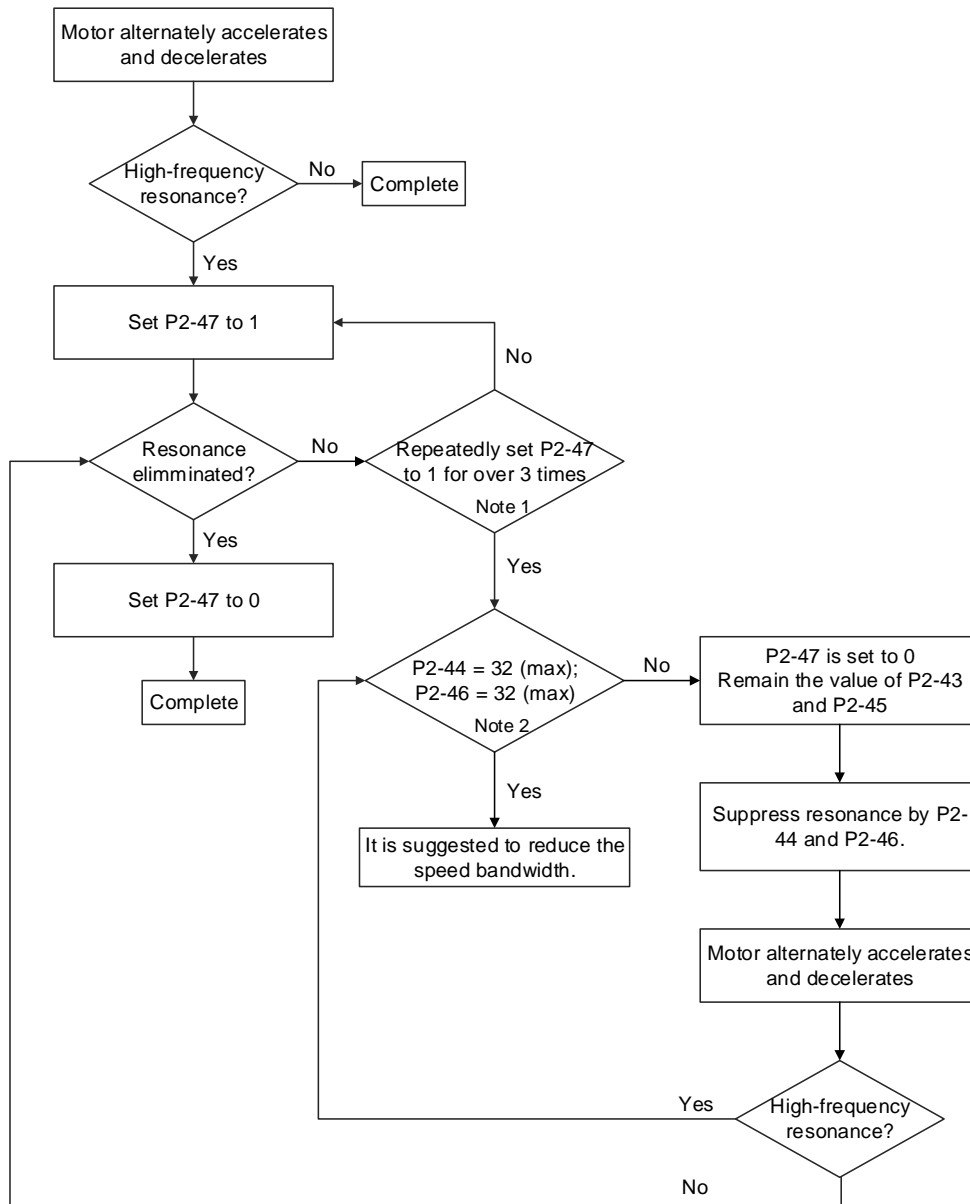

Figure 5-6 Procedure of auto suppressing the resonance

Note:

1. Resonance suppression is determined by parameter P2-44 and P2-46. If the value has been set to the maximum (32 dB), and still cannot suppress the resonance, please reduce the speed bandwidth. After setting P2-47, users can check the value of P2-44 and P2-46. If the value of P2-44 is not 0, it means the resonance frequency exists in the system. Then, users can access P2-43 to see the resonance frequency (Hz). When there is another resonance frequency, the information will be shown in P2-45 and P2-46.
2. If resonance still exists, repeatedly set P2-47 to 1 for more than 3 times and manually adjust the setting of resonance.

### 5.5.6 Mechanical Resonance Suppression Method

Three groups of Notch filter are provided to suppress mechanical resonance. Both two of them can be set to the auto resonance suppression and manual adjustment.

5

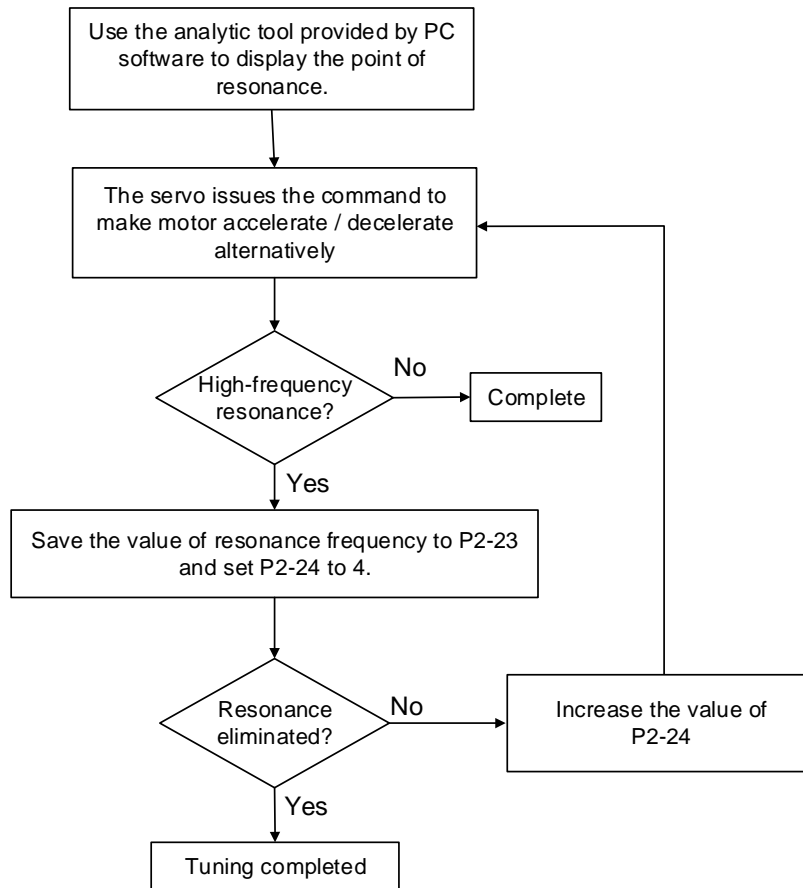

Figure 5-7 Procedure of manual suppressing the resonance

5

5.5.7 Tuning Mode and Parameters

Tuning mode	P2-32	Auto-set parameters	User-defined parameters	Inertia adjustment
Manual mode	0 (default)	N/A	P1-37(Inertia ratio of the motor) P2-00 (Position control gain) P2-04 (Speed control gain) P2-06(Speed integral compensation) P2-25(Low-pass filter of resonance suppression) P2-26 (Anti-interference gain)	The value remains
Auto mode (continuous estimation)	1	P1-37 P2-00 P2-04 P2-06 P2-25 P2-26 P2-49	P2-31 Frequency response of speed loop setting in auto mode (response level)	Continuous tuning (update the inertia every 30 minutes)
Semi-auto mode (non-continuous estimation)	2	P1-37 P2-00 P2-04 P2-06 P2-25 P2-26 P2-49	P2-31 Frequency response of speed loop setting in semi-auto mode (response level)	Non-continuous tuning (stop updating the inertia after operating for a while)

When switching mode from auto mode 1 to manual mode 0, the value of P2-00, P2-04, P2-06, P2-25, P2-26 and P2-49 will be modified to the one in auto mode.

When switching mode from semi-auto mode 2 to manual mode 0, the value of P2-00, P2-04, P2-06, P2-25, P2-26 and P2-49 will be modified to the one in semi-auto mode.

### 5.5.8 Tuning in Manual Mode

The selection of position / speed response frequency should be determined by the machinery stiffness and application. Generally, the high-frequency machinery or the one requires precise processing needs the higher response frequency. However, it might cause the resonance. Thus, use machinery with higher stiffness is needed so as to avoid resonance. When the permitted resonance frequency is unknown, users could gradually increase the gain setting value to increase the response frequency. Then, decrease the gain setting value until the resonance exists. The following are the descriptions about gain adjustment.

- Position Loop gain (KPP, parameter P2-00)

This parameter determines the response of position loop. Higher KPP value will make higher response frequency of position loop. And it will have better following, smaller position error, and shorter settling time. However, if the value is set too high, the machinery will vibrate or overshoot when positioning might occur. The calculation of position loop frequency response is as follows:

$$\text{Position Loop Frequency Response (Hz)} = \frac{KPP}{2\pi}$$

- Speed Loop gain (KVP, parameter P2-04)

This parameter determines the response of speed loop. Higher KVP value will make higher response frequency of speed loop and better following. However, if the value is set too high, it would cause machinery resonance. The response frequency of speed loop must be 4 ~ 6 times higher than the response frequency of position loop. Otherwise, the machinery might vibrate or overshoot when positioning might occur. The calculation of speed loop frequency response is as follows.

$$\text{Speed Loop Frequency Response } f_v = \left( \frac{KVP}{2\pi} \right) \times \left[ \frac{(1+P1-37/10)}{(1+JL/JM)} \right] \text{ Hz; JM: Motor Inertia;}$$

JL: Load Inertia; P1-37: 0.1 times

When P1-37 (estimation or setting) equals the real inertia ratio (JL/JM), the real speed loop frequency response will be:  $f_v = \frac{KVP}{2\pi}$  Hz

## 5

- Speed integral compensation (KVI, parameter P2-06)

The higher the KVI value is, the better capability of eliminating the deviation will be. However, if the value is set too high, it might easily cause vibration of machinery. It is suggested to set the value as follows.

$$KVI (P2 - 06) \leq 1.5 \times \text{Speed Loop Frequency Response}$$

- Low-pass filter of resonance suppression (NLP, parameter P2-25)

High value of inertia ratio will reduce the frequency response of speed loop. Therefore, the KVP value must be increased to maintain the response frequency. During the process of increasing KVP value, it might cause machinery resonance. Please use this parameter to eliminate the noise of resonance. The higher the value is, the better the capability of reducing high-frequency noise will be. However, if the value is set too big, it would cause the instability of speed loop and overshoot. It is suggested to set the value as the following:

$$NLP (P2 - 25) \leq \frac{1000}{6 \times \text{Speed Loop Frequency Response (Hz)}}$$

- Anti-interference gain (DST, parameter P2-26)

This parameter is used to strengthen the ability of resisting external force and gradually eliminate overshoot during acceleration / deceleration. Its default value is 0. It is suggested not to adjust the value in manual mode, unless it is for fine-tuning.

- Position feed forward gain (PFG, parameter P2-02)

It can reduce the position error and shorten the settling time. However, if the value is set too high, it might cause overshoot. If the setting value of e-gear ratio is higher than 10, it might cause the noise as well.

# Control Mode of Operation 6

---

This chapter describes operation structure of each control mode, including information about gain adjustment and filters. The operation of ASDA-B2-F is based on communication. Its position mode is controlled via DMCNET network and the speed mode and torque mode only accept commands from internal registers.

6.1	Selection of Operation Mode	6-2
6.2	Position Mode	6-3
6.2.1	Control Structure of Position Mode	6-3
6.2.2	S-curve Filter (Position)	6-4
6.2.3	Electronic Gear Ratio	6-5
6.2.4	Low-pass Filter	6-6
6.2.5	Gain Adjustment of Position Loop	6-6
6.2.6	Low-frequency Vibration Suppression in Position Mode	6-7
6.3	Speed Mode	6-10
6.3.1	Selection of Speed Command	6-10
6.3.2	Control Structure of Speed Mode	6-11
6.3.3	Smooth Speed Command	6-12
6.3.4	Timing Diagram of Speed Mode	6-13
6.3.5	Gain Adjustment of Speed Loop	6-14
6.3.6	Resonance Suppression	6-18
6.4	Torque Mode	6-23
6.4.1	Selection of Torque Command	6-23
6.4.2	Control Structure of Torque Mode	6-24
6.4.3	Smooth Torque Command	6-25
6.4.4	Timing Diagram of Torque Mode	6-25
6.5	The Use of Brake	6-26

## 6.1 Selection of Operation Mode

Three basic operation modes are provided in B2-F series servo drive, position, speed and torque. The following table lists all the operation modes and the related descriptions.

6

Mode Name		Short Name	Setting Code	Description
Single Mode	Position Mode	DMC	b	The servo drive receives position command from the controller and commands the motor to run to the target position.
	Speed Mode (No analog input)	Sz	04	The servo drive receives speed command and commands the motor to run at target speed. Speed command can only be issued by register (3 sets of register in total) and uses DI signal to select the register.
	Torque Mode (No analog input)	Tz	05	The servo drive receives torque command and commands the motor to target torque. Torque command can only be issued by register (3 sets of register in total) and uses DI signal to select the register.

Steps of changing mode:

1. Set DI.SON to OFF to switch the servo drive to Servo Off status.
2. Set the above setting code in the control mode setting of P1-01. Please refer to Chapter 7 for further description.
3. After the setting is completed, turn off the power and restart the drive again.

The following sections describe the operation of each mode, including mode structure, command source, selection and process of command and gain adjustment.

## 6.2 Position Mode

Position mode can be used in the application which requires precise positioning function, such as machinery industry. ASDA-B2-F only provides position mode which can be controlled via communication network DMCNET.

### 6.2.1 Control Structure of Position Mode

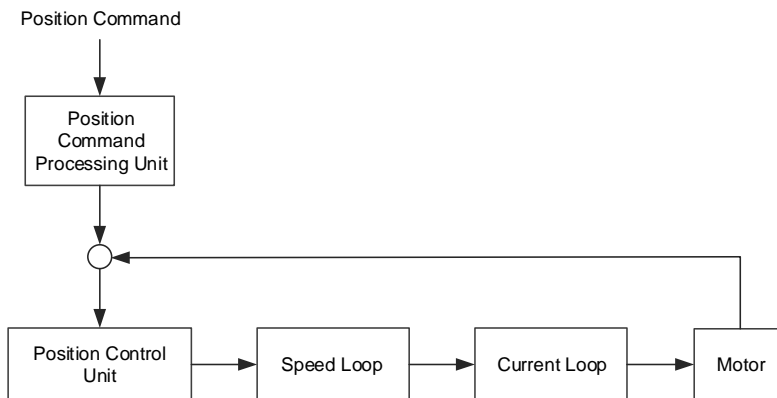

Figure 6-1 Basic Control Structure of Position Mode

For better control, the position command should be processed and modified through position command processing unit. The structure is shown as the figure below.

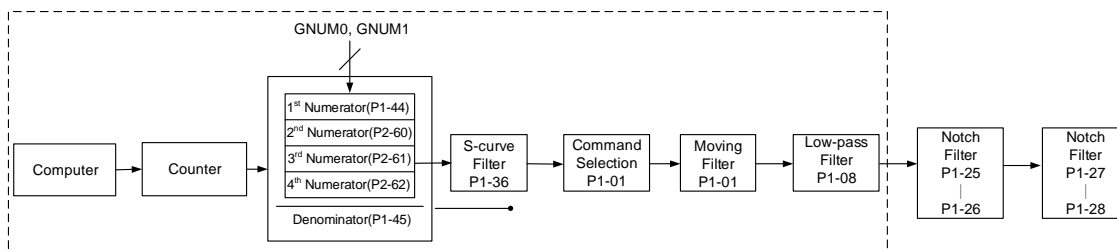

Figure 6-2 Position Command Processing Unit

E-Gear ratio can be set for proper positioning resolution. Moreover, either S-curve filter or low-pass filter can be used to smooth the command. See the description in later parts.

6

6.2.2 S-curve Filter (Position)

S-curve filter smoothes the motion command. With S-curve filter, the speed and the process of acceleration become more continuous and the jerk will be smaller. It not only improves the performance when motor accelerates/decelerates, but also smoothes the mechanical operation. If the load inertia increases, the operation of the motor will be influenced by friction and inertia when it starts or stops the rotation. The situation can be improved by increasing the value of acceleration/deceleration constant of S-curve (TSL), acceleration constant of S-curve (TACC) and deceleration constant of S-curve (TDEC).

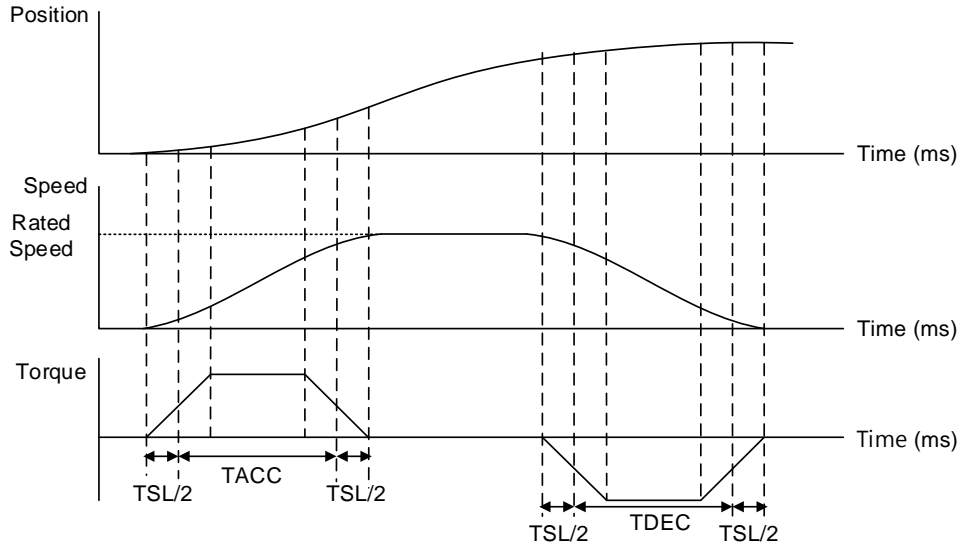

The relation among S-curve, position and speed  
(acceleration of position command)

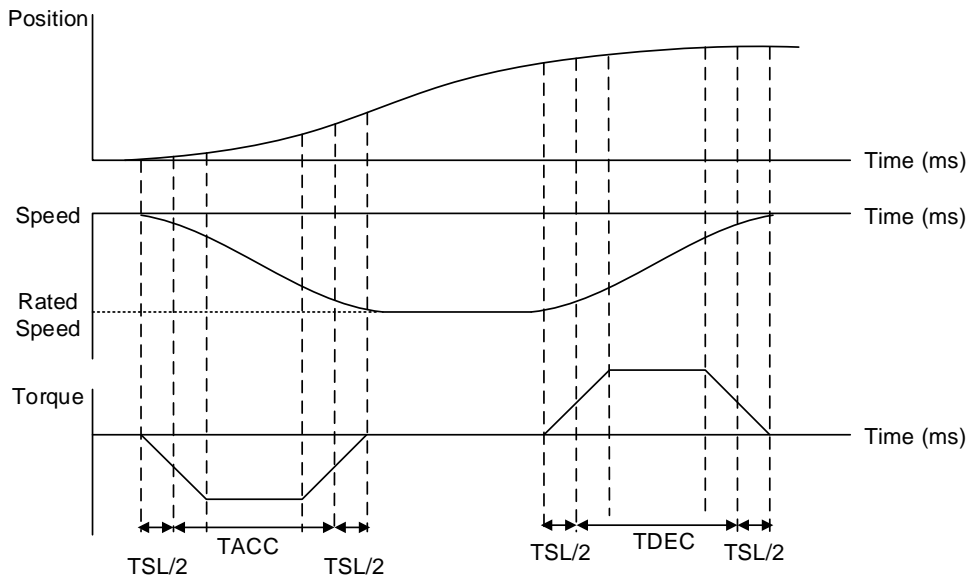

The relation among S-curve, position and speed  
(deceleration of position command)

Relevant Parameters (Please refer to Chapter 7 for detailed description):

Parameter	Abbr.	Function
P1-34	TACC	Acceleration Constant of S-Curve
P1-35	TDEC	Deceleration Constant of S-Curve
P1-36	TSL	Acceleration/Deceleration Constant of S-Curve

### 6.2.3 Electronic Gear Ratio

Relevant Parameters (Please refer to Chapter 7 for detailed description):

Parameter	Abbr.	Function
P1-44	GR1	Gear Ratio (Numerator) (N1)
P1-45	GR2	Gear Ratio (Denominator) (M)

Electronic Gear Ratio =  $\left(\frac{N}{M}\right) = \frac{P1-44}{P1-45}$  has to match  $\frac{1}{50} \leq \frac{N}{M} \leq 5000$

Electronic gear provides simple ratio change of travel distance. The high electronic gear ratio would cause the position command to be stepped command. S-curve or low-pass filter can be used to improve the situation. When electronic gear ratio is set to 1, the motor will run one turn every 10000 PPR. When electronic gear ratio is changed to 0.5, then every two pulses from the command will be referred to one PUU of the motor encoder.

For example, after setting the electronic gear ratio properly, the moving distance of the object is 1 μm/pulse, which is easier to use.

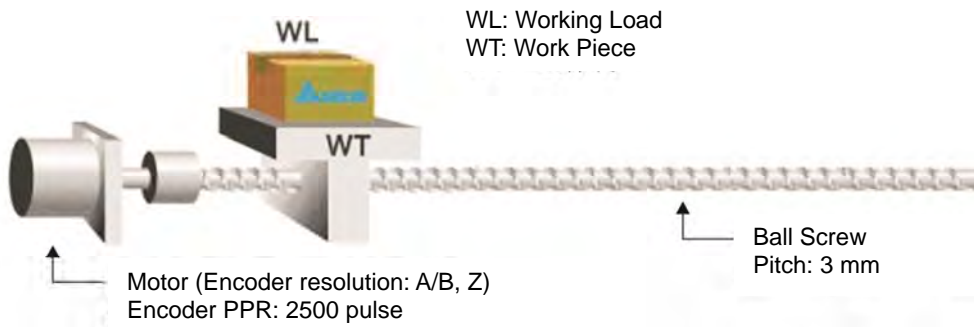

-	Gear Ratio	Moving Distance of Each Pulse Command
Electronic gear is not applied.	$\frac{1}{1}$	$= \frac{3 \times 1000}{4 \times 2500} = \frac{3000}{10000} = \mu m$
Electronic gear is applied.	$\frac{10000}{3000}$	$= 1 \mu m$

## 6

### 6.2.4 Low-pass Filter

Relevant Parameters (Please refer to Chapter 7 for detailed description):

Parameter	Abbr.	Function
P1-08	PRLT	Smooth Constant of Position Command (Low-pass Filter)
P1-45	GR2	Gear Ratio (Denominator) (M)

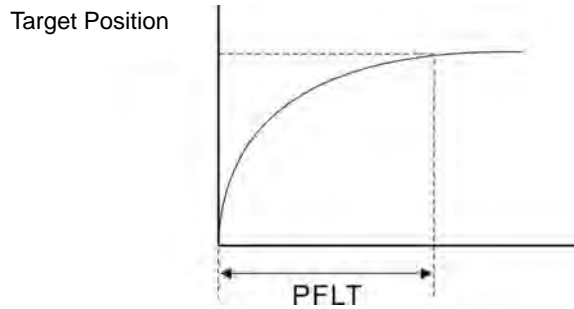

### 6.2.5 Gain Adjustment of Position Loop

Before setting the position control unit, users have to manually complete the setting of tuning mode selection (P2-32) since the speed loop is included in position loop. Then, set the position loop gain (P2-00) and position feed forward gain (P2-02). Users also can use the auto mode to automatically set the gain of speed and position control unit.

1. Proportional gain: Increase the gain so as to enhance the response bandwidth of position loop.
2. Feed forward gain: Minimize the deviation of phase delay.

The position loop bandwidth cannot exceed the speed loop bandwidth. It is suggested that:

$$f_p \leq \frac{f_v}{4}. \quad f_v: \text{response bandwidth of speed loop (Hz)}.$$

$$KPP = 2 \times \pi \times f_p. \quad f_p: \text{response bandwidth of position loop (Hz)}.$$

For example: the desired position bandwidth is 20 Hz  $\rightarrow KPP = 2 \times \pi \times 20 = 125$ .

Relevant Parameters (Please refer to Chapter 7 for detailed description):

Parameter	Abbr.	Function
P2-00	KPP	Position Loop Gain
P2-02	PPG	Position Feed Forward Gain

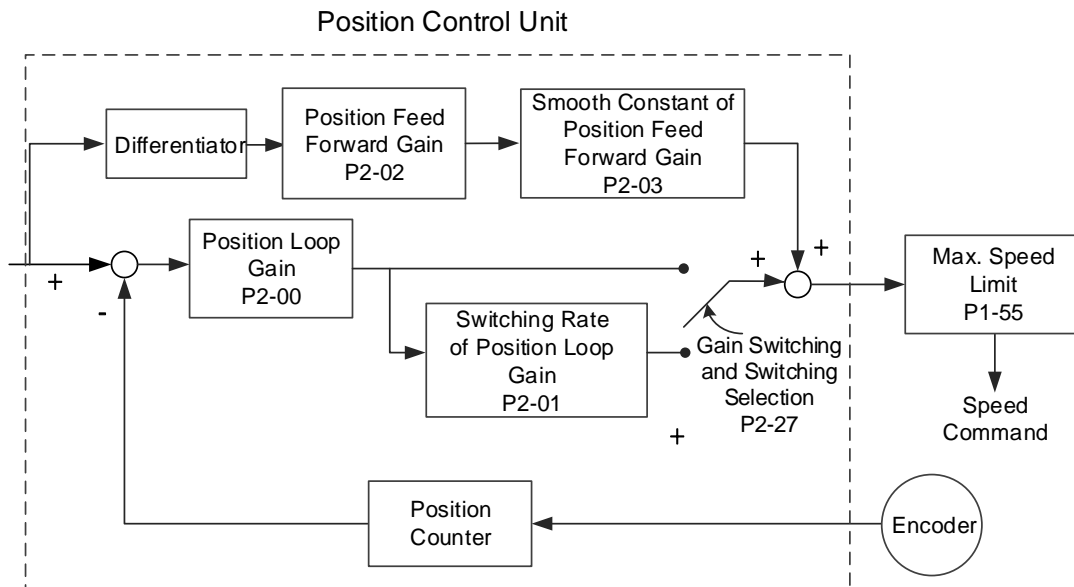
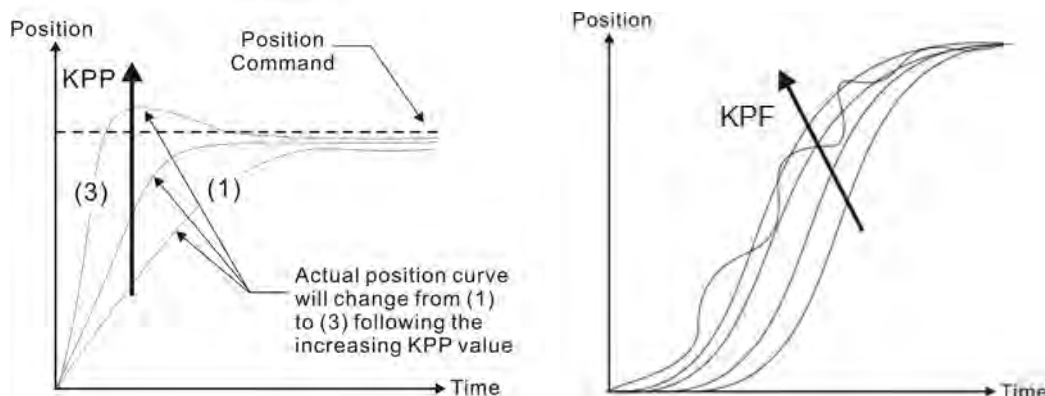

Figure 6-3 Position Control Unit

When the value of KPP is set to be too large, the bandwidth of position loop will be increased and diminish the phase margin. And the motor rotor rotates vibrantly in forward and reverse direction at the moment. Thus, KPP has to be decreased until the rotor stops vibrating. When the external torque interrupts, the over-low KPP cannot meet the demand of reducing position error. In this situation, parameter P2-02 may help which can effectively reduce the position error.



### 6.2.6 Low-frequency Vibration Suppression in Position Mode

If the system stiffness is not enough, the mechanical transmission will continue vibrating even when the motor stops and the positioning command is completed. The function of low-frequency vibration suppression can eliminate the vibration of mechanical transmission. The range of low-frequency vibration suppression is from 1.0Hz to 100.0HZ. Manual setting and auto setting are provided for this function.

Auto setting:

If the frequency is hard to find, user can enable the function of auto low-frequency vibration suppression. This function automatically searches the frequency of low-frequency vibration. If P1-29 is set to 1, the system will disable the function of low-frequency vibration suppression automatically and starts to search for the vibration frequency. When the detected frequency remains at the same level, P1-29 will be set to 0 automatically and set the first frequency to P1-25 and set P1-26 to 1. The second frequency will be set to P1-27 and then set P1-28 to 1. If P1-29 is automatically set back to 0 and low-frequency vibration still exists, please check if the function of P1-26 or P1-28 is enabled. If the value of P1-26 and P1-28 are 0, it means no

frequency has been detected. Please decrease the value of P1-30 and set P1-29 to 1 so as to search for the vibration frequency again. Please note that when the detection level is set to be too small, the noise may be regarded as the frequency of low-frequency vibration.

6

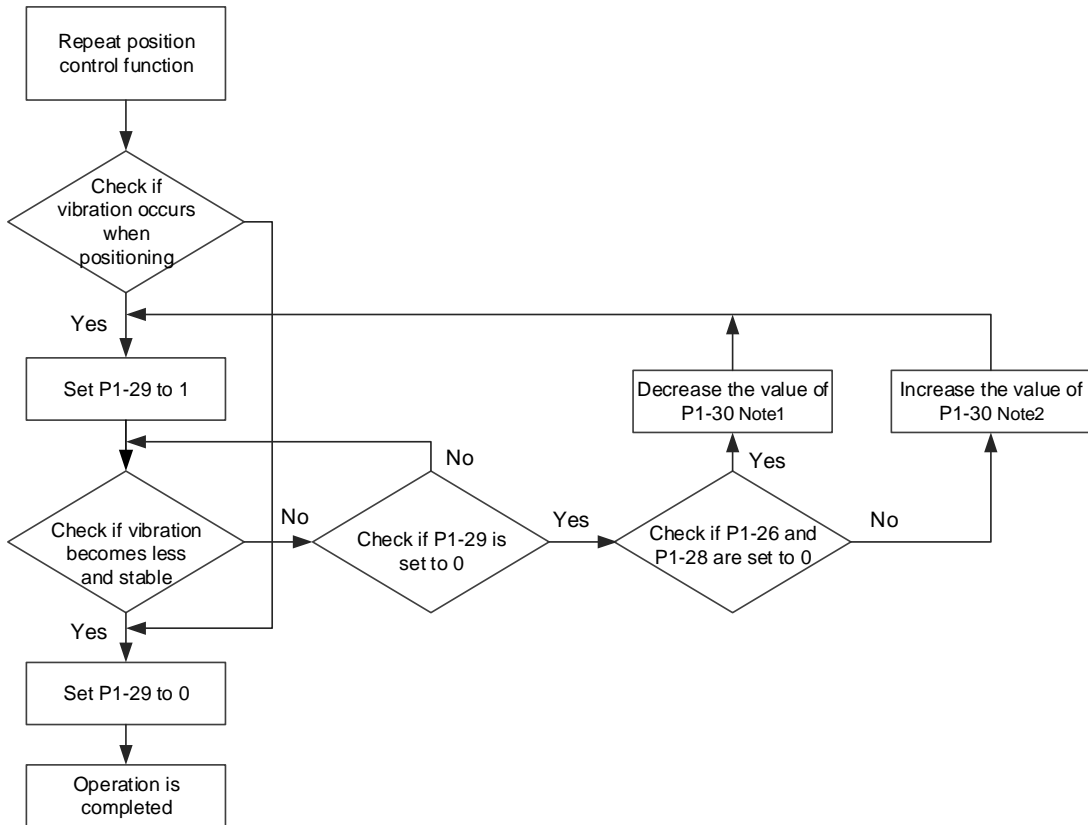

Figure 6-4 Procedure of Auto Low-frequency Vibration Suppression

**Note:**

1. When the value of P1-26 and P1-28 are both 0, it means it is unable to search for the frequency. It is probably because the detection level is set to be too high and is unable to detect the frequency of low-frequency vibration.
2. When the value of P1-26 or P1-28 is not 0 and the vibration still cannot be diminished, it is probably because the detection level is set to be too low, the system regards the noise or other non-primary frequency as the frequency of low-frequency vibration.
3. When the process of auto vibration suppression is completed and the vibration still cannot be diminished, P1-25 or P1-27 can be manually set to suppress the vibration if the frequency of the low-frequency vibration is identified.

Relevant Parameters of Auto Vibration Suppression (Please refer to Chapter 7 for detailed description):

Parameter	Abbr.	Function
P1-29	AVSM	Auto Low-frequency Vibration Suppression Setting
P1-30	VCL	Low-frequency Vibration Detection

P1-30 is to set the range to detect the magnitude of low-frequency vibration. When the frequency is not being detected, it is probably because the value of P1-30 is set to be too large which exceeds the range of vibration. It is suggested to decrease the value of P1-30. Please note that if the value is too small, the system might regard the noise as the vibration frequency. If the scope is available, it can be used to observe the range of position error (pulse) between upper and lower magnitude in order to set up the appropriate value of P1-30.

Manual Setting:

There are two sets of low-frequency vibration suppression. One is parameter P1-25 and P1-26 and the other one is parameter P1-27 and P1-28. These two sets of low-frequency vibration suppression can be used to eliminate low-frequency vibration with two different frequencies. Parameter P1-25 and P1-27 are used to set the frequency of low-frequency vibration. The function is working only when the parameter setting value of low-frequency vibration suppression is close to the real vibration frequency. Parameter P1-26 and P1-28 are used to set the response after being processed by the filter. The bigger the setting value of P1-26 and P1-28 is, the better the response will be. However, if the value is set to be too large, the motor might not operate smoothly. The default value of parameter P1-26 and P1-28 are 0, which means the function is disabled.

Relevant Parameters (Please refer to Chapter 7 for detailed description):

Parameter	Abbr.	Function
P1-25	VSF1	Low-frequency Vibration Suppression (1)
P1-26	VSG1	Low-frequency Vibration Suppression Gain (1)
P1-27	VSF2	Low-frequency Vibration Suppression (2)
P1-28	VSG2	Low-frequency Vibration Suppression Gain (2)

## 6

## 6.3 Speed Mode

Speed control mode is applicable in situation which requires precise speed control, such as CNC machine tools. The command input of ASDA-B2-F is register. Two ways are provided to use register input. One is to set different values of speed command to the three registers before operation, and use DI.SP0 and SP1 in CN1 for switching. The other one is to change the value of register by communication. In order to deal with the problem of non-continuous speed command when switching between registers, a complete S-curve is provided. In closed-loop system, this servo drive adopts gain adjustment and integrated PI controller. Two operation modes (manual and auto) are also available.

Users can set all the parameters in manual mode and all the auto or auxiliary functions will be disabled. In auto mode, it provides functions of load inertia estimation and parameter adjustment. In auto mode, parameters set by users will be regarded as default values.

### 6.3.1 Selection of Speed Command

The source of speed command is from internal parameters. The selection is determined by DI signal of CN1. See as the followings:

Speed Command	CN1 DI Signal		Command Source			Content	Range
	SPD1	SPD0	Mode	Sz	N/A		
S1	0	0	Mode	Sz	N/A	Speed command is 0	0
S2	0	1	Parameter of internal register			P1-09	-60000 ~ 60000
S3	1	0				P1-10	-60000 ~ 60000
S4	1	1				P1-11	-60000 ~ 60000

- Status of SPD0 ~ SPD1: 0 means DI is OFF, 1 means DI is ON.
- When SPD0 = SPD1 = 0, speed command is 0.
- When one of SPD0 and SPD1 is not 0, the speed command source is the internal parameter. The command is activated right after changing the status of SPD0 ~ SPD1. There is no need to use CTRG as trigger.
- The setting range of the internal parameters is between -60000 to 60000. Setting value = Setting range x Unit (0.1r/min).

For example: P1-09 = +30000. Setting value = +30000 x 0.1r/min = +3000r/min

The speed command not only can be issued in speed mode, but also in torque mode as the speed limit.

### 6.3.2 Control Structure of Speed Mode

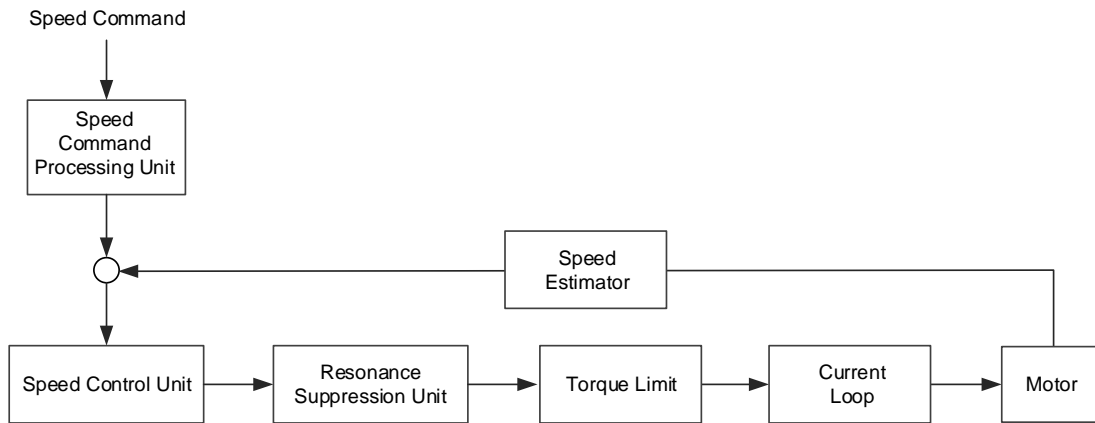

Figure 6-5 Basic Control Structure of Speed Mode

The speed command processing unit is to select speed command source according to Section 6.3.1, including the S-curve setting for smoothing speed command. The speed control unit manages the gain parameters of the servo drive and calculates the current command for servo motor in time. The resonance suppression unit is to suppress the resonance of the mechanism.

Here firstly introduce the function of speed command processing unit. Its structure is as the following figure:

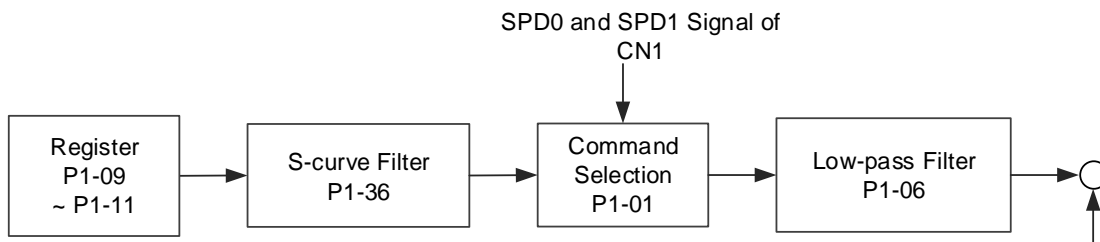

Figure 6-6 Structure of Speed Command

Usually, S-curve and low-pass filters are applied for having a smooth response of command.

### 6.3.3 Smooth Speed Command

#### S-curve Filter

During the process of acceleration or deceleration, S-curve filter applies the program of three-stage acceleration curve for smoothing the motion command, which generates continuous acceleration. It is for avoiding the jerk (the differentiation of acceleration) of sudden command change which further causes mechanical vibration and noise. Users can use acceleration constant of S-curve (TACC) to adjust the slope change during acceleration, deceleration constant of S-curve (TDEC) to adjust the slope change during deceleration and acceleration/deceleration constant of S-curve (TSL) to improve the status of motor when it starts/stops operating. The calculation of the time to complete the command is provided. T (ms) stands for operation time; S (r/min) means the absolute speed command which is the absolute value of the difference between initial speed and final speed.

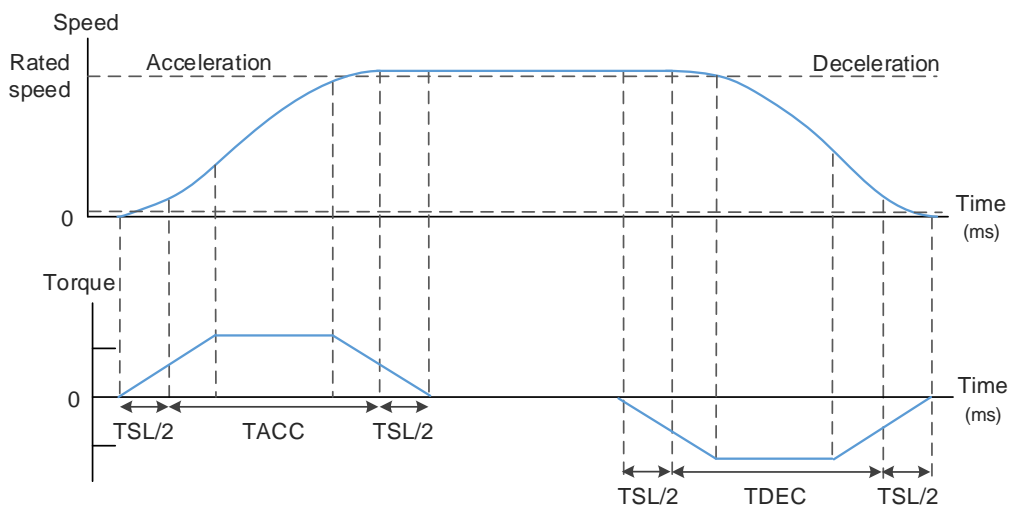

The relation between S-curve and speed

Relevant Parameters (Please refer to Chapter 7 for detailed description):

Parameter	Abbr.	Function
P1-34	TACC	Acceleration Constant of S-Curve
P1-35	TDEC	Deceleration Constant of S-Curve
P1-36	TSL	Acceleration/Deceleration Constant of S-Curve
P1-28	VSG2	Low-frequency Vibration Suppression Gain (2)

### Command End Low-pass Filter

It is usually used to eliminate the unwanted high-frequency response or noise. It also can smooth the command.

Relevant Parameters (Please refer to Chapter 7 for detailed description):

Parameter	Abbr.	Function
P1-06	SFLT	Acceleration/Deceleration Smooth Constant of Speed Command (Low-pass Filter)

6

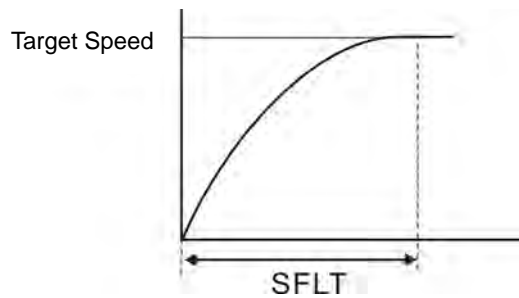

### 6.3.4 Timing Diagram of Speed Mode

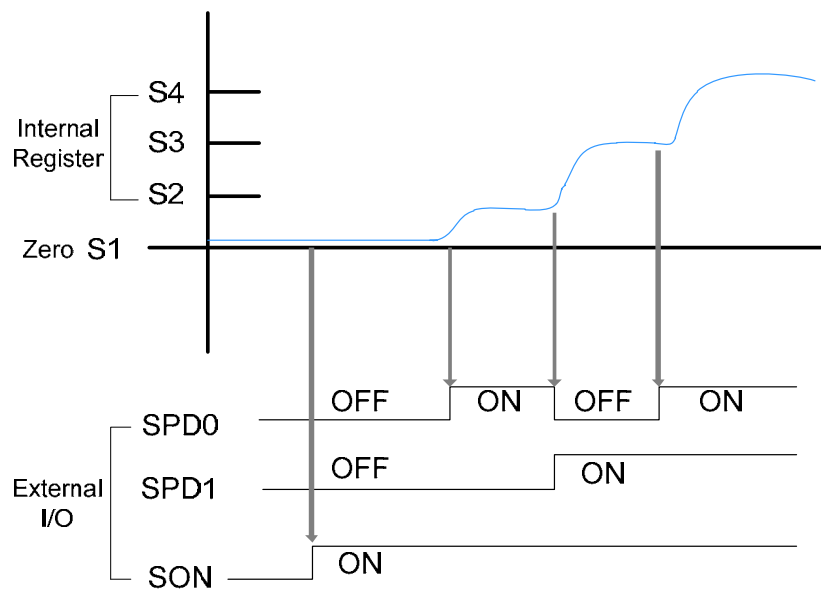

Figure 6-7 Timing Diagram of Speed Mode

- Note:
1. OFF means the contact is opened. ON means the contact is closed.
  2. Speed command S1 = 0.
  3. When Servo On, please select the command by switching the status of SPD0 ~ SPD1.

### 6.3.5 Gain Adjustment of Speed Loop

Here introduces the function of speed control unit. The following shows its structure:

6

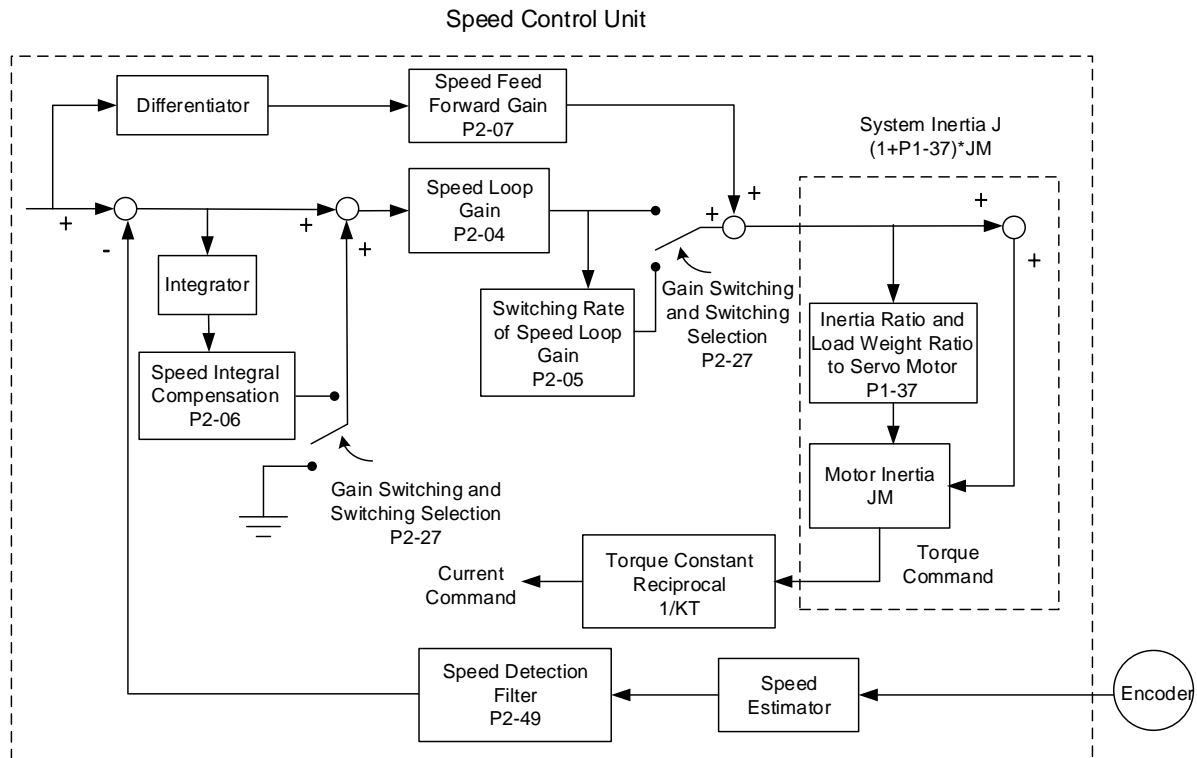

Figure 6-8 Structure of Speed Loop Gain Adjustment

Many kinds of gain in speed control unit are adjustable. Two adjustment ways (manual and auto) are provided for selection.

**Manual:** All parameters are set by users and all auto or auxiliary functions will be disabled in this mode.

**Auto:** General load inertia estimation is provided. It can adjust the parameter automatically. Its framework is divided into PI auto gain adjustment and PDFF auto gain adjustment.

Parameter P2-32 can be used to select the gain tuning method. (Please refer to Chapter 7 for detailed description):

Parameter	Abbr.	Function
P2-32	AUT2	Tuning Mode Selection

#### Manual Mode

When P2-32 is set to 0, users can define speed loop gain (P2-04), speed integral compensation (P2-06) and speed feed forward gain (P2-07). Function of each parameter is as the followings:

**Speed loop gain:** Increasing speed loop gain can enhance the response bandwidth of speed loop.

**Speed integral compensation:** Increasing the speed integral compensation can increase the low-frequency stiffness of speed loop and reduce the steady-state error as well as the phase margin. However, the over high integral gain will cause the instability of the system.

**Speed feed forward gain:** It can decrease the deviation of phase delay.

Relevant Parameters (Please refer to Chapter 7 for detailed description):

Parameter	Abbr.	Function
P2-04	KVP	Speed Loop Gain
P2-06	KVI	Speed Integral Compensation
P2-07	KVF	Speed Feed Forward Gain

Theoretically, stepping response can be used to explain speed loop gain (KVP), speed integral compensation (KVI) and speed feed forward gain (KVF). Descriptions of their basic principles are provided from the aspects of frequency domain and time domain.

**Frequency Domain**

STEP 1: Set the value of KVI=0, the value of KVF=0 and adjust the value of KVP.

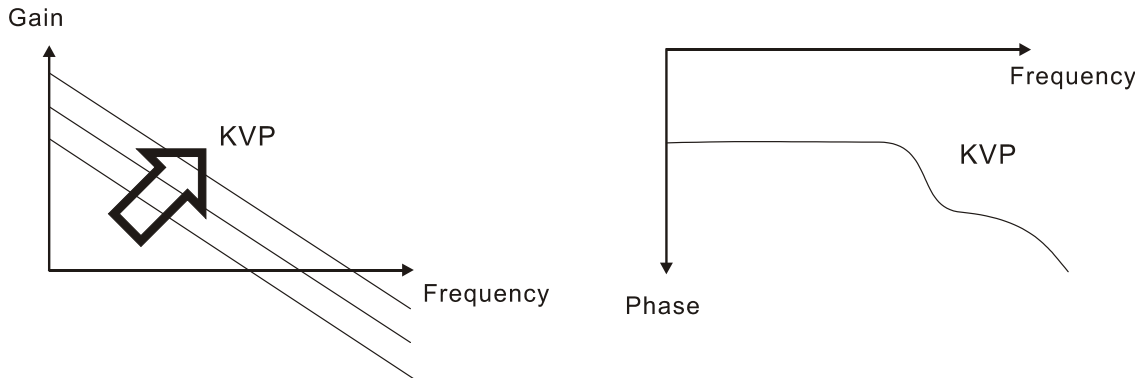

STEP 2 : Fix the value of KVP and adjust the value of KVI.

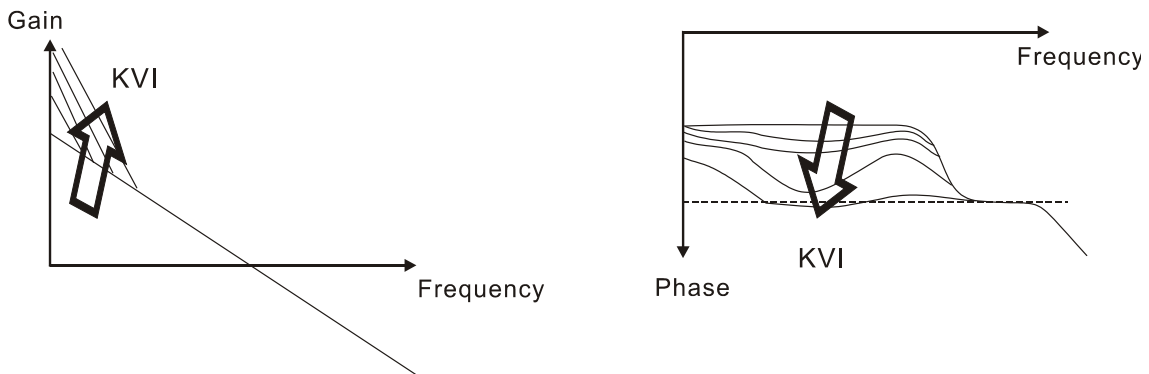

# 6

STEP 3 : Select the value of KVI, if the value of phase margin is too small, re-adjust the value of KVP again to obtain the value, 45deg of phase margin.

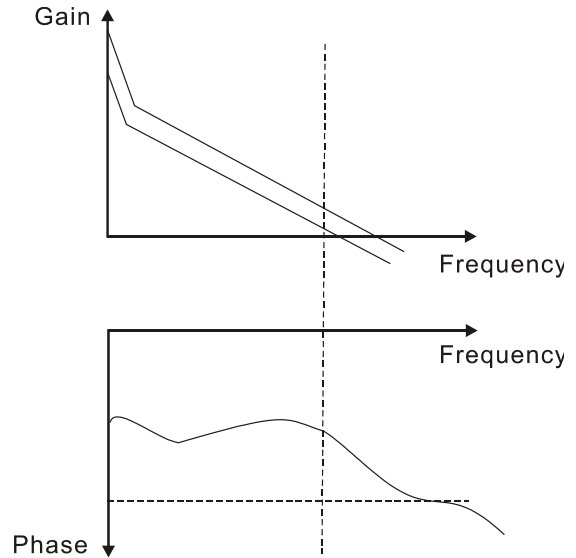

## Time Domain

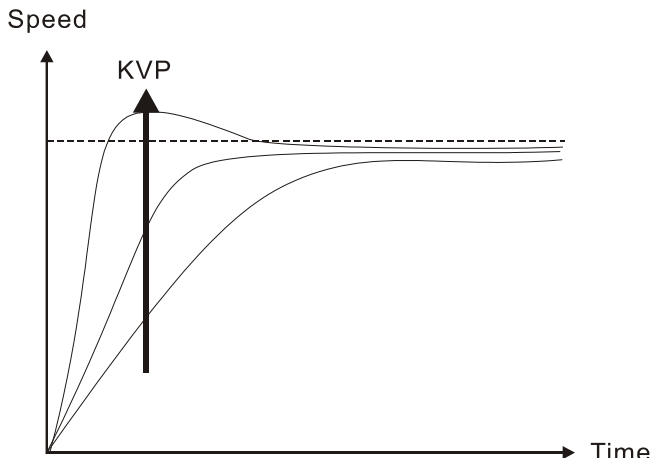

The bigger KVP value causes higher bandwidth and shortens the rising time. However, if the value is set to be too big, the phase margin will be too small. To steady-state following error, the result is not as good as KVI. But it helps to reduce the dynamic following error.

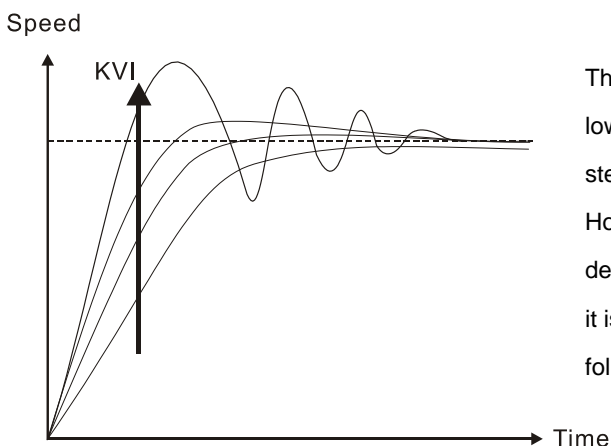

The bigger KVI value causes greater low-frequency gain and shortens the time the steady-state following error returns to zero. However, the phase margin will dramatically decrease as well. To steady-state following error, it is very helpful but shows no benefit to dynamic following error.

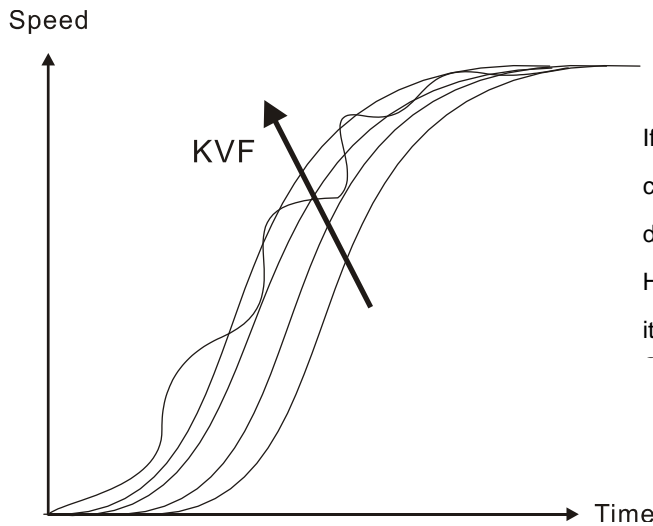

If the KVF value closes to 1, the feed forward compensation will be more complete and the dynamic following error will become smaller. However, if the KVF value is set to be too big, it would cause vibration.

Generally, instrument is needed when applying frequency domain for measurement. Users are required to adopt the measurement techniques; while time domain only needs a scope and goes with the analog input/output terminal provided by the servo drive. Thus, time domain is frequently used to adjust PI controller. The abilities of PI controller to deal with the resistance of torque load and the following command are the same.

That is to say, the following command and resistance of torque load have the same response performance in frequency domain and time domain. Users can reduce the bandwidth by setting the low-pass filter in command end.

**Auto Mode**

Auto mode adopts adaptive principle. The servo drive automatically adjusts the parameters according to the external load. Since the adaptive principle takes longer time, it will be unsuitable if the load changes too fast. It would be better to wait until the load inertia is steady or changes slowly. Depending on the speed of signal input, the adaptive time will be different from one another.

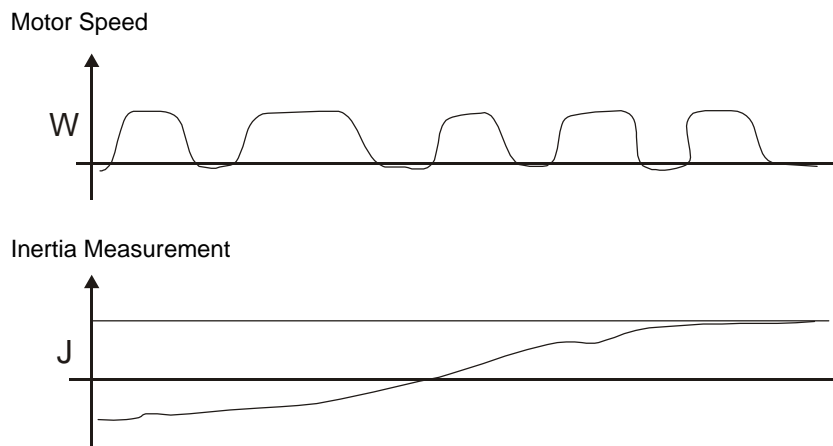

## 6

### 6.3.6 Resonance Suppression

When resonance occurs, it is probably because the stiffness of the control system is too strong or the response bandwidth is too fast. Eliminating these two factors might improve the situation. In addition, low-pass filter (P2-25) and notch filter (P2-23 and P2-24) are provided to suppress the resonance without changing the control parameters.

Relevant Parameters (Please refer to Chapter 7 for detailed description):

Parameter	Abbr.	Function
P2-23	NCF1	Resonance Suppression (Notch Filter) (1)
P2-24	DPH1	Resonance Suppression (Notch Filter) Attenuation Rate (1)
P2-43	NCF2	Resonance Suppression (Notch Filter) (2)
P2-44	DPH2	Resonance Suppression (Notch Filter) Attenuation Rate (2)
P2-45	NCF3	Resonance Suppression (Notch Filter) (3)
P2-46	DPH3	Resonance Suppression (Notch Filter) Attenuation Rate (3)
P2-25	NLP	Low-pass Filter of Resonance Suppression

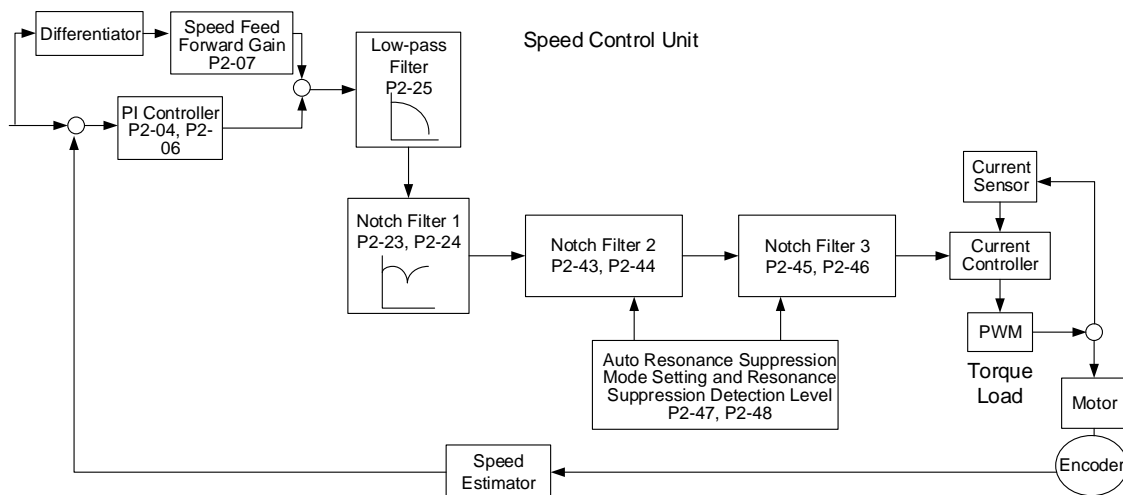

Figure 6-9 Resonance Suppression

There are two sets of notch filter for auto resonance suppression, one is P2-43 (resonance frequency) and P2-44 (attenuation rate) and the other one is P2-45 (resonance frequency) and P2-46 (attenuation rate). When the resonance occurs, set P2-47 to 1 or 2 (enable the function of auto resonance suppression), the servo drive will search for the point of resonance frequency and suppress the resonance automatically. This function will write the frequency point into P2-43 and P2-45 and the attenuation rate into P2-44 and P2-46. When P2-47 is set to 1, the system will set P2-47 to 0 (disable the function of auto suppression) automatically after resonance suppression is completed and the system is stable for 20 minutes. When P2-47 is set to 2, the system will keep searching for the resonance point.

When P2-47 is set to 1 or 2, but the resonance still exists, please check the value of parameter P2-44 and P2-46. If the one of the value is 32, it is suggested to reduce the speed bandwidth first and then start to estimate it again. If the both value are smaller than 32 and the resonance still exists, please set P2-47 to 0 first and then manually increase the value of P2-44 and P2-46. If the resonance situation has not been improved, it is suggested to reduce the bandwidth and then use the function of auto resonance suppression.

When manually increase the value of P2-44 and P2-46, please check if the value of both are

bigger than 0. If it is, it means the frequency points in P2-43 and P2-45 are the ones found by auto resonance suppression. If the value is 0, it means the value of 1000 in P2-43 and P2-45 are default values which are not the ones found by auto resonance suppression. Deepen the attenuation rate of the non-existed frequency point might worsen the situation.

Settings of P2-47		
Current Value	Desired Value	Function
0	1	Clear the setting value of P2-43 ~ P2-46 and enable the function of auto resonance suppression.
0	2	Clear the setting value of P2-43 ~ P2-46 and enable the function of auto resonance suppression.
1	0	Save the setting value of P2-43 ~ P2-46 and disable the function of auto resonance suppression.
1	1	Clear the setting value of P2-43 ~ P2-46 and enable the function of auto resonance suppression.
1	2	Do not clear the setting value of P2-43 ~ P2-46 and enable the function of auto resonance suppression continuously.
2	0	Save the setting value of P2-43 ~ P2-46 and disable the function of auto resonance suppression.
2	1	Clear the setting value of P2-43 ~ P2-46 and enable the function of auto resonance suppression.
2	2	Do not clear the setting value of P2-43 ~ P2-46 and enable the function of auto resonance suppression continuously.

6

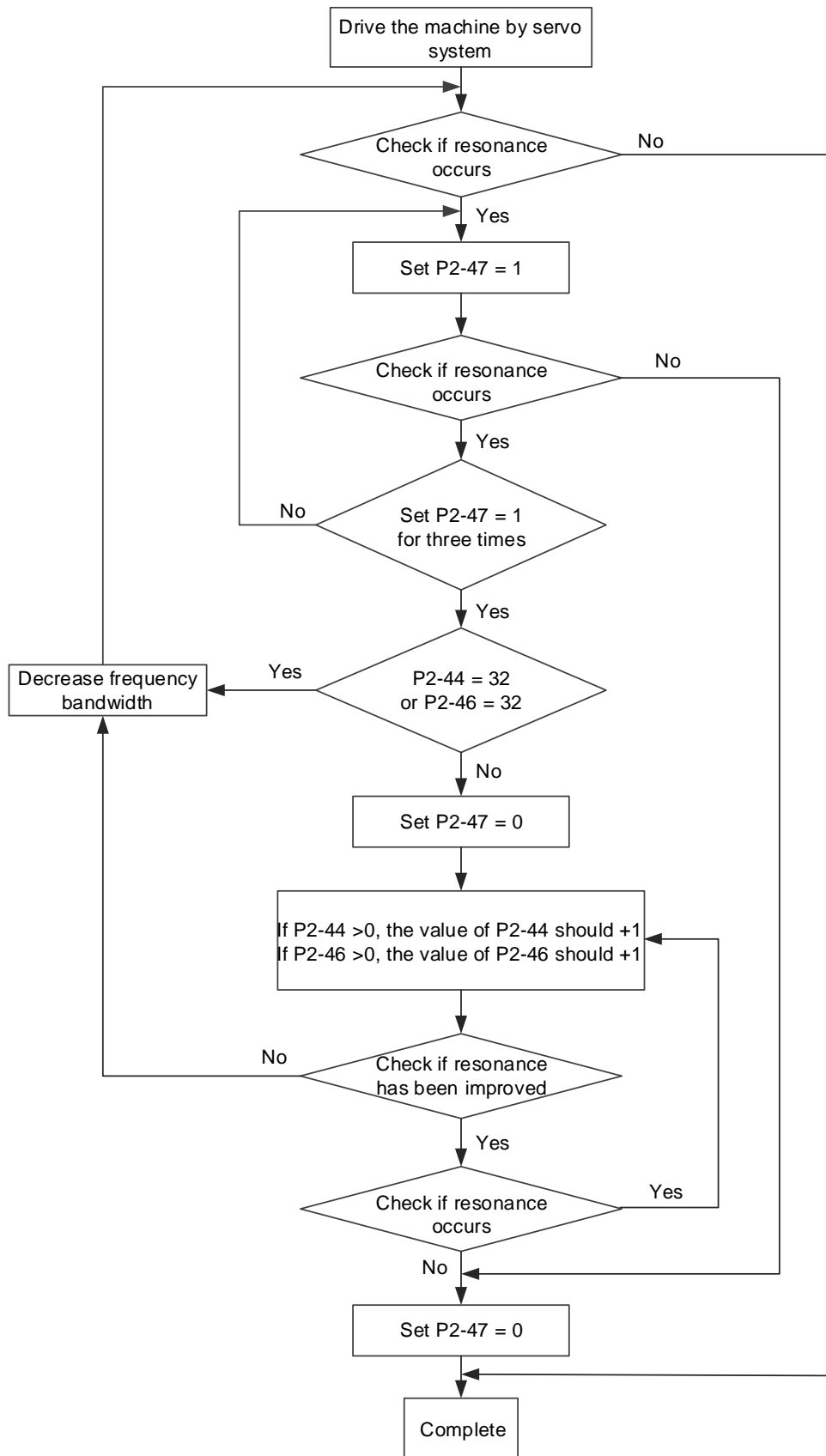
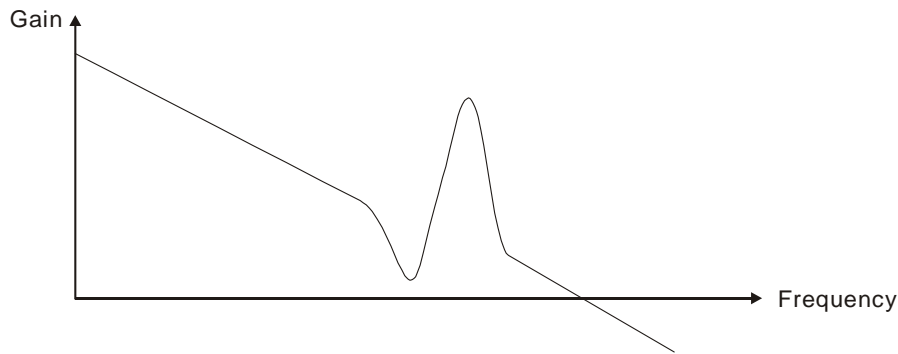
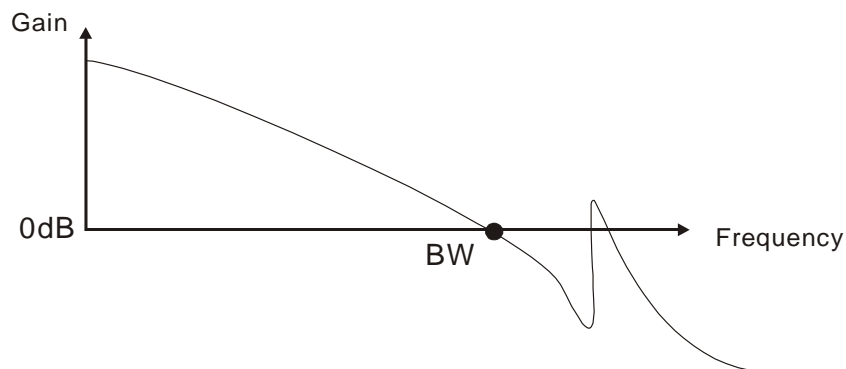

Figure 6-10 Procedure of Auto Resonance Suppression

Here illustrates the effect via low-pass filter (parameter P2-25). The following figure is the system open-loop gain with resonance.



When the value of low-pass filter (parameter P2-25) is increased from 0, BW becomes smaller (See the following figure). Although it improves the situation of resonance frequency, the response bandwidth and phase margin are reduced as well.



If users know the resonance frequency, notch filter (P2-23 and P2-24) can directly eliminate the resonance. The frequency setting range of the notch filter is merely from 50 to 1000 Hz. The suppression strength is from 0 to 32 dB. If the resonance frequency is not within the range, it is suggested to use low-pass filter (P2-25) to decrease the resonance intensity.

Here firstly illustrates the influence brought by notch filter (P2-23 and P2-24) and low-pass filter (P2-25). The following figures are the system of open-loop gain with resonance.

Resonance suppression with notch filter:

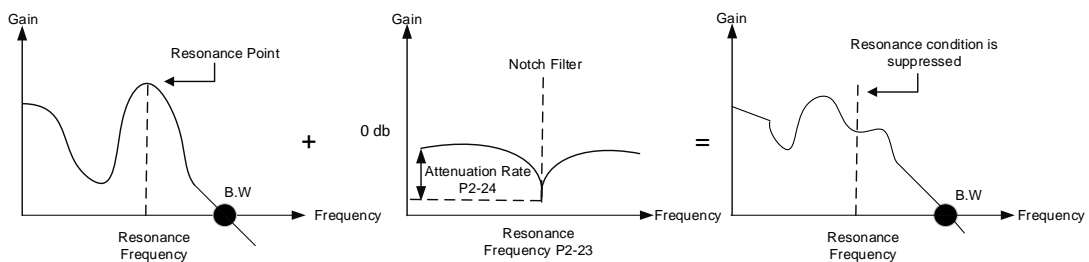

## Resonance suppression with low-pass filter:

6

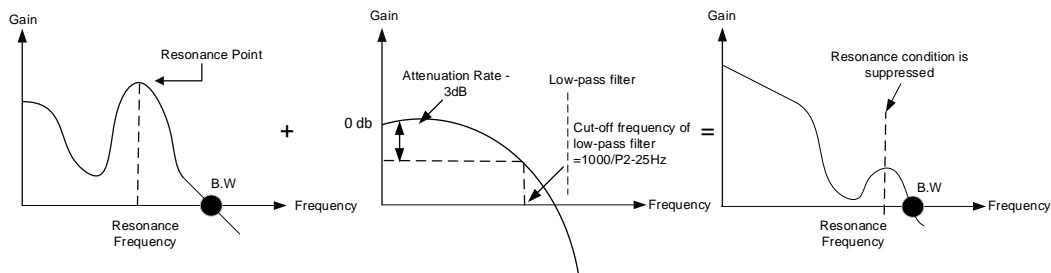

When the value of low-pass filter (P2-25) is increased from 0, B.W. becomes smaller. Although it improves the situation of resonance, the response bandwidth and phase margin are reduced as well. Also, the system becomes unstable. If users know the resonance frequency, notch filter (P2-23 and P2-24) can directly eliminate the resonance. In this case, notch filter will be more helpful than low-pass filter. However, if the resonance frequency drifts because of time or other factors, notch filter will not be preferable.

## 6.4 Torque Mode

Torque control mode is appropriate in torque control application, such as printing machine and winding machine. The command source is from register input which uses internal parameters (P1-12 ~ P1-14) as torque commands.

### 6.4.1 Selection of Torque Command

Torque commands come from the internal parameters of registers. Use DI signal of CN1 to select the command source.

Torque Command	DI Signal of CN1		Command Source			Content	Range
	TCM1	TCM0	Mode	Tz	None		
T1	0	0	Mode	Tz	None	Torque command is 0	0
T2	0	1	Parameter of internal register			P1-12	-300% ~ 300%
T3	1	0				P1-13	-300% ~ 300%
T4	1	1				P1-14	-300% ~ 300%

- The status of TCM0 ~ TCM1: 0 means DI is OFF; 1 means DI is ON.
- When TCM0 = TCM1 = 0, the command is 0.
- When one of TCM0 and TCM1 is not 0, the torque command source is from the internal parameter. The command is activated right after changing the status of TCM0 ~ TCM1. There is no need to use CTRG as trigger.

The torque command not only can be issued in torque mode, but also in speed mode as the torque limit.

## 6

## 6.4.2 Control Structure of Torque Mode

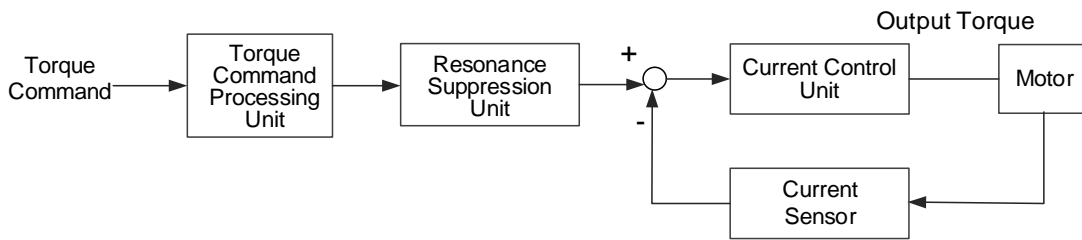

Figure 6-11 Basic Control Structure of Torque Mode

The torque command processing unit is to select torque command source according to Section 6.4.1, including the S-curve setting for torque command. The current control unit manages the gain parameters of the servo drive and calculates the current for servo motor in time. Since the current control unit is very complicated, and is not relevant to the application. There is no need to adjust the parameters, so only command end setting is provided.

The torque command processing unit is as the following figure.

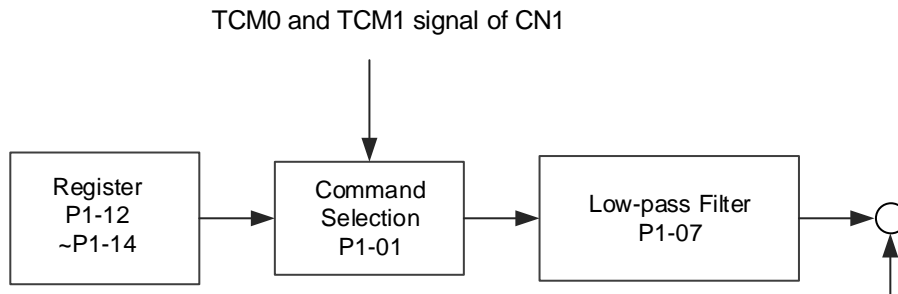

Figure 6-12 Structure of Torque Command

The command from internal register is selected according to the status of TCM0, TCM1 and P1-01. Low-pass filter is adopted for smoothing the performance to the command signal.

### 6.4.3 Smooth Torque Command

Relevant Parameters (Please refer to Chapter 7 for detailed description):

Parameter	Abbr.	Function
P1-07	TFLT	Smooth Constant of Torque Command (Low-pass Filter)

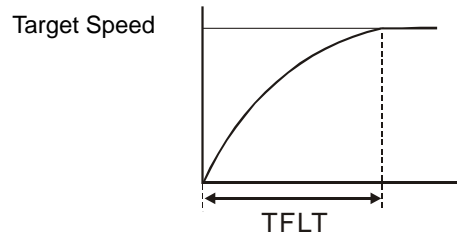

### 6.4.4 Timing Diagram of Torque Mode

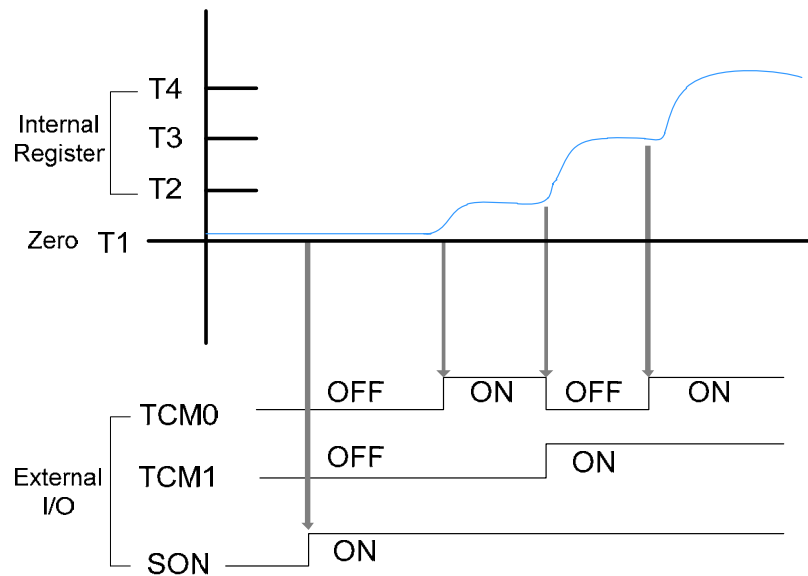

Figure 6-13 Timing Diagram of Torque Mode

Note:

1. OFF means the contact is opened; ON means the contact is closed.
2. Torque command T1 = 0.
3. When Servo On, please select the command by changing the status of TCM0~TCM1.

## 6

## 6.5 The Use of Brake

When operating brake via servo drive, if DO.BRKR is set to OFF, it means the brake is not working and the motor is locked. If DO.BRKR is set to ON, it means the brake is working and the motor can operate freely. The operation of brake has two kinds. Users can set delay time by MBT1 (P1-42) and MBT2 (P1-43). It is usually applied in Z axis in order to reduce the heat when servo motor puts up resistance which shorten its lifetime. In order to avoid the error of the brake, it must be operated when the servo drive is off. If users operate brake, the brake needs to be used during the decelerating process to make the braking force of the brake and the motor remain in the same direction. By doing so, the drive decelerates normally due to the braking force from the brake. If the brake is used when the drive is accelerating or at constant speed, the drive needs to generate greater current to resist the braking force which may cause the alarm of overload protection.

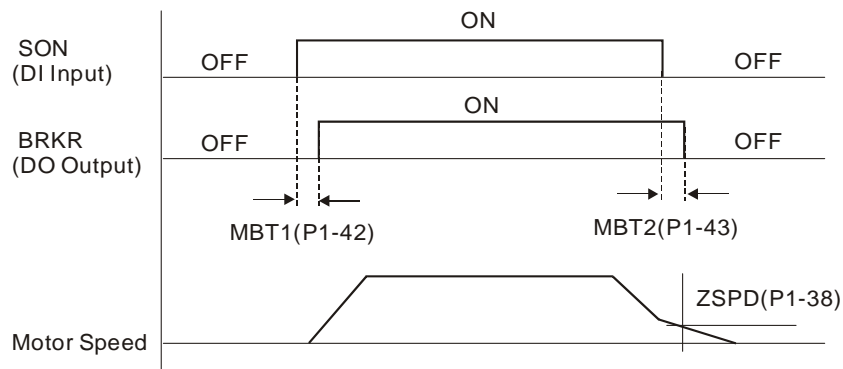

Figure 6-14 Timing Diagram of Brake

The output timing of DO.BRKR:

1. When Servo Off, motor goes through the time set by P1-43 and its speed is faster than the setting in P1-38, DO.BRKR is OFF (the brake is locked.).
2. When Servo Off, motor has not reached the time set by P1-43 but its speed is slower than the setting in P1-38, DO.BRKR is OFF (the brake is locked.).

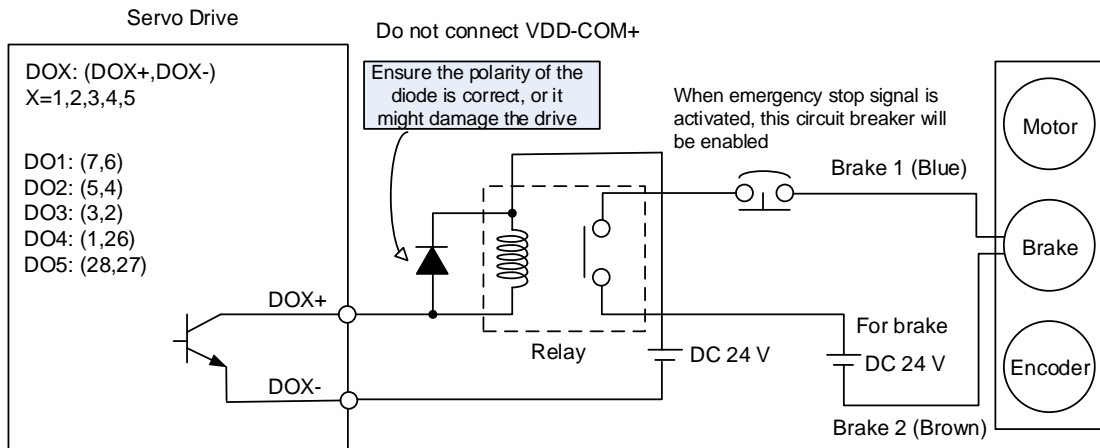

Figure 6-15 Wiring of brake

Note:

1. Please refer to Chapter 3 for wiring.
2. The brake signal controls the solenoid valve, provides power to the brake and enables the brake.
3. Please note that there is no polarity in coil brake.
4. Do not use the same mains to provide brake power and the control power (VDD).

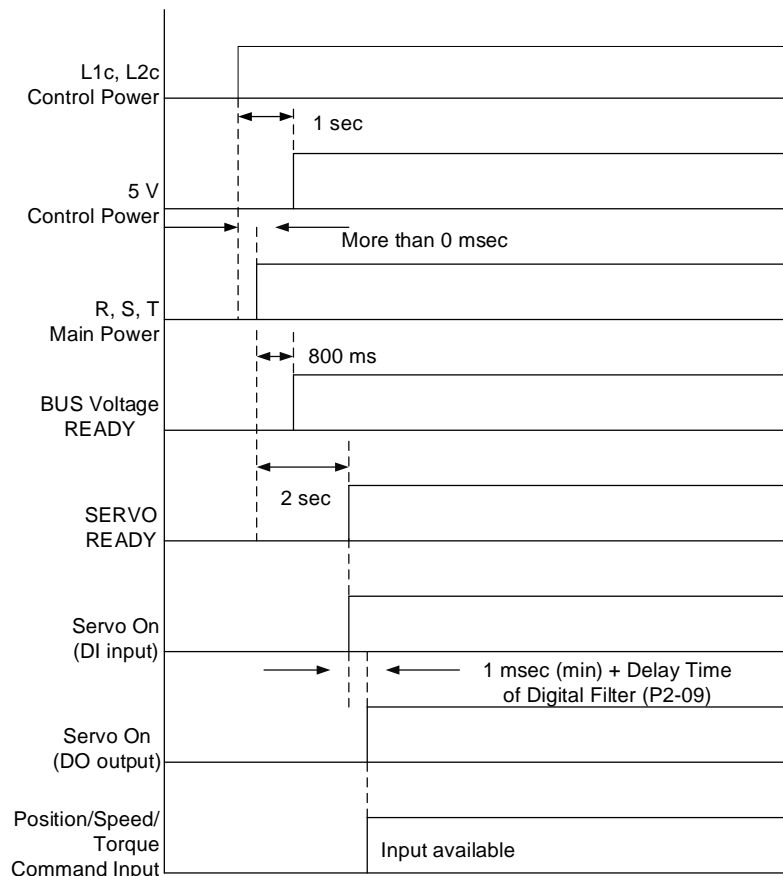

Figure 6-16 Timing Diagram of Control Power and Main Power

6

(This page is intentionally left blank.)

6

# Parameters

# 7

This chapter provides descriptions of parameter setting and definition of digital input (DI) and digital output (DO). Users can set functions via different parameters.

7.1	Parameter Definition .....	7-2
7.2	List of Parameters .....	7-3
7.3	Parameter Description .....	7-10
P0-xx	Monitor Parameters .....	7-10
P1-xx	Basic Parameters .....	7-22
P2-xx	Extension Parameters .....	7-37
P3-xx	Communication Parameters.....	7-50
P4-xx	Diagnosis Parameters .....	7-55
P5-xx	Motion Setting Parameters .....	7-59
Table 7.1	Function Description of Digital Input (DI) .....	7-63
Table 7.2	Function Description of Digital Output (DO).....	7-65

## 7

## 7.1 Parameter Definition

Parameters are divided into five groups which are shown as follows. The first character after the start code P is the group character and the following two characters are parameter character. As for the communication address, it is the combination of group character along with two digit numbers in hexadecimal format. The definition of parameter groups is as the followings:

- Group 0: Monitor parameters (example: P0-xx)
- Group 1: Basic parameters (example: P1-xx)
- Group 2: Extension parameters (example: P2-xx)
- Group 3: Communication parameters (example: P3-xx)
- Group 4: Diagnosis parameters (example: P4-xx)
- Group 5: Motion control parameters (example: P5-xx)

### Control Mode Description

- Sz: Speed control mode
- Tz: Torque control mode
- DMC: DMCNET control mode

### Special Symbol Description

- (★) Read-only register, can only read the status. For example: P0-00, P0-10 and P4-00, etc.
- (▲) Setting is invalid when Servo On, e.g. P1-00, P1-46 and P2-33, etc.
- (●) Not effective until re-power on or off the servo drive, e.g. P1-01 and P3-00.
- (■) Parameters of no data retained setting, e.g. P2-31 and P3-06.

## 7.2 List of Parameters

Monitor and General Output Parameter								
Parameter	Abbr.	Function	Default	Unit	Control Mode			Related Section
					DMC	Sz	Tz	
P0-00★	VER	Firmware Version	Factory Setting	-	○	○	○	-
P0-01■	ALE	Alarm Code Display of Drive (Seven-segment Display)	-	-	○	○	○	9.1 9.2 9.3
P0-02	STS	Drive Status	00	-	○	○	○	-
P0-08★	TSON	Servo On Time	0	Hour				-
P0-09★	CM1	Status Monitor Register 1	-	-	○	○	○	4.3.5
P0-10★	CM2	Status Monitor Register 2	-	-	○	○	○	4.3.5
P0-11★	CM3	Status Monitor Register 3	-	-	○	○	○	4.3.5
P0-12★	CM4	Status Monitor Register 4	-	-	○	○	○	4.3.5
P0-13★	CM5	Status Monitor Register 5	-	-	○	○	○	4.3.5
P0-17	CM1A	Status Monitor Register 1 Selection	0	-				-
P0-18	CM2A	Status Monitor Register 2 Selection	0	-				-
P0-19	CM3A	Status Monitor Register 3 Selection	0	-				-
P0-20	CM4A	Status Monitor Register 4 Selection	0	-				-
P0-21	CM5A	Status Monitor Register 5 Selection	0	-				-
P0-25	MAP1	Mapping Parameter # 1	No need to initialize	-	○	○	○	4.3.5
P0-26	MAP2	Mapping Parameter # 2	No need to initialize	-	○	○	○	4.3.5
P0-27	MAP3	Mapping Parameter # 3	No need to initialize	-	○	○	○	4.3.5
P0-28	MAP4	Mapping Parameter # 4	No need to initialize	-	○	○	○	4.3.5
P0-29	MAP5	Mapping Parameter # 5	No need to initialize	-	○	○	○	4.3.5
P0-30	MAP6	Mapping Parameter # 6	No need to initialize	-	○	○	○	4.3.5
P0-31	MAP7	Mapping Parameter # 7	No need to initialize	-	○	○	○	4.3.5
P0-32	MAP8	Mapping Parameter # 8	No need to initialize	-	○	○	○	4.3.5
P0-35	MAP1A	Target Setting of Mapping Parameter P0-25	0	-	○	○	○	4.3.5
P0-36	MAP2A	Target Setting of Mapping Parameter P0-26	0	-	○	○	○	4.3.5
P0-37	MAP3A	Target Setting of Mapping Parameter P0-27	0	-	○	○	○	4.3.5
P0-38	MAP4A	Target Setting of Mapping Parameter P0-28	0	-	○	○	○	4.3.5

7

Monitor and General Output Parameter								
Parameter	Abbr.	Function	Default	Unit	Control Mode			Related Section
					DMC	Sz	Tz	
P0-39	MAP5A	Target Setting of Mapping Parameter P0-29	0	-	O	O	O	4.3.5
P0-40	MAP6A	Target Setting of Mapping Parameter P0-30	0	-	O	O	O	4.3.5
P0-41	MAP7A	Target Setting of Mapping Parameter P0-31	0	-	O	O	O	4.3.5
P0-42	MAP8A	Target Setting of Mapping Parameter P0-32	0	-	O	O	O	4.3.5
P0-46★	SVSTS	Servo Digital Output Status Display	0	-	O	O	O	-

- (★) Read-only register, can only read the status. For example: P0-00, P0-10 and P4-00, etc.
- (▲) Setting is invalid when Servo On, e.g. P1-00, P1-46 and P2-33, etc.
- (●) Not effective until re-power on or off the servo drive, e.g. P1-01 and P3-00.
- (■) Parameters of no data retained setting, e.g. P2-31 and P3-06.

Filter and Resonance Suppression Parameter								
Parameter	Abbr.	Function	Default	Unit	Control Mode			Related Section
					DMC	Sz	Tz	
P1-06	SFLT	Acceleration / Deceleration Smooth Constant of Speed Command (Low-pass Filter)	0	ms		O		6.3.3
P1-07	TFLT	Smooth Constant of Torque Command (Low-pass Filter)	0	ms			O	6.4.3
P1-08	PFLT	Smooth Constant of Position Command (Low-pass Filter)	0	10 ms	O			6.2.4
P1-25	VSF1	Low-frequency Vibration Suppression (1)	1000	0.1 Hz	O			6.2.6
P1-26	VSG1	Low-frequency Vibration Suppression Gain (1)	0	-	O			6.2.6
P1-27	VSF2	Low-frequency Vibration Suppression (2)	1000	0.1 Hz	O			6.2.6
P1-28	VSG2	Low-frequency Vibration Suppression Gain (2)	0	-	O			6.2.6
P1-29	AVSM	Auto Low-frequency Vibration Suppression Setting	0	-	O			6.2.6
P1-30	VCL	Low-frequency Vibration Detection	500	pulse	O			6.2.6
P1-34	TACC	Acceleration Constant of S-Curve	200	ms	O	O		6.3.3
P1-35	TDEC	Deceleration Constant of S-Curve	200	ms	O	O		6.3.3
P1-36	TSL	Acceleration / Deceleration Constant of S-Curve	0	ms	O	O		6.3.3
P1-62	FRCL	Friction Compensation	0	%	O	O	O	-
P1-63	FRCT	Friction Compensation	1	ms	O	O	O	-
P1-68	PFLT2	Position Command Moving Filter	4	ms	O			-
P2-23	NCF1	Resonance Suppression (Notch Filter) (1)	1000	Hz	O	O	O	6.3.6

Filter and Resonance Suppression Parameter								
Parameter	Abbr.	Function	Default	Unit	Control Mode			Related Section
					DMC	Sz	Tz	
P2-24	DPH1	Resonance Suppression (Notch Filter) Attenuation Rate (1)	0	-dB	O	O	O	6.3.6
P2-43	NCF2	Resonance Suppression (Notch Filter) (2)	1000	Hz	O	O	O	6.3.6
P2-44	DPH2	Resonance Suppression (Notch Filter) Attenuation Rate (2)	0	-dB	O	O	O	6.3.6
P2-45	NCF3	Resonance Suppression (Notch Filter) (3)	1000	Hz	O	O	O	6.3.6
P2-46	DPH3	Resonance Suppression (Notch Filter) Attenuation Rate (3)	0	-dB	O	O	O	6.3.6
P2-47	ANCF	Auto Resonance Suppression Mode Setting	1	-	O	O	O	-
P2-48	ANCL	Resonance Suppression Detection Level	100	-	O	O	O	-
P2-25	NLP	Low-pass Filter of Resonance Suppression	0.2/0.5 (Panel / Software)	2/5 (Panel / Software)	O	O	O	6.3.6
			1 ms (Communi- cation)	0.1 ms (Communi- cation)				
P2-33▲	AUT3	Semi-auto Inertia Adjustment	0	-	O	O	O	-
P2-49	SJIT	Speed Detection Filter	0B	-	O	O	O	-

Gain and Switch Parameter								
Parameter	Abbr.	Function	Default	Unit	Control Mode			Related Section
					DMC	Sz	Tz	
P1-37	GDR	Inertia Ratio and Load Weight Ratio to Servo Motor	1.0 (Panel / Software)	1 times (Panel / Software)	O	O	O	-
			10 (Communi- cation)	0.1 times (Communi- cation)				
P2-00	KPP	Position Loop Gain	35	rad/s	O			6.2.5
P2-01	PPR	Switching Rate of Position Loop Gain	100	%	O			6.2.5
P2-02	PFG	Position Feed Forward Gain	50	%	O			6.2.5
P2-03	PFF	Smooth Constant of Position Feed Forward Gain	5	ms	O			-
P2-04	KVP	Speed Loop Gain	500	rad/s	O	O	O	6.3.5
P2-05	SPR	Switching Rate of Speed Loop Gain	100	%	O	O	O	-
P2-06	KVI	Speed Integral Compensation	100	rad/s	O	O	O	6.3.5
P2-07	KVF	Speed Feed Forward Gain	0	%	O	O	O	6.3.5
P2-26	DST	Anti-interference Gain	0	rad/s	O	O	O	-

7

Gain and Switch Parameter								
Parameter	Abbr.	Function	Default	Unit	Control Mode			Related Section
					DMC	Sz	Tz	
P2-27	GCC	Gain Switching and Switching Selection	0	-	O	O	O	-
P2-28	GUT	Gain Switching Time Constant	10	10 ms	O	O	O	-
P2-29	GPE	Gain Switching	1280000	pulse Kpps r/min	O	O	O	-
P2-31■	AUT1	Speed Loop Frequency Response Setting in Auto and Semi-auto Mode	40	Hz	O	O	O	5.6 6.3.5
P2-32▲	AUT2	Tuning Mode Selection	0	-	O	O	O	5.6 6.3.5
P2-53	KPI	Position Integral Compensation	0	rad/s	O	O	O	-

- (★) Read-only register, can only read the status. For example: P0-00, P0-10 and P4-00, etc.
- (▲) Setting is invalid when Servo On, e.g. P1-00, P1-46 and P2-33, etc.
- (●) Not effective until re-power on or off the servo drive, e.g. P1-01 and P3-00.
- (■) Parameters of no data retained setting, e.g. P2-31 and P3-06.

Position Control Parameter								
Parameter	Abbr.	Function	Default	Unit	Control Mode			Related Section
					DMC	Sz	Tz	
P1-01●	CTL	Input Setting of Control Mode and Control Command	0B	pulse r/min N-M	O	O	O	6.1 Table 7.1
P1-02▲	PSTL	Speed and Torque Limit Setting	0	-	O	O	O	-
P1-03	AOUT	Polarity Setting of Encoder Pulse Output	0	-	O	O	O	-
P1-12	TQ1	Internal Torque Limit 1	100	%	O	O		6.4.1
P1-13 ~ P1-14	TQ2 ~ 3	Internal Torque Limit 2 ~ 3	100	%		O		6.4.1
P1-44▲	GR1	Gear Ratio (Numerator) (N1)	128	pulse	O			6.2.3
P1-45▲	GR2	Gear Ratio (Denominator) (M)	10	pulse	O			6.2.3
P1-46▲	GR3	Pulse Number of Encoder Output	2500	pulse	O	O	O	-
P1-55	MSPD	Maximum Speed Limit	rated	r/min	O	O	O	-
P5-03	PDEC	Deceleration Time of Auto Protection	E0EFEFFF	-	O	O	O	-
P5-20 ~ P5-35	AC0 ~ AC15	Acceleration / Deceleration Time	200 ~ 30	ms	O			-
P5-08	SWLP	Forward Software Limit	+2 <sup>31</sup>	PUU	O			-
P5-09	SWLN	Reverse Software Limit	-2 <sup>31</sup>	PUU	O			-

Speed Control Parameter								
Parameter	Abbr.	Function	Default	Unit	Control Mode			Related Section
					DMC	Sz	Tz	
P1-01●	CTL	Input Setting of Control Mode and Control Command	0B	pulse r/min N-M	O	O	O	6.1 Table 7.1
P1-02▲	PSTL	Speed and Torque Limit Setting	0	-	O	O	O	Table 7.1
P1-03	AOUT	Polarity Setting of Encoder Pulse Output	0	-	O	O	O	-
P1-46▲	GR3	Pulse Number of Encoder Output	2500	pulse	O	O	O	-
P1-55	MSPD	Maximum Speed Limit	rated	r/min	O	O	O	-
P1-09 ~ P1-11	SP1~3	Internal Speed Command 1 ~ 3	1000 ~ 3000	0.1 r/min		O		6.3.1
P1-12	TQ1	Internal Torque Limit 1	100	%	O	O		-
P1-13 ~ P1-14	TQ2 ~ 3	Internal Torque Limit 2 ~ 3	100	%		O		
P1-76	AMSPD	Maximum Rotation Setting of Encoder Output (OA, OB)	5500	r/min	O	O	O	-

Torque Control Parameter								
Parameter	Abbr.	Function	Default	Unit	Control Mode			Related Section
					DMC	Sz	Tz	
P1-01●	CTL	Input Setting of Control Mode and Control Command	0B	pulse r/min N-M	O	O	O	6.1 Table 7.1
P1-02▲	PSTL	Speed and Torque Limit Setting	0	-	O	O	O	Table 7.1
P1-03	AOUT	Polarity Setting of Encoder Pulse Output	0	-	O	O	O	-
P1-46▲	GR3	Pulse Number of Encoder Output	2500	pulse	O	O	O	-
P1-55	MSPD	Maximum Speed Limit	rated	r/min	O	O	O	-
P1-09~ P1-11	SP1~3	Internal Speed Limit 1~3	100 ~ 300	r/min		O	O	-
P1-12~ P1-14	TQ1~3	Internal Torque Command 1~3	100	%	O			6.4.1

- (★) Read-only register, can only read the status. For example: P0-00, P0-10 and P4-00, etc.
- (▲) Setting is invalid when Servo On, e.g. P1-00, P1-46 and P2-33, etc.
- (●) Not effective until re-power on or off the servo drive, e.g. P1-01 and P3-00.
- (■) Parameters of no data retained setting, e.g. P2-31 and P3-06.

### Planning of Digital Input / Output Pin and Output Setting Parameter

Parameter	Abbr.	Function	Default	Unit	Control Mode			Related Section
					DMC	Sz	Tz	
P0-53	ZDRT	General Range Compare Digital Output - Filtering Time	0	ms	O	O	O	-
P0-54	ZON1L	General Range Compare Digital Output - Lower Limit of 1 <sup>st</sup> Monitoring Variable	0	-	O	O	O	-
P0-55	ZON1H	General Range Compare Digital Output - Upper Limit of 1 <sup>st</sup> Monitoring Variable	0	-	O	O	O	-
P2-09	DRT	DI Debouncing Time	2	ms	O	O	O	-
P2-10	DI1	DI1 Functional Planning	101	-	O	O	O	Table 7.1
P2-11	DI2	DI2 Functional Planning	104	-	O	O	O	Table 7.1
P2-12	DI3	DI3 Functional Planning	022	-	O	O	O	Table 7.1
P2-13	DI4	DI4 Functional Planning	023	-	O	O	O	Table 7.1
P2-14	DI5	DI5 Functional Planning	021	-	O	O	O	Table 7.1
P2-18	DO1	DO1 Functional Planning	101	-	O	O	O	Table 7.2
P2-19	DO2	DO2 Functional Planning	103	-	O	O	O	Table 7.2
P1-38	ZSPD	Zero Speed Range Setting	10.0 (Panel / Software)	1 r/min (Panel / Software)	O	O	O	Table 7.2
			100 (Communication)	0.1 r/min (Communication)				
P1-39	SSPD	Target Speed Detection Level	3000	r/min	O	O	O	Table 7.2
P1-42	MBT1	Enable Delay Time of Brake	0	ms	O	O	O	6.5
P1-43	MBT2	Disable Delay Time of Brake	0	ms	O	O	O	6.5
P1-47	SCPD	Speed Reached (DO.SP_OK) Range	10	r/min		O		-
P1-54	PER	Position Completed Range	12800	pulse	O			Table 7.2
P1-56	OVW	Output Overload Warning Level	120	%	O	O	O	-

### Communication Parameter

Parameter	Abbr.	Function	Default	Unit	Control Mode			Related Section
					DMC	Sz	Tz	
P3-00●	ADR	Address Setting	01	-	O	O	O	-
P3-01	BRT	Transmission Speed	3203	bps	O	O	O	-
P3-02	PTL	Communication Protocol	6	-	O	O	O	-
P3-03	FLT	Communication Error Disposal	0	-	O	O	O	-
P3-04	CWD	Communication Timeout	0	sec	O	O	O	-

P3-05	CMM	Communication Mechanism	0	-	O	O	O	-
P3-06■	SDI	Control Switch of Digital Input (DI)	0	-	O	O	O	-
P3-07	CDT	Communication Response Delay Time	0	0.5 ms	O	O	O	-
P3-08	MNS	Monitor Mode	0	-	O	O	O	-
P3-09	SYC	DMCNET Synchronize Setting	3511	-	O			-
P3-10	CANEN	DMCNET Protocol Setting	1	-	O			-
P3-11	CANOP	DMCNET Selection	0	-	O			-
P3-12	QSTPO	DMCNET Support Setting	0	-	O			-

(★) Read-only register, can only read the status. For example: P0-00, P0-10 and P4-00, etc.

(▲) Setting is invalid when Servo On, e.g. P1-00, P1-46 and P2-33, etc.

(●) Not effective until re-power on or off the servo drive, e.g. P1-01 and P3-00.

(■) Parameters of no data retained setting, e.g. P2-31 and P3-06.

Diagnosis Parameter								
Parameter	Abbr.	Function	Default	Unit	Control Mode			Related Section
					DMC	Sz	Tz	
P4-00★	ASH1	Fault Record (N)	0	-	O	O	O	4.4.1
P4-01★	ASH2	Fault Record (N-1)	0	-	O	O	O	4.4.1
P4-02★	ASH3	Fault Record (N-2)	0	-	O	O	O	4.4.1
P4-03★	ASH4	Fault Record (N-3)	0	-	O	O	O	4.4.1
P4-04★	ASH5	Fault Record (N-4)	0	-	O	O	O	4.4.1
P4-05	JOG	Servo Motor Jog Control	20	r/min	O	O	O	4.4.2
P4-06▲■	FOT	Digital Output Register (Readable and Writable)	0	-	O	O	O	4.4.3
P4-07	ITST	Multi-function of Digital Input	0	-	O	O	O	4.4.4 8.2
P4-08★	PKEY	Input Status of the Drive Keypad (Read-only)	-	-	O	O	O	-
P4-09★	MOT	Digital Output Status (Read-only)	-	-	O	O	O	4.4.5
P4-10▲	CEN	Adjustment Selection	0	-	O	O	O	-
P4-15	COF1	Current Detector (V1 Phase) Offset Adjustment	Factory Setting	-	O	O	O	-
P4-16	COF2	Current Detector (V2 Phase) Offset Adjustment	Factory Setting	-	O	O	O	-
P4-17	COF3	Current Detector (W1 Phase) Offset Adjustment	Factory Setting	-	O	O	O	-
P4-18	COF4	Current Detector (W2 Phase) Offset Adjustment	Factory Setting	-	O	O	O	-
P4-19	TIGB	IGBT NTC Adjustment Detection Level (cannot reset)	Factory Setting	-	O	O	O	-

## 7.3 Parameter Description

### P0-xx Monitor Parameters

P0-00★	VER	Firmware Version	Address: 0000H 0001H
Operational Interface:	Panel / Software	Communication	Related Section: -
Default:	Factory Setting		Control Mode: ALL
Unit:	-		Range: -
Format:	DEC		Data Size: 16-bit

Settings:

This parameter shows the firmware version of the servo drive.

P0-01■	ALE	Alarm Code Display of Drive (Seven-segment Display)	Address: 0002H 0003H
Operational Interface:	Panel / Software	Communication	Related Section: 9.1, 9.2, 9.3
Default:	-		Control Mode: ALL
Unit:	-		Range: 0x0000 ~ 0xFFFF: Set P0-01 to 0 to clear the alarm (Same as DI.ARST).
Format:	HEX		Data Size: 16-bit

Settings:

Alarm of Servo Drive			
Code	Description	Code	Description
001	Over current	016	IGBT overheat
002	Over voltage	017	Abnormal EEPROM
003	Under voltage (In default setting, the alarm occurs only when the voltage is not enough in Servo On status. In Servo On status, after the servo drive has been connected to R,S,T power, the alarm will not be cleared automatically, please refer to P2-66)	018	Abnormal signal output
004	Motor combination error (The drive corresponds to the wrong motor)	019	Serial communication error
005	Regeneration error	020	Serial communication timeout
006	Overload	021	Reserved
007	Over speed	022	Main circuit power lack phase
008	Abnormal pulse command	023	Early warning for overload
009	Excessive deviation	024	Encoder initial magnetic field error (The magnetic field of the encoder U, V, W signal is in error)
010	Reserved	025	The internal of the encoder is in error (The internal memory and the internal counter are in error)
011	Encoder error (The servo drive cannot communicate with the encoder due to disconnection or wrong wiring)	026	Unreliable internal data of the encoder
012	Adjustment error	027	Encoder reset error
013	Emergency stop	028	The encoder is over voltage or the internal of the encoder is in error
014	Reverse limit error	029	Gray code error
015	Forward limit error	030	Motor crash error

Alarm of Servo Drive			
Code	Description	Code	Description
031	Incorrect wiring of the motor power cable U, V, W (Incorrect wiring of motor power cable U, V, W, GND)	061	Encoder under voltage
034	Internal communication of the encoder is in error	062	The multiturn of absolute encoder overflows
044	Warning of servo drive function overload	069	Wrong motor type
060	The absolute position is lost	099	DSP firmware upgrade

Alarm of DMCNET Communication	
Code	Description
185	Abnormal DMCNET Bus hardware

Alarm of Motion Control			
Code	Description	Code	Description
201	An error occurs when loading DMCNET data	301	DMCNET fails to synchronize
283	Forward software limit	302	The synchronized signal of DMCNET is sent too fast
285	Reverse software limit	303	The synchronized signal of DMCNET is sent too slow
289	Feedback Position counter overflows	304	DMCNET IP command fails

P0-02	STS	Drive Status	Address: 0004H 0005H
Operational Interface:	Panel / Software	Communication	Related Section: -
Default:	00		Control Mode: ALL
Unit:	-		Range: 00 ~ 127
Format:	DEC		Data Size: 16-bit

Settings:

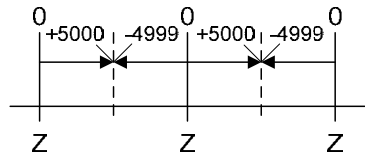
01	Motor feedback pulse number (after the scaling of electronic gear ratio) (PUU) [User unit]	17	The frequency of resonance suppression
02	Deviation between control command pulse and feedback pulse number (PUU) [User unit]	8	The distance from the current position to Z. The range of the value is between -5000 and +5000; 
03	The number of motor feedback pulse (Encoder unit) (1,280,000 pulse/rev) [pulse]	19	Mapping parameter#1: P0 - 25
04	Distance to command terminal (Encoder unit) [Pulse]	20	Mapping parameter#2: P0 - 26
05	Error pulse number (after the scaling of electronic gear ratio) (Encoder unit) [Pulse]	21	Mapping parameter#3: P0 - 27
06	The frequency of pulse command input [Kpps]	22	Mapping parameter#4: P0 - 28
07	Motor speed [r/min]	23	Monitoring variable#1: P0 - 09
08	Speed command input [Volt]	24	Monitoring variable#2: P0 - 10
09	Speed command input [r/min]	25	Monitoring variable#3: P0 - 11
10	Torque command input [Volt]	26	Monitoring variable#4: P0 - 12
11	Torque command input [%]	38	It displays the battery voltage [0.1 Volt]. For example, if it displays 36, it means the battery voltage is 3.6 V.
12	Average torque [%]		
13	Peak torque [%]		
14	Main circuit voltage (BUS voltage) [Volt]		
15	Load / motor inertia ratio [0.1 times]		
16	IGBT temperature		

7

<b>P0-03~P0-07</b>	Reserved		
--------------------	----------	--	--

<b>P0-08★</b>	<b>TSON</b>	<b>Power On Time</b>		<b>Address: 0010H 0011H</b>
Operational Interface:	Panel / Software	Communication	Related Section:	-
Default:	0		Control Mode:	-
Unit:	Hour		Range:	0 ~ 65535
Format:	DEC		Data Size:	16-bit

Settings:  
It shows the total start up time of the servo drive.

<b>P0-09★</b>	<b>CM1</b>	<b>Status Monitor Register 1</b>		<b>Address: 0012H 0013H</b>
Operational Interface:	Panel / Software	Communication	Related Section:	4.3.5
Default:	-		Control Mode:	ALL
Unit:	-		Range:	-
Format:	DEC		Data Size:	32-bit

Settings:  
The setting value which is set by P0-17 should be monitored via P0-09. (Please refer to P0-02). Users need to access the address via communication port to read the status.  
For example:  
If P0-17 is set to 3, when accessing P0-09, it obtains the total feedback pulse number of motor encoder. For MODBUS communication, two 16-bit data, 0012H and 0013H will be read as one 32-bit data; (0013H:0012H) = (Hi-word:Low-word) Set P0-02 to 23. The panel displays "VAR-1" first, and then shows the content of P0-09.

<b>P0-10★</b>	<b>CM2</b>	<b>Status Monitor Register 2</b>		<b>Address: 0014H 0015H</b>
Operational Interface:	Panel / Software	Communication	Related Section:	4.3.5
Default:	-		Control Mode:	ALL
Unit:	-		Range:	-
Format:	DEC		Data Size:	32-bit

Settings:  
The setting value which is set by P0-18 should be monitored via P0-10. (Please refer to P0-02) Users need to access the address via communication port to read the status. Set P0-02 to 24. The panel displays "VAR-2" first, and then shows the content of P0-10.

<b>P0-11★</b>	<b>CM3</b>	<b>Status Monitor Register 3</b>		<b>Address: 0016H 0017H</b>
Operational Interface:	Panel / Software	Communication	Related Section:	4.3.5
Default:	-		Control Mode:	ALL
Unit:	-		Range:	-
Format:	DEC		Data Size:	32-bit

Settings:  
The setting value which is set by P0-19 should be monitored via P0-11. (Please refer to P0-02) Users need to access the address via communication port to read the status. Set P0-02 to 25. The panel displays "VAR-3" first, and then shows the content of P0-11.

<b>P0-12★</b>	<b>CM4</b>	<b>Status Monitor Register 4</b>		<b>Address: 0018H 0019H</b>
Operational Interface:	Panel / Software	Communication	Related Section:	3.3.5
Default:	-		Control Mode:	ALL
Unit:	-		Range:	-
Format:	DEC		Data Size:	32-bit

Settings:

The setting value which is set by P0-20 should be monitored via P0-12. (Please refer to P0-02)  
 Users need to access the address via communication port to read the status. Set P0-02 to 26. The panel displays "VAR-4" first, and then shows the content of P0-12.

P0-13★	CM5	Status Monitor Register 5		Address: 001AH 001BH
Operational Interface:	Panel / Software	Communication	Related Section:	4.3.5
Default:	-		Control Mode:	ALL
Unit:	-		Range:	-
Format:	DEC		Data Size:	32-bit

Settings:  
 The setting value which is set by P0-21 should be monitored via P0-13. (Please refer to P0-02)  
 Users need to access the address via communication port to read the status.

<b>P0-14~P0-16</b>	<b>Reserved</b>			
--------------------	-----------------	--	--	--

P0-17	CM1A	Status Monitor Register 1 Selection		Address: 0022H 0023H
Operational Interface:	Panel / Software	Communication	Related Section:	-
Default:	0		Control Mode:	-
Unit:	-		Range:	0 ~ 127
Format:	DEC		Data Size:	16-bit

Settings:  
 Please refer to the description of P0-02 for setting value.  
 For example:  
 If P0-17 is set to 07, then reading P0-09 means reading "Motor Speed (r / min)".

P0-18	CM2A	Status Monitor Register 2 Selection		Address: 0024H 0025H
Operational Interface:	Panel / Software	Communication	Related Section:	-
Default:	0		Control Mode:	-
Unit:	-		Range:	0 ~ 127
Format:	DEC		Data Size:	16-bit

Settings:  
 Please refer to the description of P0-02 for the setting value.

P0-19	CM3A	Status Monitor Register 3 Selection		Address: 0026H 0027H
Operational Interface:	Panel / Software	Communication	Related Section:	-
Default:	0		Control Mode:	-
Unit:	-		Range:	0 ~ 127
Format:	DEC		Data Size:	16-bit

Settings:  
 Please refer to the description of P0-02 for the setting value.

P0-20	CM4A	Status Monitor Register 4 Selection		Address: 0028H 0029H
Operational Interface:	Panel / Software	Communication	Related Section:	-
Default:	0		Control Mode:	-
Unit:	-		Range:	0 ~ 127
Format:	DEC		Data Size:	16-bit

Settings:  
 Please refer to the description of P0-02 for the setting value.

7

P0-21	CM5A	Status Monitor Register 5 Selection		Address: 002AH 002BH
Operational Interface:	Panel / Software	Communication	Related Section:	-
Default:	0		Control Mode:	-
Unit:	-		Range:	0 ~ 127
Format:	DEC		Data Size:	16-bit

Settings:

Please refer to the description of P0-02 for the setting value.

P0-22~P0-24	Reserved

P0-25	MAP1	Mapping Parameter# 1		Address: 0032H 0033H
Operational Interface:	Panel / Software	Communication	Related Section:	4.3.5
Default:	No need to initialize		Control Mode:	ALL
Unit:	-		Range:	Determined by the corresponding parameter of P0-35
Format:	HEX		Data Size:	32-bit

Settings:

Users can continuously read and write parameters that are not in the same group. The content of the parameter that is specified by P0-35 will be shown in P0-25. Please refer to the description of P0-35 for parameter setting.

P0-26	MAP2	Mapping Parameter# 2		Address: 0034H 0035H
Operational Interface:	Panel / Software	Communication	Related Section:	4.3.5
Default:	No need to initialize		Control Mode:	ALL
Unit:	-		Range:	Determined by the corresponding parameter of P0-36
Format:	HEX		Data Size:	32-bit

Settings:

The using method is the same as P0-25. The mapping target is set by parameter P0-36.

P0-27	MAP3	Mapping Parameter# 3		Address: 0036H 0037H
Operational Interface:	Panel / Software	Communication	Related Section:	4.3.5
Default:	No need to initialize		Control Mode:	ALL
Unit:	-		Range:	Determined by the corresponding parameter of P0-37
Format:	HEX		Data Size:	32-bit

Settings:

The using method is the same as P0-25. The mapping target is set by parameter P0-37.

P0-28	MAP4	Mapping Parameter# 4		Address: 0038H 0039H
Operational Interface:	Panel / Software	Communication	Related Section:	4.3.5
Default:	No need to initialize		Control Mode:	ALL
Unit:	-		Range:	Determined by the corresponding parameter of P0-38
Format:	HEX		Data Size:	32-bit

Settings:

The using method is the same as P0-25. The mapping target is set by parameter P0-38.

<b>P0-29</b>	<b>MAP5</b>	<b>Mapping Parameter# 5</b>		<b>Address: 003AH 003BH</b>
Operational Interface:	Panel / Software	Communication	Related Section:	4.3.5
Default:	No need to initialize		Control Mode:	ALL
Unit:	-		Range:	Determined by the corresponding parameter of P0-39
Format:	HEX		Data Size:	32-bit

Settings:

The using method is the same as P0-25. The mapping target is set by parameter P0-39.

<b>P0-30</b>	<b>MAP6</b>	<b>Mapping Parameter# 6</b>		<b>Address: 003CH 003DH</b>
Operational Interface:	Panel / Software	Communication	Related Section:	4.3.5
Default:	No need to initialize		Control Mode:	ALL
Unit:	-		Range:	Determined by the corresponding parameter of P0-40
Format:	HEX		Data Size:	32-bit

Settings:

The using method is the same as P0-25. The mapping target is set by parameter P0-40.

<b>P0-31</b>	<b>MAP7</b>	<b>Mapping Parameter# 7</b>		<b>Address: 003EH 003FH</b>
Operational Interface:	Panel / Software	Communication	Related Section:	4.3.5
Default:	No need to initialize		Control Mode:	ALL
Unit:	-		Range:	Determined by the corresponding parameter of P0-41
Format:	HEX		Data Size:	32-bit

Settings:

The using method is the same as P0-25. The mapping target is set by parameter P0-41.

<b>P0-32</b>	<b>MAP8</b>	<b>Mapping Parameter# 8</b>		<b>Address: 0040H 0041H</b>
Operational Interface:	Panel / Software	Communication	Related Section:	4.3.5
Default:	No need to initialize		Control Mode:	ALL
Unit:	-		Range:	Determined by the corresponding parameter of P0-42
Format:	HEX		Data Size:	32-bit

Settings:

The using method is the same as P0-25. The mapping target is set by parameter P0-42.

<b>P0-33-P0-34</b>	<b>Reserved</b>
--------------------	-----------------

<b>P0-35</b>	<b>MAP1A</b>	<b>Target Setting of Mapping Parameter P0-25</b>		<b>Address: 0046H 0047H</b>
Operational Interface:	Panel / Software	Communication	Related Section:	4.3.5
Default:	0		Control Mode:	ALL
Unit:	-		Range:	Determined by the communication address of the parameter group
Format:	HEX		Data Size:	32-bit

Settings:

Select the data block to access the parameter corresponded by register 1. The mapping content is 32 bits wide and can map to two 16-bit parameters or one 32-bit parameter.

# 7

P0-35:

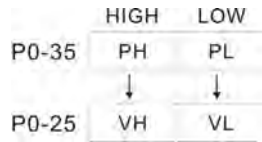

Mapping parameter: P0-35; Mapping content: P0-25

When PH≠PL, it means the content of P0-25 includes two 16-bit parameters.

VH=\*(PH), VL=\*(PL)

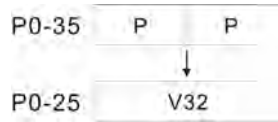

Mapping parameter: P0-35; Mapping content: P0-25

When PH=PL=P, it means the content of P0-25 includes one 32-bit parameter.

V32=\*(P) If P=060Ah (P6-10), then V32 is P6-10.

The setting format of PH, PL is:

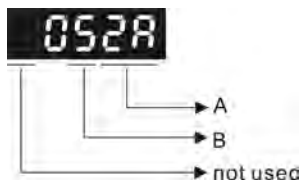

A: parameter indexing (hexadecimal)  
B: parameter group (hexadecimal)

For example:

If the mapping target is P2-06, set P0-35 to 0206.

If the mapping target is P5-42, set P0-35 to 052A.

For example:

If users desire to read / write P1-44 (32-bit) through P0-25, set P0-35 to 0x012C012C via panel or communication. Then, when reading / writing P0-25, it also reads / writes P1-44.

Moreover, users can also access the value of P2-02 and P2-04 through P0-25.

P2-02 Position feed forward gain (16-bit)

P2-04 Speed control gain (16-bit)

Users only need to set P0-35 to 0x02040202. Then, when reading / writing P0-25, it also reads / writes the value of P2-02 and P2-04.

P0-36	MAP2A	Target Setting of Mapping Parameter P0-26		Address: 0048H 0049H
Operational Interface:	Panel / Software	Communication	Related Section:	4.3.5
Default:	0		Control Mode:	ALL
Unit:	-		Range:	Determined by the communication address of the parameter group
Format:	HEX		Data Size:	32-bit

Settings:

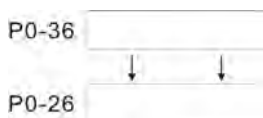

P0-37	MAP3A	Target Setting of Mapping Parameter P0-27		Address: 004AH 004BH
Operational Interface:	Panel / Software	Communication	Related Section:	4.3.5
Default:	0		Control Mode:	ALL
Unit:	-		Range:	Determined by the communication address of the parameter group
Format:	HEX		Data Size:	32-bit

Settings:

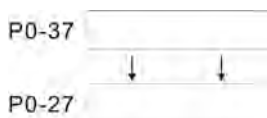

P0-38	MAP4A	Target Setting of Mapping Parameter P0-28		Address: 004CH 004DH
Operational Interface:	Panel / Software	Communication	Related Section:	4.3.5
Default:	0		Control Mode:	ALL
Unit:	-		Range:	Determined by the communication address of the parameter group
Format:	HEX		Data Size:	32-bit

Settings:

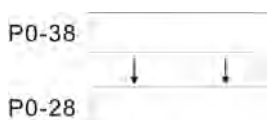

P0-39	MAP5A	Target Setting of Mapping Parameter P0-29		Address: 004EH 004FH
Operational Interface:	Panel / Software	Communication	Related Section:	4.3.5
Default:	0		Control Mode:	ALL
Unit:	-		Range:	Determined by the communication address of the parameter group
Format:	HEX		Data Size:	32-bit

Settings:

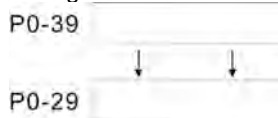

P0-40	MAP6A	Target Setting of Mapping Parameter P0-30		Address: 0050H 0051H
Operational Interface:	Panel / Software	Communication	Related Section:	4.3.5
Default:	0		Control Mode:	ALL
Unit:	-		Range:	Determined by the communication address of the parameter group
Format:	HEX		Data Size:	32-bit

Settings:

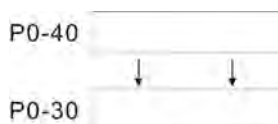

P0-41	MAP7A	Target Setting of Mapping Parameter P0-31		Address: 0052H 0053H
Operational Interface:	Panel / Software	Communication	Related Section:	4.3.5
Default:	0		Control Mode:	ALL
Unit:	-		Range:	Determined by the communication address of the parameter group
Format:	HEX		Data Size:	32-bit

Settings:

7

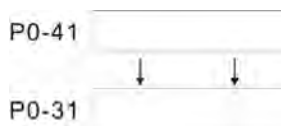

P0-42	MAP8A	Target Setting of Mapping Parameter P0-32		Address: 0054H 0055H
Operational Interface:	Panel / Software	Communication	Related Section:	4.3.5
Default:	0		Control Mode:	ALL
Unit:	-		Range:	Determined by the communication address of the parameter group
Format:	HEX		Data Size:	32-bit

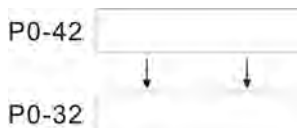

P0-43	Reserved			
-------	----------	--	--	--

P0-44★	PCMN	Status Monitor Register (for PC software)		Address: 0058H 0059H
Operational Interface:	Panel / Software	Communication	Related Section:	4.3.5
Default:	0		Control Mode:	ALL
Unit:	-		Range:	Determined by the communication address of the parameter group
Format:	DEC		Data Size:	32-bit

Settings:  
Same as parameter P0-09.

P0-45■	PCMNA	Status Monitor Register Selection (for PC software)		Address: 005AH 005BH
Operational Interface:	Panel / Software	Communication	Related Section:	4.3.5
Default:	0		Control Mode:	ALL
Unit:	-		Range:	0 ~ 127
Format:	DEC		Data Size:	16-bit

Settings:  
Same as parameter P0-17.

P0-46★	SVSTS	Servo Digital Output Status Display		Address: 005CH 005DH
Operational Interface:	Panel / Software	Communication	Related Section:	-
Default:	0		Control Mode:	ALL
Unit:	-		Range:	0x00 ~ 0xFF
Format:	HEX		Data Size:	16-bit

Settings:

Bit	Function	Bit	Function
0	SRDY (Servo is ready)	4	TPOS (Target position completed)
1	SON (Servo On)	5	TQL (Torque limiting)
2	ZSPD (Zero speed detection)	6	ALRM (Servo alarm)
3	TSPD (Target speed reached)	7	BRKR (Brake control output)

Bit	Function	Bit	Function
8	HOME (Homing finished)	12	Reserved
9	OLW (Early warning for overload)	13	Reserved
10	WARN (When servo warning, CW, CCW, EMGS, under voltage or communication error occurs, DO is ON)	14	Reserved
11	Reserved	15	Reserved

P0-49■	UAP	Renew Encoder Absolute Position	Address: 0062H 0063H
Operational Interface:	Panel / Software	Communication	Related Section: -
Default:	0		Control Mode: ALL
Unit:	-		Range: 0x00 ~ 0x02
Format:	HEX	Data Size:	16-bit

Settings:



Parameter renew setting:

- 1: Renew the encoder data to parameters P0-50 ~ P0-52 only.
- 2: Renew parameters P0-50 ~ P0-52 and clear the position error as well. When this setting is activated, the current position of the motor will be reset as the target position of position command.

P0-50★	APSTS	Absolute Coordinate System Status	Address: 0064H 0065H
Operational Interface:	Panel / Software	Communication	Related Section: -
Default:	0		Control Mode: ALL
Unit:	-		Range: 0x00 ~ 0x1F
Format:	HEX	Data Size:	16-bit

Settings:

Bit 7	Bit 6	Bit 5	Bit 4	Bit 3	Bit 2	Bit 1	Bit 0
-------	-------	-------	-------	-------	-------	-------	-------

Bit 15	Bit 14	Bit 13	Bit 12	Bit 11	Bit 10	Bit 9	Bit 8
--------	--------	--------	--------	--------	--------	-------	-------

- Bit 0: 1 means absolute position is lost; 0 means normal.
- Bit 1: 1 means low battery; 0 means normal.
- Bit 2: 1 means multiturn overflows; 0 means normal.
- Bit 3: 1 means PUU overflows; 0 means normal.
- Bit 4: 1 means the absolute coordinate system has not been set yet; 0 means normal.
- Bit 5~ Bit 15: Reserved (0).

P0-51★	APR	Encoder Absolute Position (Multiturn)	Address: 0066H 0067H
Operational Interface:	Panel / Software	Communication	Related Section: -
Default:	0		Control Mode: ALL
Unit:	rev	Range:	-32768 ~ +32767
Format:	DEC	Data Size:	32-bit

Settings:

When Bit 1 of P2-70 is set to read the encoder pulse number, this parameter represents the turns of encoder absolute position. When Bit 1 of P2-70 is set to read the PUU number, this parameter will be disabled and the value of this parameter is 0.

7

P0-52★	APP	Encoder Absolute Position (Pulse number within single turn or PUU)		Address: 0068H 0069H
Operational Interface:	Panel / Software	Communication	Related Section:	-
Default:	0		Control Mode:	ALL
Unit:	Pulse or PUU		Range:	0 ~ 1280000-1 (pulse number) -2147483648 ~ 2147483647 (PUU)
Format:	DEC		Data Size:	32-bit

Settings:

When Bit 1 of P2-70 is set to read the pulse number, this parameter represents the pulse number of encoder absolute position. When Bit 1 of P2-70 is set to read the PUU number, this parameter represents the PUU number of motor absolute position.

P0-53	ZDRT	General Range Compare Digital Output - Filtering Time		Address: 006AH 006BH
Operational Interface:	Panel / Software	Communication	Related Section:	-
Default:	0		Control Mode:	ALL
Unit:	ms		Range:	0x0000 ~ 0x000F
Format:	HEX		Data Size:	16-bit

Settings:

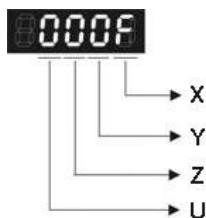

X: Filtering time for the 1<sup>st</sup> monitoring variable  
 UYZ: Reserved  
 When the value of the monitoring variable is within the setting value of P0-54 and P0-55, the value will not be outputted until the filtering time set by P0-53 is reached.

For example: when P0-09 is used.

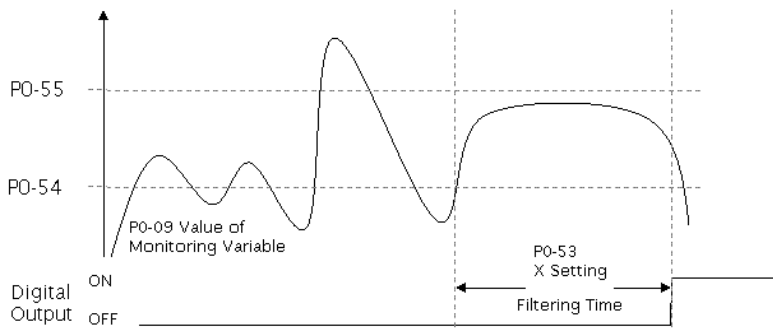

P0-54	ZON1L	General Range Compare Digital Output - Lower Limit of 1 <sup>st</sup> Monitoring Variable		Address: 006CH 006DH
Operational Interface:	Panel / Software	Communication	Related Section:	-
Default:	0		Control Mode:	ALL
Unit:	-		Range:	-2147483648 ~ +2147483647
Format:	DEC		Data Size:	32-bit

Settings:

If the value of parameter P0-09 changes within the range set by P0-54 and P0-55, its value will be outputted after the filtering time determined by parameter P0-53.X.

P0-55	ZON1H	General Range Compare Digital Output - Upper Limit of 1 <sup>st</sup> Monitoring Variable		Address: 006EH 006FH
Operational Interface:	Panel / Software	Communication	Related Section:	-
Default:	0		Control Mode:	ALL
Unit:	-		Range:	-2147483648 ~ +2147483647
Format:	DEC		Data Size:	32-bit

Settings:

If the value of parameter P0-09 changes within the range set by P0-54 and P0-55, its value will be outputted after the filtering time determined by parameter P0-53.X.

<b>P0-56~P0-61</b>	<b>Reserved</b>
--------------------	-----------------

7

7

P1-xx Basic Parameters

P1-00▲	Reserved		
--------	----------	--	--

P1-01●	CTL	Input Setting of Control Mode and Control Command	Address: 0102H 0103H
Operational Interface:	Panel / Software	Communication	Related Section: 6.1, Table 7.1
Default:	0B		Control Mode: ALL
Unit:	P (pulse); S (r/min); T (N-M)		Range: 00 ~ 110F
Format:	HEX		Data Size: 16-bit

Settings:

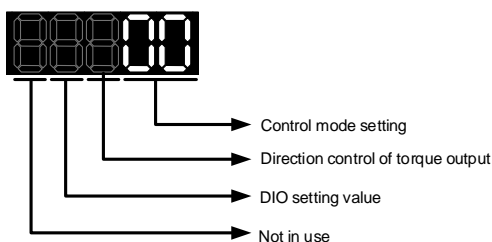

• Control Mode Setting

Mode	Sz	Tz
04	▲	
05		▲
0B	DMCNET Mode	

Sz: Speed Control Mode (Zero Speed / Internal Speed Command. It can be selected via DI.SPD0 and DI.SPD1)

Tz: Torque Control Mode (Zero Speed / Internal Speed Command. It can be selected via DI.TCM0 and DI.TCM1)

• Torque Output Direction Setting

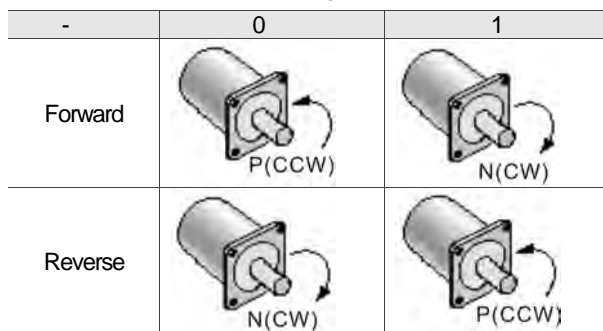

• DIO Setting

- 0: When switching mode, DIO (P2-10 ~ P2-22) remains its original setting and will not be changed.
- 1: When switching mode, DIO (P2-10 ~ P2-22) can be reset to the default value of each operational mode automatically.

P1-02▲	PSTL	Speed and Torque Limit Setting		Address: 0104H 0105H
Operational Interface:	Panel / Software	Communication	Related Section:	Table 7.1
Default:	0		Control Mode:	ALL
Unit:	-		Range:	00 ~ 11
Format:	HEX		Data Size:	16-bit

Settings:

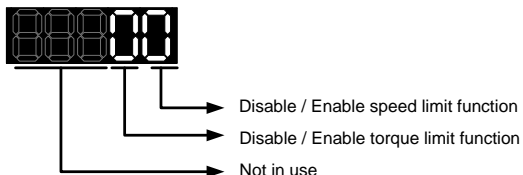

- Disable / Enable speed limit function  
 0: Disable speed limit function  
 1: Enable speed limit function (It is effective in Tz mode only)  
 Other: Reserved  
 Block diagram of speed limit setting:

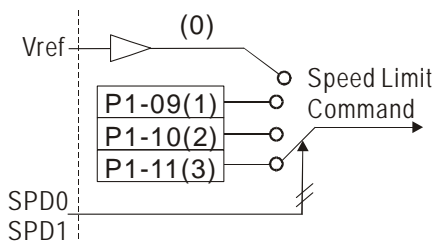

- Disable / Enable torque limit function  
 0: Disable torque limit function  
 1: Enable torque limit function (It is effective in DMCNET / Sz mode)  
 Other: Reserved  
 Block diagram of torque limit setting:

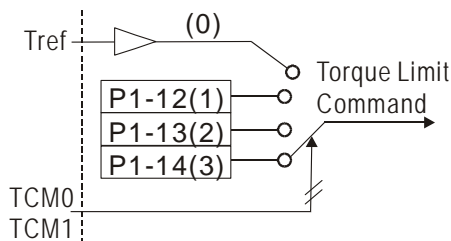

P1-03	AOUT	Polarity Setting of Encoder Pulse Output		Address: 0106H 0107H
Operational Interface:	Panel / Software	Communication	Related Section:	-
Default:	0		Control Mode:	ALL
Unit:	-		Range:	0 ~ 13
Format:	HEX		Data Size:	16-bit

Settings:

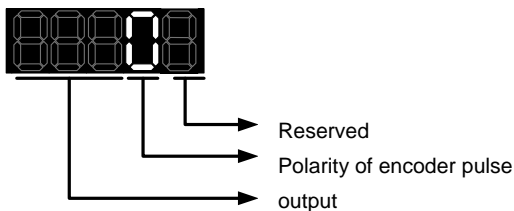

- Polarity of encoder pulse output  
 0: Forward output  
 1: Reverse output

P1-04-P1-05	Reserved
-------------	----------

7

P1-06	SFLT	Acceleration / Deceleration Smooth Constant of Speed Command (Low-pass Filter)		Address: 010CH 010DH
Operational Interface:	Panel / Software	Communication	Related Section:	6.3.3
Default:	0		Control Mode:	Sz
Unit:	ms		Range:	0 ~ 1000
Format:	DEC		Data Size:	16-bit
Settings: 0: Disabled				

P1-07	TFLT	Smooth Constant of Torque Command (Low-pass Filter)		Address: 010EH 010FH
Operational Interface:	Panel / Software	Communication	Related Section:	6.4.3
Default:	0		Control Mode:	Tz
Unit:	ms		Range:	0 ~ 1000
Format:	DEC		Data Size:	16-bit
Settings: 0: Disabled				

P1-08	PFLT	Smooth Constant of Position Command (Low-pass Filter)		Address: 0110H 0111H
Operational Interface:	Panel / Software	Communication	Related Section:	6.2.4
Default:	0		Control Mode:	DMCNET
Unit:	10 ms		Range:	0 ~ 1000
Format:	DEC		Data Size:	16-bit
Example:	11 = 110 ms			
Settings: 0: Disabled				

P1-09	SP1	Internal Speed Command 1 / Internal Speed Limit 1		Address: 0112H 0113H
Operational Interface:	Panel / Software	Communication	Related Section:	6.3.1
Default:	1000		Control Mode:	Sz (Internal Speed Command) / Tz (Internal Speed Limit)
Unit:	0.1 r/min		Range:	-60000 ~ +60000
Format:	DEC		Data Size:	32-bit
Example:	Internal Speed Command: 120 = 12 r/min Internal Speed Limit: Positive value and negative value are the same. Please refer to the following description.			
Settings: Internal Speed Command 1: The setting of the 1 <sup>st</sup> internal speed command Internal Speed Limit 1: The setting of the 1 <sup>st</sup> internal speed limit Example of inputting internal speed limit:				

Speed Limit Setting Value of P1-09	Allowable Speed Range	Forward Speed Limit	Reverse Speed Limit
1000	-100 ~ 100 r/min	100 r/min	-100 r/min
-1000			

P1-10	SP2	Internal Speed Command 2 / Internal Speed Limit 2		Address: 0114H 0115H
Operational Interface:	Panel / Software	Communication	Related Section:	6.3.1
Default:	2000		Control Mode:	Sz (Internal Speed Command) / Tz (Internal Speed Limit)
Unit:	0.1 r/min		Range:	-60000 ~ +60000
Format:	DEC		Data Size:	32-bit
Example:	Internal Speed Command: 120 = 12 r/min Internal Speed Limit: Positive value and negative value are the same. Please refer to the following description.			

Settings:

Internal Speed Command 2: The setting of the 2<sup>nd</sup> internal speed command

Internal Speed Limit 2: The setting of the 2<sup>nd</sup> internal speed limit

Example of inputting internal speed limit:

Speed Limit Setting Value of P1-10	Allowable Speed Range	Forward Speed Limit	Reverse Speed Limit
1000	-100 ~ 100 r/min	100 r/min	-100 r/min
-1000			

P1-11	SP3	Internal Speed Command 3 / Internal Speed Limit 3		Address: 0116H 0117H
Operational Interface:	Panel / Software	Communication	Related Section:	6.3.1
Default:	3000		Control Mode:	Sz (Internal Speed Command) / Tz (Internal Speed Limit)
Unit:	0.1 r/min		Range:	-60000 ~ +60000
Format:	DEC		Data Size:	32-bit
Example:	Internal Speed Command: 120 = 12 r/min Internal Speed Limit: Positive value and negative value are the same. Please refer to the following description.			

Settings:

Internal Speed Command 3: The setting of the 3<sup>rd</sup> internal speed command

Internal Speed Limit 3: The setting of the 3<sup>rd</sup> internal speed limit

Example of inputting internal speed limit:

Speed Limit Setting Value of P1-11	Allowable Speed Range	Forward Speed Limit	Reverse Speed Limit
1000	100 ~ 100 r/min	100 r/min	-100 r/min
-1000			

P1-12	TQ1	Internal Torque Command 1 / Internal Torque Limit 1		Address: 0118H 0119H
Operational Interface:	Panel / Software	Communication	Related Section:	6.4.1
Default:	100		Control Mode:	Tz (Internal Torque Command) / DMCNET, Sz (Internal Torque Limit)
Unit:	%		Range:	-300 ~ +300
Format:	DEC		Data Size:	16-bit
Example:	Internal Torque Command: 30 = 30 % Internal Torque Limit: Positive value and negative value are the same. Please refer to the following description.			

Settings:

Internal Torque Command 1: The setting of the 1<sup>st</sup> internal torque command

Internal Torque Limit 1: The setting of the 1<sup>st</sup> internal torque limit

Example of inputting internal torque limit:

Torque Limit Setting Value of P1-12	Allowable Torque Range	Forward Torque Limit	Reverse Torque Limit
30	-30 ~ 30 %	30 %	-30 %
-30			

P1-13	TQ2	Internal Torque Command 2 / Internal Torque Limit 2		Address: 011AH 011BH
Operational Interface:	Panel / Software	Communication	Related Section:	6.4.1
Default:	100		Control Mode:	Tz (Internal Torque Command) / Sz (Internal Torque Limit)
Unit:	%		Range:	-300 ~ +300
Format:	DEC		Data Size:	16-bit
Example:	Internal Torque Command: 30 = 30 % Internal Torque Limit: Positive value and negative value are the same. Please refer to the following description.			

Settings:

Internal Torque Command 2: The setting of the 2<sup>nd</sup> internal torque command

Internal Torque Limit 2: The setting of the 2<sup>nd</sup> internal torque limit

7

Example of inputting internal torque limit:

Torque Limit Setting Value of P1-13	Allowable Torque Range	Forward Torque Limit	Reverse Torque Limit
30	-30 ~ 30 %	30 %	-30 %
-30			

P1-14	TQ3	Internal Torque Command 3 / Internal Torque Limit 3		Address: 011CH 011DH
Operational Interface:	Panel / Software	Communication	Related Section:	6.4.1
Default:	100		Control Mode:	Tz (Internal Torque Command) / Sz (Internal Torque Limit)
Unit:	%		Range:	-300 ~ +300
Format:	DEC		Data Size:	16-bit
Example:	Internal Torque Command: 30 = 30 % Internal Torque Limit: Positive value and negative value are the same. Please refer to the following description.			

Settings:

Internal Torque Command 3: The setting of the 3<sup>rd</sup> internal torque command

Internal Torque Limit 3: The setting of the 3<sup>rd</sup> internal torque limit

Example of inputting internal torque limit:

Torque Limit Setting Value of P1-14	Allowable Torque Range	Forward Torque Limit	Reverse Torque Limit
30	-30 ~ 30 %	30 %	-30 %
-30			

P1-15~P1-24	Reserved

P1-25	VSF1	Low-frequency Vibration Suppression (1)		Address: 0132H 0133H
Operational Interface:	Panel / Software	Communication	Related Section:	6.2.6
Default:	1000		Control Mode:	DMCNET
Unit:	0.1 Hz		Range:	10 ~ 1000
Format:	DEC		Data Size:	16-bit
Example:	150 = 15 Hz			

Settings:

The setting value of the first low-frequency vibration suppression. If P1-26 is set to 0, then it will disable the first low-frequency filter.

P1-26	VSG1	Low-frequency Vibration Suppression Gain (1)		Address: 0134H 0135H
Operational Interface:	Panel / Software	Communication	Related Section:	6.2.6
Default:	0		Control Mode:	DMCNET
Unit:	-		Range:	0 ~ 9 (0: Disable the first low-frequency filter)
Format:	DEC		Data Size:	16-bit

Settings:

The first low-frequency vibration suppression gain. If the value is set to be too big, the motor will not be able to smoothly operate. It is suggested to set the value to 1.

P1-27	VSF2	Low-frequency Vibration Suppression (2)		Address: 0136H 0137H
Operational Interface:	Panel / Software	Communication	Related Section:	6.2.6
Default:	1000		Control Mode:	DMCNET
Unit:	0.1 Hz		Range:	10 ~ 1000
Format:	DEC		Data Size:	16-bit
Example:	150 = 15 Hz			
Settings:	The setting value of the second low-frequency vibration suppression. If P1-28 is set to 0, then it will disable the second low-frequency filter.			

P1-28	VSG2	Low-frequency Vibration Suppression Gain (2)		Address: 0138H 0139H
Operational Interface:	Panel / Software	Communication	Related Section:	6.2.6
Default:	0		Control Mode:	DMCNET
Unit:	-		Range:	0 ~ 9 (0: Disable the second low-frequency filter)
Format:	DEC		Data Size:	16-bit
Settings:	The second low-frequency vibration suppression gain. Higher setting value means better position response. If the value is set to be too big, the motor will not be able to smoothly operate. It is suggested to set the value to 1.			

P1-29	AVSM	Auto Low-frequency Vibration Suppression Setting		Address: 013AH 013BH
Operational Interface:	Panel / Software	Communication	Related Section:	6.2.6
Default:	0		Control Mode:	DMCNET
Unit:	-		Range:	0 ~ 1
Format:	DEC		Data Size:	16-bit
Settings:	0: The auto-detection function is disabled. 1: Set back to 0 after vibration suppression. Description of auto modes setting: When the parameter is set to 1, it is in auto suppression. When the vibration frequency is not being detected or the value of searched frequency is stable, the parameter will be set to 0 and the frequency of low-frequency vibration suppression is saved to P1-25 automatically.			

P1-30	VCL	Low-frequency Vibration Detection		Address: 013CH 013DH
Operational Interface:	Panel / Software	Communication	Related Section:	6.2.6
Default:	500		Control Mode:	DMCNET
Unit:	Pulse		Range:	1 ~ 8000
Format:	DEC		Data Size:	16-bit
Settings:	When auto suppression is enabled (P1-29 = 1), this parameter is used as the detection level. The lower the value is, the more sensitive the detection will be. However, it is easier to misjudge noise or regard other low-frequency vibration as the suppression frequency. If the value is bigger, it will make more precise judgment. However, if the vibration of the mechanism is smaller, it might not detect the frequency of low-frequency vibration.			

P1-31	Reserved			

7

P1-32	LSTP	Motor Stop Mode		Address: 0140H 0141H
Operational Interface:	Panel / Software	Communication	Related Section:	-
Default:	0		Control Mode:	ALL
Unit:	-		Range:	0 ~ 20
Format:	HEX		Data Size:	16-bit

Settings:

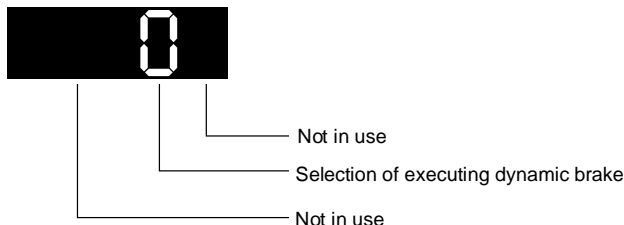

- Selection of executing dynamic brake: stop mode when servo off or alarm (including EMGS) occurs.
- 0: Use dynamic brake  
 1: Motor free run  
 2: Use dynamic brake first, then execute free run until it stops (The motor speed is slower than P1-38).  
 When PL(CCWL) or NL(CWL) occurs, please refer to the event time setting value of P5-03 for determining the deceleration time. If the setting is 1 ms, the motor stops instantaneously.

P1-33	Reserved
-------	----------

P1-34	TACC	Acceleration Constant of S-Curve		Address: 0144H 0145H
Operational Interface:	Panel / Software	Communication	Related Section:	6.3.3
Default:	200		Control Mode:	Sz
Unit:	ms		Range:	1 ~ 65500
Format:	DEC		Data Size:	16-bit

Settings:

Acceleration constant:  
 P1-34, P1-35 and P1-36, the acceleration time of speed command from zero to the rated speed, all can be set individually. Even when P1-36 is set to 0, the curve is still planned by P1-34 and P1-35.

P1-35	TDEC	Deceleration Constant of S-Curve		Address: 0146H 0147H
Operational Interface:	Panel / Software	Communication	Related Section:	6.3.3
Default:	200		Control Mode:	Sz
Unit:	ms		Range:	1 ~ 65500
Format:	DEC		Data Size:	16-bit

Settings:

Deceleration constant:  
 P1-34, P1-35 and P1-36, the deceleration time of speed command from the rated speed to zero, all can be set individually. Even when P1-36 is set to 0, the curve is still planned by P1-34 and P1-35.

P1-36	TSL	Acceleration / Deceleration Constant of S-Curve		Address: 0148H 0149H
Operational Interface:	Panel / Software	Communication	Related Section:	6.3.3
Default:	0		Control Mode:	Sz, DMCNET
Unit:	ms		Range:	0 ~ 65500 (0: Disable this function)
Format:	DEC		Data Size:	16-bit

Settings:

Acceleration / Deceleration Constant of S-Curve:

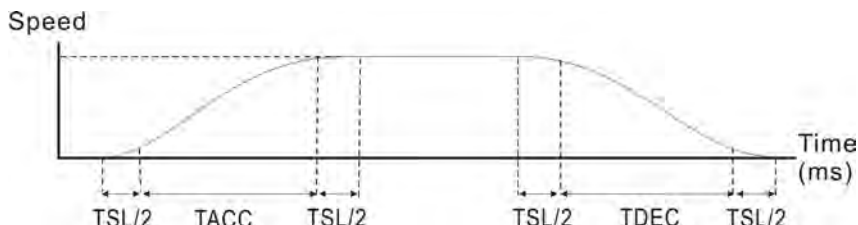

P1-34: Set the acceleration time of acceleration / deceleration of trapezoid curve.  
 P1-35: Set the deceleration time of acceleration / deceleration of trapezoid curve.  
 P1-36: Set the smoothing time of S-curve acceleration / deceleration.  
 P1-34, P1-35 and P1-36 can be set individually. Even when P1-36 is set to 0, the curve is still planned by P1-34 and P1-35.

Compensation function of following error is provided.

	P1-36 = 0	P1-36 = 1	P-36 > 1
Smoothing function of S-curve	Disable	Disable	Enable
Compensation function of following error	Disable	Enable	Determined by P2-68.X

P1-37	GDR	Inertia Ratio and Load Weight Ratio to Servo Motor		Address: 014AH 014BH
Operational Interface:	Panel / Software	Communication	Related Section:	-
Default:	1.0	10	Control Mode:	ALL
Unit:	1 times	0.1 times	Data Size:	16-bit
Range:	0.0 ~ 200.0	0 ~ 2000	-	-
Format:	One decimal	DEC	-	-
Example:	1.5 = 1.5 times	15 = 1.5 times	-	-

Settings:

Inertia ratio to servo motor (rotary motor):

(J\_load / J\_motor)

Among them:

J\_motor: Rotor inertia of the servo motor

J\_load: Total equivalent inertia of external mechanical load

Load weight inertia to servo motor (linear motor) (will be available soon):

(M\_load / M\_motor)

Among them:

M\_motor: The weight of servo motor

M\_load: Total equivalent weight of external mechanical load

7

P1-38	ZSPD	Zero Speed Range Setting			Address: 014CH 014DH
Operational Interface:	Panel / Software	Communication	Related Section:	Table 7.2	
Default:	10.0	100	Control Mode:	ALL	
Unit:	1 r/min	0.1 r/min	Data Size:	16-bit	
Range:	0.0 ~ 200.0	0 ~ 2000	-	-	
Format:	One decimal	DEC	-	-	
Example:	1.5 = 1.5 r/min	15 = 1.5 r/min	-	-	

Settings:

Setting the output range of zero-speed signal (ZSPD). When the forward / reverse speed of the motor is slower than the setting value, the digital output will be enabled.

P1-39	SSPD	Target Speed Detection Level			Address: 014EH 014FH
Operational Interface:	Panel / Software	Communication	Related Section:	Table 7.2	
Default:	3000		Control Mode:	ALL	
Unit:	r/min		Range:	0 ~ 5000	
Format:	DEC		Data Size:	16-bit	

Settings:

When the target speed is reached, DO.TSPD is enabled. When the forward / reverse speed of the motor is higher than the setting value, the digital output will be enabled.

<b>P1-40 ~ P1-41</b>	<b>Reserved</b>				
----------------------	-----------------	--	--	--	--

P1-42	MBT1	Enable Delay Time of Brake			Address: 0154H 0155H
Operational Interface:	Panel / Software	Communication	Related Section:	6.5	
Default:	0		Control Mode:	ALL	
Unit:	ms		Range:	0 ~ 1000	
Format:	DEC		Data Size:	16-bit	

Settings:

Set the delay time between servo on and DO.BRKR (signal of brake) on.

P1-43	MBT2	Disable Delay Time of Brake			Address: 0156H 0157H
Operational Interface:	Panel / Software	Communication	Related Section:	6.5	
Default:	0		Control Mode:	ALL	
Unit:	ms		Range:	-1000 ~ 1000	
Format:	DEC		Data Size:	16-bit	

Settings:

Set the delay time between servo off and DO.BRKR (signal of brake) off.

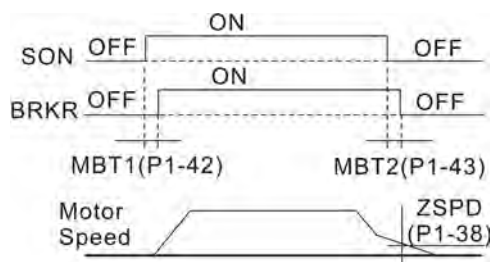

Note:

1. If the delay time specified by P1-43 is not over yet and the motor speed is slower than the value of P1-38, the signal of brake (BRKR) is off.
2. If the delay time of P1-43 is up and the motor speed is higher than the value of P1-38, the signal of brake (BRKR) is off.
3. If P1-43 is set to a negative value and the servo is off due to alarm (except AL022) or emergency stop, its setting will be equivalent to 0.

P1-44▲	GR1	Gear Ratio (Numerator) (N1)		Address: 0158H 0159H
Operational Interface:	Panel / Software	Communication	Related Section:	6.2.3
Default:	128		Control Mode:	DMCNET
Unit:	Pulse		Range:	1 ~ (2 <sup>29</sup> -1)
Format:	DEC		Data Size:	32-bit

Settings:

Please refer to P2-60 ~ P2-62 for the setting of multiple gear ratio (numerator).

Note:

In DMCNET mode, the setting value can only be modified when Servo Off.

P1-45	GR2	Gear Ratio (Denominator) (M)		Address: 015AH 015BH
Operational Interface:	Panel / Software	Communication	Related Section:	6.2.3
Default:	10		Control Mode:	DMCNET
Unit:	Pulse		Range:	1 ~ (2 <sup>31</sup> -1)
Format:	DEC		Data Size:	32-bit

Settings:

If the setting is wrong, the servo motor will easily have sudden unintended acceleration. Please follow the rules for setting:

The setting of pulse input:

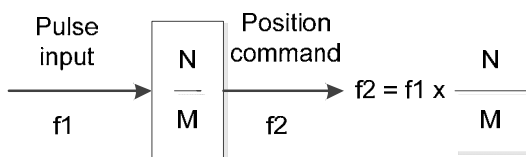

Range of command pulse input: 1/50 < Nx / M < 25600

Note:

The setting value cannot be changed when Servo On.

P1-46▲	GR3	Pulse Number of Encoder Output		Address: 015CH 015DH
Operational Interface:	Panel / Software	Communication	Related Section:	-
Default:	2500		Control Mode:	ALL
Unit:	Pulse		Range:	20 ~ 320000
Format:	DEC		Data Size:	32-bit

Settings:

The number of single-phase pulse output per revolution. The max. output pulse frequency of the hardware is 19.8 MHz.

Note:

The following circumstances might exceed the max. allowable output pulse frequency and AL018 may occur.

1. Abnormal encoder
2. The motor speed is faster than the setting speed of P1-76

$$3. \frac{\text{Motor Speed}}{60} \times P1 - 46 \times 4 > 19.8 \times 10^6$$

P1-47	SPOK	Speed Reached (DO.SP_OK) Range		Address: 015EH 015FH
Operational Interface:	Panel / Software	Communication	Related Section:	-
Default:	10		Control Mode:	Sz
Unit:	r/min		Range:	0 ~ 300
Format:	DEC		Data Size:	16-bit

Settings:

When the deviation between speed command and motor feedback speed is smaller than the value of this parameter, then the digital output DO.SP\_OK (DO code is 0x19) is ON.

Block diagram:

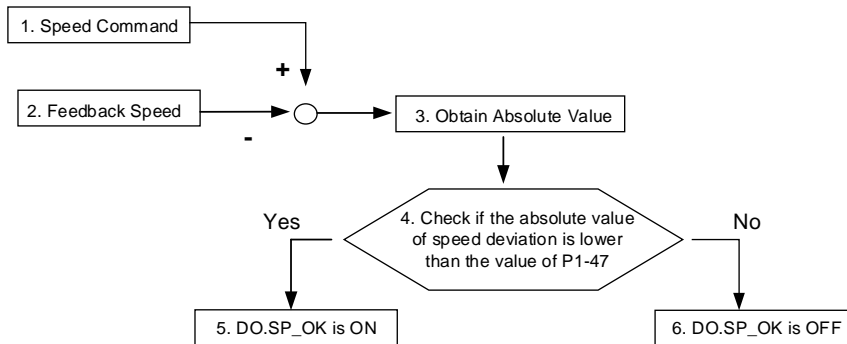

1. Speed command: It is the command issued by the user (without acceleration / deceleration), not the one of front end speed loop. Source: register
2. Feedback speed: The actual speed of the motor which has been processed by the filter.
3. Obtain the absolute value.
4. Check if the value is smaller than the value of P1-47. DO.SP\_OK will be ON when the absolute value of speed error is smaller than P1-47, or it will be OFF. If P1-47 is 0, DO.SP\_OK is always OFF.

P1-48	MCOK	Operation Selection of Motion Reached (DO.MC_OK)		Address: 0160H 0161H
Operational Interface:	Panel / Software	Communication	Related Section:	-
Default:	0		Control Mode:	DMCNET
Unit:	-		Range:	0x0000 ~ 0x0011
Format:	HEX		Data Size:	16-bit

Settings:

Control selection of digital output DO.MC\_OK (DO code is 0x17).

The format of this parameter: 00YX

X= 0: It will not remain the digital output status

1: It will remain the digital output status

Y= 0: AL380 (position deviation) is not working

1: AL380 (position deviation) is working

Block diagram:

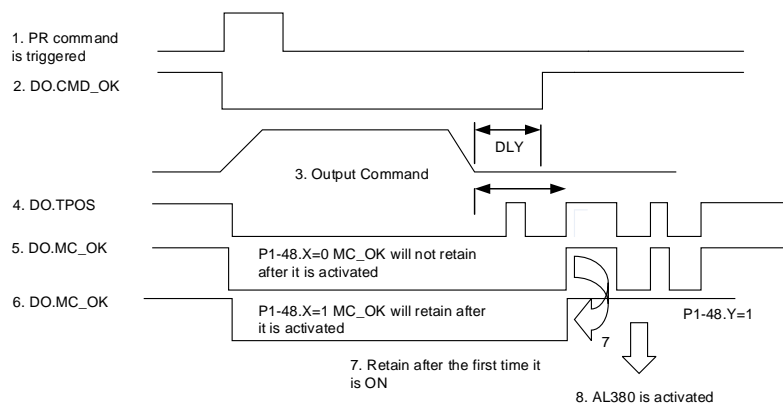

Description:

1. Command triggered: It means the new PR command is effective. Position command 3 starts to output and clear signal 2, 4, 5 and 6 at the same time. Source of command triggered: DI.CTRG, DI.EV1 / EV2 and software trigger P5-07, etc.
2. DO.CMD\_OK: It means the position command 3 is completely outputted and can set the delay time (DLY).
3. Command output: Output the profile of position command according to the setting acceleration / deceleration.

4. DO.TPOS: It means the position error of the servo drive is within the value of P1-54.
5. DO.MC\_OK: It means the position command is completely outputted and the servo finishes positioning. MC\_OK is ON if CMD\_OK and TPOS are both ON.
6. DO.MC\_OK (remains the digital output status): It is the same as 5. However, once this DO is ON (7), its status will remain regardless signal 4 is OFF or not.
7. Outputting signal 5 or 6 (Only one can be selected) is determined by parameter P1-48.X.
8. Position deviation: When 7 happens, if 4 (or 5) is OFF, it means the position is deviated and AL380 can be triggered. Set this alarm via parameter P1-48.Y.

P1-49	SPOKWT	Accumulative Time of Speed Reached			Address: 0162H 0163H
Operational Interface:	Panel / Software	Communication	Related Section:	Table 7.2	
Default:	0		Control Mode:	Sz	
Unit:	ms		Range:	0 ~ 65535	
Format:	DEC		Data Size:	16-bit	

Settings:

In speed mode, when the deviation value between speed command and motor feedback speed is smaller than the range set by P1-47 and reaches the time set by P1-49, DO.SP\_OK (DO code is 0x19) will be ON. If the deviation value exceeds the range set by P1-47, it has to recount the time.

P1-50 ~ P1-51	Reserved				
---------------	----------	--	--	--	--

P1-52	RES1	Regenerative Resistor Value			Address: 0168H 0169H
Operational Interface:	Panel / Software	Communication	Related Section:	2.7	
Default:	Determined by the model. Please refer to the following table.		Control Mode:	ALL	
Unit:	Ohm		Range:	5 ~ 750	
Format:	DEC		Data Size:	16-bit	

Settings:

Model	Default (Ω)
100 ~ 200 W	100
400 W	100
750 kW	100
1 kW	40
1.5 kW	40
2 kW	20
3 kW	20

Please refer to the description of P1-53 for the setting value when connecting regenerative resistor with different method.

P1-53	RES2	Regenerative Resistor Capacity			Address: 016AH 016BH
Operational Interface:	Panel / Software	Communication	Related Section:	2.7	
Default:	Determined by the model. Please refer to the following table.		Control Mode:	ALL	
Unit:	Watt		Range:	0 ~ 6000	
Format:	DEC		Data Size:	16-bit	

Settings:

Model	Default (Ω)
100 ~ 200 W	0
400 W	60
750 kW	60
1 kW	60

# 7

1.5 kW	60
2 kW	100
3 kW	100

Following describes the setting value of P1-52 and P1-53 when connecting regenerative resistor with different method:

External regenerative resistor

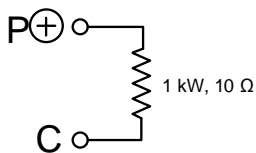

Setting:  
P1-52 = 10 (Ω)  
P1-53 = 1000 (W)

External regenerative resistor (serial connection)

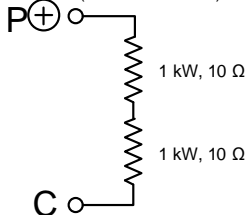

Setting:  
P1-52 = 20 (Ω)  
P1-53 = 2000 (W)

External regenerative resistor (parallel connection)

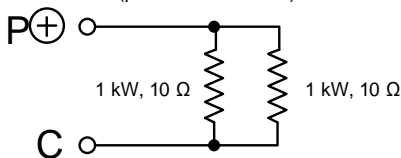

Setting:  
P1-52 = 5 (Ω)  
P1-53 = 2000 (W)

P1-54	PER	Position Completed Range		Address: 016CH 016DH
Operational Interface:	Panel / Software	Communication	Related Section:	Table 7.2
Default:	12800		Control Mode:	DMCNET
Unit:	Pulse		Range:	0 ~ 1280000
Format:	DEC		Data Size:	32-bit

Settings:

In DMCNET mode, if the deviation pulse number is smaller than the setting range (the setting value of parameter P1-54), DO.TPOS is ON.

P1-55	MSPD	Maximum Speed Limit		Address: 016EH 016FH
Operational Interface:	Panel / Software	Communication	Related Section:	-
Default:	Same as the rated speed of each model.		Control Mode:	ALL
Unit:	r/min		Range:	10 ~ max.speed
Format:	DEC		Data Size:	16-bit

Settings:

The default of the max. speed of servo motor is set to the rated speed.

P1-56	OVW	Output Overload Warning Level		Address: 0170H 0171H
Operational Interface:	Panel / Software	Communication	Related Section:	-
Default:	120		Control Mode:	ALL
Unit:	%		Range:	0 ~ 120
Format:	DEC		Data Size:	16-bit

Settings:

The range of the setting value is 0 ~ 100. If the torque outputted by the servo motor is continuously higher than the setting proportion (P1-56), the early warning for overload (DO is set to 10, OLW) will occur. If the setting value is over 100, it will disable this function.

P1-57	CRSHA	Motor Crash Protection (torque percentage)		Address: 0172H 0173H
Operational Interface:	Panel / Software	Communication	Related Section:	-
Default:	0		Control Mode:	ALL
Unit:	%		Range:	0 ~ 300
Format:	DEC		Data Size:	16-bit

Settings:

Set up protection level. (For the percentage of rated torque, setting the value to 0 means to disable the function; setting the value to 1 or above means to enable the function)

P1-58	CRSHT	Motor Crash Protection (protection time)		Address: 0174H 0175H
Operational Interface:	Panel / Software	Communication	Related Section:	-
Default:	1		Control Mode:	ALL
Unit:	ms		Range:	1 ~ 1000
Format:	DEC		Data Size:	16-bit

Settings:

Set up the protection time: When the protection level is reached, AL030 occurs after exceeding the protection time.

Note:

This function is only suitable for non-contactable application, such as electric discharge machines. (Please set up P1-37 correctly).

<b>P1-59 ~ P1-61</b>	<b>Reserved</b>			
----------------------	-----------------	--	--	--

P1-62	FRCL	Friction Compensation		Address: 017CH 017DH
Operational Interface:	Panel / Software	Communication	Related Section:	-
Default:	0		Control Mode:	DMCNET, Sz
Unit:	%		Range:	0 ~ 100
Format:	DEC		Data Size:	16-bit

Settings:

The level of friction compensation. (For the percentage of rated torque, setting the value to 0 means to disable the function; setting the value to 1 or above means to enable the function)

P1-63	FRCT	Friction Compensation		Address: 017EH 017FH
Operational Interface:	Panel / Software	Communication	Related Section:	-
Default:	1		Control Mode:	DMCNET, Sz
Unit:	ms		Range:	1 ~ 1000
Format:	DEC		Data Size:	16-bit

7

Settings:  
Set up the smooth constant of friction compensation.

<b>P1-64 ~ P1-67</b>	<b>Reserved</b>		
----------------------	-----------------	--	--

<b>P1-68</b>	<b>PFLT2</b>	<b>Position Command Moving Filter</b>		<b>Address: 0188H 0189H</b>
Operational Interface:	Panel / Software	Communication	Related Section:	-
Default:	4		Control Mode:	DMCNET
Unit:	ms		Range:	0 ~ 100
Format:	DEC		Data Size:	16bit

Settings:  
0: Disabled  
Moving filter can activate smooth function in the beginning and the end of step command, but it will delay the command.

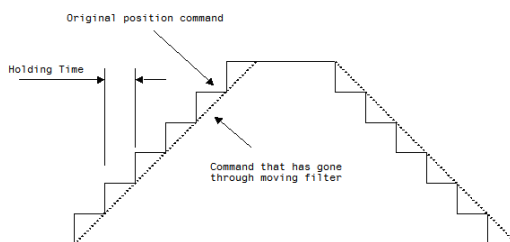

<b>P1-69 ~ P1-75</b>	<b>Reserved</b>		
----------------------	-----------------	--	--

<b>P1-76</b>	<b>AMSPD</b>	<b>Maximum Rotation Setting of Encoder Output (OA, OB)</b>		<b>Address: 0198H 0199H</b>
Operational Interface:	Panel / Software	Communication	Related Section:	P1-46
Default:	5500		Control Mode:	ALL
Unit:	r/min		Range:	0 ~ 6000
Format:	DEC		Data Size:	16-bit

Settings:  
According to the real application, this parameter is set for the maximum speed and the servo drive will generate smooth function automatically for encoder output signals. When the value is set to 0, the function is disabled.

<b>P1-77~P1-83</b>	<b>Reserved</b>		
--------------------	-----------------	--	--

## P2-xx Extension Parameters

P2-00	KPP	Position Loop Gain			Address: 0200H 0201H
Operational Interface:	Panel / Software	Communication	Related Section:	6.2.5	
Default:	35		Control Mode:	DMCNET	
Unit:	rad/s		Range:	0 ~ 2047	
Format:	DEC		Data Size:	16-bit	

**Settings:**

Increasing the value of position loop gain can enhance the position response and diminish the deviation of position control. However, if the value is set to be too big, it may easily cause vibration and noise.

P2-01	PPR	Switching Rate of Position Loop Gain			Address: 0202H 0203H
Operational Interface:	Panel / Software	Communication	Related Section:	6.2.5	
Default:	100		Control Mode:	DMCNET	
Unit:	%		Range:	10 ~ 500	
Format:	DEC		Data Size:	16-bit	

**Settings:**

Switch the changing rate of position loop gain according to the gain-switching condition.

P2-02	PFG	Position Feed Forward Gain			Address: 0204H 0205H
Operational Interface:	Panel / Software	Communication	Related Section:	6.2.5	
Default:	50		Control Mode:	DMCNET	
Unit:	%		Range:	0 ~ 100	
Format:	DEC		Data Size:	16-bit	

**Settings:**

If the position command is changed smoothly, increasing the gain value can reduce the position error. If the position command is not changed smoothly, decreasing the gain value can tackle the problem of mechanical vibration.

P2-03	PFF	Smooth Constant of Position Feed Forward Gain			Address: 0206H 0207H
Operational Interface:	Panel / Software	Communication	Related Section:	-	
Default:	5		Control Mode:	DMCNET	
Unit:	ms		Range:	2 ~ 100	
Format:	DEC		Data Size:	16-bit	

**Settings:**

If the position command is changed smoothly, decreasing the value can reduce the position following error. If the position command is not changed smoothly, increasing the value can tackle the problem of mechanical vibration.

P2-04	KVP	Speed Loop Gain			Address: 0208H 0209H
Operational Interface:	Panel / Software	Communication	Related Section:	6.3.5	
Default:	500		Control Mode:	ALL	
Unit:	rad/s		Range:	0 ~ 8191	
Format:	DEC		Data Size:	16-bit	

**Settings:**

Increasing the value of speed loop gain can enhance the speed response. However, if the value is set to be too big, it would easily cause vibration and noise.

7

P2-05	SPR	Switching Rate of Speed Loop Gain		Address: 020AH 020BH
Operational Interface:	Panel / Software	Communication	Related Section:	-
Default:	100		Control Mode:	ALL
Unit:	%		Range:	10 ~ 500
Format:	DEC		Data Size:	16-bit

Settings:

Switch the changing rate of speed loop gain according to the gain switching condition.

P2-06	KVI	Speed Integral Compensation		Address: 020CH 020DH
Operational Interface:	Panel / Software	Communication	Related Section:	6.3.5
Default:	100		Control Mode:	ALL
Unit:	rad/s		Range:	0 ~ 1023
Format:	DEC		Data Size:	16-bit

Settings:

Increasing the value of speed integral compensation can enhance speed response and diminish the deviation of speed control. However, if the value is set to be too big, it would easily cause vibration and noise.

P2-07	KVF	Speed Feed Forward Gain		Address: 020EH 020FH
Operational Interface:	Panel / Software	Communication	Related Section:	6.3.5
Default:	0		Control Mode:	ALL
Unit:	%		Range:	0 ~ 100
Format:	DEC		Data Size:	16-bit

Settings:

If the speed command is changed smoothly, increasing the gain value can reduce the speed following error. If the speed command is not changed smoothly, decreasing the gain value can tackle the problem of mechanical vibration.

P2-08■	PCTL	Special Parameter Write-in		Address: 0210H 0211H
Operational Interface:	Panel / Software	Communication	Related Section:	-
Default:	0		Control Mode:	ALL
Unit:	-		Range:	0 ~ 65535
Format:	DEC		Data Size:	16-bit

Settings:

Special parameter write-in:

Parameter Code	Function
10	Reset the parameter (Conenct to the power again after reset)
20	P4-10 is writable
22	P4-11 ~ P4-21 are writable
406	Enable forced DO mode
400	When forced DO mode is enabled, it can switch back to the normal DO mode immediately

P2-09	DRT	DI Debouncing Time		Address: 0212H 0213H
Operational Interface:	Panel / Software	Communication	Related Section:	-
Default:	2		Control Mode:	ALL
Unit:	1 ms		Range:	0 ~ 20
Format:	DEC		Data Size:	16-bit

Settings:  
 When the environmental noise is big, increasing the setting value can enhance the control stability.  
 However, if the value is set to be too big, the response time will be influenced.

P2-10	DI1	DI1 Functional Planning		Address: 0214H 0215H
Operational Interface:	Panel / Software	Communication	Related Section:	Table 7.1
Default:	101		Control Mode:	ALL
Unit:	-		Range:	0 ~ 0x015F (The last two codes are DI code)
Format:	HEX		Data Size:	16-bit

Settings:

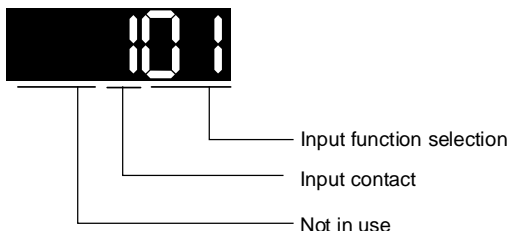

- Input function selection: Please refer to Table 7.1
  - Input contact: a or b contact
    - 0: Set the input contact as normally closed (b contact)
    - 1: Set the input contact as normally opened (a contact)
- (P2-10 ~ P2-17) The setting value of function programmed

When parameters are modified, please re-start the servo drive to ensure it can work normally.

Note: Parameter P3-06 is used to set how digital inputs (DI) accept commands, through external terminal or communication determined by P4-07.

P2-11	DI2	DI2 Functional Planning		Address: 0216H 0217H
Operational Interface:	Panel / Software	Communication	Related Section:	Table 7.1
Default:	104		Control Mode:	ALL
Unit:	-		Range:	0 ~ 0x015F (The last two codes are DI code)
Format:	HEX		Data Size:	16-bit

Settings:

Please refer to the description of P2-10.

P2-12	DI3	DI3 Functional Planning		Address: 0218H 0219H
Operational Interface:	Panel / Software	Communication	Related Section:	Table 7.1
Default:	022		Control Mode:	ALL
Unit:	-		Range:	0 ~ 0x015F (The last two codes are DI code)
Format:	HEX		Data Size:	16-bit

Settings:

Please refer to the description of P2-10.

7

P2-13	DI4	DI4 Functional Planning		Address: 021AH 021BH
Operational Interface:	Panel / Software	Communication	Related Section:	Table 7.1
Default:	023		Control Mode:	ALL
Unit:	-		Range:	0~ 0x15F (The last two codes are DI code)
Format:	HEX		Data Size:	16-bit

Settings:  
Please refer to the description of P2-10.

P2-14	DI5	DI5 Functional Planning		Address: 021CH 021DH
Operational Interface:	Panel / Software	Communication	Related Section:	Table 7.1
Default:	021		Control Mode:	ALL
Unit:	-		Range:	0 ~ 0x015F (The last two codes are DI code)
Format:	HEX		Data Size:	16-bit

Settings:  
Please refer to the description of P2-10.

<b>P2-15~P2-17</b>	<b>Reserved</b>			
--------------------	-----------------	--	--	--

P2-18	DO1	DO1 Functional Planning		Address: 0224H 0225H
Operational Interface:	Panel / Software	Communication	Related Section:	Table 7.2
Default:	101		Control Mode:	ALL
Unit:	-		Range:	0 ~ 0x013F (The last two codes are DO code)
Format:	HEX		Data Size:	16-bit

Settings:

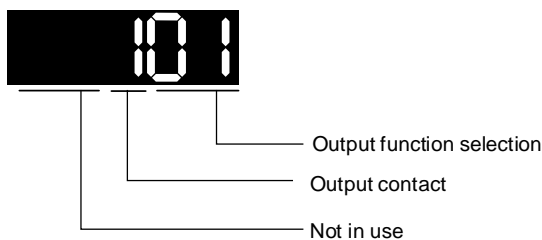

- Output function selection: Please refer to Table 7.2
  - Output contact: a or b contact
    - 0: Set the output contact as normally closed (b contact)
    - 1: Set the output contact as normally opened (a contact)
- (P2-18 ~ P2-22) The setting value of function programmed  
When parameters are modified, please re-start the servo drive to ensure it can work normally.

P2-19	DO2	DO2 Functional Planning		Address: 0226H 0227H
Operational Interface:	Panel / Software	Communication	Related Section:	Table 7.2
Default:	103		Control Mode:	ALL
Unit:	-		Range:	0 ~ 0x013F (The last two codes are DO code)
Format:	HEX		Data Size:	16-bit

Settings:  
Please refer to the description of P2-18

<b>P2-20~P2-22</b>	Reserved		
--------------------	----------	--	--

<b>P2-23</b>	<b>NCF1</b>	<b>Resonance Suppression (Notch Filter) (1)</b>		<b>Address: 022EH 022FH</b>
Operational Interface:	Panel / Software	Communication	Related Section:	6.3.6
Default:	1000		Control Mode:	ALL
Unit:	Hz		Range:	50 ~ 1000
Format:	DEC		Data Size:	16-bit

## Settings:

The first setting value of resonance frequency. If P2-24 is set to 0, this function is disabled. P2-43 and P2-44 are for the second notch filter.

<b>P2-24</b>	<b>DPH1</b>	<b>Resonance Suppression (Notch Filter) Attenuation Rate (1)</b>		<b>Address: 0230H 0231H</b>
Operational Interface:	Panel / Software	Communication	Related Section:	6.3.6
Default:	0		Control Mode:	ALL
Unit:	-dB		Range:	0 ~ 32 (0: Disable the function of notch filter)
Format:	DEC		Data Size:	16-bit

## Settings:

The first resonance suppression (notch filter) attenuation rate. When this parameter is set to 0, the function of notch filter is disabled.

## Note:

If the value of attenuation rate is set to 5, then, it would be -5dB.

<b>P2-25</b>	<b>NLP</b>	<b>Low-pass Filter of Resonance Suppression</b>		<b>Address: 0232H 0233H</b>
Operational Interface:	Panel / Software	Communication	Related Section:	6.3.6
Default:	0.2 (under 1 kW) or 0.5 (other model)	2 (under 1kW) or 5 (othe model)	Control Mode:	ALL
Unit:	1 ms	0.1 ms	Data Size:	16-bit
Range:	0.0 ~ 100.0	0 ~ 1000	-	-
Format:	One decimal	DEC	-	-
Example:	1.5 = 1.5 ms	15 = 1.5 ms	-	-

## Settings:

Set the low-pass filter of resonance suppression. When the value is set to 0, the function of low-pass filter is disabled.

<b>P2-26</b>	<b>DST</b>	<b>Anti-interference Gain</b>		<b>Address: 0234H 0235H</b>
Operational Interface:	Panel / Software	Communication	Related Section:	-
Default:	0		Control Mode:	ALL
Unit:	rad/s		Range:	0 ~ 1023 (0: Disable this function)
Format:	DEC		Data Size:	16-bit

## Settings:

Increasing the value of this parameter can increase the damping of speed loop. It is suggested to set the value of P2-26 equal to the one of P2-06. If users desire to adjust P2-26, please follow the rules below.

1. In speed mode, increasing the value of this parameter can reduce speed overshoot.
2. In position mode, decreasing the value of this parameter can reduce position overshoot.

7

P2-27	GCC		Gain Switching and Switching Selection	Address: 0236H 0237H
Operational Interface:	Panel / Software	Communication	Related Section:	-
Default:	0		Control Mode:	ALL
Unit:	-		Range:	0x0000 ~ 0x0018
Format:	HEX		Data Size:	16-bit

Settings:

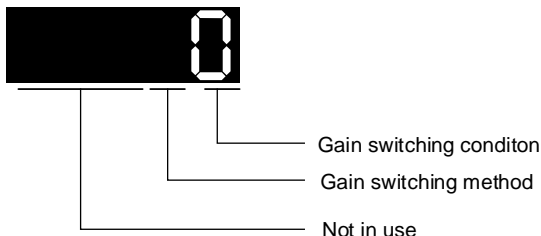

- Gain switching condition:
  - 0: Disable gain switching function.
  - 1: The signal of gain switching (GAINUP) is ON.
  - 2: In position control mode, the position error is bigger than the setting value of P2-29.
  - 3: The frequency of position command is bigger than the setting value of P2-29.
  - 4: The speed of servo motor is faster than the setting value of P2-29.
  - 5: The signal of gain switching (GAINUP) is OFF.
  - 6: In position control mode, the position error is smaller than the setting value of P2-29.
  - 7: The frequency of position command is smaller than the setting value of P2-29.
  - 8: The speed of servo motor is slower than the setting value of P2-29.

- Gain switching method:
  - 0: Gain switching
  - 1: Integrator switching P -> PI

Setting Value	Control Mode DMCNET	Control Mode Sz	-
0	P2-00 x 100% P2-04 x 100%	P2-04 x 100%	Before switching
	P2-00 x P2-01 P2-04 x P2-05	P2-04 x P2-05	After switching
1	P2-06 x 0%; P2-26 x 0%		Before switching
	P2-06 x 100%; P2-26 x 100%		After switching

P2-28	GUT		Gain Switching Time Constant	Address: 0238H 0239H
Operational Interface:	Panel / Software	Communication	Related Section:	-
Default:	10		Control Mode:	ALL
Unit:	10 ms		Range:	0 ~ 1000
Format:	DEC		Data Size:	16-bit
Example:	15 = 150 ms			

Settings:  
It is for switching the smooth gain. (0: Disable this function)

P2-29	GPE		Gain Switching	Address: 023AH 023BH
Operational Interface:	Panel / Software	Communication	Related Section:	-
Default:	1280000		Control Mode:	ALL
Unit:	Pulse, Kpps, r/min		Range:	0 ~ 3840000
Format:	DEC		Data Size:	32-bit

Settings:  
The setting of gain switching (pulse, Kpps, r/min) is determined by the selection of gain switching (P2-27).

P2-30■	INH		Auxiliary Function		Address: 023CH 023DH
Operational Interface:	Panel / Software	Communication	Related Section:	-	
Default:	0		Control Mode:	ALL	
Unit:	-		Range:	-8 ~ +8	
Format:	DEC		Data Size:	16-bit	

Settings:

0	Disable all the functions described below.
1	Use the software to force servo on.
2 ~ 4	(Reserved)
5	This setting allows the written parameters not to retain after power-off. If there is no need to save the data continuously written via panel or communication, this function can avoid the parameters from continuously writing into EEPROM and shorten the lifetime of EEPROM. Setting this parameter is a must when communication control is used.
6	In simulation mode (command simulation), the external servo on signal cannot work and DSP error (variable 0x6F) is regarded as 0. P0-01 only shows the external error (positive / negative limit, emergency stop, etc.) In this status, DO.SRDY is ON. Command is accepted in each mode and can be observed via scope software. However, the motor will not operate. The aim is to examine the command accuracy.
7	High-speed oscilloscope. Time-Out function is disabled. (It is for PC software)
8	Back up all the parameters (current value) and save it to EEPROM. The value still exists when re-power on. The panel displays "to.rom" during execution.(It can be executed when Servo On)
-1,-5,-6,-7	Individually disable the function of 1, 5, 6 and 7.
-2 ~ -4, -8	(Reserved)

Note:

Please set the value to 0 in normal operation. The value returns to 0 automatically after re-power on.

P2-31	AUT1	Speed Loop Frequency Response Setting in Auto and Semi-auto Mode		Address: 023EH 023FH
Operational Interface:	Panel / Software	Communication	Related Section:	5.6, 6.3.5
Default:	40		Control Mode:	ALL
Unit:	Hz		Range:	1 ~ 1000
Format:	HEX		Data Size:	16-bit

Settings:

1 ~ 50 Hz:	Low stiffness, low response
51 ~ 250 Hz:	Medium stiffness, medium response
251 ~ 850 Hz:	High stiffness, high response
851 ~ 1000 Hz:	Extremely high stiffness, extremely high response

Note:

1. According to the speed loop setting of P2-31, the servo drive sets the position loop response automatically.
2. The function is enabled via parameter P2-32. Please refer to Chapter 5.6 for corresponding bandwidth size of the setting value.

P2-32▲	AUT2	Tuning Mode Selection		Address: 0240H 0241H
Operational Interface:	Panel / Software	Communication	Related Section:	5.6, 6.3.5
Default:	0		Control Mode:	ALL
Unit:	-		Range:	0 ~ 2
Format:	HEX		Data Size:	16-bit

# 7

Settings:

- 0: Manual Mode
- 1: Auto Mode (continuous adjustment)
- 2: Semi-auto Mode (non-continuous adjustment)

Description of manual mode setting:

When P2-32 is set to 0, parameters related to gain control, such as P2-00, P2-02, P2-04, P2-06, P2-07, P2-25 and P2-26, all can be set by the user. When switching mode from auto or semi-auto mode to manual mode, gain-related parameters will be updated automatically.

Description of auto mode setting:

Continue to estimate the system inertia. Automatically save the load inertia ratio to P1-37 every 30 minutes and refer to the stiffness and bandwidth setting of P2-31.

1. Set the system to manual mode 0 from auto mode 1 or semi-auto mode 2. The system will save the estimated load inertia value to P1-37 automatically and set the corresponding parameters.
2. Set the system to auto mode 1 or semi-auto mode 2 from manual mode 0. Please set appropriate load inertia value in P1-37.
3. Set the system to manual mode 0 from auto mode 1. P2-00, P2-04 and P2-06 will be modified to the corresponding parameters in auto mode.
4. Set the system to manual mode 0 from semi-auto mode 2. P2-00, P2-04, P2-06, P2-25 and P2-26 will be modified to the corresponding parameters in auto mode.

Description of semi-auto mode setting:

1. When the system inertia is stable, the value of P2-33 will be 1 and the system stops estimating. The load inertia ratio will be saved to P1-37 automatically. When switching from other modes to semi-auto mode (from manual mode or auto mode), the system starts to estimate again.
2. When the system inertia is over the range, the value of P2-33 will be 0 and the system starts to estimate and adjust again.

P2-33▲	AUT3	Semi-auto Inertia Adjustment			Address: 0242H 0243H
Operational Interface:	Panel / Software	Communication	Related Section:	-	
Default:	0		Control Mode:	ALL	
Unit:	-		Range:	0 ~ 1	
Format:	DEC		Data Size:	16-bit	

Settings:

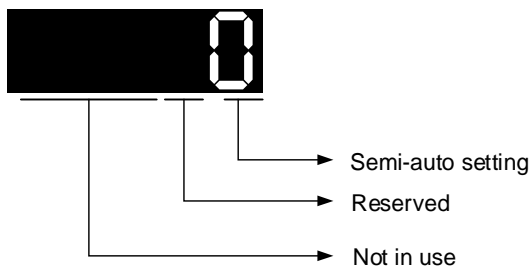

Semi-auto Setting:

- 1: It means the inertia estimation in semi-auto mode is completed. The inertia value can be accessed via P1-37.
- 0: When the display is 0, it means the inertia adjustment is not completed yet and is still adjusting. When the setting is 0, it means the inertia adjustment is not completed yet and is still adjusting.

P2-34	SDEV	Condition of Over Speed Warning			Address: 0244H 0245H
Operational Interface:	Panel / Software	Communication	Related Section:	-	
Default:	5000		Control Mode:	Sz	
Unit:	r/min		Range:	1 ~ 5000	
Format:	DEC		Data Size:	16-bit	

Settings:

It is the setting for over speed warning in servo drive error display (P0-01).

P2-35	PDEV	Condition of Excessive Position Control Deviation Warning		Address: 0246H 0247H
Operational Interface:	Panel / Software	Communication	Related Section:	-
Default:	3840000		Control Mode:	DMCNET
Unit:	Pulse		Range:	1 ~ 128000000
Format:	DEC		Data Size:	32-bit

Settings:  
It is the setting of excessive position control deviation warning in servo drive error display (P0-01).

P2-36~P2-42	Reserved			
-------------	----------	--	--	--

P2-43	NCF2	Resonance Suppression (Notch Filter) (2)		Address: 0256H 0257H
Operational Interface:	Panel / Software	Communication	Related Section:	6.3.6
Default:	1000		Control Mode:	ALL
Unit:	Hz		Range:	50 ~ 2000
Format:	DEC		Data Size:	16-bit

Settings:  
The second setting value of resonance frequency. If P2-44 is set to 0, this function is disabled. P2-23 and P2-24 are the first group of notch filter.

P2-44	DPH2	Resonance Suppression (Notch Filter) Attenuation Rate (2)		Address: 0258H 0259H
Operational Interface:	Panel / Software	Communication	Related Section:	6.3.6
Default:	0		Control Mode:	ALL
Unit:	-dB		Range:	0 ~ 32 (0: Disable the function of notch filter)
Format:	DEC		Data Size:	16-bit

Settings:  
The second resonance suppression (notch filter) attenuation rate. When this parameter is set to 0, the function of notch filter is disabled.

Note:  
If the value of attenuation rate is set to 5, then, it would be -5 dB.

P2-45	NCF3	Resonance Suppression (Notch Filter) (3)		Address: 025AH 025BH
Operational Interface:	Panel / Software	Communication	Related Section:	6.3.6
Default:	1000		Control Mode:	ALL
Unit:	Hz		Range:	50 ~ 2000
Format:	DEC		Data Size:	16-bit

Settings:  
The third setting value of resonance frequency. If P2-46 is set to 0, this function is disabled. P2-23 and P2-24 are the first group of notch filter.

P2-46	DPH3	Resonance Suppression (Notch Filter) Attenuation Rate (3)		Address: 025CH 025DH
Operational Interface:	Panel / Software	Communication	Related Section:	6.3.6
Default:	0		Control Mode:	ALL
Unit:	-dB		Range:	0 ~ 32
Format:	DEC		Data Size:	16-bit

Settings:  
The third resonance suppression (notch filter) attenuation rate. When this parameter is set to 0, the function of notch filter is disabled. If the value of attenuation rate is set to 5, then, it would be -5 dB.

7

P2-47	ANCF	Auto Resonance Suppression Mode Setting		Address: 025EH 025FH
Operational Interface:	Panel / Software	Communication	Related Section:	-
Default:	1		Control Mode:	ALL
Unit:	-		Range:	0 ~ 2
Format:	DEC		Data Size:	16-bit

## Settings:

- 0: The auto-detection function is disabled.  
 1: Set back to 0 after resonance suppression.  
 2: Continuous resonance suppression.

## Description of Auto Mode Setting:

When it is set to 1: Auto resonance suppression. The value returns to 0 automatically and the point of resonance suppression will be saved automatically when the estimation is stable. If it is unstable, re-power on or set back to 1 for re-estimation.

When it is set to 2: Continuous auto resonance suppression. When the estimation is stable, the point of resonance suppression will be saved automatically. If it is unstable, re-power on for re-estimation.

When switching to mode 0 from mode 2 or 1, the setting of P2-43, P2-44, P2-45 and P2-46 will be saved automatically.

P2-48	ANCL	Resonance Suppression Detection Level		Address: 0260H 0261H
Operational Interface:	Panel / Software	Communication	Related Section:	-
Default:	100		Control Mode:	ALL
Unit:	-		Range:	1 ~ 300 %
Format:	DEC		Data Size:	16-bit

## Settings:

- (The smaller the setting value is, the more sensitive toward the resonance will be.)  
 P2-48↑, resonance sensitiveness↓  
 P2-48↓, resonance sensitiveness↑

P2-49	SJIT	Speed Detection Filter		Address: 0262H 0263H
Operational Interface:	Panel / Software	Communication	Related Section:	-
Default:	0B		Control Mode:	ALL
Unit:	-		Range:	0x00 ~ 0x1F
Format:	HEX		Data Size:	16-bit

## Settings:

The filter of speed estimation

Setting Value	Speed Estimation Bandwidth (Hz)	Setting Value	Speed Estimation Bandwidth (Hz)
00	2500	10	750
01	2250	11	700
02	2100	12	650
03	2000	13	600
04	1800	14	550
05	1600	15	500
06	1500	16	450
07	1400	17	400
08	1300	18	350
09	1200	19	300
0A	1100	1A	250
0B	1000	1B	200

0C	950	1C	175
0D	900	1D	150
0E	850	1E	125
0F	800	1F	100

<b>P2-50~P2-52</b>	<b>Reserved</b>
--------------------	-----------------

<b>P2-53</b>	<b>KPI</b>	<b>Position Integral Compensation</b>		<b>Address: 026AH 026BH</b>
Operational Interface:	Panel / Software	Communication	Related Section:	-
Default:	0		Control Mode:	ALL
Unit:	rad/s		Range:	0 ~ 1023
Format:	DEC		Data Size:	16-bit

Settings:  
When the value of position integral compensation is increased, the position steady-state error is reduced. However, if the setting value is too big, it may easily cause position overshoot and noise.

<b>P5-54~P2-64</b>	<b>Reserved</b>
--------------------	-----------------

<b>P2-65</b>	<b>GBIT</b>	<b>Special-bit Register</b>		<b>Address: 0282H 0283H</b>
Operational Interface:	Panel / Software	Communication	Related Section:	-
Default:	0		Control Mode:	DMCNET / Sz
Unit:	-		Range:	0 ~ 0xFFFF
Format:	-		Data Size:	-

Settings:

Bit 7	Bit 6	Bit 5	Bit 4	Bit 3	Bit 2	Bit 1	Bit 0
-------	-------	-------	-------	-------	-------	-------	-------

Bit 15	Bit 14	Bit 13	Bit 12	Bit 11	Bit 10	Bit 9	Bit 8
--------	--------	--------	--------	--------	--------	-------	-------

- Bit 2 ~ 5, Bit 7 and Bit 14: Reserved (Please set to 0)
- Bit 0 ~ Bit 1: Reserved
- Bit 6: In DMCNET mode, the switch of pulse error protection function (pulse frequency is too high)  
Bit 6 = 0: Enable the function of pulse error protection  
Bit 6 = 1: Disable the function of pulse error protection
- Bit 8: Reserved
- Bit 9: U, V, W wiring cut-off detection  
Bit 9 = 1: Enable U, V, W wiring cut-off detection
- Bit 10: Reserved
- Bit 12: Phase loss detection  
Bit12 = 0: Enable phase loss (AL022) detection  
Bit12 = 1: Disable phase loss (AL022) detection
- Bit13: Encoder output error detection function  
Bit13 = 0: Enable encoder output error (AL018) detection function  
Bit13 = 1: Disable encoder output error (AL018) detection function
- Bit15: Friction compensation mode selection  
Bit15 = 0: If the speed is slower than the value of P1-38, the compensation value remains.  
Bit15 = 1: If the speed is slower than the value of P1-38, the compensation value becomes 0.

7

P2-66	GBIT2	Special-bit Register 2		Address: 0284H 0285H
Operational Interface:	Panel / Software	Communication	Related Section:	-
Default:	10		Control Mode:	DMCNET / Sz
Unit:	-		Range:	0 ~ 0x083F
Format:	HEX		Data Size:	16-bit

Settings:

Special-bit Register 2

Bit 7	Bit 6	Bit 5	Bit 4	Bit 3	Bit 2	Bit 1	Bit 0
-------	-------	-------	-------	-------	-------	-------	-------

Bit 15	Bit 14	Bit 13	Bit 12	Bit 11	Bit 10	Bit 9	Bit 8
--------	--------	--------	--------	--------	--------	-------	-------

- Bit 0 ~ Bit 1: Reserved
- Bit 2: Cancel latch function of low-voltage error  
0: Latch function of low-voltage error: the error will not be cleared automatically  
1: Cancel latch function of low-voltage error: the error will be cleared automatically.
- Bit 3: Reserved
- Bit 4: Cancel the detection of AL044  
0: AL044 will occur  
1: AL044 will be ignored
- Bit 6 ~ Bit 8: Reserved
- Bit 9: When AL003 occurs, switch on DO.ALM or DO.WARN.  
0: When AL003 occurs, switch on DO.WARN.  
1: When AL003 occurs, switch on DO.ALM.
- Bit 10 ~ Bit 15: Reserved

P2-67	JSL	The Stable Level of Inertia Estimation		Address: 0286H 0287H
Operational Interface:	Panel / Software	Communication	Related Section:	-
Default:	1.5	15	Control Mode:	ALL
Unit:	1 times	0.1 times	Data Size:	16-bit
Range:	0 ~ 200.0	0 ~ 2000	-	-
Format:	One decimal	DEC	-	-
Example:	1.5 = 1.5 times	15 = 1.5 times	-	-

Settings:

In semi-auto mode, if the value of inertia estimation is smaller than the value of P2-67 and the status remains for a while, the system will regard the inertia estimation as completed.

<b>P2-68</b>	<b>Reserved</b>
--------------	-----------------

P2-69●	ABS	Absolute Encoder Setting		Address: 028AH 028BH
Operational Interface:	Panel / Software	Communication	Related Section:	-
Default:	0		Control Mode:	ALL
Unit:	-		Range:	0 ~ 1
Format:	HEX		Data Size:	16-bit

Settings:

- 0: Incremental mode. Servo motor with absolute encoder can be operated as the one with incremental encoder.
- 1: Absolute mode. (This setting is only available for servo motors with absolute encoder. When a motor with incremental encoder is connected, AL069 will occur.)

Note:

This parameter is effective only after the servo drive is re-powered on.

P2-70	MRS	Read Data Format Selection			Address: 028CH 028DH
Operational Interface:	Panel / Software	Communication	Related Section:	-	
Default:	0		Control Mode:	ALL	
Unit:	-		Range:	0x00~0x07	
Format:	HEX		Data Size:	16-bit	

Settings:

Bit 7	Bit 6	Bit 5	Bit 4	Bit 3	Bit 2	Bit 1	Bit 0
-------	-------	-------	-------	-------	-------	-------	-------

Bit 15	Bit 14	Bit 13	Bit 12	Bit 11	Bit 10	Bit 9	Bit 8
--------	--------	--------	--------	--------	--------	-------	-------

Bit 0: Data unit setting of digital input / output (DI / DO); 1: pulse, 0: PUU.  
 Bit 1: Communication data unit setting; 1: pulse, 0: PUU.  
 Bit 2: Overflow warning; 1: No overflow warning; 0: Overflow warning, AL289 (PUU) and AL062 (pulse).  
 Bit 3 ~ Bit 15: Reserved. Must be set to 0.

P2-71■	CAP	Absolute Position Homing			Address: 028EH 028FH
Operational Interface:	Panel / Software	Communication	Related Section:	-	
Default:	0		Control Mode:	ALL	
Unit:	-		Range:	0 ~ 1	
Format:	HEX		Data Size:	16-bit	

Settings:

When P2-71 is set to 1, the current position will be set as home position. This function can be enabled only when parameter P2-08 is set to 271.

P2-72~P2-79	Reserved
-------------	----------

7

### P3-xx Communication Parameters

P3-00●	ADR	Address Setting			Address: 0300H 0301H
Operational Interface:	Panel / Software	Communication	Related Section:	-	
Default:	01		Control Mode:	ALL	
Unit:	-		Range:	0x01 ~ 0x7F	
Format:	HEX		Data Size:	16-bit	

Settings:

The communication address setting is divided into Y and X (hexadecimal):

-	0	0	Y	X
Range	-	-	0 ~ 7	0 ~ F

When using RS-232 to communicate, one servo drive can only set one address. Duplicate address setting will cause abnormal communication.

This address represents the absolute address of the servo drive in the communication network which is applicable to RS-232 and DMCNET bus.

When the communication address setting of MODBUS is set to 0xFF, the servo drive will automatically reply and receive data regardless of the address. However, P3-00 cannot be set to 0xFF.

P3-01	BRT	Transmission Speed			Address: 0302H 0303H
Operational Interface:	Panel / Software	Communication	Related Section:	-	
Default:	3203		Control Mode:	ALL	
Unit:	Bps		Range:	0x000 ~ 0x3405	
Format:	HEX		Data Size:	16-bit	

Settings:

The setting of transmission speed is divided into Z, Y and X (hexadecimal):

-	0	Z	Y	X
Communication Port	-	DMCNET	-	RS-232
Range	0	0 ~ 4	0	0 ~ 5

- Definition of setting value X

0: 4800	1: 9600	2: 19200
3: 38400	4: 57600	5: 115200

- Definition of setting value Z

0: 125 Kbit/s	1: 250 Kbit/s	2: 500 Kbit/s
3: 750 Kbit/s	4: 1.0 Mbit/s	-

Note:

If this parameter is set via DMCNET, only Z can be set and the others remain.

P3-02	PTL	Communication Protocol			Address: 0304H 0305H
Operational Interface:	Panel / Software	Communication	Related Section:	-	
Default:	6		Control Mode:	ALL	
Unit:	Bps		Range:	0 ~ 8	
Format:	HEX		Data Size:	16-bit	

Settings:

The definition of the setting value is as the followings:

0: 7, N, 2(MODBUS, ASCII)	1: 7, E, 1(MODBUS, ASCII)	2: 7, O, 1(MODBUS, ASCII)
3: 8, N, 2(MODBUS, ASCII)	4: 8, E, 1(MODBUS, ASCII)	5: 8, O, 1(MODBUS, ASCII)

6: 8, N, 2(MODBUS, RTU)	7: 8, E, 1(MODBUS, RTU)	8: 8, O, 1(MODBUS, RUT)
-------------------------	-------------------------	-------------------------

P3-03	FLT	Communication Error Disposal		Address: 0306H 0307H
Operational Interface:	Panel / Software	Communication	Related Section:	-
Default:	0		Control Mode:	ALL
Unit:	-		Range:	0 ~ 1
Format:	HEX		Data Size:	16-bit

Settings:

The definition of the setting value is as the followings:

0: Warning displays and motor keeps running

1: Warning displays and motor decelerates to stop (The deceleration time can be set via P5-03.B)

P3-04	CWD	Communication Timeout		Address: 0308H 0309H
Operational Interface:	Panel / Software	Communication	Related Section:	-
Default:	0		Control Mode:	ALL
Unit:	sec		Range:	0 ~ 20
Format:	DEC		Data Size:	16-bit

Settings:

If the setting value is not 0, the communication timeout function is enabled immediately. If it is set to 0, this function will be disabled.

P3-05	CMM	Communication Mechanism		Address: 030AH 030BH
Operational Interface:	Panel / Software	Communication	Related Section:	-
Default:	0		Control Mode:	ALL
Unit:	-		Range:	0x00 ~ 0x01
Format:	HEX		Data Size:	16-bit

Settings:

Communication interface selection (one or more than one communication)

Communication Interface: 0: RS-232

P3-06■	SDI	Control Switch of Digital Input (DI)		Address: 030CH 030DH
Operational Interface:	Panel / Software	Communication	Related Section:	-
Default:	0		Control Mode:	ALL
Unit:	-		Range:	0x0000 ~ 0x3FFF
Format:	HEX		Data Size:	16-bit

Settings:

Control switch of DI source. Each bit of this parameter decides one input source of DI signal:

Bit0 ~ Bit4 correspond to DI1 ~ DI5.

The setting of bit is as the followings:

0: The input status is controlled by the external hardware terminal.

1: The input status is controlled by P4-07.

For functional planning of digital input, please refer to:

DI1 ~ DI5: P2-10 ~ P2-14

7

P3-07	CDT	Communication Response Delay Time		Address: 030EH 030FH
Operational Interface:	Panel / Software	Communication	Related Section:	-
Default:	0		Control Mode:	ALL
Unit:	0.5 ms		Range:	0 ~ 1000
Format:	DEC		Data Size:	16-bit

Settings:

Delay the time of communication response from servo drive to controller.

P3-08	MNS	Monitor Mode		Address: 0310H 0311H
Operational Interface:	Panel / Software	Communication	Related Section:	-
Default:	0		Control Mode:	ALL
Unit:	-		Range:	Shown as below
Format:	HEX		Data Size:	16-bit

Settings:

The setting of monitor mode is divided into L and H (hexadecimal):

Item	-	-	L	H
Function	-	-	Low-speed monitoring time	Monitor Mode
Range	0	0	0 ~ F	0 ~ 3

The status of this axis or multi-axis can be monitored by USB. The definition of the setting value is as follows:

- The definition of setting value H

0: Disable the monitor function

1: Low-speed monitoring. The sampling time is set by L and can monitor 4 channels.

2: High-speed monitoring. The sampling frequency is 2K and can monitor 4 channels.

3: High-speed monitoring. The sampling frequency is 4K and can only monitor 2 channels.

- L: Sampling time of low-speed monitoring. (Unit: ms)

It means the axial status will be sent via USB every L ms. So the controller can monitor the axial status. Each monitoring message includes data of 4 channels (16 bit x 4). If L is set to 0, this function is disabled. L is enabled when H is set to 1.

P3-09	SYC	DMCNET Synchronize Setting		Address: 0312H 0313H
Operational Interface:	Panel / Software	Communication	Related Section:	-
Default:	3511		Control Mode:	DMCNET
Unit:	-		Range:	Shown as below
Format:	HEX		Data Size:	16-bit

Settings:

The synchronization setting of DMCNET is divided into E, T, D and M (hexadecimal):

Item	E	T	D	M
Function	Range of Synchronous Error	Target Value	Deadband	Adjusting Amount
Range	1 ~ 9	0 ~ 9	0 ~ F	1 ~ F

The DMCNET slave synchronizes with the master via SYNC. See as the followings:

M: If the slave needs to synchronize with the master, correcting the clock is a must. This parameter sets the maximum correction value per time. (Unit: usec)

D: Set the size of deadband (Unit: usec). If the deviation between the SYNC reaching time and the target value does not exceed the deadband, correction is not needed.

T: SYNC arrival time. The standard value is 500 usec but it might be different from the target value. Thus, the buffer is necessary.

Target value = 400 + 10 x T

For instance, if T = 5, the target value will be 450.

E: If the deviation between SYNC reaching time and the target value is smaller than the range, it means the synchronization is successful. (Unit: 10 usec)

<b>P3-10</b>	<b>CANEN</b>	<b>DMCNET Protocol Setting</b>		<b>Address: 0314H 0315H</b>
Operational Interface:	Panel / Software	Communication	Related Section:	-
Default:	1		Control Mode:	DMCNET
Unit:	-		Range:	Shown as below
Format:	HEX		Data Size:	16-bit

Settings:

DMCNET synchronization setting is divided into X, Y and Z (hexadecimal):

Item	Z	Y	X
Function	Undefined	To servo off if DMCNET bus error occurs.	-
Range	0 ~ F	0 ~ 1	1

Definition is as the followings:

X: Normally set to 1.

Y: 0: The motor keeps running when communication error occurs; 1: Servo off when communication error occurs

Z: Undefined

<b>P3-11</b>	<b>CANOP</b>	<b>DMCNET Selection</b>		<b>Address: 0316H 0317H</b>
Operational Interface:	Panel / Software	Communication	Related Section:	-
Default:	0		Control Mode:	DMCNET
Unit:	-		Range:	Shown as below
Format:	HEX		Data Size:	16-bit

Settings:

DMCNET synchronization setting is divided into X, Y, Z and U. (hexadecimal):

Item	U	Z	Y	X
Function	Undefined	Undefined	Undefined	Whether the parameter is saved into EEPROM.
Range	0 ~ 1	0 ~ F	0 ~ F	0 ~ 1

Definition is as the followings:

X: 1: When writing parameters by PDO, parameters will be saved to EEPROM.

0: When writing parameters by PDO, parameters will not be saved to EEPROM.

Y, Z, U: Undefined

Note:

If X is set to 1 and parameters are written by PDO continuously, it will shorten the lifetime of EEPROM.

<b>P3-12</b>	<b>QSTPO</b>	<b>DMCNET Support Setting</b>		<b>Address: 0318H 0319H</b>
Operational Interface:	Panel / Software	Communication	Related Section:	-
Default:	0		Control Mode:	DMCNET
Unit:	-		Range:	0x0000 ~ 0x0111
Format:	HEX		Data Size:	16-bit

Settings:

Item	U	Z
Function	None	DMCNET parameter value will be loaded in.
Range	None	0~1

The following table shows P parameters and its corresponding DMCNET parameters. The setting of Z (hexadecimal) can determine if it should be modified.

This function is applicable in DMCNET mode: 0xB mode selection (P1-01 = b)

Z: P parameters will be overwritten by DMCNET parameters.

Z = 0: When re-servo on the servo drive or reset the communication, P parameters that mentioned in the following table will load in the value of DMCNET parameters.

Z = 1: When re-servo on the servo drive or reset the communication, P parameters that mentioned in the following table will remain its original setting. The value of DMCNET parameters will not be loaded in.

#### DMCNET Parameter:

DMCNET Parameter		P Parameter	
Parameter	Default	Parameter	Default
P1-32 <sub>DMCNET</sub>	0	P1-32	P1-32.Y = 0, Dynamic break enable P1-32.Y = 1, Dynamic break disable
P2-35 <sub>DMCNET</sub>	3840000	P2-35	3840000
P1-47 <sub>DMCNET</sub>	100 (0.1 rpm)	P1-47	10 (rpm)
P1-49 <sub>DMCNET</sub>	0	P1-49	0
P1-38 <sub>DMCNET</sub>	100	P1-38	100
P1-44 <sub>DMCNET</sub>	1:1	P1-44/P1-45	128:10
P1-45 <sub>DMCNET</sub>			

**P3-13 ~ P3-16**

**Reserved**

### P4-xx Diagnosis Parameters

7

<b>P4-00★</b>	<b>ASH1</b>	<b>Fault Record (N)</b>			<b>Address: 0400H 0401H</b>
Operational Interface:	Panel / Software	Communication	Related Section:	4.4.1	
Default:	0		Control Mode:	ALL	
Unit:	-		Range:	-	
Format:	HEX		Data Size:	32-bit	

Settings:  
 The last abnormal status record  
 Low word: LXXXX: Display ALM number.  
 High word: hYYYY: Display the error code which corresponds to DMCNET.

<b>P4-01★</b>	<b>ASH2</b>	<b>Fault Record (N-1)</b>			<b>Address: 0402H 0403H</b>
Operational Interface:	Panel / Software	Communication	Related Section:	4.4.1	
Default:	0		Control Mode:	ALL	
Unit:	-		Range:	-	
Format:	HEX		Data Size:	32-bit	

Settings:  
 The last second abnormal status record  
 Low word: LXXXX: Display ALM number.  
 High word: hYYYY: Display the error code which corresponds to DMCNET.

<b>P4-02★</b>	<b>ASH3</b>	<b>Fault Record (N-2)</b>			<b>Address: 0404H 0405H</b>
Operational Interface:	Panel / Software	Communication	Related Section:	4.4.1	
Default:	0		Control Mode:	ALL	
Unit:	-		Range:	-	
Format:	HEX		Data Size:	32-bit	

Settings:  
 The last third abnormal status record  
 Low word: LXXXX: Display ALM number.  
 High word: hYYYY: Display the error code which corresponds to DMCNET.

<b>P4-03★</b>	<b>ASH4</b>	<b>Fault Record (N-3)</b>			<b>Address: 0406H 0407H</b>
Operational Interface:	Panel / Software	Communication	Related Section:	4.4.1	
Default:	0		Control Mode:	ALL	
Unit:	-		Range:	-	
Format:	HEX		Data Size:	32-bit	

Settings:  
 The last fourth abnormal status record  
 Low word: LXXXX: Display ALM number.  
 High word: hYYYY: Display the error code corresponds to DMCNET.

<b>P4-04★</b>	<b>ASH5</b>	<b>Fault Record (N-4)</b>			<b>Address: 0408H 0409H</b>
Operational Interface:	Panel / Software	Communication	Related Section:	4.4.1	
Default:	0		Control Mode:	ALL	
Unit:	-		Range:	-	
Format:	HEX		Data Size:	32-bit	

Settings:  
 The last fifth abnormal status record  
 Low word: LXXXX: Display ALM number.  
 High word: hYYYY: Display the error code which corresponds to DMCNET.

7

P4-05	JOG	Servo Motor Jog Control		Address: 040AH 040BH
Operational Interface:	Panel / Software	Communication	Related Section:	4.4.2
Default:	20		Control Mode:	ALL
Unit:	r/min		Range:	0 ~ 5000
Format:	DEC		Data Size:	16-bit

Settings:

Two control methods are as follows:

1. Operation Test

After the JOG speed is set by P4-05 via the panel, the panel will display the symbol of JOG.

Pressing the UP key can control JOG operation in positive direction; pressing the DOWN key can control JOG operation in negative direction. Stop pressing to stop the JOG operation. If there is any error in this setting, then the motor cannot operate. The maximum JOG speed is the maximum speed of the servo motor.

2. Communication Control

1 ~ 5000: JOG speed	4998: JOG operation in CCW direction
4999: JOG operation in CW direction	0: Stop operation

Note:

When writing via communication, if the frequency is high, please set P2-30 to 5.

P4-06 ▲■	FOT	Digital Output Register (Readable and Writable)		Address: 040CH 040DH
Operational Interface:	Panel / Software	Communication	Related Section:	4.4.3
Default:	0		Control Mode:	ALL
Unit:	-		Range:	0 ~ 0xFF
Format:	HEX		Data Size:	16-bit

Settings:

bit 00: correspond to DO code=0x30	bit 08: correspond to DO code=0x38
bit 01: correspond to DO code=0x31	bit 09: correspond to DO code=0x39
bit 02: correspond to DO code=0x32	bit 10: correspond to DO code=0x3A
bit 03: correspond to DO code=0x33	bit 11: correspond to DO code=0x3B
bit 04: correspond to DO code=0x34	bit 12: correspond to DO code=0x3C
bit 05: correspond to DO code=0x35	bit 13: correspond to DO code=0x3D
bit 06: correspond to DO code=0x36	bit 14: correspond to DO code=0x3E
bit 07: correspond to DO code=0x37	bit 15: correspond to DO code=0x3F

If P2-18 is set to 0x0130, then DO#1 represents the bit 0 status of P4-06. DO code (0x30~0x3F) can be set via communication DO, and then write into P4-06.

P4-07 ■	ITST	Multi-function of Digital Input		Address: 040EH 040FH
Operational Interface:	Panel / Software	Communication	Related Section:	4.4.4, 8.2
Default:	0		Control Mode:	ALL
Unit:	-		Range:	0 ~ 3FFF
Format:	HEX		Data Size:	16-bit

Settings:

The DI input signal can come from external terminal (DI1 ~ DI5) or software SDI1 ~ 5 (Bit 0 ~ 4 of P4-07) and is determined by P3-06. If the corresponding bit of P3-06 is 1, it means the source is software SDI (P4-07); if the corresponding bit is 0, then the source is hardware DI. See the following graph:

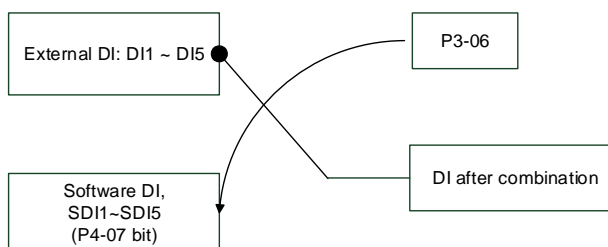

Read parameters: shows the DI status after combination

Write parameters: writes the software SDI status (The function of this parameter is the same whether it is written via panel or communication.)

Example: The value of reading P4-07 is 0x0011, which means DI1 and DI5 are ON; the value of writing P4-07 is 0x0011, which means software SDI1 and SDI5 are ON

Please refer to P2-10 ~ P2-14 for function program of digital input pin DI (DI1~DI5).

P4-08★	PKEY	Input Status of the Drive Keypad (Read-only)		Address: 0410H 0411H
Operational Interface:	Panel / Software	Communication	Related Section:	-
Default:	-		Control Mode:	ALL
Unit:	-		Range:	(Read-only)
Format:	HEX		Data Size:	16-bit

Settings:

The aim is to check if the five keys MODE, UP, DOWN, SHIFT and SET can work normally.

P4-09★	PKEY	Digital Output Status (Read-only)		Address: 0412H 0413H
Operational Interface:	Panel / Software	Communication	Related Section:	4.4.5
Default:	-		Control Mode:	ALL
Unit:	-		Range:	0 ~ 0x1F
Format:	HEX		Data Size:	16-bit

Settings:

There is no difference between reading via panel or communication.

P4-10■	CEN	Adjustment Selection		Address: 0414H 0415H
Operational Interface:	Panel / Software	Communication	Related Section:	-
Default:	0		Control Mode:	ALL
Unit:	-		Range:	0 ~ 6
Format:	DEC		Data Size:	16-bit

Settings:

0: Reserved	4: Execute the adjustment of current detector (W phase) hardware offset
1: Reserved	5: Execute the adjustment of 1 ~ 4 hardware offset
2: Reserved	6: Execute the adjustment of IGBT ADC
3: Execute the adjustment of current detector (V phase) hardware offset	-

Note:

The adjustment function needs to be enabled by the setting of parameter P2-08. When adjusting, the external wiring which connects to torque needs to be removed completely and must be in Servo Off status.

<b>P4-11~P4-14</b>	<b>Reserved</b>
--------------------	-----------------

P4-15	COF1	Current Detector (V1 Phase) Offset Adjustment		Address: 041EH 041FH
Operational Interface:	Panel / Software	Communication	Related Section:	-
Default:	Factory default		Control Mode:	ALL
Unit:	-		Range:	0 ~ 32767
Format:	DEC		Data Size:	16-bit

Settings:

Manually adjust the hardware offset. The adjustment function needs to be enabled by the setting of parameter P2-08. It is not suggested to adjust the auxiliary adjustment. This parameter cannot be reset.

7

P4-16	COF2	Current Detector (V2 Phase) Offset Adjustment		Address: 0420H 0421H
Operational Interface:	Panel / Software	Communication	Related Section:	-
Default:	Factory default		Control Mode:	ALL
Unit:	-		Range:	0 ~ 32767
Format:	DEC		Data Size:	16-bit

Settings:  
Manually adjust the hardware offset. The adjustment function needs to be enabled by the setting of parameter P2-08. It is not suggested to adjust the auxiliary adjustment. This parameter cannot be reset.

P4-17	COF3	Current Detector (W1 Phase) Offset Adjustment		Address: 0422H 0423H
Operational Interface:	Panel / Software	Communication	Related Section:	-
Default:	Factory default		Control Mode:	ALL
Unit:	-		Range:	0 ~ 32767
Format:	DEC		Data Size:	16-bit

Settings:  
Manually adjust the hardware offset. The adjustment function needs to be enabled by the setting of parameter P2-08. It is not suggested to adjust the auxiliary adjustment. This parameter cannot be reset.

P4-18	COF4	Current Detector (W2 Phase) Offset Adjustment		Address: 0424H 0425H
Operational Interface:	Panel / Software	Communication	Related Section:	-
Default:	Factory default		Control Mode:	ALL
Unit:	-		Range:	0 ~ 32767
Format:	DEC		Data Size:	16-bit

Settings:  
Manually adjust the hardware offset. The adjustment function needs to be enabled by the setting of parameter P2-08. It is not suggested to adjust the auxiliary adjustment. This parameter cannot be reset.

P4-19	TIGB	IGBT NTC Adjustment Detection Level (cannot reset)		Address: 0426H 0427H
Operational Interface:	Panel / Software	Communication	Related Section:	-
Default:	Factory default		Control Mode:	ALL
Unit:	-		Range:	1 ~ 4
Format:	DEC		Data Size:	16-bit

Settings:  
Please cool down the drive to 25°C when adjusting.

<b>P4-20-P4-23</b>	<b>Reserved</b>			
--------------------	-----------------	--	--	--

P4-24	LVL	Level of Under Voltage Error		Address: 0430H 0431H
Operational Interface:	Panel / Software	Communication	Related Section:	-
Default:	160		Control Mode:	ALL
Unit:	V (rms)		Range:	140 ~ 190
Format:	DEC		Data Size:	16-bit

Settings:  
When the voltage of DC BUS is lower than  $P4-24 * \sqrt{2}$ , the under voltage error occurs.

### P5-xx Motion Setting Parameters

7

<b>P5-00 ~ P5-02</b>	<b>Reserved</b>		
----------------------	-----------------	--	--

<b>P5-03</b>	<b>PDEC</b>	<b>Deceleration Time of Auto Protection</b>		<b>Address: 0506H 0507H</b>
Operational Interface:	Panel / Software	Communication	Related Section:	-
Default:	E0EFEFFF		Control Mode:	ALL
Unit:	-		Range:	0x00000000 ~ 0xF0FFFFFF
Format:	HEX		Data Size:	32-bit

**Settings:**

The parameter setting is divided into D, C, B, A, W, Z, Y and X (hexadecimal), including:

1. Deceleration time when auto-protection function is activated: OVF, CTO (communication timeout AL020), SPL, SNL, PL and NL.
2. Deceleration time of stop command: STP

Item	D	C	B	A	W	Z	Y	X
Function	STP	Reserved	CTO	OVF	SNL	SPL	N	PL
Range	0 ~ F	-	0 ~ F	0 ~ F	0 ~ F	0 ~ F	0 ~ F	0 ~ F

0 ~ F is used for indexing the deceleration time of P5 - 20 ~ P5 - 35. For example: If X is set to A, then the deceleration time of PL is determined by P5-30.

<b>P5-04 ~ P5-07</b>	<b>Reserved</b>		
----------------------	-----------------	--	--

<b>P5-08</b>	<b>SWLP</b>	<b>Forward Software Limit</b>		<b>Address: 0510H 0511H</b>
Operational Interface:	Panel / Software	Communication	Related Section:	-
Default:	2147483647		Control Mode:	DMCNET
Unit:	PUU		Range:	-2147483648 ~ +2147483647
Format:	DEC		Data Size:	32-bit

**Settings:**

In DMCNET mode, if the motor rotates in forward direction and its command position exceeds the setting value of P5-08, it will trigger AL283.

<b>P5-09</b>	<b>SWLN</b>	<b>Reverse Software Limit</b>		<b>Address: 0512H 0513H</b>
Operational Interface:	Panel / Software	Communication	Related Section:	-
Default:	-2147483648		Control Mode:	DMCNET
Unit:	PUU		Range:	-2147483648 ~ +2147483647
Format:	DEC		Data Size:	32-bit

**Settings:**

In DMCNET mode, if the motor rotates in reverse direction and its command position exceeds the setting value of P5-09, it will trigger AL285.

<b>P5-10~P5-19</b>	<b>Reserved</b>		
--------------------	-----------------	--	--

7

P5-20	AC0	Acceleration / Deceleration Time (Number #0)		Address: 0528H 0529H
Operational Interface:	Panel / Software	Communication	Related Section:	-
Default:	200		Control Mode:	DMCNET
Unit:	ms		Range:	1 ~ 65500
Format:	DEC		Data Size:	16-bit

Settings:

The setting time of acceleration / deceleration in DMCNET mode, which is the time required to accelerate from 0 to 3000 r/min.

P5-21	AC1	Acceleration / Deceleration Time (Number #1)		Address: 052AH 052BH
Operational Interface:	Panel / Software	Communication	Related Section:	-
Default:	300		Control Mode:	DMCNET
Unit:	ms		Range:	1 ~ 65500
Format:	DEC		Data Size:	16-bit

Settings:

Please refer to P5-20 for the setting of acceleration / deceleration time in DMCNET mode.

P5-22	AC2	Acceleration / Deceleration Time (Number #2)		Address: 052CH 052DH
Operational Interface:	Panel / Software	Communication	Related Section:	-
Default:	500		Control Mode:	DMCNET
Unit:	ms		Range:	1 ~ 65500
Format:	DEC		Data Size:	16-bit

Settings:

Please refer to P5-20 for the setting of acceleration / deceleration time in DMCNET mode.

P5-23	AC3	Acceleration / Deceleration Time (Number #3)		Address: 052EH 052FH
Operational Interface:	Panel / Software	Communication	Related Section:	-
Default:	600		Control Mode:	DMCNET
Unit:	ms		Range:	1 ~ 65500
Format:	DEC		Data Size:	16-bit

Settings:

Please refer to P5-20 for the setting of acceleration / deceleration time in DMCNET mode.

P5-24	AC4	Acceleration / Deceleration Time (Number #4)		Address: 0530H 0531H
Operational Interface:	Panel / Software	Communication	Related Section:	-
Default:	800		Control Mode:	DMCNET
Unit:	ms		Range:	1 ~ 65500
Format:	DEC		Data Size:	16-bit

Settings:

Please refer to P5-20 for the setting of acceleration / deceleration time in DMCNET mode.

P5-25	AC5	Acceleration / Deceleration Time (Number #5)		Address: 0532H 0533H
Operational Interface:	Panel / Software	Communication	Related Section:	-
Default:	900		Control Mode:	DMCNET
Unit:	ms		Range:	1 ~ 65500
Format:	DEC		Data Size:	16-bit

Settings:

Please refer to P5-20 for the setting of acceleration / deceleration time in DMCNET mode.

P5-26	AC6	Acceleration / Deceleration Time (Number #6)		Address: 0534H 0535H
Operational Interface:	Panel / Software	Communication	Related Section:	-
Default:	1000		Control Mode:	DMCNET
Unit:	ms		Range:	1 ~ 65500
Format:	DEC		Data Size:	16-bit

Settings:

Please refer to P5-20 for the setting of acceleration / deceleration time in DMCNET mode.

P5-27	AC7	Acceleration / Deceleration Time (Number #7)		Address: 0536H 0537H
Operational Interface:	Panel / Software	Communication	Related Section:	-
Default:	1200		Control Mode:	DMCNET
Unit:	ms		Range:	1 ~ 65500
Format:	DEC		Data Size:	16-bit

Settings:

Please refer to P5-20 for the setting of acceleration / deceleration time in DMCNET mode.

P5-28	AC8	Acceleration / Deceleration Time (Number #8)		Address: 0538H 0539H
Operational Interface:	Panel / Software	Communication	Related Section:	-
Default:	1500		Control Mode:	DMCNET
Unit:	ms		Range:	1 ~ 65500
Format:	DEC		Data Size:	16-bit

Settings:

Please refer to P5-20 for the setting of acceleration / deceleration time in DMCNET mode.

P5-29	AC9	Acceleration / Deceleration Time (Number #9)		Address: 053AH 053BH
Operational Interface:	Panel / Software	Communication	Related Section:	-
Default:	2000		Control Mode:	DMCNET
Unit:	ms		Range:	1 ~ 65500
Format:	DEC		Data Size:	16-bit

Settings:

Please refer to P5-20 for the setting of acceleration / deceleration time in DMCNET mode.

P5-30	AC10	Acceleration / Deceleration Time (Number #10)		Address: 053CH 053DH
Operational Interface:	Panel / Software	Communication	Related Section:	-
Default:	2500		Control Mode:	DMCNET
Unit:	ms		Range:	1 ~ 65500
Format:	DEC		Data Size:	16-bit

Settings:

Please refer to P5-20 for the setting of acceleration / deceleration time in DMCNET mode.

7

7

P5-31	AC11	Acceleration / Deceleration Time (Number #11)		Address: 053EH 053FH
Operational Interface:	Panel / Software	Communication	Related Section:	-
Default:	3000		Control Mode:	DMCNET
Unit:	ms		Range:	1 ~ 65500
Format:	DEC		Data Size:	16-bit

Settings:  
Please refer to P5-20 for the setting of acceleration / deceleration time in DMCNET mode.

P5-32	AC12	Acceleration / Deceleration Time (Number #12)		Address: 0540H 0541H
Operational Interface:	Panel / Software	Communication	Related Section:	-
Default:	5000		Control Mode:	DMCNET
Unit:	ms		Range:	1 ~ 65500
Format:	DEC		Data Size:	16-bit

Settings:  
Please refer to P5-20 for the setting of acceleration / deceleration time in DMCNET mode.

P5-33	AC13	Acceleration / Deceleration Time (Number #13)		Address: 0542H 0543H
Operational Interface:	Panel / Software	Communication	Related Section:	-
Default:	8000		Control Mode:	DMCNET
Unit:	ms		Range:	1 ~ 65500
Format:	DEC		Data Size:	16-bit

Settings:  
Please refer to P5-20 for the setting of acceleration / deceleration time in DMCNET mode.

P5-34	AC14	Acceleration / Deceleration Time (Number #14)		Address: 0544H 0545H
Operational Interface:	Panel / Software	Communication	Related Section:	-
Default:	50		Control Mode:	DMCNET
Unit:	ms		Range:	1 ~ 1500
Format:	DEC		Data Size:	16-bit

Settings:  
The default value of this parameter is smaller (short deceleration time) and it is used for deceleration time setting of auto protection.

P5-35	AC15	Acceleration / Deceleration Time (Number #15)		Address: 0546H 0547H
Operational Interface:	Panel / Software	Communication	Related Section:	-
Default:	30		Control Mode:	DMCNET
Unit:	ms		Range:	1 ~ 1200
Format:	DEC		Data Size:	16-bit

Settings:  
The default value of this parameter is smaller (short deceleration time) and it is used for deceleration time setting of auto protection.

Note:  
The default value of this parameter is smaller, which can be used in high-speed deceleration.

**Table 7.1 Function Description of Digital Input (DI)**

Setting Value: 0x02									
DI Name	Function Description of Digital Input (DI)							Trigger Method	Control Mode
ARST	After the cause of alarm has been removed, when this DI is ON, it means the alarm shown on the servo drive has been cleared.							Rising edge triggered	ALL

Setting Value: 0x03									
DI Name	Function Description of Digital Input (DI)							Trigger Method	Control Mode
GAINUP	In speed and position modes, when this DI is ON (P2-27 should be set to 1), the gain switches to the one multiplies the switching rate.							Level triggered	DMCNET, Sz

Setting Value: 0x14, 0x15										
DI Name	Function Description of Digital Input (DI)							Trigger Method	Control Mode	
SPD0 SPD1	Internal Speed Command Selection (1~4)									
	Speed Command Number	DI Signal of CN1		Command Source			Content	Range	Level triggered	Sz
		SPD1	SPD0							
	S1	0	0	Mode	Sz	N/A	Speed command is 0	0		
	S2	0	1	Internal Register Parameter			P1-09	+/- 5000 r/min		
S3	1	0	P1-10				+/- 5000 r/min			
S4	1	1	P1-11	+/- 5000 r/min						

Setting Value: 0x16, 0x17										
DI Name	Function Description of Digital Input (DI)							Trigger Method	Control Mode	
TCM0 TCM1	Internal Torque Command Selection (1~4)									
	Torque Command Number	DI Signal of CN1		Command Source			Content	Range	Level triggered	Tz
		TCM1	TCM0							
	T1	0	0	Mode	Tz	N/A	Torque command is 0	0		
	T2	0	1	Internal Register Parameter			P1-12	+/- 300 %		
T3	1	0	P1-13				+/- 300 %			
T4	1	1	P1-14	+/- 300 %						

Setting Value: 0x21									
DI Name	Function Description of Digital Input (DI)							Trigger Method	Control Mode
EMGS	When this DI is ON, the motor stops urgently.							Level triggered	ALL

Setting Value: 0x22									
DI Name	Function Description of Digital Input (DI)							Trigger Method	Control Mode
NL (CWL)	Reverse inhibit limit (contact b)							Level triggered	ALL

7

<b>Setting Value: 0x23</b>			
DI Name	Function Description of Digital Input (DI)	Trigger Method	Control Mode
PL (CCWL)	Forward inhibit limit (contact b)	Level triggered	ALL

<b>Setting Value: 0x24</b>			
DI Name	Function Description of Digital Input (DI)	Trigger Method	Control Mode
ORGP	In DMCNET mode, if this DI is ON during the process of homing, the servo will regard the current position as the homing origin (Please refer to the setting of parameter P5-04)	Rising / Falling edge triggered	DMCNET

7

**Table 7.2 Function Description of Digital Output (DO)**

Setting Value: 0x01			
DO Name	Function Description of Digital Output (DO)	Trigger Method	Control Mode
SRDY	When the control and main circuit power is applied to the drive, this DO is ON if no alarm occurs.	Level triggered	ALL
Setting Value: 0x02			
DO Name	Function Description of Digital Output (DO)	Trigger Method	Control Mode
SON	<p>When the servo is ON, this DO is ON if no alarm occurs.</p> <p>Time difference between DO.SRDY and DO.SON when servo on right after connecting to the power.</p> <p>DO. SRDY OFF ON</p> <p>DO. SON OFF ON</p> <p>Approx. 300 ns</p>	Level triggered	ALL
Setting Value: 0x03			
DO Name	Function Description of Digital Output (DO)	Trigger Method	Control Mode
ZSPD	When the motor speed is slower than the setting value of zero speed (P1-38), this DO is ON.	Level triggered	ALL
Setting Value: 0x04			
DO Name	Function Description of Digital Output (DO)	Trigger Method	Control Mode
TSPD	When the motor speed is faster than the target speed (P1-39), this DO is ON.	Level triggered	ALL
Setting Value: 0x05			
DO Name	Function Description of Digital Output (DO)	Trigger Method	Control Mode
TPOS	When the deviation of pulse number is smaller than the position range (P1-54), this DO is ON.	Level triggered	DMCNET
Setting Value: 0x06			
DO Name	Function Description of Digital Output (DO)	Trigger Method	Control Mode
TQL	When it is in torque limit, this DO is ON.	Level triggered	DMCNET, Sz
Setting Value: 0x07			
DO Name	Function Description of Digital Output (DO)	Trigger Method	Control Mode
ALRM	When an alarm occurs, this DO is ON. (Except forward / reverse limit, communication error, under voltage and abnormal fan)	Level triggered	ALL
Setting Value: 0x08			
DO Name	Function Description of Digital Output (DO)	Trigger Method	Control Mode
BRKR	Digital output for the brake control signal which can be adjusted via parameters P1-42 and P1-43.	Level triggered	ALL

7

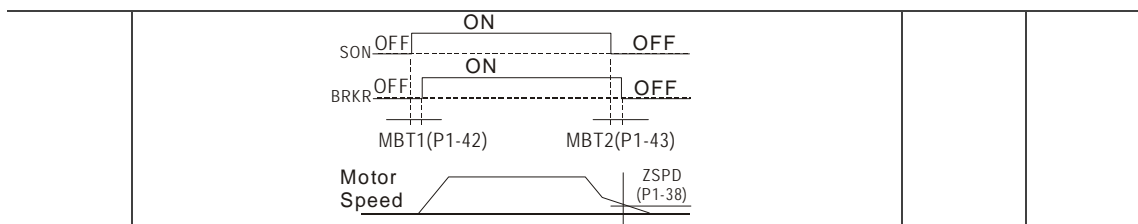

Setting Value: 0x09			
DO Name	Function Description of Digital Output (DO)	Trigger Method	Control Mode
HOME	When homing is completed, it means the position coordinate system and position counter are available and this DO will be ON. When connected to the power, this DO is OFF. After homing is completed, this DO is ON. During the operation, this DO is ON until the counter overflows (including command or feedback) and then the DO becomes OFF. When homing command is triggered, this DO becomes OFF. After homing, this DO becomes ON.	Level triggered	DMCNET

Setting Value: 0x10			
DO Name	Function Description of Digital Output (DO)	Trigger Method	Control Mode
OLW	<p>When the overload setting is reached, this DO is ON.</p> <p><math>t_{OL}</math> = Overload allowable time of the servo x Setting value of P1-56.</p> <p>When the overload accumulative time exceeds <math>t_{OL}</math>, it will output pre-overload warning (OLW). However, if the overload accumulative time exceeds the overload allowable time of the servo, it will output pre-overload error (ALRM).</p> <p>For example: The setting value of pre-overload warning is 60%. (P1-56 = 60) When the output average load of the servo drive is 200%, if the output time exceeds 8 seconds, the servo drive will show the overload alarm (AL006).</p> <p><math>t_{OL}</math> = The output average load of the servo is 200% for 8 seconds x parameter setting value = 8 sec x 60% = 4.8 sec</p> <p>Result: When the output average load of the servo drive is 200% for 4.8 seconds, this DO is ON. (DO code is set to 10) If the time exceeds 8 seconds, then, AL006 occurs and DO.ALRM is ON.</p>	Level triggered	ALL

Setting Value: 0x11			
DO Name	Function Description of Digital Output (DO)	Trigger Method	Control Mode
WARN	Warning output (forward / reverse limit, communication error, under voltage and abnormal fan)	Level triggered	ALL

Setting Value: 0x12			
DO Name	Function Description of Digital Output (DO)	Trigger Method	Control Mode
OVF	Position command overflows (PUU value exceeds the range between -2147483648 and 2147483647)	Level triggered	DMCNET

Setting Value: 0x13			
DO Name	Function Description of Digital Output (DO)	Trigger Method	Control Mode
SNL (SCWL)	Software limit (Reverse limit)	Level triggered	ALL

Setting Value: 0x14			
DO Name	Function Description of Digital Output (DO)	Trigger Method	Control Mode
SPL (SCCWL)	Software limit (Forward limit)	Level triggered	ALL

<b>Setting Value: 0x15</b>			
DO Name	Function Description of Digital Output (DO)	Trigger Method	Control Mode
Cmd_OK	When position command is completed and enter into DMCNET mode, this DO is ON. When position command is executing, this DO is OFF. After the command completes, this DO is ON. When the DO is ON, it means the command is completed, but the motor positioning may not be finished yet. Please refer to DO.TPOS.	Level triggered	DMCNET

<b>Setting Value: 0x17</b>			
DO Name	Function Description of Digital Output (DO)	Trigger Method	Control Mode
MC_OK	When DO.Cmd_OK and TPOS are both ON, this DO is ON. Please refer to P1-48.	Level triggered	DMCNET

<b>Setting Value: 0x19</b>			
DO Name	Function Description of Digital Output (DO)	Trigger Method	Control Mode
SP_OK	In speed mode, when the deviation between the speed feedback and the command is smaller than the setting value of P1-47, then this DO is ON.	Level triggered	Sz

<b>Setting Value: 0x2C</b>			
DO Name	Function Description of Digital Output (DO)	Trigger Method	
Zon1	When the value of the item which is monitored by P0-09 ranges between the setting value of P0-54 and P0-55, then this DO is ON.	ALL	

Note:

When P2-18 ~ P2-22 is set to 0, DO function is invalid.

7

(This page is intentionally left blank.)

7

# Communications

# 8

This chapter provides operation description of MODBUS which is used for setting and accessing general parameters via communication; for motion control network, please refer to the description of DMCNET. Information about character structures of ASCII and RTU mode are also provided in this chapter.

---

8.1	RS-232 Communication Hardware Interface.....	8-2
8.2	RS-232 Communication Parameters Setting.....	8-3
8.3	MODBUS Communication Protocol .....	8-4
8.4	Setting and Accessing Communication Parameters.....	8-15

8

### 8.1 RS-232 Communication Hardware Interface

ASDA-B2-F supports serial communication of RS-232 to access and modify parameters in servo system via communication. Followings are the wiring description.

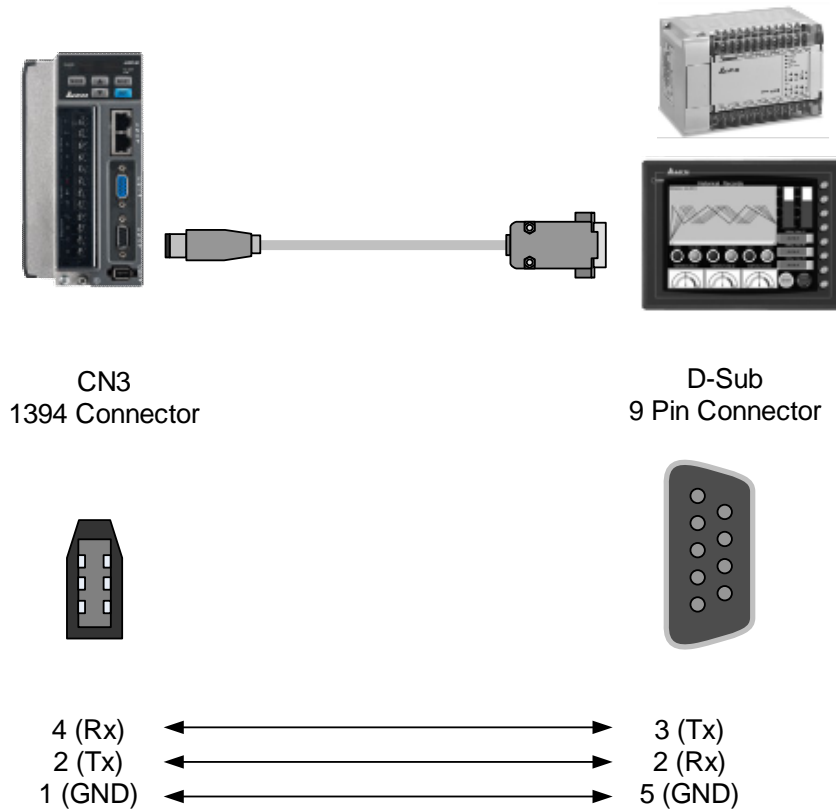

Figure 8-1 Wiring of RS-232

Note:

1. Use a 15-meter communication cable in environment for less interference. If the transmission speed is over 38400 bps, the length of communication cable should be within 3 meters so as to ensure transmission accuracy.
2. Numbers shown in the above figure represent pin number of each connector.

## 8.2 RS-232 Communication Parameters Setting

The following three parameters, P3-00 (Address Setting), P3-01 (Transmission Speed) and P3-02 (Communication Protocol), are essential and must be set for the communication of the servo drive. The rest parameters such as P3-03 (Communication Error Disposal), P3-04 (Communication Timeout Setting), P3-06 (Control Switch of Digital Input), P3-07 (Communication Response Delay Time) and P3-08 (Monitor Mode) are optional.

Related parameters: Please refer to Chapter 7 for detailed description.

Parameter	Abbr.	Function
P3-00	ADR	Address Setting
P3-01	BRT	Transmission Speed
P3-02	PTL	Communication Protocol

8

### 8.3 MODBUS Communication Protocol

There are two modes of MODBUS network communication: ASCII (American Standard Code for Information Interchange) and RTU (Remote Terminal Unit). Users could set the desired communication mode via P3-02. Apart from these two communication modes, this servo drive also supports functions of accessing more than one data (03H), writing one character (06H) and writing multiple characters (10H). Please refer to the following descriptions.

#### Code Description

##### ASCII Mode:

In ASCII mode, data are transmitted in ASCII (American Standard Code for Information Interchange) format. When transmitting data 64H between two stations (Master and Slave), the master will send 36H to represent "6" and 34H to represent "4".

ASCII code for digits 0 to 9 and characters A to F are as follows:

Character	'0'	'1'	'2'	'3'	'4'	'5'	'6'	'7'
ASCII Code	30H	31H	32H	33H	34H	35H	36H	37H
Character	'8'	'9'	'A'	'B'	'C'	'D'	'E'	'F'
ASCII Code	38H	39H	41H	42H	43H	44H	45H	46H

##### RTU Mode:

Every 8-bit data is constituted by two 4-bit characters (hexadecimal). If data 64H is transmitted between two stations, it will be transmitted directly, which is more efficient than ASCII mode.

#### Character Structure

Characters will be encoded into the following framing and transmitted in serial. The checking method of different bit is as the following.

10-bit character frame (for 7-bit character)

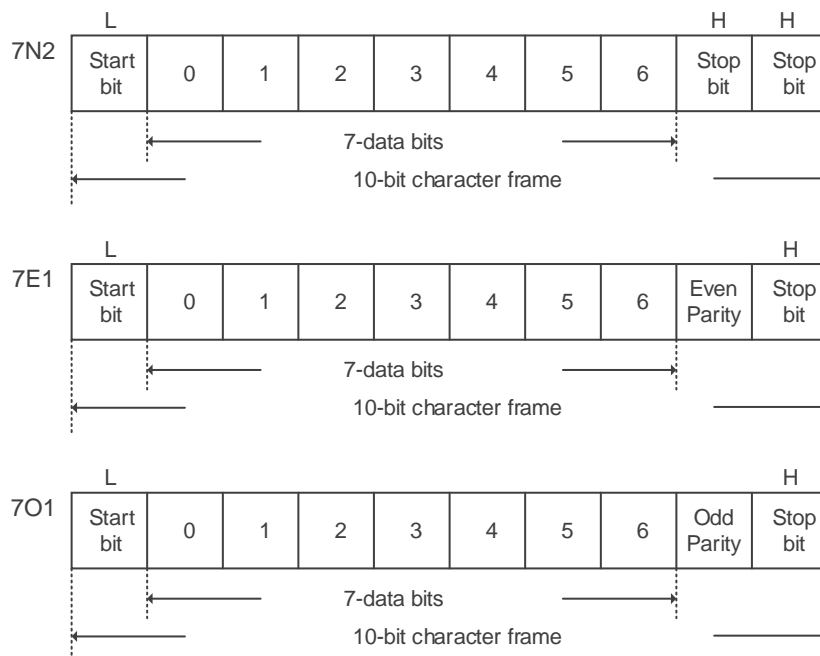

11-bit character frame (for 8-bit character)

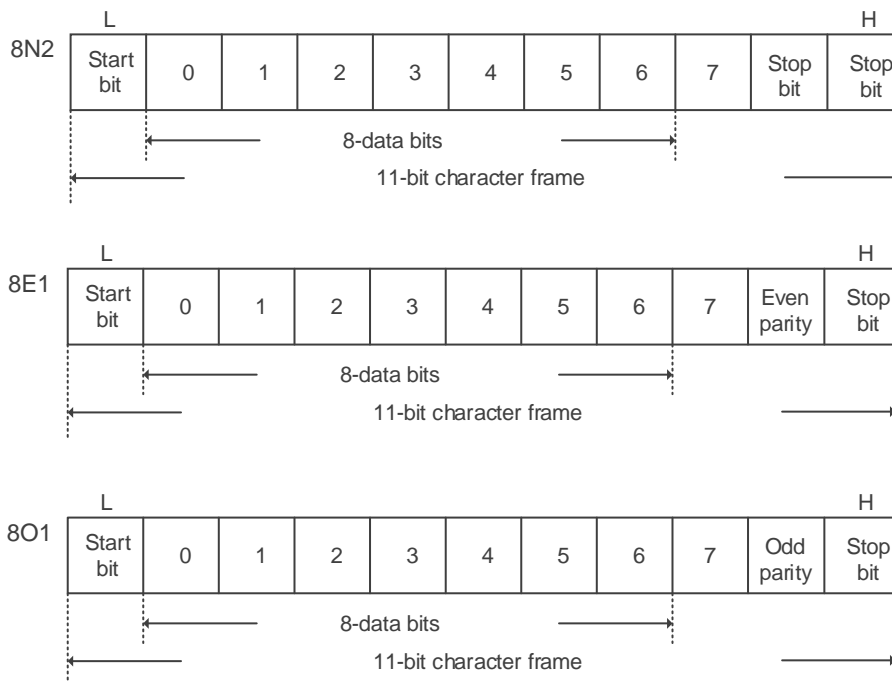

8

**Communication Data Structure**

Definitions of data frame for ASCII and RTU mode are as below:

ASCII Mode:

Start	Start character ":" (3AH)
Slave Address	Communication address: 1 byte consists of 2 ASCII codes
Function	Function code: 1 byte consists of 2 ASCII codes
Data (n-1)	Data content: n word = n x 2 byte = consists of n x 4 ASCII codes, n<=10
.....	
Data (0)	
LRC	Error check: 1 byte consists of 2 ASCII codes
End 1	End code 1: (0DH)(CR)
End 0	End code 0: (0AH)(LF)

The start character of communication in ASCII mode is colon ":" (ASCII code: 3AH). Slave address is constituted by two characters in ASCII code. The end code is CR (Carriage Return) and LF (Line Feed). The communication address, function code, data content and error checking LRC (Longitudinal Redundancy Check), etc. are between the start character and end code.

RTU Mode:

Start	A silent interval of more than 10 ms
Slave Address	Communication address: 1 byte
Function	Function code: 1 byte
Data (n-1)	Data content: n word = n x 2 byte (n<=10)
.....	
Data (0)	
CRC	Error checking: 1 byte
End 1	A silent interval of more than 10 ms

The start and the end of the communication in RTU (Remote Terminal Unit) mode are silent intervals. The communication address, function code, data content and error checking CRC (Cyclical Redundancy Check), etc. are between the start and the end.

Example 1: function code 03H, accessing multiple words:

The master issues command to the 1<sup>st</sup> slave and reads continuous 2 words starting from the start data address 0200H. In response message from the slave, the content of start data address 0200H is 00B1H, and the content of the 2<sup>nd</sup> data address is 1F40H. The maximum allowable data in one single access is 10. The calculation of LRC and CRC will be described in the following section.

ASCII Mode:

Command Message (Master):

Start	':'
Slave Address	'0'
	'1'
Function	'0'
	'3'
Start Data Address	'0'
	'2'
	'0'
	'0'
Data Number (in word)	'0'
	'0'
	'2'
	'2'
LRC Check	'F'
	'8'
End 1	(0DH)(CR)
End 0	(0AH)(LF)

Response Message (Slave):

Start	':'
Slave Address	'0'
	'1'
Function	'0'
	'3'
Data Number (in byte)	'0'
	'4'
Content of Start Data Address 0200H	'0'
	'0'
	'B'
Content of Second Data Address 0201H	'1'
	'1'
	'F'
LRC Check	'4'
	'0'
	'E'
End 1	'8'
	(0DH)(CR)
End 0	(0AH)(LF)

RTU Mode:

Command Message (Master):

Slave Address	01H
Function	03H
Start Data Address	02H (High)
	00H (Low)
Data Number (in word)	00H
	02H
CRC Check Low	C5H (Low)
CRC Check High	B3H (High)

Response Message (Slave):

Slave Address	01H
Function	03H
Data Number (in byte)	04H
Content of Start Data Address 0200H	00H (High)
	B1H (Low)
Content of Second Data Address 0201H	1FH (High)
	40H (Low)
CRC Check Low	A3H (Low)
CRC Check High	D4H (High)

Note:

Before and after transmission in RTU mode, 10 ms of silent interval is needed.

Example 2: function code 06H, writing single word:

The master issues command to the 1<sup>st</sup> slave and writes data 0064H to address 0200H. The slave sends response message to the master after writing is completed. The calculation of LRC and CRC will be described in the following section.

ASCII Mode:

Command Message (Master):

Start	':'
Slave Address	'0'
	'1'
Function	'0'
	'6'
Start Data Address	'0'
	'2'
	'0'
	'0'
Data Content	'0'
	'0'
	'6'
	'4'
LRC Check	'9'
	'3'
End 1	(0DH)(CR)
End 0	(0AH)(LF)

Response Message (Slave):

Start	':'
Slave Address	'0'
	'1'
Function	'0'
	'6'
Start Data Address	'0'
	'2'
	'0'
	'0'
Data Content	'0'
	'0'
	'6'
	'4'
LRC Check	'9'
	'3'
End 1	(0DH)(CR)
End 0	(0AH)(LF)

8

RTU Mode:

Command Message (Master):

Address	01H
Slave Function	06H
Start Data Address	02H (High)
	00H (Low)
Data Content	00H (High)
	64H (Low)
CRC Check Low	89H (Low)
CRC Check High	99H (High)

Response Message (Slave):

Address	01H
Slave Function	06H
Start Data Address	02H (High)
	00H (Low)
Data Content	00H (High)
	64H (Low)
CRC Check Low	89H (Low)
CRC Check High	99H (High)

Note:

Before and after transmission in RTU mode, 10 ms of silent interval is needed.

Example 3: function code 10H, writing multiple words:

The master issues command to the 1<sup>st</sup> slave and writes 0BB8H and 0000H to the start data address 0112H. That is to say, 0BB8H is written into 0112H and 0000H is written into 0113H. The maximum allowable data in one single access is 10. The slave sends the response message to the master after the writing is completed. The calculation of LRC and CRC will be described in the following section.

ASCII Mode:

Command Message (Master):

Start	'.'
Slave Address	'0'
	'1'
Function	'1'
	'0'
Start Data Address	'0'
	'1'
	'1'
	'2'
Data Number (in word)	'0'
	'0'
	'0'
	'2'
Data Number (in byte)	'0'
	'4'
Content of the 1 <sup>st</sup> Data	'0'
	'B'
	'B'
Content of the 2 <sup>nd</sup> Data	'8'
	'0'
	'0'
	'0'
LRC Check	'1'
	'3'
End 1	(0DH)(CR)
End 0	(0AH)(LF)

Response Message (Slave):

Start	'.'
Slave Address	'0'
	'1'
Function	'1'
	'0'
Start Data Address	'0'
	'1'
	'1'
	'2'
Data Number	'0'
	'0'
	'0'
	'2'
LRC Check	'D'
	'A'
End 1	(0DH)(CR)
End 0	(0AH)(LF)

8

RTU Mode:

Command Message (Master):

Slave Address	01H
Function	10H
Start Data Address	01H (High)
	12H (Low)
Data Number (in word)	00H (High)
	02H (Low)
Data Number (in byte)	04H
Content of the 1 <sup>st</sup> Data	0BH (High)
	B8H (Low)
Content of the 2 <sup>nd</sup> Data	00H (High)
	00H (Low)
CRC Check Low	FCH (Low)
CRC Check High	EBH (High)

Response Message (Slave):

Slave Address	01H
Function	10H
Start Data Address	01H (High)
	12H (Low)
Data Number (in word)	00H (High)
	02H (Low)
CRC Check Low	E0H (Low)
CRC Check High	31H (High)

Note:

Before and after transmission in RTU mode, 10 ms of silent interval is needed.

## LRC and CRC Transmission Error Check

The error check of ASCII mode is LRC (Longitudinal Redundancy Check) and CRC (Cyclical Redundancy Check) is for RTU mode.

LRC (ASCII Mode):

Start	':'
Slave Address	'7'
	'F'
Function	'0'
	'3'
Start Data Address	'0'
	'5'
	'C'
	'4'
Data Number	'0'
	'0'
	'0'
	'1'
LRC Check	'B'
	'4'
End 1	(0DH)(CR)
End 0	(0AH)(LF)

The calculation of LRC is to add up all the byte, round down the carry and take 2's complement. For example: 7FH + 03H + 05H + C4H + 00H + 01H = 14CH, round down carry 1 and take 4CH. 2's complement of 4CH is B4H.



CRC (RTU Mode):

The calculation description of CRC value is as the followings:

1. Load a 16-bit register of FFFFH, which is called "CRC" register.
2. (The low byte of CRC register) XOR (The first byte of command), and save the result to CRC register.
3. Check the least significant bit (LSB) of CRC register. If the bit is 0, right move one bit; If the bit is 1, then right move one bit and (CRC register) XOR (A001H).
4. Return to step 3 until step 3 has been executed for 8 times. Go to step 5.
5. Repeat the procedure from step 2 to step 4 until all byte is processed.

The content of CRC register is the CRC value.

After calculating the CRC value, fill in the low word of CRC value in command message, and then the high word. For example, if the result of CRC calculation is 3794H, 94H should be filled in low word and 37H in high word which is shown as below:

ARD	01H
CMD	03H
Start Data Address	01H (High)
	01H (Low)
Data Number (in word)	00H (High)
	02H (Low)
CRC Check Low	94H (Low)
CRC Check High	37H (High)

**Example of CRC Program:**

Calculate CRC value in C language. This function needs two parameters:

unsigned char\* data;

unsigned char length

The function returns the CRC value as a type of unsigned integer.

```
unsigned int crc_chk(unsigned char* data, unsigned char length) {
```

```
    int j;
    unsigned int reg_crc=0xFFFF;

    while( length-- ) {
        reg_crc ^= *data++;
        for (j=0; j<8; j++) {
            if( reg_crc & 0x01 ) { /*LSB(bit 0) = 1 */
                reg_crc = (reg_crc >> 1)^0xA001;
            } else {
                reg_crc = (reg_crc>>1);
            }
        }
    }
    return reg_crc;
}
```

**Example of PC communication program:**

```
#include<stdio.h>
#include<dos.h>
#include<conio.h>
#include<process.h>
#define PORT 0x03F8 /* the address of COM 1 */
#define THR 0x0000
#define RDR 0x0000
#define BRDL 0x0000
#define IER 0x0001
#define BRDH 0x0001
#define LCR 0x0003
#define MCR 0x0004
#define LSR 0x0005
#define MSR 0x0006
unsigned char rdat[60];
/* read 2 data from address 0200H of ASD with address 1 */
unsigned char tdat[60]={':', '0', '1', '0', '3', '0', '2', '0', '0', '0', '0', '2', 'F', '8', '\r', '\n'};
void main() {
    int l;
    outportb(PORT+MCR,0x08); /* interrupt enable */
    outportb(PORT+IER,0x01); /* interrupt as data in */
    outportb(PORT+LCR,( inportb(PORT+LCR) | 0x80 ) );
    /* the BRDL/BRDH can be access as LCR.b7 == 1 */
    outportb(PORT+BRDL,12);
    outportb(PORT+BRDH,0x00);
    outportb(PORT+LCR,0x06); /* set prorocol
                               <7,E,1> = 1AH, <7,O,1> = 0AH
                               <8,N,2> = 07H <8,E,1> = 1BH
                               <8,O,1> = 0BH */

    for( l = 0; l<=16; l++) {
        while( !(inportb(PORT+LSR) & 0x20) ); /* wait until THR empty */
        outportb(PORT+THR,tdat[l]); /* send data to THR */
    }
    l = 0;
    while( !kbhit() ) {
        if( inportb(PORT+LSR)&0x01 ) { /* b0==1, read data ready */
            rdat[l++] = inportb(PORT+RDR); /* read data from RDR */
        }
    }
}
```

}

}

8

## 8.4 Setting and Accessing Communication Parameters

For parameter details, please refer to Chapter 7. Descriptions of parameters which can be written or read via communication are as follows.

Parameters are divided into 6 groups:

- Group 0: Monitor Parameters
- Group 1: Basic Parameters
- Group 2: Extension Parameters
- Group 3: Communication Parameters
- Group 4: Diagnosis Parameters
- Group 5: Motion Setting

### Setting parameters via communication:

Parameters which can be written via communication include:

- Group 0, except (P0-00), (P0-08~P0-13), (P0-44, P0-46) and (P5-50~P0-52)
- Group 1 (P1-00~P1-76)
- Group 2 (P2-00~P2-71)
- Group 3 (P3-00~P3-12)
- Group 4, except (P4-01~P4-04) and (P4-08~P4-09)
- Group 5, except (P5-00)

### Please note that:

- (P3-01) While changing to a new communication speed, the next data will be written in the new transmission speed after the new value is set.
- (P3-02) While changing to a new communication protocol, the next data will be written with the new communication protocol after the new value is set.
- (P4-05) JOG control parameters. For writing method, please refer to chapter regarding parameters and its function.
- (P4-06) Forced DO control (Digital Output Register (Readable and Writable)). This parameter is for DO (Digit Output) testing. Users can write in 1, 2, 4, 8, and 16 to test DO1, DO2, DO3, DO4 and DO5 respectively. Please write 0 after the test so as to inform the servo drive that the test has been completed.
- (P4-10) Adjustment selection. Set P2-08 to 20 (= 14H, in hexadecimal format) first to enable the function, and then write the value of P4-10.
- (P4-11~P4-21) This parameter is for offset adjustment. Do not change the setting unless it is necessary. If it is necessary, please write 22 (= 16H, in hexadecimal format) in parameter P2-08 first to enable the function so as to write the value of P4-11 ~ P4-21.

### Accessing parameters via communication:

Parameters which can be read via communication include:

- Group 0 (P0-00~P0-55)
- Group 1 (P1-00~P1-76)
- Group 2 (P2-00~P2-71)
- Group 3 (P3-00~P3-12)
- Group 4 (P4-00~P4-24)
- Group 5 (P5-00~P5-35)

(This page is intentionally left blank.)

8

# Troubleshooting

# 9

This chapter provides alarm descriptions and corrective actions which users can refer to for troubleshooting.

---

9.1 Alarm of Servo Drive .....	9-2
9.2 Alarm of DMCNET Communication .....	9-3
9.3 Alarm of Motion Control .....	9-4
9.4 Causes and Corrective Actions .....	9-5

9

### 9.1 Alarm of Servo Drive

Display	Alarm Name	Alarm Description	Corresponding DO	Servo Status
AL001	Over current	The current of the main circuit is 1.5 times higher than the instantaneous current of the motor.	ALM	OFF
AL002	Over voltage	The voltage of the main circuit is higher than the standard voltage.	ALM	OFF
AL003	Under voltage	The voltage of the main circuit is lower than the standard voltage.	WARN	OFF
AL004	Motor combination error	The drive corresponds to the wrong motor.	ALM	OFF
AL005	Regeneration error	Regeneration error.	ALM	OFF
AL006	Overload	The motor and the drive is overload.	ALM	OFF
AL007	Over speed	Motor speed exceeds the normal speed range.	ALM	OFF
AL009	Excessive deviation of position command	The deviation of position command exceeds the allowable setting value.	ALM	OFF
AL011	Encoder error	The encoder produces abnormal pulse.	ALM	OFF
AL012	Adjustment error	While executing electrical adjustment, the adjusted value exceeds the allowable value.	ALM	OFF
AL013	Emergency Stop	The emergency stop button is pressed.	WARN	OFF
AL014	Reverse limit error	Activate the reverse limit switch.	WARN	OFF
AL015	Forward limit error	Activate the forward limit switch.	WARN	ON
AL016	IGBT overheat	The temperature of IGBT is too high.	ALM	OFF
AL017	Abnormal EEPROM	It is in error when DSP accesses EEPROM.	ALM	OFF
AL018	Abnormal signal output	The encoder output exceeds the rated output frequency.	ALM	OFF
AL019	Serial communication error	RS-232 communication is in error.	ALM	OFF
AL020	Serial communication timeout	RS-232 communication timeout.	WARN	ON
AL022	Main circuit power lack phase	The RST power cable of main circuit power is loose or no power has been applied.	WARN	OFF
AL023	Early warning for overload	Early warning for overload.	WARN	ON
AL024	Encoder initial magnetic field error	The magnetic field of the encoder U, V, W signal is in error.	ALM	OFF
AL025	The internal of the encoder is in error	The internal memory of the encoder and the internal counter are in error.	ALM	OFF
AL026	Unreliable internal data of the encoder	The error of the internal data has been detected for three times continuously.	ALM	OFF
AL027	The internal of the motor is in error	The internal reset of the encoder is in error.	ALM	OFF
AL028	Encoder voltage error or the internal of the encoder is in error	Charging circuit of the servo drive is not removed and the battery voltage is higher than the specification (>3.8 V) or the encoder signal is in error.	ALM	OFF
AL029	Gray code error	Absolute position is in error.	ALM	OFF
AL030	Motor crash error	When the motor crashes the equipment, it reaches the torque of P1-57 and exceeds the time set by P1-58.	ALM	OFF
AL031	Incorrect wiring of motor power cable	Incorrect wiring of motor power cable (U, V, W, GND).	ALM	OFF
AL034	Internal communication of the encoder is in error	1. Internal communication error in absolute encoder. 2. Internal error of other types of encoder.	ALM	OFF
AL035	Encoder temperature exceeds the protective	Encoder temperature exceeds the protective range.	ALM	OFF

Display	Alarm Name	Alarm Description	Corresponding DO	Servo Status
	range			
<b>AL044</b>	Warning of servo drive function overload	Warning of servo drive function overload.	WARN	OFF
<b>AL060</b>	The absolute position is lost	Due to battery under voltage or failure of power supply, the absolute encoder loses the internal record.	WARN	OFF
<b>AL061</b>	Encoder under voltage	The battery voltage of absolute encoder is lower than the specification.	WARN	ON
<b>AL062</b>	The multi-turn count of absolute encoder overflows	The multi-turn count of absolute encoder exceeds the maximum range: -32768 ~ +32767.	WARN	ON
<b>AL067</b>	Encoder temperature warning	Encoder temperature exceeds the warning level. (But it is still within the protective range.)	WARN	N/A
<b>AL069</b>	Wrong motor type	Incremental motor is not allowed to activate absolute functions.	ALM	OFF
<b>AL070</b>	Encoder does not complete the command which is issued by the servo drive	Servo drive has not completely writing barcode into encoder or the encoder does not complete the command issued by the servo drive.	WARN	OFF
<b>AL099</b>	DSP firmware upgrade	EEPROM has not been reset after upgrading the firmware. The fault can be cleared when firstly set P2-08 to 30. Then set P2-08 to 28. And re-power on the drive.	ALM	OFF

## 9.2 Alarm of DMCNET Communication

Display	Alarm Name	Alarm Description	Corresponding DO	Servo Status
<b>AL111</b>	DMCNET SDO overflow	Rx Buffer overflows. (receive more than two DMCNET SDOs in 1 millisecond)	ALM	ON
<b>AL185</b>	Abnormal DMCNET Bus hardware	The communication of DMCNET Bus is breakdown.	ALM	ON

9

### 9.3 Alarm of Motion Control

Display	Alarm Name	Alarm Description	Corrective Actions	Corresponding DO	Servo Status
AL201	An error occurs when loading DMCNET data	An error occurs when loading data from EEPROM.	Re-power on	WARN	ON
AL235	PR command overflows	Feedback position counter overflows and executes the absolute positioning command.	Controller issues alarm reset command.	WARN	ON
AL245	PR positioning is over time	The execution of positioning command exceeds the time limit.	Same as above	WARN	ON
AL283	Forward software limit	The value of position command is bigger than forward software limit.	The fault will be cleared automatically when the motor operates backwards.	WARN	ON
AL285	Reverse software limit	The value of position command is smaller than reverse software limit.	The fault will be cleared automatically when the motor operates backwards.	WARN	ON
AL289	Feedback position counter overflows	Feedback position counter overflows.	Controller issues alarm reset command.	WARN	ON
AL301	DMCNET fails to synchronize	DMCNET mode fails to synchronize with the controller.	Same as above	WARN	ON
AL302	The synchronized signal of DMCNET is sent too fast	The synchronized signal of DMCNET is sent too fast.	Same as above	WARN	ON
AL303	The synchronized signal of DMCNET is sent too slow	The synchronized signal of DMCNET has not been received in time.	Same as above	WARN	ON
AL304	DMCNET IP command fails	Command cannot be sent in DMCNET mode.	Same as above	WARN	ON
AL555	System failure	DSP processing error.	N/A	N/A	No switching

Note:

If an alarm occurs and is different from the alarm showed in Alarm of Servo Drive, **Alarm of DMCNET Communication** and **Alarm of Motion Control**, please contact local distributors or technical personnel.

## 9.4 Causes and Corrective Actions

AL001 Over current		Cleared by DI.ARST
Causes	Checking Method	Corrective Actions
The drive output is short-circuited.	Check if the wiring between the motor and the drive is correct and see if the wire is short-circuited.	Eliminate short-circuit and avoid metal conductor being exposed.
The motor wiring is in error.	Check if the wiring steps are correct when connecting the motor to the drive.	Rewiring by following the wiring description from the user manual.
IGBT is abnormal.	The temperature of the heat sink is abnormal.	Send the drive back to the distributors or contact Delta.
The setting of control parameter is in error.	Check if the setting value exceeds the default setting.	Setting back to the default setting and then gradually adjust the value.
The setting of control command is in error.	Check if the command is doing reasonable variation.	Modify the switching rate of issuing command or enable filter.

AL002 Over voltage		Cleared by DI.ARST
Causes	Checking Method	Corrective Actions
The input voltage of the main circuit is higher than the rated allowable voltage.	Use voltmeter to see if the input voltage of the main circuit is within the rated allowable voltage value. (please refer to Appendix A)	Connect to the correct power supply or serial voltage regulator.
Wrong power input (incorrect power system)	Use voltmeter to see if the power system matches with the specification.	Connect to the correct power supply or serial voltage transformer.
The hardware of the servo drive is damaged.	Use voltmeter to see if the input voltage of the main circuit is within the rated allowable voltage value but the error still occurs.	Send the drive back to the distributors or contact with Delta.

AL003 Under voltage		Cleared when voltage returns to normal value
Causes	Checking Method	Corrective Actions
The input voltage of the main circuit is lower than the rated allowable voltage.	Check if the input voltage wiring of the main circuit is normal.	Re-confirm the voltage wiring.
No power supply for the main circuit	Use the voltmeter to see if the voltage of the main circuit is normal.	Check the power switch.
Wrong power input (incorrect power system)	Use the voltmeter to see if the power system matches the specification.	Connect to the correct power supply or serial voltage transformer.

AL004 Motor combination error		Cleared after re-power on
Causes	Checking Method	Corrective Actions
The encoder is damaged.	The encoder is abnormal.	Change the motor.
The encoder is loose.	Check the encoder connector.	Install the motor again.
Motor combination error	Connect to the right motor.	Change the motor.

9

AL005		Regeneration error	Cleared by DI.ARST
Causes	Checking Method	Corrective Actions	
The value of regenerative resistor is too low or the external regenerative resistor is unconnected.	Check the connection of regenerative resistor.	Calculate the value for regenerative resistor again and reset the value of P1-52 and P1-53 again. If the alarm has not been cleared, please send the drive back to Delta.	
Parameter P1-53 is not set to zero when the regenerative resistor is not in use.	Check if parameter P1-53 of regenerative resistor is set to zero.	Set parameter P1-53 of regenerative resistor to zero when it is not applying.	
Parameter P1-52 and P1-53 are not correctly set.	Check the setting value of parameter P1-52 and P1-53.	Correctly reset the value of P1-52 and P1-53 again.	

AL006		Overload	Cleared by DI.ARST
Causes	Checking Method	Corrective Actions	
Over the rated load of the drive and continuously excessive using.	Set parameter P0-02 to 11 and see if the average torque [%] is over 100% all the time.	Increase the motor capacity or reduce the load.	
The setting of the control system parameter is inappropriate.	1. Check if there is any mechanical vibration. 2. Check if the acceleration/deceleration constant is set too fast.	1. Adjust the gain value of the control circuit. 2. Slow down the acceleration/deceleration setting time.	
Wrong wiring of the motor and the encoder.	Check the wiring of U, V, W and the encoder.	Correct wiring	
The encoder of the motor is defective.	Send the drive back to the distributors or contact Delta.		

AL007		Over speed	Cleared by DI.ARST
Causes	Checking Method	Corrective Actions	
Inappropriate setting of parameter P2-34	Check if the setting value of P2-34 is too small. (Condition for over speed warning)	Correctly set the setting value of P2-34. (Condition for over speed warning)	

AL009		Excessive deviation of position command	Cleared by DI.ARST
Causes	Checking Method	Corrective Actions	
Parameter P2-35 is set too small.	Check the setting value of parameter P2-35. (Warning condition of excessive position deviation)	Increase the setting value of P2-35. (Warning condition of excessive position deviation)	
The setting of the gain value is too small.	Check if the setting value is appropriate.	Correctly adjust the gain value.	
The torque limit is too low.	Check the torque limit value.	Correctly adjust the torque limit value.	
Excessive external load.	Check the external load.	Reduce the external load or evaluate the motor capacity again.	
Improper setting of E-Gear ratio.	Make sure the proportion of P1-44 and P1-45 is appropriate.	Correctly set up E-Gear ratio.	

<b>AL011 Encoder error</b>		Cleared after re-power on
Causes	Checking Method	Corrective Actions
Wrong wiring of the encoder	Check if the wiring follows the suggested wiring in the user manual.	Correct wiring
The encoder is loose.	Check the CN2 connector of the drive and the encoder connector.	Install the encoder again.
Bad connection of the encoder	Check if the connection between CN2 connector of the drive and the encoder of the servo motor is loose.	Reconnect the wiring.
The encoder is damaged.	Check if the motor is damaged.	Change the motor.

<b>AL012 Adjustment error</b>		N/A
Causes	Checking Method	Corrective Actions
Abnormal current adjustment	Reset power supply.	If the error still occurs after reset, send the drive back to the distributors or contact with Delta.

<b>AL013 Emergency stop</b>		Automatically cleared after DI.EMGS is OFF
Causes	Checking Method	Corrective Actions
The emergency stop button is pressed.	Check if the emergency stop button is enabled.	Release emergency stop button.

<b>AL014 Reverse limit error</b>		Cleared by DI.ARST, Servo Off or after motor operates backwards
Causes	Checking Method	Corrective Actions
Reverse limit switch is activated.	Check if the reverse limit switch is activated.	Release the reverse limit switch.(e.g. motor operates backwards)

<b>AL015 Forward limit error</b>		Cleared by DI.ARST, Servo Off or after motor operates backwards
Causes	Checking Method	Corrective Actions
Forward limit switch is activated.	Check if the forward limit switch is activated.	Release the forward limit switch.(e.g. motor operates backwards)

<b>AL016 IGBT overheat</b>		Cleared by DI.ARST
Causes	Checking Method	Corrective Actions
Over the rated loading of the drive and continuously excessive using	Check if the drive is overloading or the motor current is too high.	Increase the motor capacity or reduce the load.
The drive output is short-circuited.	Check the drive output wiring.	Correct wiring.

9

<b>AL017</b>	<b>Abnormal EEPROM</b>	If the alarm occurs as soon as servo on, please reset the parameters and re-power on. If the alarm occurs during the operation, clear the alarm by DI.ARST
--------------	------------------------	--

Causes	Checking Method	Corrective Actions
Error occurs when writing parameters into EEPROM.	Press the SHIFT key on the panel and it shows EXGAB.  X = 1, 2, 3 G = group code of the parameter AB = parameter number (hexadecimal format) If it shows E320A, it means it is parameter P2-10; if it shows E3610, it means it is parameter P6-16, please check the displayed parameter.	If the fault occurs when the servo drive connects to power, it means one of the parameters exceed the reasonable range. Re-power on after adjusting.  The fault occurs in normal operation which means an error occurs while writing the parameter. The alarm can be cleared by DI.ARST.
Abnormal hidden parameter	Press the SHIFT key on the panel and it shows E100X.	The fault occurs in parameter reset. The setting of the drive is wrong. Please set the correct type of the drive.
Data in ROM is damaged.	Press the SHIFT key on the panel and it shows E0001.	The fault occurs when it is servo-on. Usually it is because the data in ROM is damaged or there is no data in ROM. Please send the drive back to the distributors or contact with Delta.

<b>AL018</b>	<b>Abnormal signal output</b>	Cleared by DI.ARST
--------------	-------------------------------	--------------------

Causes	Checking Method	Corrective Actions
The encoder is in error and cause abnormal signal output.	Check the fault records (P4-00~P4-05). See if the alarm exists with encoder error (AL011, AL024, AL025, AL026).	Conduct the corrective actions of AL011, AL024, AL025 or AL026.
The output pulse exceeds the hardware allowable range.	Check if the following conditions happen: P1-76 < Motor Speed or  $\frac{\text{Motor Speed}}{60} \times P1-46 \times 4 > 19.8 \times 10^6$	Correctly set parameter P1-76 and P1-46: P1-76 > Motor Speed and  $\frac{\text{Motor Speed}}{60} \times P1-46 \times 4 < 19.8 \times 10^6$

<b>AL019</b>	<b>Serial communication error</b>	Cleared by DI.ARST
--------------	-----------------------------------	--------------------

Causes	Checking Method	Corrective Actions
Improper setting of communication parameter	Check the setting value of communication parameter.	Correctly set the parameter value.
Incorrect communication address	Check the communication address.	Correctly set the communication address.
Incorrect communication value	Check the accessing value.	Correctly set the value.

<b>AL020</b>	<b>Serial communication timeout</b>	Cleared by DI.ARST
--------------	-------------------------------------	--------------------

Causes	Checking Method	Corrective Actions
Improper setting of the timeout parameter	Check the parameter setting.	Correctly set the value.
The drive has not received the communication command for a long time.	Check if the communication cable is loose or broken.	Correct wiring

<b>AL022</b>		<b>Main circuit power lack phase</b>	Cleared by DI.ARST
Causes	Checking Method	Corrective Actions	
The main circuit power is abnormal.	Check if RST power cable is loose or no power is applied. This alarm occurs when drive of 1.5 kW (or below) is not connected to three-phase power supply; for drive of 2 kW (or above), the alarm occurs when one single phase is not connected to the power supply.	Correctly connect to the power. If the alarm still exists, please send the drive back to the distributors or contact with Delta.	
<b>AL023</b>		<b>Early warning for overload</b>	Cleared by DI.ARST
Causes	Checking Method	Corrective Actions	
Early warning for overload	<ol style="list-style-type: none"> <li>1. Check if the drive is used in overload condition.</li> <li>2. Check if the value of parameter P1-56 is set to be too small.</li> </ol>	<ol style="list-style-type: none"> <li>1. Please refer to the corrective actions of AL006.</li> <li>2. Please increase the setting value of P1-56. Or set the value to over 100 to deactivate the function of early warning for overload.</li> </ol>	
<b>AL024</b>		<b>Encoder initial magnetic field error</b>	Cleared after re-power on
Causes	Checking Method	Corrective Actions	
Encoder initial magnetic field error (The magnetic field of the encoder U, V, W signal is in error.)	<ol style="list-style-type: none"> <li>1. Check if the servo motor is properly grounded.</li> <li>2. Check if the encoder cable is separated from the power supply or high-current cable to avoid interference.</li> <li>3. Check if the shielding cables are used in the wiring of the encoder.</li> </ol>	If issue persists, please send the drive back to the distributors or contact with Delta.	
<b>AL025</b>		<b>The internal of the encoder is in error</b>	Cleared after re-power on
Causes	Checking Method	Corrective Actions	
The internal of the encoder is in error. (The internal memory and the internal counter are in error)	<ol style="list-style-type: none"> <li>1. Check if the servo motor is properly grounded.</li> <li>2. Check if the encoder cable is separated from the power supply or high-current cable to avoid interference.</li> <li>3. Check if the shielding cables are used in the wiring of the encoder.</li> </ol>	<ol style="list-style-type: none"> <li>1. Please connect the UVW connector (color green) to the heat sink of the servo drive.</li> <li>2. Please check if the encoder cable is separated from power supply or the high-current cable.</li> <li>3. Please use cables with shielding mesh.</li> <li>4. If issue persists, please send the drive back to the distributors or contact with Delta.</li> </ol>	
When power on, the motor operates because of mechanical inertia or other causes.	When power on, please make sure the motor shaft stands still and will not operate.	When power on, please make sure the motor shaft stands still and will not operate.	

9

AL026 Unreliable internal data of the encoder		Cleared after re-power on
Causes	Checking Method	Corrective Actions
The encoder is in error. (Errors occur in the internal data for three times continuously)	<ol style="list-style-type: none"> <li>1. Check if the servo motor is properly grounded.</li> <li>2. Check if the encoder cable is separated from the power supply or high-current cable to avoid interference.</li> <li>3. Check if the shielding cables are used in the wiring of the encoder.</li> </ol>	<ol style="list-style-type: none"> <li>1. Please connect the UVW connector (color green) to the heat sink of the servo drive.</li> <li>2. Please check if the encoder cable is separated from the power supply or the high-current cable.</li> <li>3. Please use cables with shielding mesh.</li> <li>4. If issue persists, please send the drive back to the distributors or contact with Delta.</li> </ol>

AL027 The internal of the motor is in error		Cleared after re-power on
Causes	Checking Method	Corrective Actions
The internal reset of the encoder is in error.	<ol style="list-style-type: none"> <li>1. Check if the encoder communication cable is properly connected.</li> <li>2. Check if the power supply is stable.</li> <li>3. Check if the operation temperature exceeds 95° C.</li> </ol>	<ol style="list-style-type: none"> <li>1. Check if the encoder communication cable is normal.</li> <li>2. Please use encoder communication cable with shielding mesh.</li> <li>3. If issue persists, please send the drive back to the distributors or contact with Delta.</li> </ol>

AL028 Encoder voltage error or the internal of the encoder is in error		Cleared after re-power on
Causes	Checking Method	Corrective Actions
Battery voltage is too high.	<ol style="list-style-type: none"> <li>1. Check if there is charging circuit in the servo drive.</li> <li>2. Check if the battery is correctly installed. (Voltage &gt; 3.8 V)</li> </ol>	Please do the check according to the procedure of over voltage. When corrective actions are done, AL028 will be cleared automatically.
The internal of the encoder is in error.	<ol style="list-style-type: none"> <li>1. Check if it is absolute encoder.</li> <li>2. Check if the servo motor is properly grounded.</li> <li>3. Check if the encoder cable is separated from the power supply or high-current cable to avoid interference.</li> <li>4. Check if the shielding cables are used in the wiring of the encoder.</li> </ol>	<ol style="list-style-type: none"> <li>1. If the situation is not improving, please send the drive back to the distributors or contact with Delta.</li> <li>2. Please connect the UVW connector (color green) to the heat sink of the servo drive.</li> <li>3. Please check if the encoder cable is separated from power supply or high-current cable.</li> <li>4. Please use shielding mesh. If the situation is not improving, please send the drive back to the distributors or contact with Delta.</li> </ol>

AL029 Gray code error		Cleared after re-power on
Causes	Checking Method	Corrective Actions
Absolute position is in error.	Re-power on to operate the motor and check if the alarm occurs again.	If the alarm occurs again, please change the encoder.

<b>AL030</b>	<b>Motor crash error</b>	Cleared by DI.ARST	
Causes	Checking Method	Corrective Actions	
Motor crash error	<ol style="list-style-type: none"> <li>1. Check if P1-57 is enabled.</li> <li>2. Check if P1-57 is set to be too small and the time set by P1-58 is too short.</li> </ol>	<ol style="list-style-type: none"> <li>1. If the function is enabled by mistake, please set P1-57 to 0.</li> <li>2. Please set the value of P1-57 according to the actual torque. If the value is set to be too small, the alarm will be triggered by mistake. However, if the value is set to be too big, it will lose the protection function.</li> </ol>	

<b>AL031</b>	<b>Incorrect wiring of motor power cable</b>	Cleared after re-power on	
Causes	Checking Method	Corrective Actions	
Incorrect wiring of motor power cable (U, V, W, GND)	Check if motor power cable (U, V, W, GND) is incorrectly connected.	Correctly wire the power cable (U, V, W, GND) according to the user manual and make sure it is grounded.	

<b>AL034</b>	<b>Internal communication of the encoder is in error</b>	Cleared after re-power on	
Causes	Checking Method	Corrective Actions	
Internal communication of the encoder is in error.	<ol style="list-style-type: none"> <li>1. Internal communication error of the absolute encoder.</li> <li>2. Internal error of other types of encoder.</li> </ol>	Correctly rewire the battery and re-power on.	

<b>AL035</b>	<b>Encoder temperature exceeds the protective range</b>	Motor temperature needs to be lower than 100°C; then, the alarm can be cleared after re-power on.	
Causes	Checking Method	Corrective Actions	
Encoder temperature is too high (Above 100°C).	Set P0-02 to 120 (temperature display) and check if the displayed value is the same with the motor temperature.	<ol style="list-style-type: none"> <li>1. Improve heat dissipation or reduce operation load. The temperature should be under 100°C.</li> <li>2. If the displayed temperature of the encoder is higher than the motor's (over 30°C), please send the motor back to distributors.</li> </ol>	

<b>AL044</b>	<b>Warning of servo drive function overload</b>	Se P2-66 Bit4 to 1 and re-power on to clear this alarm	
Causes	Checking Method	Corrective Actions	
Warning of servo drive function overload	N/A	Set P2-66 Bit4 to 1 to clear the alarm.	

9

AL060		The absolute position is lost	Cleared after re-power on
Causes	Checking Method		Corrective Actions
Battery is under voltage.	Check if the voltage of the battery is lower than 2.8 V.		After replacing the battery, conduct homing again. Please refer to the description of absolute coordinate initialization in Chapter 10.
The battery is replaced when the control power is OFF.	Do not replace or remove the battery when the control power is OFF.		Conduct homing again. Please refer to the description of absolute coordinate initialization in Chapter 10.
After activating the absolute function, the absolute coordinate initialization has not been completed.	<ol style="list-style-type: none"> <li>1. Install the battery.</li> <li>2. Check the wiring between battery box and the battery power cable of the servo drive.</li> <li>3. Check the wiring of the encoder.</li> </ol>		Conduct homing again. Please refer to the description of absolute coordinate initialization in Chapter 10.
Bad connection of the battery power circuit.	<ol style="list-style-type: none"> <li>1. Check the wiring of the encoder.</li> <li>2. Check the wiring between battery box and the servo drive.</li> </ol>		Connect or repair the wiring of the battery so as to supply power to the encoder. Conduct homing again. Please refer to the description of absolute coordinate initialization in Chapter 10.

AL061		Encoder under voltage	AL061 will be automatically cleared after new battery is installed
Causes	Checking Method		Corrective Actions
Battery voltage is too low.	<ol style="list-style-type: none"> <li>1. Check from the panel if the battery voltage is lower than 3.1 V. (tentative specification)</li> <li>2. Check if the battery voltage is lower than 3.1 V. (tentative specification )</li> </ol>		Replace the battery when the control power is ON. This alarm will be automatically cleared after new battery is installed.

AL062		The multi-turn count of absolute encoder overflows	Cleared after re-power on
Causes	Checking Method		Corrective Actions
The multi-turn count of absolute encoder exceeds the maximum range: -32768 ~ +32767.	Check if the operation turn is within the range from -32768 to +32767.		Conduct homing again. Please refer to the description of absolute coordinate initialization in Chapter 10.

AL067		Encoder temperature warning	Cleared by DI.ARST
Causes	Checking Method		Corrective Actions
Encoder temperature warning (85 ~ 100 °C)	Set P0-02 to 120 (temperature display) and check if the displayed value is the same with the motor temperature.		<ol style="list-style-type: none"> <li>1. Improve heat dissipation or reduce operation load. The temperature should be under 100 °C.</li> <li>2. If the displayed temperature of the encoder is higher than the motor's (over 30°C), please send the motor back to distributors.</li> </ol>

<b>AL069</b>	<b>Wrong motor type</b>	Set P2-69=0 and re-power on to clear the alarm
--------------	-------------------------	--

Causes	Checking Method	Corrective Actions
Incremental motor is not allowed to activate the absolute function.	1. Check if the motor is with incremental or absolute encoder. 2. Check the setting value of P2-69.	If users desire to use absolute function, please choose absolute motor. If not, please set parameter P2-69 to 0.

<b>AL070</b>	<b>Encoder does not complete the command issued by servo drive</b>	Cleared after re-power on
--------------	--	---------------------------

Causes	Checking Method	Corrective Actions
Servo drive has not completely written barcode into encoder or the encoder does not complete the command issued by servo drive.	Check if the wiring is correct or there is any loose connection.	Correctly conduct wiring.

<b>AL099</b>	<b>DSP firmware upgrade</b>	Set P2-08=30 then 28 and this alarm can be cleared after re-power on
--------------	-----------------------------	--

Causes	Checking Method	Corrective Actions
DSP firmware upgrade	Check if the firmware is upgraded.	Set P2-08 to 30, then 28 and this alarm can be cleared after re-power on.

<b>AL111</b>	<b>DMCNET SDO receives overflow</b>	Check if the controller receives (sends) one DMCNET SDO in 1 ms
--------------	-------------------------------------	---

Causes	Checking Method	Corrective Actions
Rx Buffer overflow (More than two SDOs are received in 1 ms)	Check if the controller receives (sends) more than one DMCNET SDO in 1 ms.	Check if the controller receives (sends) one DMCNET SDO in 1 ms.

<b>AL185</b>	<b>Abnormal DMCNET Bus hardware</b>	Cleared after re-power on
--------------	-------------------------------------	---------------------------

Causes	Checking Method	Corrective Actions
Abnormal DMCNET Bus hardware	1. Check if the communication cable of DMCNET Bus is normal. 2. Check if the communication quality is normal. (It is suggested to use common grounding and shielding cables.)	Re-power on

<b>AL201</b>	<b>An error occurs when loading DMCNET data</b>	Cleared after re-power on
--------------	---	---------------------------

Causes	Checking Method	Corrective Actions
An error occurs when loading DMCNET data.	1. If the alarm is cleared when re-power on, it means the error occurs instantaneously when accessing in the previous time. 2. If the error still exists after re-power on, it means the data in EEPROM is damaged. Enter the correct value again: if users desire to enter default value, they can set P2-08 to 30, then 28.	Re-power on

9

AL235		PR command overflows	Conduct homing to clear this alarm
Causes	Checking Method		Corrective Actions
PR command overflows	<p>Incremental Type: Continuous operation in one direction in PR mode causes position feedback register (FB_PUU) overflows. Thus, the coordinate system cannot reflect the correct position. If issuing the absolute positioning command at this moment, the error will occur.</p> <p>Absolute Type: If issuing the absolute positioning command in the following situations, this error will occur:</p> <ol style="list-style-type: none"> <li>1. Feedback position register (FB_PUU) overflows.</li> <li>2. When P1-01.Z is modified, homing has not been completed yet.</li> <li>3. When electronic gear ratio (P1-44, P1-45) is modified, homing has not been completed yet.</li> <li>4. Function of returning to the original point is triggered and homing has not completed yet.</li> <li>5. AL060 and AL062 occur.</li> </ol>		Conduct homing

AL245		PR positioning is over time	N/A
Causes	Checking Method		Corrective Actions
PR positioning is over time.	N/A		If this alarm occurs, please directly send the servo drive back to Delta without making any modification.

AL283		Forward software limit	Issue alarm reset to clear this alarm
Causes	Checking Method		Corrective Actions
Forward software limit	<p>Forward software limit is determined by position command, not the actual feedback position. That is because the command always arrives first and then the feedback. When the protection function is activated, the actual position might not exceed the limit yet. Therefore, setting an appropriate decelerating time could satisfy the demand. Please refer to the description of P5-03.</p>		Issue alarm reset

AL285		Reverse software limit	Issue alarm reset to clear this alarm
Causes	Checking Method		Corrective Actions
Reverse software limit	<p>Reverse software limit is determined by position command, not the actual feedback position. That is because the command always arrives first and then the feedback. When the protection function is activated, the actual position might not exceed the limit yet. Therefore, setting an appropriate decelerating time could satisfy the demand. Please refer to the description of P5-03.</p>		Issue alarm reset

AL289	Feedback position counter overflows	N/A
Causes	Checking Method	Corrective Actions
Feedback position counter overflows.	N/A	If this alarm occurs, please directly send the servo drive back to Delta without making any modification.

AL301	DMCNET fails to synchronize	Issue alarm reset to clear this alarm
Causes	Checking Method	Corrective Actions
DMCNET fails to synchronize.	<ol style="list-style-type: none"> <li>1. Check if the communication quality of the cable is normal.</li> <li>2. Check if the controller sends SYNC signal successfully.</li> <li>3. Check if the setting of P3-09 is reasonable. (It is better to use the default value)</li> </ol>	Issue alarm reset

AL302	The synchronized signal of DMCNET is sent too fast	Issue alarm reset to clear this alarm
Causes	Checking Method	Corrective Actions
The synchronized signal of DMCNET is sent too fast.	<ol style="list-style-type: none"> <li>1. Check if the setting of P3-09 is reasonable. (It is better to use the default value)</li> <li>2. Check if the order of the controller is correct.</li> </ol>	Issue alarm reset.

AL303	The synchronized signal of DMCNET is sent too slow	Issue alarm reset to clear this alarm
Causes	Checking Method	Corrective Actions
The synchronized signal of DMCNET is sent too slow.	<ol style="list-style-type: none"> <li>1. Check if the communication quality of the cable is normal.</li> <li>2. Check if the setting of P3-09 is reasonable. (It is better to use the default value)</li> <li>3. Check if the order of the controller is correct.</li> </ol>	Issue alarm reset.

AL304	DMCNET IP command fails	Issue alarm reset to clear this alarm
Causes	Checking Method	Corrective Actions
DMCNET IP command fails.	If the calculating time of IP mode is too long, please disable USB monitoring function.	Issue alarm reset.

AL555	System failure	N/A
Causes	Checking Method	Corrective Actions
DSP processing error	N/A	If this alarm occurs, please directly send the servo drive back to Delta without making any modification.

(This page is intentionally left blank.)

9

# Absolute System

# 10

This chapter introduces the application of absolute servo system, including the wiring and installation of absolute type encoder, setting steps and operation procedures when initializing absolute position for the first time. In addition, alarm information related to absolute system can also be found in this chapter.

10.1	Absolute Type of Battery Box and Wiring Rods.....	10-3
10.1.1	Specifications.....	10-3
10.1.2	Battery Box Dimensions .....	10-5
10.1.3	Connection Cable for Absolute Encoder.....	10-6
10.1.4	Battery Box Cable.....	10-8
10.2	Installation.....	10-9
10.2.1	Install Battery Box in Servo System .....	10-9
10.2.2	How to Install the Battery.....	10-13
10.2.3	How to Replace a Battery .....	10-14
10.3	Parameters Related to Absolute Servo System.....	10-16
10.4	Servo Drive Alarm List for Absolute Function and Monitoring Variables .....	10-17
10.5	System Initialization and Operation Procedures.....	10-18
10.5.1	System Initialization.....	10-18
10.5.2	Pulse Number .....	10-19
10.5.3	PUU Number .....	10-20
10.5.4	To Initialize the Absolute Coordinate via Parameters.....	10-21
10.5.5	Use Communication to Access Absolute Position.....	10-21

### Note

A complete absolute servo system should include ASDA-B2-F servo drive, absolute motor and a backup battery box. With the battery that supplies power to the system, the encoder is able to work even when power is off. Moreover, absolute type of encoder can continuously record the motor's actual position anytime even when the motor shaft is rotated after power off. The absolute servo system must work with absolute motor. If it is arranged with an incremental type motor and the related parameters of absolute system are enabled, AL069 will occur.

**When using an absolute motor, as soon as it applies to the power, the motor speed should not exceed 250 rpm. When operating in battery mode, make sure the maximum speed does not exceed 200 rpm.**

Check if your motor is an absolute type of motor. See the model name below:

ECMA - □ A □ □ □ □ □ □  
 └─ A: absolute motor

Please correctly install the battery to the encoder. One servo drive uses one single battery box; while two servo drives can share one dual battery box. Please use Delta's encoder cable for connecting to Delta's battery box. See the following descriptions for the specifications of battery box and its accessories.

## 10.1 Absolute Type of Battery Box and Wiring Rods

### 10.1.1 Specifications

#### Precautions

Please carefully read through the following safety precautions. Use batteries in accordance with the specification so as to avoid damages or dangers.



- The installation location shall have no water drop, corrosive gas and inflammable gas.
- Correctly place the battery into battery box so as to avoid short circuiting.
- Do not short circuit the positive electrode and negative electrode of the battery; or install the battery in reverse direction.
- It is suggested to use new batteries only. This is for avoiding losing electric energy or shortening the lifetime of new batteries.
- Please follow the instructions when conduct wiring for battery box, or danger may occur.



- Do not place the battery in a high-temperature environment (over 100°C) or it might result in fire or explosion.
- It is non-rechargeable batteries. Do not charge the batteries or it might result in explosion.
- Do not directly weld on the surface of the battery.

#### Battery Specifications

Items	Li/SOCl <sub>2</sub> Cylindrical Battery
Type	ER14505
Delta Model Number	ASD-CLBT0100
International Standard Size	AA
Standard Voltage	3.6 V
Standard Capacity	2700 mAh
Maximum Continuous Discharge Current	100 mA
Maximum Pulse Current	200 mA
Dimensions (D x H)	14.5 x 50.5 mm
Weight	Approx. 19 g
Operating Temperature	-40 ~ +85 °C

Battery Life

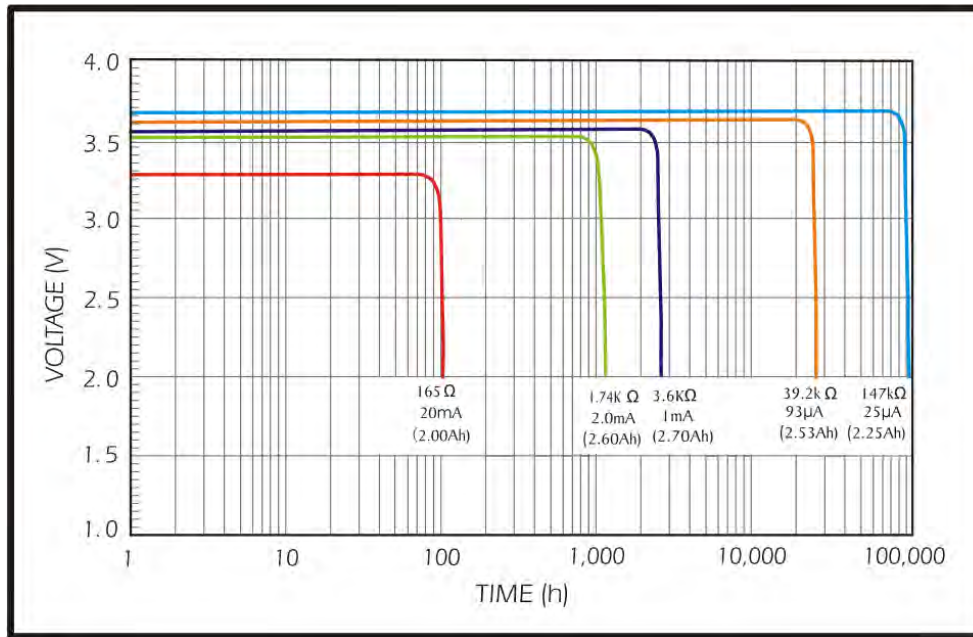

Figure 10.1.1 Curve of Discharge Current  
 (The above figure comes from EVE Energy Co. ER14505 Discharge Characteristics)

1. The above figure illustrates the discharge current curve generated by constant current test. According to the testing result shown on the graph above, when the power consumption of an absolute encoder is 65 uA or lower, if the voltage of the battery keeps 3 V or higher, the expected battery life is about 21900 hr, approximately 2.5 years<sup>(Note)</sup>. Therefore, the lowest voltage level of battery for an absolute encoder is set to 3.1 V.
2. The battery life expectancy is about 5 years and is able to provide 3.6 V or higher voltage under normal temperature and humidity conditions.

Note: The battery life was measured when one single battery box is connecting to one servo drive and one servo motor.

### 10.1.2 Battery Box Dimensions

Single battery box

Delta Part Number: ASD-MDBT0100

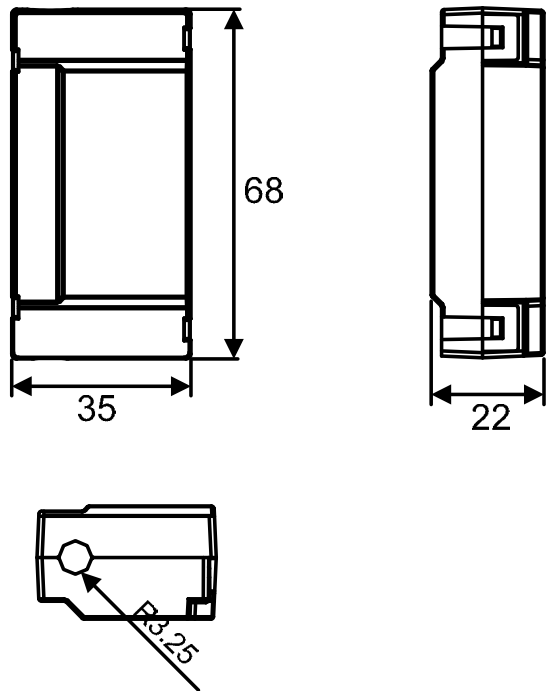

Weight
44 g

Unit: mm

Dual battery box

Delta Part Number: ASD-MDBT0200

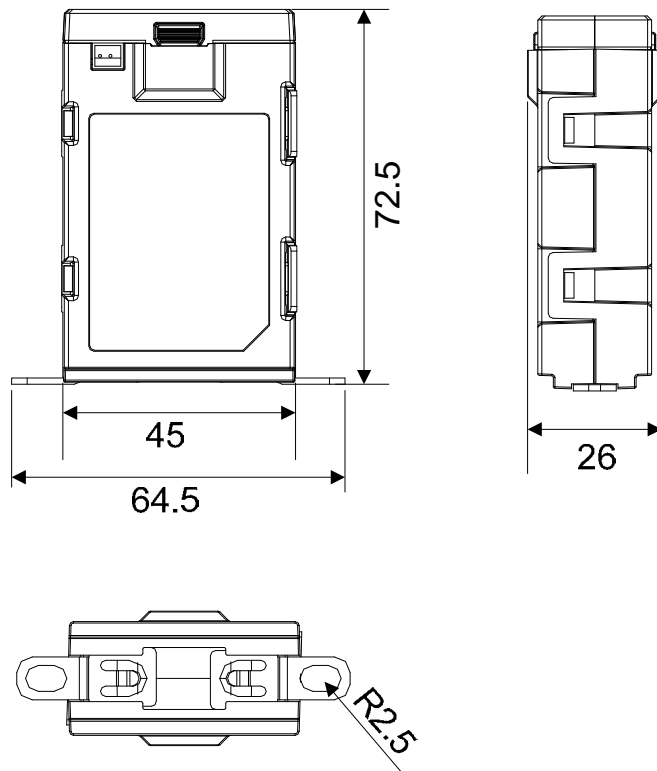

Weight
80 g

Unit: mm

### 10.1.3 Connection Cable for Absolute Encoder

A. Quick Connector

Delta Part Number: ASD-A2EB0003, ASD-A2EB0005

10

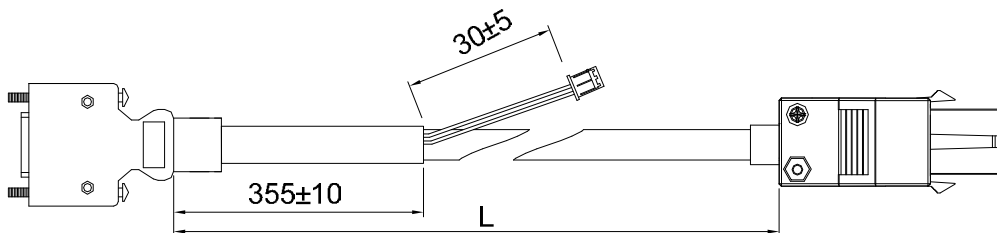

Title	Model Name	L	
		mm	inch
1	ASD-A2EB0003	3000 ± 100	118 ± 4
2	ASD-A2EB0005	5000 ± 100	197 ± 4

Connection method:

**Note** Please follow the instructions below when conduct wiring. Wrong wiring might result in explosion.

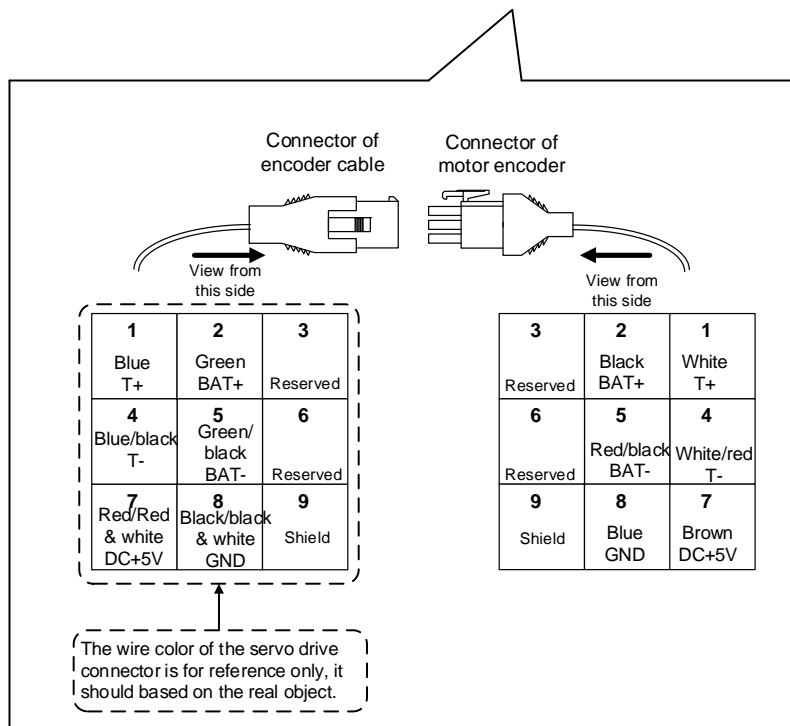
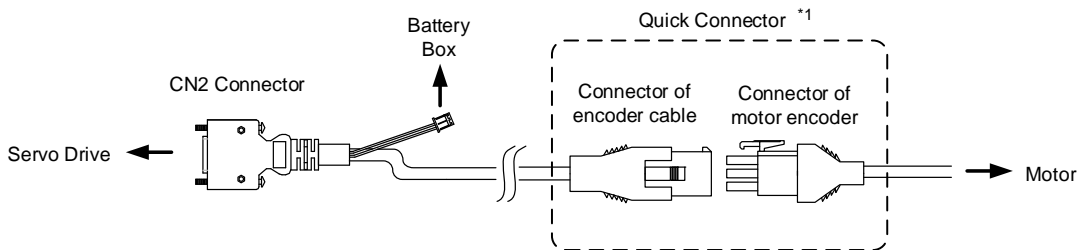

B. Military Connector

Delta Part Number: ASD-A2EB1003, ASD-A2EB1005

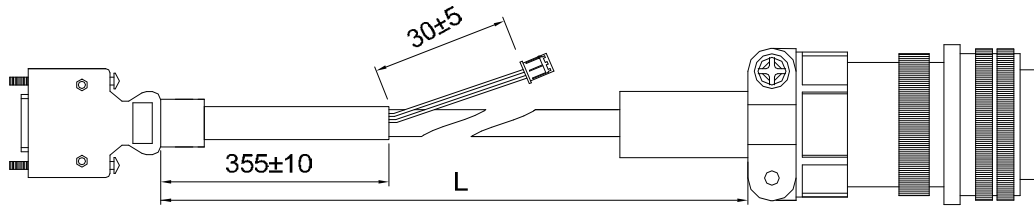

10

Title	Model Name	L	
		mm	inch
1	ASD-B2EB1003	3000 ± 100	118 ± 4
2	ASD-B2EB1005	5000 ± 100	197 ± 4

Connection method:

**Note** Please follow the instructions below when conduct wiring. Wrong wiring might result in explosion.

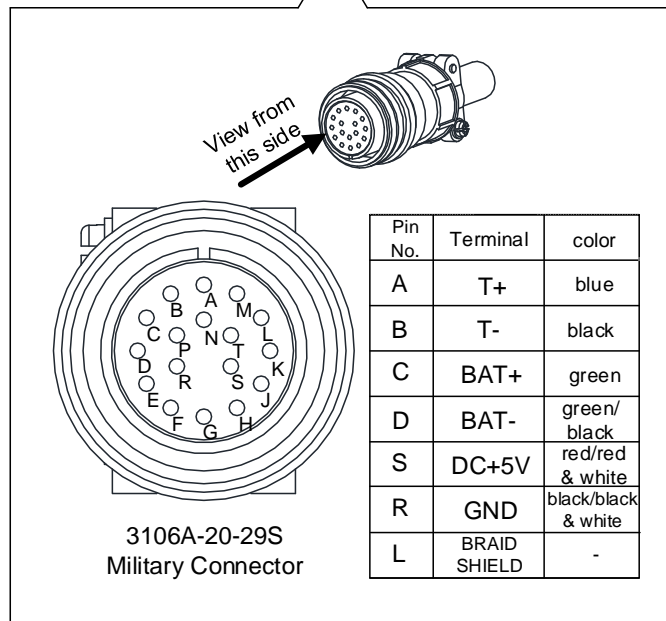
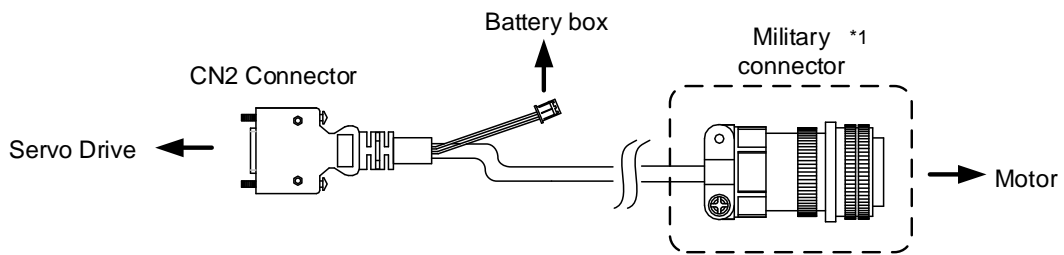

### 10.1.4 Battery Box Cable

Battery Box Cable AW  
Delta Part Number: 3864573700

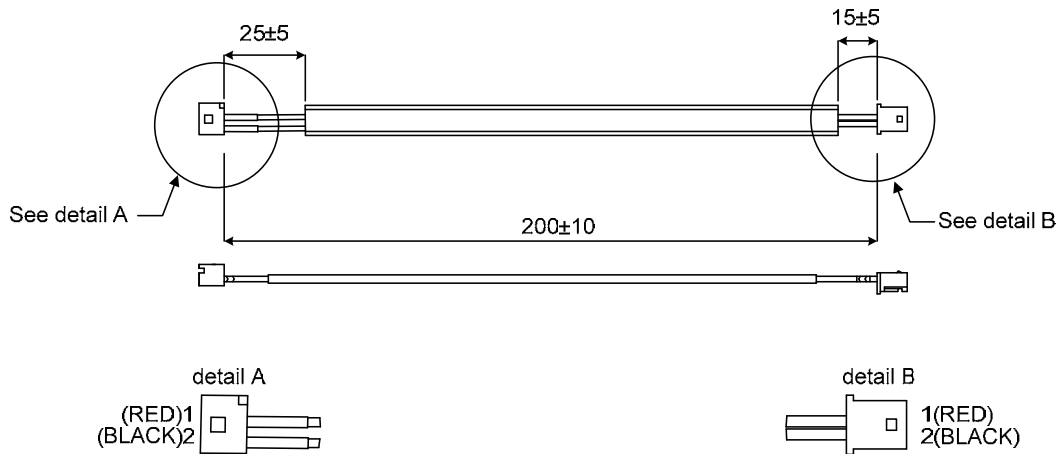

Battery Box Cable IW  
Delta Part Number: 3864811900

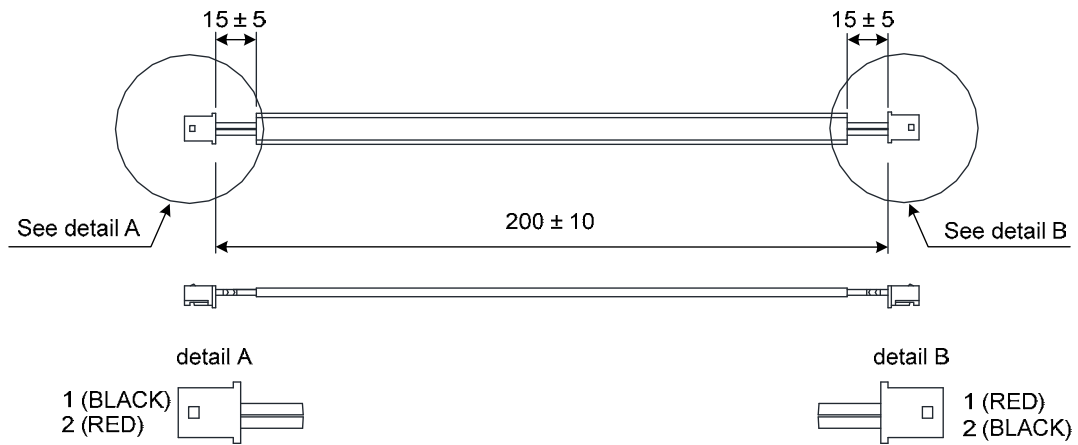

10

## 10.2 Installation

### 10.2.1 Install Battery Box in Servo System

Single Battery Box (Standard Wiring)

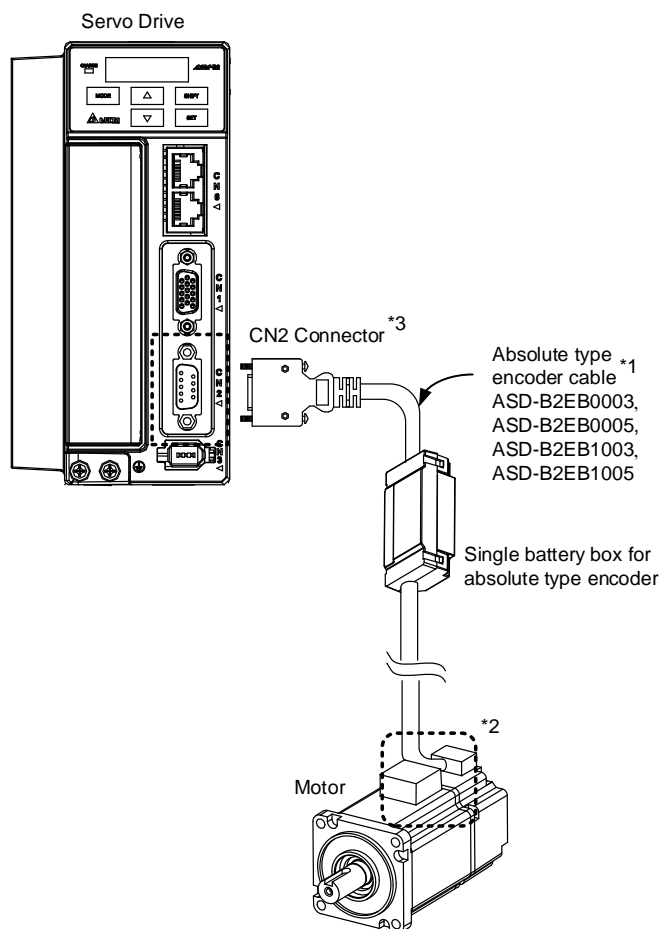

**Note:**

This is the wiring diagram of connecting to a single battery box, which is not drawn to scale. For different models of AC servo drive and motors, the connection cables may differ.

Please refer to section 10.1.3 for the wiring of \*1 and \*2.

\*3 Definition of CN2 connector:

Please follow the instructions below when conduct wiring. Wrong wiring might result in explosion.

CN2 Connector			Motor Connector	
Pin No	Terminal Symbol	Function and Description	Military Connector	Quick Connector
4	T+	Serial communication signal input / output (+)	A	1
5	T-	Serial communication signal input / output (-)	B	4
3	BAT+	Battery 3.6 V	C	2
2	BAT-	Battery ground	D	5
8	+5V	Power +5 V	S	7
6,7	GND	Power ground	R	8
Shell	Shield	Shield	L	9

Single Battery Box (Connect to CN4)

10

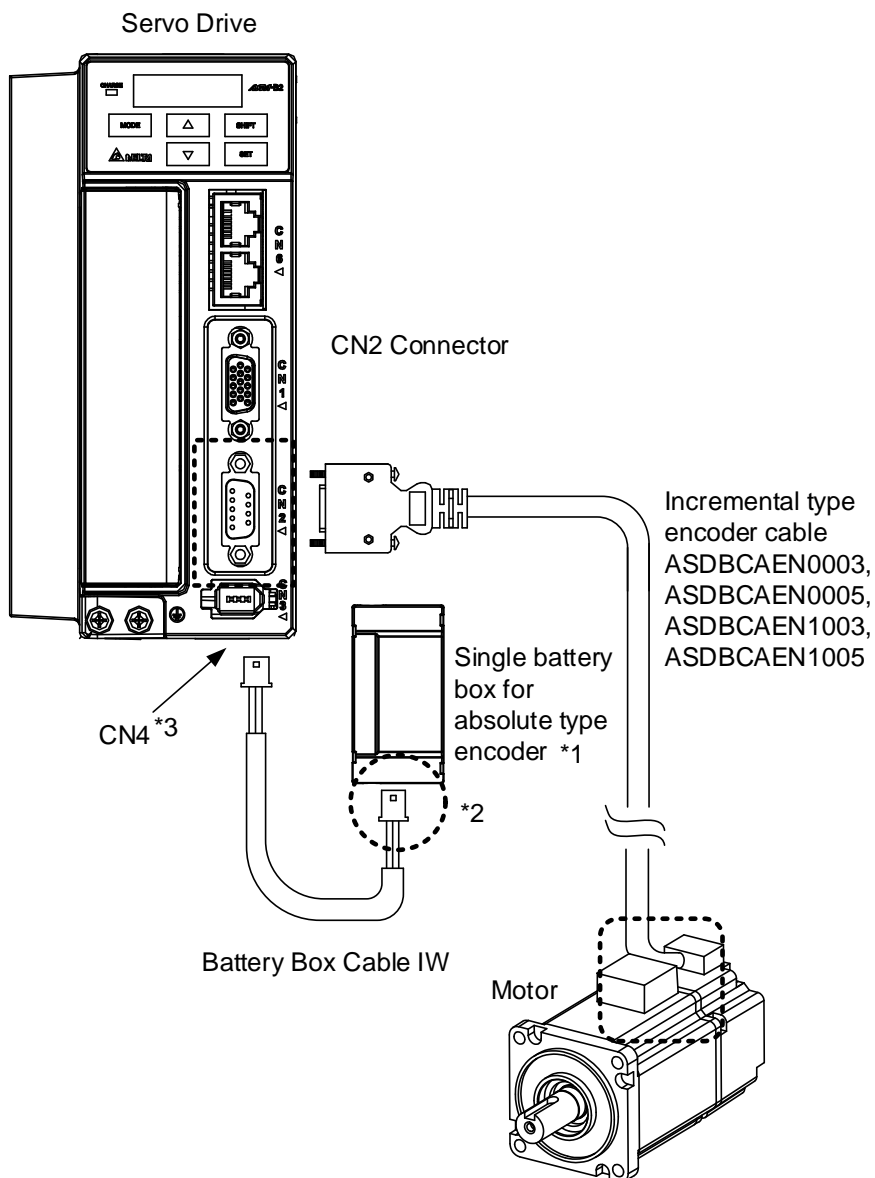

Note:

This is the wiring diagram of connecting to a single battery box, which is not drawn to scale. For different models of AC servo drive and motors, the connection cables may differ.

\*1 Make sure the battery box is firmly fixed.

\*2 Connect to the power based on single battery box. See descriptions below:

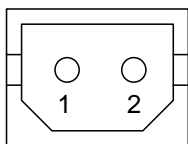

Pin No	Terminal Symbol	Connector Cable
1	BAT+	Red
2	BAT-	Black

\*3 Definition of CN4 connector:

Please follow the instructions below when conduct wiring. Wrong wiring might result in explosion.

Pin No	Terminal Symbol
1	BAT
2	BAT-

Dual Battery Box (Connect to CN2)

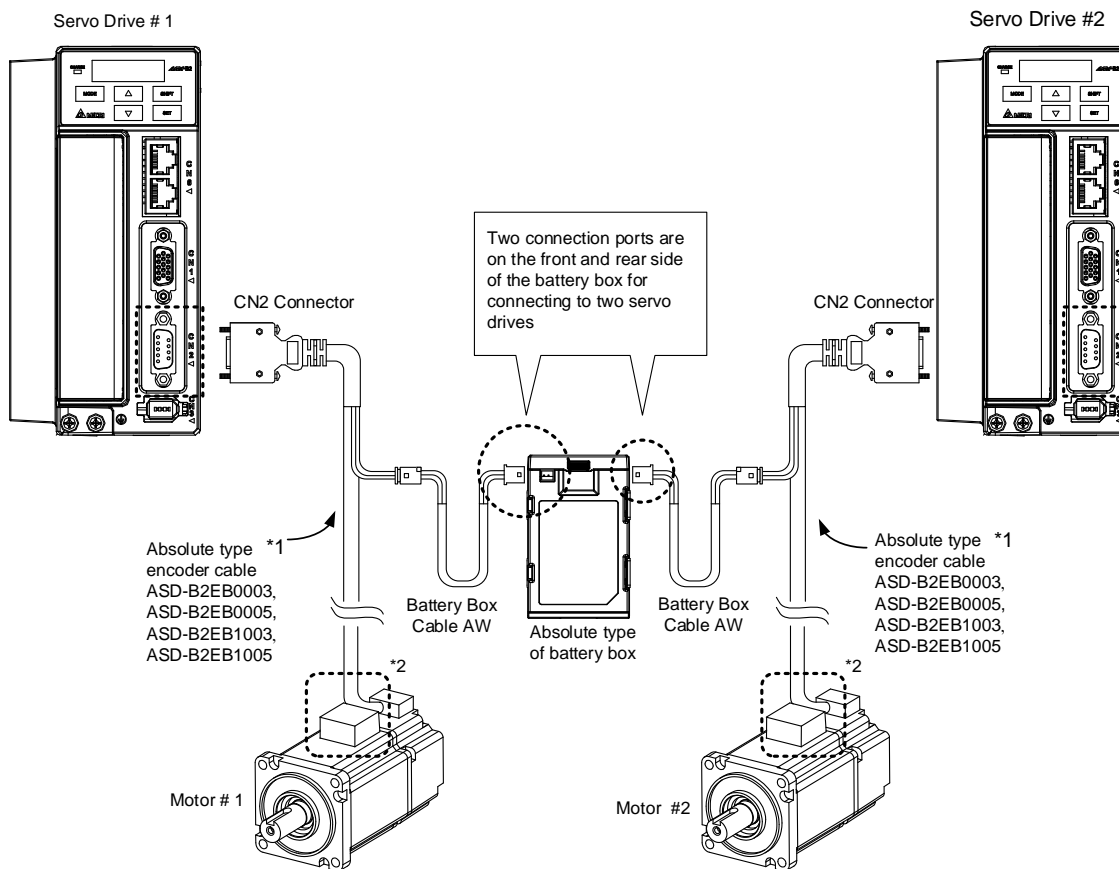

Note:

This is the wiring diagram of connecting to a dual battery box, which is not drawn to scale. For different models of AC servo drive and motors, the connection cables may differ.

Please refer to section 10.1.3 for the wiring of \*1 and \*2.

\*3 Definition of CN2 connector:

Please follow the instructions below when conduct wiring. Wrong wiring might result in explosion.

CN2 Connector			Motor Connector	
Pin No	Terminal Symbol	Function and Description	Military Connector	Quick Connector
4	T+	Serial communication signal input/output (+)	A	1
5	T-	Serial communication signal input/output (-)	B	4
3	BAT+	Battery 3.6 V	C	2
2	BAT-	Battery ground	D	5
8	+5V	Power +5 V	S	7
6, 7	GND	Power ground	R	8
Shell	Shield	Shield	L	9

Dual Battery Box (Connect to CN4)

10

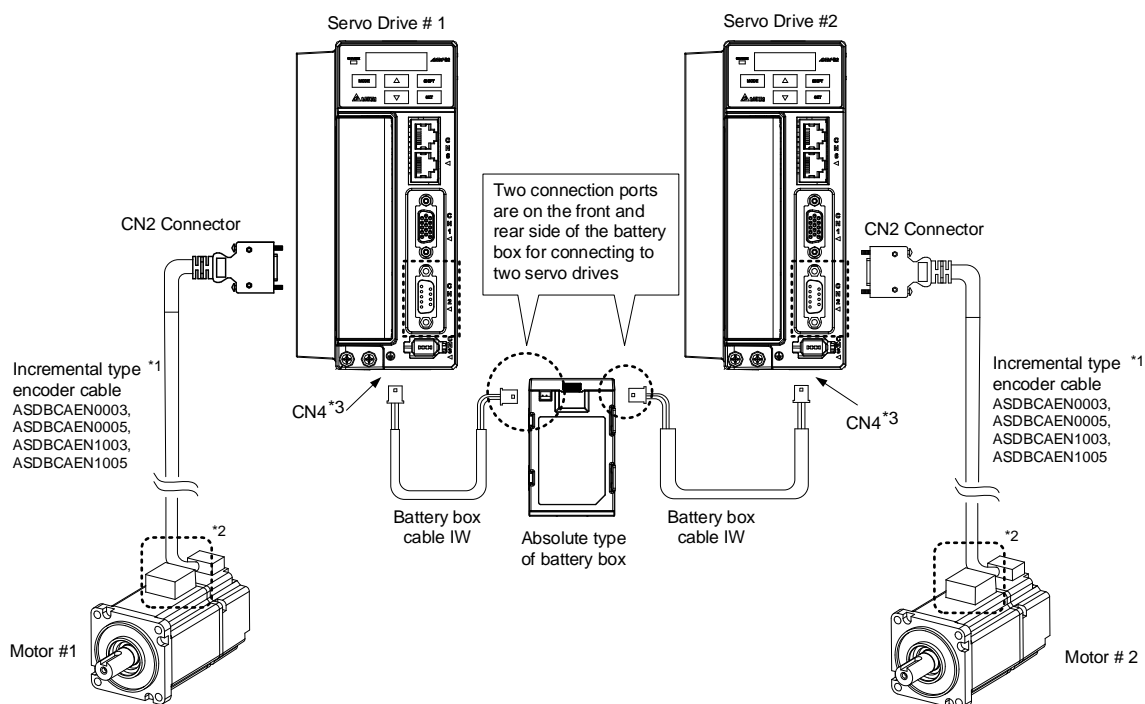

Note:

This is the wiring diagram of connecting to a dual battery box, which is not drawn to scale. For different models of AC servo drive and motors, the connection cables may differ.

Please refer to section 10.1.3 for the wiring of \*1 and \*2.

\*3 Definition of CN4 connector:

Please follow the instructions below when conduct wiring. Wrong wiring might result in explosion.

Pin No	Terminal Symbol
1	BAT+
2	BAT-

### 10.2.2 How to Install the Battery

#### Single Battery Box

Loosen the hooks on both sides to open the lid of battery box.

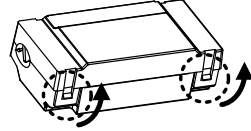

Put the metal clip on connection cable. Please note that the metal clip should be put close to the heat shrink.

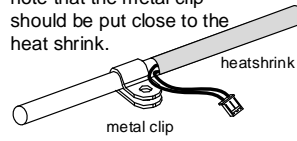

10

- ① Plug the connection cable
- ② Tighten the screw

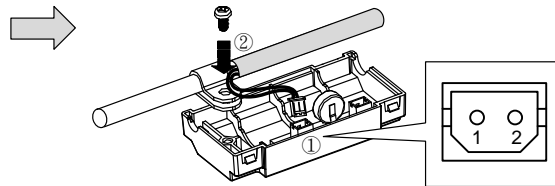

Install a new battery and connect it to the cable

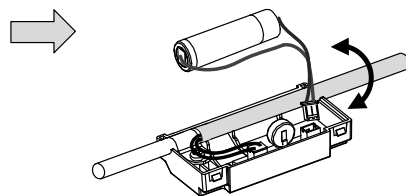

Place the cable into the box and cover the lid back.

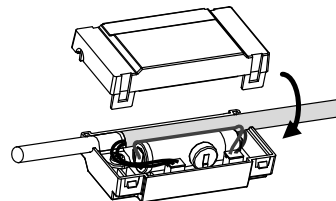

#### Dual Battery Box

Pull the retaining rings from the bottom of the battery box. See the figure below.

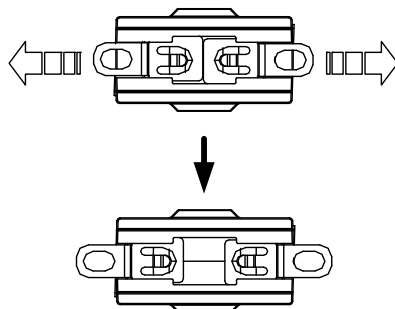

Tighten the screws to secure the battery box.

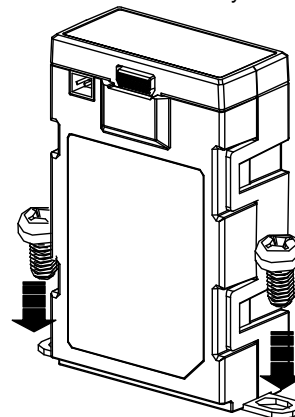

### 10.2.3 How to Replace a Battery

When AL061 occurs, it means the voltage is too low (See the detailed descriptions in Chapter 9). Users can use P0-02 to check the battery power. When it displays 31, it means the voltage is under 3.1 V. For avoiding data loss, please replace a new battery.

When the voltage is under 2.7 V, motor's position record might be lost. Please conduct homing after replacing a new battery. Please refer to Chapter 9 for further information.

**Note** For avoiding data loss, it is recommended to replace the new battery when the servo drive still has power supply.

#### Single Battery Box

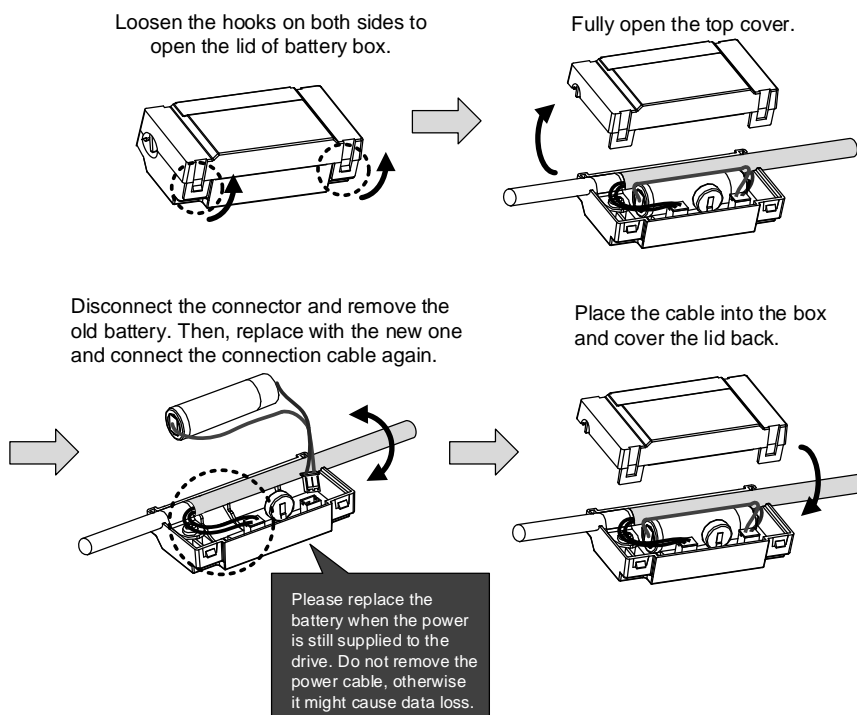

### Dual Battery Box

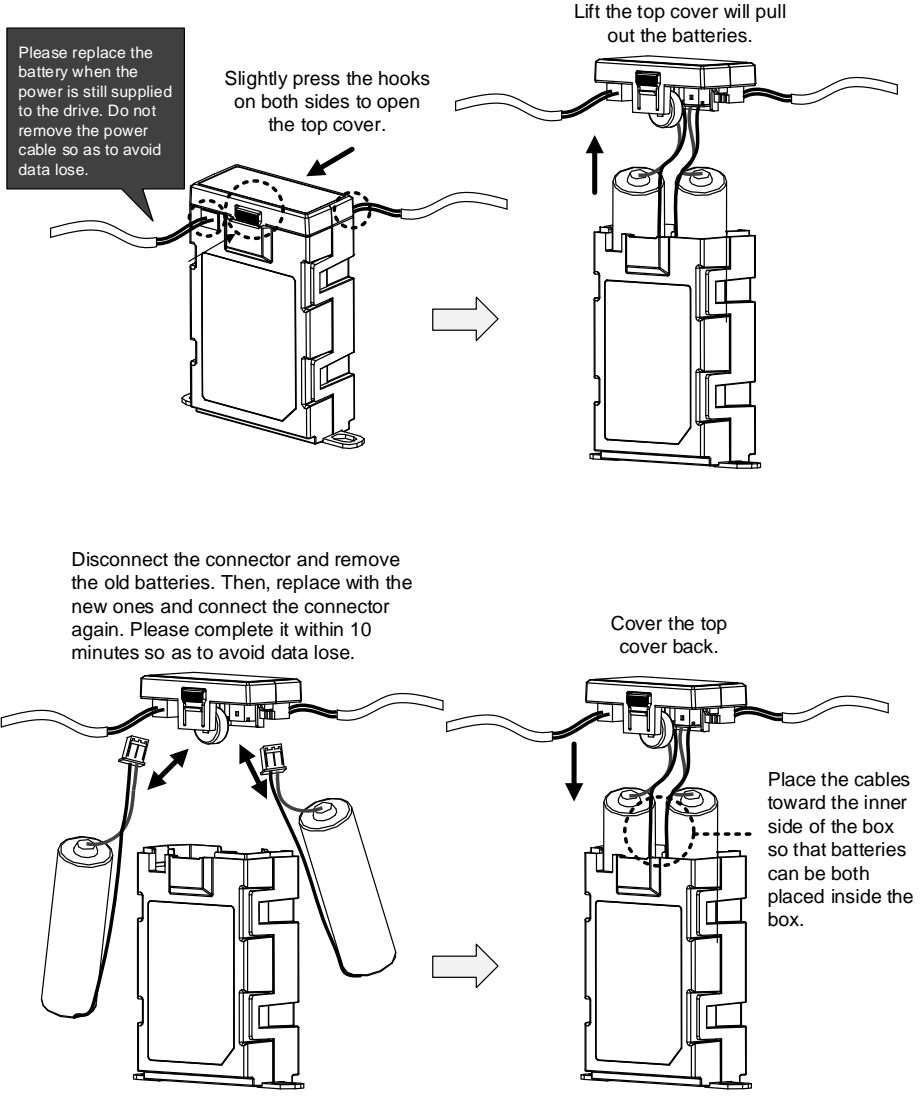

10

### 10.3 Parameters Related to Absolute Servo System

Parameter Number	Abbr.	Function
P0-02	STS	Drive Status
P0-49	UAP	Renew Encoder Absolute Position
P0-50	APSTS	Absolute Coordinate System Status
P0-51	APR	Encoder Absolute Position (Multiturn)
P0-52	APP	Encoder Absolute Position (Pulse number within Single Turn or PUU)
P2-69	ABS	Absolute Encoder Setting
P2-70	MRS	Read Data Format Selection
P2-71	CAP	Absolute Position Homing

10

## 10.4 Servo Drive Alarm List for Absolute Function and Monitoring Variables

Display	Alarm Name	Alarm Description
AL028	Encoder voltage error or the internal of the encoder is in error	Charging circuit of the servo drive is not removed and the battery voltage is higher than the specification (>3.8 V) or the encoder signal is in error.
AL029	Gray code error	Absolute position is in error.
AL034	Internal communication of the encoder is in error	1. Internal communication error of the absolute encoder. 2. Internal error of other type of encoder.
AL060	The absolute position is lost	Due to battery undervoltage or the failure of power supply, the encoder lost the internal record.
AL061	Encoder under voltage	The voltage of the absolute encoder is lower than the specification.
AL062	The multi-turn of absolute encoder overflows	The multi-turn of absolute encoder exceeds the maximum range: -32768 ~ +32767
AL069	Wrong motor type	Incremental motor is not allowed to activate the absolute function.
AL289	Feedback position counter overflows	Feedback position counter overflows.

### Related Monitoring Variables

Code	Name of Variables	Description
038 (26h)	Voltage level of battery	The voltage level of battery for an absolute encoder.

10

## 10.5 System Initialization and Operation Procedures

### 10.5.1 System Initialization

After the servo system resumes operation, the host controller can acquire motor's current absolute position via communication, such as RS-232. Delta's absolute system provides two kinds of position value for the host controller, pulse and PUU.

AL060 will occur when the absolute system is enabled for the first time. This is because the coordinate system has not been created. The alarm will be cleared until the setting of coordinate system is complete. Not enough battery power or the failure of power supply will lead to coordinate system loss and the occurrence of AL060. When the motor's rotating number exceeds the range from -32768 to 32767, AL062 will occur. In terms of PUU, the position value should be between -2147483648 and 2147483647, or AL289 will occur.

Apart from the alarms that mentioned above, P2-70 can be used to setup Delta's absolute servo system. AL062 and AL289 can be set not to show when the absolute coordinate system overflows (the cycle number exceeds the range between -32768 and 32767 or PUU exceeds the range from -2147483648 to 2147483647). This is for the system that uses incremental command to operate in single direction.

Parameters setting:

1. Initialize the absolute coordinates. When the setting of coordinate is complete, AL060 will be cleared automatically. Operation mode: Please refer to section 10.5.4 for initializing the absolute coordinates via parameters.
2. When the system is re-power on, users can access absolute position for the host controller via communication (Please refer to section 10.5.5). Through the setting of P2-70, the host controller can select the accessing value, value of PUU (please refer to section 10.5.3) or the pulse value of 1280000 within one cycle (please refer to 10.5.2).

### 10.5.2 Pulse Number

When the motor is running in clockwise direction, the cycle number is defined as a negative value; when it is in counter clockwise operation, it is defined as a positive value. Range of the maximum counting number is from -32768 to +32767. AL062 will occur when the cycle number exceeds the range (overflows). For conquering the problem, users have to re-initialize the coordinates to clear AL062. If P2-70 has been set not to show any alarm when overflows, then the system will ignore the problem when the cycle number exceeds the range. If the system is operating in counter clockwise direction, when the cycle number reaches 32767 and moves to the target position, the value will turn to -32768. If it keeps rotating, the sequence of the cycle number will be -32768, -32767, -32766 and so on and vice versa when rotating in clockwise direction.

In addition, there are 1280000 pulses (0 ~ 1279999) in one rotation. Please pay attention to its direction. The cycle number and pulse number can be read via communication.

Pulse number = m (cycle) × 1280000 + pulse number (0 ~ 1279999)

Following shows the conversion between pulse number and PUU:

When the rotation direction is CCW defined by P1-01, then PUU number = pulse number ×  $\frac{P1-45}{P1-44}$  + P6-01

When the rotation direction is CW defined by P1-01, then PUU number = (-1) × pulse number ×  $\frac{P1-45}{P1-44}$  + P6-01

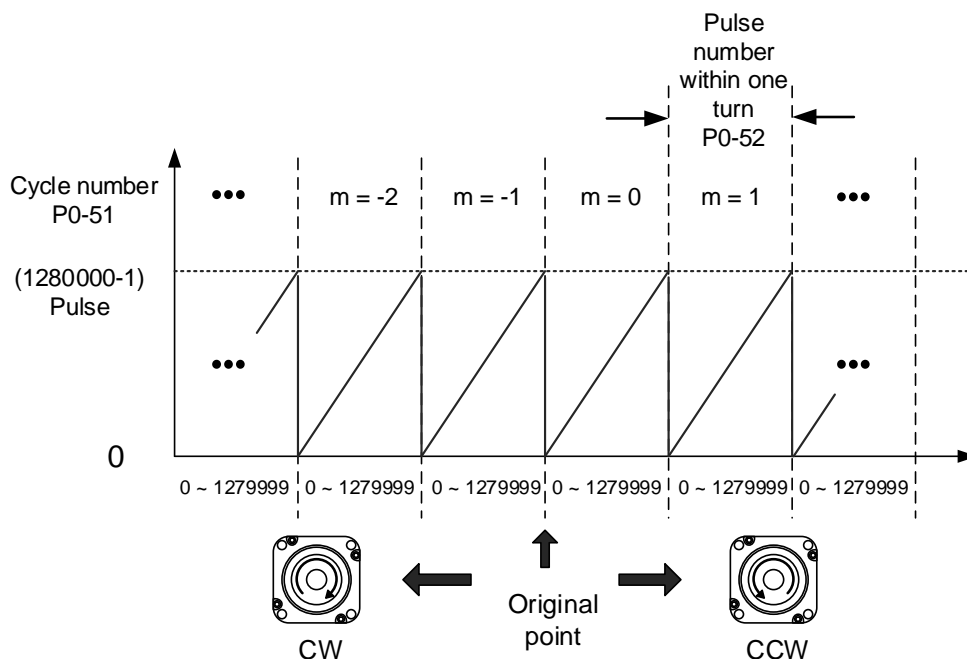

Figure 10.5.2.1 Absolute position of pulse counting

### 10.5.3 PUU Number

A 32 bits number with sign is used to denote PUU number in an absolute system. The PUU number is increasing when the motor runs in forward direction and decreasing for a reverse direction. The motor's rotating direction is defined by the setting of P1-01.Z. In a word, the feedback value of the encoder can be used to distinguish the rotating direction. The increasing feedback value means the motor rotating in forward direction while the decreasing feedback number represents reverse direction.

If the motor keeps rotating in one direction, AL062 will occur once its rotating number exceeds the range between -32768 and +32767. And AL289 occurs when motor's PUU number exceeds the range from -2147483648 to 2147483647. Once AL063 or AL289 occurs, users will have to initialize the coordinates to clear the alarm. Parameter P2-70 can be used to determine the overflowing range so as to avoid the occurrence of AL063 and AL289. When the motor rotates in forward direction and exceeds the range of PUU, once the rotating number reaches 2147483647, the value will turn to -2147483648. If it keeps rotating, the sequence of the cycle number will be -2147483647, -2147483646 so on and vice versa when rotating in clockwise direction.

See the following examples for counting overflows.

Example 1:

When P1-44 = 128 and P1-45 = 10, then the motor needs 100000 PUU to run a cycle.  $2147483647 \div 100000 \approx 21474.8$ . Once the motor runs over 21474.8 (< 32767) cycles in forward direction, AL289 will occur.

Example 2:

When P1-44 = 128 and P1-45 = 1, then the motor needs 10000 PUU to run a cycle.  $2147483647 \div 10000 \approx 214748.3$ . Once the motor runs over 32767(<214748.3) cycles in forward direction, AL062 will occur.

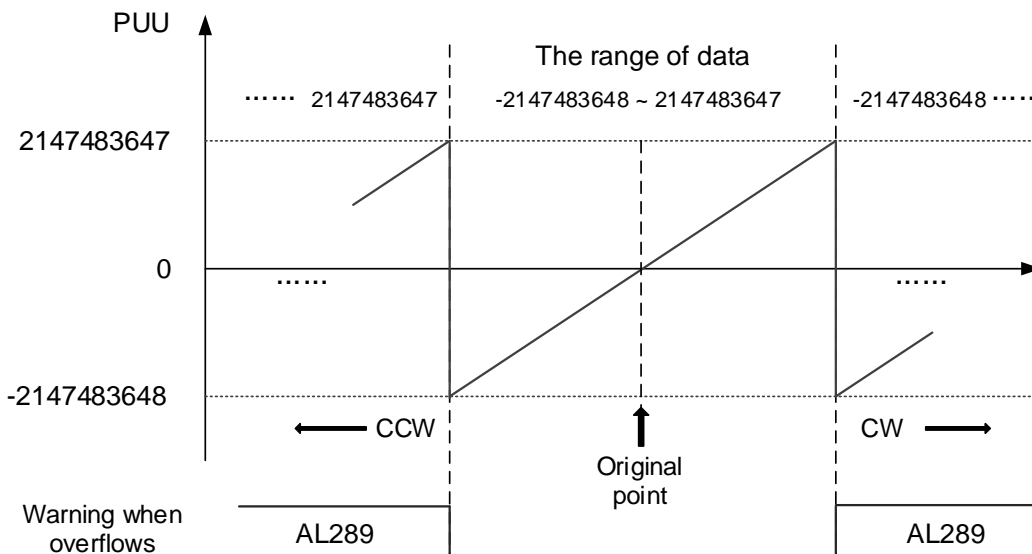

Figure 12-2 PUU counting in absolute coordinate system

Note:  
After initializing the absolute coordinates, changing the setting of parameter P1-01.Z or E-gear ratio (P1-44, P1-45) will cause functional failure of the absolute coordinates and users have to initialize the coordinates again.

### 10.5.4 To Initialize the Absolute Coordinate via Parameters

Users can set P2-71 to 1 to initialize the coordinates via panel or communication. As long as P2-71 is set to 1, the absolute system will be reset. Since the write-in function of P2-71 is protected by P2-08, users have to set P2-08 to 271 first. Please note that this method can be applied to others modes except DMCNET. For DMCNET mode, please do homing to reset the coordinate.

### 10.5.5 Use Communication to Access Absolute Position

Through the setting of P0-49 via communication, the servo drive can update the encoder status and the motor's absolute position to P0-50, P0-51 and P0-52. Through bit 1 setting of P2-70, users can determine the accessing data type, pulse or PUU.

As the motor stands still, it still slightly moves forward and backward. When P0-49 is set to 1, it will read the exact position where the motor stops without changing anything. On the other hand, when P0-49 is set to 2, the motor's current position will be updated to the servo drive (which means to clear the position error). For example, if the motor's current position is at 20000, but it stays around 19999 and 20001. If issuing the command to read the motor's position when motor stops at 20001, then the motor's position will be updated to 20001.

After all position is updated to P0-50 ~ P0-52, P0-49 will be reset to 0 automatically. Then, the controller can access the value of P0-50 ~ P0-52. P0-50 shows the status of absolute type of encoder. When it shows absolute position lost or overflows, the accessed absolute position is invalid. Users have to do homing and initialize the coordinate.

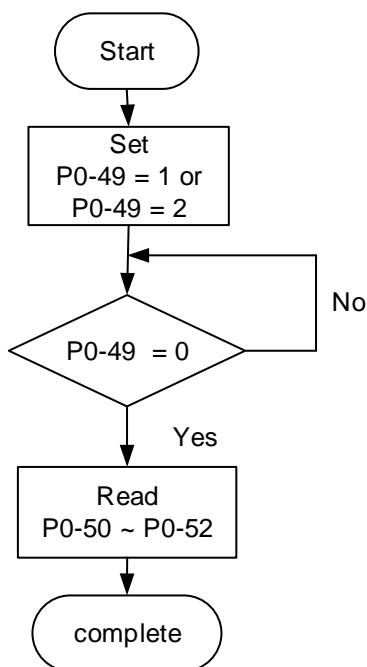

(This page is intentionally left blank.)

10

# Specifications Appendix

---

# A



Specifications of ASDA-B2-F Servo Drive.....	A-2
Specifications of Servo Motors (ECMA Series) .....	A-4
Torque Features (T-N Curves) .....	A-13
Overload Features .....	A-15
Dimensions of Servo Drive .....	A-17
Dimensions of Servo Motor.....	A-21

## Specifications of ASDA-B2-F Servo Drive

A

Watt/Kilowatt		100	200	400	750	1 k	1.5 k	2 k	3 k	
		01	02	04	07	10	15	20	30	
Power	Phase/Voltage	Three-phase: 170 ~ 255 VAC, 50/60 Hz $\pm 5\%$ Single-phase: 200 ~ 255 VAC, 50/60 Hz $\pm 5\%$					Three-phase 170 ~ 255 VAC, 50/60Hz $\pm 5\%$			
	Input Current (3PH) Unit: Arms	0.7	1.11	1.86	3.66	4.68	5.9	8.76	9.83	
	Input Current (1PH) Unit: Arms	0.9	1.92	3.22	6.78	8.88	10.3	-	-	
	Continuous Output Current Unit: Arms	0.9	1.55	2.6	5.1	7.3	8.3	13.4	19.4	
Cooling Method		Natural cooling				Fan cooling				
Encoder Resolution (Servo Drive Resolution)		20-bit (1280000 p/rev)								
Main Circuit Control		SVPWM control								
Control Mode		Manual / Auto								
Regenerative Resistor		None		Built-in						
Position Control Mode	Command Source	DMCNET mode								
	Smoothing Strategy	Low-pass filter								
	E-Gear Ratio	E-Gear ratio N / M multiple (1/50 < N/M < 25600) N: 1 ~ (2 <sup>26</sup> -1) / M: 1 ~ (2 <sup>31</sup> -1)								
	Torque Limit	Parameter settings								
	Feed Forward Compensation	Parameter settings								
Speed Control Mode	Speed Control Range <sup>*1</sup>	1:5000								
	Command Source	Internal register								
	Smoothing Strategy	Low-pass and S-curve filter								
	Torque Limit	Parameter settings								
	Bandwidth	Max. 550 Hz								
	Speed Accuracy <sup>*2</sup>	Load fluctuation 0 ~ 100%, Max. 0.01% Power fluctuation $\pm 10\%$ , Max. 0.01% Ambient temperature fluctuation 0 ~ 50 °C, Max 0.01%								
Torque Control Mode	Command Source	Internal register								
	Smoothing Strategy	Low-pass filter								
	Speed Limit	Parameter settings								

A

Watt/Kilowatt		100	200	400	750	1 k	1.5 k	2 k	3 k
		01	02	04	07	10	15	20	30
Digital Input/Output	Input	Alarm reset, Gain switching, Speed command selection, Emergency stop, Forward/Reverse inhibit limit and Forward/Reverse operation torque limit. *DIs mentioned above are only available for Non-DMCNET mode. In DMCNET mode, it is suggested to use communication for DI input and DI functions of emergency stop, forward/reverse inhibit limit and homing.							
	Output	A, B Line Driver output Servo ready, Servo on, Zero speed reached, Target speed reached, Target position completed, Torque limiting, Servo alarm, Brake control, Early warning for overload, Servo warning							
Protective Function		Over current, Over voltage, Under voltage, Overheat, Overload* <sup>3</sup> , Excessive speed deviation, Excessive position deviation, Encoder error, Regeneration error, Communication error, Register error, Short-circuit protection of terminal U, V, W and CN1, CN2, CN3							
Communication Interface		RS-232							
Environment	Installation Site	Indoors (avoid direct sunlight), no corrosive fog (avoid fume, flammable gas and dust)							
	Altitude	1000 m or lower (above sea level)							
	Atmospheric Pressure	86 kPa ~ 106 kPa							
	Ambient Temperature	0 °C ~ 55 °C (If ambient temperature is above 45 °C, forced cooling will be required)							
	Storage Temperature	-20 °C ~ 65 °C							
	Humidity	0 ~ 90% RH below (non-condensing)							
	Vibration	9.80665 m/s <sup>2</sup> (1 G), less than 20 Hz 5.88 m/s <sup>2</sup> (0.6 G), 20 to 50 Hz							
	IP Rating	IP20							
	Power System	TN system* <sup>4</sup>							
	Approvals	IEC/EN 61800-5-1, UL508C   US LISTED							

Note:

- \*1 With rated load, the speed ratio is: the minimum speed (smooth operation) / rated speed.
- \*2 When the command is the rated speed, the velocity correction ratio is: (rotation speed without load – rotation speed with full load) / rated speed.
- \*3 Please refer to page A-16 for overload features.
- \*4 TN system: The neutral point of the power system connects to the ground directly. The exposed metal components connect to the ground via protective earth conductor.
- \*5 2 kW, 3 kW models are scheduled to be released.

## Specifications of Servo Motors (ECMA Series)

### Low Inertia Series

A

Model ECMA	C104	C△04	C△06		C△08		C△09	
	0F	01	02	04□ S	04	02	04	04
Rated Power (kW)	0.05	0.1	0.2	0.4	0.4	0.75	0.75	1.0
Rated Torque (N-m) <sup>*1</sup>	0.159	0.32	0.64	1.27	1.27	2.39	2.39	3.18
Max. Torque (N-m)	0.477	0.96	1.92	3.82	3.82	7.16	7.14	8.78
Rated Speed (r/min)	3000						3000	
Max. Speed (r/min)	5000						3000	
Rated Current (A)	0.69	0.90	1.55	2.60	2.60	5.10	3.66	4.25
Max. Instantaneous Current (A)	2.05	2.70	4.65	7.80	7.80	15.3	11	12.37
Max. Power Rating (kW/s)	12.27	27.7	22.4	57.6	24.0	50.4	29.6	38.6
Rotor Inertia (× 10 <sup>-4</sup> kg.m <sup>2</sup> )	0.0206	0.037	0.177	0.277	0.68	1.13	1.93	2.62
Mechanical Constant (ms)	1.2	0.75	0.80	0.53	0.74	0.63	1.72	1.20
Torque Constant-KT (N-m/A)	0.23	0.36	0.41	0.49	0.49	0.47	0.65	0.75
Voltage Constant-KE (mV/(r/min))	9.8	13.6	16.0	17.4	18.5	17.2	24.2	27.5
Armature Resistance (Ohm)	12.7	9.30	2.79	1.55	0.93	0.42	1.34	0.897
Armature Inductance (mH)	26	24.0	12.07	6.71	7.39	3.53	7.55	5.7
Electric Constant (ms)	2.05	2.58	4.30	4.30	7.96	8.36	5.66	6.35
Insulation Class	Class A (UL), Class B (CE)							
Insulation Resistance	>100 MΩ, DC 500 V							
Insulation Strength	1.8k Vac, 1 sec							
Weight (without brake) (kg)	0.42	0.5	1.2	1.6	2.1	3.0	2.9	3.8
Weight (with brake) (kg)	--	0.8	1.5	2.0	2.9	3.8	3.69	5.5
Max. Radial Load (N)	78.4	78.4	196	196	245	245	245	245
Max. Axial Load (N)	39.2	39.2	68	68	98	98	98	98
Max. Power Rating (kW/s) (with brake)	--	25.6	21.3	53.8	22.1	48.4	29.3	37.9
Rotor Inertia (× 10 <sup>-4</sup> kg.m <sup>2</sup> ) (with brake)	--	0.04	0.19	0.30	0.73	1.18	1.95	2.67
Mechanical constant (ms) (with brake)	--	0.81	0.85	0.57	0.78	0.65	1.74	1.22
Brake Holding Torque [Nt-m (min)] <sup>*2</sup>	--	0.3	1.3	1.3	2.5	2.5	2.5	2.5
Brake Power Consumption (at 20°C) [W]	--	7.3	6.5	6.5	8.2	8.2	8.2	8.2
Brake Release Time [ms (Max)]	--	5	10	10	10	10	10	10
Brake Pull-in Time [ms (Max)]	--	25	70	70	70	70	70	70

Vibration Grade ( $\mu\text{m}$ )	15
Operating Temperature ( $^{\circ}\text{C}$ )	$0^{\circ}\text{C} \sim 40^{\circ}\text{C}$
Storage Temperature ( $^{\circ}\text{C}$ )	$-10^{\circ}\text{C} \sim 80^{\circ}\text{C}$
Operating Humidity	20 ~ 90%RH (non-condensing)
Storage Humidity	20 ~ 90%RH (non-condensing)
Vibration Capacity	2.5 G
IP Rating	IP65 (when waterproof connectors are used, or when an oil seal is used to be fitted to the rotating shaft (an oil seal model is used))
Approvals	

A

ECMA Series	C $\Delta$ 10		C $\Delta$ 13
	10	20	30
Rated Power (kW)	1.0	2.0	3.0
Rated Torque (N-m) <sup>*1</sup>	3.18	6.37	9.55
Max. Torque (N-m)	9.54	19.1	28.65
Rated Speed (r/min)	3000		3000
Max. Speed (r/min)	5000		4500
Rated Current (A)	7.30	12.05	17.2
Max. Instantaneous Current (A)	21.9	36.15	47.5
Max. Power Rating (kW/s)	38.1	90.6	71.8
Rotor Inertia ( $\times 10^{-4}\text{kg}\cdot\text{m}^2$ )	2.65	4.45	12.7
Mechanical Constant (ms)	0.74	0.61	1.11
Torque constant-KT (N-m/A)	0.44	0.53	0.557
Voltage Constant-KE (mV / (r/min))	16.8	19.2	20.98
Armature Resistance (Ohm)	0.20	0.13	0.0976
Armature Inductance (mH)	1.81	1.50	1.21
Electric Constant (ms)	9.30	11.4	12.4
Insulation Class	Class A (UL), Class B (CE)		
Insulation Resistance	>100 M $\Omega$ , DC 500 V		
Insulation Strength	1.8k Vac, 1 sec		
Weight (kg) (without brake)	4.3	6.2	7.8
Weight (kg) (with brake)	4.7	7.2	9.2
Max. Radial Load (N)	490	490	490
Max. Axial Load (N)	98	98	98
Max. Power Rating (kW/s)(with brake)	30.4	82.0	65.1

A

ECMA Series	C△10		C△13
	10	20	30
Rotor Inertia ( $\times 10^{-4} \text{kg.m}^2$ ) (with brake)	3.33	4.95	14.0
Mechanical Constant (ms) (with brake)	0.93	0.66	1.22
Brake Holding Torque [Nt-m (min)] <sup>*2</sup>	8.0	8.0	10.0
Brake Power Consumption (at 20°C) [W]	18.7	18.7	19.0
Brake Release Time [ms (Max)]	10	10	10
Brake Pull-in Time [ms (Max)]	70	70	70
Vibration Grade ( $\mu\text{m}$ )	15		
Operating Temperature (°C)	0°C ~ 40°C		
Storage Temperature (°C)	-10°C ~ 80°C		
Operating Humidity	20 ~ 90%RH (non-condensing)		
Storage Humidity	20 ~ 90%RH (non-condensing)		
Vibration Capacity	2.5 G		
IP Rating	IP65 (when waterproof connectors are used, or when an oil seal is used to be fitted to the rotating shaft (an oil seal model is used))		
Approvals			

Note:

- \*1 The rated torque is the continuous permissible torque between 0~40°C operating temperature when attaching with the following heat sink dimension:  
 ECMA-\_\_ 04 / 06 / 08: 250 mm x 250 mm x 6 mm  
 ECMA-\_\_ 10: 300 mm x 300 mm x 12 mm  
 ECMA-\_\_ 13: 400 mm x 400 mm x 20 mm  
 ECMA-\_\_ 18: 550 mm x 550 mm x 30 mm  
 Material: Aluminum – F40, F60, F80, F100, F130, F180
- \*2 The built-in brake of the servo motor is for remaining the item in stop status. Do not use it to decelerate or as the dynamic brake.
- \*3 For servo motor with magnetic encoder, please refer to the standard specifications of servo motors.
- \*4 The box (△) in the column stands for encoder type, please refer to Chapter 1 for detailed description.

## Medium/High Inertia Series

ECMA Series	E△13				E△18		F△13		F△18
	05	10	15	20	20	30	08	13	30
Rated Power (kW)	0.5	1.0	1.5	2.0	2.0	3.0	0.85	1.3	3.0
Rated Torque (N-m) <sup>*1</sup>	2.39	4.77	7.16	9.55	9.55	14.32	5.41	8.34	19.10
Max. Torque (N-m)	7.16	14.32	21.48	28.65	28.65	42.97	13.8	23.3	57.29
Rated Speed (r/min)	2000						1500		
Max. Speed (r/min)	3000						3000		
Rated Current (A)	2.9	5.6	8.3	11.01	11.22	16.1	7.1	12.6	19.4
Max. Instantaneous Current (A)	8.7	16.8	24.90	33.03	33.66	48.3	19.4	38.6	58.2
Max. Power Rating (kW/s)	7.0	27.1	45.9	62.5	26.3	37.3	21.52	34.78	66.4
Rotor Inertia ( $\times 10^{-4}$ kg.m <sup>2</sup> )	8.17	8.41	11.18	14.59	34.68	54.95	13.6	20	54.95
Mechanical Constant (ms)	1.91	1.51	1.11	0.96	1.62	1.06	2.43	1.62	1.28
Torque Constant-KT (N-m/A)	0.83	0.85	0.87	0.87	0.85	0.89	0.76	0.66	0.98
Voltage Constant-KE (mV/(r/min))	30.9	31.9	31.8	31.8	31.4	32.0	29.2	24.2	35.0
Armature Resistance (Ohm)	0.57	0.47	0.26	0.174	0.119	0.052	0.38	0.124	0.077
Armature Inductance (mH)	7.39	5.99	4.01	2.76	2.84	1.38	4.77	1.7	1.27
Electric Constant (ms)	12.96	12.88	15.31	15.86	23.87	26.39	12.55	13.71	16.51
Insulation Class	Class A (UL), Class B (CE)								
Insulation Resistance	>100 MΩ, DC 500 V								
Insulation Strength	AC 1500 V, 60 sec								
Weight (kg) (without brake)	6.8	7.0	7.5	7.8	13.5	18.5	8.6	9.4	18.5
Weight (kg) (with brake)	8.2	8.4	8.9	9.2	17.5	22.5	10.0	10.8	22.5
Max. Radial Load (N)	490	490	490	490	1176	1470	490	490	1470
Max. Axial Load (N)	98	98	98	98	490	490	98	98	490
Max. Power Rating (kW/s) (with brake)	6.4	24.9	43.1	59.7	24.1	35.9	19.78	32.66	63.9
Rotor Inertia ( $\times 10^{-4}$ kg.m <sup>2</sup> ) (with brake)	8.94	9.14	11.90	15.88	37.86	57.06	14.8	21.3	57.06
Mechanical Constant (ms) (with brake)	2.07	1.64	1.19	1.05	1.77	1.10	2.65	1.73	1.33
Brake Holding Torque [Nt-m (min)] <sup>*2</sup>	10.0	10.0	10.0	10.0	25.0	25.0	10.0	10.0	25.0

A

A

ECMA Series	E△13				E△18		F△13		F△18
	05	10	15	20	20	30	08	13	30
Brake Power Consumption (at 20°C) [W]	19.0	19.0	19.0	19.0	20.4	20.4	19.0	19.0	20.4
Brake Release Time [ms (Max)]	10	10	10	10	10	10	10	10	10
Brake Pull-in Time [ms (Max)]	70	70	70	70	70	70	70	70	70
Vibration Grade (μm)	15								
Operating Temperature (°C)	0 ~ 40								
Storage Temperature (°C)	-10 ~ 80								
Operating Humidity	20 ~ 90%RH (non-condensing)								
Storage Humidity	20 ~ 90%RH (non-condensing)								
Vibration Capacity	2.5G								
IP Rating	IP65 (when waterproof connectors are used, or when an oil seal is used to be fitted to the rotating shaft (an oil seal model is used))								
Approvals									

## Note:

- \*1 The rated torque is the continuous permissible torque between 0~40°C operating temperature when attaching with the following heat sink dimension:  
 ECMA-\_\_ 04 / 06 / 08: 250 mm x 250 mm x 6 mm  
 ECMA-\_\_ 10: 300 mm x 300 mm x 12 mm  
 ECMA-\_\_ 13: 400 mm x 400 mm x 20 mm  
 ECMA-\_\_ 18: 550 mm x 550 mm x 30 mm  
 Material: Aluminum – F40, F60, F80, F100, F130, F180
- \*2 The built-in brake of the servo motor is for remaining the item in stop status. Do not use it to decelerate or as the dynamic brake.
- \*3 For servo motor with magnetic encoder, please refer to the standard specifications of servo motors.
- \*4 The box (△) in the column stands for encoder type, please refer to Chapter 1 for detailed description.

## Medium/High Inertia Series

ECMA Series	G△13		
	03	06	09
Rated Power (kW)	0.3	0.6	0.9
Rated Torque (N-m) <sup>*1</sup>	2.86	5.73	8.59
Max. Torque (N-m)	8.59	17.19	21.48
Rated Speed (r/min)	1000		
Max. Speed (r/min)	2000		
Rated Current (A)	2.5	4.8	7.5
Max. Instantaneous Current (A)	7.50	14.4	22.5
Max. Power Rating (kW/s)	10.0	39.0	66.0
Rotor Inertia (× 10 <sup>-4</sup> kg.m <sup>2</sup> )	8.17	8.41	11.18
Mechanical Constant (ms)	1.84	1.40	1.07
Torque Constant-KT (N-m/A)	1.15	1.19	1.15
Voltage Constant-KE (mV / (r/min))	42.5	43.8	41.6
Armature Resistance (Ohm)	1.06	0.82	0.43
Armature Inductance (mH)	14.29	11.12	6.97
Electric Constant (ms)	13.55	13.55	16.06
Insulation Class	Class A (UL), Class B (CE)		
Insulation Resistance	>100 MΩ, DC 500 V		
Insulation Strength	AC 1500 V, 60 sec		
Weight (kg) (without brake)	6.8	7.0	7.5
Weight (kg) (with brake)	8.2	8.4	8.9
Max. Radial Load (N)	490	490	490
Max. Axial Load (N)	98	98	98
Max. Power Rating (kW/s)(with brake)	9.2	35.9	62.1
Rotor Inertia (× 10 <sup>-4</sup> kg.m <sup>2</sup> ) (with brake)	8.94	9.14	11.9
Mechanical Constant (ms) (with brake)	2.0	1.51	1.13
Brake Holding Torque [Nt-m (min)] <sup>*2</sup>	10.0	10.0	10.0
Brake Power Consumption (at 20°C)[W]	19.0	19.0	19.0
Brake Release Tim [ms (Max)]	10	10	10
Brake Pull-in Time [ms (Max)]	70	70	70
Vibration Grade (μm)	15		
Operating Temperature (°C)	0°C ~ 40°C		
Storage Temperature (°C)	-10°C ~ 80°C		

A

A

ECMA Series	G△13		
	03	06	09
Operating Humidity	20 ~ 90%RH (non-condensing)		
Storage Humidity	20 ~ 90%RH (non-condensing)		
Vibration Capacity	2.5 G		
IP Rating	IP65 (when waterproof connectors are used, or when an oil seal is used to be fitted to the rotating shaft (an oil seal model is used))		
Approvals			

Note:

- \*1 The rated torque is the continuous permissible torque between 0~40°C operating temperature when attaching with the following heat sink dimension:  
 ECMA-\_\_ 04 / 06 / 08: 250 mm x 250 mm x 6 mm  
 ECMA-\_\_ 10: 300 mm x 300 mm x 12 mm  
 ECMA-\_\_ 13: 400 mm x 400 mm x 20 mm  
 ECMA-\_\_ 18: 550 mm x 550 mm x 30 mm  
 Material type: Aluminum – F40, F60, F80, F100, F130, F180
- \*2 The built-in brake of the servo motor is for remaining the item in stop status. Do not use it to decelerate or as the dynamic brake.
- \*3 For servo motor with magnetic encoder, please refer to the standard specifications of servo motors.
- \*4 The box (△) in the column stands for encoder type, please refer to Chapter 1 for detailed description.

## High Inertia Series

ECMA Series	C△06	C△08
	04□H	07□H
Rated Power (kW)	0.4	0.75
Rated Torque (N-m) <sup>*1</sup>	1.27	2.39
Max. Torque (N-m)	3.82	7.16
Rated Speed (r/min)	3000	3000
Max. Speed (r/min)	5000	5000
Rated Current (A)	2.6	5.1
Max. Instantaneous Current (A)	7.8	15.3
Max. Power Rating (kW/s)	21.7	19.63
Rotor Inertia ( $\times 10^{-4}$ kg.m <sup>2</sup> )	0.743	2.91
Mechanical Constant (ms)	1.42	1.6
Torque Constant-KT (N-m/A)	0.49	0.47
Voltage Constant-KE (mV / (r/min))	17.4	17.2
Armature Resistance (Ohm)	1.55	0.42
Armature Inductance (mH)	6.71	3.53
Electric Constant (ms)	4.3	8.36
Insulation Class	Class A (UL), Class B (CE)	
Insulation Resistance	>100 MΩ, DC 500 V	
Insulation Strength	1.8k Vac, 1 sec	
Weight (kg) (without brake)	1.8	3.4
Weight (kg) (with brake)	2.2	3.9
Max. Radial Load (N)	196	245
Max. Axial Load (N)	68	98
Max. Power Rating (kW/s) (with brake)	21.48	19.3
Rotor Inertia ( $\times 10^{-4}$ kg.m <sup>2</sup> ) (with brake)	0.751	2.96
Mechanical Constant (ms) (with brake)	1.43	1.62
Brake Holding Torque [Nt-m (min)] <sup>*2</sup>	1.3	2.5
Brake Power Consumption (at 20°C) [W]	6.5	8.2
Brake Release Time [ms (Max)]	10	10
Brake Pull-in Time [ms (Max)]	70	70
Vibration Grade (μm)	15	
Operating Temperature (°C)	0°C ~ 40°C	
Storage Temperature (°C)	-10°C ~ 80°C	

A

A

ECMA Series	C△06	C△08
	04□H	07□H
Operating Humidity	20 ~ 90%RH (non-condensing)	
Storage Humidity	20 ~ 90%RH (non-condensing)	
Vibration Capacity	2.5 G	
IP Rating	IP65 (when waterproof connectors are used, or when an oil seal is used to be fitted to the rotating shaft (an oil seal model is used))	
Approvals		

Note:

- \*1 The rated torque is the continuous permissible torque between 0~40°C operating temperature when attaching with the following heat sink dimension:  
 ECMA-\_\_ 04 / 06 / 08: 250 mm x 250 mm x 6 mm  
 ECMA-\_\_ 10: 300 mm x 300 mm x 12 mm  
 ECMA-\_\_ 13: 400 mm x 400 mm x 20 mm  
 ECMA-\_\_ 18: 550 mm x 550 mm x 30 mm  
 Material type: Aluminum – F40, F60, F80, F100, F130, F180
- \*2 The built-in brake of the servo motor is for remaining the item in stop status. Do not use it to decelerate or as the dynamic brake.
- \*3 For servo motor with magnetic encoder, please refer to the standard specifications of servo motors.
- \*4 The box (△) in the column stands for encoder type, please refer to Chapter 1 for detailed description.

### Torque Features (T-N Curves)

A

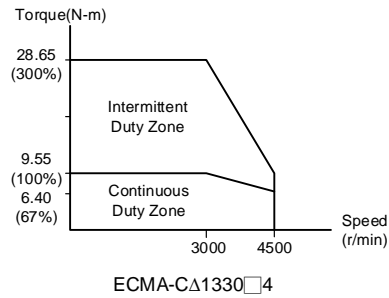
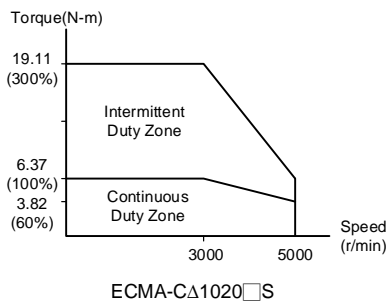
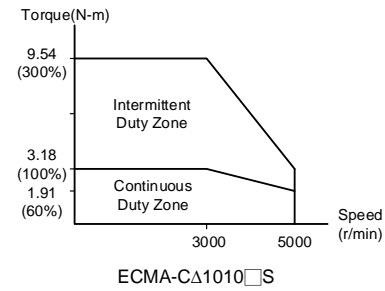
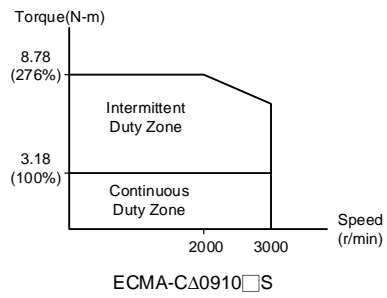
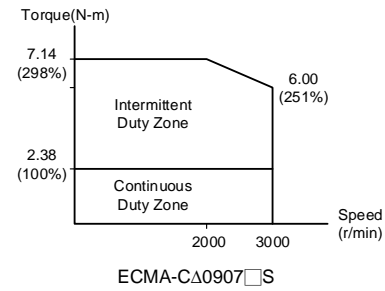
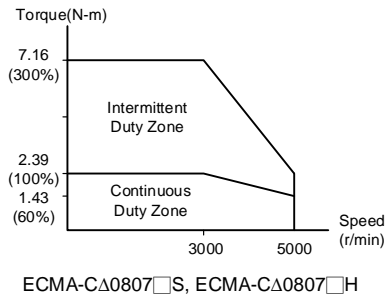
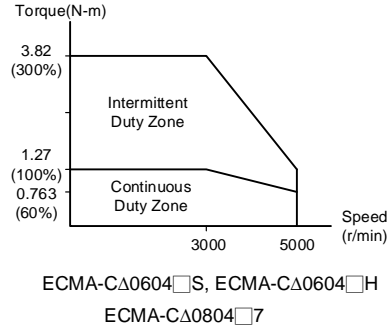
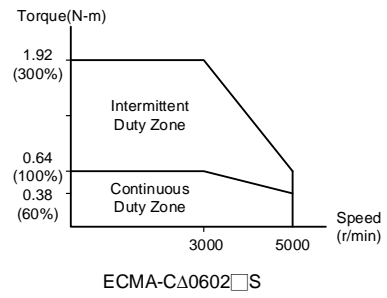
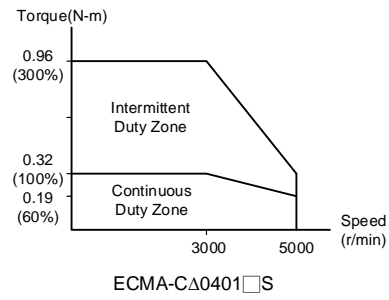
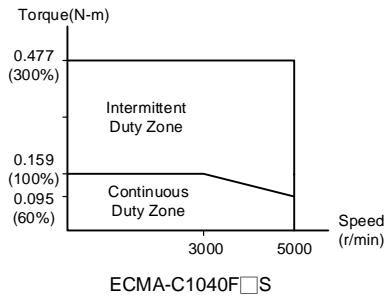

A

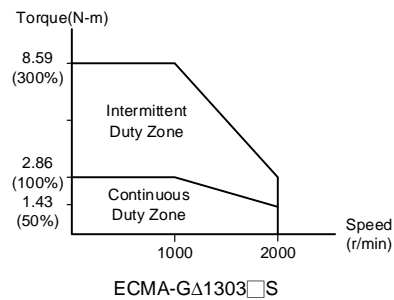
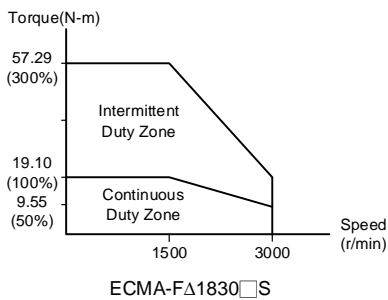
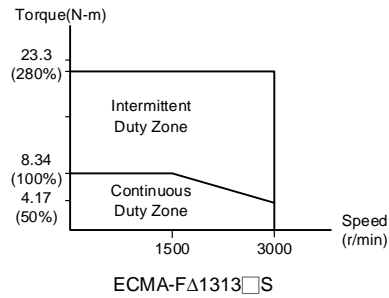
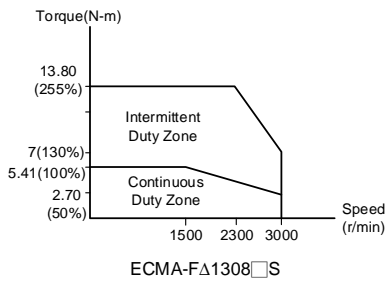
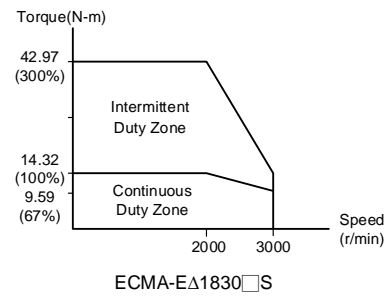
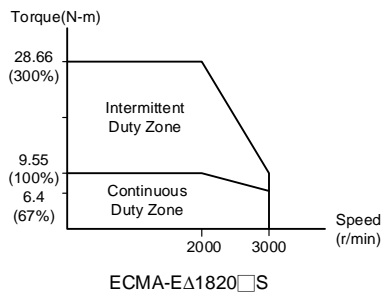
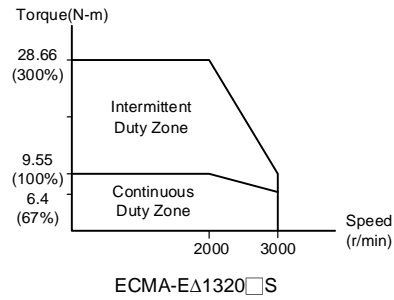
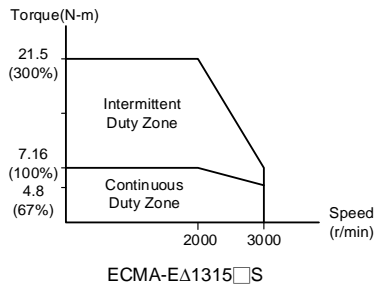
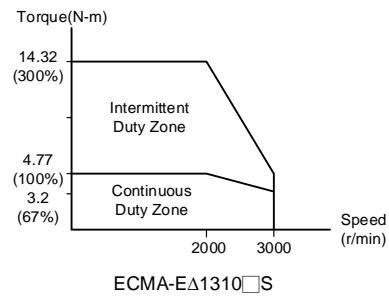
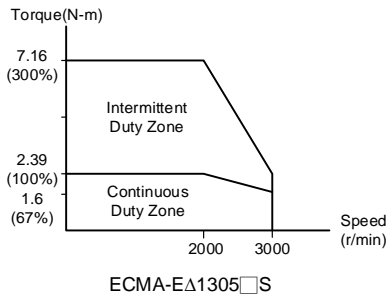

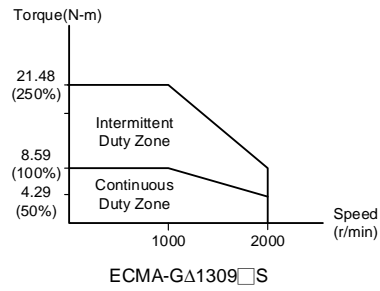
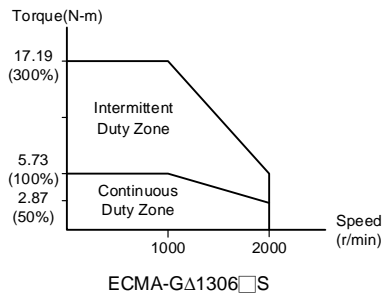

A

## Overload Features

### Definition of Overload Protection

The overload protection is to prevent the motor from overheating.

### Causes of Overload

- 1) The motor operates over the rated torque and the operation time is too long.
- 2) The inertia ratio is set to be too big and frequently accelerate/decelerate.
- 3) Connection error between power cable and encoder wiring.
- 4) Servo gain setting is in error which causes resonance of the motor.
- 5) The motor with brake operates without releasing the brake.

### Graph of Load and Operating Time

#### Low Inertia Series (ECMA C, CM Series)

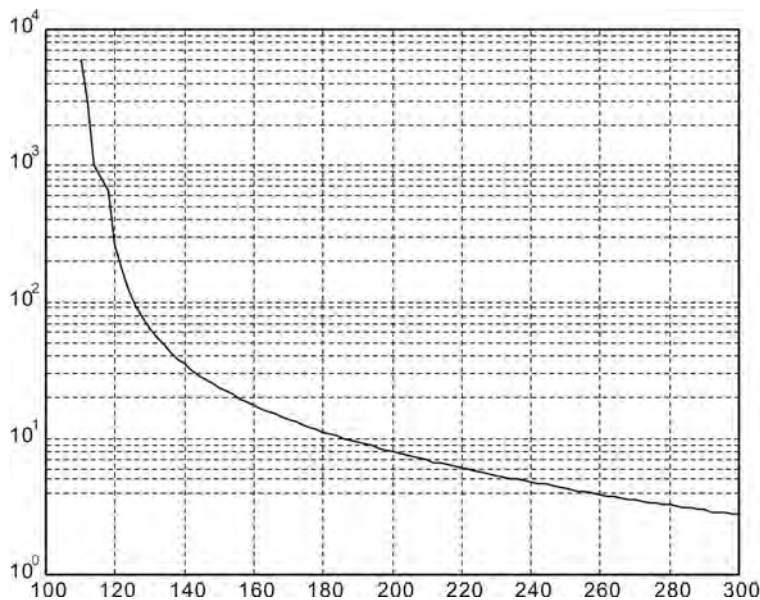

Load	Operating Time
120%	263.8s
140%	35.2s
160%	17.6s
180%	11.2s
200%	8s
220%	6.1s
240%	4.8s
260%	3.9s
280%	3.3s
300%	2.8s

A

**Medium and Medium-High Inertia Series (ECMA E, F Series)**

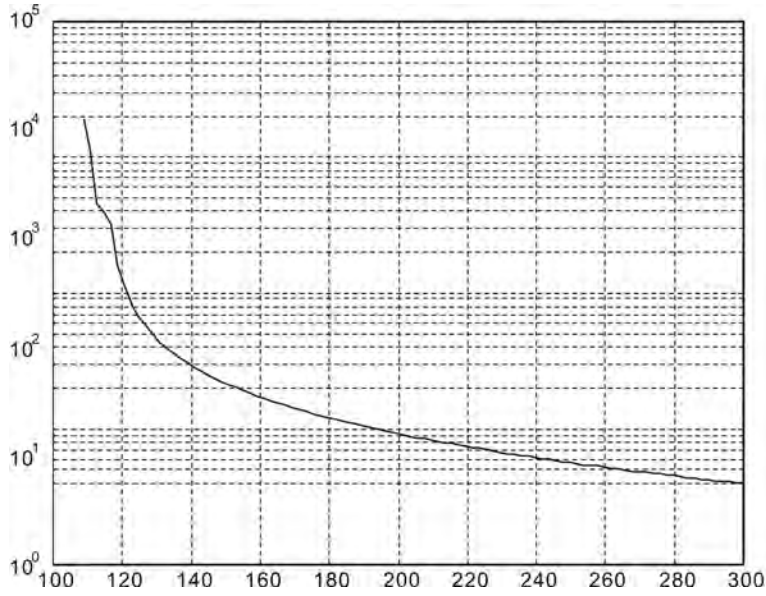

Load	Operating Time
120%	527.6s
140%	70.4s
160%	35.2s
180%	22.4s
200%	16s
220%	12.2s
240%	9.6s
260%	7.8s
280%	6.6s
300%	5.6s

**High Inertia Series (ECMA G, GM Series)**

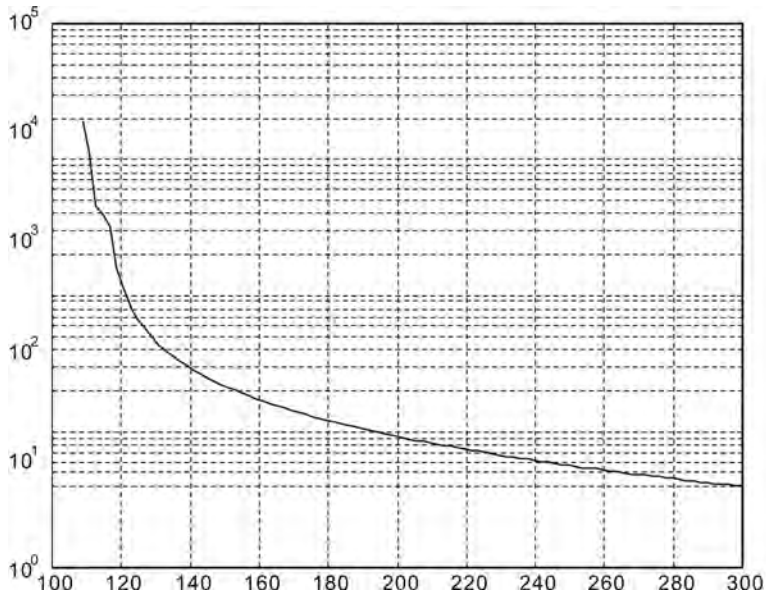

Load	Operating Time
120%	527.6s
140%	70.4s
160%	35.2s
180%	22.4s
200%	16s
220%	12.2s
240%	9.6s
260%	7.8s
280%	6.6s
300%	5.6s

### Dimensions of Servo Drive

ASD-B2-0121-F; ASD-B2-0221-F; ASD-B2-0421-F (100 W ~ 400 W)

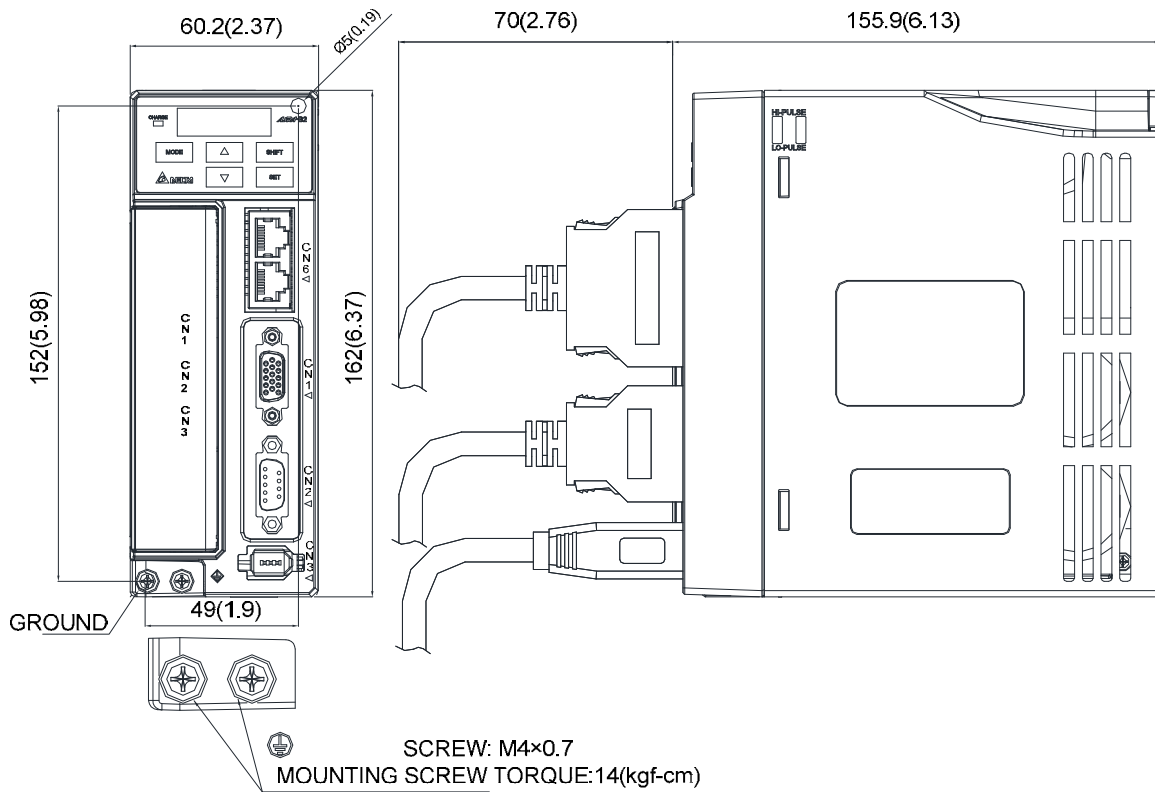

A

Weight	1.07 (2.36)
--------	-------------

Note:

1. Dimensions are in millimeters (inches); Weights are in kilograms (kg) and (pounds (lbs)).
2. Dimensions and weights of the servo drive may be changed without prior notice.

**ASD-B2-0721-F (750 W)**

A

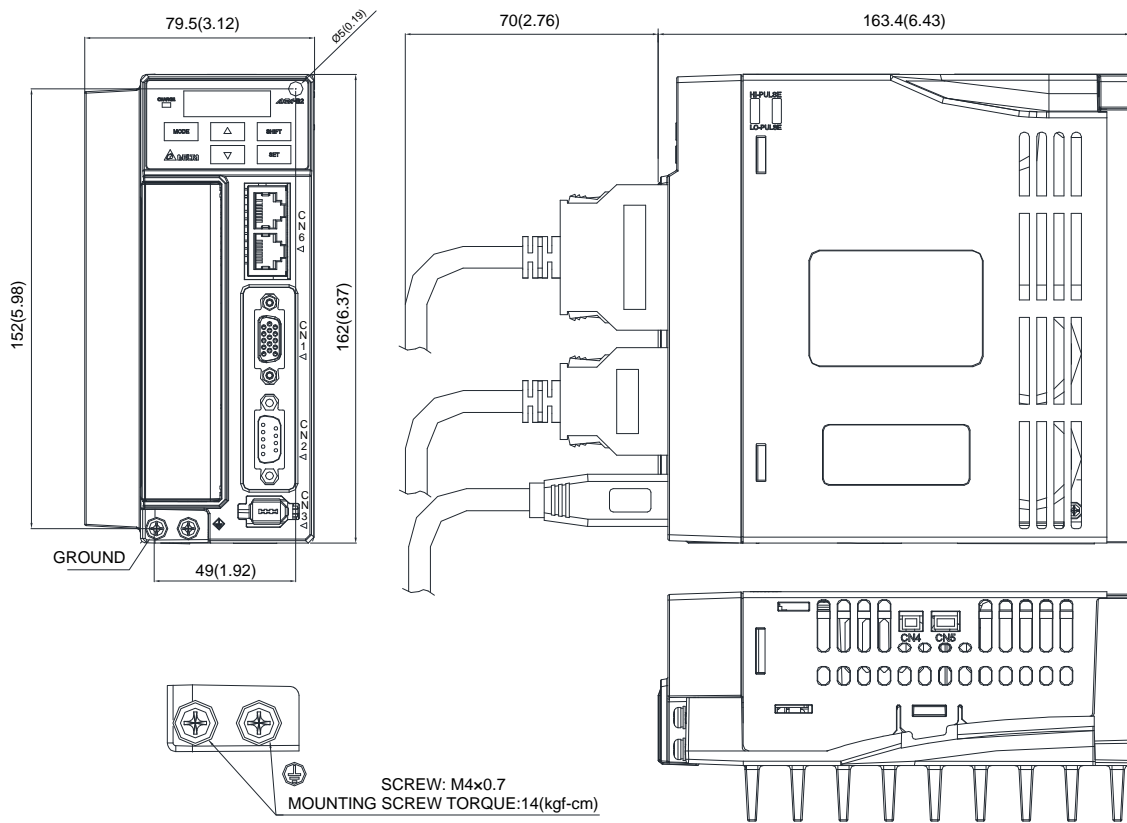

Weight	1.54 (3.40)
--------	-------------

Note:

1. Dimensions are in millimeters (inches); Weights are in kilograms (kg) and (pounds (lbs)).
2. Dimensions and weights of the servo drive may be changed without prior notice.

**ASD-B2-1021-F; ASD-B2-1521-F (1 kW ~ 1.5 kW)**

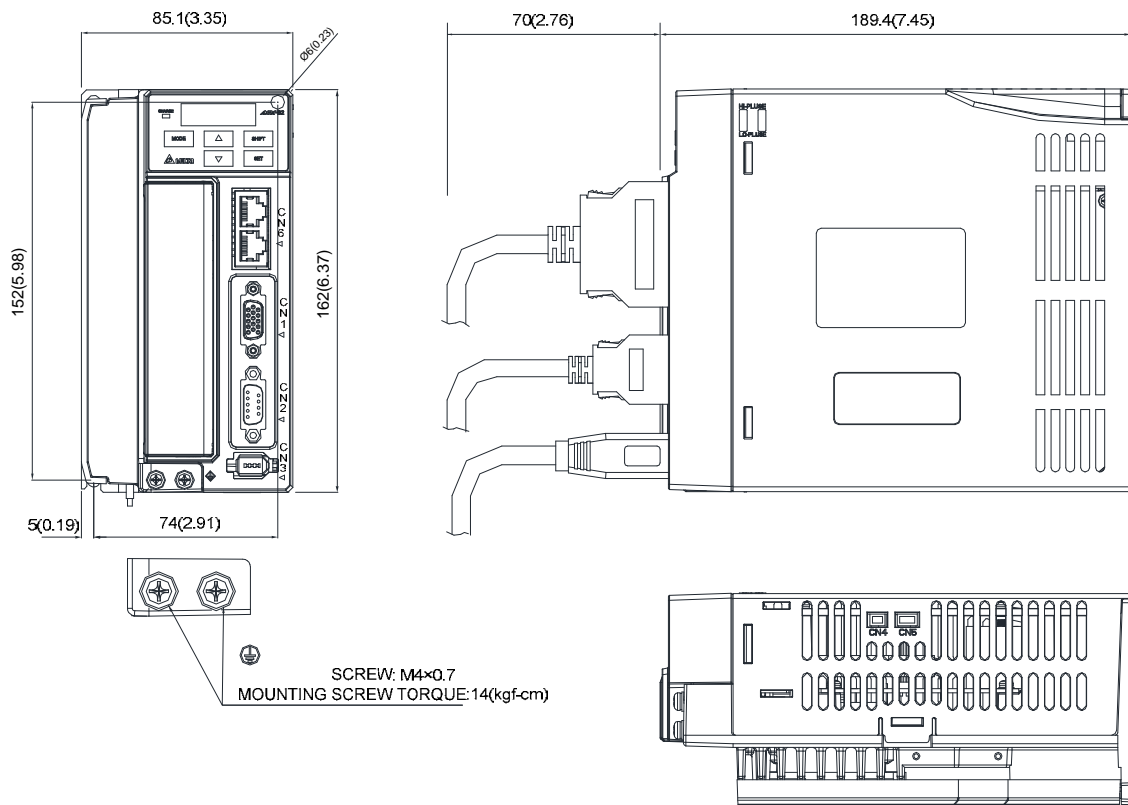

Weight	1.72 (3.79)
--------	-------------

Note:

1. Dimensions are in millimeters (inches); Weights are in kilograms (kg) and (pounds (lbs)).
2. Dimensions and weights of the servo drive may be changed without prior notice.

ASD-B2-2023-F; ASD-B2-3023-F (2 kW ~ 3 kW)

A

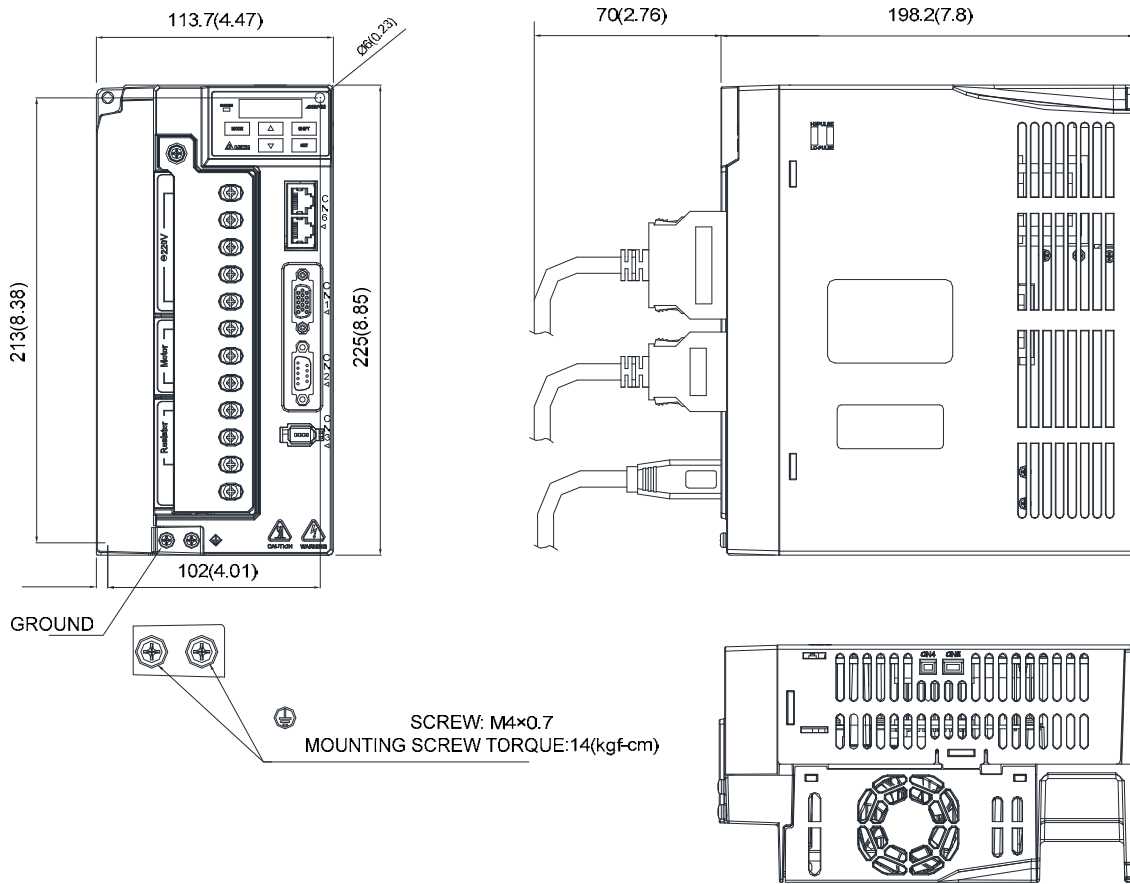

Weight	2.67 (5.88)
--------	-------------

Note:

1. Dimensions are in millimeters (inches); Weights are in kilograms (kg) and (pounds (lbs)).
2. Dimensions and weights of the servo drive may be changed without prior notice.

## Dimensions of Servo Motor

### Motor Frame Size: 86 mm and below

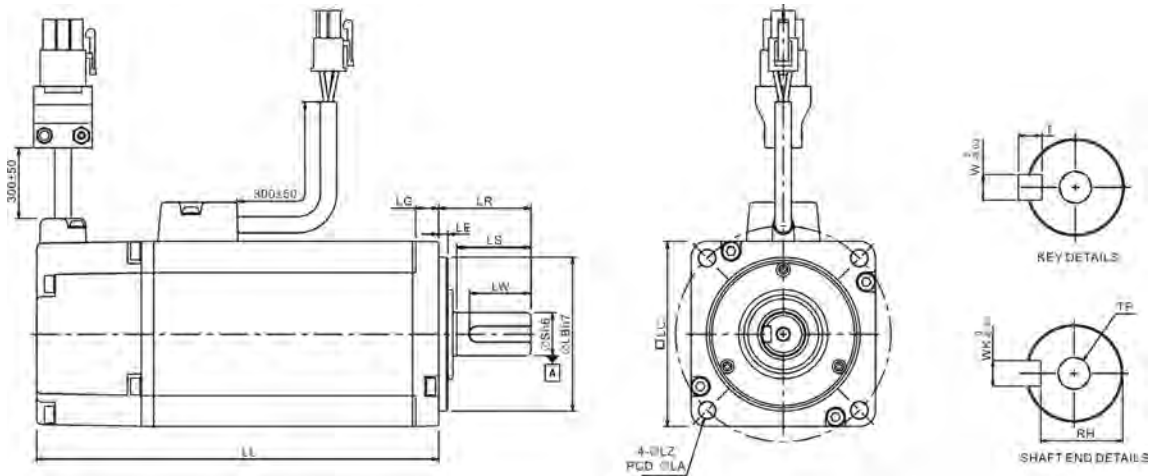

A

Model	C1040F□S	CΔ0401□S	CΔ0602□S	CΔ0604□S	CΔ0604□H
LC	40	40	60	60	60
LZ	4.5	4.5	5.5	5.5	5.5
LA	46	46	70	70	70
S	8 <sup>(+0/-0.009)</sup>	8 <sup>(+0/-0.009)</sup>	14 <sup>(+0/-0.011)</sup>	14 <sup>(+0/-0.011)</sup>	14 <sup>(+0/-0.011)</sup>
LB	30 <sup>(+0/-0.021)</sup>	30 <sup>(+0/-0.021)</sup>	50 <sup>(+0/-0.025)</sup>	50 <sup>(+0/-0.025)</sup>	50 <sup>(+0/-0.025)</sup>
LL (without brake)	79.1	100.6	105.5	130.7	145.8
LL (with brake)	--	136.6	141.6	166.8	176.37
LS	20	20	27	27	27
LR	25	25	30	30	30
LE	2.5	2.5	3	3	3
LG	5	5	7.5	7.5	7.5
LW	16	16	20	20	20
RH	6.2	6.2	11	11	11
WK	3	3	5	5	5
W	3	3	5	5	5
T	3	3	5	5	5
TP	M3 Depth 8	M3 Depth 8	M4 Depth 15	M4 Depth 15	M4 Depth 15

Note:

1. Dimensions are in millimeters.
2. Dimensions and weights of the servo motor may be changed without prior notice.
3. The boxes (□) in Model stand for shaft end / brake or the number of oil seal.
4. The boxes (Δ) in Model stand for encoder type. Please refer to Chapter 1 for detailed description.
5. For motors with magnetic encoder, please refer to standard dimensions of servo motor. (Except for ECMA-CM0604PS LL: 116.2 mm)

**Motor Frame Size: 86 mm and models below**

A

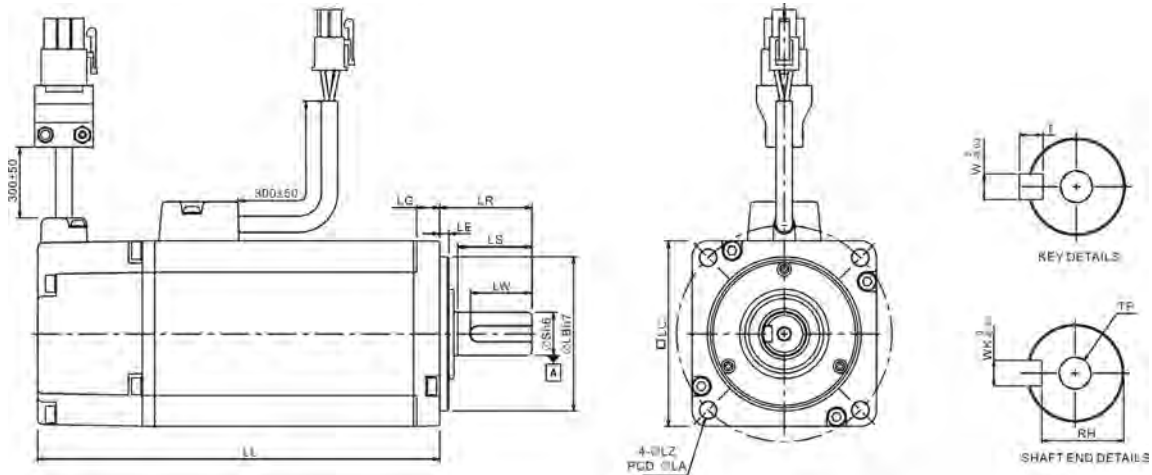

Model	C△0804□7	C△0807□S	C△0807□H	C△0907□S	C△0910□S
LC	80	80	80	86	86
LZ	6.6	6.6	6.6	6.6	6.6
LA	90	90	90	100	100
S	14 <sup>(+0/-0.011)</sup>	19 <sup>(+0/-0.013)</sup>	19 <sup>(+0/-0.013)</sup>	16 <sup>(+0/-0.011)</sup>	16 <sup>(+0/-0.011)</sup>
LB	70 <sup>(+0/-0.030)</sup>	70 <sup>(+0/-0.030)</sup>	70 <sup>(+0/-0.030)</sup>	80 <sup>(+0/-0.030)</sup>	80 <sup>(+0/-0.030)</sup>
LL (without brake)	112.3	138.3	151.1	130.2	153.2
LL (with brake)	152.8	178	189	161.3	184.3
LS	27	32	32	30	30
LR	30	35	35	35	35
LE	3	3	3	3	3
LG	8	8	8	8	8
LW	20	25	25	20	20
RH	11	15.5	15.5	13	13
WK	5	6	6	5	5
W	5	6	6	5	5
T	5	6	6	5	5
TP	M4 Depth 15	M6 Depth 20	M6 Depth 20	M5 Depth 15	M5 Depth 15

**Note:**

1. Dimensions are in millimeters.
2. Dimensions and weights of the servo drive may be changed without prior notice.
3. The boxes (□) in model stand for shaft end / brake or the number of oil seal.
4. The boxes (△) in model stand for encoder type. Please refer to Chapter 1 for detailed description.
5. For motors with magnetic encoder, please refer to standard dimensions of servo motor. (Except for ECMA-CM0604PS LL: 116.2 mm)

Motor Frame Size: 100 ~ 130 mm

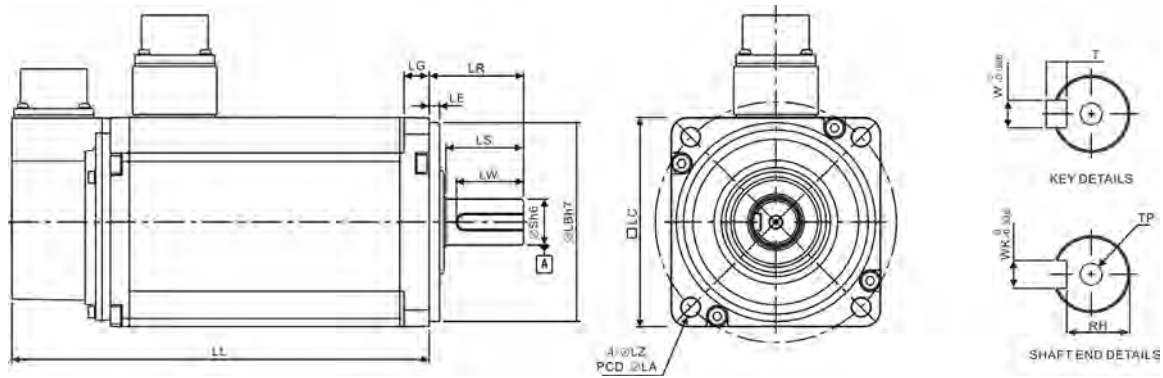

A

Model	C△1010□S	C△1020□S	C△1330□4	E△1305□S	E△1310□S	E△1315□S
LC	100	100	130	130	130	130
LZ	9	9	9	9	9	9
LA	115	115	145	145	145	145
S	22 <sup>+0</sup> <sub>-0.013</sub>	22 <sup>+0</sup> <sub>-0.013</sub>	24 <sup>+0</sup> <sub>-0.013</sub>	22 <sup>+0</sup> <sub>-0.013</sub>	22 <sup>+0</sup> <sub>-0.013</sub>	22 <sup>+0</sup> <sub>-0.013</sub>
LB	95 <sup>+0</sup> <sub>-0.035</sub>	95 <sup>+0</sup> <sub>-0.035</sub>	110 <sup>+0</sup> <sub>-0.035</sub>	110 <sup>+0</sup> <sub>-0.035</sub>	110 <sup>+0</sup> <sub>-0.035</sub>	110 <sup>+0</sup> <sub>-0.035</sub>
LL (without brake)	153.3	199	187.5	147.5	147.5	167.5
LL (with brake)	192.5	226	216.0	183.5	183.5	202
LS	37	37	47	47	47	47
LR	45	45	55	55	55	55
LE	5	5	6	6	6	6
LG	12	12	11.5	11.5	11.5	11.5
LW	32	32	36	36	36	36
RH	18	18	20	18	18	18
WK	8	8	8	8	8	8
W	8	8	8	8	8	8
T	7	7	7	7	7	7
TP	M6 Depth 20	M6 Depth 20	M6 Depth 20	M6 Depth 20	M6 Depth 20	M6 Depth 20

Note:

1. Dimensions are in millimeters.
2. Dimensions and weights of the servo drive may be changed without prior notice.
3. The boxes (□) in model stand for shaft end / brake or the number of oil seal.
4. The boxes (△) in model stand for encoder type. Please refer to Chapter 1 for detailed description.
5. For motors with magnetic encoder, please refer to standard dimensions of servo motor.

Motor Frame Size: 100 ~ 130 mm

A

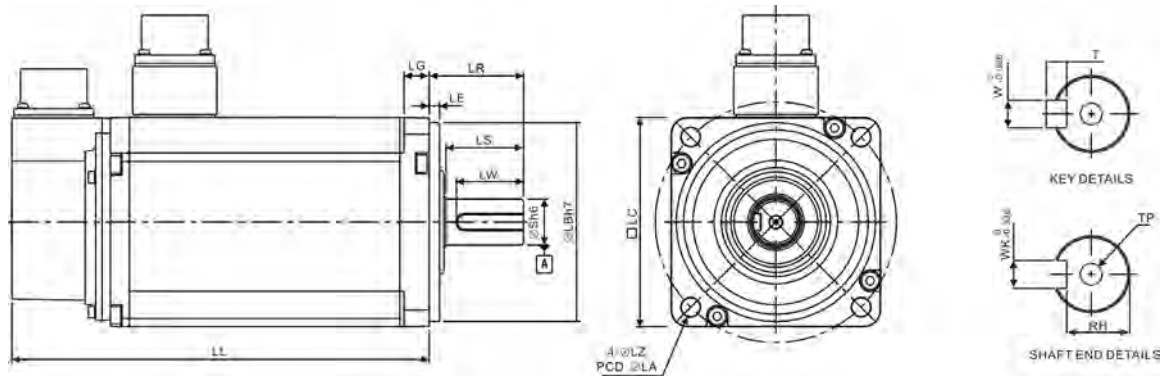

Model	E△1320□S	F△1308□S	F△1313□S	G△1303□S	G△1306□S	G△1309□S
LC	130	130	130	130	130	130
LZ	9	9	9	9	9	9
LA	145	145	145	145	145	145
S	22 <sup>(+0/-0.013)</sup>	22 <sup>(+0/-0.013)</sup>	22 <sup>(+0/-0.013)</sup>	22 <sup>(+0/-0.013)</sup>	22 <sup>(+0/-0.013)</sup>	22 <sup>(+0/-0.013)</sup>
LB	110 <sup>(+0/-0.035)</sup>	110 <sup>(+0/-0.035)</sup>	110 <sup>(+0/-0.035)</sup>	110 <sup>(+0/-0.035)</sup>	110 <sup>(+0/-0.035)</sup>	110 <sup>(+0/-0.035)</sup>
LL (without brake)	187.5	152.5	187.5	147.5	147.5	163.5
LL (with brake)	216	181	216	183.5	183.5	198
LS	47	47	47	47	47	47
LR	55	55	55	55	55	55
LE	6	6	6	6	6	6
LG	11.5	11.5	11.5	11.5	11.5	11.5
LW	36	36	36	36	36	36
RH	18	18	18	18	18	18
WK	8	8	8	8	8	8
W	8	8	8	8	8	8
T	7	7	7	7	7	7
TP	M6 Depth 20	M6 Depth 20	M6 Depth 20	M6 Depth 20	M6 Depth 20	M6 Depth 20

Note:

1. Dimensions are in millimeters.
2. Dimensions and weights of the servo drive may be changed without prior notice.
3. The boxes (□) in model stand for shaft end / brake or the number of oil seal.
4. The boxes (△) in model stand for encoder type. Please refer to Chapter 1 for detailed description.

### Motor Frame Size: 180 mm

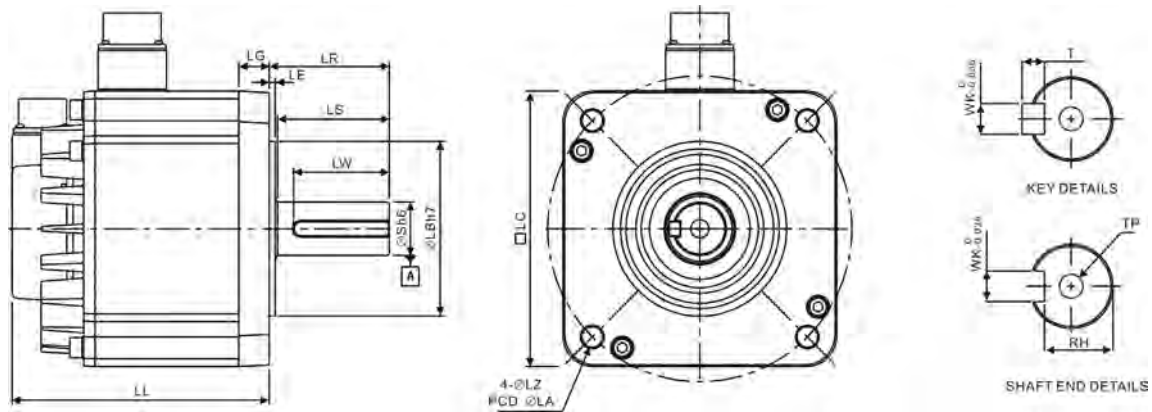

A

Model	E△1820□ S	E△1830□ S	F△1830□ S
LC	180	180	180
LZ	13.5	13.5	13.5
LA	200	200	200
S	$35^{+0}_{-0.016}$	$35^{+0}_{-0.016}$	$35^{+0}_{-0.016}$
LB	$114.3^{+0}_{-0.035}$	$114.3^{+0}_{-0.035}$	$114.3^{+0}_{-0.035}$
LL (without brake)	169	202.1	202.1
LL (with brake)	203.1	235.3	235.3
LS	73	73	73
LR	79	79	79
LE	4	4	4
LG	20	20	20
LW	63	63	63
RH	30	30	30
WK	10	10	10
W	10	10	10
T	8	8	8
TP	M12 Depth 25	M12 Depth 25	M12 Depth 25

Note:

1. Dimensions are in millimeters.
2. Dimensions and weights of the servo drive may be changed without prior notice.
3. The boxes (□) in model stand for shaft end / brake or the number of oil seal.
4. The boxes (△) in model stand for encoder type. Please refer to Chapter 1 for detailed description.

(This page is intentionally left blank.)

A

# B

## Accessories Appendix

---

Power Connector.....	B-2
Power Cable.....	B-3
Encoder Connector.....	B-5
Encoder Cable.....	B-5
Encoder Cable (Absolute Type).....	B-6
Battery Box Cable AW.....	B-7
Battery Box Cable IW.....	B-7
Battery Box (Absolute Type).....	B-8
I / O Connector Terminal.....	B-9
CN1 Convenient Connector.....	B-9
PC Connection Cable.....	B-10
Terminal Block Module.....	B-10
Optional Accessories.....	B-11

## Power Connector

Delta Part Number: ASDBCAPW0000

B

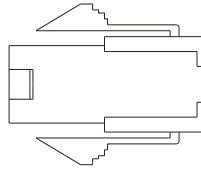

Delta Part Number: ASDBCAPW0100

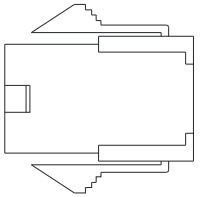

Delta Part Number: ASD-CAPW1000

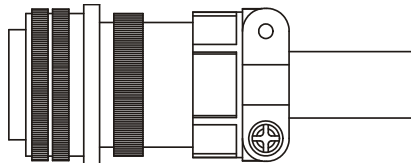

3106A-20-18S

Delta Part Number: ASD-CAPW2000

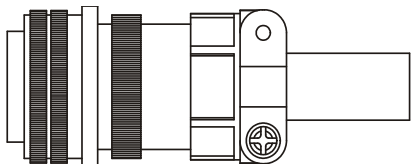

3106A-24-11S

### Power Cable

Delta Part Number: ASDBCAPW0203 / 0205

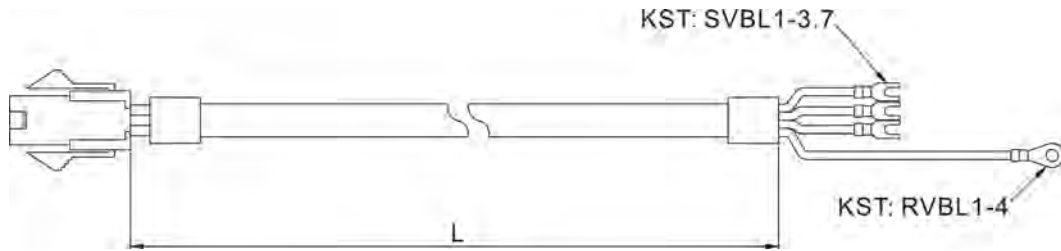

Title	Part No.	L	
		mm	inch
1	ASDBCAPW0203	3000 ± 50	118 ± 2
2	ASDBCAPW0205	5000 ± 50	197 ± 2

Delta Part Number: ASDBCAPW0303 / 0305

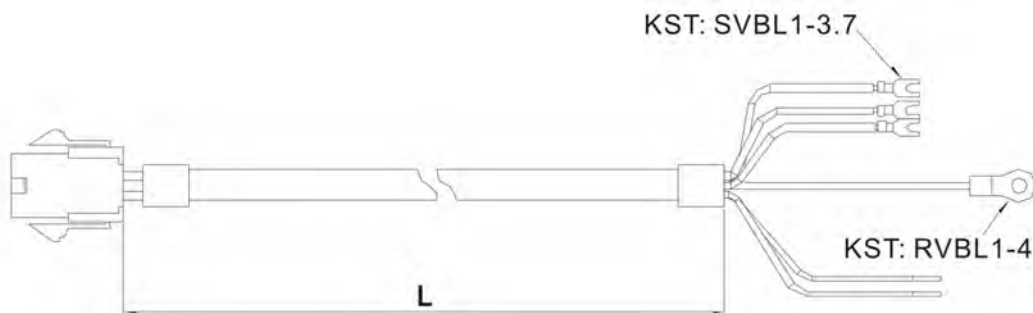

Title	Part No.	L	
		mm	inch
1	ASDBCAPW0303	3000 ± 50	118 ± 2
2	ASDBCAPW0305	5000 ± 50	197 ± 2

Delta Part Number: ASDBCAPW1203 / 1205

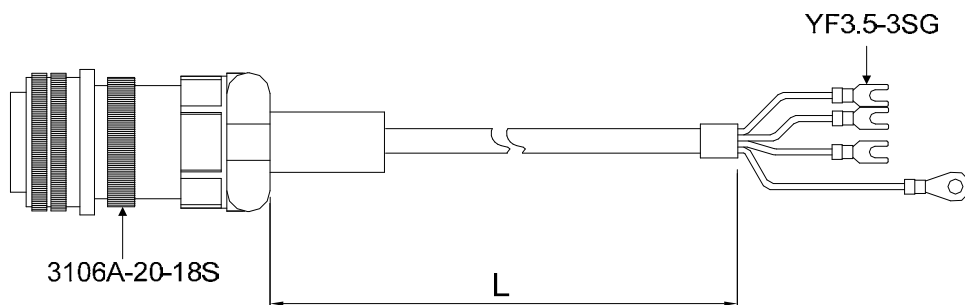

Title	Part No.	Straight	L	
			mm	inch
1	ASDBCAPW1203	3106A-20-18S	3000 ± 50	118 ± 2
2	ASDBCAPW1205	3106A-20-18S	5000 ± 50	197 ± 2

B

Delta Part Number: ASDBCAPW1303 / 1305

B

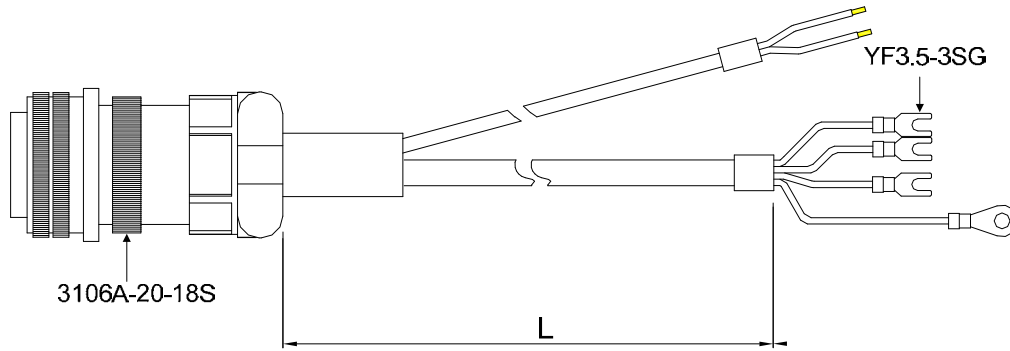

Title	Part No.	Straight	L	
			mm	inch
1	ASDBCAPW1303	3106A-20-18S	3000 ± 50	118 ± 2
2	ASDBCAPW1305	3106A-20-18S	5000 ± 50	197 ± 2

Delta Part Number: ASD-CAPW2203 / 2205

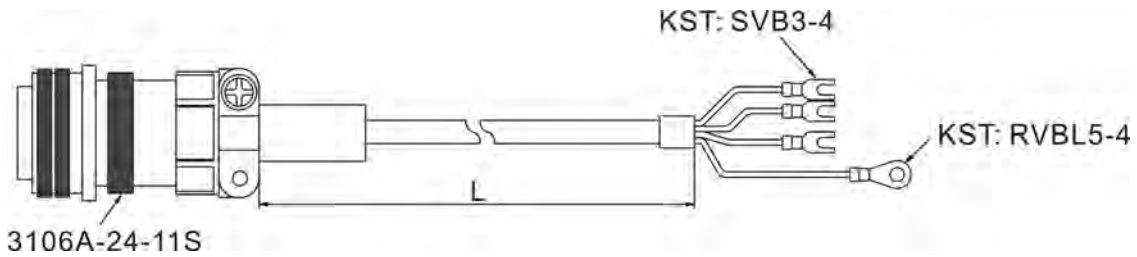

Title	Part No.	Straight	L	
			mm	inch
1	ASD-CAPW2203	3106A-24-11S	3000 ± 50	118 ± 2
2	ASD-CAPW2205	3106A-24-11S	5000 ± 50	197 ± 2

Delta Part Number: ASD-CAPW2303 / 2305

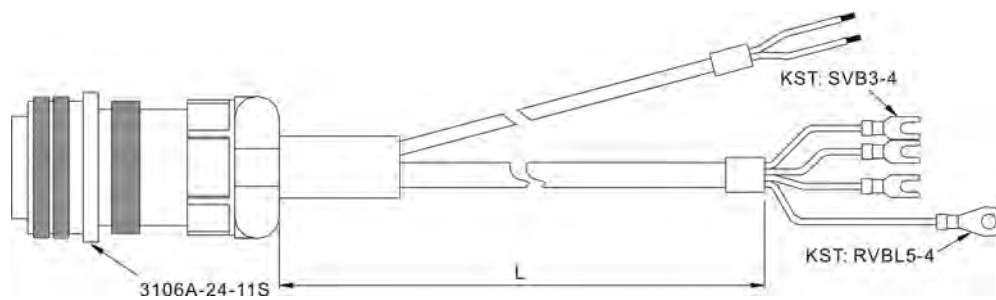

Title	Part No.	Straight	L	
			mm	inch
1	ASD-CAPW2303	3106A-24-11S	3000 ± 50	118 ± 2
2	ASD-CAPW2305	3106A-24-11S	5000 ± 50	197 ± 2

### Encoder Connector

Delta Part Number: ASDBCAEN0000

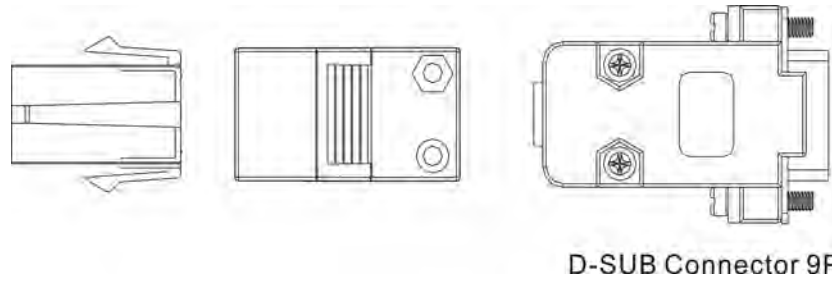

D-SUB Connector 9P

Delta Part Number: ASDBCAEN1000

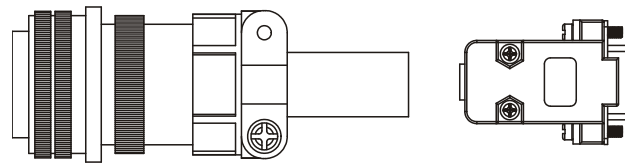

3106A-20-29S

D-SUB Connector 9P

### Encoder Cable

Delta part number: ASDBCAEN0003 / 0005

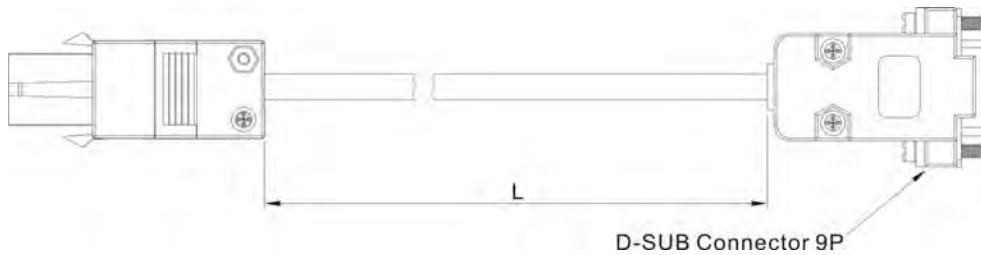

D-SUB Connector 9P

Title	Part No.	L	
		mm	inch
1	ASDBCAEN0003	3000 ± 50	118 ± 2
2	ASDBCAEN0005	5000 ± 50	197 ± 2

Delta Part Number: ASDBCAEN1003 / 1005

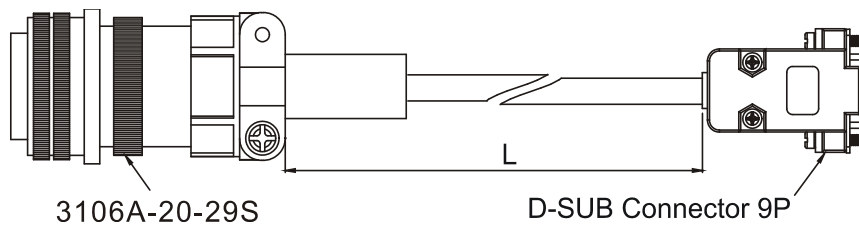

3106A-20-29S

D-SUB Connector 9P

Title	Part No.	Straight	L	
			mm	inch
1	ASDBCAEN1003	3106A-20-29S	3000 ± 50	118 ± 2
2	ASDBCAEN1005	3106A-20-29S	5000 ± 50	197 ± 2

### Encoder Cable (Absolute Type)

Delta Part Number: ASD-B2EB0003, ASD-B2EB0005

B

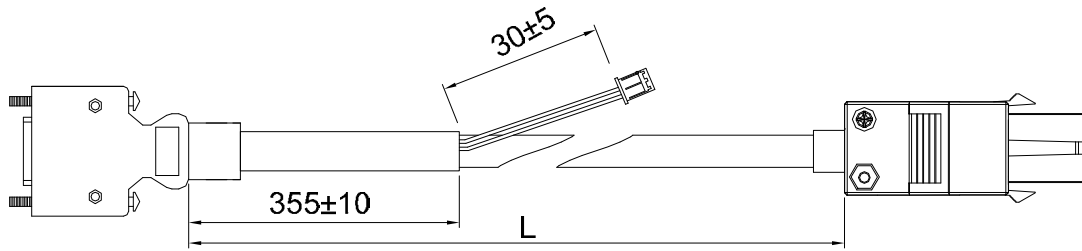

Title	Model Name	L	
		mm	inch
1	ASD-B2EB0003	3000 ± 100	118 ± 4
2	ASD-B2EB0005	5000 ± 100	197 ± 4

Delta Part Number: ASD-B2EB1003, ASD-B2EB1005

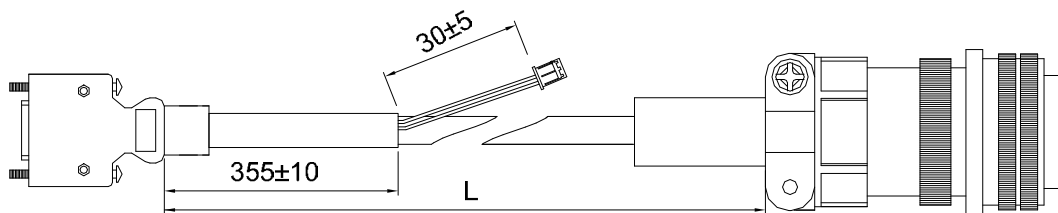

Title	Model Name	L	
		mm	inch
1	ASD-B2EB1003	3000 ± 100	118 ± 4
2	ASD-B2EB1005	5000 ± 100	197 ± 4

### Battery Box Cable AW

Delta Part Number: 3864573700

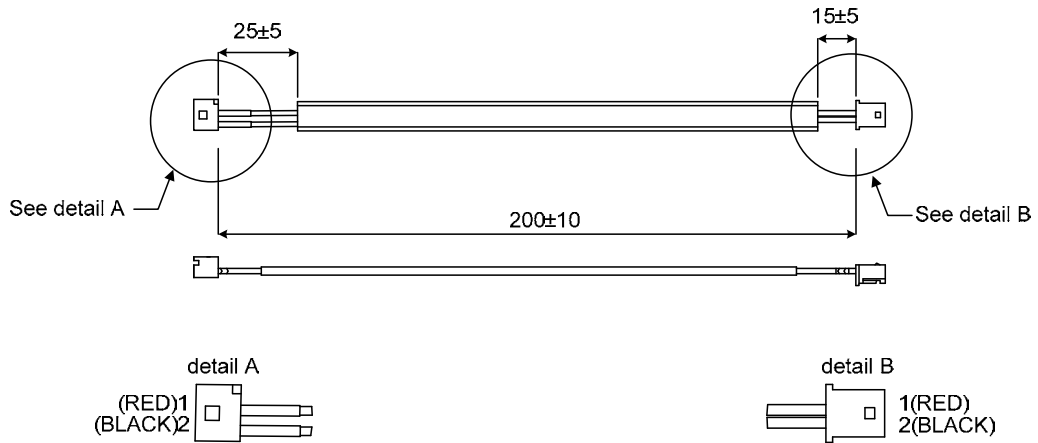

B

### Battery Box Cable IW

Delta part number: 3864811900

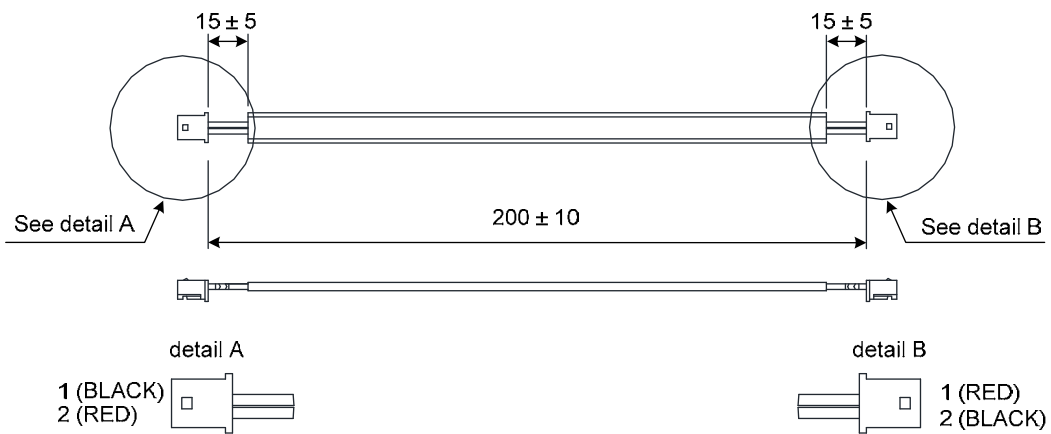

### Battery Box (Absolute Type)

Single Battery Box  
Delta Part Number: ASD-MDBT0100

B

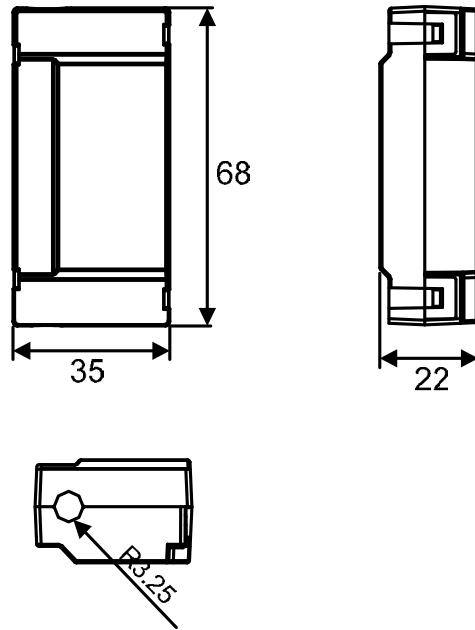

Unit: mm

Dual Battery Box  
Delta Part Number: ASD-MDBT0200

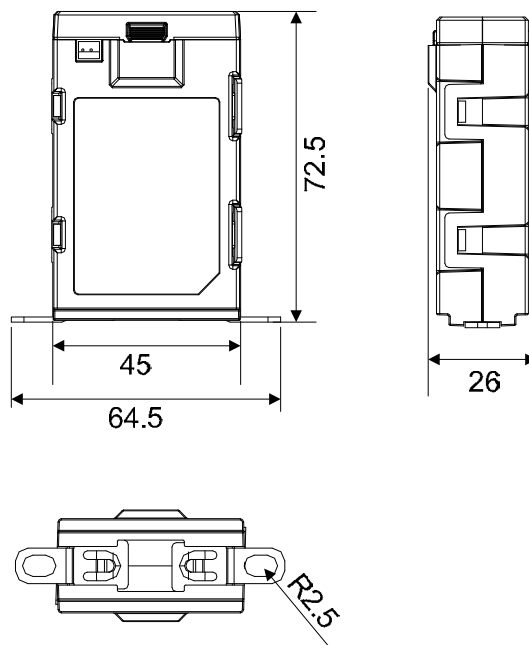

Unit: mm

## I / O Connector Terminal

Delta Part Number: ASDBCNDS0044

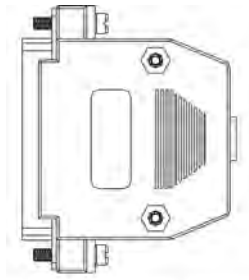

D-SUB 44 PIN PLUG

Delta Part Number: ASD-CNDS0015

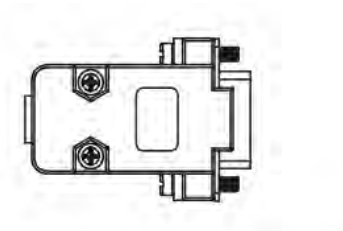

D-SUB 15 PIN PLUG

## CN1 Convenient Connector

Delta Part Number: ASD-IF-DS1516

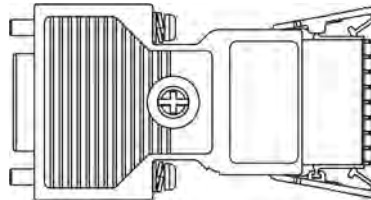

B

### PC Connection Cable

Delta Part Number: ASD-CNUS0A08

B

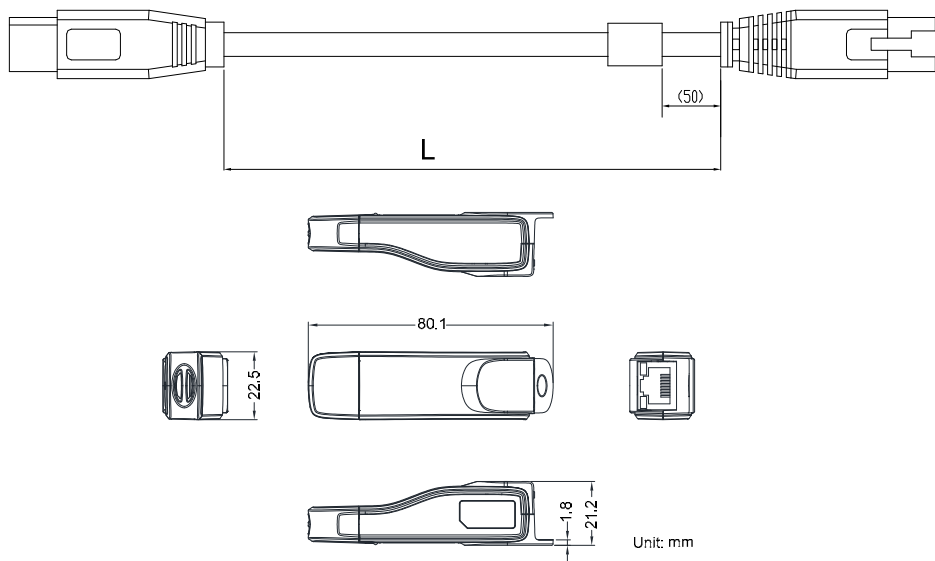

Title		Part No.: ASD-CNUS0A08	
cable	L	3000 ± 100 mm	
		118 ± 4 inch	
connector	RJ connector	RJ-45	
	USB connector	A-type (USB V2.0)	

### Terminal Block Module

Delta Part Number: ASD-MDDS4444

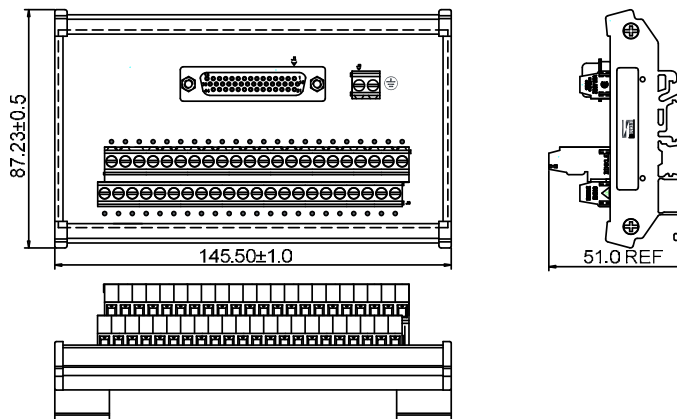

## Optional Accessories

### 100 W Servo Drive with 50 W Low-inertia Motor

Servo Drive	ASD-B2-0121-F
Low-inertia Motor	ECMA-C1040F□S
Motor Power Cable (without brake)	ASDBCAPW020X
Power Connector (without brake)	ASDBCAPW0000
Motor Power Cable (with brake)	ASDBCAPW030X
Power Connector (with brake)	ASDBCAPW0100
Incremental Encoder Cable	ASDBCAEN000X
Absolute Encoder Cable	ASD-B2EB000X
Encoder Connector	ASDBCAEN0000

(X = 3 indicates that the cable length is 3 m; X = 5 indicates that the cable length is 5 m)

### 100 W Servo Drive with 100 W Low-inertia Motor

Servo Drive	ASD-B2-0121-F
Low-inertia Motor	ECMA-C△0401□S
Motor Power Cable (without brake)	ASDBCAPW020X
Power Connector (without brake)	ASDBCAPW0000
Motor Power Cable (with brake)	ASDBCAPW030X
Power Connector (with brake)	ASDBCAPW0100
Incremental Encoder Cable	ASDBCAEN000X
Absolute Encoder Cable	ASD-B2EB000X
Encoder Connector	ASDBCAEN0000

(X = 3 indicates that the cable length is 3 m; X = 5 indicates that the cable length is 5 m)

### 200 W Servo Drive with 200 W Low-inertia Motor

Servo Drive	ASD-B2-0221-F
Low-inertia Motor	ECMA-C△0602□S
Motor Power Cable (without brake)	ASDBCAPW020X
Power Connector (without brake)	ASDBCAPW0000
Motor Power Cable (with brake)	ASDBCAPW030X
Power Connector (with brake)	ASDBCAPW0100
Incremental Encoder Cable	ASDBCAEN000X
Absolute Encoder Cable	ASD-B2EB000X
Encoder Connector	ASDBCAEN0000

(X = 3 indicates that the cable length is 3 m; X = 5 indicates that the cable length is 5 m)

# B

B

**400 W Servo Drive with 400 W Low-inertia Motor**

Servo Drive	ASD-B2-0421-F
Low-inertia Motor	ECMA-C△0604□S ECMA-C△0804□7
Motor Power Cable (without brake)	ASDBCAPW020X
Power Connector (without brake)	ASDBCAPW0000
Motor Power Cable (with brake)	ASDBCAPW030X
Power Connector (with brake)	ASDBCAPW0100
Incremental Encoder Cable	ASDBCAEN000X
Absolute Encoder Cable	ASD-B2EB000X
Encoder Connector	ASDBCAEN0000

(X = 3 indicates that the cable length is 3 m; X = 5 indicates that the cable length is 5 m)

**400 W Servo Drive with 400 W High-inertia Motor**

Servo Drive	ASD-B2-0421-F
High-inertia Motor	ECMA-C△0604□H
Motor Power Cable (without brake)	ASDBCAPW020X
Power Connector (without brake)	ASDBCAPW0000
Motor Power Cable (with brake)	ASDBCAPW030X
Power Connector (with brake)	ASDBCAPW0100
Incremental Encoder Cable	ASDBCAEN000X
Absolute Encoder Cable	ASD-B2EB000X
Encoder Connector	ASDBCAEN0000

(X = 3 indicates that the cable length is 3 m; X = 5 indicates that the cable length is 5 m)

**400 W Servo Drive with 500 W Medium-inertia Motor**

Servo Drive	ASD-B2-0421-F
Medium-inertia Motor	ECMA-E△1305□S
Motor Power Cable (without brake)	ASDBCAPW120X
Motor Power Cable (with brake)	ASDBCAPW130X
Power Connector	ASD-CAPW1000
Incremental Encoder Cable	ASDBCAEN100X
Absolute Encoder Cable	ASD-B2EB100X
Encoder Connector	ASDBCAEN1000

(X = 3 indicates that the cable length is 3 m; X = 5 indicates that the cable length is 5 m)

**400 W Servo Drive with 300 W High-inertia Motor**

Servo Drive	ASD-B2-0421-F
High-inertia Motor	ECMA-G△1303□S
Motor Power Cable (without brake)	ASDBCAPW120X
Motor Power Cable (with brake)	ASDBCAPW130X
Power Connector	ASD-CAPW1000
Incremental Encoder Cable	ASDBCAEN100X
Absolute Encoder Cable	ASD-B2EB100X
Encoder Connector	ASDBCAEN1000

(X = 3 indicates that the cable length is 3 m; X = 5 indicates that the cable length is 5 m)

**750 W Servo Drive with 600 W High-inertia Motor**

Servo Drive	ASD-B2-0721-F
High-inertia Motor	ECMA-G△1306□S
Motor Power Cable (without brake)	ASDBCAPW120X
Motor Power Cable (with brake)	ASDBCAPW130X
Power Connector	ASD-CAPW1000
Incremental Encoder Cable	ASDBCAEN100X
Absolute Encoder Cable	ASD-B2EB100X
Encoder Connector	ASDBCAEN1000

(X = 3 indicates that the cable length is 3 m; X = 5 indicates that the cable length is 5 m)

**750 W Servo Drive with 750 W Low-inertia Motor**

Servo Drive	ASD-B2-0721-F
Low-inertia Motor	ECMA-C△0807□S ECMA-C△0907□S
Motor Power Cable (without brake)	ASDBCAPW020X
Power Connector (without brake)	ASDBCAPW0000
Motor Power Cable (with brake)	ASDBCAPW030X
Power Connector (with brake)	ASDBCAPW0100
Incremental Encoder Cable	ASDBCAEN000X
Absolute Encoder Cable	ASD-B2EB100X
Encoder Connector	ASDBCAEN0000

(X = 3 indicates that the cable length is 3 m; X = 5 indicates that the cable length is 5 m)

B

B

**750 W Servo Drive with 750 W High-inertia Motor**

Servo Drive	ASD-B2-0721-F
High-inertia Motor	ECMA-C△0807□H
Motor Power Cable (without brake)	ASDBCAPW020X
Power Connector (without brake)	ASDBCAPW0000
Motor Power Cable (with brake)	ASDBCAPW030X
Power Connector (with brake)	ASDBCAPW0100
Incremental Encoder Cable	ASDBCAEN000X
Absolute Encoder Cable	ASD-B2EB000X
Encoder Connector	ASDBCAEN0000

(X = 3 indicates that the cable length is 3 m; X = 5 indicates that the cable length is 5 m)

**1 kW Servo Drive with 850 W Low-inertia Motor**

Servo Drive	ASD-B2-1021-F
Low-inertia Motor	ECMA-F△1308□S
Motor Power Cable (without brake)	ASDBCAPW120X
Motor Power Cable (with brake)	ASDBCAPW130X
Power Connector	ASD-CAPW1000
Incremental Encoder Cable	ASDBCAEN100X
Absolute Encoder Cable	ASD-B2EB100X
Encoder Connector	ASDBCAEN1000

(X = 3 indicates that the cable length is 3 m; X = 5 indicates that the cable length is 5 m)

**1 kW Servo Drive with 1 kW Low-inertia Motor**

Servo Drive	ASD-B2-1021-F
Low-inertia Motor	ECMA-C△1010□S
Motor Power Cable (without brake)	ASDBCAPW120X
Motor Power Cable (with brake)	ASDBCAPW130X
Power Connector	ASD-CAPW1000
Incremental Encoder Cable	ASDBCAEN100X
Absolute Encoder Cable	ASD-B2EB100X
Encoder Connector	ASDBCAEN1000

(X = 3 indicates that the cable length is 3 m; X = 5 indicates that the cable length is 5 m)

**1 kW Servo Drive with 1 kW Low-inertia Motor**

Servo Drive	ASD-B2-1021-F
Low-inertia Motor	ECMA-C△0910□S
Motor Power Cable (without brake)	ASDBCAPW020X
Power Connector (without brake)	ASDBCAPW0000
Motor Power Cable (with brake)	ASDBCAPW030X
Power Connector (with brake)	ASDBCAPW0100
Incremental Encoder Cable	ASDBCAEN000X
Absolute Encoder Cable	ASD-B2EB000X
Encoder Connector	ASDBCAEN0000

(X = 3 indicates that the cable length is 3 m; X = 5 indicates that the cable length is 5 m)

**1 kW Servo Drive with 1 kW Medium-inertia Motor**

Servo Drive	ASD-B2-1021-F
Medium-inertia Motor	ECMA-E△1310□S
Motor Power Cable (without brake)	ASDBCAPW120X
Motor Power Cable (with brake)	ASDBCAPW130X
Power Connector	ASD-CAPW1000
Incremental Encoder Cable	ASDBCAEN100X
Absolute Encoder Cable	ASD-B2EB100X
Encoder Connector	ASDBCAEN1000

(X = 3 indicates that the cable length is 3 m; X = 5 indicates that the cable length is 5 m)

**1 kW Servo Drive with 900 W High-inertia Motor**

Servo Drive	ASD-B2-1021-F
High-inertia Motor	ECMA-G△1309□S
Motor Power Cable (without brake)	ASDBCAPW120X
Motor Power Cable (with brake)	ASDBCAPW130X
Power Connector	ASD-CAPW1000
Incremental Encoder Cable	ASDBCAEN100X
Absolute Encoder Cable	ASD-B2EB100X
Encoder Connector	ASDBCAEN1000

(X = 3 indicates that the cable length is 3 m; X = 5 indicates that the cable length is 5 m)

B

**1.5 kW Servo Drive with 1.5 kW Medium-inertia Motor**

Servo Drive	ASD-B2-1521-F
Medium-inertia Motor	ECMA-E△1315□S
Motor Power Cable (without brake)	ASDBCAPW120X
Motor Power Cable (with brake)	ASDBCAPW130X
Power Connector	ASD-CAPW1000
Incremental Encoder Cable	ASDBCAEN100X
Absolute Encoder Cable	ASD-B2EB100X
Encoder Connector	ASDBCAEN1000

(X = 3 indicates that the cable length is 3 m; X = 5 indicates that the cable length is 5 m)

**2 kW Servo Drive with 2 kW Low-inertia Motor**

Servo Drive	ASD-B2-2023-F
Low-inertia Motor	ECMA-C△1020□S
Motor Power Cable (without brake)	ASDBCAPW120X
Motor Power Cable (with brake)	ASDBCAPW130X
Power Connector	ASD-CAPW1000
Incremental Encoder Cable	ASDBCAEN100X
Absolute Encoder Cable	ASD-B2EB100X
Encoder Connector	ASDBCAEN1000

(X = 3 indicates that the cable length is 3 m; X = 5 indicates that the cable length is 5 m)

**2 kW Servo Drive with 2 kW Medium-inertia Motor**

Servo Drive	ASD-B2-2023-F
Medium-inertia Motor	ECMA-E△1320□S
Motor Power Cable (without brake)	ASDBCAPW120X
Motor Power Cable (with brake)	ASDBCAPW130X
Power Connector	ASD-CAPW1000
Incremental Encoder Cable	ASDBCAEN100X
Absolute Encoder Cable	ASD-B2EB100X
Encoder Connector	ASDBCAEN1000

(X = 3 indicates that the cable length is 3 m; X = 5 indicates that the cable length is 5 m)

**2 kW Servo Drive with 2 kW Medium-inertia Motor**

Servo Drive	ASD-B2-2023-F
Medium-inertia Motor	ECMA-E△1820□S
Motor Power Cable (without brake)	ASD-CAPW220X
Motor Power Cable (with brake)	ASD-CAPW230X
Power Connector	ASD-CAPW2000
Incremental Encoder Cable	ASDBCAEN100X
Absolute Encoder Cable	ASD-B2EB100X
Encoder Connector	ASDBCAEN1000

(X = 3 indicates that the cable length is 3 m; X = 5 indicates that the cable length is 5 m)

**2 kW Servo Drive with 1.3 kW Medium-high-inertia Motor**

Servo Drive	ASD-B2-2023-F
Medium-high-inertia Motor	ECMA-F△1313□S
Motor Power Cable (without brake)	ASDBCAPW120X
Motor Power Cable (with brake)	ASDBCAPW130X
Power Connector	ASD-CAPW1000
Incremental Encoder Cable	ASDBCAEN100X
Absolute Encoder Cable	ASD-B2EB100X
Encoder Connector	ASDBCAEN1000

(X = 3 indicates that the cable length is 3 m; X = 5 indicates that the cable length is 5 m)

**3 kW Servo Drive with 3 kW Low-inertia Motor**

Servo Drive	ASD-B2-3023-F
Low-inertia Motor	ECMA-C△1330□4
Motor Power Cable (without brake)	ASDBCAPW120X
Motor Power Cable (with brake)	ASDBCAPW130X
Power Connector	ASD-CAPW1000
Incremental Encoder Cable	ASDBCAEN100X
Absolute Encoder Cable	ASD-B2EB100X
Encoder Connector	ASDBCAEN1000

(X = 3 indicates that the cable length is 3 m; X = 5 indicates that the cable length is 5 m)

**3 kW Servo Drive with 3 kW Medium-inertia Motor**

Servo Drive	ASD-B2-3023-F
Medium-inertia Motor	ECMA-E△1830□S
Motor Power Cable (without brake)	ASD-CAPW220X
Motor Power Cable (with brake)	ASD-CAPW230X
Power Connector	ASD-CAPW2000
Cable for Incremental Encoder	ASDBCAEN100X
Cable for Absolute Encoder	ASD-B2EB100X
Encoder Connector	ASDBCAEN1000

(X = 3 indicates that the cable length is 3 m; X = 5 indicates that the cable length is 5 m)

**3 kW Servo Drive with 3 kW Medium-high-inertia Motor**

Servo Drive	ASD-B2-3023-F
Medium-high-inertia Motor	ECMA-F△1830□S
Motor Power Cable (without brake)	ASD-CAPW220X
Motor Power Cable (with brake)	ASD-CAPW230X
Power Connector	ASD-CAPW2000
Incremental Encoder Cable	ASDBCAEN100X
Absolute Encoder Cable	ASD-B2EB100X
Encoder Connector	ASDBCAEN1000

(X = 3 indicates that the cable length is 3 m; X = 5 indicates that the cable length is 5 m)

**Other Accessories (Applicable to ASDA-B2-F series)**

Description	Delta Part Number
PC Connection Cable	ASD-CARS0003
Regenerative Resistor 400 W 100 Ω	BR400W040
Regenerative Resistor 1 kW 1000 Ω	BR1K0W020

## Note:

1. The box (□) at the end of servo drive model names stands for the product code of ASDA-B2-F series. Please refer to the actual situation of purchasing.
2. The box (△) in servo motor name stands for encoder type. Please refer to Chapter 1 for detailed description.
3. The box (□) in servo motor name stands for brake or keyway / oil seal type.

# Maintenance and Inspection Appendix

---

# C



Basic Inspection .....	C-2
Maintenance.....	C-3
The Lifetime of Machinery Parts.....	C-3

## Basic Inspection

Item	Content
General inspection	Periodically check if the screws of the servo drive, the connection between the motor shaft and the mechanical system as well as the connection of terminal block and mechanical system are securely tightened.
	The gap of the control chamber and the installation of the cooling fan should be free from oil, water or metallic particles. Also, the servo drive shall be free from the cutting power of the power drill.
	If the control chamber is installed in the site which contains harmful gas or full of dust, please ensure the servo drive is free from the harmful gas and dust.
	When making detector (encoder) cable or wire rods, please ensure the wiring is correct. Otherwise, the motor may have sudden unintended acceleration or be burned down.
Inspection before operation (Not connected to power yet)	To avoid electric shock, the ground terminal of the servo drive should be firmly connected to the ground terminal of the control chamber. If the wiring is needed, wait at least 10 minutes after the drive is disconnected from the mains, or discharge the electricity by discharge device.
	The splicing parts of the wiring terminal should be isolated.
	Make sure the wiring is correct so as to avoid damage or any irregularity.
	Check if the electrically conductive objects such as screws, sheet metal or inflammable objects are not inside the servo drive.
	Check if the control switch is in OFF status.
	Do not place the servo drive or external regenerative resistor onto inflammable objects.
	To avoid the electromagnetic brake losing efficacy, please check if the stop function and circuit break function can work normally.
	If the peripheral devices are interfered by the electronic instruments, please reduce electromagnetic interference with devices.
Inspection before running the servo drive (Already connected to power)	Please make sure the external voltage level of the servo drive is correct.
	The detector (encoder) cable should avoid excessive stress. When the motor is running, please ensure the cable is not frayed by the machine or over extended.
	Please contact Delta if there is any vibration of the servo motor or unusual noise during operation.
	Make sure the setting of the parameters is correct. Different machinery has different characteristic, please adjust the parameter according to the characteristic of each machinery.
	Please reset the parameter when the servo drive is in the status of SERVO OFF, or it may cause malfunction.
	Please contact Delta if there is no contact sound or other irregular sound occurs when the relay is operating.
	Check if the power indicator and LED display works normally.

C

## Maintenance

- Please use and store the product in a proper site.
- Periodically clean the surface of the servo drive and servo motor so as to avoid dust and dirt.
- Do not disassemble any mechanical part during maintenance.
- Periodically clean the ventilation ports of the servo drive and do not use the product in a high-temperature site for a long time so as to avoid malfunction.

C

## The Lifetime of Machinery Parts

- **DC Bus Capacitor**  
DC bus capacitor will be deteriorated by the affection of ripple current. Its lifetime is determined by the surrounding temperature and operating conditions. If it is operating in an air-conditioned site, its lifetime can be up to 10 years.
- **Relay**  
The contact will be worn due to power-on or power-off which leads to poor contact. The lifetime of relay is influenced by the power supply capacity; thus, the accumulative time of turning on or off the power is about 100,000 times.
- **Cooling Fan**  
In continuous operation, the lifetime of the cooling fan is 2 to 3 years and it has to be replaced then. However, if there is any unusual noise or vibration during inspection, replacing a new one is a must.

(This page is intentionally left blank.)

C

# Revision History

---

The version number locates on the cover of the user manual. Please refer to the following description of its naming convention.

**DELTA\_IA-ASD\_ASDA-B2-F\_UM\_EN\_20150925**

(1)

(2)

(3)

(4)

(5)

(6)

(1) Company Name

(2) Category

(3) Series

(4) Type

Abbr.	Type
AN	Application Note
C	Catalogue
UM	User Manual / User Guide
MM	Maintenance Manual
OM	Operation Manual
PM	Programming Manual
I	Instruction Sheet / Installation Guide / Instruction Manual
Q	Quick Start

(5) Language

Abbr.	Language
EN	English
TC	Traditional Chinese
SC	Simplified Chinese
JP	Japanese
KOR	Korea
TUR	Turkish

(6) Date of Release (yyyymmdd)

Date of Release	Version	Revised Chapter / Section	Revision
September, 2015	V1.0 (First version)	-	-
-	-	-	-
-	-	-	-
-	-	-	-

# Index

## DMCNET Communication Protocol

CN6 Connector (DMCNET) 3-24~3-25  
Connecting to peripheral devices: CN6 connector (DMCNET) 3-2  
Connectors and terminals of servo drive - CN6 DMCNET connector 3-3  
DI signal: ORGP (Control method of DMCNET) 7-64  
DO signal: TPOS (Control method of DMCNET) 7-65  
DO signal: HOME (Control method of DMCNET) 7-66  
DO signal: OVF (Control method of DMCNET) 7-66  
DO signal: Cmd\_OK (Control method of DMCNET) 7-67  
DO signal: MC\_OK (Control method of DMCNET) 7-67  
Each Part of the Servo Drive – DMCNET connector (CN6) 1-7  
Parameter definition – DMC refers to DMCNET mode. 7-2

### Related Alarms

Abnormal DMCNET Bus hardware (AL185) 9-3, 9-13  
An error occurs when loading DMCNET data (AL201) 9-4, 9-13  
DMCNET SDO overflow (AL111) 9-3, 9-13  
DMCNET fails to synchronize (AL301) 9-4, 9-15  
DMCNET IP command fails (AL304) 9-4, 9-15  
The synchronized signal of DMCNET is sent too fast (AL302) 9-4, 9-15  
The synchronized signal of DMCNET is sent too slow (AL303) 9-4, 9-15

### Related Parameters

Alarm code display of drive (Seven-segment Display) (P0-01) 7-3, 7-10  
DMCNET protocol setting (P3-10) 7-9, 7-53  
DMCNET synchronize setting (P3-09) 7-9, 7-52  
DMCNET selection (P3-11) 7-9, 7-53  
DMCNET support setting (P3-12) 7-9, 7-53~7-54  
Resonance suppression with low-pass filter 6-22

### Related Parameters

Low-pass filter of resonance suppression (P2-25) 5-20, 7-5, 7-41

Specifications of ASDA-B2-F servo drive: command source (DMCNET Mode) A-2

## E-gear Ratio

Control structure of position mode 6-3  
Electronic gear ratio 6-5  
Position feed forward gain 5-20  
Pulse number 10-19

### Related Alarms

Excessive deviation of position command (AL009) 9-2, 9-6  
PR command overflows (AL235) 9-4, 9-14

### Related Parameters

Gear ratio (Numerator) (N1) (P1-44) 7-6, 7-31  
Gear ratio (Denominator) (M) (P1-45) 7-6, 7-31

## PUU

DO signal: OVF (0x12) 7-66  
PUU number 10-20  
Use communication to access absolute position 10-21  
System Initialization 10-18

### Related Parameters

Read data format selection (P2-70) 7-49  
Forward software limit (P5-08) 7-6, 7-59  
Reverse software limit (P5-09) 7-6, 7-59  
Absolute coordinate system status (P0-50) 7-19  
Encoder absolute position (Multiturn) (P0-51) 7-19  
Encoder absolute position (Pulse number within single turn or PUU) (P0-52) 7-20

Specifications of ASDA-B2-F servo drive A-2

## Homing

### Forward and Reverse limits

DO signal: WARN (0x11) 7-66

### Related Parameters

Alarm code display of drive (Seven-segment display) (P0-01) 7-3, 7-10~7-11  
Servo digital output status display (P0-46) 7-4, 7-18

### Related Alarms

Forward limit error (AL015) 9-2, 9-7  
Forward software limit (AL283) 9-4, 9-14  
Reverse limit error (AL014) 9-2, 9-7  
Reverse software limit (AL285) 9-4, 9-14

DI signal: HOME (0x09) 7-66

DI signal: ORGP (0x24) 7-64

How to replace a battery 10-14

Use communication to access absolute position 10-21

### Related Alarms

The absolute position is lost (AL060) 9-3, 9-12, 10-17  
The multi-turn count of absolute encoder overflows (AL062) 9-3, 9-12, 10-17

## JOG

JOG mode 4-11

JOG trial run without load 5-7

### Related Parameters

Servo motor jog control (P4-05) 7-9, 7-56  
Tuning procedure: Estimate the inertia ratio (JOG Mode) 5-10

## Mapping Parameter

Monitor display 4-7~4-9

### Related Parameters

Drive status (P0-02) 7-3, 7-11  
Mapping parameter#1 (P0-25) 7-3, 7-14  
Mapping parameter#2 (P0-26) 7-3, 7-14  
Mapping parameter#3 (P0-27) 7-3, 7-14  
Mapping parameter#4 (P0-28) 7-3, 7-14  
Mapping parameter#5 (P0-29) 7-3, 7-15  
Mapping parameter#6 (P0-30) 7-3, 7-15  
Mapping parameter#7 (P0-31) 7-3, 7-15  
Mapping parameter#8 (P0-32) 7-3, 7-15  
Target setting of mapping parameter P0-25 (P0-35) 7-3, 7-15  
Target setting of mapping parameter P0-26 (P0-36) 7-3, 7-16  
Target setting of mapping parameter P0-27 (P0-37) 7-3, 7-16  
Target setting of mapping parameter P0-28 (P0-38) 7-3, 7-17  
Target setting of mapping parameter P0-29 (P0-39) 7-4, 7-17  
Target setting of mapping parameter P0-30 (P0-40) 7-4, 7-17  
Target setting of mapping parameter P0-31 (P0-41) 7-4, 7-17  
Target setting of mapping parameter P0-32 (P0-42) 7-4, 7-18

## Monitoring Variables

Monitor display 4-7~4-9

Monitoring variable: 038 (26h) (voltage level of battery) 10-17

Parameter setting procedure 4-3~4-5

### Related Parameters

Drive status (P0-02) 7-3, 7-11  
Status monitor register 1 (P0-09) 7-3, 7-12  
Status monitor register 2 (P0-10) 7-3, 7-12  
Status monitor register 3 (P0-11) 7-3, 7-12  
Status monitor register 4 (P0-12) 7-3, 7-12  
Status monitor register 5 (P0-13) 7-3, 7-13  
Status Monitor Register 1 Selection (P0-17) 7-3, 7-13  
Status Monitor Register 2 Selection (P0-18) 7-3, 7-13  
Status Monitor Register 3 Selection (P0-19) 7-3, 7-13  
Status Monitor Register 4 Selection (P0-20) 7-3, 7-13  
Status Monitor Register 5 Selection (P0-21) 7-3, 7-14

Servo drive alarm list for absolute function and monitoring variables 10-17

## Position Mode

Control structure of position mode 6-3

DI signal: GAINUP (0x03) 7-42, 7-63

DO signal: TPOS (0x05) 7-18, 7-32~7-34, 7-65

DO signal: OVF (0x12) 7-66

DO signal: Cmd\_OK (0x15) 7-32~7-33, 7-67

Gain adjustment of position loop 6-6

Low-frequency vibration suppression in position mode 6-7

Position command processing unit 6-3

Position control gain 5-19

Position control parameter (List) 7-6

Parameter definition – Tz refers to position control mode 7-2

Position mode 6-3~6-5  
S-curve filter (Position) 6-4, 6-12  
Selection of operation mode: position mode 6-2  
Specifications of ASDA-B2-F servo drive: position control mode A-2

#### Related Alarms

Excessive deviation of position command (AL009) 9-2, 9-6  
PR command overflows (AL235) 9-4, 9-14  
PR positioning is over time (AL245) 9-4, 9-14

#### Related Parameters

Anti-interference gain (P2-26) 5-20, 7-5, 7-41  
Condition of excessive position control deviation warning (P2-35) 7-45  
Position command moving filter (P1-68) 7-4, 7-36  
Position completed range (P1-54) 7-8, 7-34  
Position loop gain (P2-00) 5-19, 7-5, 7-37  
Position feed forward gain (P2-02) 7-5, 7-37  
Smooth constant of position command (Low-pass Filter) (P1-08) 7-4, 7-24

### Regenerative Resistor

1 ~1.5 kW models (with built-in regenerative resistor and fan) 3-13  
200 W or models below (without built-in regenerative resistor nor fan) 3-11  
2 ~3 kW models (with built-in regenerative resistor and fan) 3-14  
Connecting to peripheral devices: regenerative resistor (optional) 3-2  
400 ~750 W models (with built-in regenerative resistor but no fan) 3-12  
Connectors and terminals of servo drive 3-3  
Each Part of the Servo Drive – regenerative resistor 1-7  
Selection of regenerative resistor 2-7~2-11  
Specifications of ASDA-B2-F servo drive: regenerative resistor A-2  
Regenerative resistor (Applicable to ASDA-B2-F series) B-18

#### Related Parameters

Regenerative resistor value (P1-52) 7-33  
Regenerative resistor capacity (P1-53) 7-33~7-34

#### Related Alarms

Regeneration error (AL005) 9-2, 9-6

### Resonance Suppression

Filter and resonance suppression parameter (List) 7-4~7-5

#### Low-pass filter

Command end low-pass filter 6-13  
Control structure of torque mode 6-24  
Gain adjustment of speed loop 6-14  
Low-pass filter 6-6

#### Notch filter

Control structure of position mode 6-3  
Control structure of speed mode 6-11  
Low-pass filter of resonance suppression 5-20  
Mechanical resonance suppression method 5-17  
Procedure of auto suppressing the resonance 5-16  
Procedure of auto resonance suppression 6-19

#### Related Parameters

Auto resonance suppression mode setting (P2-47) 7-5, 7-46  
Low-pass filter of resonance suppression (P2-25) 5-20, 7-5, 7-41  
Resonance suppression (Notch Filter) (1) (P2-23) 7-4, 7-41  
Resonance suppression (Notch Filter) attenuation rate (1) (P2-24) 7-5, 7-41  
Resonance suppression (Notch Filter) (2) (P2-43) 7-5, 7-45  
Resonance suppression (Notch Filter) attenuation rate (2) (P2-44) 7-5, 7-45  
Resonance suppression (Notch Filter) (3) (P2-45) 7-5, 7-45  
Resonance suppression (Notch Filter) attenuation rate (3) (P2-46) 7-5, 7-45  
Resonance suppression detection level (P2-48) 7-5, 7-46  
Resonance suppression 6-11, 6-18~6-22  
Resonance suppression with notch filter 6-21  
Tuning mode and parameters 5-18

### Speed Mode

Control structure of speed mode 6-11  
DI signal: SPD0/SPD1 (0x14, 0x15) 7-63  
DO signal: SP\_OK (0x19) 7-67  
Gain adjustment of speed loop 6-14

Parameter definition – Sz refers to speed control mode 7-2  
Position feed forward gain (P2-07) 7-5, 7-28, 6-15~6-17

#### Related Alarms

Over speed (AL007) 9-2, 9-6

#### Related Parameters

Acceleration constant of S-Curve (P1-34) 7-4, 7-28  
Acceleration / Deceleration constant of S-Curve (P1-36) 7-4, 7-29  
Acceleration / Deceleration smooth constant of speed command (Low-pass Filter) (P1-06) 7-4, 7-24  
Deceleration constant of S-Curve (P1-35) 7-4, 7-28  
Internal speed command 1~3 (P1-09~P1-11) 7-7, 7-24~7-25  
Maximum speed limit (P1-55) 7-6, 7-7, 7-34  
Speed and torque limit setting (P1-02) 7-6, 7-7, 7-23  
Speed loop gain (P2-04) 5-19, 7-5, 7-37  
Speed integral compensation (P2-06) 5-20, 7-5, 7-38  
Speed feed forward gain (P2-07) 7-5, 7-38

Selection of speed command 6-10

Selection of operation mode: speed mode (No analog input) 6-2

Smooth speed command 6-12

Specifications of ASDA-B2-F servo drive: speed control mode A-2

Speed mode 6-10~6-17

Speed loop gain (P2-04) 7-5, 7-37, 5-19

Speed control parameter (List) 7-7

Timing diagram of speed mode 6-13

Trial run without load (Speed Mode) - speed command selection 5-9

Trial run without load (Speed Mode) 5-8

Wiring diagrams (CN1) 3-18

### Torque Mode

Control structure of torque mode 6-24

DI signal: TCM0/TCM1 (0 x16, 0x17) 7-63

DO signal: TQL (0x07) 7-65

Parameter definition – Tz refers to torque control mode 7-2

Specifications of ASDA-B2-F servo drive: torque control mode A-2

#### Related Parameters

Internal torque limit 1~3 (P1-12~P1-14) 7-6, 7-7, 7-25~7-26  
Speed and torque limit setting (P1-02) 7-6, 7-7, 7-23  
Smooth constant of torque command (Low-pass Filter) (P1-07) 7-4, 7-24

Selection of torque command 6-23

Selection of operation mode: torque mode (No analog input) 6-2

Smooth torque command 6-25

Timing diagram of torque mode 6-25

Torque mode 6-23~6-25

Torque control parameter (List) 7-7

Wiring diagrams (CN1) 3-18

### Tuning

#### Auto Gain Adjustment

##### Related Parameters

Anti-interference gain (P2-26) 5-20, 7-5, 7-41  
Gain adjustment of speed loop 6-14  
Limit of inertia ratio 5-15~5-16  
Speed mode 6-10  
Tuning mode and parameters 5-18

#### Bandwidth

Gain adjustment of position loop 6-6~6-7

Manual mode 6-14

Resonance Suppression 6-18

Specifications of ASDA-B2-F servo drive A-2

##### Related Parameters

Speed detection filter (P2-49) 7-5, 7-46  
Speed loop frequency response setting in auto and semi-auto mode (P2-31) 7-6, 7-43  
Tuning mode selection (P2-32) 7-6, 7-43~7-44

Flowchart of auto tuning 5-13

Flowchart of semi-auto tuning 5-14

Flowchart of tuning procedure 5-11

Trial operation and tuning 5-1

Tuning procedure 5-10

Time domain 6-16~6-17