

Product datasheet

Specifications



servo motor BCH2, Lexium, 60mm,
200W, with oil seal, with key, 20 bit
MT encoder, leads connection

BCH2LD0233MA5C

Main

Range compatibility Lexium 28
Easy Lexium 26

Device short name BCH2

Product or component type Servo motor

Complementary

Maximum mechanical speed 5000 rpm

[Us] rated supply voltage 220 V
110 V

Network number of phases Three phase
Single phase

Continuous stall current 1.11 A

Continuous stall torque 0.64 N.m for LXM26D at 1.5 A, 220 V, single phase
0.64 N.m for LXM26D at 1.5 A, 220 V, three phase
0.64 N.m for LXM28... at 1.5 A, 220 V, single phase
0.64 N.m for LXM28... at 1.5 A, 220 V, three phase
0.64 N.m for LXM28... at 3.6 A, 110 V, single phase

Continuous power 200 W

Peak stall torque 1.92 N.m for LXM26D at 1.5 A, 220 V, single phase
1.92 N.m for LXM26D at 1.5 A, 220 V, three phase
1.92 N.m for LXM28... at 1.5 A, 220 V, single phase
1.92 N.m for LXM28... at 1.5 A, 220 V, three phase
1.92 N.m for LXM28... at 3.6 A, 110 V, single phase

Nominal output power 200 W for LXM26D at 1.5 A, 220 V, single phase
200 W for LXM26D at 1.5 A, 220 V, three phase
200 W for LXM28... at 1.5 A, 220 V, single phase
200 W for LXM28... at 1.5 A, 220 V, three phase
200 W for LXM28... at 3.6 A, 110 V, single phase

Nominal torque 0.64 N.m for LXM26D at 1.5 A, 220 V, single phase
0.64 N.m for LXM26D at 1.5 A, 220 V, three phase
0.64 N.m for LXM28... at 1.5 A, 220 V, single phase
0.64 N.m for LXM28... at 1.5 A, 220 V, three phase
0.64 N.m for LXM28... at 3.6 A, 110 V, single phase

Nominal speed 3000 rpm for LXM26D at 1.5 A, 220 V, single phase
3000 rpm for LXM26D at 1.5 A, 220 V, three phase
3000 rpm for LXM28... at 1.5 A, 220 V, single phase
3000 rpm for LXM28... at 1.5 A, 220 V, three phase
3000 rpm for LXM28... at 3.6 A, 110 V, single phase

Maximum current Irms 4.31 A for LXM28... at 0.2 kW, 220 V
4.31 A for LXM28... at 0.2 kW, 110 V

Maximum permanent current 1.3 A

Disclaimer: This documentation is not intended as a substitute for and is not to be used for determining suitability or reliability of these products for specific user applications

Product compatibility	LXM26D servo drive motor at 0.2 kW, 220 V, single phase LXM26D servo drive motor at 0.2 kW, 220 V, three phase LXM28... servo drive motor at 0.2 kW, 220 V, single phase LXM28... servo drive motor at 0.2 kW, 220 V, three phase LXM28... servo drive motor at 0.2 kW, 110 V, single phase
Shaft end	Keyed
Shaft diameter	14 mm
Shaft length	30 mm
Key width	5 mm
Feedback type	20 bits multi turn absolute encoder
Holding brake	Without
Mounting support	Asian standard flange
Motor flange size	60 mm
Electrical connection	Free lead
Torque constant	0.58 N.m/A at 20 °C
Back emf constant	35 V/krpm at 20 °C
Number of motor poles	4.0
Rotor inertia	0.16 kg.cm ²
Stator resistance	12.2 Ohm at 20 °C
Stator inductance	22.68 mH at 20 °C
Stator electrical time constant	1.84 ms at 20 °C
Maximum radial force Fr	200 N at 3000 rpm
Maximum axial force Fa	70 N
Brake pull-in power	11.2 W
Type of cooling	Natural convection
Length	104 mm
Number of motor stacks	1
Centring collar diameter	50 mm
Centring collar depth	5.5 mm
Number of mounting holes	4
Mounting holes diameter	5.5 mm
Circle diameter of the mounting holes	70 mm
Distance shaft shoulder-flange	5.5 mm
Net weight	1.02 kg
Sizing reference	BCH2
Network number of phases	1
Accuracy error [angular]	0.044 °
Temperature copper hot	135 °C
Temperature magnet hot	100 °C
Temperature magnet rt	20 °C
Inertia	0.0 kg.cm ² of brake 0.15 kg.cm ² of motor

Environment

IP degree of protection	IP50 IM V3 IP65 IM B5, IM V1
-------------------------	---------------------------------

Ambient air temperature for operation	-20...40 °C
---------------------------------------	-------------

Packing Units

Unit Type of Package 1	PCE
------------------------	-----

Number of Units in Package 1	1
------------------------------	---

Package 1 Height	11.2 cm
------------------	---------

Package 1 Width	14.5 cm
-----------------	---------

Package 1 Length	26.5 cm
------------------	---------

Package 1 Weight	1.35 kg
------------------	---------

Unit Type of Package 2	S03
------------------------	-----

Number of Units in Package 2	5
------------------------------	---

Package 2 Height	30 cm
------------------	-------

Package 2 Width	30 cm
-----------------	-------

Package 2 Length	40 cm
------------------	-------

Package 2 Weight	7.223 kg
------------------	----------

Unit Type of Package 3	P06
------------------------	-----

Number of Units in Package 3	40
------------------------------	----

Package 3 Height	80 cm
------------------	-------

Package 3 Width	60 cm
-----------------	-------

Package 3 Length	72 cm
------------------	-------

Package 3 Weight	64.784 kg
------------------	-----------

Contractual warranty

Warranty (in months)	18
----------------------	----



Environmental Data

Schneider Electric aims to achieve Net Zero status by 2050 through supply chain partnerships, lower impact materials, and circularity via our ongoing “Use Better, Use Longer, Use Again” campaign to extend product lifetimes and recyclability.

[Environmental Data explained >](#)

[How we assess product sustainability >](#)



Environmental footprint

Total lifecycle Carbon footprint	1 603 kg CO2 eq.
Carbon footprint of the manufacturing phase [A1 to A3]	8 kg CO2 eq.
Carbon footprint of the distribution phase [A4]	0.2 kg CO2 eq.
Carbon footprint of the installation phase [A5]	0 kg CO2 eq.
Carbon footprint of the use phase [B2, B3, B4, B6]	1 594 kg CO2 eq.
Carbon footprint of the end-of-life phase [C1 to C4]	0.2 kg CO2 eq.
Environmental Disclosure	Product Environmental Profile

Use Better



Materials and Substances

Packaging made with recycled cardboard	Yes
Packaging without single use plastic	No
EU RoHS Directive	Compliant
REACH Regulation	Free of Substances of Very High Concern above the threshold
PVC free	Yes

Use Longer



Lifetime extension

Repair	No
--------	----

Use Again



Repack and remanufacture

End of life manual availability	End of Life Information
Take-back	No

Dimensions Drawings

Dimensions

Dimensions of Motor

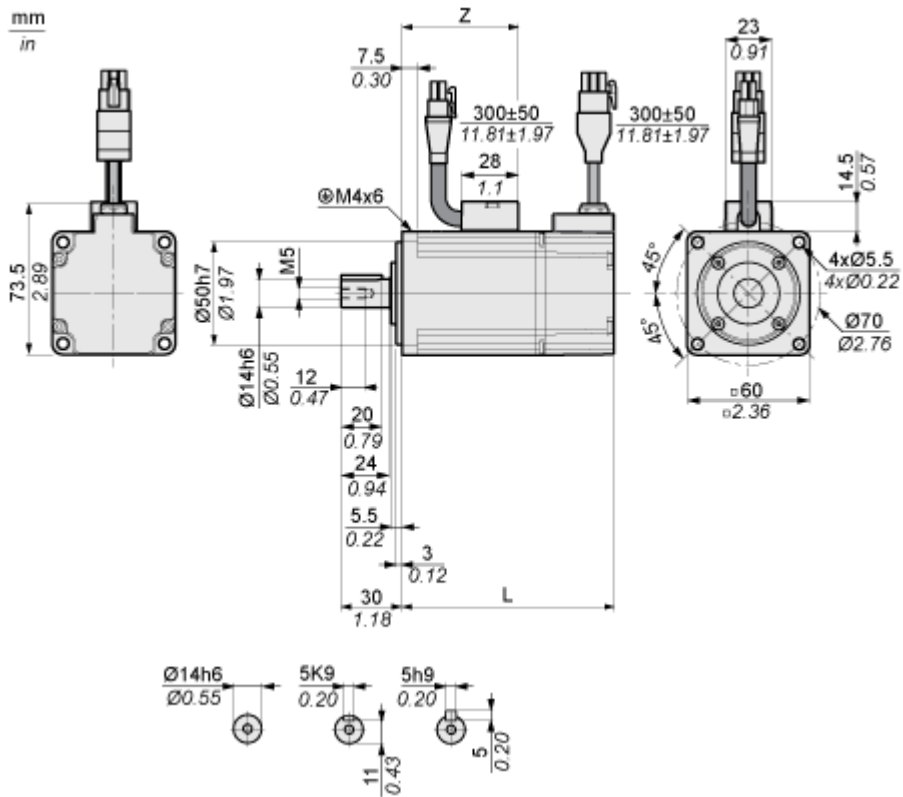

	mm	in.
L (without holding brake)	104	4.09
L (with holding brake)	140	5.51
Z	57	2.24

Performance Curves

Torque/Speed Curves with 230 V Single/Three Phase Supply Voltage

Servo Motor with LXM28AU02 Servo Drive

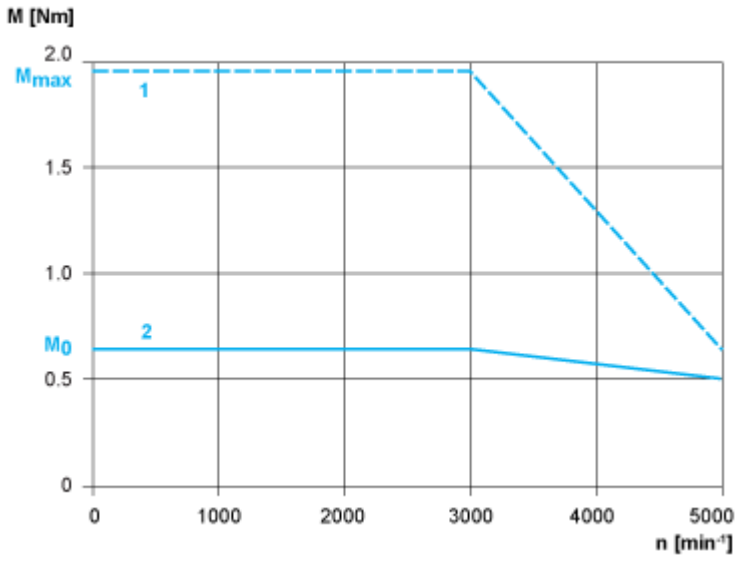

- 1 : Peak torque
- 2 : Continuous torque