

Toothed belt axes ELGA-TB

FESTO



Festo core product range
Covers 80% of your automation tasks

Worldwide:

Always in stock

Superb:

Festo quality at an attractive price

Easy:

Simplified procurement and warehousing

★ Generally ready for dispatch from the factory within 24 hours

In stock at 13 Service Centres worldwide

More than 2200 products

★ Generally ready for dispatch from the factory within 5 days

Assembled for you at 4 Service Centres worldwide

Up to 6×10^{12} variants per product family

Just look
for the
star!

Selection aid

Overview of toothed belt and spindle axes

Toothed belt axes

- Speeds of up to 10 m/s
- Acceleration of up to 50 m/s²
- Repetition accuracy of up to ±0.08 mm
- Strokes of up to 8500 mm (longer strokes on request)
- Flexible motor mounting

Spindle axes

- Speeds of up to 2 m/s
- Acceleration of up to 20 m/s²
- Repetition accuracy of up to ±0.003 mm
- Strokes of up to 3000 mm

Coordinate system

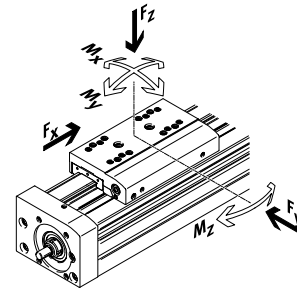

Toothed belt axes

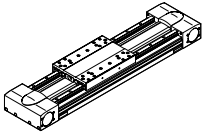
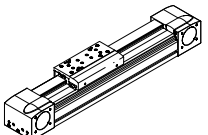
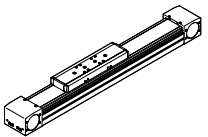
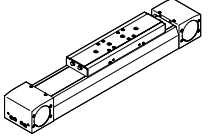
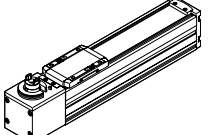
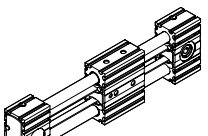
Type	F _x [N]	v [m/s]	M _x [Nm]	M _y [Nm]	M _z [Nm]	Characteristics
Heavy-duty recirculating ball bearing guide						
EGC-HD-TB						
	450 1000 1800	3 5 5	140 300 900	275 500 1450	275 500 1450	<ul style="list-style-type: none"> • Flat drive unit with rigid, closed profile • Precision DUO guide rail with high load capacity • Ideal as a base axis for linear gantries and cantilever axes
Recirculating ball bearing guide						
EGC-TB-KF						
	50 100 350 800 2500	3 5 5 5 5	3.5 16 36 144 529	10 132 228 680 1820	10 132 228 680 1820	<ul style="list-style-type: none"> • Rigid, closed profile • Precision guide rail with high load capacity • Small drive pinions reduce required driving torque • Space-saving position sensing
ELGA-TB-KF						
	350 800 1300 2000	5 5 5 5	16 36 104 167	132 228 680 1150	132 228 680 1150	<ul style="list-style-type: none"> • Internal guide and toothed belt • Precision guide rail with high load capacity • Guide and toothed belt protected by cover strip • High feed forces
ELGA-TB-KF-F1						
	260 600 1000	5 5 5	16 36 104	132 228 680	132 228 680	<ul style="list-style-type: none"> • Suitable for use in the food zone • "Clean look": smooth, easy-to-clean surfaces • Internal guide and toothed belt • Precision guide rail with high load capacity • Guide and toothed belt protected by cover strip
ELGC-TB-KF						
	75 120 250	1.2 1.5 1.5	5.5 29.1 59.8	4.7 31.8 56.2	4.7 31.8 56.2	<ul style="list-style-type: none"> • Internal guide and toothed belt • Precision guide rail with high load capacity • Guide and toothed belt protected by cover strip
ELGR-TB						
	50 100 350	3 3 3	2.5 5 15	20 40 124	20 40 124	<ul style="list-style-type: none"> • Cost-optimised rod guide • Ready-to-install unit • Linear bushings with high load capacity for dynamic operation

Selection aid

Overview of toothed belt and spindle axes

Toothed belt axes

- Speeds of up to 10 m/s
- Acceleration of up to 50 m/s²
- Repetition accuracy of up to ±0.08 mm
- Strokes of up to 8500 mm (longer strokes on request)
- Flexible motor mounting

Spindle axes

- Speeds of up to 2 m/s
- Acceleration of up to 20 m/s²
- Repetition accuracy of up to ±0.003 mm
- Strokes of up to 3000 mm

Coordinate system

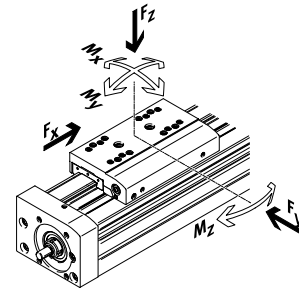

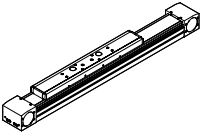
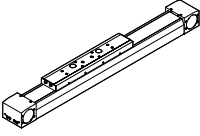
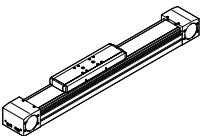
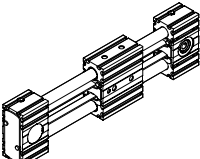
Toothed belt axes						
Type	F_x [N]	v [m/s]	M_x [Nm]	M_y [Nm]	M_z [Nm]	Characteristics
Roller guide						
ELGA-TB-RF						
	350 800 1300	10 10 10	11 30 100	40 180 640	40 180 640	<ul style="list-style-type: none"> • Heavy-duty roller bearing guide • Guide and toothed belt protected by cover strip • Speeds of up to 10 m/s • Lower weight than axes with guide rails
ELGA-TB-RF-F1						
	260 600 1000	10 10 10	8.8 24 80	32 144 512	32 144 512	<ul style="list-style-type: none"> • Suitable for use in the food zone • "Clean look": smooth, easy-to-clean surfaces • Heavy-duty roller bearing guide • Guide and toothed belt protected by cover strip • Lower weight than axes with guide rails
Plain-bearing guide						
ELGA-TB-G						
	350 800 1300	5 5 5	5 10 120	30 60 120	10 20 40	<ul style="list-style-type: none"> • Guide and toothed belt protected by cover strip • For simple handling tasks • As a drive component for external guides • Insensitive to harsh ambient conditions
ELGR-TB-GF						
	50 100 350	1 1 1	1 2.5 1	10 20 40	10 20 40	<ul style="list-style-type: none"> • Cost-optimised rod guide • Ready-to-install unit • Heavy-duty plain bearings for use in harsh environmental conditions

Selection aid

Overview of toothed belt and spindle axes

Toothed belt axes

- Speeds of up to 10 m/s
- Acceleration of up to 50 m/s²
- Repetition accuracy of up to ±0.08 mm
- Strokes of up to 8500 mm (longer strokes on request)
- Flexible motor mounting

Spindle axes

- Speeds of up to 2 m/s
- Acceleration of up to 20 m/s²
- Repetition accuracy of up to ±0.003 mm
- Strokes of up to 3000 mm

Coordinate system

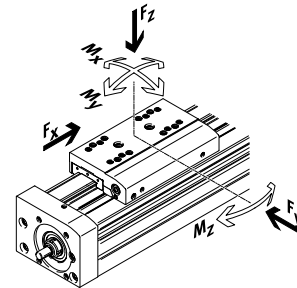

Spindle axes

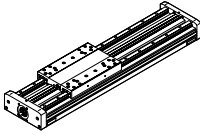
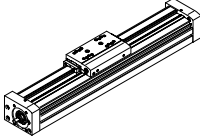
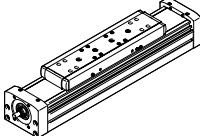
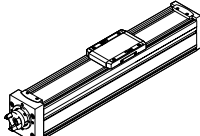
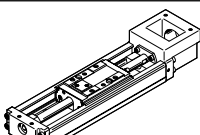
Type	F _x [N]	v [m/s]	M _x [Nm]	M _y [Nm]	M _z [Nm]	Characteristics
Heavy-duty recirculating ball bearing guide						
EGC-HD-BS						
	400 650 1500	0.5 1.0 1.5	140 300 900	275 500 1450	275 500 1450	<ul style="list-style-type: none"> • Flat drive unit with rigid, closed profile • Precision DUO guide rail with high load capacity • Ideal as a base axis for linear gantries and cantilever axes
Recirculating ball bearing guide						
EGC-BS-KF						
	400 650 1500 3000	0.5 1.0 1.5 2.0	16 36 144 529	132 228 680 1820	132 228 680 1820	<ul style="list-style-type: none"> • Rigid, closed profile • Precision guide rail with high load capacity • For the highest requirements in terms of feed force and accuracy • Space-saving position sensing
ELGA-BS-KF						
	650 1600 3400 6400	0.5 1.0 1.5 2.0	16 36 104 167	132 228 680 1150	132 228 680 1150	<ul style="list-style-type: none"> • Internal guide and ball screw drive • Precision guide rail with high load capacity • For the highest requirements in terms of feed force and accuracy • Guide and ball screw drive protected by cover strip • Space-saving position sensing
ELGC-BS-KF						
	40 100 200 350	0.6 0.6 0.8 1.0	1.3 5.5 29.1 59.8	1.1 4.7 31.8 56.2	1.1 4.7 31.8 56.2	<ul style="list-style-type: none"> • Internal guide and ball screw drive • Guide and ball screw drive protected by cover strip • Space-saving position sensing
EGSK						
	57 133 184 239 392	0.33 1.10 0.83 1.10 1.48	13 28.7 60 79.5 231	3.7 9.2 20.4 26 77.3	3.7 9.2 20.4 26 77.3	<ul style="list-style-type: none"> • Spindle axes with maximum precision, compactness and rigidity • Recirculating ball bearing guide and ball screw drive without caged ball bearings • Standard designs in stock

Key features

At a glance

ELGA-TB-KF/-KF-F1 – Recirculating ball bearing guide



- Internal, precision recirculating ball bearing guide with high load capacity for high torque loads
- Stainless steel cover strip provides basic protection for guide and toothed belt
- Easy maintenance thanks to easily accessible lubrication connections
- One additional slide can be selected
- Suitable for use in the food zone (ELGA-...-F1)
- Toothed belt material can be selected from:
 - Chloroprene rubber for long service life
 - Coated PU with steel reinforcements for long service life and resilience to certain cooling lubricants
 - Uncoated PU, FDA-compliant

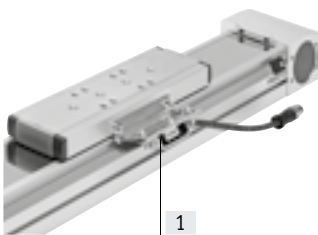

- [1] Displacement encoder (optional)
The position of the slide can be sensed directly when using the incremental displacement encoder. This means that all elasticities of the drive train can be detected and can be corrected by the motor controller (→ page 15)

ELGA-TB-RF/-RF-F1 – Roller guide



- For high acceleration and speeds
- Guide backlash = 0 mm
- Very good operating behaviour under torque load
- Suitable for use in the food zone (ELGA-...-F1)
- Sturdy alternative to the recirculating ball bearing guide
- Drive for external guides, especially for high speeds
- Toothed belt material can be selected from:
 - Chloroprene rubber for long service life
 - Coated PU with steel reinforcements for long service life and resilience to certain cooling lubricants
 - Uncoated PU, FDA-compliant

ELGA-TB-G – Plain-bearing guide



- For small and medium loads
- Low guide backlash
- Drive for external guides
- For simple handling tasks
- Toothed belt material can be selected from:
 - Chloroprene rubber for long service life
 - Coated PU with steel reinforcements for long service life and resilience to certain cooling lubricants

Sealing air connections

[1] Sealing air connections

- Application of negative pressure minimises the dispersal of abraded particles into the environment
- Provided at both ends
- Application of positive pressure prevents dirt from getting into the axis

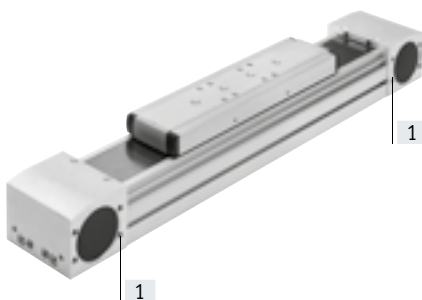

Flexible motor connection

The motor position can be freely selected on 4 sides and can be changed at any time.



Key features

Complete system comprising toothed belt axis, motor, motor controller and motor mounting kit



Motor → Page 94

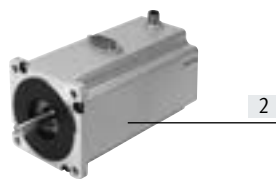
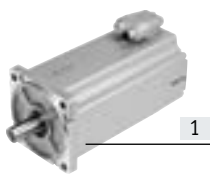

- [1] Servo motor EMME-AS, EMMS-AS
- [2] Stepper motor EMMS-ST

Note
A range of specially matched complete solutions is available for the toothed belt axis ELGA and the motors.

Motor controller Data sheets → Internet: motor controller

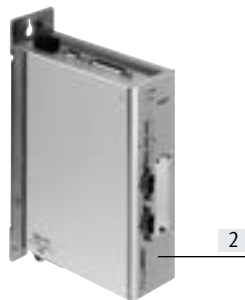

- [1] Servo motor controller CMMP-AS
- [2] Stepper motor controller CMMS-ST

Motor mounting kit → Page 94

Axial kit

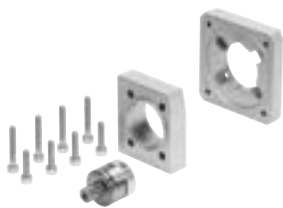

- Kit comprising:
- Motor flange
 - Coupling housing
 - Coupling
 - Screws

Key features

Characteristic values of the axes

The specifications shown in the table are maximum values.

The precise values for each of the variants can be found in the relevant data sheet in the catalogue.

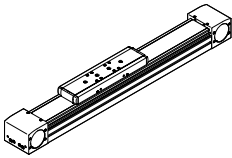
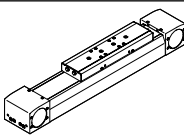
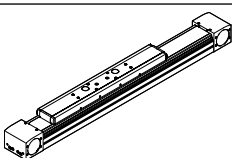
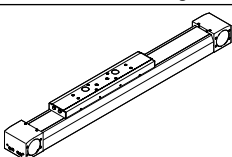
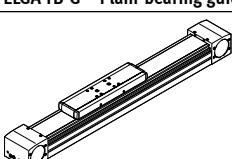
Version	Size	Working stroke [mm]	Speed [m/s]	Repetition accuracy [mm]	Feed force [N]	Guide characteristics					→ Page/ Internet
						Forces and torques					
						F _y [N]	F _z [N]	M _x [Nm]	M _y [Nm]	M _z [Nm]	
ELGA-TB-KF – Recirculating ball bearing guide											
	70	50 ... 5000	5	±0.08	350	1500	1850	16	132	132	10
	80	50 ... 8500	5	±0.08	800	2500	3050	36	228	228	
	120	50 ... 8500	5	±0.08	1300	5500	6890	104	680	680	
	150	50 ... 7000	5	±0.08	2000	11000	11000	167	1150	1150	
ELGA-TB-KF-F1 – Recirculating ball bearing guide, suitable for use in the food zone											
	70	50 ... 5000	5	±0.08	260	1500	1850	16	132	132	30
	80	50 ... 8500	5	±0.08	600	2500	3050	36	228	228	
	120	50 ... 8500	5	±0.08	1000	5500	6890	104	680	680	
ELGA-TB-RF – Roller guide											
	70	50 ... 7000	10	±0.08	350	500	500	11	40	40	46
	80	50 ... 7000	10	±0.08	800	800	800	30	180	180	
	120	50 ... 7400	10	±0.08	1300	2000	2000	100	640	640	
ELGA-TB-RF-F1 – Roller guide, suitable for use in the food zone											
	70	50 ... 7000	10	±0.08	260	400	400	8.8	32	32	64
	80	50 ... 7000	10	±0.08	600	640	640	24	144	144	
	120	50 ... 7400	10	±0.08	1000	1600	1600	80	512	512	
ELGA-TB-G – Plain-bearing guide											
	70	50 ... 8500	5	±0.08	350	80	400	5	30	10	80
	80	50 ... 8500	5	±0.08	800	200	800	10	60	20	
	120	50 ... 8500	5	±0.08	1300	380	1600	20	120	40	

 **Note**
Engineering software
PositioningDrives
www.festo.com

Key features

System product for handling and assembly technology

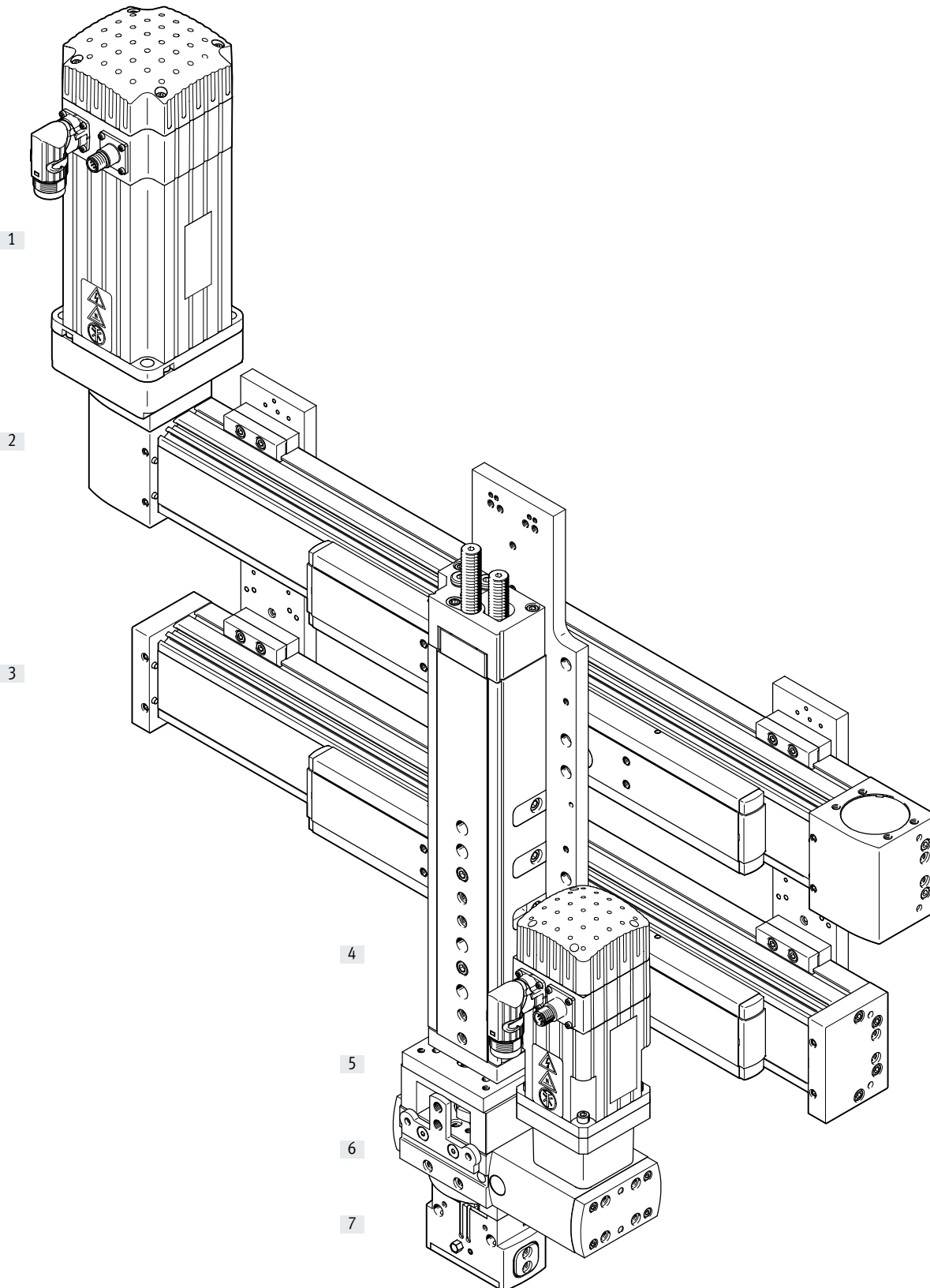

Key features

System components and accessories		Description	→ Internet
[1]	Motors	Servo and stepper motors, with or without gear unit	motor
[2]	Axes	Wide range of combinations possible within handling and assembly technology	axis
[3]	Guide axes	To support force and torque capacity in multi-axis applications	guide axis
[4]	Drives	Wide range of combinations possible within handling and assembly technology	drive
[5]	Adapter	For drive/drive and drive/gripper connections	gripper
[6]	Semi-rotary drives	Wide range of variations possible within handling and assembly technology	semi-rotary drive
[7]	Gripper	Wide range of variations possible within handling and assembly technology	gripper

Peripherals overview

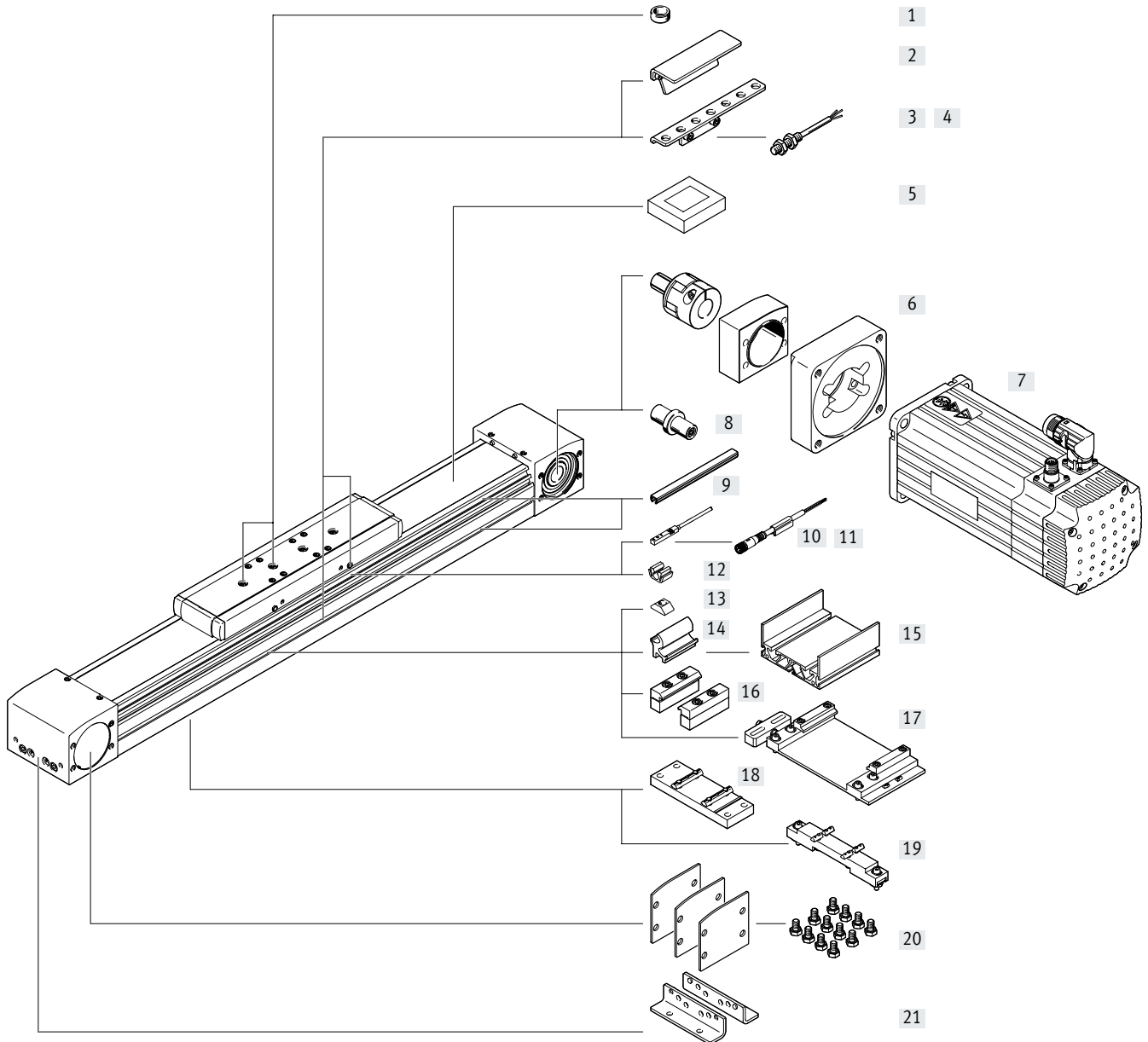
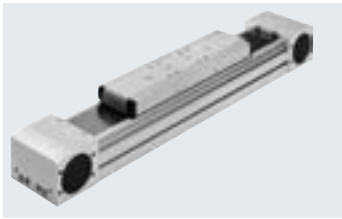

Peripherals overview

Accessories		
Type	Description	→ Page/Internet
[1] Centring pin/sleeve ZBS, ZBH	<ul style="list-style-type: none"> For centring loads and attachments on the slide Included in the scope of delivery: <ul style="list-style-type: none"> For size 70: 2x ZBS-5 For size 80, 120, 150: 2x ZBH-9 	108
[2] Switch lug SF-EGC	For sensing the slide position	105
[3] Sensor bracket HWS-EGC	For mounting the inductive proximity switches (round design) on the axis	106
[4] Proximity switch, M8 SIEN-M8	Inductive proximity switch, round design	110
[5] Clamping element EADT	Tool for retensioning the cover strip	108
[6] Axial kit EAMM	For axial motor mounting (comprises: coupling, coupling housing and motor flange)	94
[7] Motor EMME, EMMS	Motors specially matched to the axis, with or without gear unit, with or without brake	94
[8] Drive shaft EAMB	<ul style="list-style-type: none"> Can, if required, be used as an alternative interface No drive shaft is required for the axis/motor combinations → page 94 	99
[9] Slot cover ABP	For protection against contamination	108
[10] Proximity switch, T-slot SIES-8M	<ul style="list-style-type: none"> Inductive proximity switch, for T-slot The order code SA, SB includes 1 switch lug in the scope of delivery 	109
[11] Connecting cable NEBU, SIM	For proximity switch	110
[12] Clip SMBK	For mounting the proximity switch cable in the slot	108
[13] Slot nut NST	For mounting attachments	108
[14] Adapter kit DHAM	For mounting the support profile on the axis	109
[15] Support profile HMIA	For mounting and guiding an energy chain	109
[16] Profile mounting MUE	For mounting the axis on the side of the profile	101
[17] Adjusting kit EADC-E16	For mounting the axis on a vertical surface. Once mounted, the axis can be aligned horizontally	104
[18] Central support EAHF-L5	For mounting the axis on the profile from underneath	102
[19] Adjusting kit EADC-E15	Is height-adjustable. Can be used to easily compensate for any unevenness in the bearing surface	103
[20] Cover kit EASC-L5	For covering the sides of the drive cover	108
[21] Foot mounting HPE	<ul style="list-style-type: none"> For mounting the axis on the end cap With higher forces and torques, the axis should be mounted using the profile 	100



Type codes

001	Series	
ELGA	Gantry axis	
002	Drive system	
TB	Toothed belt	
003	Guide	
KF	Recirculating ball bearing guide	
004	Size	
70	70	
80	80	
120	120	
150	150	
005	Stroke	
...	50 ... 8500	
006	Stroke reserve	
...H	0 ... 999	
007	Additional slide	
	None	
ZR	1 slide right	
ZL	1 slide left	

008	Additional characteristics	
	None	
F1	Food-safe according to supplementary information on materials	
009	Displacement encoder	
	None	
M1	With displacement encoder, incremental, resolution 2.5 µm	
M2	With displacement encoder, incremental, resolution 10 µm	
010	Displacement encoder attachment position	
	None	
F	Front	
B	Rear	
011	Toothed belt material	
	Standard	
PU1	Uncoated PU, FDA-compliant	
PU2	Coated PU	
012	Operating instructions	
	With operating instructions	
DN	Without operating instructions	

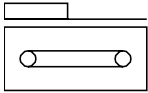
Data sheet

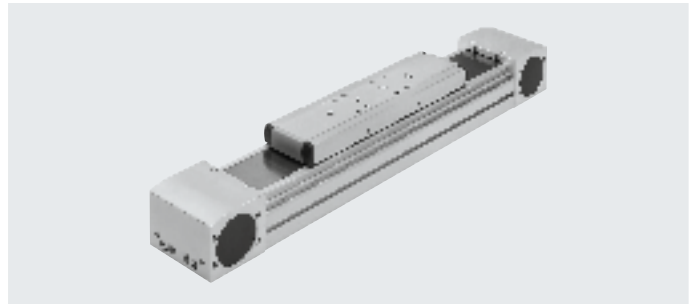

-  Size
70 ... 150
-  Stroke length
50 ... 8500 mm
-  www.festo.com

**General technical data**

Size	70	80	120	150
Design	Electromechanical axis with toothed belt			
Guide	Recirculating ball bearing guide			
Mounting position	Any			
Working stroke [mm]	50 ... 5000	50 ... 8500	50 ... 8500	50 ... 7000
Max. feed force F_x [N]	350	800	1300	2000
Max. no-load torque ¹⁾ [Nm]	0.6	1	2.8	4
Max. no-load resistance to shifting ¹⁾ [N]	41.9	50.3	76.2	108.3
Max. driving torque [Nm]	5.02	15.92	34.1	73.85
Max. speed [m/s]	5			
Max. acceleration [m/s ²]	50			
Repetition accuracy [mm]	±0.08			

1) At 0.2 m/s

Operating and environmental conditions

Ambient temperature ¹⁾ [°C]	-10 ... +60
Degree of protection	IP40
Duty cycle [%]	100

1) Note operating range of proximity switches

Weight [kg]

Size	70	80	120	150
Basic weight with 0 mm stroke ¹⁾	2.97	4.70	15.68	32.83
Additional weight per 1000 mm stroke	3.94	5.13	10.64	17.22
Moving mass				
ELGA-...	0.90	1.90	4.19	7.24
ELGA-...-ZL/ZR	0.74	1.53	3.24	5.84

1) Incl. slide

Toothed belt

Size	70	80	120	150
Pitch [mm]	3	5	5	8
Elongation ¹⁾				
ELGA-...	0.213	0.168	0.21	0.258
ELGA-...-PU2	0.105	0.1	0.122	0.083
Effective diameter [mm]	28.65	39.79	52.52	73.85
Feed constant [mm/rev]	90	125	165	232

1) At max. feed force

Data sheet

Mass moment of inertia		70	80	120	150
Size					
J_0	[kg mm ²]	243	982	4099	15426
J_H per metre stroke	[kg mm ² /m]	19	93	215	586
J_L per kg payload	[kg mm ² /kg]	205	396	690	1363
J_W for additional slide	[kg mm ²]	186	761	2891	9869

The mass moment of inertia J_A of the entire axis is calculated as follows:

$$J_A = J_0 + K \times J_W + J_H \times \text{working stroke [m]} + J_L \times m_{\text{payload [kg]}}$$

$K =$ Number of additional slides

Materials

Sectional view

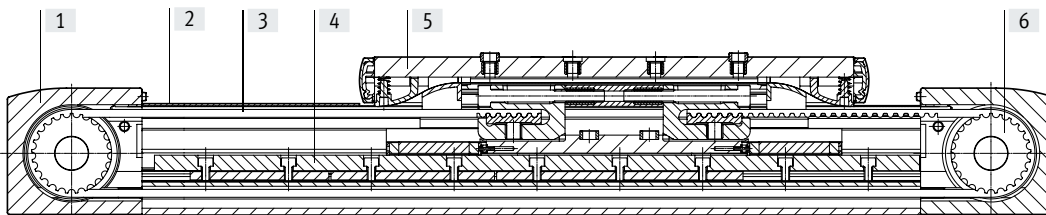

Axis Size	70	80	120	150
[1] Drive cover	Anodised wrought aluminium alloy			
[2] Cover strip	Stainless steel strip, non-corroding			
[3] Toothed belt				
ELGA-...	Polychloroprene with glass cord and nylon coating			
ELGA-...-PU2	Polyurethane with steel cord and nylon covering			
[4] Guide rail	Stainless steel	Tempered steel		
[5] Slide	Anodised wrought aluminium alloy			
[6] Belt pulley	High-alloy stainless steel			
Note on materials	RoHS-compliant			
	Contains paint-wetting impairment substances			

Data sheet

Dimensions → page 26

Technical data – Displacement encoder

Type		ELGA-...-M1	ELGA-...-M2
Resolution	[µm]	2.5	10
Max. travel speed with displacement encoder	[m/s]	4	4
Encoder signal		5 V TTL; A/A, B/B; reference signal (N/N) cyclical every 5 mm (zero pulse)	
Signal output		Line driver, alternating, resistant to sustained short circuit	
Electrical connection		8-pin plug, round design, M12	
Cable length	[mm]	160	

Operating and environmental conditions – Displacement encoder

Ambient temperature	[°C]	-10 ... +70
Degree of protection		IP64
CE marking (see declaration of conformity)		In accordance with EU EMC Directive ¹⁾

1) For information about the area of use, see the EC declaration of conformity at: www.festo.com/sp → Certificates.

If the devices are subject to usage restrictions in residential, commercial or light-industrial environments, further measures for the reduction of the emitted interference may be necessary.

Note regarding use

The spindle axis with displacement encoder is not designed for the following sample applications:

- Magnetic field

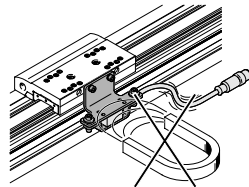

- Welding application

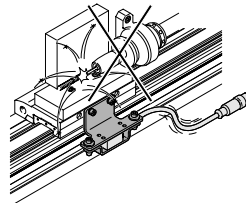

Data sheet

Characteristic load values

The indicated forces and torques refer to the centre of the guide. The point of application of force is the point where the centre of the guide and the longitudinal centre of the slide intersect. These values must not be exceeded during dynamic operation. Special attention must be paid to the cushioning phase.

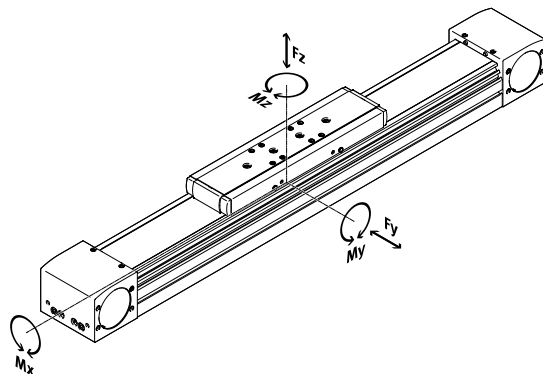

Distance from the slide surface to the centre of the guide

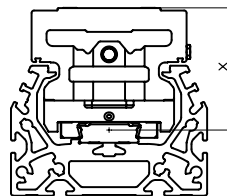

Distance from the slide surface to the centre of the guide

Size	70	80	120	150
Dimension x [mm]	37	50	70	86

Max. permissible forces and torques for a service life of 5000 km

Size	70	80	120	150
$F_{y,max.}$ [N]	1500	2500	5500	11000
$F_{z,max.}$ [N]	1850	3050	6890	11000
$M_{x,max.}$ [Nm]	16	36	104	167
$M_{y,max.}$ [Nm]	132	228	680	1150
$M_{z,max.}$ [Nm]	132	228	680	1150

Note

For a guide system to have a service life of 5000 km, the load comparison factor must have a value of $f_v \leq 1$, based on the maximum permissible forces and torques for a service life of 5000 km.

If the axis is subjected to two or more of the indicated forces and torques simultaneously, the following equation must be satisfied in addition to the indicated maximum loads:

Calculating the load comparison factor:

$$f_v = \frac{|F_{y1}|}{F_{y2}} + \frac{|F_{z1}|}{F_{z2}} + \frac{|M_{x1}|}{M_{x2}} + \frac{|M_{y1}|}{M_{y2}} + \frac{|M_{z1}|}{M_{z2}} \leq 1$$

F_1/M_1 = dynamic value

F_2/M_2 = maximum value

Data sheet

Calculating the service life

The service life of the guide depends on the load. To be able to make a statement as to the service life of the guide, the graph below plots the load comparison factor f_v against the service life.

These values are only theoretical. You must consult your local Festo contact for a load comparison factor f_v greater than 1.5.

Load comparison factor f_v as a function of service life

Example:

A user wants to move an X kg load. Using the formula (→ page 16) gives a value of 1.5 for the load comparison factor f_v . According to the graph, the guide would have a service life of approx. 1500 km. Reducing the acceleration reduces the M_z and M_y values. A load comparison factor f_v of 1 now gives a service life of 5000 km.

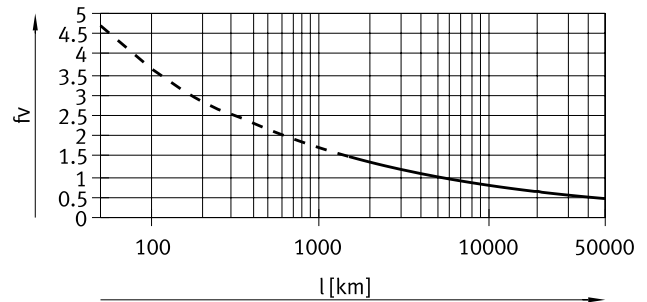

Note

Engineering software
PositioningDrives
www.festo.com

The software can be used to calculate a guide workload for a service life of 5000 km.

$f_v > 1.5$ are only theoretical comparison values for the recirculating ball bearing guide.

Comparison of the characteristic load values for 5000 km with dynamic forces and torques of recirculating ball bearing guides

The characteristic load values of bearing guides are standardised to ISO and JIS using dynamic and static forces and torques. These forces and torques are based on an expected service life of the guide system of 100 km according to ISO or 50 km according to JIS.

As the characteristic load values are dependent on the service life, the maximum permissible forces and torques for a 5000 km service life cannot be compared with the dynamic forces and torques of bearing guides to ISO/JIS.

To make it easier to compare the guide capacity of linear axes ELGA with bearing guides, the table below lists the theoretically permissible forces and torques for a calculated service life of 100 km. This corresponds to the dynamic forces and torques to ISO.

These 100 km values have been calculated mathematically and are only to be used for comparing with dynamic forces and torques to ISO. The drives must not be loaded with these characteristic values as this could damage the axes.

Max. permissible forces and torques for a theoretical service life of 100 km (from a guide perspective only)

Size		70	80	120	150
$F_{y_{max}}$	[N]	5520	9200	20240	40480
$F_{z_{max}}$	[N]	6808	11224	25355	40480
$M_{x_{max}}$	[Nm]	59	132	383	615
$M_{y_{max}}$	[Nm]	486	839	2502	4232
$M_{z_{max}}$	[Nm]	486	839	2502	4232

Data sheet

Max. acceleration a as a function of payload m

Size 70

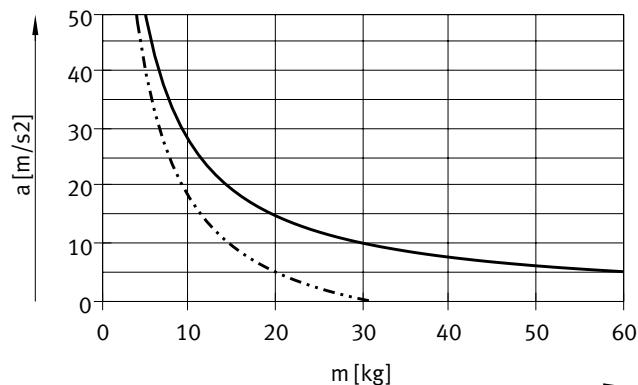

Size 80

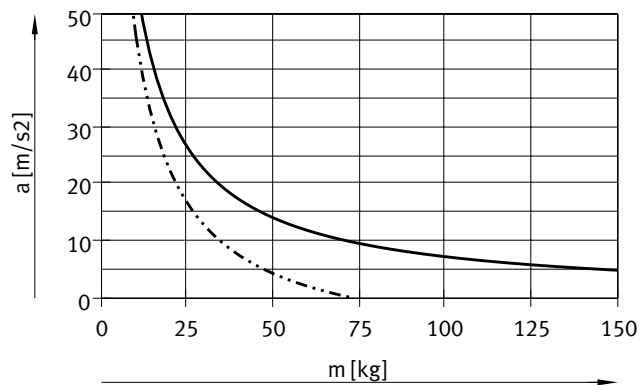

Size 120

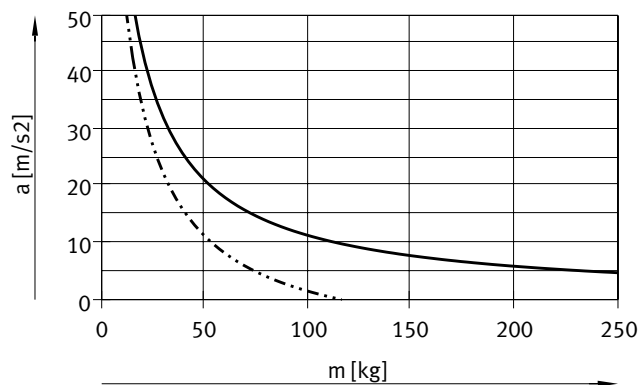

Size 150

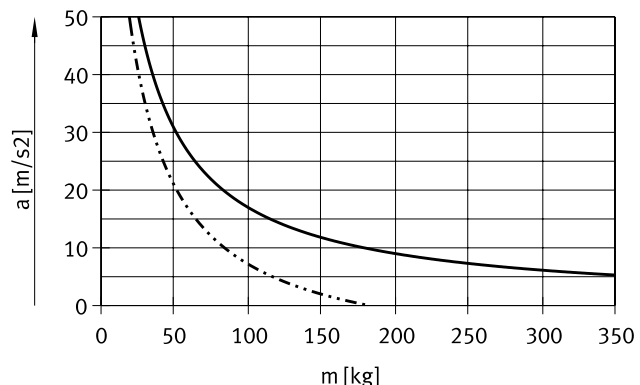

— Horizontal mounting position
 - - - Vertical mounting position

Speed v as a function of rotational speed n

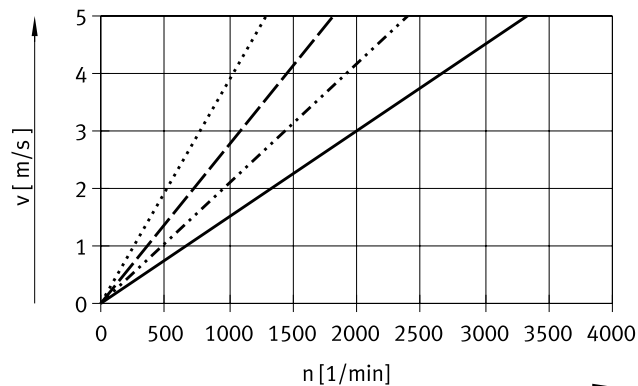

— ELGA-TB-KF-70
 ELGA-TB-KF-80
 - - - ELGA-TB-KF-120
 - · - · ELGA-TB-KF-150

Data sheet

Theoretical feed force F as a function of input torque M

Size 70

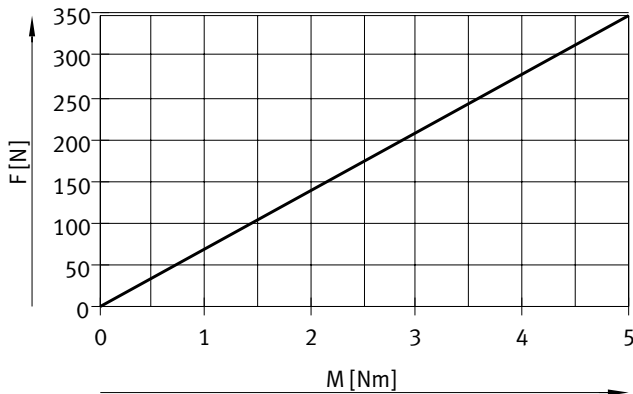

ELGA-TB-KF-70

Size 80/120/150

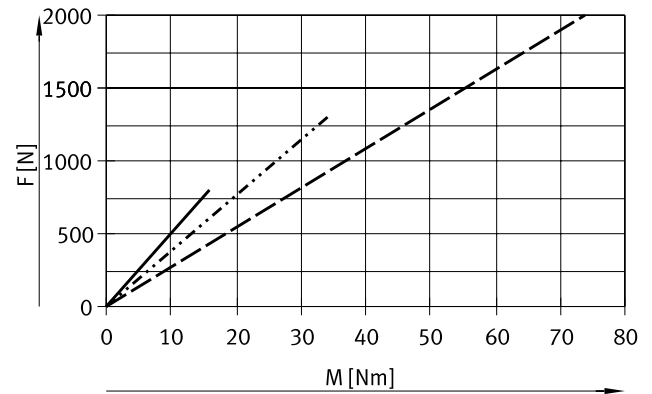

ELGA-TB-KF-80
 ELGA-TB-KF-120
 ELGA-TB-KF-150

Stroke reserve

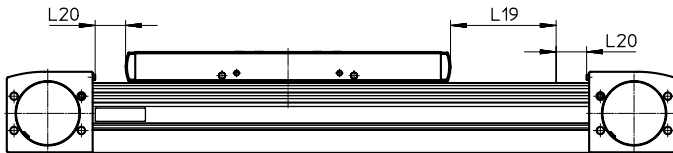

L19 = Nominal stroke
 L20 = Stroke reserve

- The stroke reserve is a safety distance from the mechanical end position and is not used in normal operation
 - The sum of the nominal stroke and 2x stroke reserve must not exceed the maximum permissible working stroke
 - The stroke reserve length can be freely selected
 - The stroke reserve is defined via the "stroke reserve" characteristic in the modular product system.
- Example:**
 Type ELGA-TB-KF-70-500-20H-...
 Nominal stroke = 500 mm
 2x stroke reserve = 40 mm
 Working stroke = 540 mm
 (540 mm = 500 mm + 2x 20 mm)

Working stroke reduction

For axis ELGA with additional slide ZL/ZR

For a toothed belt axis with additional slide, the working stroke is reduced by the length of the additional slide and the distance between the two slides

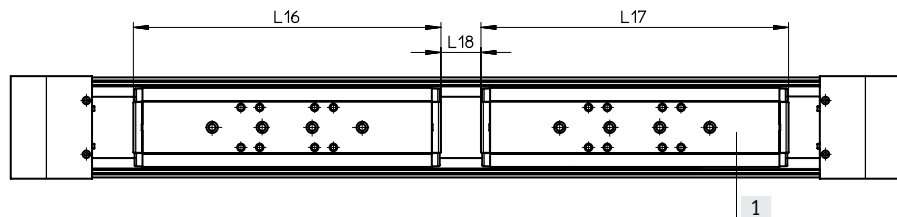

L16 = Slide length
 L17 = Additional slide length
 L18 = Distance between the two slides
 [1] Additional slide

Example:
 Type ELGA-TB-KF-70-500-...-ZR
 Working stroke without additional slide = 500 mm
 L18 = 50 mm
 L16, L17 = 221 mm
 Working stroke with additional slide = 229 mm
 (500 mm - 50 mm - 221 mm)

Dimensions – Additional slide

Size	70	80	120	150
Length L17 [mm]	221	246	335	378.4
Min. distance between the slides L18 [mm]	≥ 50	≥ 50	≥ 50	≥ 50

Data sheet

Second moment of area

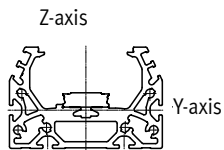

Size		70	80	120	150
I_y	[mm ⁴]	1.46×10^5	2.57×10^5	1.26×10^6	4.62×10^6
I_z	[mm ⁴]	4.59×10^5	9.14×10^5	4.37×10^6	12.32×10^6

Maximum permissible support spacing L (without profile mounting MUE/central support EAHF) as a function of force F

In order to limit deflection in the case of large strokes, the axis may need to be supported.

The following graphs can be used to determine the maximum permissible support spacing L as a function of force F acting on the axis. The deflection is $f = 0.5$ mm.

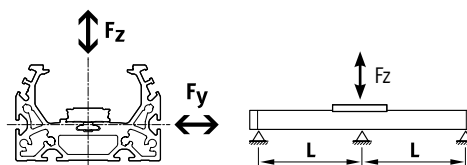

Force F_y

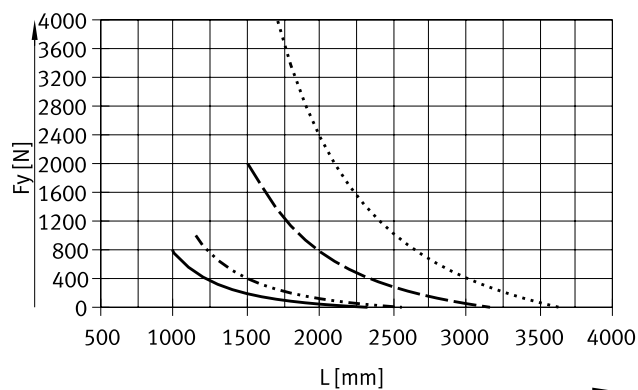

- ELGA-TB-KF-70
- ELGA-TB-KF-80
- - - ELGA-TB-KF-120
- · - · ELGA-TB-KF-150

Force F_z

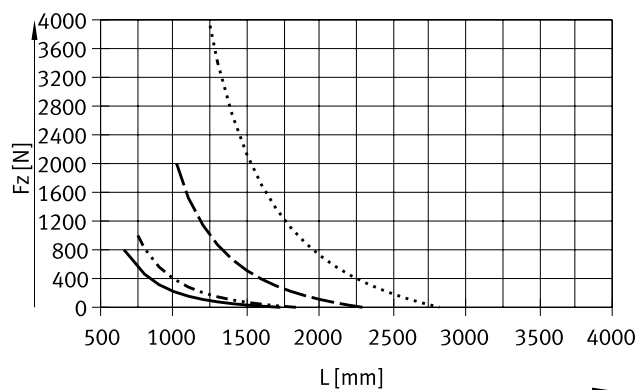

Recommended deflection limits

Adherence to the following deflection limits is recommended so as not to impair the functionality of the axes.

Greater deformation can result in increased friction, greater wear and reduced service life.

Size	Dynamic deflection (moving load)	Static deflection (stationary load)
70 ... 150	0.05% of the axis length, max. 0.5 mm	0.1% of the axis length

Data sheet

Central lubrication

The lubrication connections enable the guide of the toothed belt axis ELGA-TB-KF to be permanently lubricated in applications in humid or wet ambient conditions using semi- or fully automatic relubrication devices.

- The connection options are already available in the standard design of the axes
- There is a dedicated lubrication connection for the spindle nut and the two ball cassettes

Slide dimensions
→ page 24

Structure of a central lubrication system

A central lubrication system requires various additional components. The illustration shows different options (using a hand pump, pneumatic container pump or electric container pump) required as a minimum for designing a central lubrication system. Festo does not sell these additional components; however, they can be obtained from the following companies:

- Lincoln
- Bielomatik
- SKF (Vogel)

Festo recommends these companies because they can supply all the necessary components.

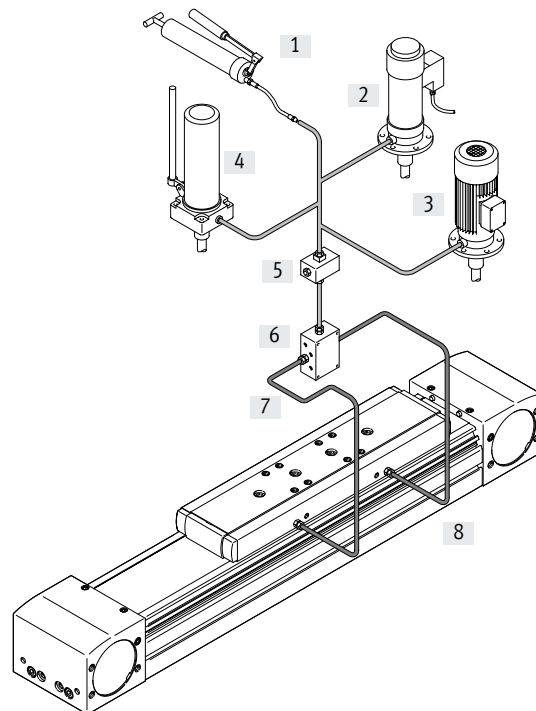

- [1] Hand pump
- [2] Pneumatic container pump
- [3] Electric container pump
- [4] Manually operated container pump
- [5] Nipple block
- [6] Distributor block
- [7] Tubing or piping
- [8] Fittings

Data sheet

Dimensions

Download CAD data → www.festo.com

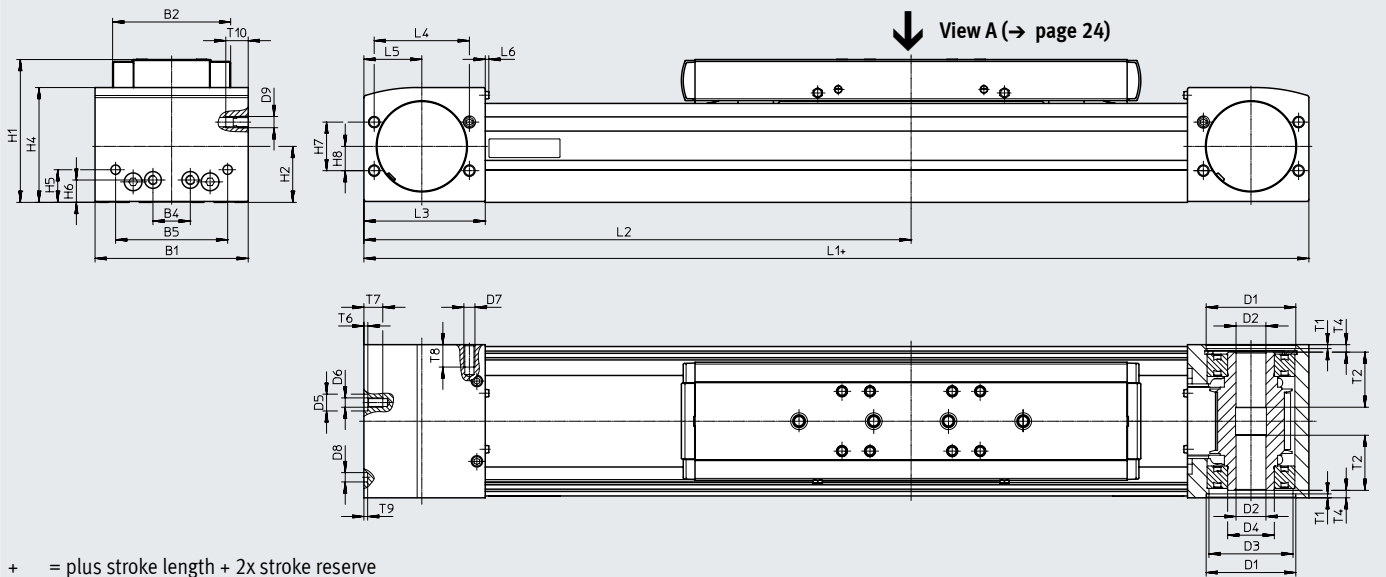

Size	B1	B2	B4	B5	D1 ∅ H7	D2 ∅ H7	D3 ∅	D4 ∅	D5 ∅ H7	D6	D7
70	69	48.2	30	45	38	16	34	25	–	M5	M6
80	82	63.2	20	60	48	16	45	25	9	M5	M6
120	120	95	80	40	80	23	72	45	–	M8	M8
150	154	125	115	80	95	32	90	60	–	M8	M8

Size	D8 ∅ H7	D9	H1	H2	H4	H5	H6	H7	H8	L1	L2 min.
70	5	M6	64	26.5	50.8	13	13	24	12	346	173
80	5	M6	76.5	30	61.5	17.5	12	26	13	386	193
120	9	M8	111.5	45	91	22	22	59	32	546	273
150	9	M8	141.5	58.6	121	26.5	26.5	80	40	712	356

Size	L3	L4	L5	L6	T1	T2	T4	T6	T7	T8	T9	T10
70	57.5	42	27.5	2.3	2.1	18	7.2	–	10	12	3.1	12
80	65	51	31	2.3	2.1	29.5	4	2.1	10.1	12	2	12
120	100	76	50	2.5	3.1	29.5	4	–	16	16	2.1	16
150	140	80	70	2.5	2.8	32	4	–	18	17	2.1	17

Data sheet

Dimensions

Download CAD data → www.festo.com

Profile

Size 70

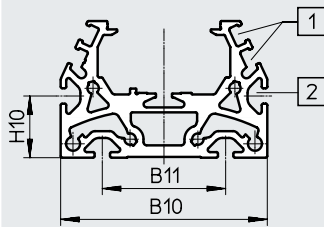

Size 80

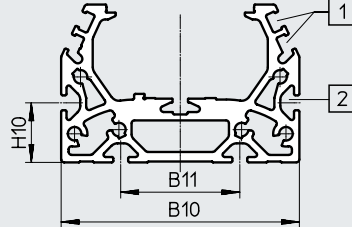

Size 120

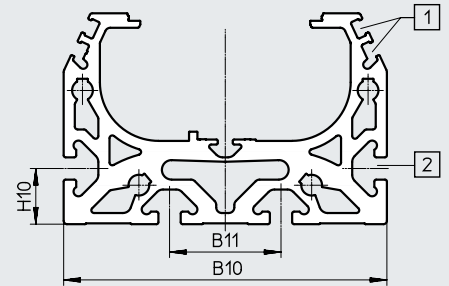

Size 150

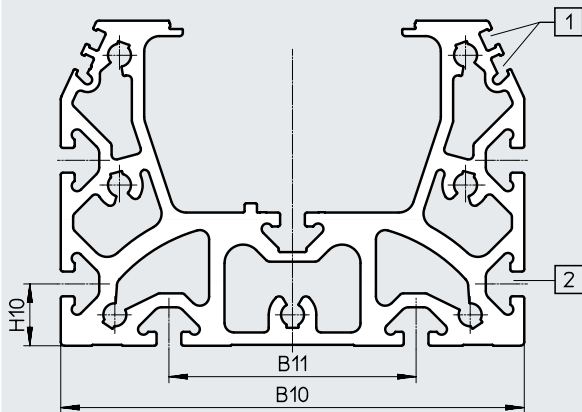

- [1] Sensor slot for proximity switch
- [2] Mounting slot for slot nut:
for size 70, 80: slot nut NST-5-M5
for size 120, 150: slot nut NST-8-M6

- **Note**

Requirements for the flatness of the bearing surface and of attachments as well as for use in parallel structures

→ www.festo.com/sp User documentation.

Size	B10	B11	H10
70	67	40	20
80	80	40	20
120	116	40	20
150	150	80	20

Data sheet

Dimensions

Download CAD data → www.festo.com

Slide

Size 70

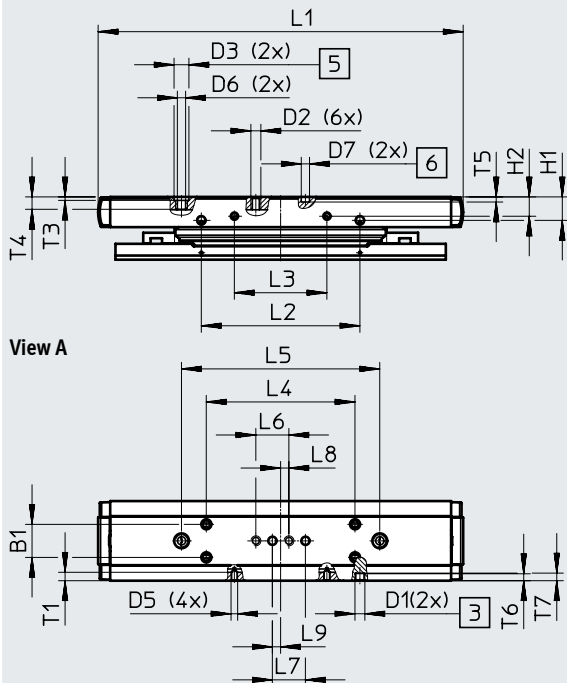

Size 80

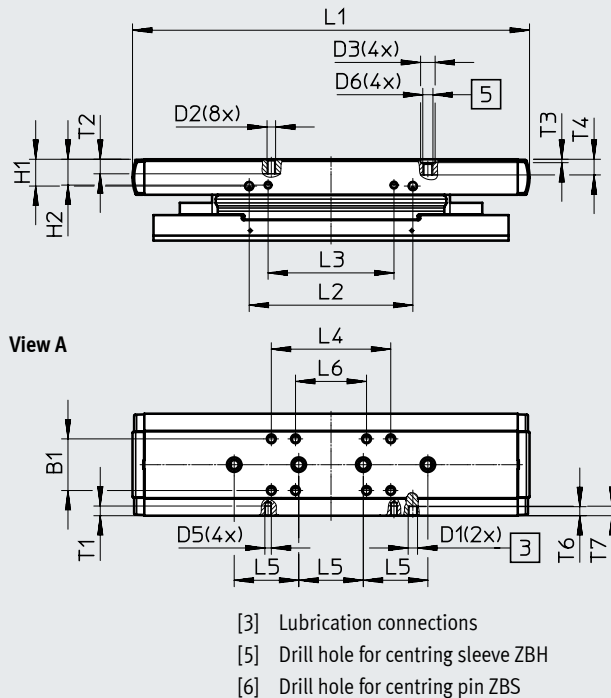

- [3] Lubrication connections
- [5] Drill hole for centring sleeve ZBH
- [6] Drill hole for centring pin ZBS

Size	B1	D1	D2	D3 ∅ H7	D5	D6	D7 ∅ H7	H1	H2	L1	L2	L3
	±0.1							±0.1	±0.1		±0.1	±0.1
70	20	M6	M5	9	M4	M6	5	14.2	11.7	221	96	56
80	32	M6	M5	9	M4	M6	-	16.6	16	246	101.4	78

Size	L4	L5	L6	L7	L8	L9	T1	T2	T3	T4	T5	T6	T7
	±0.1	±0.03	±0.1	±0.03		±0.1			+0.1		±0.1	min.	max.
70	90	120	20	20	5	10	5.1	-	2.1	7.5	3.1	4.2	4.6 _{-0.1}
80	74	40	44	-	-	-	6	9	2.1	9.7 _{-0.2}	-	5.6	5.9 _{-0.1}

Data sheet

Dimensions

Download CAD data → www.festo.com

Slide

Size 120

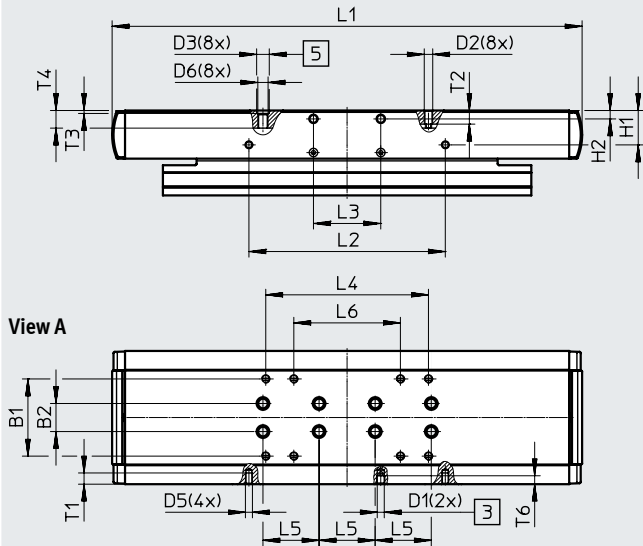

Size 150

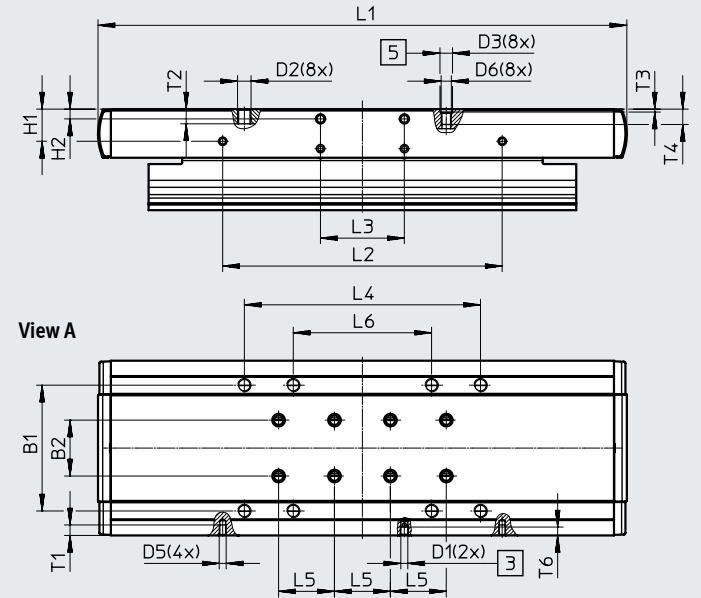

- [3] Lubrication connections
- [5] Drill hole for centring sleeve ZBH

Size	B1	B2	D1	D2	D3 ∅ H7	D5	D6	H1	H2	L1
	±0.2	±0.03						±0.1		
120	55	20	M6	M5	9	M5	M6	24.5	6	335
150	90	40	M6	M8	9	M5	M6	23	7±0.1	378.4

Size	L2	L3	L4	L5	L6	T1	T2	T3	T4	T6
	±0.1	±0.1	±0.2	±0.03	±0.2			+0.1		
120	140	48	116	40	76	8	9.7	2.1	12.6 _{-0.3}	6
150	200	60	169	40	99	7.5	10.7	2.1	11	7

Data sheet

Dimensions

Download CAD data → www.festo.com

ELGA...-M1/M2 – With incremental displacement encoder

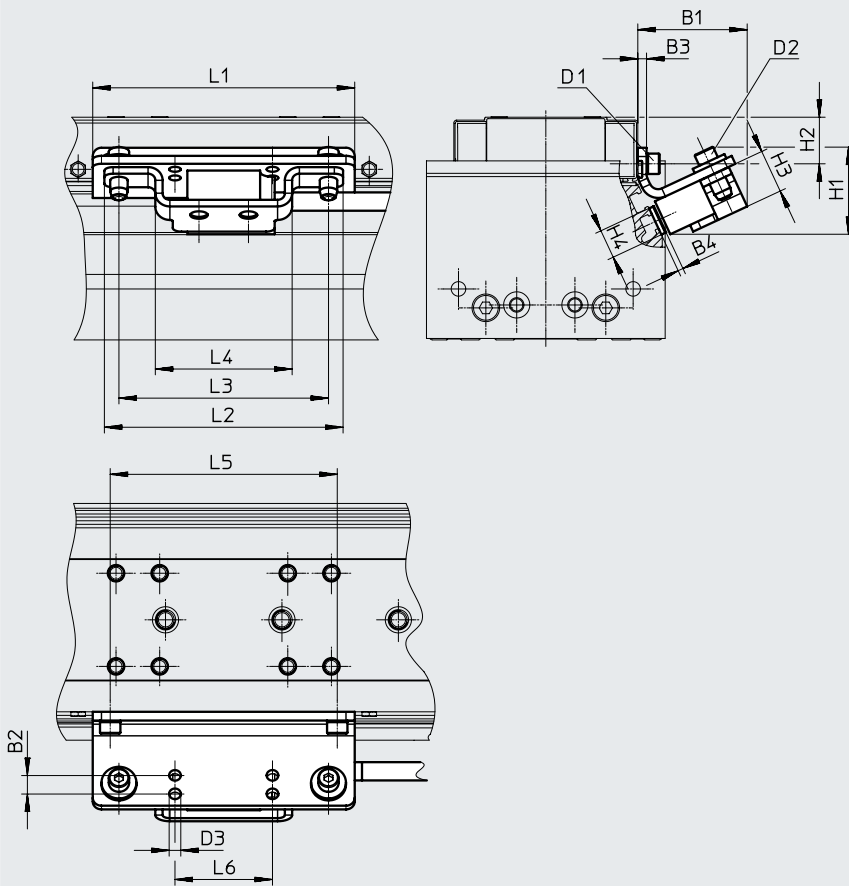

Encoder cable
(connection to motor controller/
safety system)
→ Page 110

Size	B1	B2	B3	B4	D1	D2	D3 ∅	H1	H2
70	40	7	3	1.8	M4x8	M4x14	4	35	11.7
80	40	7	3	1.8	M4x14	M4x14	4	35	16
120	41	7	3	1.8	M4x14	M4x14	4	35	24.5
150	42	7	3	1.8	M5x10	M4x14	4	35	23

Size	H3	H4	L1	L2	L3	L4	L5	L6
70	15	10	86	82	72	47	56	33.5
80	15	10	90	82	72	47	78	33.5
120	15	10	170	82	72	47	140	33.5
150	15	10	220	82	72	47	200	33.5

Data sheet

Ordering data

Key features:

- Stroke reserve: 0 mm
- Standard slide

Size	Stroke [mm]	Part no.	Type
70	300	★ 8041851	ELGA-TB-KF-70-300-0H
	400	★ 8041852	ELGA-TB-KF-70-400-0H
	500	★ 8041853	ELGA-TB-KF-70-500-0H
	600	★ 8041854	ELGA-TB-KF-70-600-0H
	800	★ 8041855	ELGA-TB-KF-70-800-0H
	1000	★ 8041856	ELGA-TB-KF-70-1000-0H
	1200	★ 8041857	ELGA-TB-KF-70-1200-0H
80	400	★ 8041858	ELGA-TB-KF-80-400-0H
	500	★ 8041859	ELGA-TB-KF-80-500-0H
	600	★ 8041860	ELGA-TB-KF-80-600-0H
	800	★ 8041861	ELGA-TB-KF-80-800-0H
	1000	★ 8041862	ELGA-TB-KF-80-1000-0H
	1200	★ 8041863	ELGA-TB-KF-80-1200-0H
120	400	★ 8041864	ELGA-TB-KF-120-400-0H
	500	★ 8041865	ELGA-TB-KF-120-500-0H
	600	★ 8041866	ELGA-TB-KF-120-600-0H
	800	★ 8041867	ELGA-TB-KF-120-800-0H
	1000	★ 8041868	ELGA-TB-KF-120-1000-0H
	1200	★ 8041869	ELGA-TB-KF-120-1200-0H
	1500	★ 8041870	ELGA-TB-KF-120-1500-0H

Festo core product range



Generally ready for dispatch from the factory within 24 hours

Generally ready for dispatch from the factory within 5 days

Ordering data – Modular product system

Orientation guide

- O top
- U bottom
- R right
- L left
- V front
- H rear

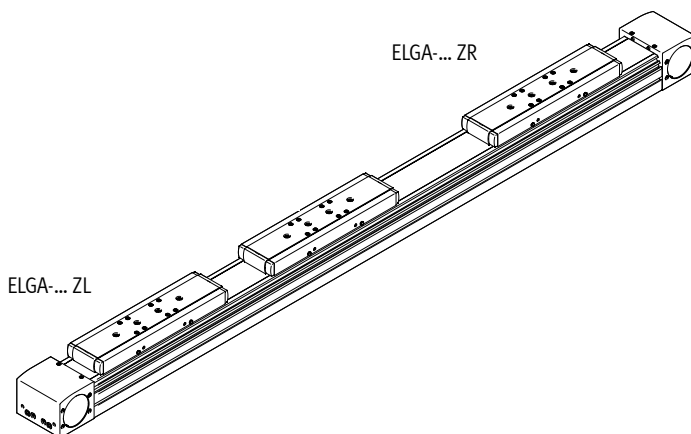
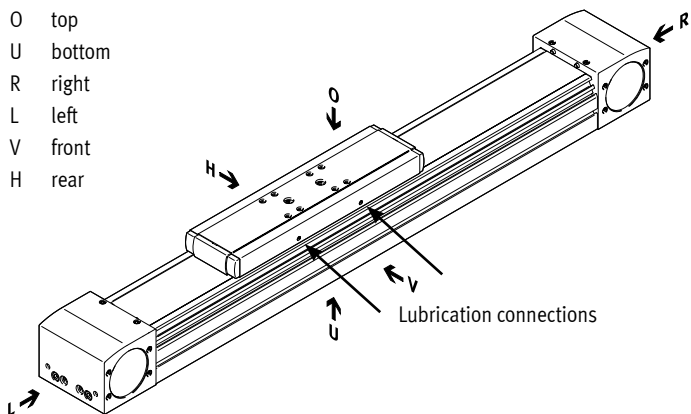

Accessories

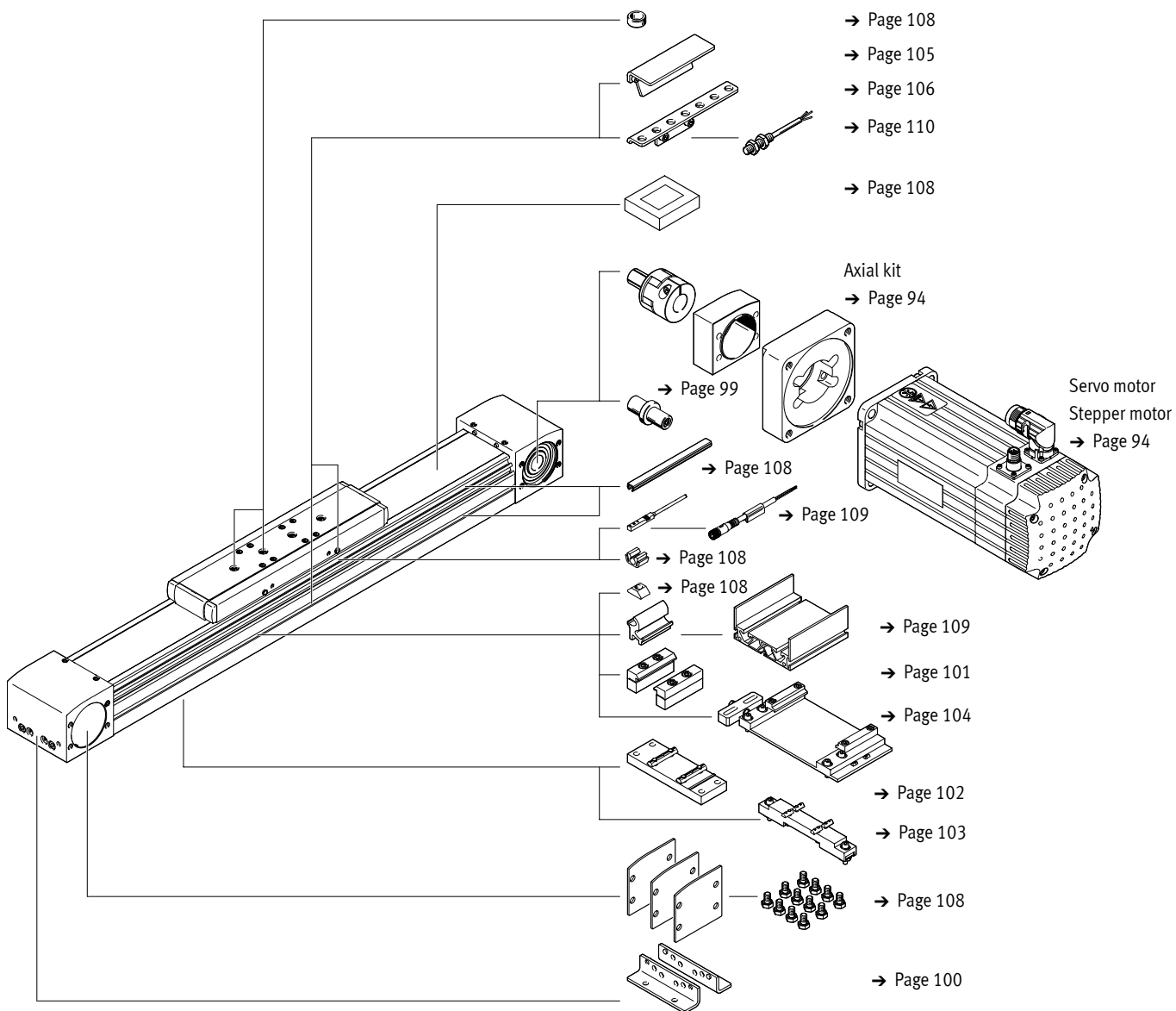

Ordering data – Modular product system

Ordering table							
Size	70	80	120	150	Conditions	Code	Enter code
Module no.	8024914	8024915	8024916	8024917			
Design	Linear axis					★ ELGA	ELGA
Function	Toothed belt					★ -TB	-TB
Guide	Recirculating ball bearing guide					★ -KF	-KF
Size [mm]	70	80	120	150		★ -...	
Stroke length [mm]	1 ... 5000	1 ... 8500	1 ... 8500	1 ... 7000		★ -...	
Stroke reserve [mm]	0 ... 999 (0 = no stroke reserve)				[1]	★ -...H	
Additional slide	None					★	
	1 slide left					★ -ZL	
	1 slide right					★ -ZR	
Displacement encoder, incremental	None					★	
	Resolution 2.5 µm					-M1	
	Resolution 10 µm					-M2	
Displacement encoder attachment position	None					★	
	Rear				[2]	B	
	Front				[2]	F	
Material of toothed belt	Chloroprene rubber						
	Coated PU					-PU2	
Operating instructions	With operating instructions					★	
	Without operating instructions					★ -DN	

[1] ... H The sum of the nominal stroke and 2x stroke reserve must be at least 50 mm and must not exceed the maximum stroke length

[2] B, F Only with displacement encoder M1, M2

Festo core product range



Generally ready for dispatch from the factory within 24 hours

Generally ready for dispatch from the factory within 5 days

Peripherals overview – For the food zone

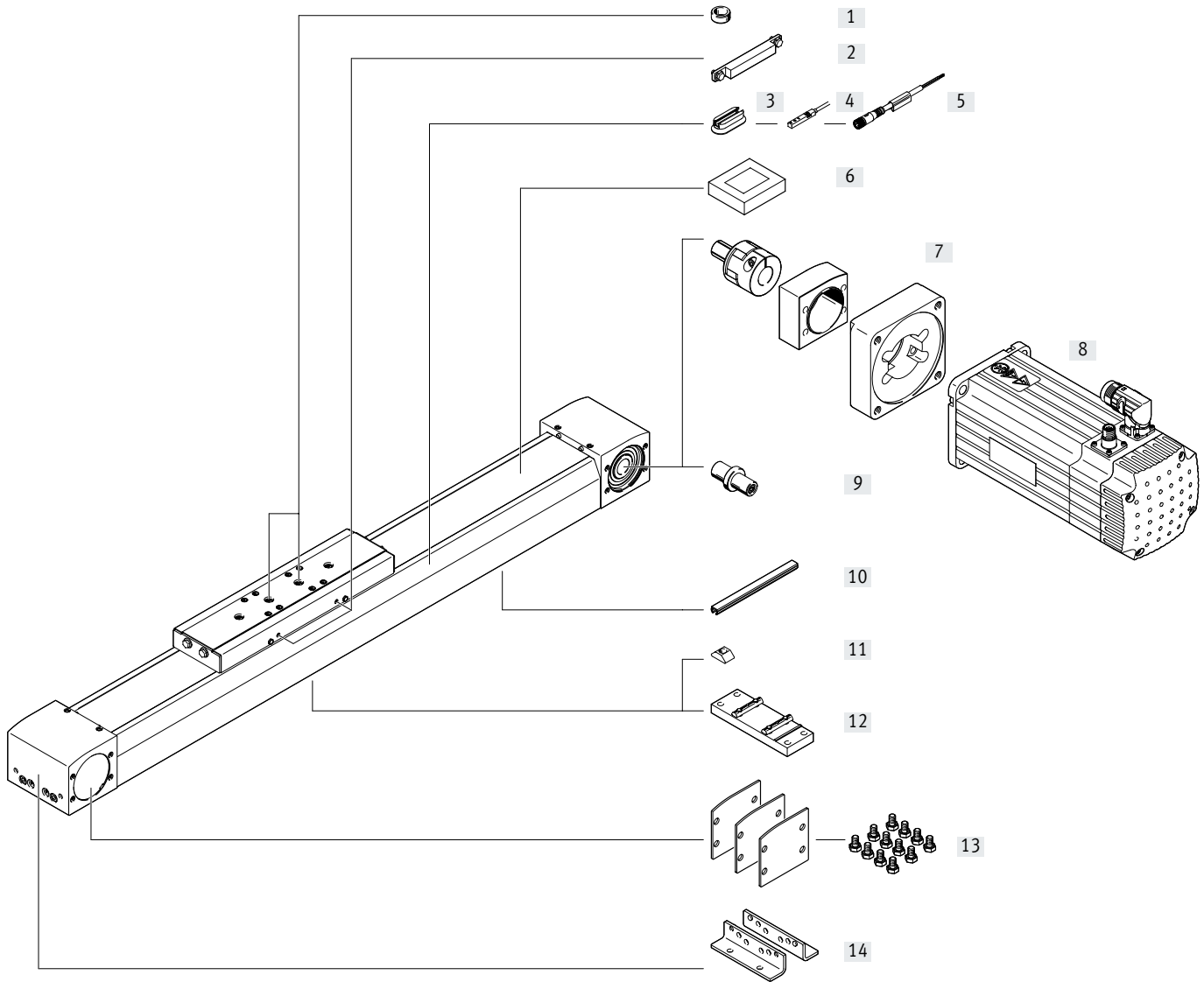
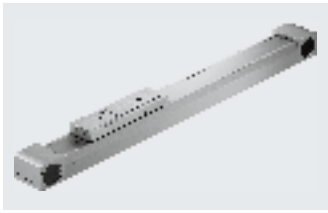



Peripherals overview – For the food zone

Accessories			
Type	Description		→ Page/Internet
[1] Centring pin/sleeve ZBS, ZBH	<ul style="list-style-type: none"> For centring loads and attachments on the slide Included in the scope of delivery: <ul style="list-style-type: none"> For size 70: 2x ZBS-5 For size 80, 120, 150: 2x ZBH-9 		108
[2] Switch lug EAPM	For sensing the slide position		107
[3] Mounting kit CRSMB	For mounting the inductive proximity switches (round design) on the axis		107
[4] Proximity switch, T-slot SME-8M	For sensing the slide position		110
[5] Connecting cable NEBU	For proximity switch		110
[6] Clamping element EADT	Tool for retensioning the cover strip		108
[7] Axial kit EAMM	For axial motor mounting (comprises: coupling, coupling housing and motor flange)		94
[8] Motor EMME, EMMS	Motors specially matched to the axis, with or without gear unit, with or without brake		94
[9] Drive shaft EAMB	<ul style="list-style-type: none"> Can, if required, be used as an alternative interface No drive shaft is required for the axis/motor combinations → page 100 		99
[10] Slot cover ABP	For protection against contamination		108
[11] Slot nut NST	For mounting attachments		108
[12] Central support EAHF-L5	For mounting the axis on the profile from underneath		102
[13] Cover kit EASC-L5	For covering the sides of the drive cover		108
[14] Foot mounting HPE	<ul style="list-style-type: none"> For mounting the axis on the end cap With higher forces and torques, the axis should be mounted using the profile 		100

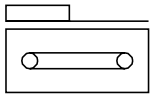
Data sheet – For the food zone



-  - Size
70 ... 120
-  - Stroke length
50 ... 8500 mm
-  - www.festo.com

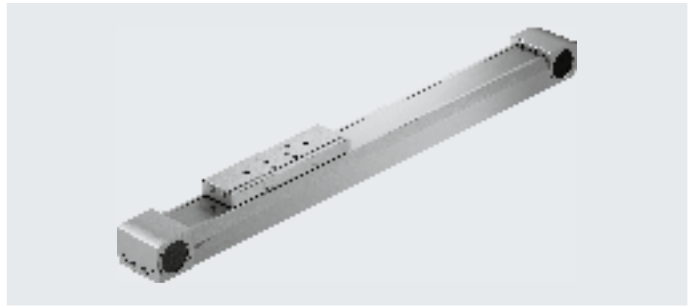

General technical data		70	80	120
Size		70	80	120
Design		Electromechanical axis with toothed belt		
Guide		Recirculating ball bearing guide		
Mounting position		Any		
Working stroke	[mm]	50 ... 5000	50 ... 8500	50 ... 8500
Max. feed force F_x	[N]	260	600	1000
Max. no-load torque ¹⁾	[Nm]	0.8	1.5	4.5
Max. no-load resistance to shifting ¹⁾	[N]	55.8	75.4	122
Max. driving torque	[Nm]	3.72	11.9	26.2
Max. speed	[m/s]	5		
Max. acceleration	[m/s ²]	50		
Repetition accuracy	[mm]	±0.08		

1) At 0.2 m/s

Operating and environmental conditions		
Ambient temperature ¹⁾	[°C]	-10 ... +60
Degree of protection		IP40
Duty cycle	[%]	100
Food-safe ²⁾		→ Supplementary material information

1) Note operating range of proximity switches.

2) Additional information www.festo.com/sp → Certificates.

Weight [kg]		70	80	120
Size		70	80	120
Basic weight with 0 mm stroke ¹⁾		3.01	4.70	15.68
Additional weight per 1000 mm stroke		4.00	5.13	10.64
Moving mass				
ELGA-...		0.9	1.9	4.19
ELGA-...ZL/ZR		0.74	1.53	3.24

1) Incl. slide

Data sheet – For the food zone

Toothed belt				
Size		70	80	120
Pitch	[mm]	3	5	5
Elongation ¹⁾	[%]	0.105	0.1	0.122
Effective diameter	[mm]	28.65	39.79	52.52
Feed constant	[mm/rev]	90	125	165

1) At max. feed force

Mass moment of inertia				
Size		70	80	120
J_0	[kg mm ²]	245	976	4065
J_H per metre stroke	[kg mm ² /m]	24.4	76.8	176.5
J_L per kg payload	[kg mm ² /kg]	205	396	690
J_W for additional slide	[kg mm ²]	186	761	2891

The mass moment of inertia J_A of the entire axis is calculated as follows:

$$J_A = J_0 + K \times J_W + J_H \times \text{working stroke [m]} + J_L \times m_{\text{payload [kg]}}$$

K = Number of additional slides

Materials

Sectional view

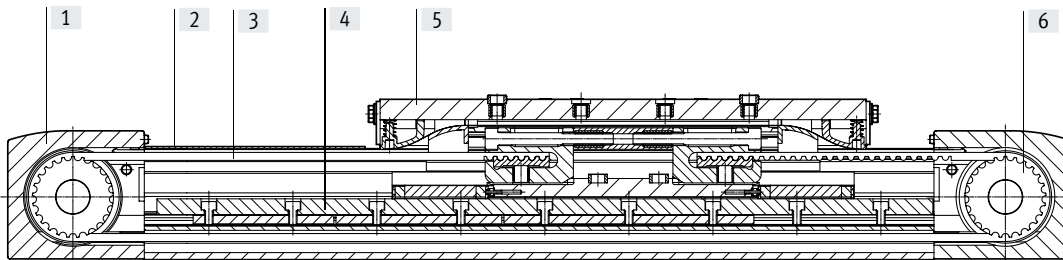

Axis		70	80	120
[1] Drive cover		Anodised wrought aluminium alloy		
[2] Cover strip		Stainless steel strip, non-corroding		
[3] Toothed belt		Polyurethane with steel cord		
[4] Guide rail		Stainless steel		Tempered steel
[5] Slide		Anodised wrought aluminium alloy		
[6] Belt pulley		High-alloy stainless steel		
Note on materials		RoHS-compliant		
		Contains paint-wetting impairment substances		

Data sheet – For the food zone

Characteristic load values

The indicated forces and torques refer to the centre of the guide. The point of application of force is the point where the centre of the guide and the longitudinal centre of the slide intersect. These values must not be exceeded during dynamic operation. Special attention must be paid to the cushioning phase.

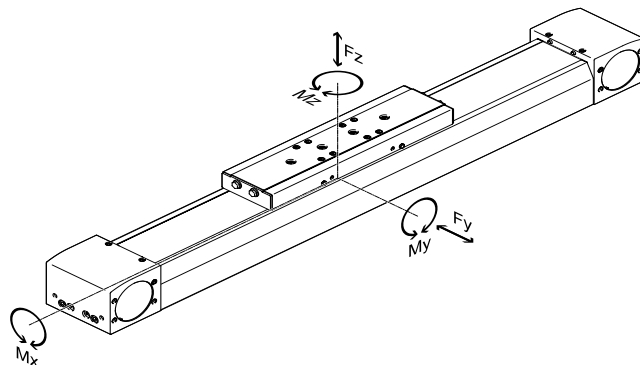

Distance from the slide surface to the centre of the guide

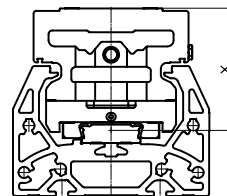

Distance from the slide surface to the centre of the guide

Size		70	80	120
Dimension x	[mm]	37	50	70

Max. permissible forces and torques for a service life of 5000 km

Size		70	80	120
$F_{y_{max}}$	[N]	1500	2500	5500
$F_{z_{max}}$	[N]	1850	3050	6890
$M_{x_{max}}$	[Nm]	16	36	104
$M_{y_{max}}$	[Nm]	132	228	680
$M_{z_{max}}$	[Nm]	132	228	680

Note

For a guide system to have a service life of 5000 km, the load comparison factor must have a value of $f_v \leq 1$, based on the maximum permissible forces and torques for a service life of 5000 km.

If the axis is subjected to two or more of the indicated forces and torques simultaneously, the following equation must be satisfied in addition to the indicated maximum loads:

Calculating the load comparison factor:

$$f_v = \frac{|F_{y1}|}{F_{y2}} + \frac{|F_{z1}|}{F_{z2}} + \frac{|M_{x1}|}{M_{x2}} + \frac{|M_{y1}|}{M_{y2}} + \frac{|M_{z1}|}{M_{z2}} \leq 1$$

F_1/M_1 = dynamic value

F_2/M_2 = maximum value

Data sheet – For the food zone

Calculating the service life

The service life of the guide depends on the load. To be able to make a statement as to the service life of the guide, the graph below plots the load comparison factor f_v against the service life.

These values are only theoretical. You must consult your local Festo contact for a load comparison factor f_v greater than 1.5.

Load comparison factor f_v as a function of service life

Example:

A user wants to move an X kg load. Using the formula (→ page 34) gives a value of 1.5 for the load comparison factor f_v . According to the graph, the guide would have a service life of approx. 1500 km. Reducing the acceleration reduces the M_z and M_y values. A load comparison factor f_v of 1 now gives a service life of 5000 km.

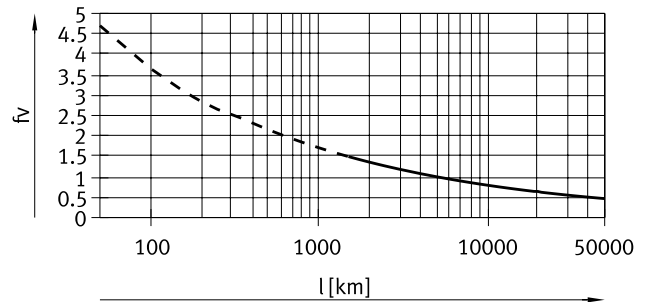

Note

Engineering software
PositioningDrives
www.festo.com

The software can be used to calculate a guide workload for a service life of 5000 km.

$f_v > 1.5$ are only theoretical comparison values for the recirculating ball bearing guide.

Comparison of the characteristic load values for 5000 km with dynamic forces and torques of recirculating ball bearing guides

The characteristic load values of bearing guides are standardised to ISO and JIS using dynamic and static forces and torques. These forces and torques are based on an expected service life of the guide system of 100 km according to ISO or 50 km according to JIS.

As the characteristic load values are dependent on the service life, the maximum permissible forces and torques for a 5000 km service life cannot be compared with the dynamic forces and torques of bearing guides to ISO/JIS.

To make it easier to compare the guide capacity of linear axes ELGA with bearing guides, the table below lists the theoretically permissible forces and torques for a calculated service life of 100 km. This corresponds to the dynamic forces and torques to ISO.

These 100 km values have been calculated mathematically and are only to be used for comparing with dynamic forces and torques to ISO. The drives must not be loaded with these characteristic values as this could damage the axes.

Max. permissible forces and torques for a theoretical service life of 100 km (from a guide perspective only)

Size		70	80	120
$F_{y_{max}}$	[N]	5520	9200	20240
$F_{z_{max}}$	[N]	6808	11224	25355
$M_{x_{max}}$	[Nm]	59	132	383
$M_{y_{max}}$	[Nm]	486	839	2502
$M_{z_{max}}$	[Nm]	486	839	2502

Data sheet – For the food zone

Max. acceleration a as a function of payload m

Size 70

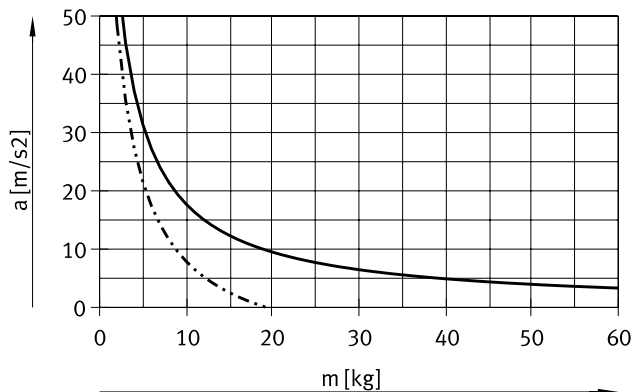

Size 80

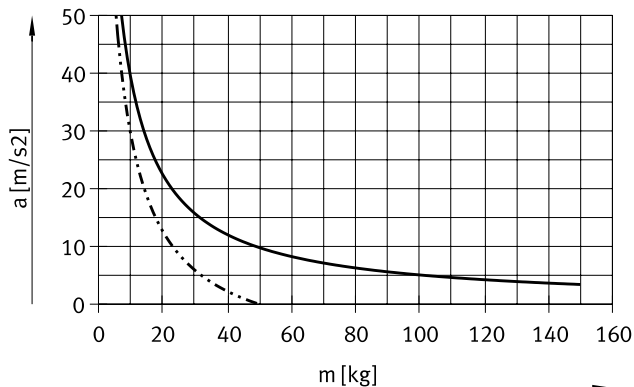

Size 120

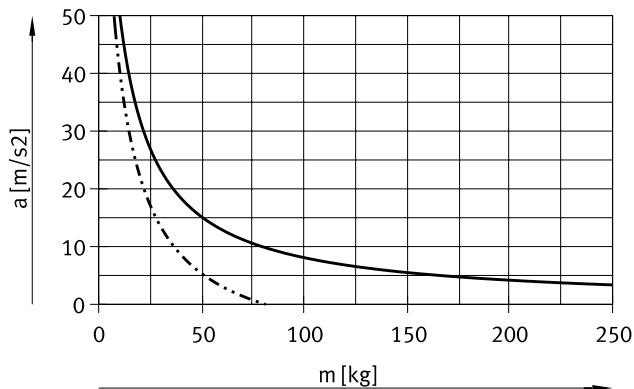

— Horizontal mounting position
 - - - Vertical mounting position

Speed v as a function of rotational speed n

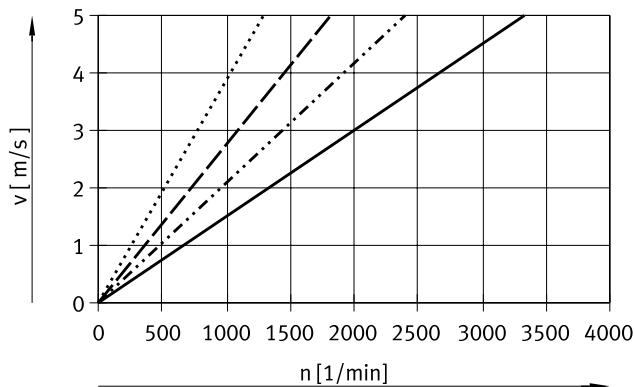

— ELGA-TB-KF-70
 ELGA-TB-KF-80
 - - - ELGA-TB-KF-120

Data sheet – For the food zone

Theoretical feed force F as a function of input torque M

Size 70

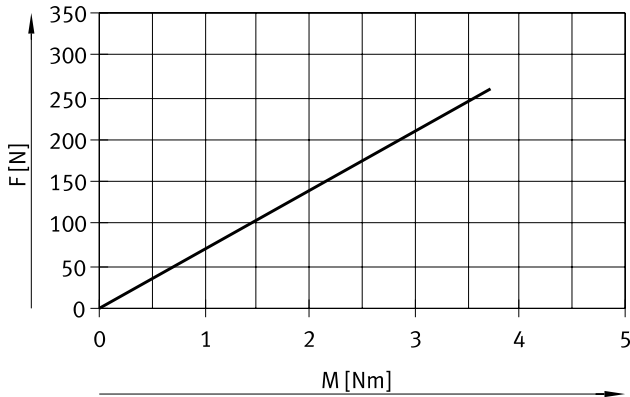

— ELGA-TB-KF-70

Size 80/120

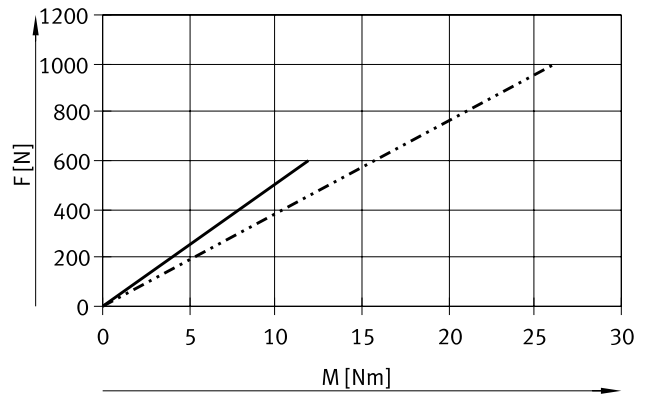

— ELGA-TB-KF-80
- - - - - ELGA-TB-KF-120

Stroke reserve

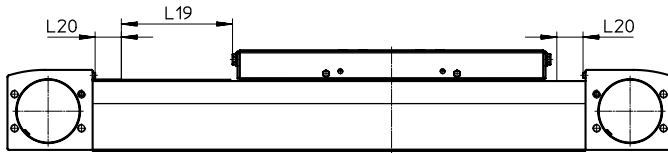

L19 = Nominal stroke
L20 = Stroke reserve

- The stroke reserve is a safety distance from the mechanical end position and is not used in normal operation
- The sum of the nominal stroke and 2x stroke reserve must not exceed the maximum permissible working stroke
- The stroke reserve length can be freely selected
- The stroke reserve is defined via the "stroke reserve" characteristic in the modular product system.

Example:

Type ELGA-TB-KF-70-500-20H-...
Nominal stroke = 500 mm
2x stroke reserve = 40 mm
Working stroke = 540 mm
(540 mm = 500 mm + 2x 20 mm)

Working stroke reduction

For axis ELGA with additional slide ZL/ZR

For a toothed belt axis with additional slide, the working stroke is reduced by the length of the additional slide and the distance between the two slides

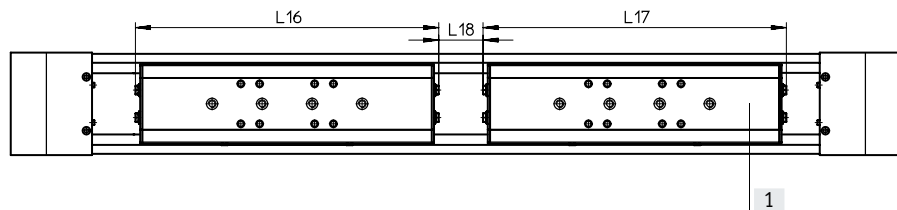

L16 = Slide length
L17 = Additional slide length
L18 = Distance between the two slides
[1] Additional slide

Example:

Type ELGA-TB-KF-70-500-...-ZR
Working stroke without additional slide = 500 mm
L18 = 50 mm
L16, L17 = 221 mm
Working stroke with additional slide = 229 mm
(500 mm – 50 mm – 221 mm)

Dimensions – Additional slide

Size	70	80	120
Length L17 [mm]	221	246	335
Min. distance between the slides L18 [mm]	≥ 50	≥ 50	≥ 50

Data sheet – For the food zone

Second moment of area

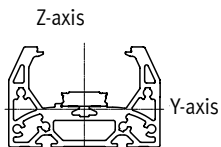

Size		70	80	120
I_y	[mm ⁴]	1.69×10^5	2.95×10^5	1.35×10^6
I_z	[mm ⁴]	4.84×10^5	9.78×10^5	4.50×10^6

Maximum permissible support spacing L (without profile mounting MUE/central support EAHF) as a function of force F

In order to limit deflection in the case of large strokes, the axis may need to be supported.

The following graphs can be used to determine the maximum permissible support spacing L as a function of force F acting on the axis. The deflection is $f = 0.5$ mm.

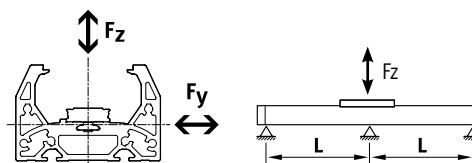

Force F_y

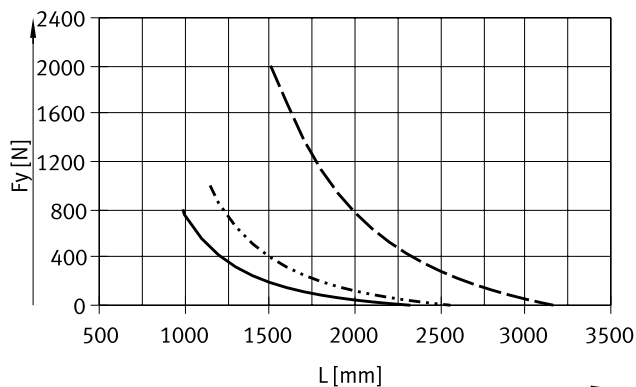

- ELGA-TB-KF-70
- - - ELGA-TB-KF-80
- - - ELGA-TB-KF-120

Force F_z

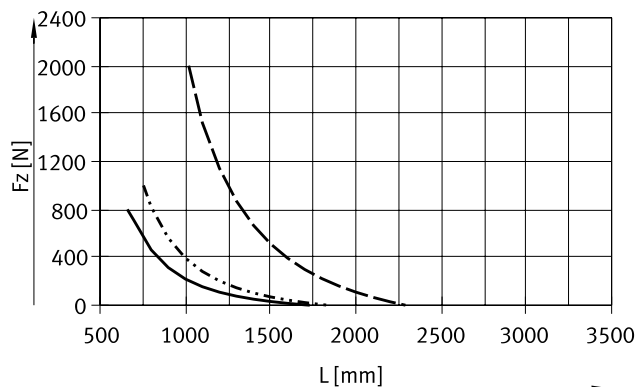

Recommended deflection limits

Adherence to the following deflection limits is recommended so as not to impair the functionality of the axes.

Greater deformation can result in increased friction, greater wear and reduced service life.

Size	Dynamic deflection (moving load)	Static deflection (stationary load)
70 ... 120	0.05% of the axis length, max. 0.5 mm	0.1% of the axis length

Data sheet – For the food zone

Central lubrication

The lubrication connections enable the guide of the toothed belt axis ELGA-TB-KF-F1 to be permanently lubricated in applications in humid or wet ambient conditions using semi- or fully automatic relubrication devices.

- The connection options are already available in the standard design of the axes
- There is a dedicated lubrication connection for the spindle nut and the two ball cassettes

Slide dimensions
→ Page 42

Structure of a central lubrication system

A central lubrication system requires various additional components. The illustration shows different options (using a hand pump, pneumatic container pump or electric container pump) required as a minimum for designing a central lubrication system. Festo does not sell these additional components; however, they can be obtained from the following companies:

- Lincoln
- Bielomatik
- SKF (Vogel)

Festo recommends these companies because they can supply all the necessary components.

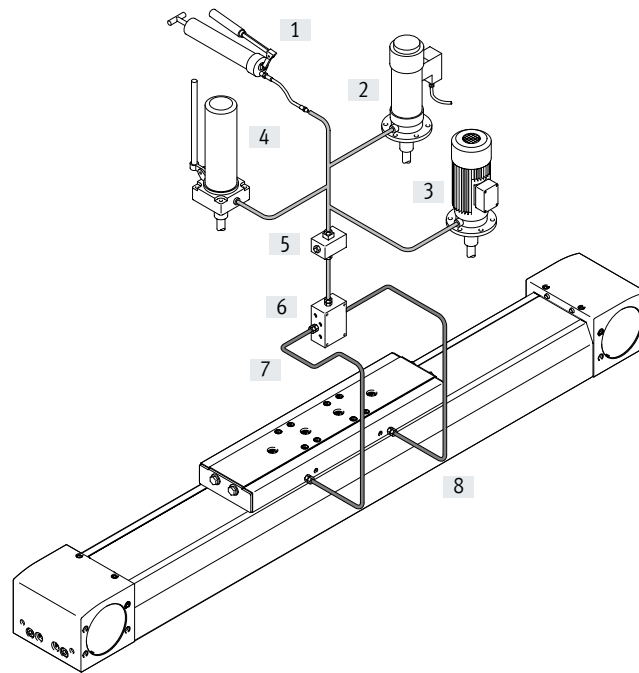

- [1] Hand pump
- [2] Pneumatic container pump
- [3] Electric container pump
- [4] Manually operated container pump
- [5] Nipple block
- [6] Distributor block
- [7] Tubing or piping
- [8] Fittings

Data sheet – For the food zone

Dimensions

Download CAD data → www.festo.com

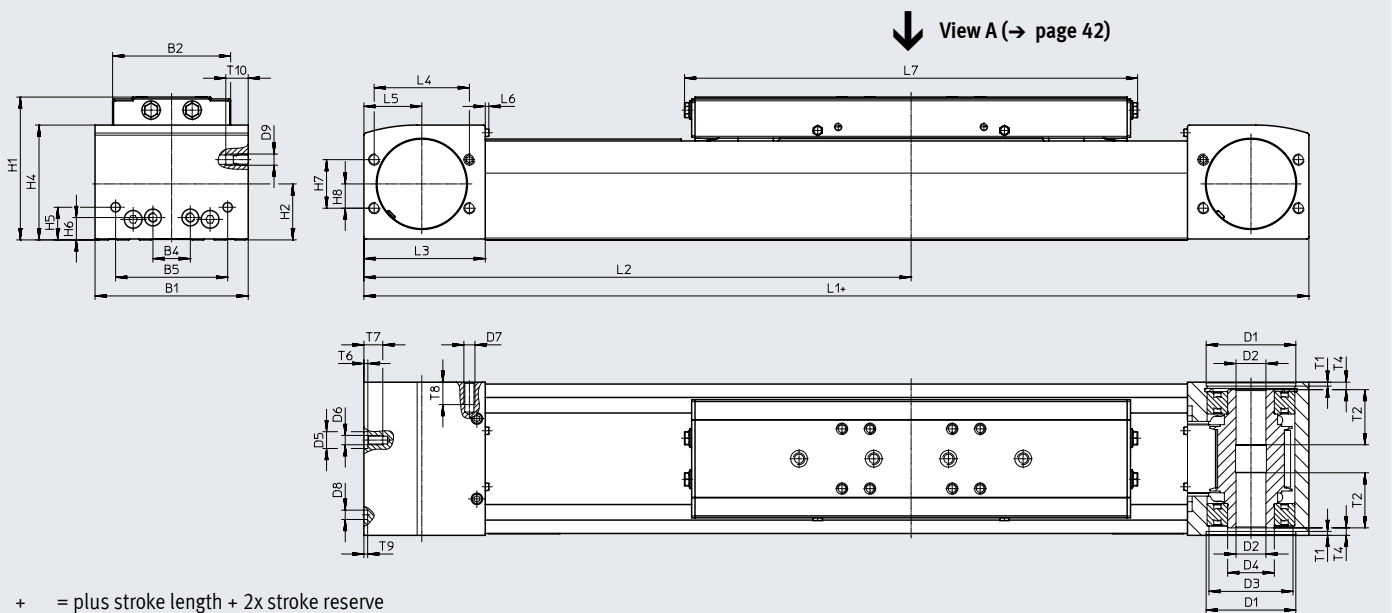

Size	B1	B2	B4	B5	D1 ∅ H7	D2 ∅ H7	D3 ∅	D4 ∅	D5 ∅ H7	D6	D7	D8 ∅ H7
70	69	48.2	30	45	38	16	34	25	–	M5	M6	5
80	82	63.2	20	60	48	16	45	25	9	M5	M6	5
120	120	95	80	40	80	23	72	45	–	M8	M8	9

Size	D9	H1	H2	H4	H5	H6	H7	H8	L1	L2 min.	L3	L4
70	M6	64	26.5	50.8	13	13	24	12	346	178	57.5	42
80	M6	76.5	30	61.5	17.5	12	26	13	386	193	65	51
120	M8	111.5	45	91	22	22	59	32	546	273	100	76

Size	L5	L6	L7	T1	T2	T4	T6	T7	T8	T9	T10
70	27.5	2.3	218	2.1	18	7.2	–	10	12	3.1	12
80	31	2.3	243	2.1	29.5	4	2.1	10.1	12	2	12
120	50	2.5	332	3.1	29.5	4	–	16	16	2.1	25

- Note

The roller carriages of the standard design will be greased for the variant ELGA-TB-KF-F1. This will be done in accordance with the guidelines Doc.23 from EHEDG.

As part of this process, the standard grease except for small residual quantities will be replaced with a grease with NSF H1 approval.

Data sheet – For the food zone

Dimensions

Download CAD data → www.festo.com

Profile

Size 70

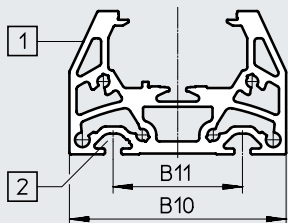

Size 80

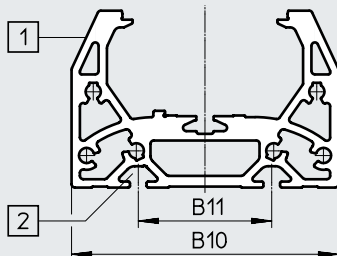

Size 120

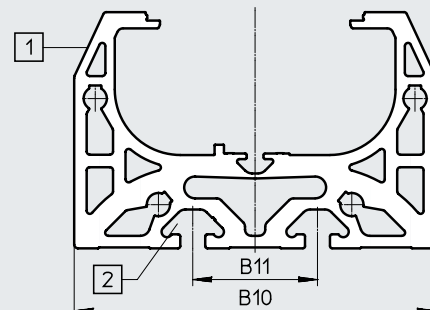

- [1] Sensor slot for proximity switch
- [2] Mounting slot for slot nut:
for size 70, 80: slot nut NST-5-M5
for size 120: slot nut NST-8-M6

Note

Requirements for the flatness of the bearing surface and of attachments as well as for use in parallel structures
→ www.festo.com/sp User documentation.

Size	B10	B11
70	67	40
80	80	40
120	116	40

Data sheet – For the food zone

Dimensions

Download CAD data → www.festo.com

Slide

Size 70

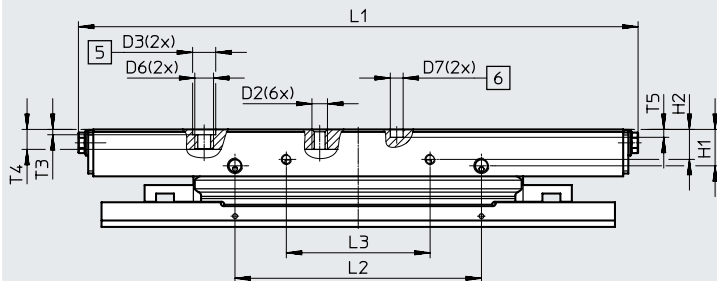

View A

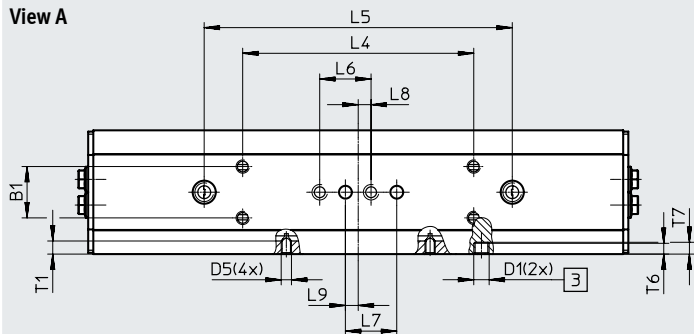

Size 80

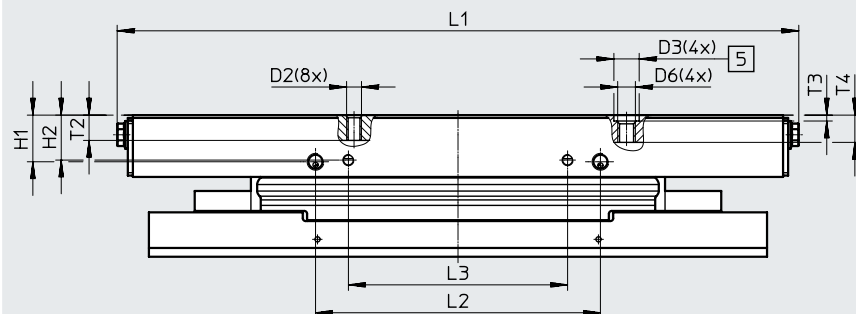

View A

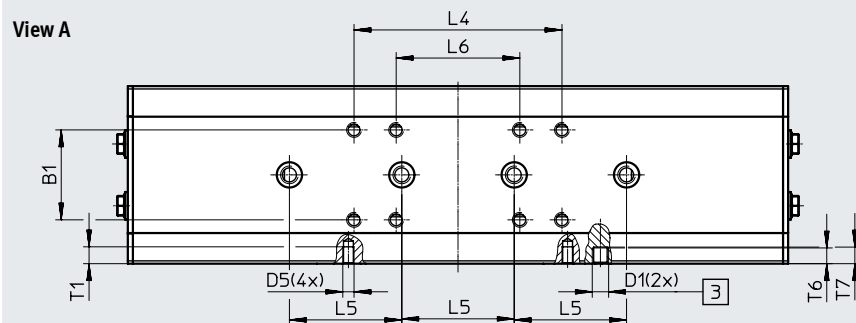

- [3] Lubrication connections
- [5] Drill hole for centring sleeve ZBH
- [6] Drill hole for centring pin ZBS

Size	B1	D1	D2	D3 ∅ H7	D5	D6	D7 ∅ H7	H1	H2	L1	L2	L3
70	±0.1	M6	M5	9	M4	M6	5	±0.1	±0.1	218	±0.1	±0.1
80	32	M6	M5	9	M4	M6	-	16.6	16	243	101.4	78

Size	L4	L5	L6	L7	L8	L9	T1	T2	T3	T4	T5	T6	T7
	±0.1	±0.03	±0.1	±0.03		±0.1			+0.1		±0.1	min.	max.
70	90	120	20	20	5	10	5.1	-	2.1	7.5	3.1	4.2	4.6 _{-0.1}
80	74	40	44	-	-	-	6	9	2.1	9.7 _{-0.2}	-	5.6	5.9 _{-0.1}

Data sheet – For the food zone

Dimensions

Download CAD data → www.festo.com

Slide

Size 120

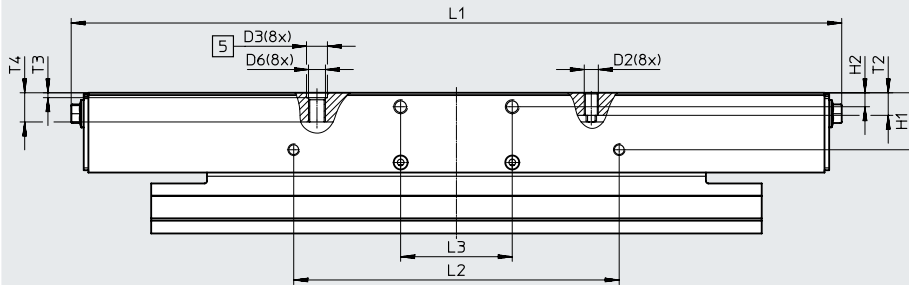

View A

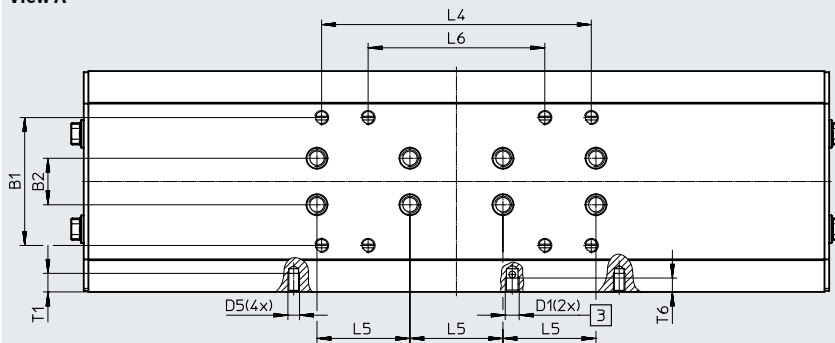

- [3] Lubrication connections
- [5] Drill hole for centring sleeve ZBH

Size	B1	B2	D1	D2	D3 ∅ H7	D5	D6	H1	H2	L1
	±0.2	±0.03						±0.1		
120	55	20	M6	M5	9	M5	M6	24.5	6	332

Size	L2	L3	L4	L5	L6	T1	T2	T3	T4	T6
	±0.1	±0.1	±0.2	±0.03	±0.2			+0.1	-0.3	
120	140	48	116	40	76	8	9.7	2.1	12.6	6

Ordering data – Modular product system – For the food zone

Orientation guide

- O top
- U bottom
- R right
- L left
- V front
- H rear

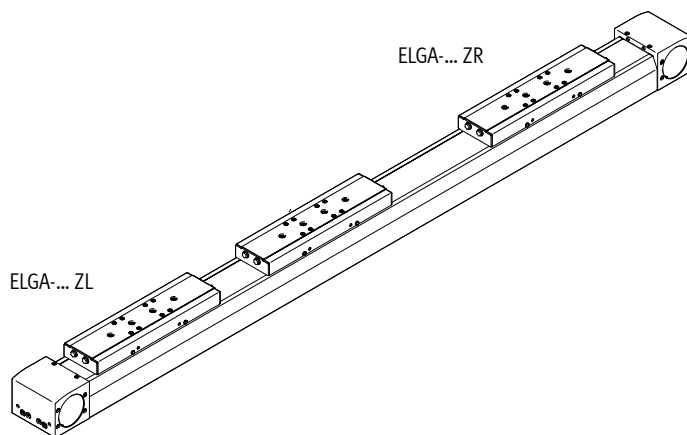
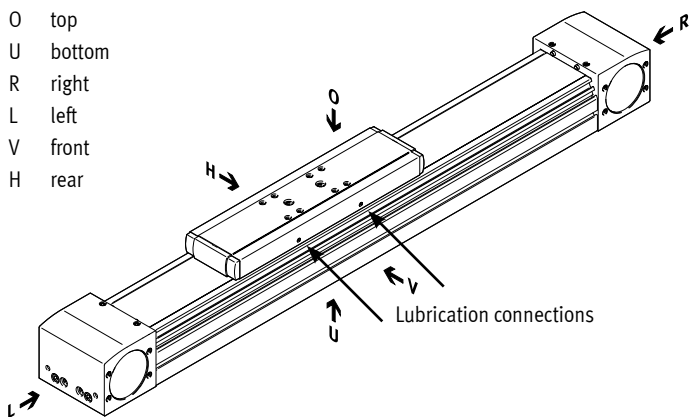

Accessories

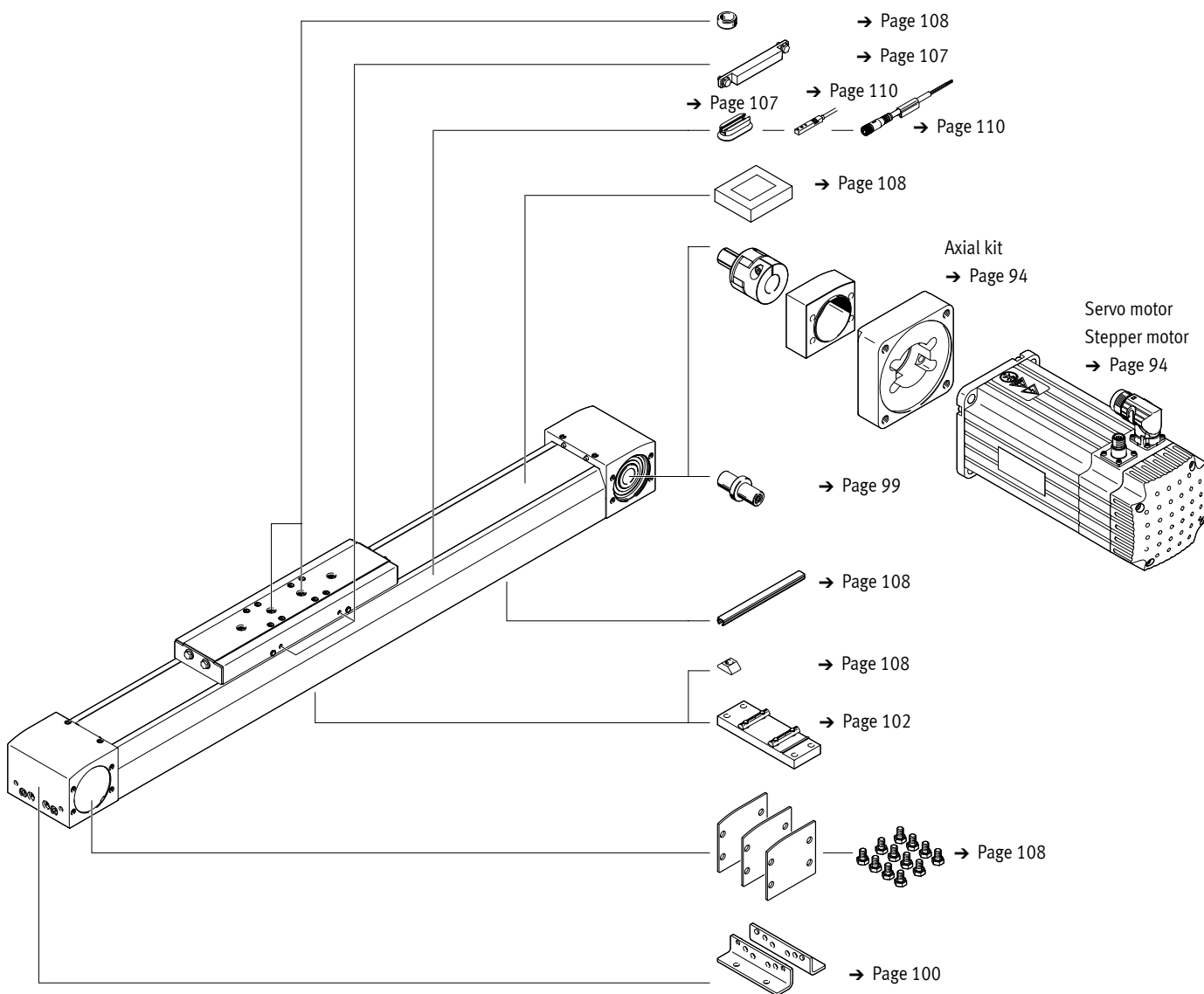

Ordering data – Modular products – For the food zone

Ordering table							Enter code
Size	70	80	120	Conditions	Code		
Module no.	8024914	8024915	8024916				
Design	Linear axis				ELGA		ELGA
Function	Toothed belt				-TB		-TB
Guide	Recirculating ball bearing guide				-KF		-KF
Size [mm]	70	80	120		-...		
Stroke length [mm]	1 ... 5000	1 ... 8500	1 ... 8500		-...		
Stroke reserve [mm]	0 ... 999 (0 = no stroke reserve)			[1]	-...H		
Additional slide	None						
	1 slide left				-ZL		
	1 slide right				-ZR		
Additional features	Food-safe as per supplementary material information				-F1		-F1
Material of toothed belt	Uncoated PU				-PU1		-PU1
Operating instructions	With operating instructions						
	Without operating instructions				-DN		

[1] ... H The sum of the nominal stroke and 2x stroke reserve must be at least 50 mm and must not exceed the maximum stroke length

Peripherals overview

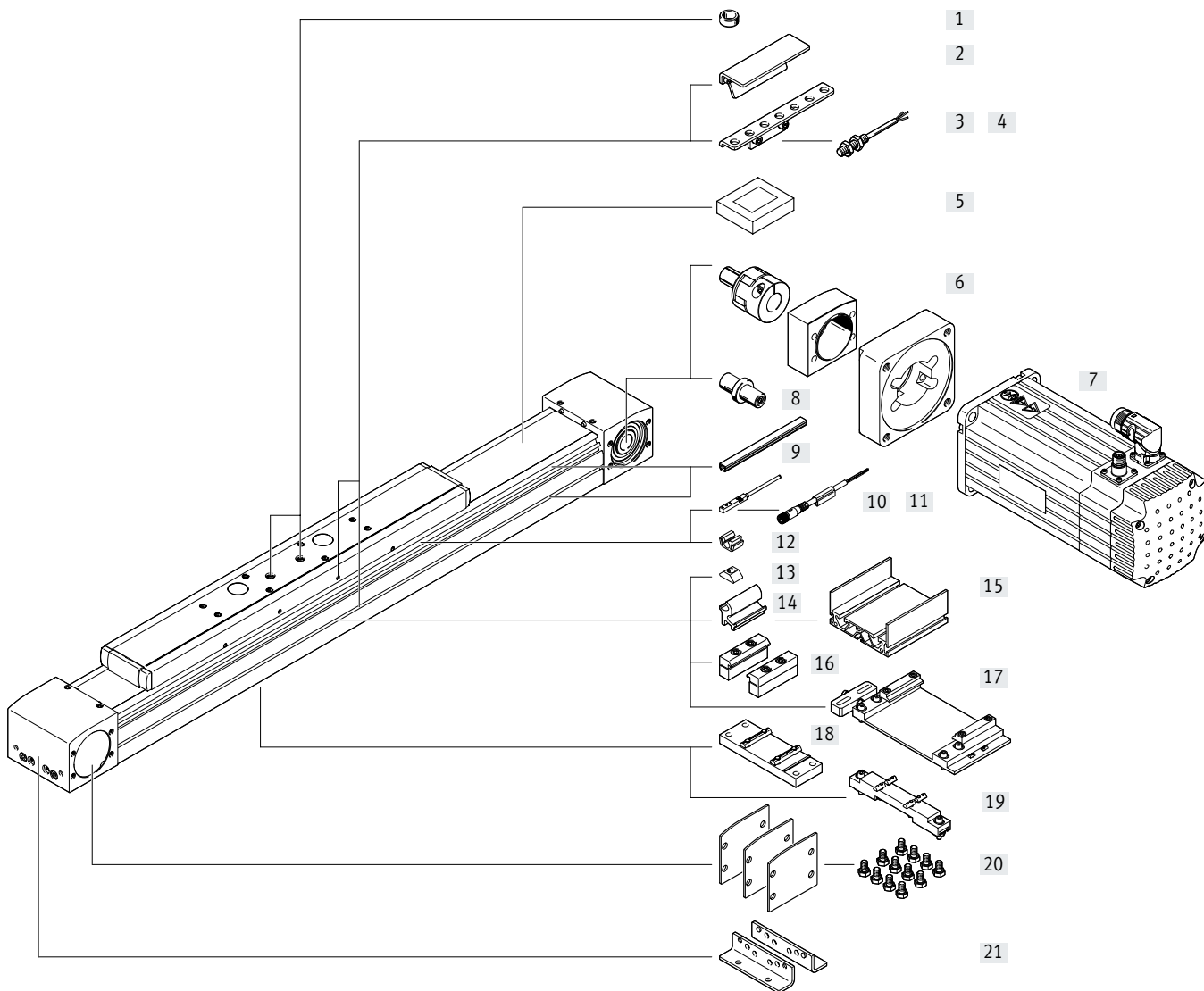

Slide variants

ELGA-...
Standard slide

ELGA-...-S
Short slide

ELGA-...-L
Long slide

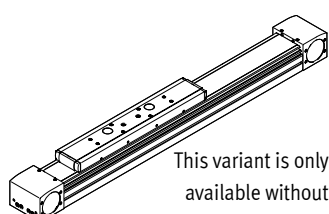
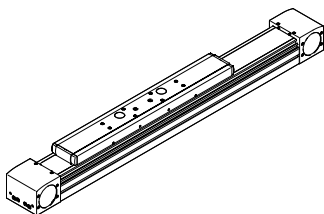

This variant is only available without cover strip.

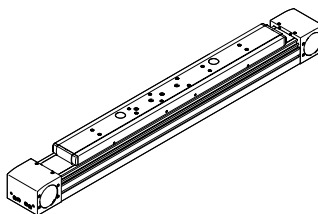

Peripherals overview

Accessories			
	Type/order code	Description	→ Page/Internet
[1]	Centring pin/sleeve ZBS, ZBH	<ul style="list-style-type: none"> For centring loads and attachments on the slide Included in the scope of delivery: <ul style="list-style-type: none"> For size 70, 80, 120: 2x ZBH-9 	108
[2]	Switch lug SA, SB, SC, SD, SE, SF	For sensing the slide position	105
[3]	Sensor bracket SC, SD, SE, SF	For mounting the inductive proximity switches (round design) on the axis	106
[4]	Proximity switch, M8 SC, SD, SE, SF	<ul style="list-style-type: none"> Inductive proximity switch, round design The order code SC, SD, SE, SF includes 1 switch lug and max. 2 sensor brackets in the scope of delivery 	110
[5]	Clamping element EADT	Tool for retensioning the cover strip	108
[6]	Axial kit EAMM	For axial motor mounting (comprises: coupling, coupling housing and motor flange)	94
[7]	Motor EMME, EMMS	Motors specially matched to the axis, with or without gear unit, with or without brake	94
[8]	Drive shaft EA	<ul style="list-style-type: none"> Can, if required, be used as an alternative interface No drive shaft is required for the axis/motor combinations → page 94 	99
[9]	Slot cover NS, NC	<ul style="list-style-type: none"> For protection against contamination 	108
[10]	Proximity switch, T-slot SA, SB	<ul style="list-style-type: none"> Inductive proximity switch, for T-slot The order code SA, SB includes 1 switch lug in the scope of delivery 	109
[11]	Connecting cable CA	For proximity switch (order code SE and SF)	110
[12]	Clip CM	For mounting the proximity switch cable in the slot	108
[13]	Slot nut NM	For mounting attachments	108
[14]	Adapter kit DHAM	For mounting the support profile on the axis	109
[15]	Support profile HMIA	For mounting and guiding an energy chain	109
[16]	Profile mounting MA	For mounting the axis on the side of the profile	101
[17]	Adjusting kit EADC-E16	For mounting the axis on a vertical surface. Once mounted, the axis can be aligned horizontally	104
[18]	Central support EAHF-L5	For mounting the axis on the profile from underneath	102
[19]	Adjusting kit EADC-E15	Is height-adjustable. Can be used to easily compensate for any unevenness in the bearing surface	103
[20]	Cover kit EASC-L5	For covering the sides of the drive cover	108
[21]	Foot mounting MF	<ul style="list-style-type: none"> For mounting the axis on the end cap With higher forces and torques, the axis should be mounted using the profile 	100



Type codes

001	Series	
ELGA	Gantry axis	
002	Drive system	
TB	Toothed belt	
003	Guide	
RF	Roller bearing	
004	Size	
70	70	
80	80	
120	120	
005	Stroke	
...	50 ... 7400	
006	Stroke reserve	
...H	0 ... 999	
007	Slide design	
	Standard	
S	Slide, short	
L	Slide, long	
008	Protection against particles	
	Standard	
P0	Without strip cover	
009	Additional characteristics	
	None	
F1	Food-safe according to supplementary information on materials	
010	Toothed belt material	
	Standard	
PU1	Uncoated PU, FDA-compliant	
PU2	Coated PU	
011	Foot mounting [units]	
	None	
MF	1	
012	Profile mounting	
	None	
...MA	1 ... 50	
013	Proximity sensor, inductive, slot 8, N/O contact, cable 7.5 m	
	None	
...SA	1 ... 6	

014	Proximity sensor, inductive, slot 8, N/C contact, cable 7.5 m	
	None	
...SB	1 ... 6	
015	Proximity sensor, inductive, M8, PNP, N/O contact, cable 2.5 m [units]	
	None	
...SC	1 ... 99	
016	Proximity sensor, inductive, M8, PNP, N/C contact, cable 2.5 m [units]	
	None	
...SD	1 ... 99	
017	Proximity sensor, inductive, M8, PNP, N/O contact, plug M8 [units]	
	None	
...SE	1 ... 99	
018	Proximity sensor, inductive, M8, PNP, N/C contact, plug M8 [units]	
	None	
...SF	1 ... 99	
019	Connecting cable, M8, 2.5 m [units]	
	None	
...CA	1 ... 99	
020	Cover, sensor slot [units]	
	None	
...NS	1 ... 50	
021	Mounting slot covering	
	None	
...NC	1 ... 50	
022	Slot nut for mounting slot	
	None	
...NM	1 ... 99	
023	Cable clip [units]	
	None	
...CM	10, 20, 30, 40, 50, 60, 70, 80, 90	
024	Drive shaft [units]	
	None	
...EA	1 ... 4	
025	Operating instructions	
	With operating instructions	
DN	Without operating instructions	

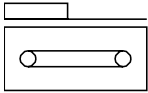
Data sheet



-  Size
70 ... 120
-  Stroke length
50 ... 7400 mm
-  www.festo.com

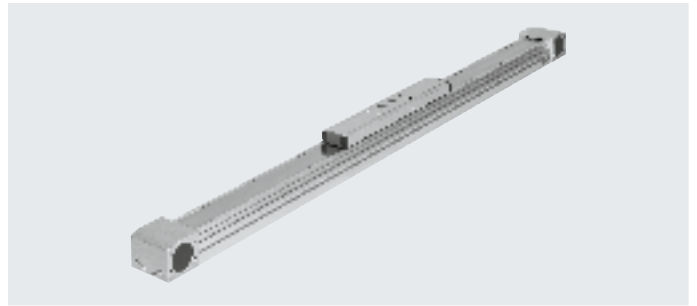

General technical data				
Size		70	80	120
Design		Electromechanical axis with toothed belt		
Guide		Roller guide		
Mounting position		Any		
Working stroke				
ELGA-...	[mm]	50 ... 7000	50 ... 7000	50 ... 7400
ELGA-...S	[mm]	50 ... 7000	50 ... 7000	50 ... 7400
ELGA-...L	[mm]	50 ... 6900	50 ... 6900	50 ... 7200
Max. feed force F_x	[N]	350	800	1300
Max. no-load torque ¹⁾	[Nm]	0.66	1.35	3
Max. no-load resistance to shifting ¹⁾	[N]	46	68	114
Max. driving torque	[Nm]	5	15.9	34.1
Max. speed	[m/s]	10		
Max. acceleration	[m/s ²]	50		
Repetition accuracy	[mm]	±0.08		

1) At 0.2 m/s

Operating and environmental conditions		
Ambient temperature ¹⁾	[°C]	-10 ... +60
Degree of protection		
ELGA-...		IP40
ELGA-...-P0		IP00
Duty cycle	[%]	100

1) Note operating range of proximity switches

Weight [kg]				
Size		70	80	120
Basic weight with 0 mm stroke ¹⁾				
ELGA-...		2.78	6.25	17.39
ELGA-...S		2.39	5.62	15.82
ELGA-...L		3.33	7.49	21.44
Additional weight per 1000 mm stroke				
ELGA-...		3.29	5.17	10.81
ELGA-...-P0		3.18	5.06	10.66
Moving mass				
ELGA-...		0.80	2.01	5.08
ELGA-...S		0.70	1.85	4.65
ELGA-...L		1.03	2.53	6.63

1) Incl. slide

Data sheet

Toothed belt				
Size		70	80	120
Pitch	[mm]	3	5	5
Elongation ¹⁾				
ELGA-...	[%]	0.213	0.168	0.21
ELGA-...-PU2	[%]	0.105	0.1	0.122
Effective diameter	[mm]	28.65	39.79	52.52
Feed constant	[mm/rev]	90	125	165

1) At max. feed force

Mass moment of inertia				
Size		70	80	120
J_0				
ELGA-...	[kg mm ²]	232	1044	4935
ELGA-...-S	[kg mm ²]	207	968	4592
ELGA-...-L	[kg mm ²]	278	1247	6006
J_H per metre stroke	[kg mm ² /m]	19	97	221
J_L per kg payload	[kg mm ² /kg]	205	396	690

The mass moment of inertia J_A of the entire axis is calculated as follows:

$$J_A = J_0 + J_H \times \text{working stroke [m]} + J_L \times m_{\text{payload [kg]}}$$

Materials

Sectional view

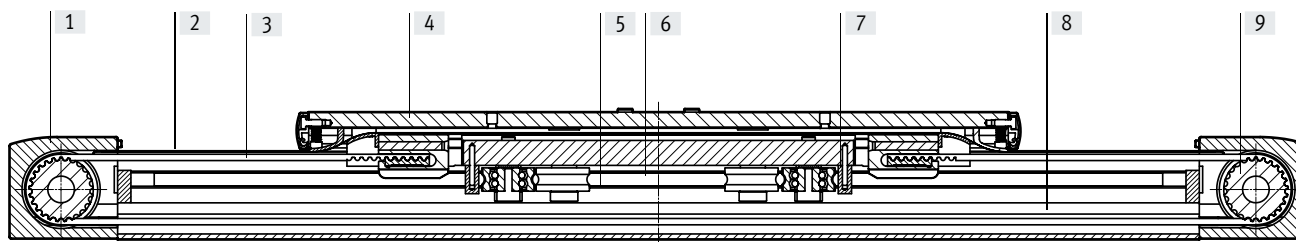

Axis		
[1]	Drive cover	Anodised wrought aluminium alloy
[2]	Cover strip	Stainless steel strip, non-corroding
[3]	Toothed belt	
	ELGA-...	Polychloroprene with glass cord and nylon coating
	ELGA-...-PU2	Polyurethane with steel cord and nylon covering
[4]	Slide	Anodised wrought aluminium alloy
[5]	Castor	Hardened rolled steel
[6]	Guide rod	Hardened and hard-chromium plated tempered steel
[7]	Scraper	Oil-impregnated felt
[8]	Profile	Anodised wrought aluminium alloy
[9]	Toothed belt pulley	High-alloy stainless steel
Note on materials		RoHS-compliant Contains paint-wetting impairment substances

Data sheet

Characteristic load values

The indicated forces and torques refer to the slide surface. The point of application of force is the point where the centre of the guide and the longitudinal centre of the slide intersect.

These values must not be exceeded during dynamic operation. Special attention must be paid to the cushioning phase.

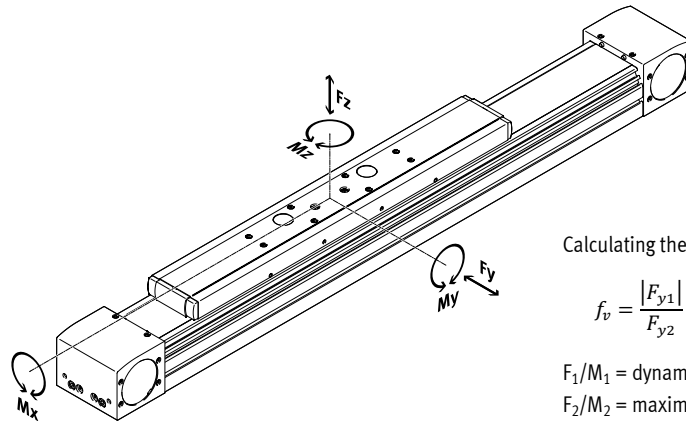

If the axis is subjected to two or more of the indicated forces and torques simultaneously, the following equation must be satisfied in addition to the indicated maximum loads:

Calculating the load comparison factor:

$$f_v = \frac{|F_{y1}|}{F_{y2}} + \frac{|F_{z1}|}{F_{z2}} + \frac{|M_{x1}|}{M_{x2}} + \frac{|M_{y1}|}{M_{y2}} + \frac{|M_{z1}|}{M_{z2}} \leq 1$$

F_1/M_1 = dynamic value

F_2/M_2 = maximum value

Max. permissible forces and torques for a service life of 10000 km				
Size		70	80	120
$F_{y_{max}}$	[N]	500	800	2000
$F_{z_{max}}$	[N]	500	800	2000
$M_{x_{max}}$	[Nm]	11	30	100
$M_{y_{max}}$				
ELGA-...	[Nm]	20	90	320
ELGA-...-S	[Nm]	20	90	320
ELGA-...-L	[Nm]	40	180	640
$M_{z_{max}}$				
ELGA-...	[Nm]	20	90	320
ELGA-...-S	[Nm]	20	90	320
ELGA-...-L	[Nm]	40	180	640

Data sheet

Calculating the service life

The service life of the guide depends on the load. To be able to make a statement as to the service life of the guide, the graph below plots the load comparison factor f_v against the service life.

These values are only theoretical. You must consult your local Festo contact for a load comparison factor f_v greater than 1.5.

Load comparison factor f_v as a function of service life

Example:

A user wants to move an X kg load. Using the formula (→ page 51) gives a value of 1.5 for the load comparison factor f_v . According to the graph, the guide would have a service life of approx. 3000 km. Reducing the acceleration reduces the M_z and M_y values. A load comparison factor f_v of 1 now gives a service life of 10000 km.

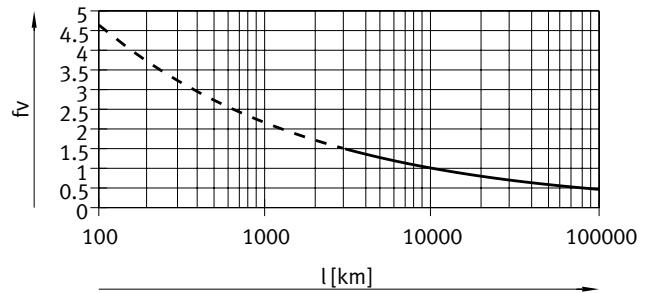

Note

Engineering software
PositioningDrives
www.festo.com

The software can be used to calculate a guide workload for a service life of 5000 km.

$f_v > 1.5$ are only theoretical comparison values for the recirculating ball bearing guide.

Data sheet

Max. acceleration a as a function of payload m

Size 70

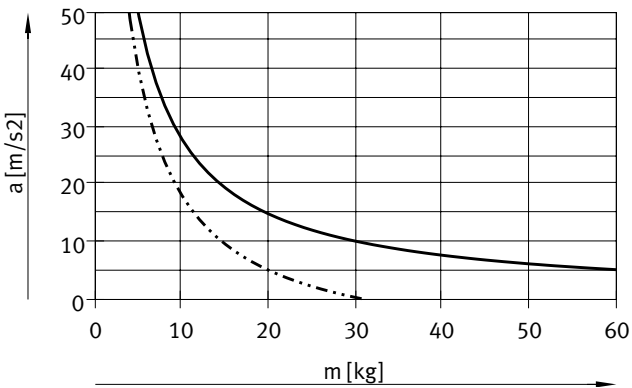

Size 80

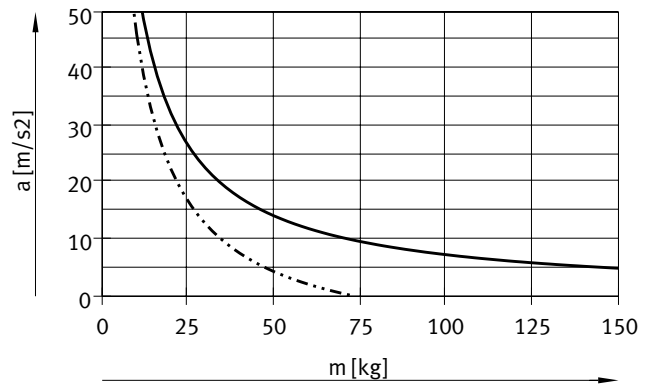

Size 120

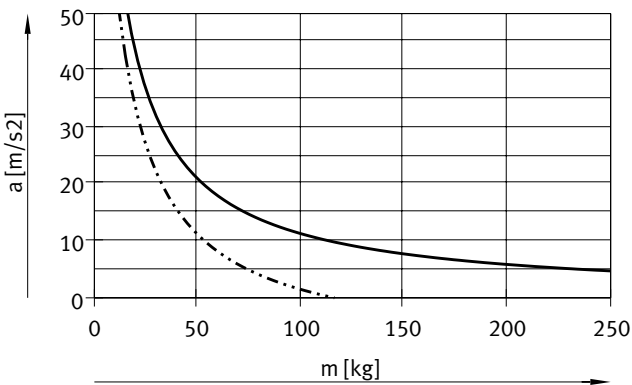

— Horizontal mounting position
 - - - Vertical mounting position

Speed v as a function of rotational speed n

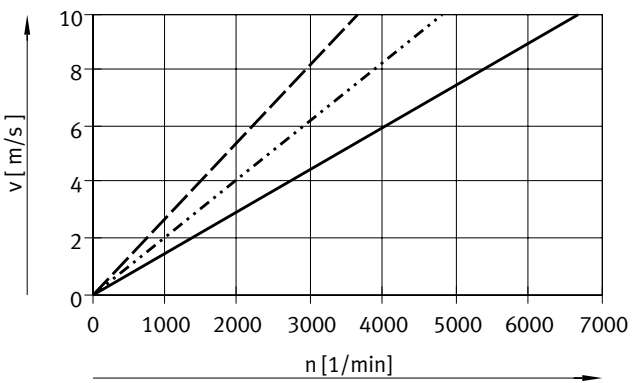

— ELGA-TB-RF-70
 ELGA-TB-RF-80
 - - - ELGA-TB-RF-120

Data sheet

Theoretical feed force F as a function of input torque M

Size 70

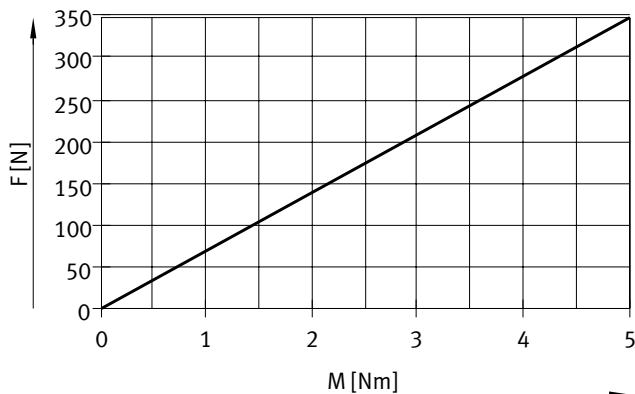

ELGA-TB-RF-70

Size 80/120

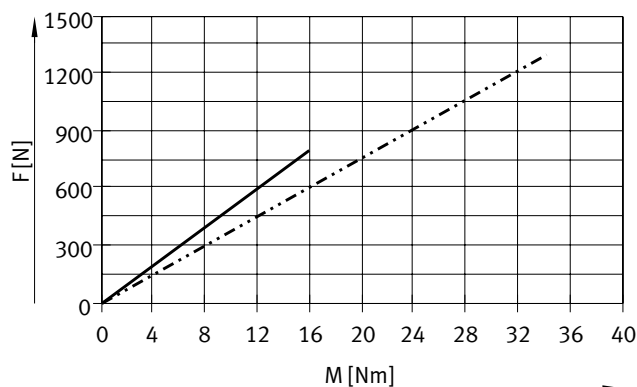

ELGA-TB-RF-80

ELGA-TB-RF-120

Stroke reserve

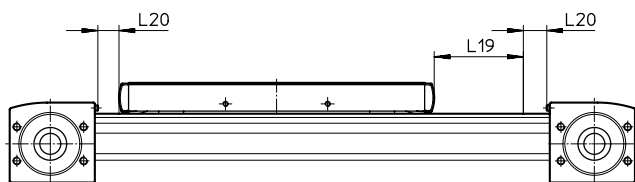

L19 = Nominal stroke
L20 = Stroke reserve

- The stroke reserve is a safety distance from the mechanical end position and is not used in normal operation
 - The sum of the nominal stroke and 2x stroke reserve must not exceed the maximum permissible working stroke
 - The stroke reserve length can be freely selected
 - The stroke reserve is defined via the "stroke reserve" characteristic in the modular product system.
- Example:**
 Type ELGA-TB-RF-70-500-20H-...
 Nominal stroke = 500 mm
 2x stroke reserve = 40 mm
 Working stroke = 540 mm
 (540 mm = 500 mm + 2x 20 mm)

Second moment of area

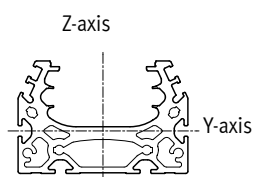

Size		70	80	120
ly	[mm ⁴]	1.39x10 ⁵	2.70x10 ⁵	1.42x10 ⁶
lz	[mm ⁴]	4.33x10 ⁵	1.02x10 ⁶	5.02x10 ⁶

Data sheet

Maximum permissible support spacing L (without profile mounting MUE/central support EAHF) as a function of force F

In order to limit deflection in the case of large strokes, the axis may need to be supported.

The following graphs can be used to determine the maximum permissible support spacing l as a function of force F acting on the axis. The deflection is $f = 0.5$ mm.

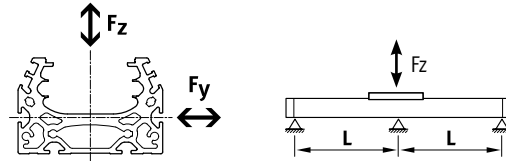
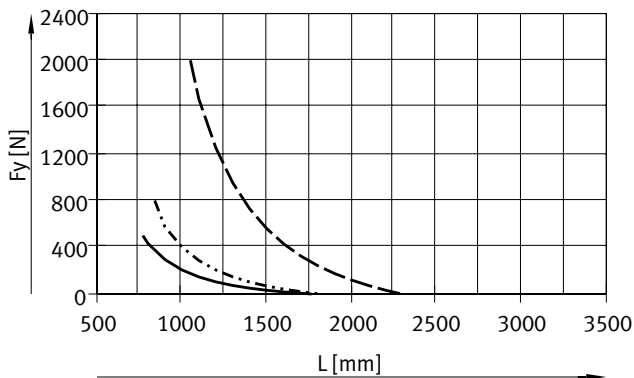
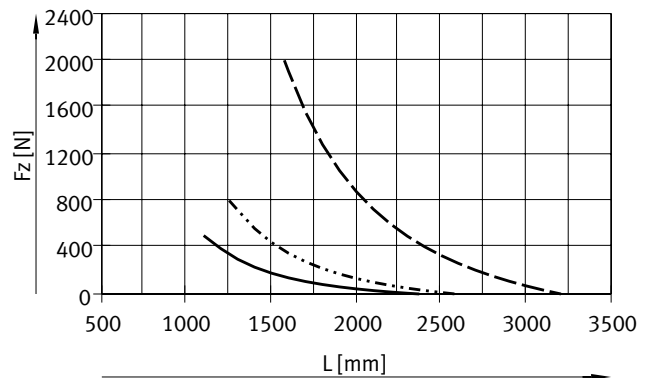
Force F_y Force F_z 

- ELGA-TB-RF-70
- · - · - ELGA-TB-RF-80
- - - ELGA-TB-RF-120

Recommended deflection limits

Adherence to the following deflection limits is recommended so as not to impair the functionality of the axes.

Greater deformation can result in increased friction, greater wear and reduced service life.

Size	Dynamic deflection (moving load)	Static deflection (stationary load)
70 ... 120	0.05% of the axis length, max. 0.5 mm	0.1% of the axis length

Data sheet

Dimensions

Download CAD data → www.festo.com

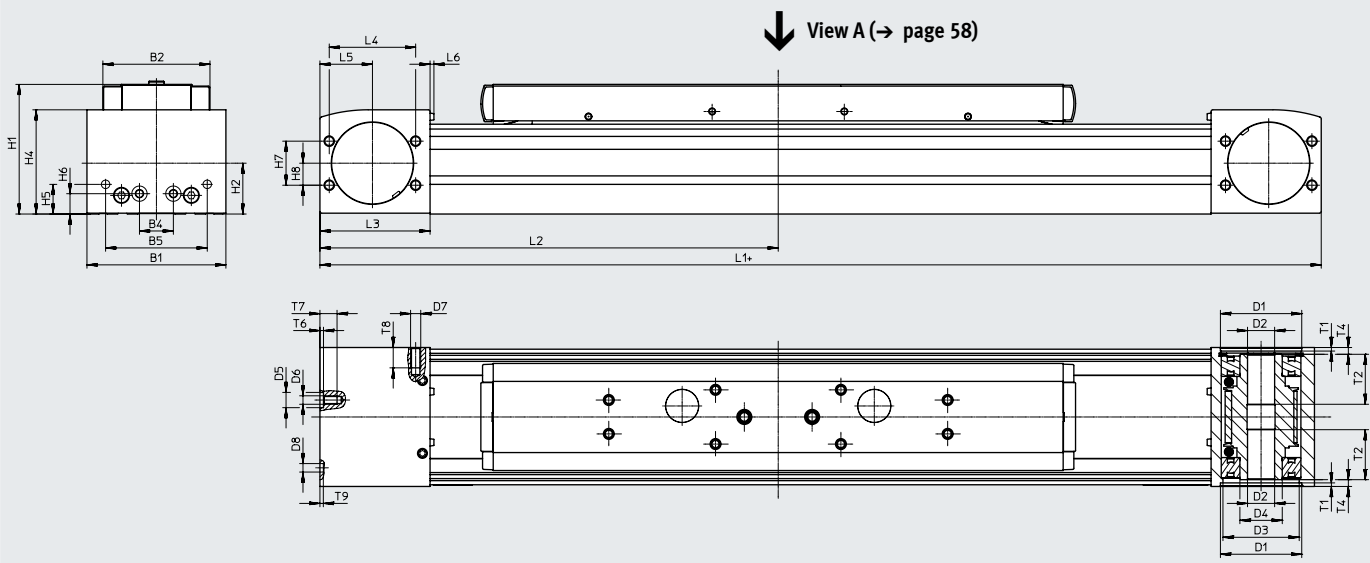

+ = plus stroke length + 2x stroke reserve

Size	B1	B2	B4	B5	D1 ∅ H7	D2 ∅ H7	D3 ∅	D4 ∅	D5 ∅ H7	D6
70	69	48.2	30	45	38	16	34	25	-	M5
80	82	63.2	20	60	48	16	45	25	9	M5
120	120	95	80	40	80	23	72	45	-	M8

Size	D7	D8 ∅ H7	H1	H2	H4	H5	H6	H7	H8	L3
70	M6	5	64	26.5	50.8	13	13	24	12	57.5
80	M6	5	76.5	30	61.5	17.5	12	26	13	65
120	M8	9	111.5	45	91	22	22	59	32	100

Size	L4	L5	L6	T1	T2	T4	T6	T7	T8	T9
70	42	27.5	2.3	2.1	18	7.15	-	10	12	3.1
80	51	31	2.3	2.1	29.5	4	2.1	10.1	12	2
120	76	50	2.5	3.1	29.5	4	-	16	16	2.1

Size Slide design	L1			L2		
	ELGA-...	ELGA-...-S	ELGA-...-L	ELGA-... min.	ELGA-...-S min.	ELGA-...-L min.
70	420	342	520	210	171	260
80	580	496	720	290	248	360
120	775	673	1005	387.5	336.5	502.5

Data sheet

Dimensions

Download CAD data → www.festo.com

Profile

Size 70

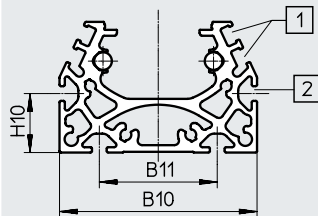

Size 80

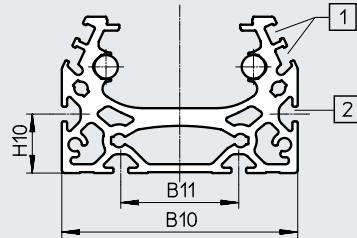

Size 120

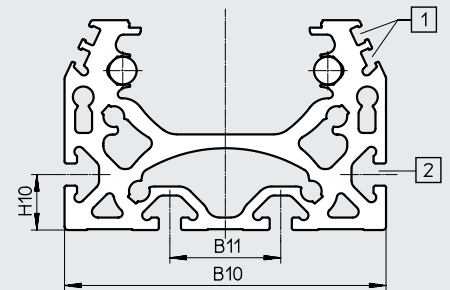

- [1] Sensor slot for proximity switch
 [2] Mounting slot for slot nut:
 for size 70, 80: slot nut NST-5-M5
 for size 120: slot nut NST-8-M6

Size	B10	B11	H10
70	67	40	20
80	80	40	20
120	116	40	20

 **Note**

Requirements for the flatness of the bearing surface and of attachments as well as for use in parallel structures

→ www.festo.com/sp
 User documentation

Data sheet

Dimensions

Download CAD data → www.festo.com

ELGA... – Standard slide

Size 70

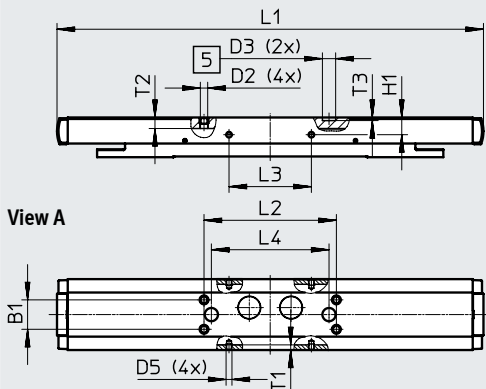

Size 80

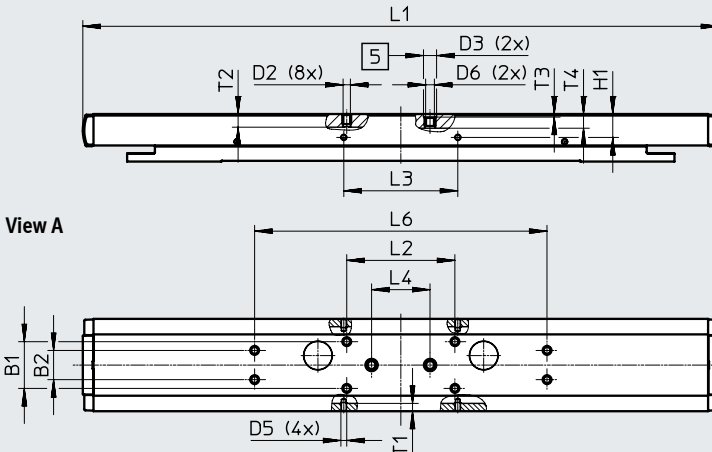

Size 120

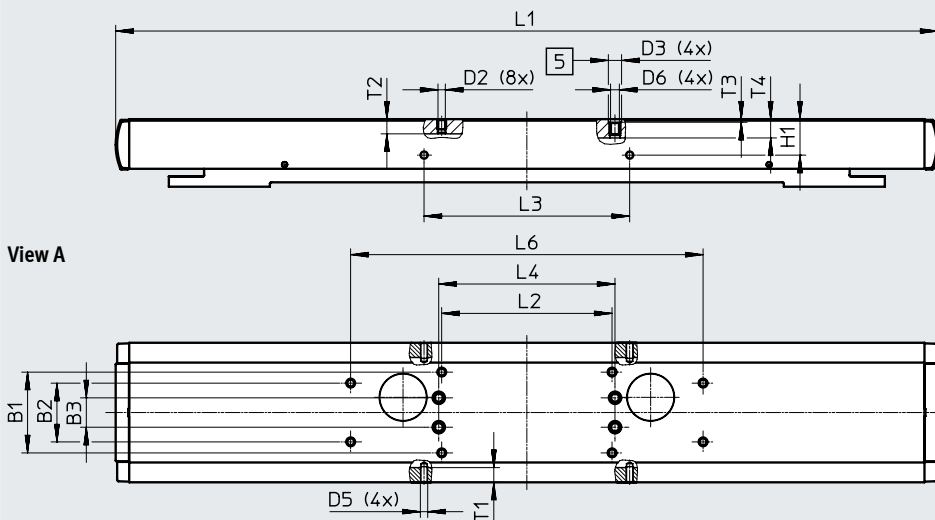

[5] Drill hole for centring sleeve

Size	B1	B2	B3	D2	D3 ∅ H7	D5	D6	H1
	±0.1	±0.1	±0.1					±0.1
70	20	-	-	M5	9	M4	-	11.7
80	32	20	-	M5	9	M4	M6	16
120	55	40	20	M5	9	M5	M6	24.5

Size	L1	L2	L3	L4	L6	T1	T2	T3	T4
		±0.2	±0.1	±0.03	±0.2				
70	290	90	56	80	-	3.5	7.5	2.1	-
80	435	74	78	40	200	5.1	9	2.1	9.7
120	560	116	140	120	240	10	10	2.1	12.8

Data sheet

Dimensions

Download CAD data → www.festo.com

ELGA-...S – Short slide

Size 70

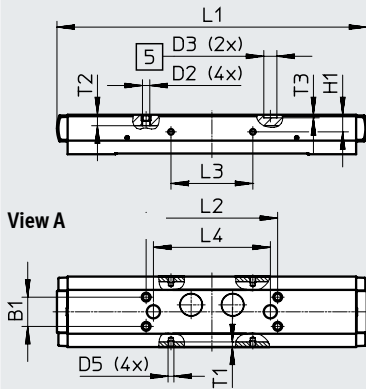

Size 80

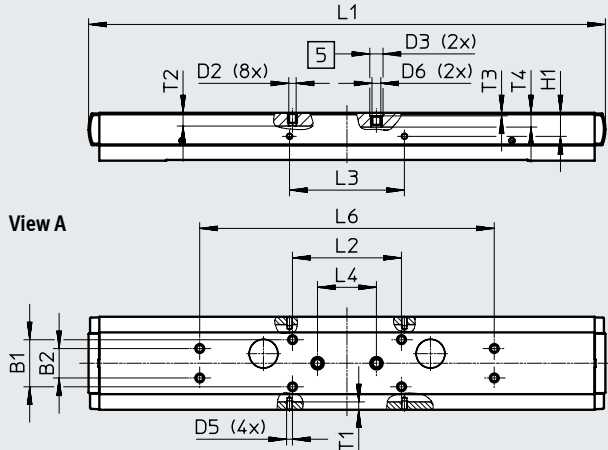

Size 120

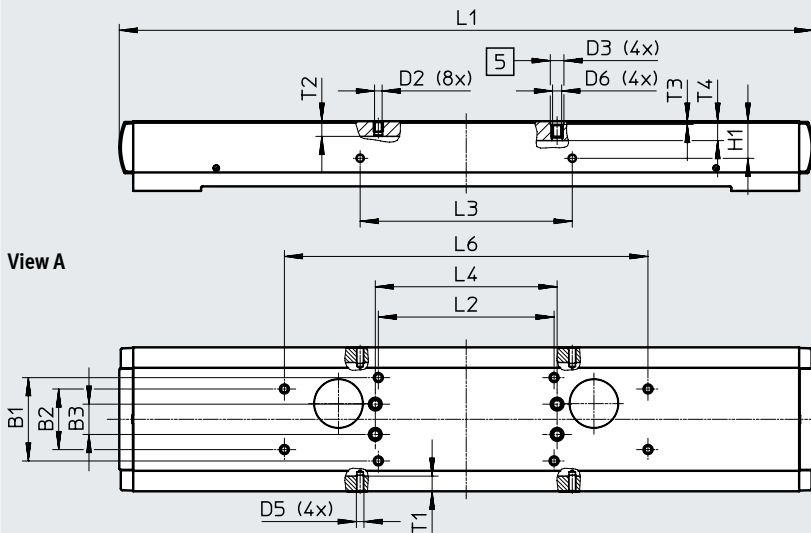

[5] Drill hole for centring sleeve

Size	B1	B2	B3	D2	D3 ∅	D5	D6	H1
	±0.1	±0.1	±0.1		H7			±0.1
70	20	-	-	M5	9	M4	-	11.7
80	32	20	-	M5	9	M4	M6	16
120	55	40	20	M5	9	M5	M6	24.5

Size	L1	L2	L3	L4	L6	T1	T2	T3	T4
		±0.2	±0.1	±0.03	±0.2				
70	212	90	56	80	-	3.5	7.5	2.1	-
80	351	74	78	40	200	5.1	9	2.1	9.7
120	458	116	140	120	240	10	10	2.1	12.8

Data sheet

Dimensions

Download CAD data → www.festo.com

ELGA...-L – Long slide

Size 70

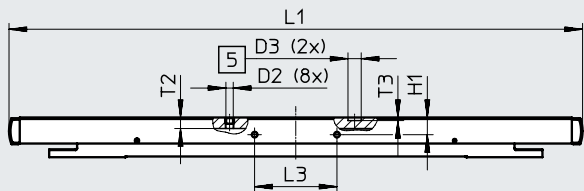

View A

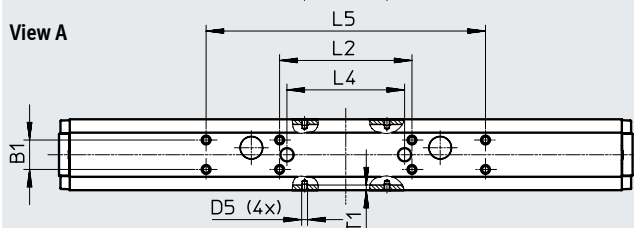

Size 80

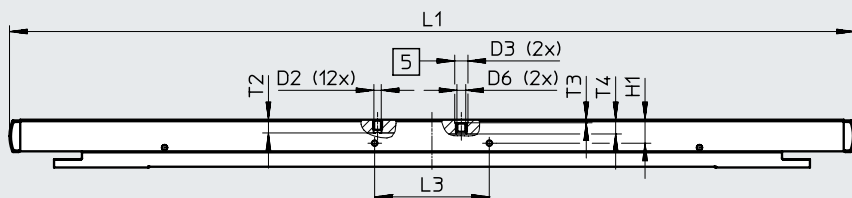

View A

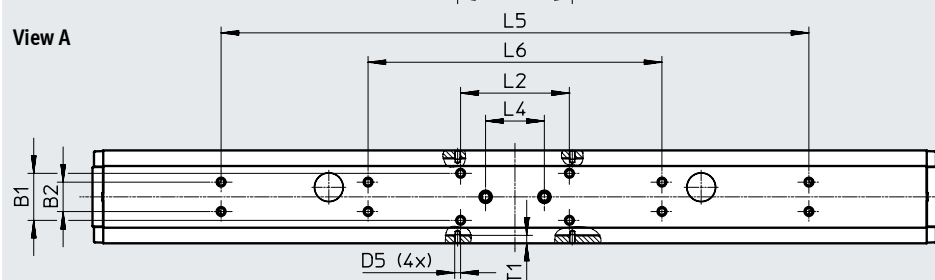

Size 120

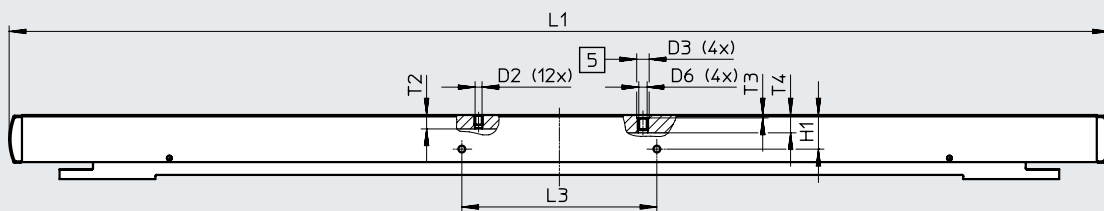

View A

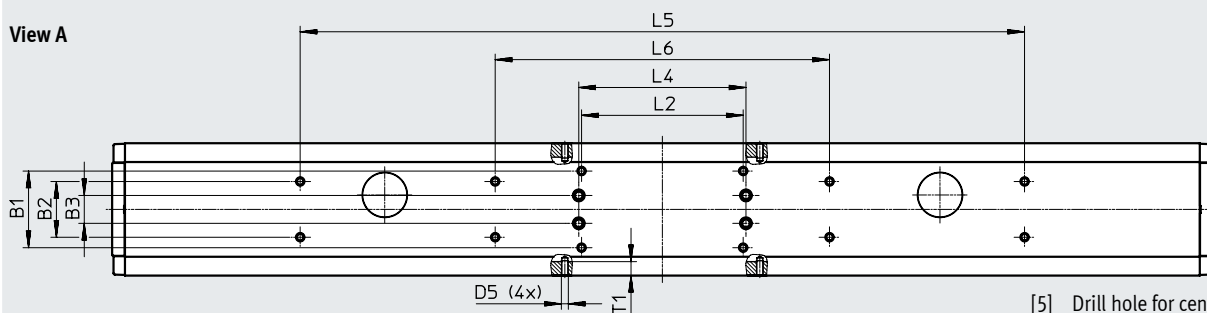

[5] Drill hole for centring sleeve

Data sheet

Size	B1 ±0.1	B2 ±0.1	B3 ±0.1	D2	D3 ∅ H7	D5
70	20	–	–	M5	9	M4
80	32	20	–	M5	9	M4
120	55	40	20	M5	9	M5

Size	D6	H1 ±0.1	L1	L2 ±0.2	L3 ±0.1	L4 ±0.03
70	–	11.7	390	90	56	80
80	M6	16	575	74	78	40
120	M6	24.5	790	116	140	120

Size	L5 ±0.2	L6 ±0.2	T1	T2	T3	T4
70	190	–	3.5	7.5	2.1	–
80	400	200	5.1	9	2.1	9.7
120	520	240	10	10	2.1	12.8

Ordering data – Modular product system

Accessories

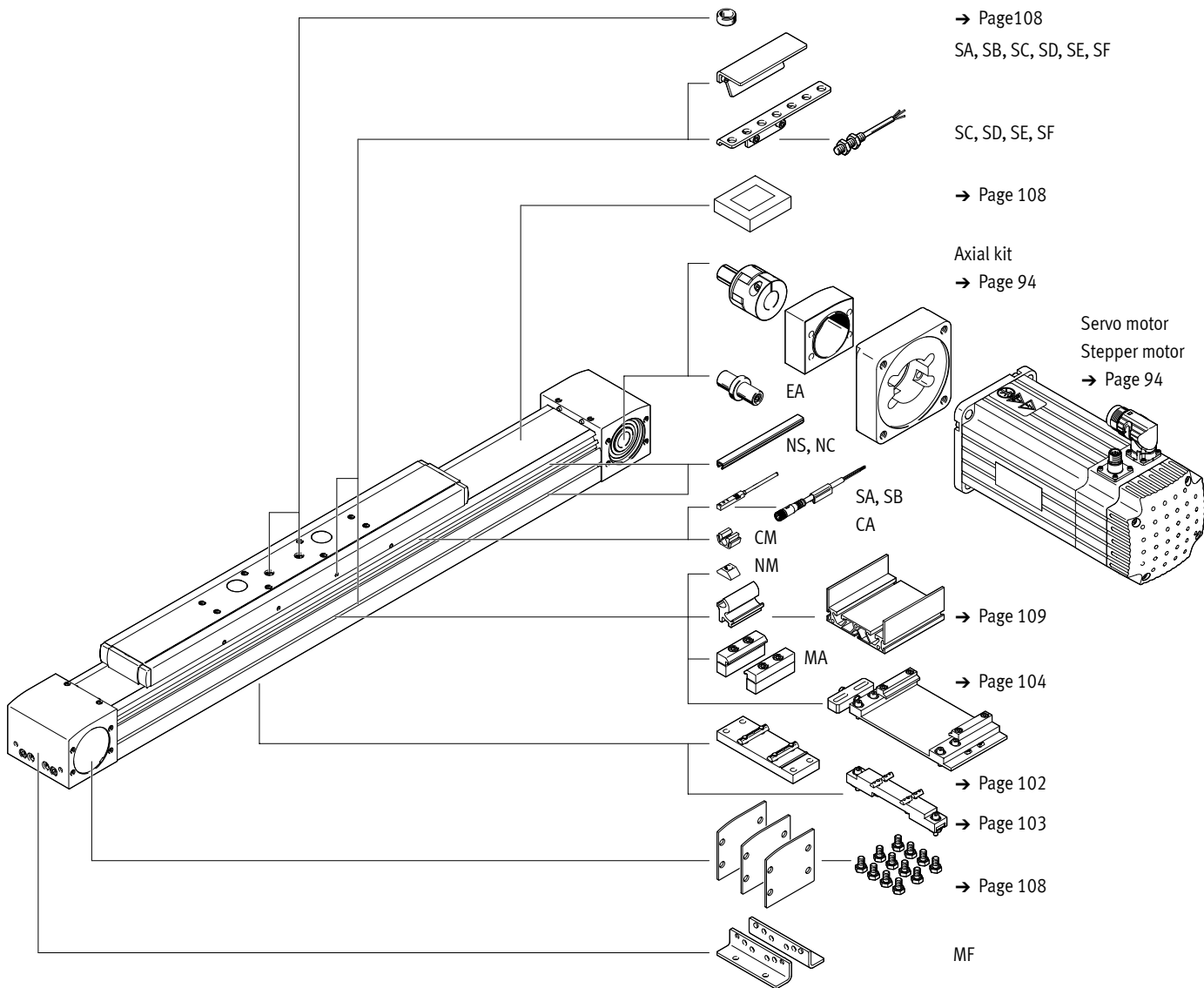

Ordering data – Modular product system

Ordering table		70	80	120	Conditions	Code	Enter code
Size		70	80	120			
Module no.		1371245	1371246	1371247			
Design		Linear axis				ELGA	ELGA
Function		Toothed belt				★ -TB	-TB
Guide		Roller guide				★ -RF	-RF
Size	[mm]	70	80	120		★ -...	
Stroke length	[mm]	1 ... 7000	1 ... 7000	1 ... 7400		★ -...	
Stroke reserve	[mm]	0 ... 999 (0 = no stroke reserve)			[1]	★ -...H	
Slide design	Standard slide	50 ... 7000 50 ... 7000 50 ... 7400				★	
	Short slide	50 ... 7000 50 ... 7000 50 ... 7400			[2]	★ -S	
	Long slide	50 ... 6900 50 ... 6900 50 ... 7200				★ -L	
Protection against particles	Standard					★	
	Without cover strip					★ -P0	
Material of toothed belt	Chloroprene rubber						
	Coated PU					-PU2	
Accessories	Accessories enclosed separately					+	+
Foot mounting		1				MF	
Profile mounting		1 ... 50				...MA	
Proximity switch (SIES), inductive, slot type O, PNP, incl. switch lug	N/O contact, 7.5 m cable	1 ... 6				...SA	
	N/C contact, 7.5 m cable	1 ... 6				...SB	
Proximity switch (SIEN), inductive, M8, PNP, incl. switch lug with sensor bracket	N/O contact, 2.5 m cable	1 ... 99				...SC	
	N/C contact, 2.5 m cable	1 ... 99				...SD	
	N/O contact, M8 plug	1 ... 99				...SE	
	N/C contact, M8 plug	1 ... 99				...SF	
Connecting cable 2.5 m, M8, 3-wire		1 ... 99				...CA	
Sensor slot cover		1 ... 50 (1 = 2 units, 500 mm)				...NS	
Mounting slot cover		1 ... 50 (1 = 2 units, 500 mm)				...NC	
Slot nut for mounting slot		1 ... 99				...NM	
Clip for sensor slot		10, 20, 30, 40, 50, 60, 70, 80, 90				...CM	
Drive shaft		1 ... 4				...EA	
Operating instructions	With operating instructions						
	Without operating instructions					-DN	

[1] ... H The sum of the nominal stroke and 2x stroke reserve must be at least 50 mm and must not exceed the maximum stroke length

[2] S Only with P0

 **Note**

The code SA, SB includes a switch lug in the scope of delivery.

The code SC, SD, SE, SF includes one switch lug and max. two sensor brackets in the scope of delivery.

Festo core product range



Generally ready for dispatch from the factory within 24 hours

Generally ready for dispatch from the factory within 5 days

Peripherals overview – For the food zone

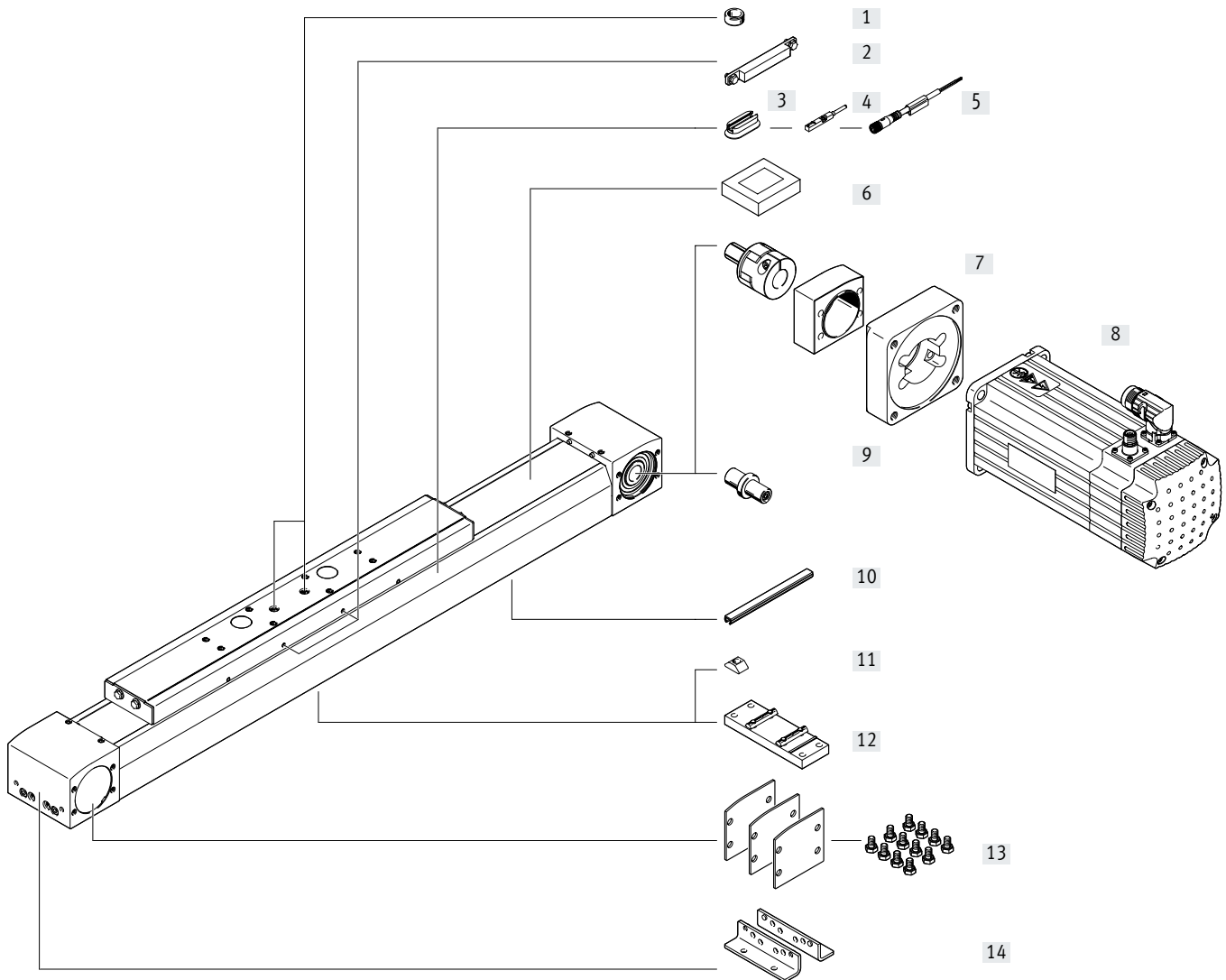

Slide variants

ELGA-...-F1

Standard slide

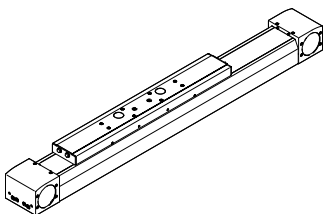

ELGA-...-S-F1

Short slide

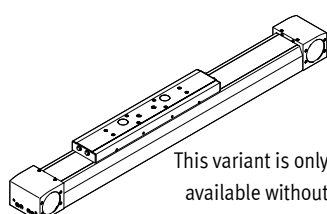

This variant is only available without cover strip.

ELGA-...-L-F1

Long slide

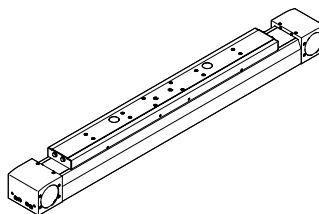



Peripherals overview – For the food zone

Accessories			
	Type/order code	Description	→ Page/Internet
[1]	Centring pin/sleeve ZBS, ZBH	<ul style="list-style-type: none"> For centring loads and attachments on the slide Included in the scope of delivery: <ul style="list-style-type: none"> For size 70, 80, 120: 2x ZBH-9 	108
[2]	Switch lug EAPM	For sensing the slide position	107
[3]	Mounting kit CRSMB	For mounting the proximity switches on the axis	107
[4]	Proximity switch, T-slot SME-8M	For sensing the slide position	110
[5]	Connecting cable NEBU	For proximity switch	110
[6]	Clamping element EADT	Tool for retensioning the cover strip	108
[7]	Axial kit EAMM	For axial motor mounting (comprises: coupling, coupling housing and motor flange)	94
[8]	Motor EMME, EMMS	Motors specially matched to the axis, with or without gear unit, with or without brake	94
[9]	Drive shaft EA	<ul style="list-style-type: none"> Can, if required, be used as an alternative interface No drive shaft is required for the axis/motor combinations → page 94 	99
[10]	Slot cover NC	<ul style="list-style-type: none"> For protection against contamination 	108
[11]	Slot nut NM	For mounting attachments	108
[12]	Central support EAHF-L5	For mounting the axis on the profile from underneath	102
[13]	Cover kit EASC-L5	For covering the sides of the drive cover	108
[14]	Foot mounting MF	For mounting the axis on the end cap.	100

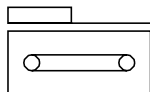
Data sheet – For the food zone



-  Size
70 ... 120
-  Stroke length
50 ... 7400 mm
-  www.festo.com

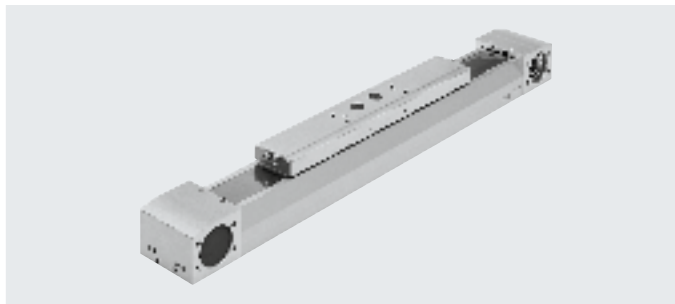

General technical data		70	80	120
Size		70	80	120
Design		Electromechanical axis with toothed belt		
Guide		Roller guide		
Mounting position		Any		
Working stroke				
ELGA-...	[mm]	50 ... 7000	50 ... 7000	50 ... 7400
ELGA-...-S	[mm]	50 ... 7000	50 ... 7000	50 ... 7400
ELGA-...-L	[mm]	50 ... 6900	50 ... 6900	50 ... 7200
Max. feed force F_x	[N]	260	600	1000
Max. no-load torque ¹⁾	[Nm]	1.03	1.93	5.67
Max. no-load resistance to shifting ¹⁾	[N]	72	97	216
Max. driving torque	[Nm]	3.7	11.9	26.2
Max. speed	[m/s]	10		
Max. acceleration	[m/s ²]	50		
Repetition accuracy	[mm]	±0.08		

1) At 0.2 m/s

Operating and environmental conditions		
Ambient temperature ¹⁾	[°C]	-10 ... +60
Degree of protection		
ELGA-...		IP40
ELGA-...-P0		IP00
Duty cycle	[%]	100
Food-safe ²⁾		→ Supplementary material information

1) Note operating range of proximity switches.

2) Additional information www.festo.com/sp → Certificates.

Weight [kg]		70	80	120
Basic weight with 0 mm stroke ¹⁾				
ELGA-...		2.81	6.17	17.17
ELGA-...-S		2.43	5.56	15.65
ELGA-...-L		3.38	7.36	21.11
Additional weight per 1000 mm stroke				
ELGA-...		3.36	4.87	10.34
ELGA-...-P0		3.24	4.77	10.19
Moving mass				
ELGA-...		0.82	2.04	5.14
ELGA-...-S		0.75	1.97	4.87
ELGA-...-L		1.04	2.55	6.69

1) Incl. slide

Data sheet – For the food zone

Toothed belt		70	80	120
Size		70	80	120
Pitch	[mm]	3	5	5
Elongation ¹⁾	[%]	0.105	0.1	0.122
Effective diameter	[mm]	28.65	39.79	52.52
Feed constant	[mm/rev]	90	125	165

1) At max. feed force

Mass moment of inertia		70	80	120
Size		70	80	120
J_0				
ELGA-...	[kg mm ²]	237	1062	4937
ELGA-...-S	[kg mm ²]	209	975	4554
ELGA-...-L	[kg mm ²]	282	1265	6008
J_H per metre stroke	[kg mm ² /m]	23	110	264
J_L per kg payload	[kg mm ² /kg]	205	396	690

The mass moment of inertia J_A of the entire axis is calculated as follows:

$$J_A = J_0 + J_H \times \text{working stroke [m]} + J_L \times m_{\text{payload [kg]}}$$

Materials

Sectional view

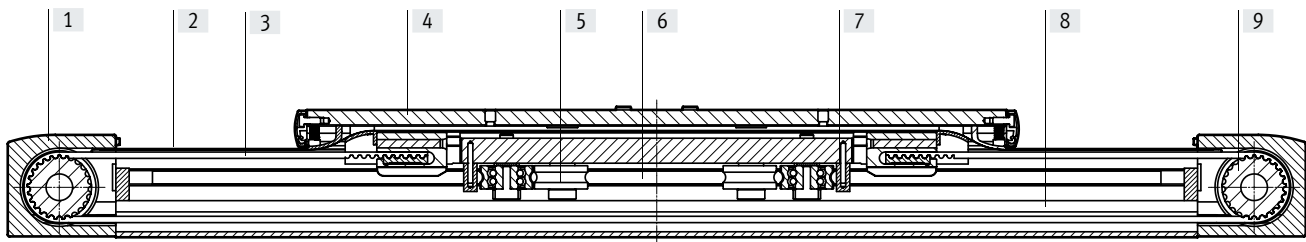

Axis		
[1]	Drive cover	Anodised wrought aluminium alloy
[2]	Cover strip	Stainless steel strip, non-corroding
[3]	Toothed belt	Polyurethane with steel cord
[4]	Slide	Anodised wrought aluminium alloy
[5]	Castor	Hardened rolled steel (lubricant approved for the food zone)
[6]	Guide rod	Hardened tempered steel
[7]	Scraper	Oil-impregnated felt (lubricating oil approved for the food zone)
[8]	Profile	Anodised wrought aluminium alloy
[9]	Toothed belt pulley	High-alloy stainless steel
Note on materials		RoHS-compliant
		Contains paint-wetting impairment substances

Data sheet – For the food zone

Characteristic load values

The indicated forces and torques refer to the slide surface. The point of application of force is the point where the centre of the guide and the longitudinal centre of the slide intersect. These values must not be exceeded during dynamic operation. Special attention must be paid to the cushioning phase.

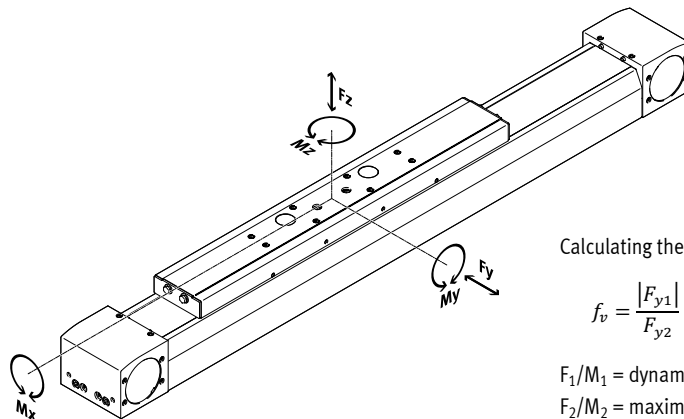

If the axis is subjected to two or more of the indicated forces and torques simultaneously, the following equation must be satisfied in addition to the indicated maximum loads:

Calculating the load comparison factor:

$$f_v = \frac{|F_{y1}|}{F_{y2}} + \frac{|F_{z1}|}{F_{z2}} + \frac{|M_{x1}|}{M_{x2}} + \frac{|M_{y1}|}{M_{y2}} + \frac{|M_{z1}|}{M_{z2}} \leq 1$$

F_1/M_1 = dynamic value

F_2/M_2 = maximum value

Max. permissible forces and torques for a service life of 10000 km				
Size		70	80	120
$F_{y_{max}}$	[N]	400	640	1600
$F_{z_{max}}$	[N]	400	640	1600
$M_{x_{max}}$	[Nm]	8.8	24	80
$M_{y_{max}}$				
ELGA-...	[Nm]	16	72	256
ELGA-...-S	[Nm]	16	72	256
ELGA-...-L	[Nm]	32	144	512
$M_{z_{max}}$				
ELGA-...	[Nm]	16	72	256
ELGA-...-S	[Nm]	16	72	256
ELGA-...-L	[Nm]	32	144	512

Calculating the service life

The service life of the guide depends on the load. To be able to make a statement as to the service life of the guide, the graph below plots the load comparison factor f_v against the service life.

These values are only theoretical. You must consult your local Festo contact for a load comparison factor f_v greater than 1.5.

Load comparison factor f_v as a function of service life

Example:

A user wants to move an X kg load. Using the formula (→ page 68) gives a value of 1.5 for the load comparison factor f_v . According to the graph, the guide would have a service life of approx. 3000 km. Reducing the acceleration reduces the M_z and M_y values. A load comparison factor f_v of 1 now gives a service life of 10000 km.

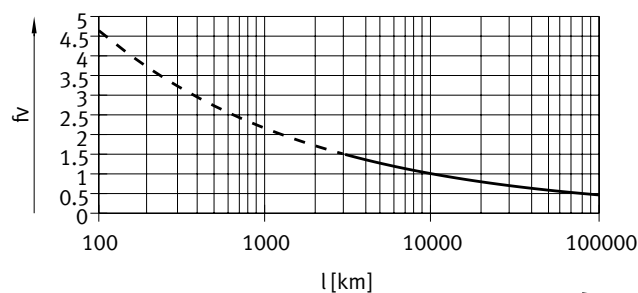

Note
Engineering software
PositioningDrives
www.festo.com

The software can be used to calculate a guide workload for a service life of 10000 km.

$f_v > 1.5$ are only theoretical comparison values for the roller bearing guide.

Data sheet – For the food zone

Max. acceleration a as a function of payload m

Size 70

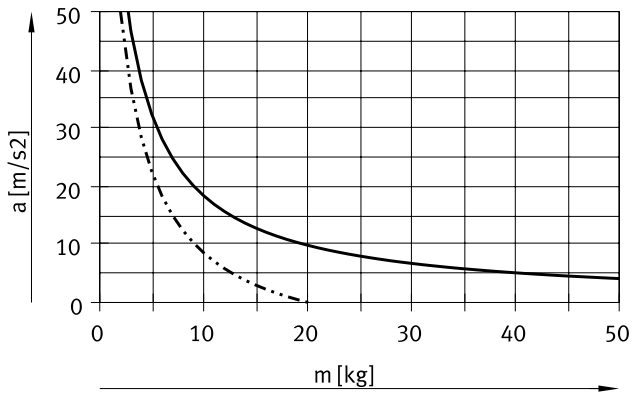

Size 80

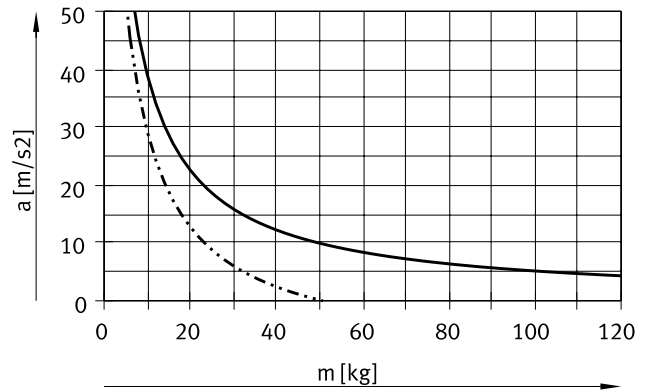

Size 120

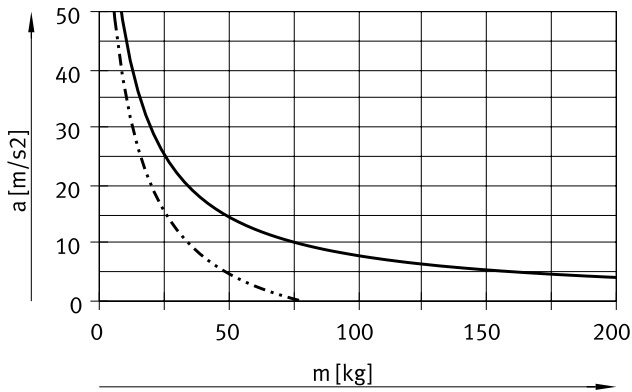

— Horizontal mounting position
- - - Vertical mounting position

Speed v as a function of rotational speed n

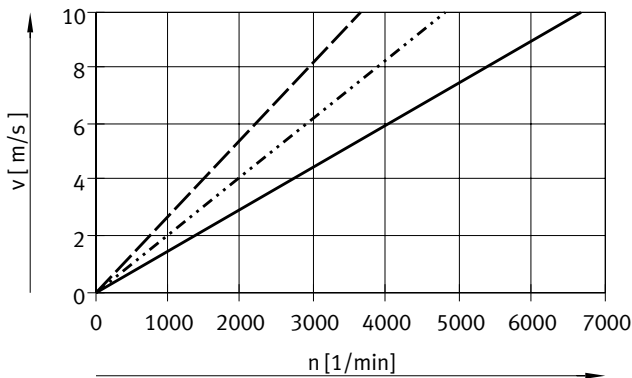

— ELGA-TB-RF-70
..... ELGA-TB-RF-80
- - - ELGA-TB-R-120

Data sheet – For the food zone

Theoretical feed force F as a function of input torque M

Size 70

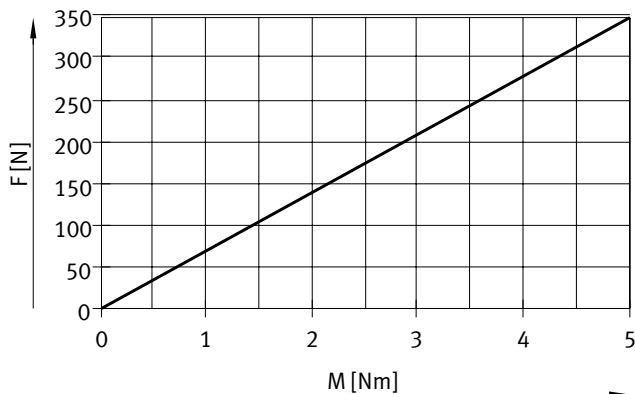

— ELGA-TB-RF-70

Size 80/120

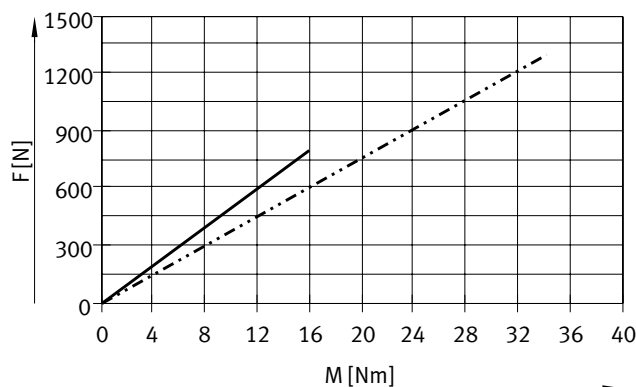

— ELGA-TB-RF-80
 - - - - - ELGA-TB-RF-120

Stroke reserve



L19 = Nominal stroke
 L20 = Stroke reserve

- The stroke reserve is a safety distance from the mechanical end position and is not used in normal operation
- The sum of the nominal stroke and 2x stroke reserve must not exceed the maximum permissible working stroke

- The stroke reserve length can be freely selected
- The stroke reserve is defined via the "stroke reserve" characteristic in the modular product system.

Example:

Type ELGA-TB-RF-70-500-20H-...
 Nominal stroke = 500 mm
 2x stroke reserve = 40 mm
 Working stroke = 540 mm
 (540 mm = 500 mm + 2x 20 mm)

Second moment of area

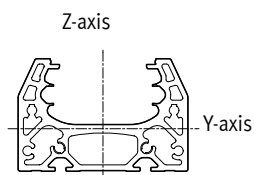

Size		70	80	120
ly	[mm ⁴]	1.48x10 ⁵	2.77x10 ⁵	1.32x10 ⁶
lz	[mm ⁴]	4.52x10 ⁵	1.00x10 ⁶	4.74x10 ⁶

Data sheet – For the food zone

Maximum permissible support spacing L (without central support EAHF) as a function of force F

In order to limit deflection in the case of large strokes, the axis may need to be supported.

The following graphs can be used to determine the maximum permissible support spacing l as a function of force F acting on the axis. The deflection is $f = 0.5$ mm.

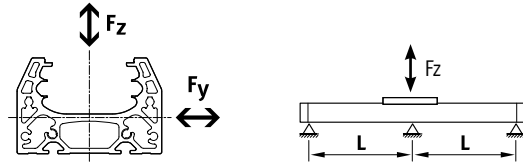
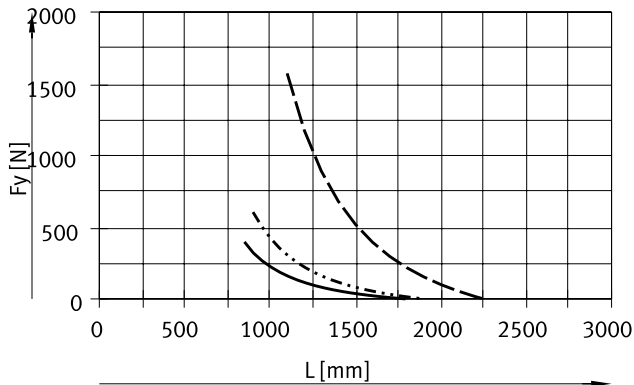
Force F_y 

- ELGA-TB-RF-70
- ELGA-TB-RF-80
- - - ELGA-TB-RF-120

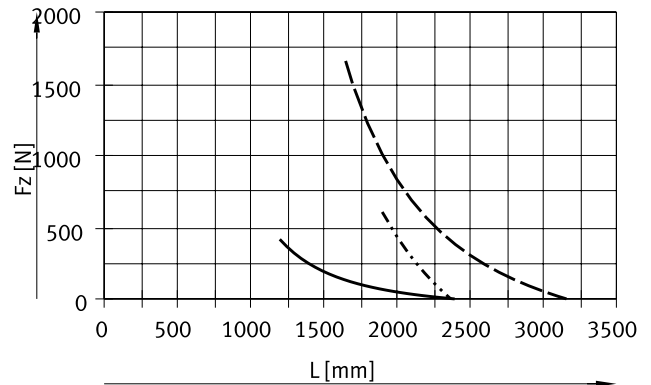
Force F_z **Recommended deflection limits**

Adherence to the following deflection limits is recommended so as not to impair the functionality of the axes.

Greater deformation can result in increased friction, greater wear and reduced service life.

Size	Dynamic deflection (moving load)	Static deflection (stationary load)
70 ... 120	0.05% of the axis length, max. 0.5 mm	0.1% of the axis length

Data sheet – For the food zone

Dimensions

Download CAD data → www.festo.com

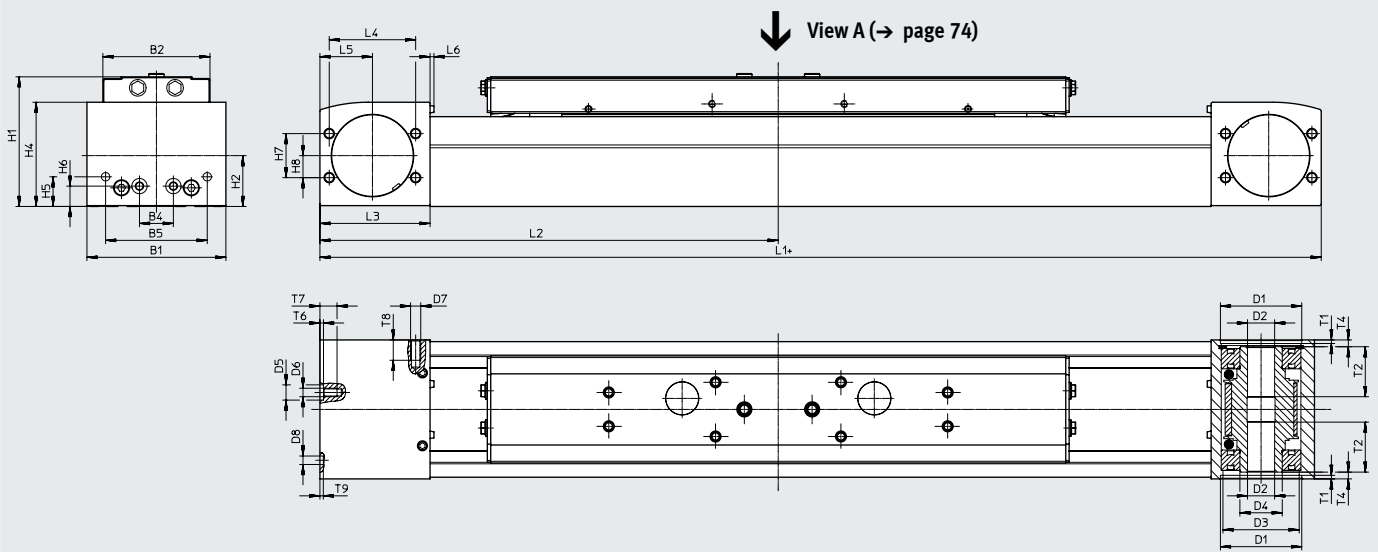

Size	B1	B2	B4	B5	D1 ∅ H7	D2 ∅ H7	D3 ∅	D4 ∅	D5 ∅ H7	D6
70	69	48.2	30	45	38	16	34	25	–	M5
80	82	63.2	20	60	48	16	45	25	9	M5
120	120	95	80	40	80	23	72	45	–	M8

Size	D7	D8 ∅ H7	H1	H2	H4	H5	H6	H7	H8	L3
70	M6	5	64	26.5	50.8	13	13	24	12	57.5
80	M6	5	76.5	30	61.5	17.5	12	26	13	65
120	M8	9	111.5	45	91	22	22	59	32	100

Size	L4	L5	L6	T1	T2	T4	T6	T7	T8	T9
70	42	27.5	2.3	2.1	18	7.15	–	10	12	3.1
80	51	31	2.3	2.1	29.5	4	2.1	10.1	12	2
120	76	50	2.5	3.1	29.5	4	–	16	16	2.1

Size Slide design	L1			L2		
	ELGA-...	ELGA-...-S	ELGA-...-L	ELGA-... min.	ELGA-...-S min.	ELGA-...-L min.
70	420	342	520	210	171	260
80	580	496	720	290	248	360
120	775	673	1005	387.5	336.5	502.5

Data sheet – For the food zone

Dimensions

Download CAD data → www.festo.com

Profile

Size 70

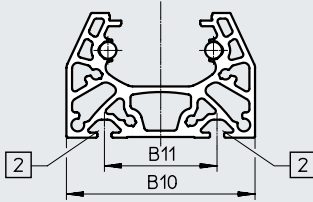

Size 80

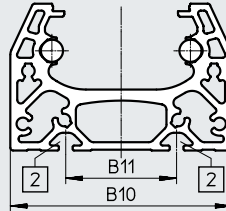

Size 120

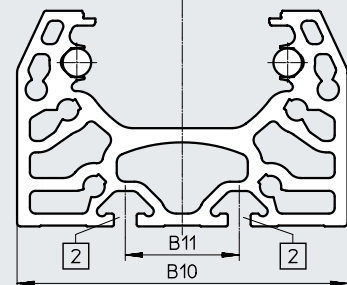

[3] Mounting slot for slot nut:
 for size 70, 80: slot nut NST-5-M5
 for size 120: slot nut NST-8-M6

Size	B10	B11
70	67	40
80	80	40
120	116	40

**Note**

Requirements for the flatness of the bearing surface and of attachments as well as for use in parallel structures

→ www.festo.com/sp

User documentation

Data sheet – For the food zone

Dimensions

Download CAD data → www.festo.com

ELGA... – Standard slide

Size 70

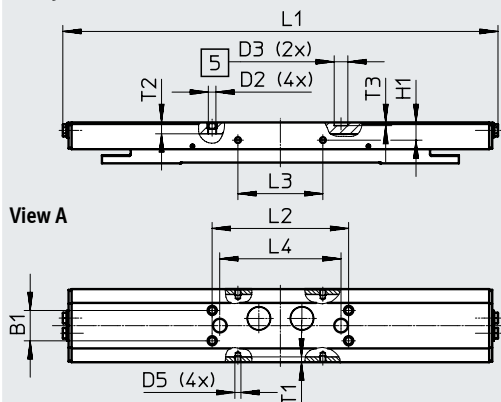

Size 80

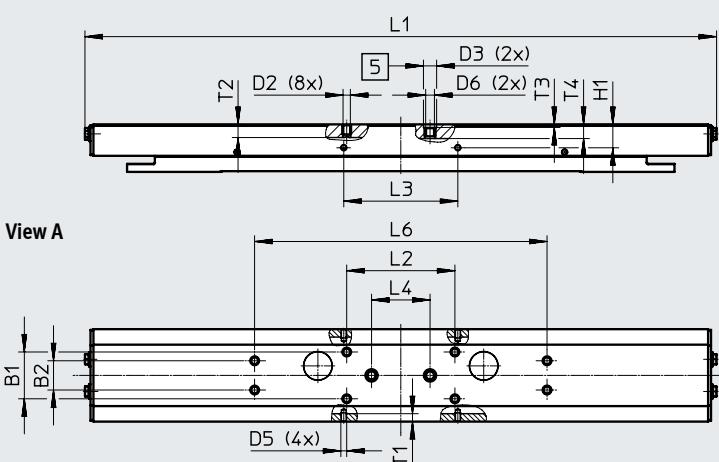

Size 120

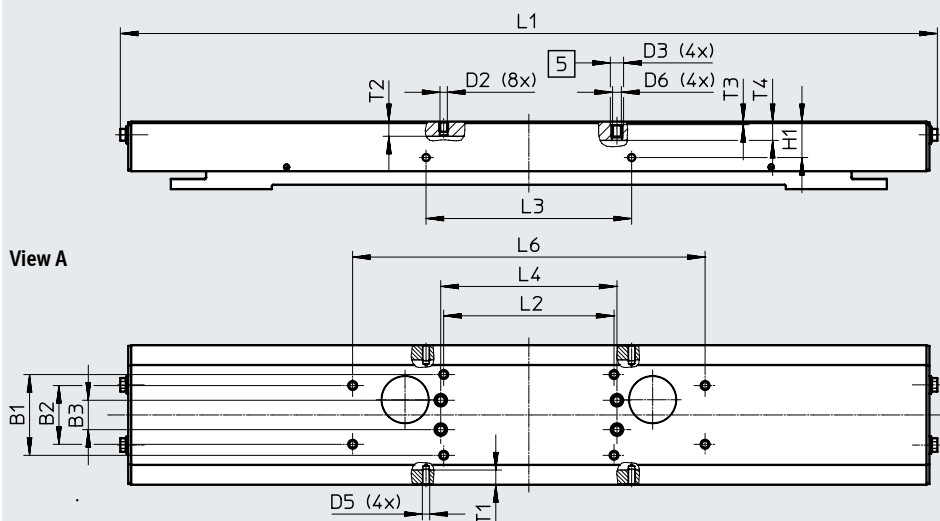

[5] Drill hole for centring sleeve

Size	B1	B2	B3	D2	D3 ∅ H7	D5	D6	H1
	±0.1	±0.1	±0.1					±0.1
70	20	-	-	M5	9	M4	-	11.7
80	32	20	-	M5	9	M4	M6	16
120	55	40	20	M5	9	M5	M6	24.5

Size	L1	L2	L3	L4	L6	T1	T2	T3	T4
		±0.2	±0.1	±0.03	±0.2				
70	287	90	56	80	-	3.5	7.5	2.1	-
80	432	74	78	40	200	5.1	9	2.1	9.7
120	556.4	116	140	120	240	10	10	2.1	12.8

Data sheet – For the food zone

Dimensions

Download CAD data → www.festo.com

ELGA-...S – Short slide

Size 70

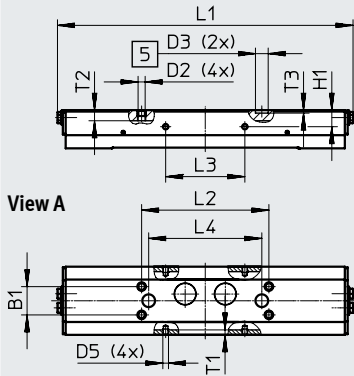

Size 80

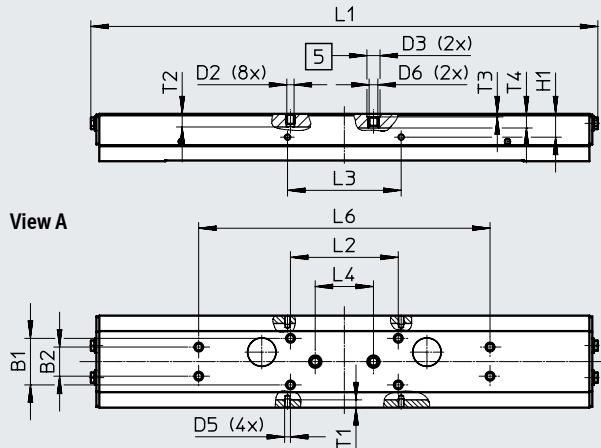

Size 120

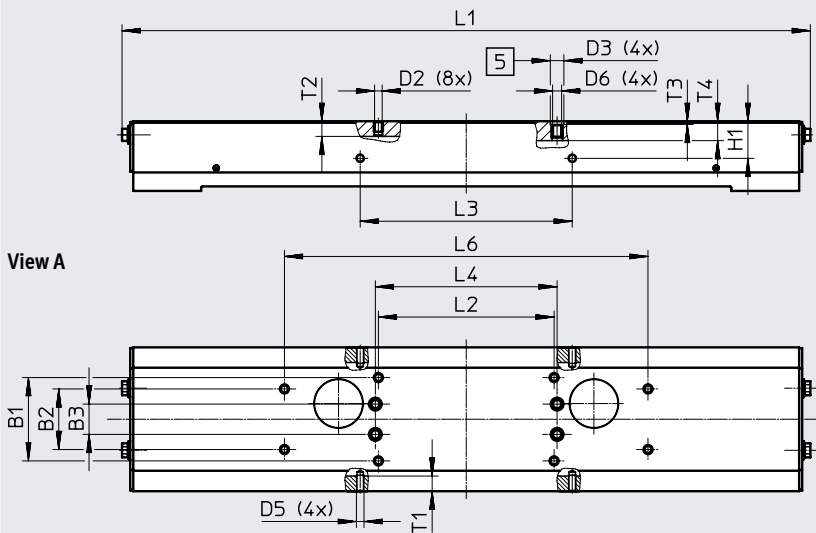

[5] Drill hole for centring sleeve

Size	B1	B2	B3	D2	D3 ∅ H7	D5	D6	H1
	±0.1	±0.1	±0.1					±0.1
70	20	-	-	M5	9	M4	-	11.7
80	32	20	-	M5	9	M4	M6	16
120	55	40	20	M5	9	M5	M6	24.5

Size	L1	L2	L3	L4	L6	T1	T2	T3	T4
		±0.2	±0.1	±0.03	±0.2				
70	209	90	56	80	-	3.5	7.5	2.1	-
80	348	74	78	40	200	5.1	9	2.1	9.7
120	454.4	116	140	120		10	10	2.1	12.8

Data sheet – For the food zone

Dimensions

Download CAD data → www.festo.com

ELGA...-L – Long slide

Size 70

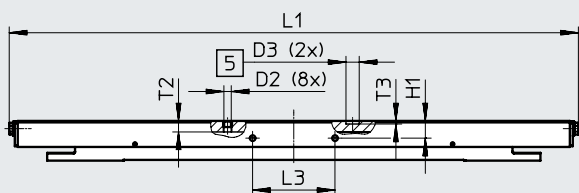

View A

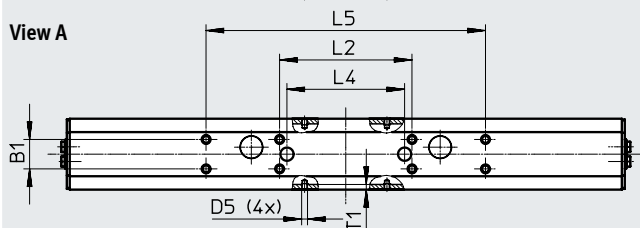

Size 80

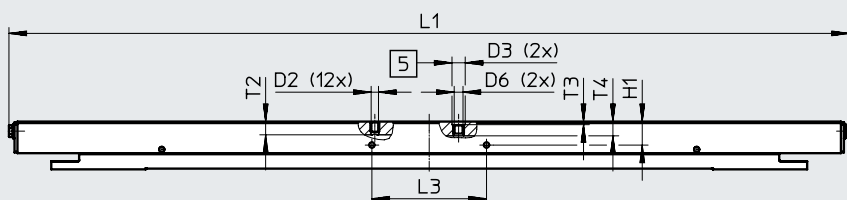

View A

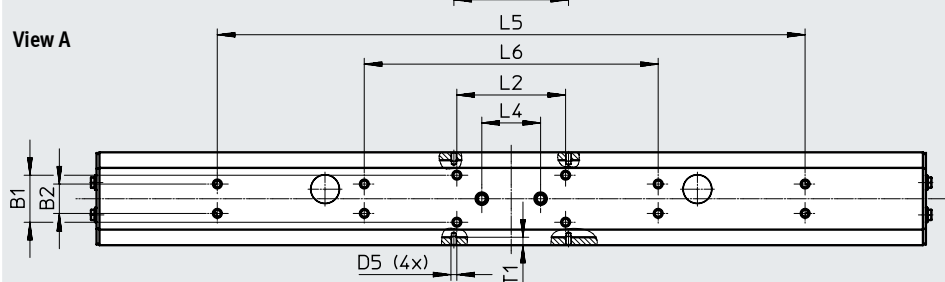

Size 120

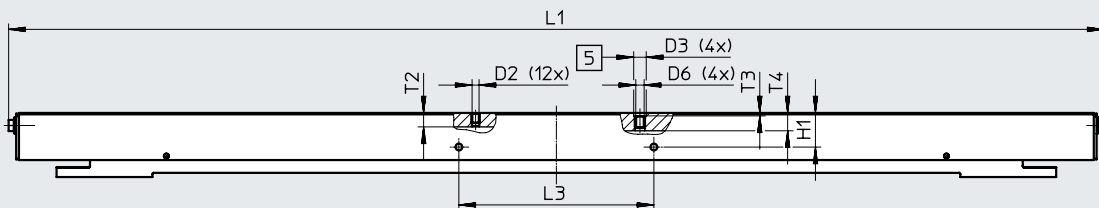

View A

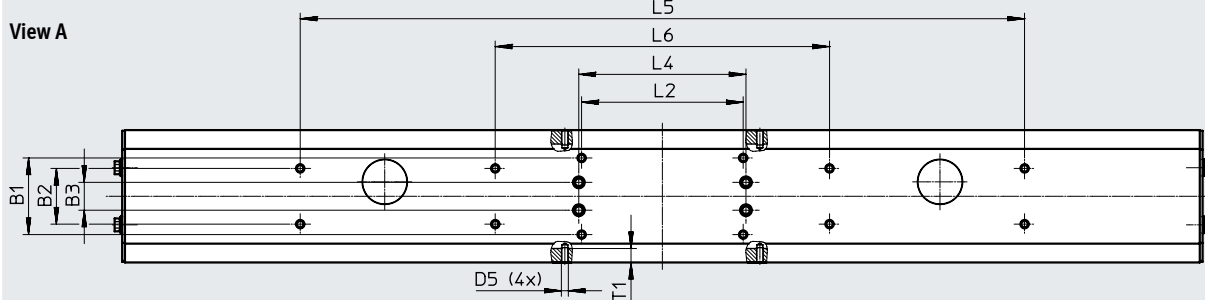

[5] Drill hole for centring sleeve

Data sheet – For the food zone

Size	B1 ±0.1	B2 ±0.1	B3 ±0.1	D2	D3 ∅ H7	D5
70	20	–	–	M5	9	M4
80	32	20	–	M5	9	M4
120	55	40	20	M5	9	M5

Size	D6	H1 ±0.1	L1	L2 ±0.2	L3 ±0.1	L4 ±0.03
70	–	11.7	387	90	56	80
80	M6	16	572	74	78	40
120	M6	24.5	786.4	116	140	120

Size	L5 ±0.2	L6 ±0.2	T1	T2	T3	T4
70	190	–	3.5	7.5	2.1	–
80	400	200	5.1	9	2.1	9.7
120	520	240	10	10	2.1	12.8

Ordering data – Modular products – For the food zone

Accessories

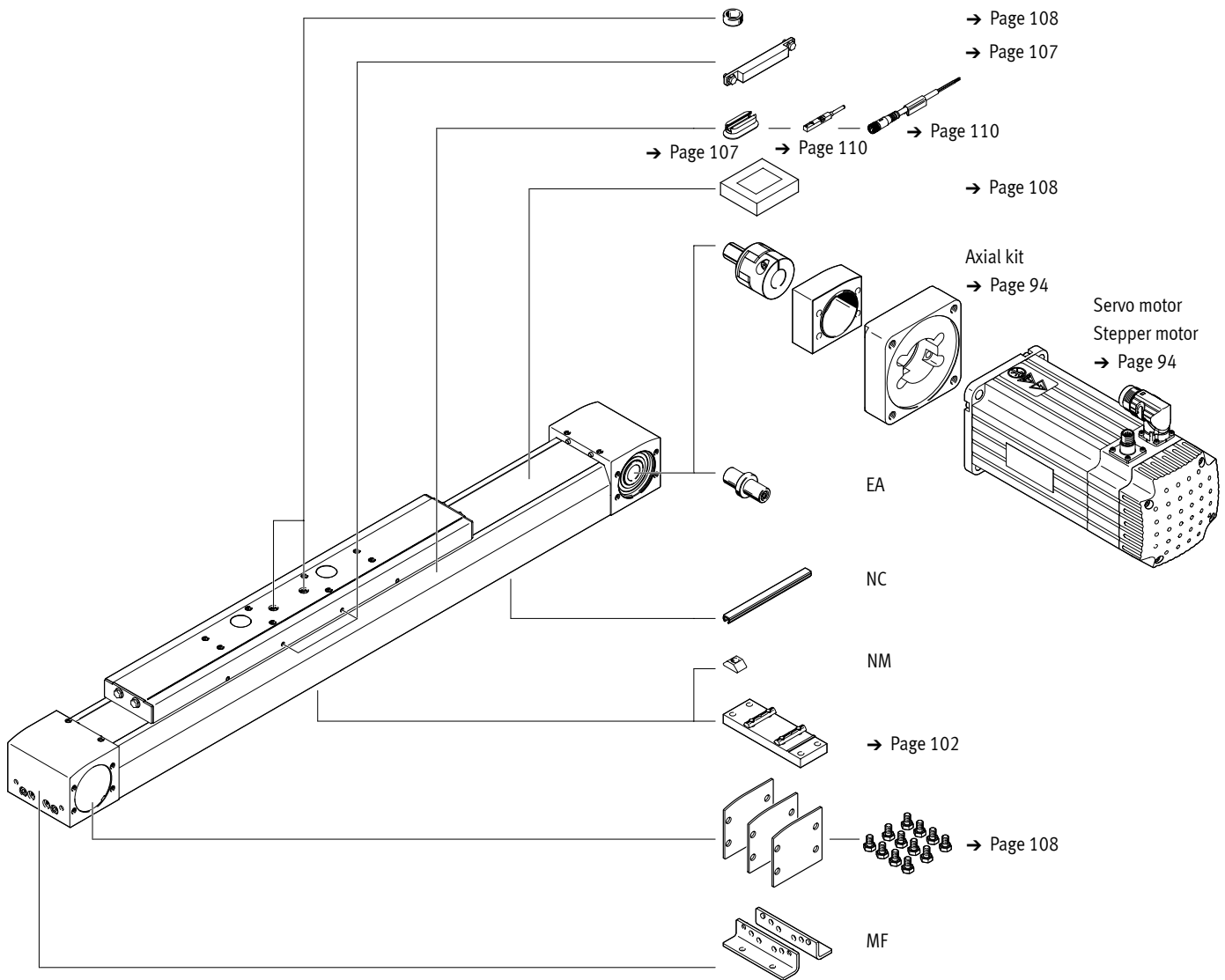

Ordering data – Modular products – For the food zone

Ordering table						
Size	70	80	120	Conditions	Code	Enter code
Module no.	1371245	1371246	1371247			
Design	Linear axis				ELGA	ELGA
Function	Toothed belt				-TB	-TB
Guide	Roller guide				-RF	-RF
Size [mm]	70	80	120		-...	
Stroke length [mm]	1 ... 7000	1 ... 7000	1 ... 7400		-...	
Stroke reserve [mm]	0 ... 999 (0 = no stroke reserve)			[1]	-...H	
Slide design	Standard slide					
	1 ... 7000	1 ... 7000	1 ... 7400			
	Short slide			[2]	-S	
	1 ... 7000	1 ... 7000	1 ... 7400			
	Long slide				-L	
	1 ... 6900	1 ... 6900	1 ... 7200			
Protection against particles	Standard					
	Without cover strip				-P0	
Additional features	Food-safe as per supplementary material information				-F1	-F1
Material of toothed belt	Uncoated PU				-PU1	-PU1
Accessories	Accessories enclosed separately				+	+
Foot mounting	1				MF	
Mounting slot cover	1 ... 50 (1 = 2 units, 500 mm)				...NC	
Slot nut for mounting slot	1 ... 99				...NM	
Drive shaft	1 ... 4				...EA	
Operating instructions	With operating instructions					
	Without operating instructions				-DN	

[1] ... **H** The sum of the nominal stroke and 2x stroke reserve must be at least 50 mm and must not exceed the maximum stroke length

[2] **S** Only with P0

Peripherals overview

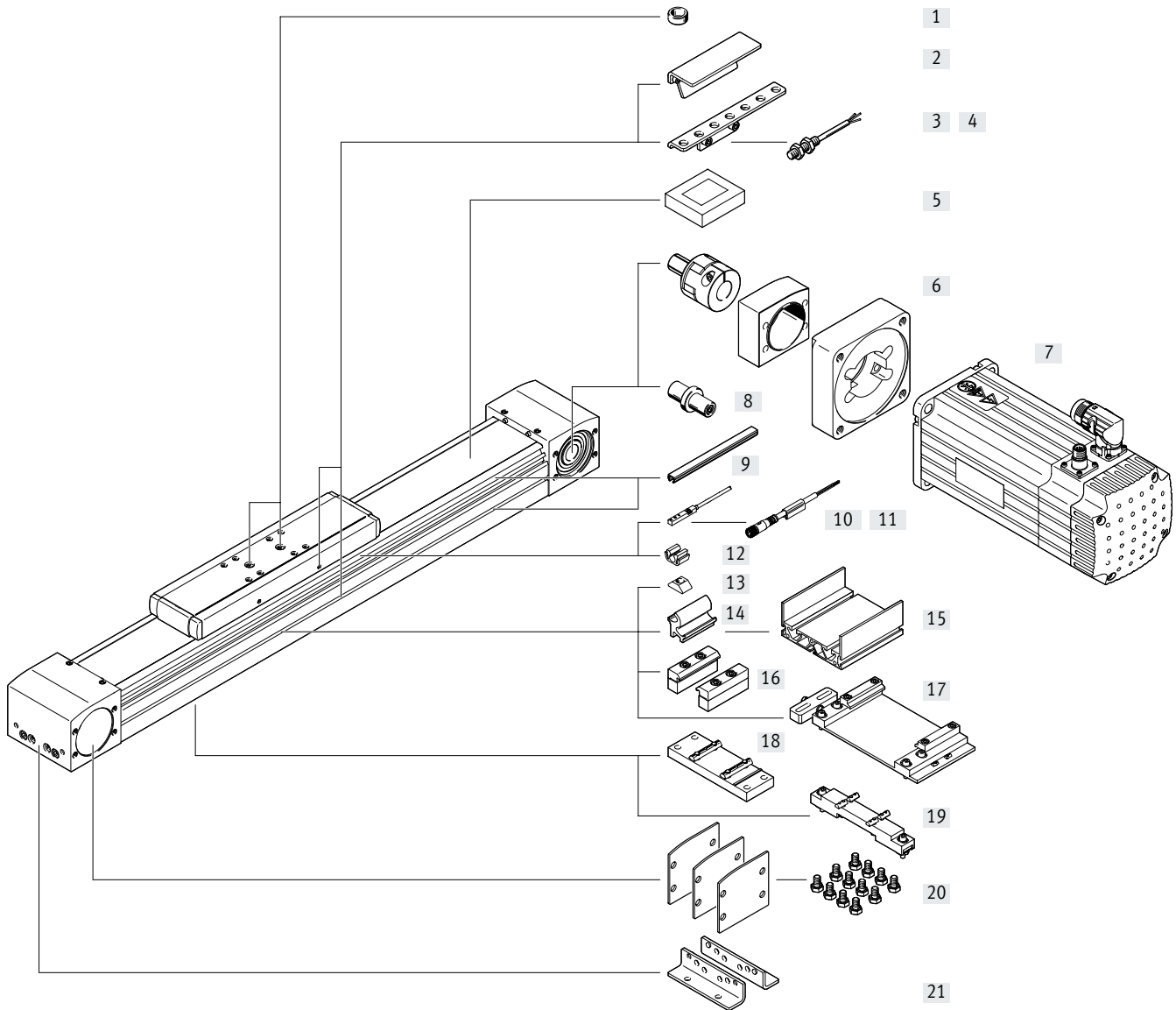
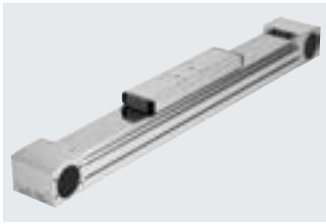

Peripherals overview

Accessories			
	Type/order code	Description	→ Page/Internet
[1]	Centring pin/sleeve ZBS, ZBH	<ul style="list-style-type: none"> For centring loads and attachments on the slide Included in the scope of delivery: <ul style="list-style-type: none"> For size 70: 2x ZBS-5 For size 80, 120: 2x ZBH-9 	108
[2]	Switch lug SA, SB, SC, SD, SE, SF	For sensing the slide position	105
[3]	Sensor bracket SC, SD, SE, SF	For mounting the inductive proximity switches (round design) on the axis	106
[4]	Proximity switch, M8 SC, SD, SE, SF	<ul style="list-style-type: none"> Inductive proximity switch, round design The order code SC, SD, SE, SF includes 1 switch lug and max. 2 sensor brackets in the scope of delivery 	110
[5]	Clamping element EADT	Tool for retensioning the cover strip	108
[6]	Axial kit EAMM	For axial motor mounting (comprises: coupling, coupling housing and motor flange)	94
[7]	Motor EMME, EMMS	Motors specially matched to the axis, with or without gear unit, with or without brake	94
[8]	Drive shaft EA	<ul style="list-style-type: none"> Can, if required, be used as an alternative interface No drive shaft is required for the axis/motor combinations → page 94 	99
[9]	Slot cover NS, NC	For protection against contamination	108
[10]	Proximity switch, T-slot SA, SB	<ul style="list-style-type: none"> Inductive proximity switch, for T-slot The order code SA, SB includes 1 switch lug in the scope of delivery 	109
[11]	Connecting cable CA	For proximity switch (order code SE and SF)	110
[12]	Clip CM	For mounting the proximity switch cable in the slot	108
[13]	Slot nut NM	For mounting attachments	108
[14]	Adapter kit DHAM	For mounting the support profile on the axis	109
[15]	Support profile HMIA	For mounting and guiding an energy chain	109
[16]	Profile mounting MA	For mounting the axis on the side of the profile	101
[17]	Adjusting kit EADC-E16	For mounting the axis on a vertical surface. Once mounted, the axis can be aligned horizontally	104
[18]	Central support EAHF-L5	For mounting the axis on the profile from underneath	102
[19]	Adjusting kit EADC-E15	Is height-adjustable. Can be used to easily compensate for any unevenness in the bearing surface	103
[20]	Cover kit EASC-L5	For covering the sides of the drive cover	108
[21]	Foot mounting MF	<ul style="list-style-type: none"> For mounting the axis on the end cap With higher forces and torques, the axis should be mounted using the profile 	100

Type codes

001	Series	
ELGA	Gantry axis	

002	Drive system	
TB	Toothed belt	

003	Guide	
G	Basic variant	

004	Size	
70	70	
80	80	
120	120	

005	Stroke	
...	50 ... 8500	

006	Stroke reserve [mm]	
...H	0 ... 999	

007	Protection against particles	
	Standard	
P0	Without strip cover	

008	Toothed belt material	
	Standard	
PU2	Coated PU	

009	Foot mounting [units]	
	None	
MF	1	

010	Profile mounting	
	None	
...MA	1 ... 50	

011	Proximity sensor, inductive, slot 8, PNP, N/O contact, cable 7.5 m [units]	
	None	
...SA	1 ... 6	

012	Proximity sensor, inductive, slot 8, PNP, N/C contact, cable 7.5 m [units]	
	None	
...SB	1 ... 6	

013	Proximity sensor, inductive, M8, PNP, N/O contact, cable 2.5 m [units]	
	None	
...SC	1 ... 99	

014	Proximity sensor, inductive, M8, PNP, N/C contact, cable 2.5 m [units]	
	None	
...SD	1 ... 99	

015	Proximity sensor, inductive, M8, PNP, N/O contact, plug M8 [units]	
	None	
...SE	1 ... 99	

016	Proximity sensor, inductive, M8, PNP, N/C contact, plug M8 [units]	
	None	
...SF	1 ... 99	

017	Connecting cable, M8, 2.5 m [units]	
	None	
...CA	1 ... 99	

018	Cover, sensor slot [units]	
	None	
...NS	1 ... 50	

019	Mounting slot cover, 2x, 500 mm [units]	
	None	
...NC	1 ... 50	

020	Slot nut for mounting slot	
	None	
...NM	1 ... 99	



021	Cable clip [units]	
	None	
...CM	10, 20, 30, 40, 50, 60, 70, 80, 90	

022	Drive shaft [units]	
	None	
...EA	1 ... 4	

023	Operating instructions	
	With operating instructions	
DN	Without operating instructions	

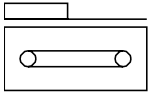
Data sheet

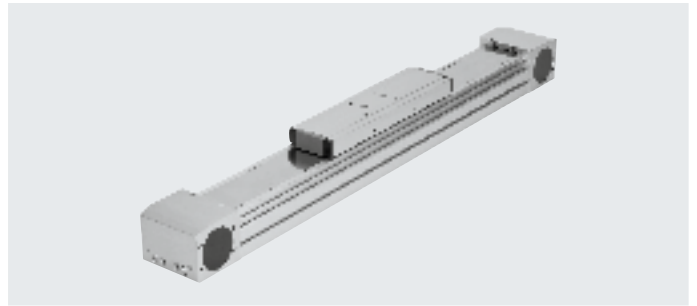

-  Size
70 ... 120
-  Stroke length
50 ... 8500 mm
-  www.festo.com

**General technical data**

Size	70	80	120
Design	Electromechanical axis with toothed belt		
Guide	Plain-bearing guide		
Mounting position	Any		
Working stroke	[mm] 50 ... 8500	50 ... 8500	50 ... 8500
Max. feed force F_x	[N] 350	800	1300
Max. no-load torque ¹⁾	[Nm] 0.5	1	3
Max. no-load resistance to shifting ¹⁾	[N] 35	50	114
Max. driving torque	[Nm] 5	15.9	34.1
Max. speed ²⁾	[m/s] 5		
Max. acceleration	[m/s ²] 50		
Repetition accuracy	[mm] ±0.08		

1) At 0.2 m/s

2) At higher speeds, the wear on the guide will increase

Operating and environmental conditions

Ambient temperature ¹⁾	[°C]	-10 ... +60
Degree of protection		
ELGA-...		IP40
ELGA-...-P0		IP00
Duty cycle	[%]	100

1) Note operating range of proximity switches

Weight [kg]

Size	70	80	120
Basic weight with 0 mm stroke (including slide)	2.16	4	11.8
Additional weight per 1000 mm stroke	2.64	3.56	7.45
Moving mass	0.57	1.1	3.06

Toothed belt

Size	70	80	120
Pitch	[mm] 3	5	5
Elongation ¹⁾			
ELGA-...	[%] 0.213	0.168	0.21
ELGA-...-PU2	[%] 0.105	0.1	0.122
Effective diameter	[mm] 28.65	39.79	52.52
Feed constant	[mm/rev] 90	125	165

1) At max. feed force

Mass moment of inertia

Size	70	80	120
J_0	[kg mm ²] 175	666	3201
J_H per metre stroke	[kg mm ² /m] 19	93	215
J_L per kg payload	[kg mm ² /kg] 205	396	690

The mass moment of inertia J_A of the entire axis is calculated as follows:

$$J_A = J_0 + J_H \times \text{working stroke [m]} + J_L \times m_{\text{payload [kg]}}$$

Data sheet

Materials

Sectional view

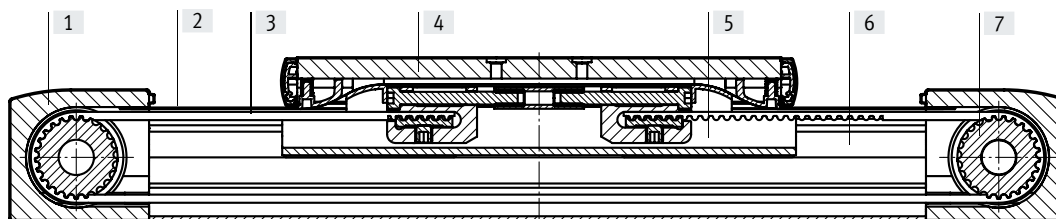

Axis		
[1]	Drive cover	Anodised wrought aluminium alloy
[2]	Cover strip	Stainless steel strip, non-corroding
[3]	Toothed belt	
	ELGA-...	Polychloroprene with glass cord and nylon coating
	ELGA-...-PU2	Polyurethane with steel cord and nylon covering
[4]	Slide	Anodised wrought aluminium alloy
[5]	Slide elements	Polyacetal
[6]	Profile with integrated guide	Anodised wrought aluminium alloy
[7]	Toothed belt pulley	High-alloy stainless steel
	Note on materials	RoHS-compliant
		Contains paint-wetting impairment substances

Characteristic load values

The indicated forces and torques refer to the slide surface. The point of application of force is the point where the centre of the guide and the longitudinal centre of the slide intersect.

These values must not be exceeded during dynamic operation. Special attention must be paid to the deceleration phase.

In the event of high torques M_y and M_z , the guide may lock automatically during dynamic operation. Therefore, make sure that the feed force is applied as close as possible to the slide.

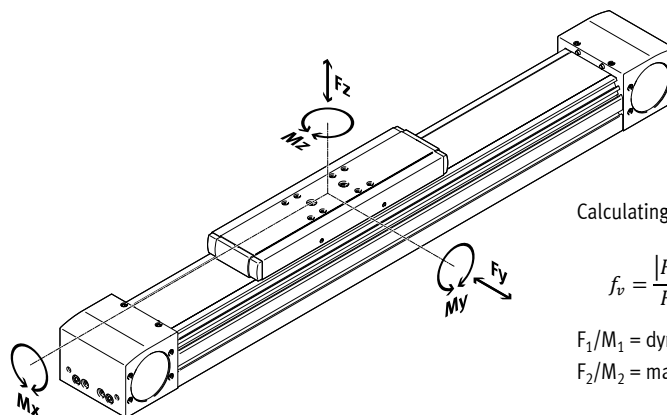

If the axis is subjected to two or more of the indicated forces and torques simultaneously, the following equation must be satisfied in addition to the indicated maximum loads:

Calculating the load comparison factor:

$$f_v = \frac{|F_{y1}|}{F_{y2}} + \frac{|F_{z1}|}{F_{z2}} + \frac{|M_{x1}|}{M_{x2}} + \frac{|M_{y1}|}{M_{y2}} + \frac{|M_{z1}|}{M_{z2}} \leq 1$$

F_1/M_1 = dynamic value

F_2/M_2 = maximum value

Permissible forces and torques

Size		70	80	120
$F_{y_{max}}$	[N]	80	200	380
$F_{z_{max}}$	[N]	400	800	1600
$M_{x_{max}}$	[Nm]	5	10	20
$M_{y_{max}}$	[Nm]	30	60	120
$M_{z_{max}}$	[Nm]	10	20	40

The plain-bearing guide is subject to wear. This depends on the load, on the travel speed and on the length of the pause between the travel cycles. A higher speed has a more critical effect on wear than a higher load. The values given above refer to a maximum travel speed of 0.5 m/s and a pause longer than 5 s.

The plain-bearing guide is not backlash-free. The toothed belt axis ELGA-TB-RF or ELGA-TB-KF is recommended for applications that need to be backlash-free, or applications involving high torque loads.

Engineering software
PositioningDrives
www.festo.com

Data sheet

Max. acceleration a as a function of payload m

Size 70

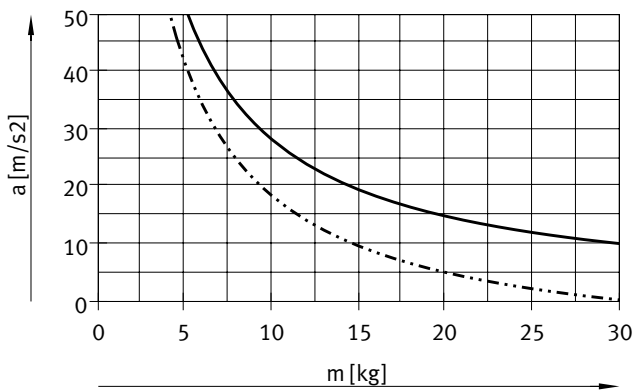

Size 80

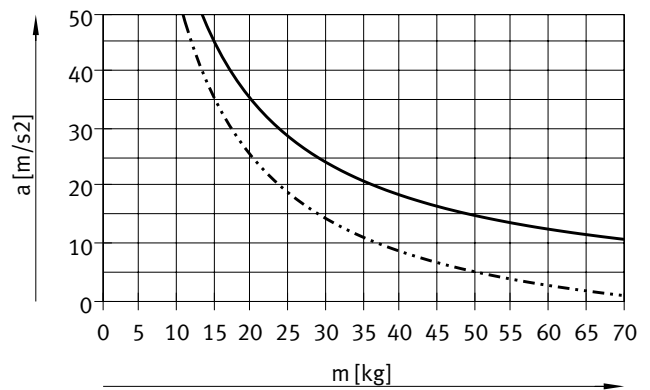

Size 120

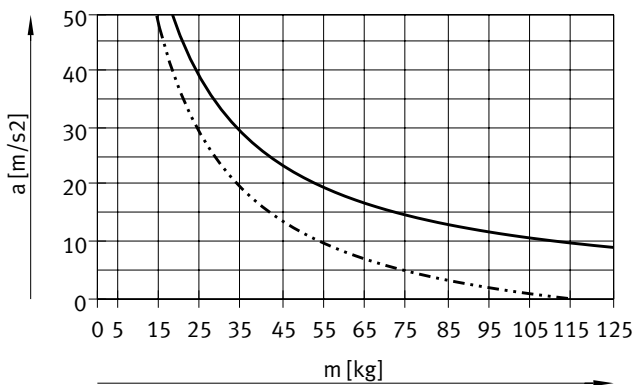

— Horizontal mounting position
 - - - Vertical mounting position

Speed v as a function of rotational speed n

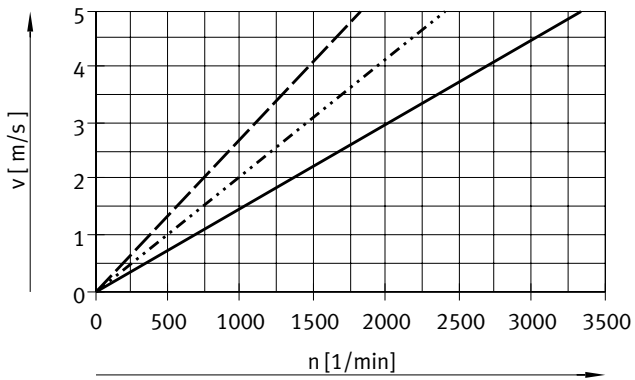

— ELGA-TB-G-70
 ELGA-TB-G-80
 - - - ELGA-TB-G-120

Data sheet

Theoretical feed force F as a function of input torque M

Size 70

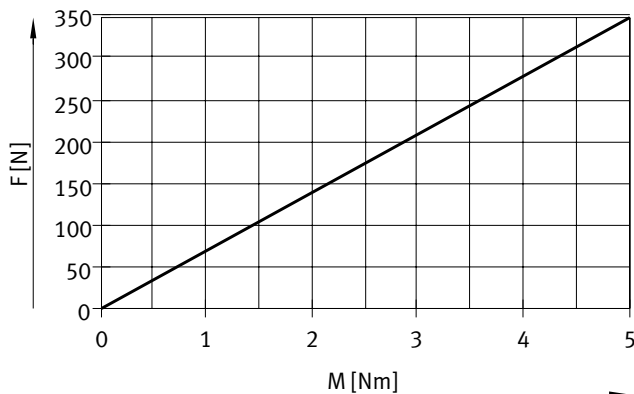

— ELGA-TB-G-70

Size 80/120

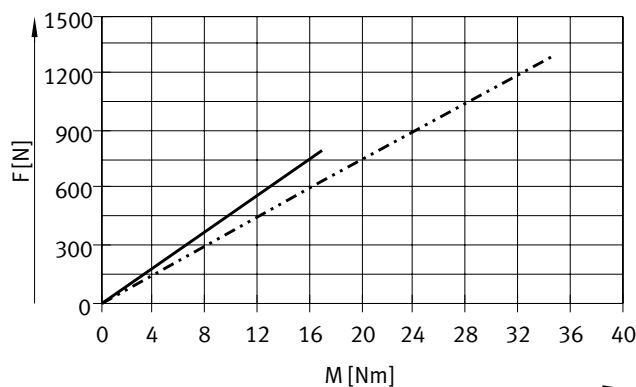

— ELGA-TB-G-80
 - - - ELGA-TB-G-120

Stroke reserve

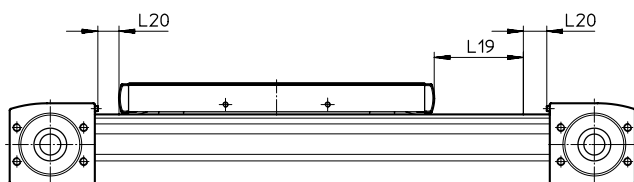

L19 = Nominal stroke
 L20 = Stroke reserve

- The stroke reserve is a safety distance from the mechanical end position and is not used in normal operation
- The sum of the nominal stroke and 2x stroke reserve must not exceed the maximum permissible working stroke
- The stroke reserve length can be freely selected
- The stroke reserve is defined via the "stroke reserve" characteristic in the modular product system.

Example:

Type ELGA-TB-G-70-500-20H-...
 Nominal stroke = 500 mm
 2x stroke reserve = 40 mm
 Working stroke = 540 mm
 (540 mm = 500 mm + 2x 20 mm)

The toothed belt axis ELGA-TB-G features a safety distance to the end positions as standard.

Size		70	80	120
Safety distance per end position	[mm]	4.5	5	5

Second moment of area

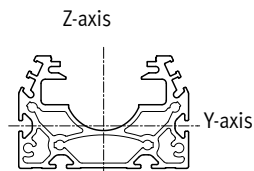

Size		70	80	120
I_y	[mm ⁴]	1.47×10^5	2.77×10^5	1.23×10^6
I_z	[mm ⁴]	4.25×10^5	9.07×10^5	4.03×10^6

Data sheet

Maximum permissible support spacing L (without profile mounting MUE/central support EAHF) as a function of force F

In order to limit deflection in the case of large strokes, the axis may need to be supported.

The following graphs can be used to determine the maximum permissible support spacing l as a function of force F acting on the axis. The deflection is $f = 0.5$ mm.

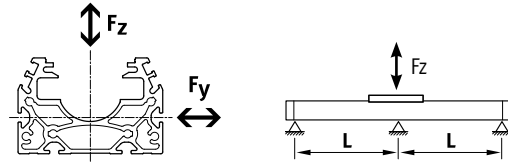

Force F_y

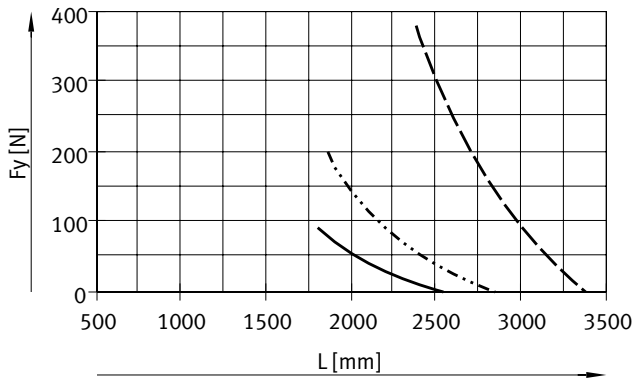

- ELGA-TB-G-70
- ELGA-TB-G-80
- - - ELGA-TB-G-120

Force F_z

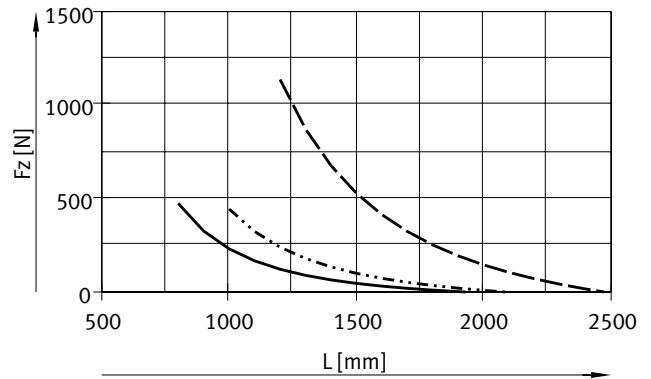

Recommended deflection limits

Adherence to the following deflection limits is recommended so as not to impair the functionality of the axes. Greater deformation can result in increased friction, greater wear and reduced service life.

Size	Dynamic deflection (moving load)	Static deflection (stationary load)
70 ... 120	0.05% of the axis length, max. 0.5 mm	0.1% of the axis length

Data sheet

Dimensions

Download CAD data → www.festo.com

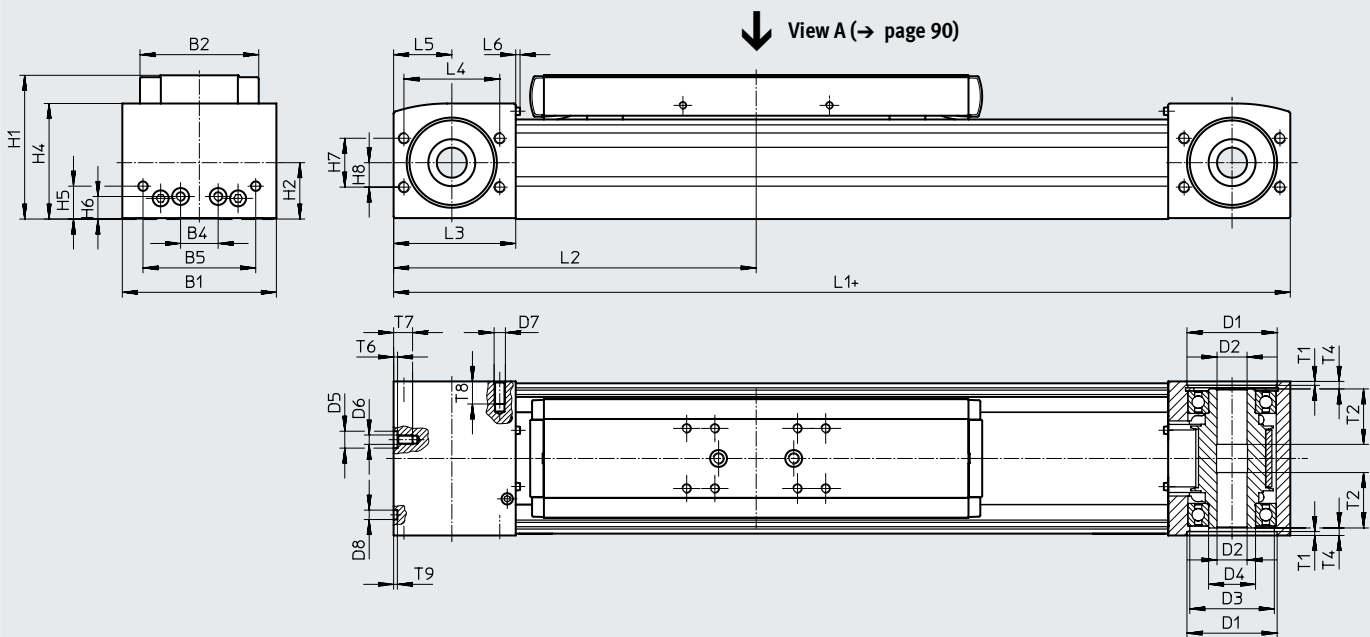

+ = plus stroke length + 2x stroke reserve

Size	B1	B2	B4	B5	D1 ∅ H7	D2 ∅ H7	D3 ∅	D4 ∅	D5 ∅ H7	D6	D7
70	69	48.2	30	45	38	16	34	25	-	M5	M6
80	82	63.2	20	60	48	16	45	25	9	M5	M6
120	120	95	80	40	80	23	72	45	-	M8	M8

Size	D8 ∅ H7	H1	H2	H4	H5	H6	H7	H8	L1	L2 min.	L3
70	5	64	26.5	50.8	13	13	24	12	346	173	57.5
80	5	76.5	30	61.5	17.5	12	26	13	386	193	65
120	9	111.5	45	91	22	22	59	32	546	273	100

Size	L4	L5	L6	T1	T2	T4	T6	T7	T8	T9
70	42	27.5	2.3	2.1	18	7.15	-	10	12	3.1
80	51	31	2.3	2.1	29.5	4	2.1	10	12	2
120	76	50	2.5	3.1	29.5	4	-	16	16	2.1

Data sheet

Dimensions

Download CAD data → www.festo.com

Profile

Size 70

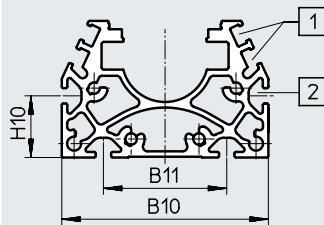

Size 80

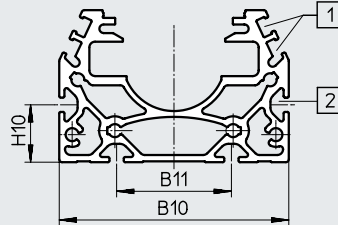

Size 120

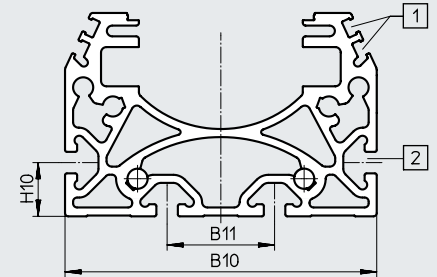

- [1] Sensor slot for proximity switch
 [2] Mounting slot for slot nut:
 for size 70, 80: slot nut NST-5-M5
 for size 120: slot nut NST-8-M6

Size	B10	B11	H10
70	67	40	20
80	80	40	20
120	116	40	20

 **Note**

Requirements for the flatness of the bearing surface and of attachments as well as for use in parallel structures

→ www.festo.com/sp

User documentation

Data sheet

Dimensions

Download CAD data → www.festo.com

Slide

Size 70

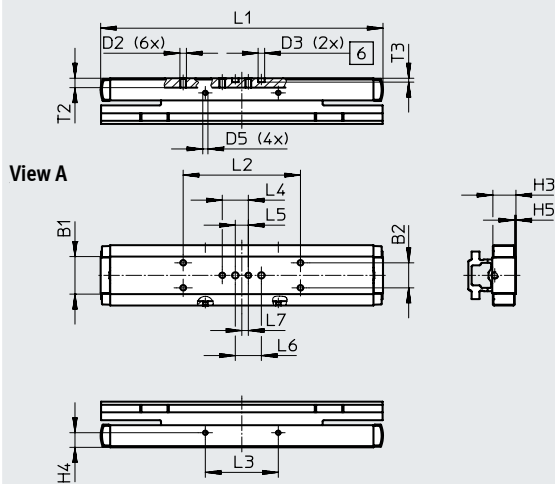

Size 80

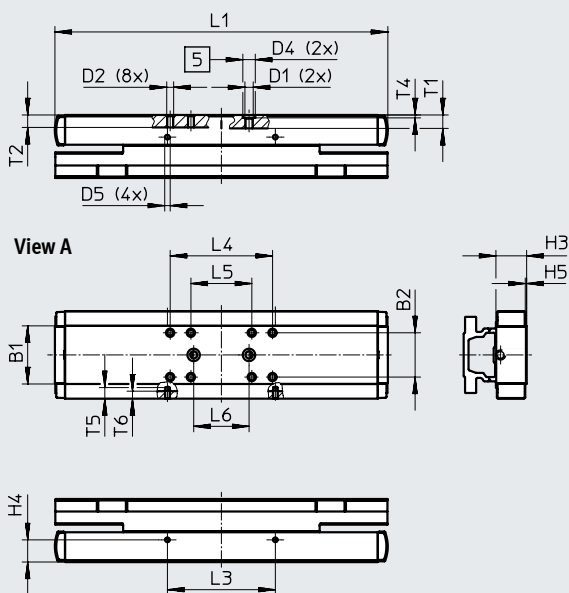

Size 120

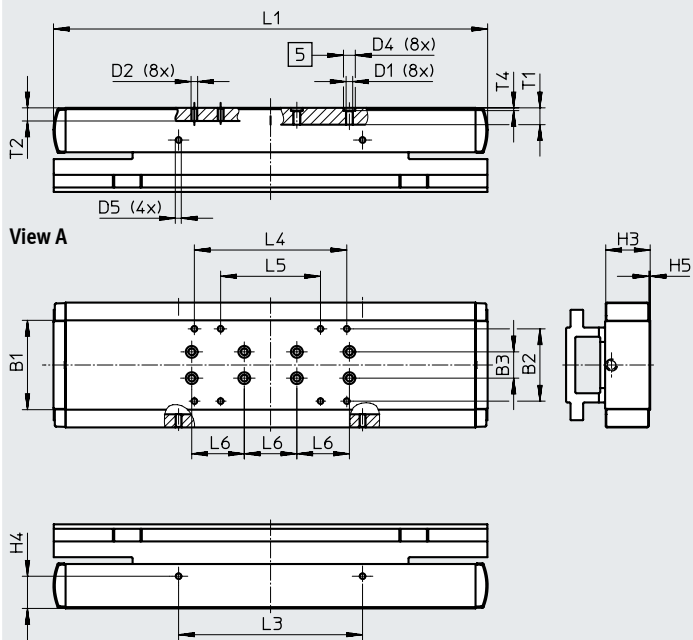

- [5] Drill hole for centring sleeve
- [6] Drill hole for centring pin

Data sheet

Size	B1	B2	B3	D1	D2	D3 ∅	D4 ∅	D5
70	30	20±0.1	–	–	M5	5 ^{H7}	–	M4
80	42	32±0.2	–	M6	M5	–	9 ^{H7}	M4
120	68	55±0.2	20±0.03	M6	M5	–	9 ^{H7}	M5

Size	H3	H4 ±0.1	H5	L1	L2 ±0.1	L3 ±0.1	L4	L5
70	17.7	11.7	1	216.6	90	56	20±0.1	10±0.1
80	22.2	16	1	240.6	–	78	74±0.2	44±0.2
120	33.8	24.5	1	330.4	–	140	116±0.2	76±0.2

Size	L6 ±0.03	L7	T1	T2	T3 +0.1	T4 +0.1	T5	T6
70	20	5	–	7.5	3.1	–	–	–
80	40	–	9.7	9	–	2.1	8	6
120	40	–	12.8	10	–	2.1	–	–

Ordering data – Modular product system

Accessories

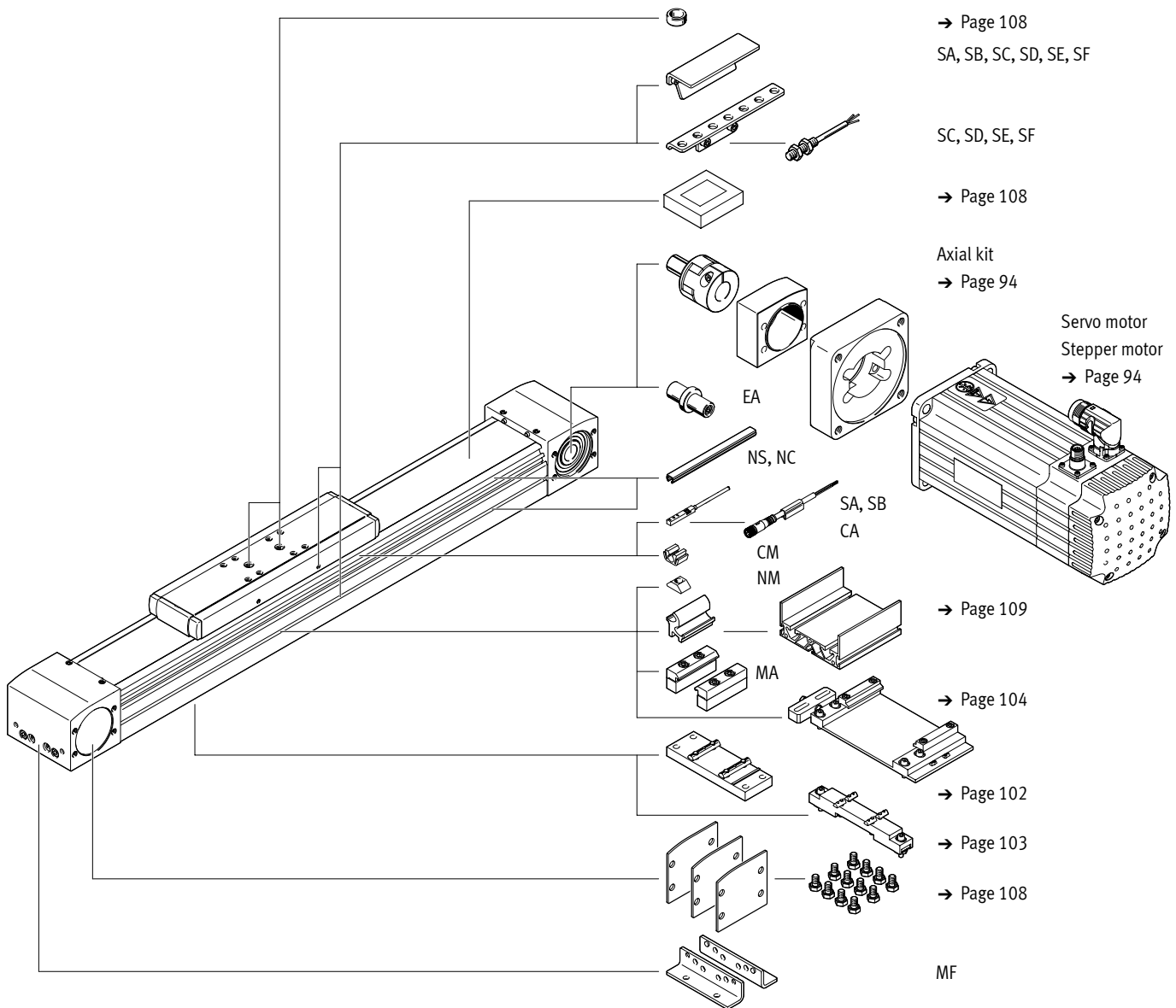

Ordering data – Modular product system

Ordering table		70	80	120	Conditions	Code	Enter code
Size		70	80	120			
Module no.		570502	570503	570504			
Design		Linear axis				ELGA	ELGA
Function		Toothed belt				-TB	-TB
Guide		Plain-bearing guide				-G	-G
Size	[mm]	70	80	120		-...	
Stroke length	[mm]	1 ... 8500				-...	
Stroke reserve	[mm]	0 ... 999 (0 = no stroke reserve)			[1]	-...H	
Protection against particles		Standard					
		Without cover strip				-PO	
Material of toothed belt		Chloroprene rubber					
		Coated PU				-PU2	
Accessories		Accessories enclosed separately				+	+
Foot mounting		1				MF	
Profile mounting		1 ... 50				...MA	
Proximity switch (SIES), inductive, slot type 8, PNP, incl. switch lug	N/O contact, 7.5 m cable	1 ... 6				...SA	
	N/C contact, 7.5 m cable	1 ... 6				...SB	
Proximity switch (SIEN), inductive, M8, PNP, incl. switch lug with sensor bracket	N/O contact, 2.5 m cable	1 ... 99				...SC	
	N/C contact, 2.5 m cable	1 ... 99				...SD	
	N/O contact, M8 plug	1 ... 99				...SE	
	N/C contact, M8 plug	1 ... 99				...SF	
Connecting cable 2.5 m, M8, 3-wire		1 ... 99				...CA	
Sensor slot cover		1 ... 50 (1 = 2 units, 500 mm)				...NS	
Mounting slot cover		1 ... 50 (1 = 2 units, 500 mm)				...NC	
Slot nut for mounting slot		1 ... 99				...NM	
Clip for sensor slot		10, 20, 30, 40, 50, 60, 70, 80, 90				...CM	
Drive shaft		1 ... 4				...EA	
Operating instructions		With operating instructions					
		Without operating instructions				-DN	

[1] ... H The sum of the nominal stroke and 2x stroke reserve must be at least 50 mm and must not exceed the maximum stroke length

The code SA, SB includes a switch lug in the scope of delivery.
The code SC, SD, SE, SF includes one switch lug and max. two sensor brackets in the scope of delivery.

Accessories

-  - Note

Depending on the combination of motor and drive, it may not be possible to reach the maximum feed force of the drive.

Permissible axis/motor combinations with axial kit

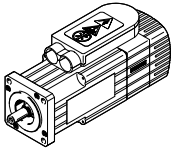
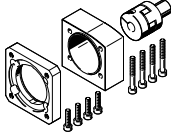
Motor/gear unit ¹⁾	Axial kit		Data sheets → Internet: eamm-a
			
Type	Part no.	Type	
ELGA-TB-...-70			
With servo motor			
EMMS-AS-70-...	1202331	EAMM-A-N38-70A	
With servo motor and gear unit			
EMMS-AS-55-... EMGA-60-P-G...-SAS-55	★ 1202253	EAMM-A-N38-60G	
EMMT-AS-60-... EMGA-60-P-G...-EAS-60	1456616	EAMM-A-N38-60H	
EMME-AS-60-... EMGA-60-P-G...-EAS-60	1456616	EAMM-A-N38-60H	
EMMS-AS-70-... EMGA-60-P-G...-SAS-70	★ 1202253	EAMM-A-N38-60G	
With servo motor and right-angle gear unit			
EMMT-AS-60-... EMGA-60-A-G...-60P	1456616	EAMM-A-N38-60H	
EMME-AS-60-... EMGA-60-A-G...-60P	1456616	EAMM-A-N38-60H	
With stepper motor			
EMMS-ST-87-...	★ 3324111	EAMM-A-N38-87A	
With stepper motor and gear unit			
EMMS-ST-57-... EMGA-60-P-G...-SST-57	★ 1202253	EAMM-A-N38-60G	
With integrated drive and gear unit			
EMCA-EC-67-... EMGC-60-...	1456616	EAMM-A-N38-60H	
EMMS-AS-70-...	1202331	EAMM-A-N38-70A	

1) The input torque must not exceed the max. permissible transferable torque of the axial kit.

Festo core product range



Generally ready for dispatch from the factory within 24 hours



Generally ready for dispatch from the factory within 5 days

Accessories

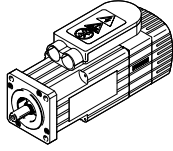
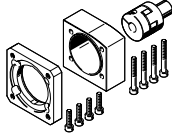
Permissible axis/motor combinations with axial kit		
Motor/gear unit ¹⁾	Axial kit	
		
Type	Part no.	Type
ELGA-TB-...-80		
With servo motor		
EMME-AS-100-...	1201894	EAMM-A-N48-100A
EMMS-AS-100-...	1201894	EAMM-A-N48-100A
With servo motor and gear unit		
EMMS-AS-55-... EMGA-60-P-G...-SAS-55	★ 1972527	EAMM-A-N48-60G
EMMT-AS-60-... EMGA-60-P-G...-EAS-60	1456618	EAMM-A-N48-60H
EMME-AS-60-... EMGA-60-P-G...-EAS-60	1456618	EAMM-A-N48-60H
EMMS-AS-70-... EMGA-60-P-G...-SAS-70	★ 1972527	EAMM-A-N48-60G
EMMS-AS-70-... EMGA-80-P-G...-SAS-70	★ 1258793	EAMM-A-N48-80G
EMME-AS-80-... EMGA-80-P-G...-EAS-80	★ 1258793	EAMM-A-N48-80G
EMME-AS-100-... EMGA-80-P-G...-SAS-100	★ 1258793	EAMM-A-N48-80G
EMMS-AS-100-... EMGA-80-P-G...-SAS-100	★ 1258793	EAMM-A-N48-80G
With servo motor and right-angle gear unit		
EMMT-AS-60-... EMGA-60-A-G...-60P	1456618	EAMM-A-N48-60H
EMME-AS-60-... EMGA-60-A-G...-60P	1456618	EAMM-A-N48-60H
EMME-AS-80-... EMGA-80-A-G...-80P	★ 1258793	EAMM-A-N48-80G
EMME-AS-100-... EMGA-80-A-G...-100A	★ 1258793	EAMM-A-N48-80G
With stepper motor and gear unit		
EMMS-ST-57-... EMGA-60-P-G...-SST-57	★ 1972527	EAMM-A-N48-60G
EMMS-ST-87-... EMGA-80-P-G...-SST-87	★ 1258793	EAMM-A-N48-80G
With integrated drive and gear unit		
EMCA-EC-67-... EMGC-60-...	1456618	EAMM-A-N48-60H

1) The input torque must not exceed the max. permissible transferable torque of the axial kit.

Festo core product range



Generally ready for dispatch from the factory within 24 hours
Generally ready for dispatch from the factory within 5 days

Accessories

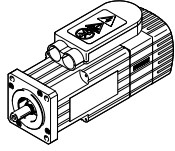
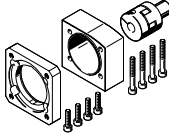
Permissible axis/motor combinations with axial kit		
Motor/gear unit ¹⁾	Axial kit	
		
Type	Part no.	Type
ELGA-TB-...-120		
With servo motor		
EMMS-AS-140-...	1201691	EAMM-A-N80-140A
With servo motor and gear unit		
EMMS-AS-70-... EMGA-80-P-G...-SAS-70	★ 2372096	EAMM-A-N80-80G
EMME-AS-80-... EMGA-80-P-G...-EAS-80	★ 2372096	EAMM-A-N80-80G
EMME-AS-100-... EMGA-80-P-G...-SAS-100	★ 2372096	EAMM-A-N80-80G
EMMS-AS-100-... EMGA-80-P-G...-SAS-100	★ 2372096	EAMM-A-N80-80G
EMME-AS-100-... EMGA-120-P-G...-SAS-100	★ 1201695	EAMM-A-N80-120G
EMMS-AS-100-... EMGA-120-P-G...-SAS-100	★ 1201695	EAMM-A-N80-120G
EMMS-AS-140-... EMGA-120-P-G...-SAS-140	★ 1201695	EAMM-A-N80-120G
With servo motor and right-angle gear unit		
EMME-AS-80-... EMGA-80-A-G...-80P	★ 2372096	EAMM-A-N80-80G
EMME-AS-100-... EMGA-80-A-G...-100A	★ 2372096	EAMM-A-N80-80G
With stepper motor and gear unit		
EMMS-ST-87-... EMGA-80-P-G...-SST-87	★ 2372096	EAMM-A-N80-80G

1) The input torque must not exceed the max. permissible transferable torque of the axial kit.

Festo core product range



Generally ready for dispatch from the factory within 24 hours

Generally ready for dispatch from the factory within 5 days

Accessories

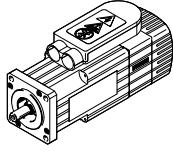
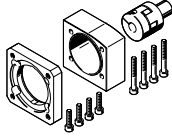
Permissible axis/motor combinations with axial kit		
Motor/gear unit ¹⁾	Axial kit	
		
Type	Part no.	Type
ELGA-TB-...-150		
With servo motor		
EMMS-AS-140-...	3657226	EAMM-A-L95-140A-G2
EMMS-AS-190-...	3659562	EAMM-A-L95-190A-G2
With servo motor and gear unit		
EMMS-AS-70-... EMGA-80-P-G...-SAS-70	3660191	EAMM-A-L95-80G-G2
EMME-AS-80-... EMGA-80-P-G...-EAS-80	3660191	EAMM-A-L95-80G-G2
EMME-AS-100-... EMGA-80-P-G...-SAS-100	3660191	EAMM-A-L95-80G-G2
EMMS-AS-100-... EMGA-80-P-G...-SAS-100	3660191	EAMM-A-L95-80G-G2
EMME-AS-100-... EMGA-120-P-G...-SAS-100	★ 3659941	EAMM-A-L95-120G-G2
EMMS-AS-100-... EMGA-120-P-G...-SAS-100	★ 3659941	EAMM-A-L95-120G-G2
EMMS-AS-140-... EMGA-120-P-G...-SAS-140	★ 3659941	EAMM-A-L95-120G-G2
With servo motor and right-angle gear unit		
EMME-AS-80-... EMGA-80-A-G...-80P	3660191	EAMM-A-L95-80G-G2
EMME-AS-100-... EMGA-80-A-G...-100A	3660191	EAMM-A-L95-80G-G2
With stepper motor and gear unit		
EMMS-ST-87-... EMGA-80-P-G...-SST-87	3660191	EAMM-A-L95-80G2

1) The input torque must not exceed the max. permissible transferable torque of the axial kit.



Festo core product range



Generally ready for dispatch from the factory within 24 hours

Generally ready for dispatch from the factory within 5 days

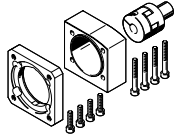
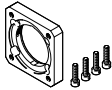
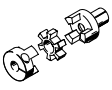
Accessories

Individual components of the axial kit				
Axial kit	Comprising: Motor flange	Coupling	Coupling housing	Screw set
				
Part no. Type	Part no. Type	Part no. Type	Part no. Type	Part no. Type
ELGA-TB-...-70				
★ 1202253 EAMM-A-N38-60G	1190015 EAMF-A-38D-60G/H	558001 EAMD-32-32-11-16X20	1345947 EAMK-A-N38-38D	1202262 EAHM-L5-M6-40
1456616 EAMM-A-N38-60H	1190015 EAMF-A-38D-60G/H	1377840 EAMD-32-32-14-16X20	1345947 EAMK-A-N38-38D	1202262 EAHM-L5-M6-40
1202331 EAMM-A-N38-70A	1202337 EAMF-A-38D-70A	558001 EAMD-32-32-11-16X20	1345947 EAMK-A-N38-38D	1202288 EAHM-L5-M6-35
★ 3324111 EAMM-A-N38-87A	3319868 EAMF-A-38D-87A	558001 EAMD-32-32-11-16X20	1345947 EAMK-A-N38-38D	1202288 EAHM-L5-M6-35
ELGA-TB-...-80				
★ 1972527 EAMM-A-N48-60G	1460111 EAMF-A-48C-60G/H	558001 EAMD-32-32-11-16X20	1345949 EAMK-A-N48-48C	4984529 EAHM-L5-M6-45
1456618 EAMM-A-N48-60H	1460111 EAMF-A-48C-60G/H	1377840 EAMD-32-32-14-16X20	1345949 EAMK-A-N48-48C	4984529 EAHM-L5-M6-45
★ 1258793 EAMM-A-N48-80G	1190375 EAMF-A-48C-80G	1781043 EAMD-42-40-20-16X25-U	1345949 EAMK-A-N48-48C	1201874 EAHM-L5-M6-50
1201894 EAMM-A-N48-100A	1201924 EAMF-A-48C-100A	558002 EAMD-42-40-19-16X25	1345949 EAMK-A-N48-48C	1201874 EAHM-L5-M6-50
ELGA-TB-...-120				
★ 2372096 EAMM-A-N80-80G	2372201 EAMF-A-80A-80G	558004 EAMD-56-46-20-23X27	1345953 EAMK-A-N80-80A	1201712 EAHM-L5-M8-60
★ 1201695 EAMM-A-N80-120G	1190702 EAMF-A-80A-120G	1188801 EAMD-56-46-25-23X27	1345953 EAMK-A-N80-80A	1201712 EAHM-L5-M8-60
1201691 EAMM-A-N80-140A	1190796 EAMF-A-80A-140A	558005 EAMD-56-46-24-23X27	1345953 EAMK-A-N80-80A	1201751 EAHM-L5-M8-75
ELGA-TB-...-150				
3660191 EAMM-A-L95-80G-G2	3305700 EAMF-A-95B-80G	3717812 EAMD-67-51-20-32X32-U	3712650 EAMK-A-L95-95A/B-G2	-
★ 3659941 EAMM-A-L95-120G-G2	3659724 EAMF-A-95A-120G-G2	558006 EAMD-67-51-25-32X32-U	3712650 EAMK-A-L95-95A/B-G2	567496 EAHM-L2-M8-70
3657226 EAMM-A-L95-140A-G2	558023 EAMF-A-95A-140A	558008 EAMD-67-51-24-32X32-U	3712650 EAMK-A-L95-95A/B-G2	567497 EAHM-L2-M8-80
3659562 EAMM-A-L95-190A-G2	1378473 EAMF-A-95A-190A	1379269 EAMD-67-51-32-32X32-U	3712650 EAMK-A-L95-95A/B-G2	567497 EAHM-L2-M8-80

 **Note**

For the optimum selection of axis/
motor combinations

→ Engineering software
PositioningDrives
www.festo.com

Accessories

Drive shaft EAMB

Alternative interface
 For ELGA-TB-KF/-KF-F1
 For ELGA-TB-RF/-RF-F1
 For ELGA-TB-G
 (order code EA)

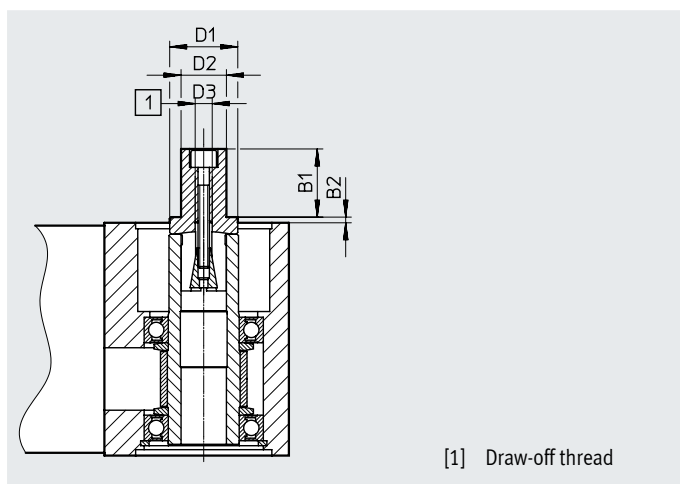

[1] Draw-off thread

Dimensions and ordering data

For size	B1	B2	D1 ∅	D2 ∅	D3	Weight [g]	Part no.	Type
70	21	1.85	24	15	M6	70	1344642	EAMB-24-9-15X21-16X20
80	21	2	24	15	M6	70	558036	EAMB-24-6-15X21-16X20
120	26	2	34	25	M10	201	558037	EAMB-34-6-25X26-23X27
150	30	3	44	35	M12	463	558038	EAMB-44-7-35X30-32X32

Accessories

Foot mounting HPE

For ELGA-TB-KF/-KF-F1

For ELGA-TB-RF/-RF-F1

For ELGA-TB-G

(order code MF)

Material:

Galvanised steel

RoHS-compliant

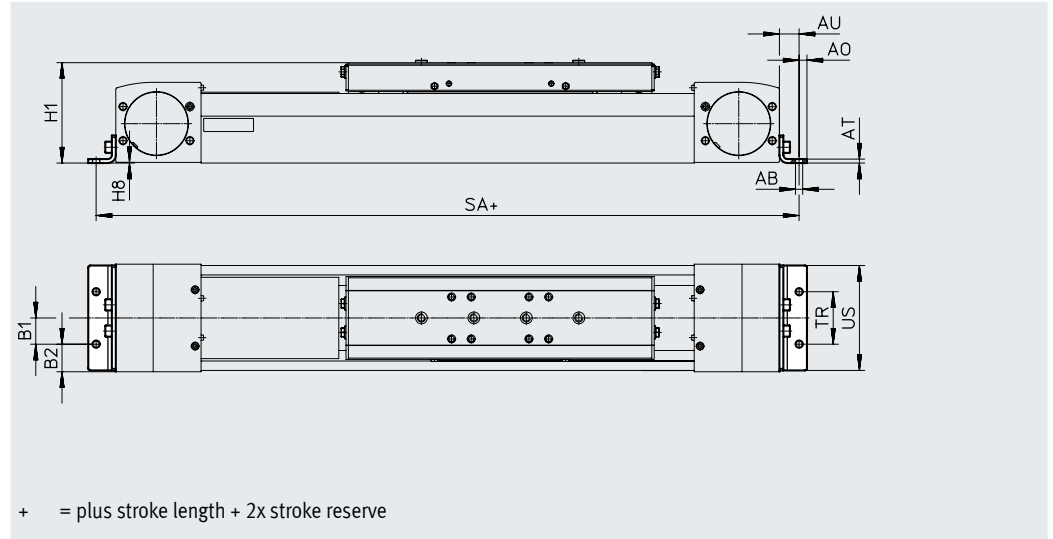

Dimensions and ordering data

For size	AB ∅	A0	AT	AU	B1	B2	H1	H8
70	5.5	6	3	13	20	14.5	64	0.5
80	5.5	6	3	13	20	21	76.5	0.5
120	9	8	6	22	40	20	111.5	0.5
150	9	12	8	25	40	35	141.5	1

For size	SA					TR	US
	ELGA-TB-KF	ELGA-TB-RF	ELGA-TB-RF-S	ELGA-TB-RF-L	ELGA-TB-G		
70	372	446	368	546	372	40	67
80	416	610	526	750	416	40	80
120	590	819	717	1049	590	80	116
150	762	–	–	–	–	80	150

For size	Weight [g]	Part no.	Type
70	115	558321	HPE-70
80	150	558322	HPE-80
120	578	558323	HPE-120
150	1181	3002636	HPE-150

Accessories

Profile mounting MUE

For ELGA-TB-KF

For ELGA-TB-RF

For ELGA-TB-G

(order code MA)

Material:

Anodised aluminium

RoHS-compliant

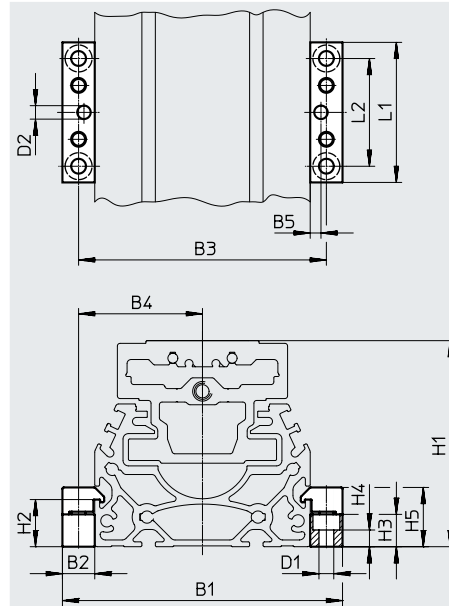

Dimensions and ordering data									
For size	B1	B2	B3	B4	B5	D1 ∅	D2 ∅ H7	H1	H2
70	91	12	79	39.5	4	5.5	5	64	17.5
80	104	12	92	46	4	5.5	5	76.5	17.5
120	154	19	135	67.5	4	9	5	111.5	16
150	188	19	169	84.5	4	9	5	141.5	16

For size	H3	H4	H5	L1	L2	Weight [g]	Part no.	Type
70	12	6.2	22	52	40	80	★ 558043	MUE-7 0/80
80	12	6.2	22	52	40	80	★ 558043	MUE-7 0/80
120	14	5.5	29.5	90	40	290	★ 558044	MUE-12 0/185
150	14	5.5	29.5	90	40	290	★ 558044	MUE-12 0/185

Festo core product range

- ★ Generally ready for dispatch from the factory within 24 hours
- ★ Generally ready for dispatch from the factory within 5 days

Accessories

Central support EAHF

For ELGA-TB-KF/-KF-F1

For ELGA-TB-RF/-RF-F1

For ELGA-TB-G

Material:

Anodised aluminium

RoHS-compliant

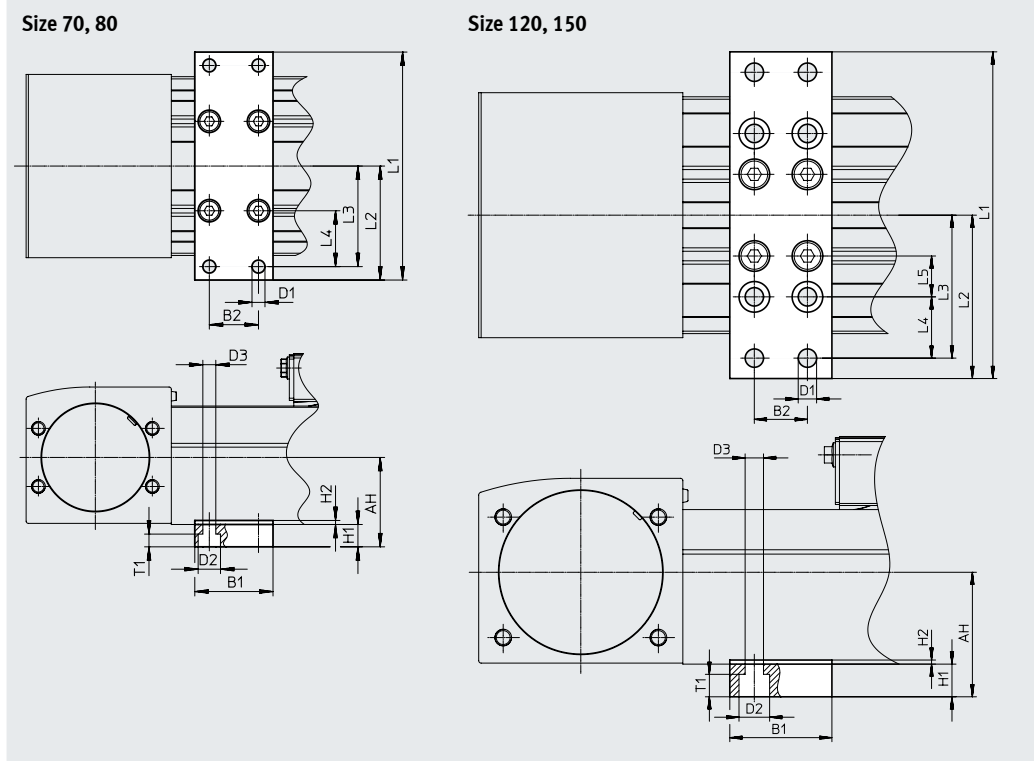

Dimensions and ordering data

For size	AH	B1	B2	D1 ∅	D2 ∅	D3 ∅	H1	L1
70	36.5	35	22	5.8	10	5.8	10	102
80	40							112
120	61	50	26	9	15	9	16	160
150	74.6							200

For size	L2	L3	L4	L5	T1	Weight [g]	Part no.	Type
70	51	45	25	-	5.7	113	2349256	EAHF-L5-70-P
80	56	50	30			123	3535188	EAHF-L5-80-P
120	80	70	30	20	11	384	2410274	EAHF-L5-120-P
150	100	90	50	-		495	3535189	EAHF-L5-150-P

Accessories

Adjusting kit EADC-E15

Material:
 EADC-E15-8 0/120: Wrought aluminium alloy
 EADC-E15-185: Steel
 RoHS-compliant

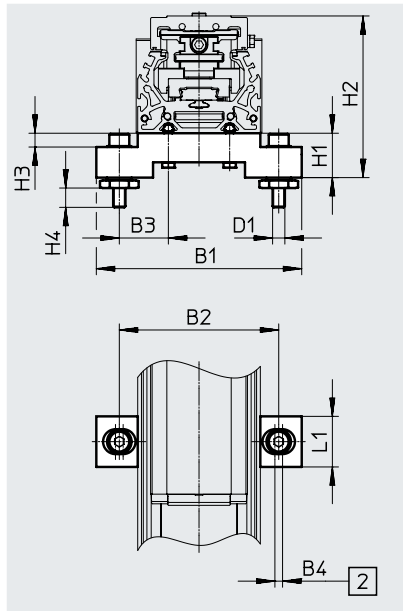
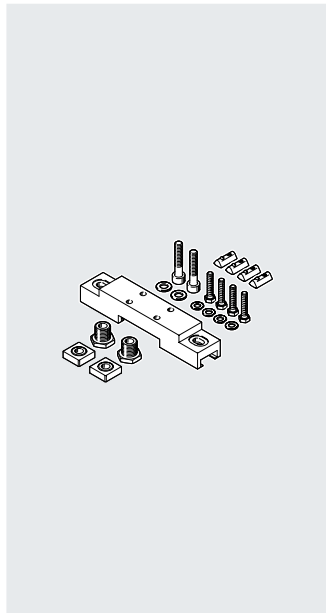

[2] Width of elongate hole

Dimensions and ordering data

For size	B1	B2	B3	B4	D1	H1
70	134	104	32	5	M8	29
80	134	104	32	5	M8	29
120	170	140	50	5	M8	29
150	236	209	64.5	5	M8	29

For size	H2	H3	H4	L1	Weight [g]	Part no.	Type
70	93	9	12.6	33	386	8047566	EADC-E15-80-E7
80	105.5	9	12.6	33	386	8047566	EADC-E15-80-E7
120	140.5	9	12.6	33	388	8047567	EADC-E15-120-E7
150	170.5	9	12.6	33	569	8047568	EADC-E15-185-E7

Accessories

Adjusting kit EADC-E16

Material:
Wrought aluminium alloy
RoHS-compliant

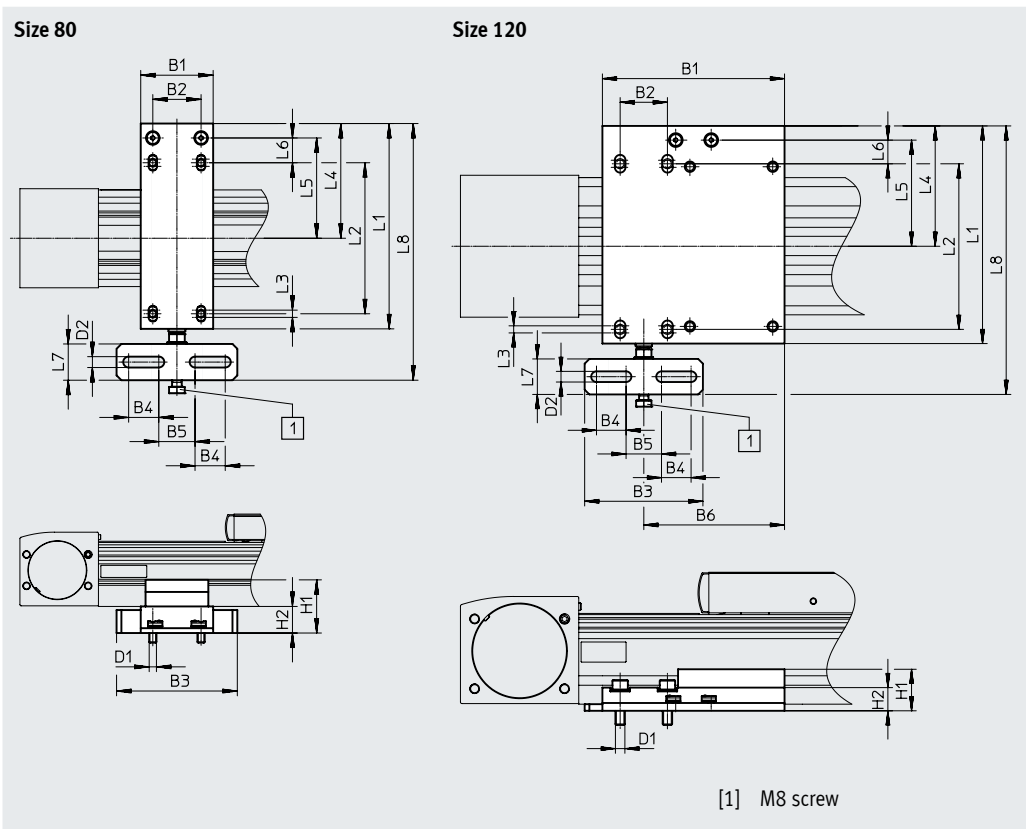
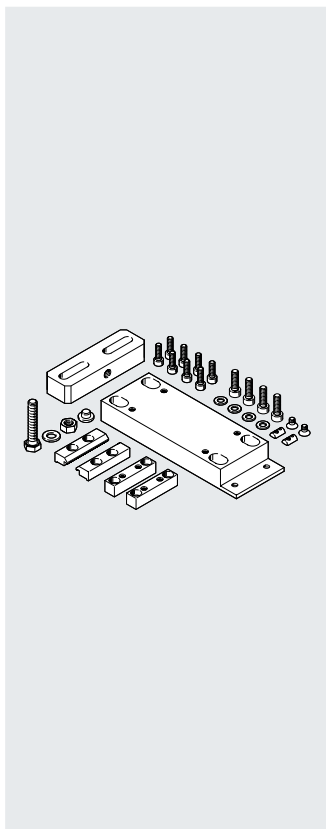

Dimensions and ordering data												
For size	B1	B2	B3	B4	B5	B6	D1	D2	H1	H2	L1	L2
80	60	40	100	25	30	-	M6	9	44	22	170	125
120	154	40	100	25	30	119	M8	9	35.1	19.6	184	140

For size	L3	L4	L5	L6	L7	L8	Weight [g]	Part no.	Type
80	6	95	83	20.5	30	212.5	828	8047577	EADC-E16-80-E7
120	6	101.7	89.7	20	30	227	1134	8047578	EADC-E16-120-E7

Accessories

Switch lug SF-EGC-1

for sensing via proximity switch
SIES-8M

For ELGA-TB-KF

For ELGA-TB-RF

For ELGA-TB-G

(order code SA or SB)

Material:

Galvanised steel

RoHS-compliant

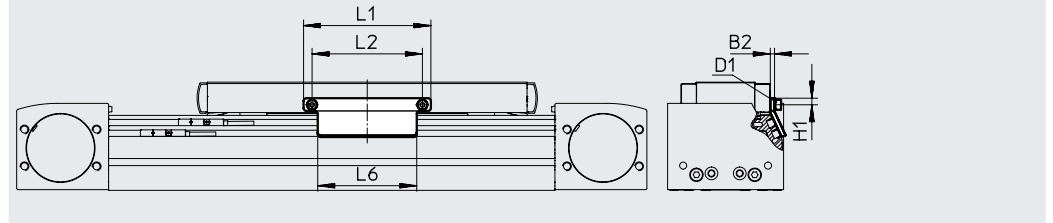
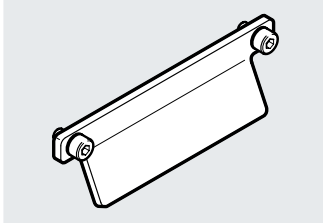

Dimensions and ordering data									
For size	B2	D1	H1	L1	L2	L6	Weight [g]	Part no.	Type
70	3	M4	4.65	70	56	50	50	★ 558047	SF-EGC-1-70
80	3	M4	4.65	90	78	70	63	★ 558048	SF-EGC-1-80
120	3	M5	8	170	140	170	147	★ 558049	SF-EGC-1-120
150	3	M5	10	230	200	230	246	★ 558051	SF-EGC-1-185

Festo core product range



Generally ready for dispatch from the factory within 24 hours

Generally ready for dispatch from the factory within 5 days

Accessories

Switch lug SF-EGC-2

For sensing with proximity switch
SIEN-M8B (order code SC, SD, SE or SF)
or SIES-8M
For ELGA-TB-KF
For ELGA-TB-RF
For ELGA-TB-G

Material:
Galvanised steel
RoHS-compliant

Sensor bracket HWS-EGC
For proximity switch SIEN-M8B
(order code SC, SD, SE or SF)

Material:
Galvanised steel
RoHS-compliant

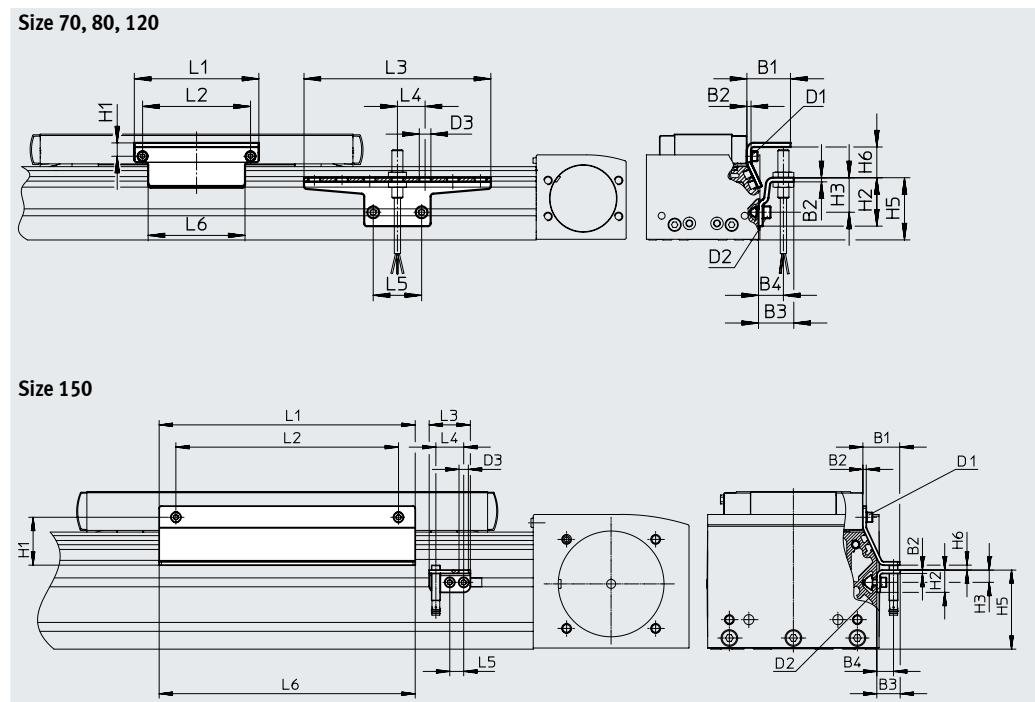
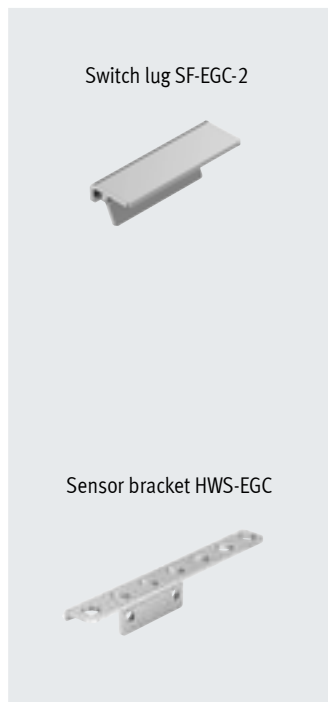

Dimensions and ordering data									
For size	B1	B2	B3	B4	D1	D2	D3	H1	H2
70	31.5	3	25.5	18	M4	M5	8.4	9.5	35
80	31.5	3	25.5	18	M4	M5	8.4	9.5	35
120	32	3	25.5	18	M5	M5	8.4	13.2	65
150	33	3	21	15	M5	M5	8.4	43	20

For size	H3	H5	H6 max.	L1	L2	L3	L4	L5	L6
70	25	45	13.5	70	56	135	20	35	50
80	25	45	23.5	90	78	135	20	35	70
120	55	75	24	170	140	215	20	35	170
150	11	71	4.5	230	200	37	25	12.5	230

For size	Weight [g]	Part no.	Type
Switch lug			
70	100	558052	SF-EGC-2-70
80	130	558053	SF-EGC-2-80
120	277	558054	SF-EGC-2-120
150	390	558056	SF-EGC-2-185

For size	Weight [g]	Part no.	Type
Sensor bracket			
70	110	558057	HWS-EGC-M5
80	110	558057	HWS-EGC-M5
120	217	570365	HWS-EGC-M8-B
150	58	560517	HWS-EGC-M8: KURZ

Note
The proximity switches SIEN-M8B cannot be mounted in the area of the profile mounting MUE.

Accessories

Switch lug EAPM

for sensing via proximity switch
SME-8M

For ELGA-TB-KF-F1

For ELGA-TB-RF-F1

Material:

Wrought aluminium alloy

RoHS-compliant

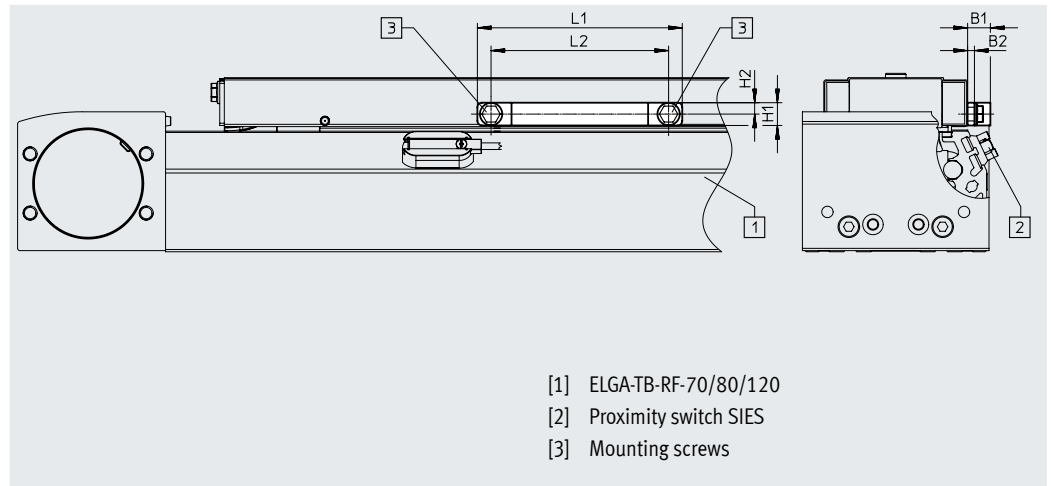

[1] ELGA-TB-RF-70/80/120

[2] Proximity switch SIES

[3] Mounting screws





Dimensions and ordering data

For size	B1	B2	H1	H2	L1	L2	Weight [g]	Part no.	Type
70	10	3	10	5	70	56	46	2417032	EAPM-L5-70-SLM
80	10	3	10	5	90	78	66	2671318	EAPM-L5-80-SLM
120	10	3	16	8	170	140	146	2671326	EAPM-L5-120-SLM

Ordering data

	For size	Description	Part no.	Type
	70 ... 120	<ul style="list-style-type: none"> For proximity switch SME-8M/SME-8 For ELGA-TB-KF-F1 For ELGA-TB-RF-F1 	525565	CRSMB-8-32

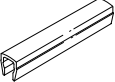
Accessories

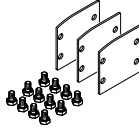
Ordering data						
	For size	Description	Order code	Part no.	Type	PE ¹⁾
Slot nut NST						
	70, 80	<ul style="list-style-type: none"> For mounting slot For ELGA-TB-KF/-KF-F1 For ELGA-TB-RF/-RF-F1 	NM	150914	NST-5-M5	1
			-	8047843	NST-5-M5-10	10
			-	8047878	NST-5-M5-50	50
	120, 150	<ul style="list-style-type: none"> For ELGA-TB-G 	NM	150915	NST-8-M6	1
			-	8047868	NST-8-M6-10	10
			-	8047869	NST-8-M6-50	50
Centring pin/sleeve ZBS/ZBH						
	For ELGA-TB-KF/-KF-F1					
	70	For slide	-	150928	ZBS-5	10
	70, 80, 120, 150			150927	ZBH-9	
	For ELGA-TB-RF/-RF-F1					
	70, 80, 120	For slide	-	150927	ZBH-9	10
	For ELGA-TB-G					
70	For slide	-	150928	ZBS-5	10	
80, 120			150927	ZBH-9		
Slot cover ABP						
	70, 80	<ul style="list-style-type: none"> For mounting slot Every 0.5 m For ELGA-TB-KF/-KF-F1 For ELGA-TB-RF/-RF-F1 For ELGA-TB-G 	NC	151681	ABP-5	2
	120, 150			151682	ABP-8	
Slot cover ABP-S						
	70 ... 150	<ul style="list-style-type: none"> For sensor slot Every 0.5 m For ELGA-TB-KF For ELGA-TB-RF For ELGA-TB-G 	NS	563360	ABP-5-S1	2
Clip SMBK						
	70 ... 150	<ul style="list-style-type: none"> For sensor slot, for attaching the proximity switch cables For ELGA-TB-KF For ELGA-TB-RF For ELGA-TB-G 	CM	534254	SMBK-8	10
Clamping component EADT						
	70, 80	Tool for retensioning the cover strip	-	8058451	EADT-S-L5-70	1
	120, 150			8058450	EADT-S-L5-120	
Cover kit EASC						
	70	For covering the sides of the drive cover	-	8049255	EASC-L5-70	3
	80			8049254	EASC-L5-80	
	120			8049253	EASC-L5-120	
	150			8049244	EASC-L5-150	

1) Packaging unit

Accessories

Mounting options between axis and support profile

Depending on the adapter kit, the spacing between the axis and the support profile is:
x = 20 mm or 50 mm

The support profile must be mounted using at least 2 adapter kits. For longer strokes, an adapter kit must be used every 500 mm.

Example

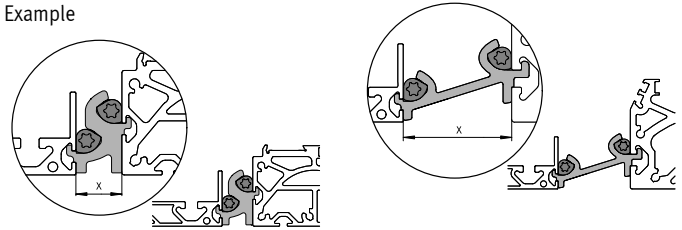

Ordering data					
	For size	Description	Part no.	Type	PE ¹⁾
Adapter kit DHAM					
	80	<ul style="list-style-type: none"> For mounting the support profile on the axis Spacing between axis and profile is 20 mm For ELGA-TB-KF For ELGA-TB-RF For ELGA-TB-G 	562241	DHAM-ME-N1-CL	1
	120, 150		562242	DHAM-ME-N2-CL	
	70, 80	<ul style="list-style-type: none"> For mounting the support profile on the axis Spacing between axis and profile is 50 mm For ELGA-TB-KF For ELGA-TB-RF For ELGA-TB-G 	574560	DHAM-ME-N1-50-CL	
	120, 150		574561	DHAM-ME-N2-50-CL	
Support profile HMIA					
	70 ... 150	<ul style="list-style-type: none"> For guiding an energy chain For ELGA-TB-KF For ELGA-TB-RF For ELGA-TB-G 	539379	HMIA-E07-	1

1) Packaging unit

Proximity switches for ELGA-TB-KF, ELGA-TB-RF, ELGA-TB-G

Ordering data – Proximity switches for T-slot, inductive

Data sheets → Internet: sies





	Type of mounting	Electrical connection	Switching output	Cable length [m]	Order code	Part no.	Type
N/O contact							
	Insertable in the slot from above, flush with the cylinder profile	Cable, 3-wire	PNP	7.5	SA	551386	SIES-8M-PS-24V-K-7,5-OE
		Plug M8x1, 3-pin		0.3	–	551387	SIES-8M-PS-24V-K-0,3-M8D
		Cable, 3-wire	NPN	7.5	–	551396	SIES-8M-NS-24V-K-7,5-OE
		Plug M8x1, 3-pin		0.3	–	551397	SIES-8M-NS-24V-K-0,3-M8D
N/C contact							
	Insertable in the slot from above, flush with the cylinder profile	Cable, 3-wire	PNP	7.5	SB	551391	SIES-8M-PO-24V-K-7,5-OE
		Plug M8x1, 3-pin		0.3	–	551392	SIES-8M-PO-24V-K-0,3-M8D
		Cable, 3-wire	NPN	7.5	–	551401	SIES-8M-NO-24V-K-7,5-OE
		Plug M8x1, 3-pin		0.3	–	551402	SIES-8M-NO-24V-K-0,3-M8D

Accessories

Proximity switches for ELGA-TB-KF, ELGA-TB-RF, ELGA-TB-G

Ordering data – Proximity switches M8 (round design), inductive



Data sheets → Internet: sien

	Electrical connection	LED	Switching output	Cable length [m]	Order code	Part no.	Type
N/O contact							
	Cable, 3-wire	■	PNP	2.5	SC	★ 150386	SIEN-M8B-PS-K-L
			NPN	2.5	–	★ 150384	SIEN-M8B-NS-K-L
	Plug M8x1, 3-pin	■	PNP	–	SE	★ 150387	SIEN-M8B-PS-S-L
			NPN	–	–	★ 150385	SIEN-M8B-NS-S-L
N/C contact							
	Cable, 3-wire	■	PNP	2.5	SD	150390	SIEN-M8B-PO-K-L
			NPN	2.5	–	150388	SIEN-M8B-NO-K-L
	Plug M8x1, 3-pin	■	PNP	–	ST	150391	SIEN-M8B-PO-S-L
			NPN	–	–	150389	SIEN-M8B-NO-S-L

Proximity switches for ELGA-TB-KF-F1, ELGA-TB-RF-F1

Ordering data – Proximity switches for T-slot, magnetic reed



Data sheets → Internet: sme

	Type of mounting	Switching output	Electrical connection	Cable length [m]	Part no.	Type
N/O contact						
	Insertable in the mounting kit from above	Contacting	Cable, 3-wire	2.5	★ 543862	SME-8M-DS-24V-K-2,5-OE
				5.0	★ 543863	SME-8M-DS-24V-K-5,0-OE
			Cable, 2-wire	2.5	★ 543872	SME-8M-ZS-24V-K-2,5-OE
				Plug M8x1, 3-pin	0.3	★ 543861
N/C contact						
	Insertable in the mounting kit lengthwise	Contacting	Cable, 3-wire	7.5	160251	SME-8-O-K-LED-24

Connecting cables for ELGA-TB-...

Ordering data – Connecting cables

Data sheets → Internet: nebu

	Electrical connection, left	Electrical connection, right	Cable length [m]	Part no.	Type
	Straight socket, M8x1, 3-pin	Cable, open end, 3-wire	2.5	159420	SIM-M8-3GD-2,5-PU
			2.5	★ 541333	NEBU-M8G3-K-2.5-LE3
			5	★ 541334	NEBU-M8G3-K-5-LE3
	Angled socket, M8x1, 3-pin	Cable, open end, 3-wire	2.5	★ 541338	NEBU-M8W3-K-2.5-LE3
			5	★ 541341	NEBU-M8W3-K-5-LE3

Ordering data – Encoder cables for displacement encoder, ELGA-...-M1/-M2

Data sheets → Internet: nebm

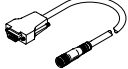
	Electrical connection, left	Electrical connection, right	Cable length [m]	Part no.	Type
	Displacement encoder ELGA-...-M1/-M2	Motor controller CMMP-AS	5	1599105	NEBM-M12G8-E-5-S1G9-V3
			10	1599106	NEBM-M12G8-E-10-S1G9-V3
			15	1599107	NEBM-M12G8-E-15-S1G9-V3
			χ ¹⁾	1599108	NEBM-M12G8-E-...-S1G9-V3

1) Max. cable length 25 m.