

# Product data sheet

Specifications



interface plug in relay, Harmony Electromechanical Relays, 10A, 1CO, basic, with LED, without lockable test button, 230V AC

RXG16P7

## Main

Range of product	Harmony Electromechanical Relays
Series name	RXG series
Product or component type	Plug-in relay
Relay type	Interface relay
Contacts type and composition	1 C/O
[Uc] control circuit voltage	230 V AC
[Ithe] conventional enclosed thermal current	10 A at -40...55 °C

## Complementary

status LED	With
Electrical durability	100000 cycles for NO at 55 °C 100000 cycles for NC at 55 °C
[Ui] rated insulation voltage	250 V conforming to IEC 300 V conforming to CSA 300 V conforming to UL
Removable legend	Without
Maximum switching voltage	250 V AC 30 V DC
Drop-out voltage threshold	$\geq 0.3 U_c$ AC
[Ie] rated operational current	10 A at 30 V (DC) conforming to UL 10 A at 30 V (DC) conforming to IEC 10 A at 250 V (AC) conforming to UL 10 A at 250 V (AC) conforming to IEC
Load current	10 A at 250 V AC
Minimum switching capacity	500 mW at 100 mA, 5 V DC
Maximum switching capacity	2500 VA
Control type	Without lockable test button
Average resistance	23500 Ohm at 23 °C +/- 15 %
Contact resistance	100 mOhm
Insulation resistance	1000 MOhm at 500 V DC
Electrical insulation class	Class F
Mechanical durability	10000000 cycles
Safety reliability data	B10d = 100000
Operating rate	$\leq 1800$ cycles/hour under load $\leq 18000$ cycles/hour no-load

<b>Utilisation coefficient</b>	20 %
<b>Operating time</b>	20 ms
<b>Reset time</b>	20 ms
<b>Dielectric strength</b>	1000 V AC between contacts with micro disconnection 5000 V AC between coil and contact with reinforced insulation 1300 V AC between terminals and case with basic insulation
<b>[Uimp] rated impulse withstand voltage</b>	1200 V AC between contacts with micro disconnection 6000 V between coil and contact with reinforced insulation 1500 V between terminals and case with basic insulation
<b>Overvoltage category</b>	III
<b>Protection category</b>	RT I
<b>Pollution degree</b>	2
<b>Test levels</b>	Level A group mounting
<b>Device presentation</b>	Complete product
<b>Contacts material</b>	Silver alloy (AgSnO2In2O3)
<b>Shape of pin</b>	Flat (faston type)
<b>Product weight</b>	0.019 kg

## Environment

<b>Standards</b>	CSA C22.2 No 14 UL 508 IEC 61810-1
<b>Product certifications</b>	CSA CE UL EAC
<b>Ambient air temperature for storage</b>	-40...85 °C
<b>Ambient air temperature for operation</b>	-40...70 °C
<b>IP degree of protection</b>	IP40
<b>Relative humidity</b>	10...85 %
<b>Vibration resistance</b>	3 gn, amplitude = +/- 0.75 mm (f = 10...150 Hz)in operation 5 gn, amplitude = +/- 0.75 mm (f = 10...150 Hz)not in operation

## Packing Units

<b>Unit Type of Package 1</b>	PCE
<b>Number of Units in Package 1</b>	1
<b>Package 1 Height</b>	1.400 cm
<b>Package 1 Width</b>	3.200 cm
<b>Package 1 Length</b>	3.600 cm
<b>Package 1 Weight</b>	18.000 g
<b>Unit Type of Package 2</b>	BB1
<b>Number of Units in Package 2</b>	10
<b>Package 2 Height</b>	3.500 cm
<b>Package 2 Width</b>	8.400 cm
<b>Package 2 Length</b>	9.200 cm
<b>Package 2 Weight</b>	206.000 g

---

<b>Unit Type of Package 3</b>	S01
<b>Number of Units in Package 3</b>	200
<b>Package 3 Height</b>	15.000 cm
<b>Package 3 Width</b>	15.000 cm
<b>Package 3 Length</b>	40.000 cm
<b>Package 3 Weight</b>	4.477 kg

---

## **Contractual warranty**

---

<b>Warranty (in months)</b>	60
-----------------------------	----



## Environmental Data

Schneider Electric aims to achieve Net Zero status by 2050 through supply chain partnerships, lower impact materials, and circularity via our ongoing “Use Better, Use Longer, Use Again” campaign to extend product lifetimes and recyclability.

[Environmental Data explained >](#)

[How we assess product sustainability >](#)



### Environmental footprint

Total lifecycle Carbon footprint	14 kg CO2 eq.
Carbon footprint of the manufacturing phase [A1 to A3]	0.2 kg CO2 eq.
Carbon footprint of the distribution phase [A4]	0.1 kg CO2 eq.
Carbon footprint of the installation phase [A5]	0 kg CO2 eq.
Carbon footprint of the use phase [B2, B3, B4, B6]	14 kg CO2 eq.
Carbon footprint of the end-of-life phase [C1 to C4]	0.1 kg CO2 eq.
Environmental Disclosure	<a href="#">Product Environmental Profile</a>

### Use Better



### Materials and Substances

Packaging made with recycled cardboard	No
Packaging without single use plastic	No
EU RoHS Directive	<a href="#">Compliant</a>
REACH Regulation	<a href="#">Free of Substances of Very High Concern above the threshold</a>

### Use Longer



### Lifetime extension

Repair	No
--------	----

### Use Again



### Repack and remanufacture

Recyclability potential, in %	70
End of life manual availability	<a href="#">End of Life Information</a>
Take-back	No

Dimensions Drawings

Dimensions

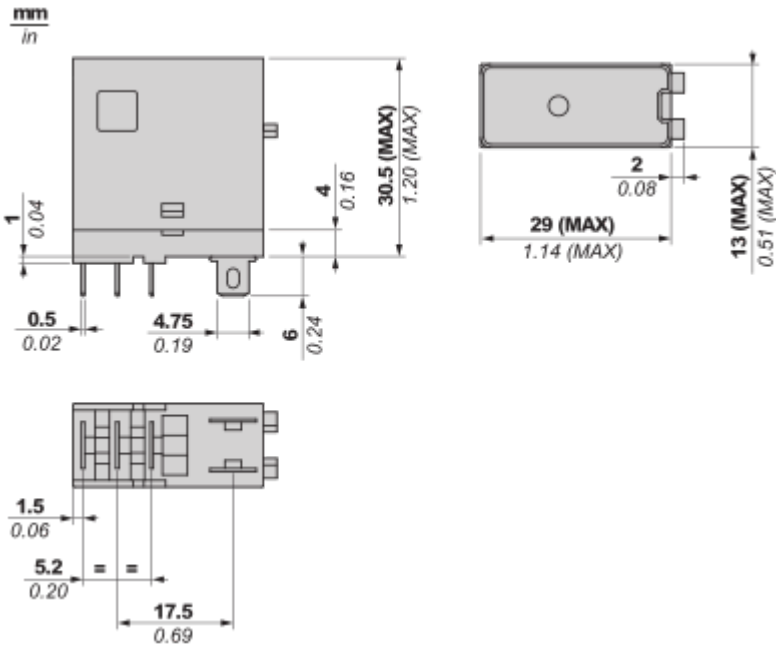

Connections and Schema

Wiring Diagram

---

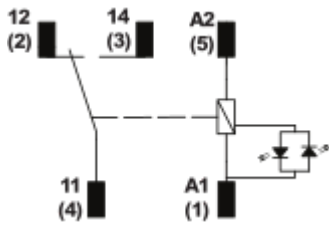

Performance Curves

Performance Curves

---

Maximum Switching Capacity

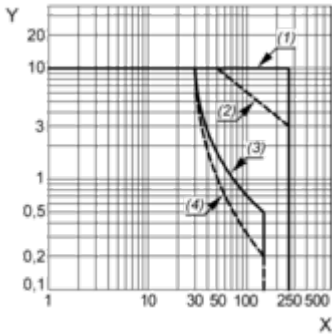

X : Switching voltage (V)

Y : Switching current (A)

(1) AC Resistive Load

(2) AC Inductive Load  $\cos(\phi)=0.4$

(3) DC Resistive Load

(4) DC Inductive Load (L/R=7ms)

Life Expectancy

Resistive Load

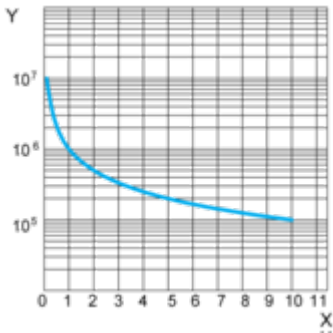

X : Contact Current (A)

Y : Operating Cycle Number

Life Expectancy

Inductive Load

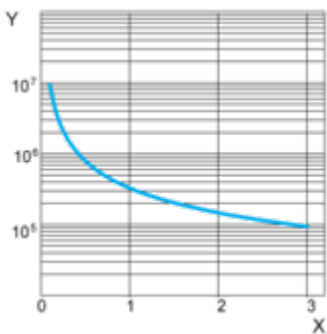

X : Contact Current (A)

Y : Operating Cycle Number

**NOTE:** These are typical curves, actual durability depends on load, environment, duty cycle, etc.

Coil Operating Range

---

AC Coil Operating Range VS Ambient Temperature

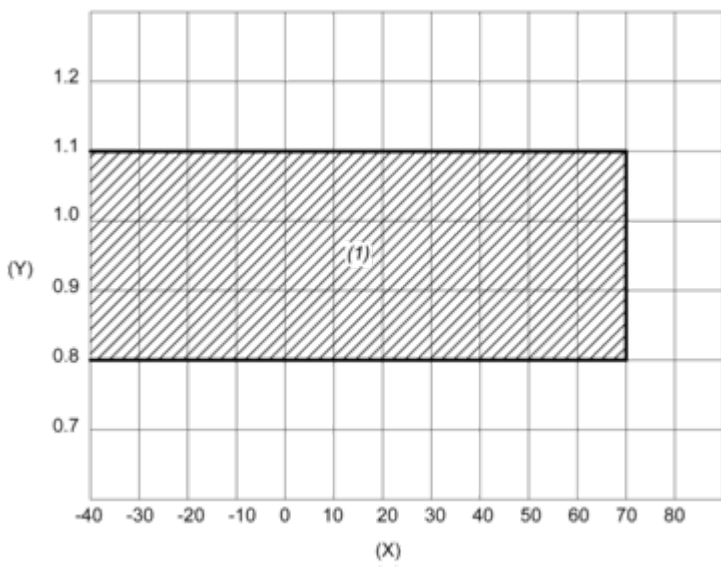

X : Ambient temperature (°C)

Y : Coil voltage (U/Uc)

(1) Permitted operating range area

Technical Illustration

Dimensions

---

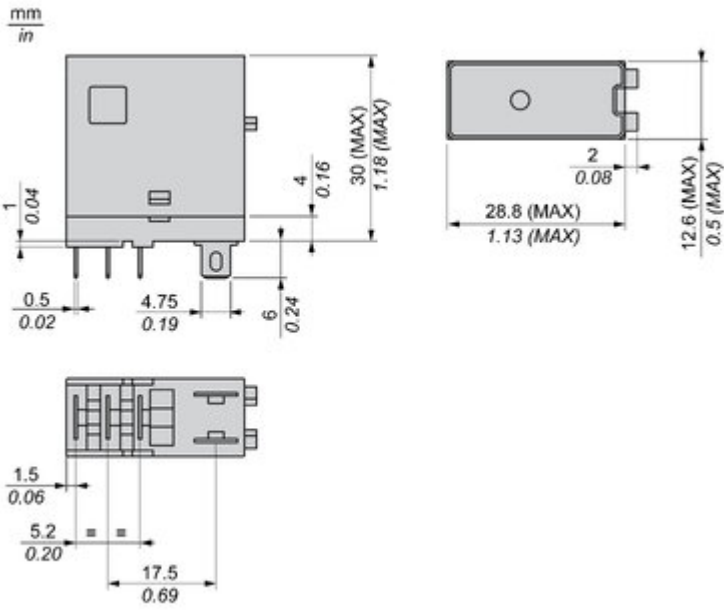

Image of product / Alternate images

Alternative

---

