

Product data sheet

Specifications



safety controller XPS-MC - 24 V DC - 32 input - 46 LEDs signalling

XPSMC32ZPACK

⚠ Discontinued on: 30 Nov 2023

⚠ Discontinued

Main

| | |
|-----------------------------|---|
| Range of product | Preventa Safety automation |
| Product or component type | Kit configurable safety controller |
| Safety module name | XPSMC |
| Safety use category | Category 4 maximum conforming to EN 954-1/EN/ISO 13849-1 PLE maximum conforming to EN/ISO 13849-1 SIL 3 maximum conforming to IEC 61508 |
| Type of start | Configurable |
| Standards | EN 954-1/EN/ISO 13849-1 EN/IEC 60947-5-1 EN/IEC 60204-1 EN/IEC 61496-1 IEC 61508 EN 574/ISO 13851 EN 1760-1/ISO 13856-1 |
| Product certifications | UL CSA TÜV |
| [Us] rated supply voltage | 24 V DC - 20...20 % |
| Number of inputs | 32 |
| Communication port protocol | Modbus with 1 RJ45 port(s), serial link, transmission rate: 1200 bps, 2400 bps, 4800 bps, 9600 bps or 19200 bps |
| Safety level | Can reach PL e/category 4 conforming to EN 954-1/EN/ISO 13849-1 Can reach SIL 3 conforming to IEC 61508 |

Complementary

| | |
|-----------------|--|
| Kit composition | Safety controller Ethernet cable 2m Configuration software Connection cable Set of cage clamp terminals USB/RS485 converter Set of screw terminals Packaging small model for software configuration VDE slot screwdriver 2.5 x 75 mm Printed packaging label 80 x 50 mm |
|-----------------|--|

| | |
|--|--|
| Function of module | Dynamic monitoring of hydraulic valves on linear presses Eccentric press Emergency stop monitoring, with or without time delay, 1 or 2-channel wiring Enabling switch monitoring, 2 or 3 contacts Foot switch monitoring Guard monitoring for injection presses and blowing machines Guard monitoring with 1 or 2 limit switches Hydraulic press Magnetic switch monitoring Monitoring safety stop at top dead centre on eccentric press Muting function of light curtains Position selector Safety mat monitoring Safety time delays Shaft/chain breaking monitor Zero speed detection Light curtain monitoring category 4 conforming to EN/IEC 61496 Two-hand control category 3 conforming to EN 574/ISO 13851 |
| Synchronisation time between inputs | Depending on configuration selected |
| Power consumption in W | 12 W |
| Input protection type | External fuse 16 A |
| [Uc] control circuit voltage | 28.8 V |
| Maximum line resistance | 100 Ohm <2000 m |
| Output type | 2 relays, 2 NO contacts (4 NO total) circuit(s) Solid state, 6 circuit(s), volt-free |
| Breaking capacity | 180 VA holding AC-15 C300 relay output 1800 VA inrush AC-15 C300 relay output |
| Breaking capacity | 2 A at 24 V for static output circuit 1.5 A at 24 V (DC-13) time constant: 50 ms for relay output |
| Output thermal current | 4 A for both outputs simultaneously 6 A for 1 output and 2 A for the other for relay output |
| [Ith] conventional free air thermal current | 16 A for relay output 6.5 A for static output circuit |
| Associated fuse rating | 16 A gL for power supply 4 A gL for relay output 6 A fast blow for relay output |
| Minimum output current | 10 mA for relay output |
| Minimum output voltage | 17 V for relay output |
| Response time | Configurable : 20 ms or 30 ms with software XPSMCWIN |
| [Ui] rated insulation voltage | 300 V (pollution degree 2) conforming to IEC 60647-5-1, DIN VDE 0110 part 1 |
| [Uimp] rated impulse withstand voltage | 4 kV overvoltage category III conforming to IEC 60647-5-1, DIN VDE 0110 part 1 |
| Method of access | Slave |
| Exchange size | 14 words |
| Number of addresses | 1...247 for Modbus |
| Parity | Even for Modbus No for Modbus Odd for Modbus |
| Data format | 1 start bit/8 data bits 1 stop bit even or odd 2 stop bits without parity RTU (Remote Terminal Unit) mode |
| Supported modbus function | 01: 8-bit output data/32-bit input data 02: 32-bit input data/8-bit output data 03: information and errors |
| Local signalling | 46 LEDs |

| | |
|-------------------------|----------------|
| Mounting support | Mounting plate |
| Depth | 153 mm |
| Height | 151.5 mm |
| Width | 74 mm |
| Product weight | 0.84 kg |

Environment

| | |
|--|---------------------------------|
| IP degree of protection | IP20 conforming to EN/IEC 60529 |
| Ambient air temperature for operation | -10...55 °C |
| Ambient air temperature for storage | -25...85 °C |

Packing Units

| | |
|-------------------------------------|---------|
| Unit Type of Package 1 | PCE |
| Number of Units in Package 1 | 1 |
| Package 1 Height | 24.5 cm |
| Package 1 Width | 24.5 cm |
| Package 1 Length | 27.5 cm |
| Package 1 Weight | 2.15 kg |

Contractual warranty

| | |
|-----------------------------|----|
| Warranty (in months) | 18 |
|-----------------------------|----|



Environmental Data

Schneider Electric aims to achieve Net Zero status by 2050 through supply chain partnerships, lower impact materials, and circularity via our ongoing “Use Better, Use Longer, Use Again” campaign to extend product lifetimes and recyclability.

[Environmental Data explained >](#)

[How we assess product sustainability >](#)



Environmental footprint

| | |
|--|----------------|
| Total lifecycle Carbon footprint | 538 kg CO2 eq. |
| Carbon footprint of the manufacturing phase [A1 to A3] | 74 kg CO2 eq. |
| Carbon footprint of the distribution phase [A4] | 0.3 kg CO2 eq. |
| Carbon footprint of the installation phase [A5] | 0 kg CO2 eq. |
| Carbon footprint of the use phase [B2, B3, B4, B6] | 446 kg CO2 eq. |
| Carbon footprint of the end-of-life phase [C1 to C4] | 4 kg CO2 eq. |

Use Better



Materials and Substances

| | |
|-------------------|--|
| EU RoHS Directive | Compliant By Exemption |
| PVC free | Yes |

Use Longer



Lifetime extension

| | |
|--------|----|
| Repair | No |
|--------|----|

Use Again



Repack and remanufacture

| | |
|---------------------------------|---|
| Recyclability potential, in % | 34 |
| End of life manual availability | End of Life Information |
| WEEE Label |  The product must be disposed on European Union markets following specific waste collection and never end up in rubbish bins |

Dimensions Drawings

Dimensions

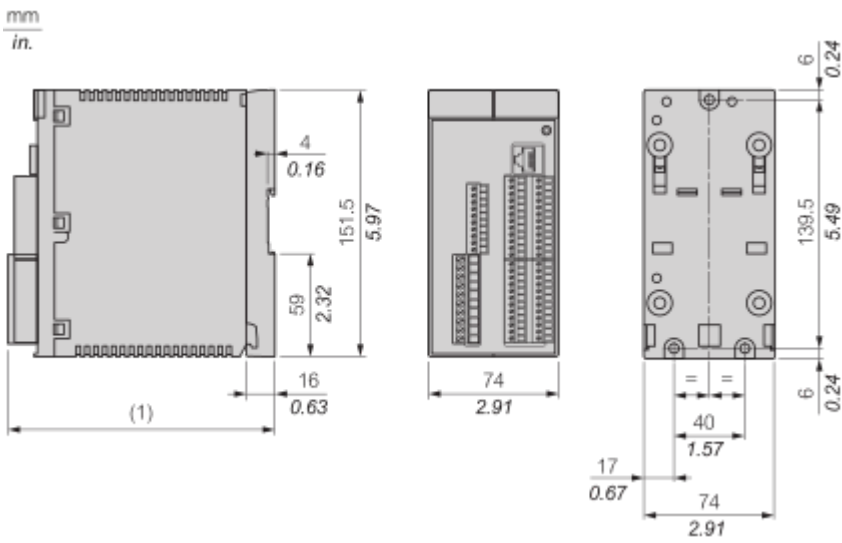

(1)
When using XPSMCTS• connectors, this dimension is 153 mm (6.02 in)
When using XPSMCTC• connectors, this dimension is 151.5 mm (5.96 in)

Mounting and Clearance

Installation

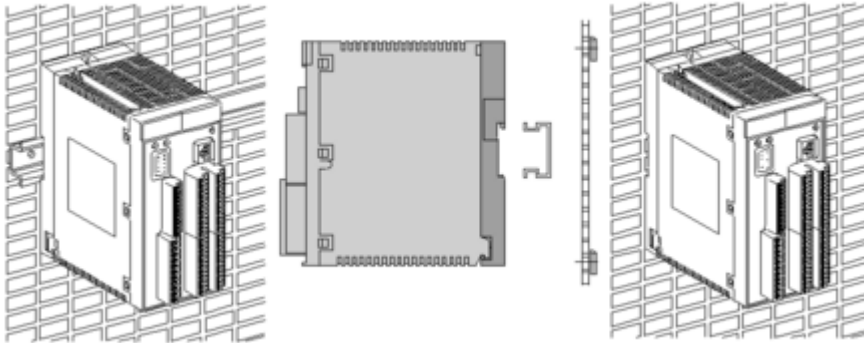

Metal adaptor for fixing on metal: DIN rail 35 mm/1.38 in.

Connections and Schema

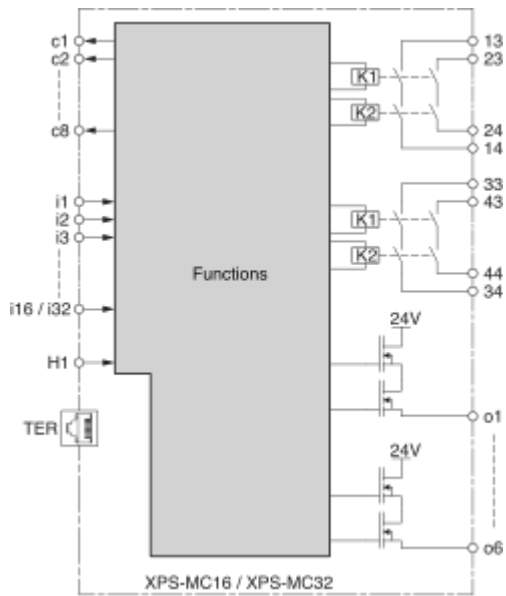

Function Diagram





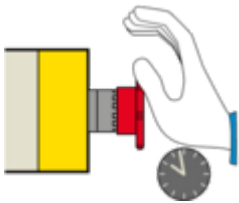
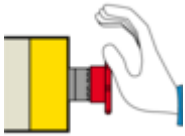
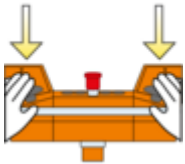
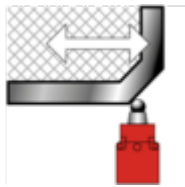

Note: Refer to the instruction sheet available in the documents section for a detailed connection diagram.

Technical Description

Safety Functions

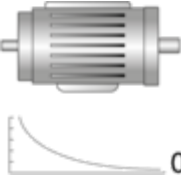
| | |
|---|--|
|  | <ul style="list-style-type: none"> • Emergency stop monitoring with time delay: <ul style="list-style-type: none"> ◦ 1 channel wiring, with automatic start. ◦ 2 channel wiring, with start button. |
|  | <ul style="list-style-type: none"> • Emergency stop monitoring without time delay: <ul style="list-style-type: none"> ◦ 1 channel wiring, with automatic start. ◦ 2 channel wiring, with start button. |
|  | <ul style="list-style-type: none"> • Two-hand control. |
|  | <ul style="list-style-type: none"> • Guard monitoring: <ul style="list-style-type: none"> ◦ with 1 limit switch. ◦ with 2 limit switches. ◦ with 2 limit switches, with guard locking. |
|  | <ul style="list-style-type: none"> • Magnetic switch monitoring. |

| | |
|---|---|
|  | <ul style="list-style-type: none"> • Sensing mat monitoring. |
|  | <ul style="list-style-type: none"> • Light curtains monitoring: <ul style="list-style-type: none"> ◦ Relay output type. ◦ Solid-state output type. • “Muting” function for light curtains. |
|  | <ul style="list-style-type: none"> • Zero speed detection. |
|  | <ul style="list-style-type: none"> • Safety time delays. |
|  | <ul style="list-style-type: none"> • Enabling switching monitoring: <ul style="list-style-type: none"> ◦ 2 contact type. ◦ 3 contact type. |

Other functions:

- Foot switch monitoring
- Position selector