



DOP-B03 High Color • Wide Screen • User-Friendly HMI Products

B03S210 Instruction Sheet

(1) Preface

Thank you for purchasing DELTA's DOP-B series. This instruction sheet will be helpful in the installation, wiring and inspection of Delta HMI. Before using the product, please read this instruction sheet to ensure correct use. You should thoroughly understand all safety precautions before proceeding with the installation, wiring and operation. Place this instruction sheet in a safe location for future reference. Please observe the following precautions:

- Install the product in a clean and dry location free from corrosive and inflammable gases or liquids.
- Ensure that all wiring instructions and recommendations are followed.
- Ensure that HMI is correctly connected to a ground. The grounding method must comply with the electrical standard of the country (Please refer to NFPA 70: National Electrical Code, 2005 Ed.).
- Do not disassemble HMI, modify or remove wiring when power is applied to HMI.
- Do not touch the power supply during operation. Otherwise, it may cause electric shock.

If you have any questions during operation, please contact our local distributors or Delta sales representatives.

The content of this instruction sheet may be revised without prior notice. Please consult our distributors or download the most updated version at <http://www.delta.com.tw/ia>.

(2) Safety Precautions

Carefully note and observe the following safety precautions when receiving, inspecting, installing, operating, maintaining and troubleshooting. The following words, DANGER, WARNING and STOP are used to mark safety precautions when using the Delta's HMI product. Failure to observe these precautions may void the warranty!

Installation

- Comply with quick start for installation. Otherwise it may cause equipment damage.
- Do not install the product in a location that is outside the stated specification for the HMI. Failure to observe this caution may result in electric shock, fire, or explosion.
- Do not install the product in a location where temperatures will exceed specification for the HMI. Failure to observe this caution may result in abnormal operation or damage the product.
- Please note that this equipment has obtained EMC registration for commercial use. In the event that it has been mistakenly sold or purchased, please exchange it for equipment certified for home use.
- Do not use this product as an alarm device for disaster early warning that may result in personal injury, equipment damage, or system emergency stop.



Wiring

- Connect the ground terminals to a class-3 ground (Ground resistance should not exceed 100Ω). Improper grounding may result in communication error, electric shock or fire.



Operation

- The users should use Delta Screen Editor Software to perform editing in Delta's HMI product. To perform editing and confirming HMI programs without using Delta Screen Editor software in Delta's HMI product may result in abnormal operation.
- To prevent the personal injury and equipment damage, when designing HMI programs, please ensure that a communication error occurred between Delta's HMI product and the connecting controller or equipment will not result in system failure or malfunction.
- Please be sure to backup the screen data and HMI programs in case they are lost, accidentally deleted or worse.
- Do not modify wiring during operation. Otherwise it may result in electric shock or personal injury.
- Never use a hard or pointed object to hit or strike the screen as doing this may damage the screen and let the screen has not respond at all, and then cause HMI to work abnormally.



Maintenance and Inspection

- Do not touch any internal or exposed parts of the HMI as electrical shock may result.
- Do not remove operation panel while power is on. Otherwise electrical shock may result.
- Wait at least 10 minutes after power has been removed before touching any HMI terminals or performing any wiring and/or inspection as an electrical charge may still remain in the HMI with hazardous voltages even after power has been removed.
- Turn the power off before changing backup battery and check system settings after finishing change. (all data will be cleared after changing battery).
- Be sure the ventilation holes are not obstructed during operation. Otherwise malfunction may result due to bad ventilation or overheating troubles.



Wiring Method



- Do not use a voltage that will exceed specification for the HMI. Failure to observe this caution may result in electric shock or fire.
- Remove the terminal block from the HMI before wiring.
- Insert only one wire into one terminal on the terminal block.
- If the wiring is in error, perform the wiring again with proper tools. Never use force to remove the terminals or wires. Otherwise, it may result in malfunction or damage.
- For the power line that forced to take out, ensure to check wiring again and restart.

Communication Wiring



- Comply with communication wiring specification for wiring.
- Wiring length should comply with the stated specification for the HMI.
- Proper grounding to avoid bad communication quality.
- To avoid noise and interference, the communication cable, all power cables, and motor power cable should be placed in separate conduits.

(3) Pin Definition of Serial Communication

DOP-B03S210 COM1 Port

COM Port	PIN	MODE1	MODE2	MODE3
		RS-232	RS-485	RS-422
	1		D+	TXD+
	2	RXD		
	3	TXD		
	4			RXD+
	5	GND	GND	GND
	6		D-	TXD-
	7	RTS		
	8	CTS		
	9			RXD-

Note1: Blank = No Connection.

(4) Parts Names

DOP-B03S210 (Front View)

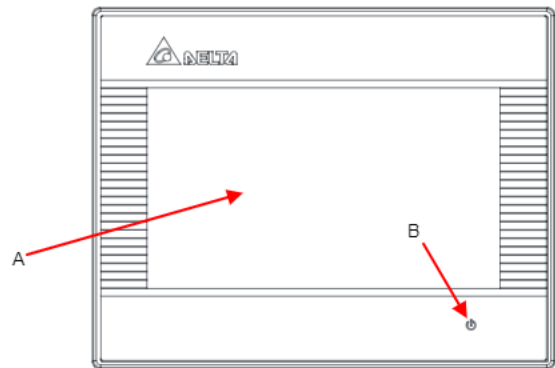

A	Touch Screen / Display	
B	Power LED Indicator (Ⓛ)	Note: Ⓛ Lights in green when HMI works normally.

DOP-B03S210 (Rear View)

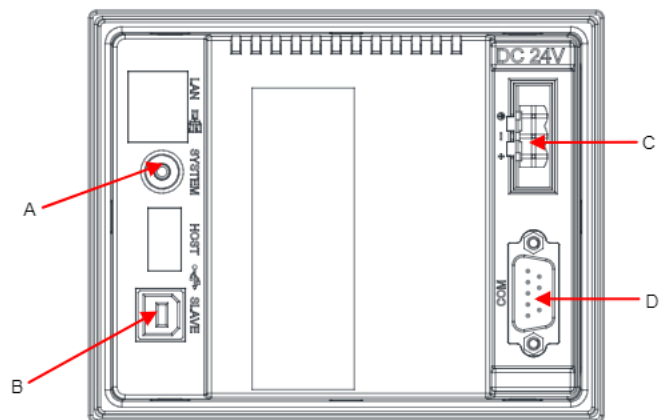

A	System Key	B	USB Slave
C	Power Input Terminal	D	COM1

(5) Dimensions

DOP-B03S210

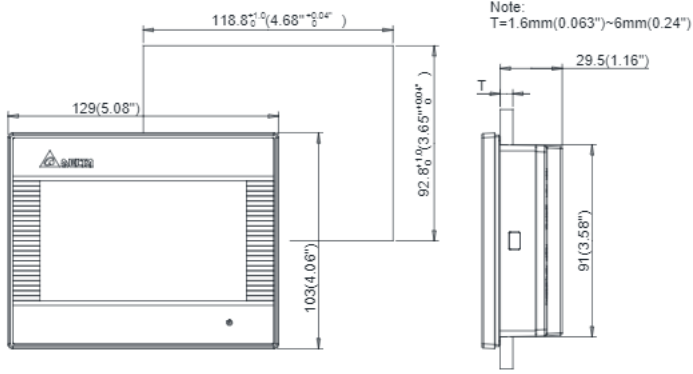

- 1) The half-life of backlight is defined as original luminance being reduced by 50% when the maximum driving current is supplied to HMI. The life of LED backlight shown here is an estimated value under 25°C normal temperature and humidity conditions.
- 2) The value of the power consumption indicates the electrical power consumed by HMI only without connecting to any peripheral devices. In order to ensure the normal operation, it is recommended to use a power supply which the capacity is 1.5 ~ 2 times the value of the power consumption.
- 3) Some models are in the process of application to certification. For more information, please consult our distributors.
- 4) The content of this instruction sheet may be revised without prior notice. Please consult our distributors or download the most updated version at <http://www.delta.com.tw/ia/>.

(6) Specifications

MODEL		DOP-B03S210
LCD MODULE	Display Type	4.3" TFT LCD (65536 colors)
	Resolution	480 x 272 pixels
	Backlight	LED Back Light (less than 20,000 hours half-life at 25°C) ^(Note 1)
	Display Size	95.04 x 53.856mm
Operation System		Delta Real Time OS
MCU		32-bit RISC Micro-controller
NOR Flash ROM		Flash ROM 8 MB (OS System: 2MB / User Application: 6MB)
SDRAM		64Mbytes
Backup Memory		N/A
Buzzer		Multi-Tone Frequency (2K ~ 4K Hz) / 85dB
USB		1 USB Slave Ver 2.0
Serial COM Port	COM1	RS-232(supports hardware flow control) / RS-422 / RS-485
Cooling Method		Natural air circulation
Safety Approval		CE / UL ^(Note 3)
Waterproof Degree		IP65 / NEMA4 ^(Note 3)
Operation Voltage ^(Note 2)		DC +24V (-10% ~ +15%) (please use isolated power supply)
Voltage Endurance		AC500V for 1 minute (between charging (DC24V terminal) and FG terminals)
Power Consumption ^(Note 2)		1.7W
Backup Battery		N/A
Backup Battery Life		N/A
Operation Temperature		0oC ~ 50oC
Storage Temperature		-20oC ~ +60oC
Ambient Humidity		10% ~ 90% RH [0 ~ 40°C], 10% ~ 55% RH [41 ~ 50°C], Pollution Degree 2
Vibration		IEC 61131-2 compliant 5Hz≤f < 8.3Hz = Continuous: 3.5mm, 8.3Hz≤f≤150Hz = Continuous: 1.0g
Shock		IEC 60068-2-27 compliant 15g peak for 11 ms duration, X, Y, Z directions for 6 times
Dimensions (W) x (H) x (D) mm		129 x 103 x 39
Panel Cutout (W) x (H) mm		118.8 x 92.8
Weight		Approx. 230g



DOP-B03 高彩·宽屏幕·友好人机界面

B03S210 安装说明

(1) 一般注意事项

感谢您使用本产品，本人机界面安装说明书提供 DOP-B 系列人机界面的相关资讯。在使用之前，请您仔细阅读本说明书以确保使用上的正确。此外，请妥善将其放置在明显的地点以便随时查阅。下列事项在您尚未读完本说明书前，请务必遵守：

- 安装的环境必须没有水气，腐蚀性气体及可燃性气体。
- 接线时，请依接线图说明施工。
- 接地工程必须确实实施，接地时须遵照国家现行相关电工法规的规定施行（请参考 NFPA 70: National Electrical Code, 2005 Ed.）。
- 在通电时，请勿拆解人机界面或更改配线。
- 在通电运作时，请勿接触电源处，以免触电。

如果您在使用上仍有问题，请咨询经销商或者本公司客服中心。由于产品精益求精，当内容规格有所修正时，请咨询代理商或至台达网站

(<http://www.delta.com.tw/ia/>) 下载最新版本。

(2) 安全注意事项

安装、配线、操作、维护及检查时，应随时注意以下安全注意事项。

安装注意

- 依照手册指定的方式安装人机界面，否则可能导致设备损坏。
- 禁止将本产品暴露在有水气、腐蚀性气体、可燃性气体等物质的场所下使用，否则可能会造成触电、火灾或爆炸。
- 请勿将人机界面安装在超过规格范围的温度环境中，否则可能造成人机界面无法正常运作或损坏。
- 本产品为 KCC Class A (商用设备) 产品且通过试验认证，其设计的目的是在商业或是工业环境使用，而非家庭环境中使用。若在此情况下不小心购买或售出人机界面产品，请将其更换为有符合 KCC Class B (家用设备) 认证的产品。
- 请勿将人机界面用于可能会造成人员伤亡、设备损坏或系统停机等警报机台。

配线注意

- 请将接地端子连接到 class-3 (100Ω 以下) 接地，接地不良可能会造成通讯异常、触电或火灾。

操作注意

- 人机界面需配合编辑软件规划画面，未经规划或确认的人机界面可能会导致不正常运转结果。为避免操作人身伤害或设备损坏，规划人机画面时，要确保人机界面及其连接控制器或设备之间的通讯故障不会造成设备功能无法正常运作。
- 为避免意外遗失程序，请务必备份规划好的人机界面画面程序。
- 不得在开启电源情况下改变配线，否则可能造成触电或人员受伤。
- 请勿以尖锐物品碰触面板，否则可能导致面板凹陷，进而无法使人机界面正常运作。

保养及检查

- 禁止接触人机界面内部，否则可能会造成触电。
- 电源启动时，禁止拆下人机界面面板，否则可能会造成触电。

- 电源关闭 10 分钟内，不得接触接线端子，残余电压可能造成触电。
- 更换备用电池时，应切断电源再进行，并在更换后重新检查系统设定值。
- 人机界面在操作时，排气孔不可封住，否则人机容易因为散热不良而造成故障。

配线方法

- 请勿使用超过人机界面规格范围的电压，否则可能会引起触电或火灾。
- 配线时请将快速接头从人机界面的本体上拆下来。
- 快速接头的一个电线插入口，请仅插入一根电线。
- 对于错误强行拔出电线的动作，请重新检查连接电线再启动。



通讯电路的配线

- 请依标准规格采用通讯配线线材。
- 通讯线材长度需在符合规定内。
- 采用正确的接地回路，以避免通讯不良。
- 为防止较大的噪声干扰引起人机界面无法正常运作，请用单独的配线槽将人机界面的通讯电缆和所有电源线及电机动力线分开。



(3) 通讯脚位定义

DOP-B03S210 COM 定义

COM Port 示意图	脚位	MODE1	MODE2	MODE3
		RS-232	RS-485	RS-422
	1		D+	TXD+
	2	RXD		
	3	TXD		
	4			RXD+
	5	GND	GND	GND
	6		D-	TXD-
	7	RTS		
	8	CTS		
	9			RXD-

注 1：空白 = 不需连接

(4) 各部位说明

DOP-B03S210 (正面)

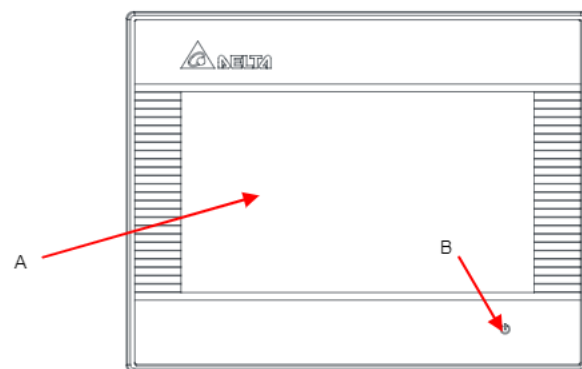

A	操作 / 显示区域	B	电源指示灯
---	-----------	---	-------

DOP-B03S210 (背面)

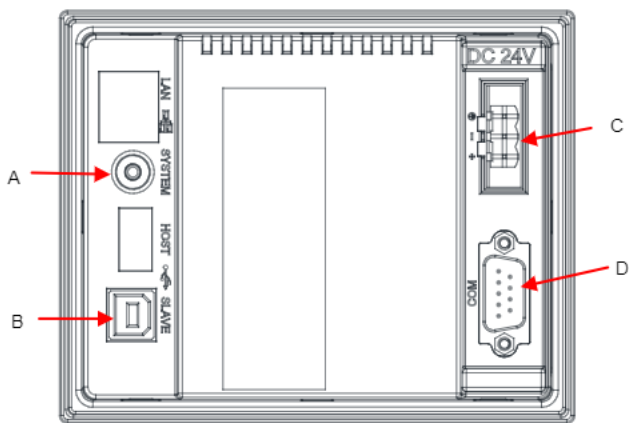

A	系统键	B	USB Slave
C	电源输入端子	D	COM 1

(5) 开孔尺寸

DOP-B03S210

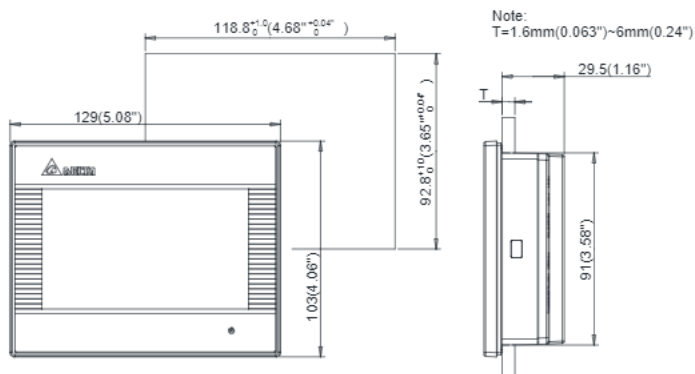

(6) 硬件规格

型号		DOP-B03S210
显示器	面板种类	4.3" TFT LCD (65535 色)
	分辨率	480 x 272 pixels
	背光灯	LED Back Light (常温 25°C 下半衰期>2 万小时) (Note 1)
	显示范围	95.04 x 53.856mm
作业系统		Delta Real Time OS
中央处理器		32-bit RISC Micro-controller
存储器 ROM		Flash ROM 8 MB (OS System: 2MB / User Application: 6MB)
内部存储器		64Mbytes
断电保持存储器		N/A
蜂鸣器		Multi-Tone Frequency (2K ~ 4K Hz) / 85dB
USB		1 USB Slave Ver 2.0
串行通讯口	COM1	RS-232(支持流量控制) / RS-422 / RS-485
冷却方式		自然冷却
安规认证		CE / UL (Note 3)
面板防水等级		IP65 / NEMA4 (Note 3)
工作电压 (Note2)		DC +24V (-10% ~ +15%) (请使用屏蔽式电源供应器)
绝缘耐力		DC24V 端子与 FG 端子间 : AC500V, 1 分钟

型号	DOP-B03S210
消耗功率 (Note 2)	1.7W
存储器备份电池	N/A
备份电池寿命	N/A
操作温度	0°C ~ 50°C
储存温度	-20°C ~ +60°C
工作环境	10% ~ 90% RH【0 ~ 40°C】 , 10% ~ 55% RH【41 ~ 50°C】 , 污染等级 2
耐震动	IEC61131-2 规定连续震动 5Hz~8.3Hz 3.5mm, 8.3Hz~150Hz 1G
耐冲击	IEC60068-2-27 规定耐冲击 11ms, 15G Peak, X, Y, Z 方向 各 6 次
尺寸 (W)x(H)x(D) mm	129 x103 x 39
开孔尺寸 (W) x (H) mm	118.8 x 92.8
重量	约 230g

NOTE

- 1) 背光模组半衰期的定义：最大驱动电流下，背光亮度衰退到最大亮度的一半时，即为半衰期。所标示的寿命时间为 25°C 常温常湿工作环境下的预估值。
- 2) 消耗功率为无外接周边设备时，人机本体所消耗的功率。建议选用的电源供应器容量为标示消耗功率的 1.5~2 倍，以确保人机工作正常。
- 3) 部份机种认证申请中，详细认证机种请咨询各区域代理商。
- 4) 本人机界面安装手册内所记载的规格若有变更，本公司恕不另行通知。当内容规格有所修正时，请咨询代理商或至台达网站 <http://www.delta.com.tw/ia/>。

