

# Product datasheet

Specifications

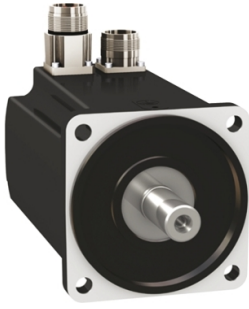

servo motor BMH, Lexium 32,  
3.3Nm, 6000rpm, untapped shaft,  
with brake, IP65, IP67, 128bit  
encoder, straight

BMH1001P21F1A

! Discontinued

! Discontinued on: 30 Jun 2023

## Main

Device short name	BMH
Product or component type	Servo motor
Maximum mechanical speed	6000 rpm
Continuous stall torque	3.3 N.m for LXM32.D12N4 at 3 A, 400 V, three phase 3.3 N.m for LXM32.D12N4 at 3 A, 480 V, three phase 3.4 N.m for LXM32.D18N4 at 6 A, 400 V, three phase 3.4 N.m for LXM32.D18N4 at 6 A, 480 V, three phase
Peak stall torque	10.8 N.m for LXM32.D12N4 at 3 A, 400 V, three phase 10.8 N.m for LXM32.D12N4 at 3 A, 480 V, three phase 10.8 N.m for LXM32.D18N4 at 6 A, 400 V, three phase 10.8 N.m for LXM32.D18N4 at 6 A, 480 V, three phase
Nominal output power	800 W for LXM32.D12N4 at 3 A, 400 V, three phase 800 W for LXM32.D12N4 at 3 A, 480 V, three phase 1300 W for LXM32.D18N4 at 6 A, 400 V, three phase 1300 W for LXM32.D18N4 at 6 A, 480 V, three phase
Nominal torque	1.9 N.m for LXM32.D12N4 at 3 A, 400 V, three phase 1.9 N.m for LXM32.D12N4 at 3 A, 480 V, three phase 3.1 N.m for LXM32.D18N4 at 6 A, 400 V, three phase 3.1 N.m for LXM32.D18N4 at 6 A, 480 V, three phase
Nominal speed	4000 rpm for LXM32.D12N4 at 3 A, 400 V, three phase 4000 rpm for LXM32.D12N4 at 3 A, 480 V, three phase 4000 rpm for LXM32.D18N4 at 6 A, 400 V, three phase 4000 rpm for LXM32.D18N4 at 6 A, 480 V, three phase
Product compatibility	LXM32.D12N4 at 400...480 V three phase LXM32.D18N4 at 400...480 V three phase
Shaft end	Smooth shaft
IP degree of protection	IP65 standard IP67 with IP67 kit
Speed feedback resolution	131072 points/turn
Holding brake	With
Mounting support	International standard flange
Electrical connection	Straight connectors

## Complementary

Range compatibility	Lexium 32
[Us] rated supply voltage	480 V
Network number of phases	Three phase
Continuous stall current	3.15 A

Continuous power	1.76 W
Maximum current Irms	11.9 A for LXM32.D12N4 11.9 A for LXM32.D18N4
Maximum permanent current	11.93 A
Second shaft	Without second shaft end
Shaft diameter	19 mm
Shaft length	40 mm
Feedback type	Single turn SinCos Hiperface
Holding torque	5.5 N.m holding brake
Motor flange size	100 mm
Number of motor stacks	1
Torque constant	1.1 N.m/A at 120 °C
Back emf constant	70.3 V/krpm at 120 °C
Number of motor poles	10
Rotor inertia	3.68 kg.cm <sup>2</sup>
Stator resistance	3.1 Ohm at 20 °C
Stator inductance	13.9 mH at 20 °C
Stator electrical time constant	4.5 ms at 20 °C
Maximum radial force Fr	900 N at 1000 rpm 720 N at 2000 rpm 630 N at 3000 rpm 570 N at 4000 rpm 530 N at 5000 rpm
Maximum axial force Fa	0.2 x Fr
Brake pull-in power	12 W
Type of cooling	Natural convection
Length	170.3 mm
Centring collar diameter	95 mm
Centring collar depth	3.5 mm
Number of mounting holes	4
Mounting holes diameter	9 mm
Circle diameter of the mounting holes	115 mm
Net weight	4.8 kg
Sizing reference	BMH1001P
Network number of phases	3
Accuracy error [angular]	1.4 °
Temperature copper hot	135 °C
Temperature magnet hot	100 °C
Temperature magnet rt	20 °C

## Packing Units

Unit Type of Package 1	PCE
Number of Units in Package 1	1

Package 1 Height	22.0 cm
Package 1 Width	20.0 cm
Package 1 Length	40.0 cm
Package 1 Weight	5.1 kg
Unit Type of Package 2	P06
Number of Units in Package 2	24
Package 2 Height	105.0 cm
Package 2 Width	80.000 cm
Package 2 Length	60.000 cm
Package 2 Weight	36.1 kg

## Contractual warranty

Warranty (in months)	18
----------------------	----



## Environmental Data

Schneider Electric aims to achieve Net Zero status by 2050 through supply chain partnerships, lower impact materials, and circularity via our ongoing “Use Better, Use Longer, Use Again” campaign to extend product lifetimes and recyclability.

[Environmental Data explained >](#)

[How we assess product sustainability >](#)

### Use Better



#### Materials and Substances

EU RoHS Directive

[Compliant By Exemption](#)

PVC free

Yes

### Use Longer



#### Lifetime extension

Repair

No

### Use Again



#### Repack and remanufacture

End of life manual availability

No need of specific recycling operations

WEEE Label



The product must be disposed on European Union markets following specific waste collection and never end up in rubbish bins

Dimensions Drawings

Servo Motors Dimensions

Example with Straight Connectors

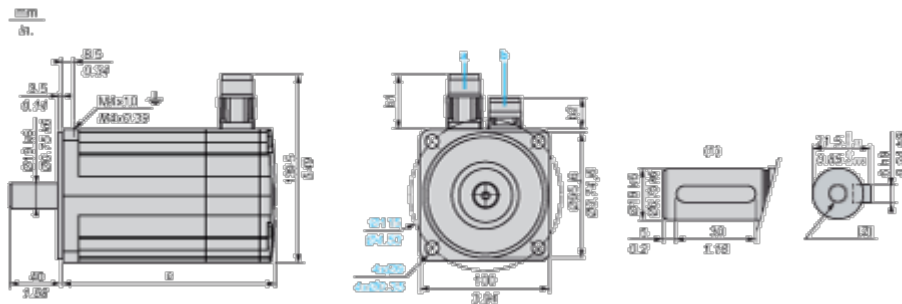

- a: Power supply for servo motor brake
- b: Power supply for servo motor encoder
- (1) Shaft end, keyed slot (optional)
- (2) For screw M6 x 21 mm/M6 x 0.83 in.

Dimensions in mm

Straight connectors		Rotatable angled connectors		c (without brake)	c (with brake)
b1	b2	b1	b2		
39.5	25.5	39.5	39.5	128	170

Dimensions in in.

Straight connectors		Rotatable angled connectors		c (without brake)	c (with brake)
b1	b2	b1	b2		
1.55	1.00	1.55	1.55	5.03	6.69

Performance Curves

400 V 3-Phase Supply Voltage

---

Torque/Speed Curves

Servo motor with LXM32•D12N4 servo drive

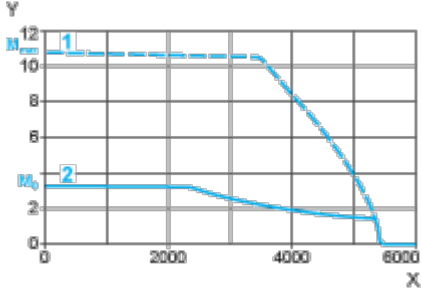

X Speed in rpm

Y Torque in Nm

1 Peak torque

2 Continuous torque

Servo motor with LXM32•D18N4 servo drive

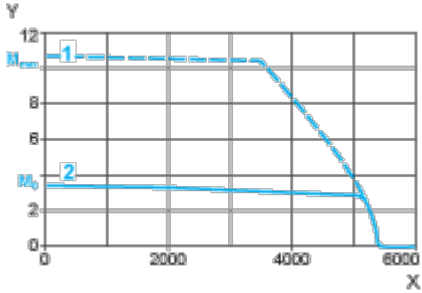

X Speed in rpm

Y Torque in Nm

1 Peak torque

2 Continuous torque

480 V 3-Phase Supply Voltage

---

Torque/Speed Curves

Servo motor with LXM32•D12N4 servo drive

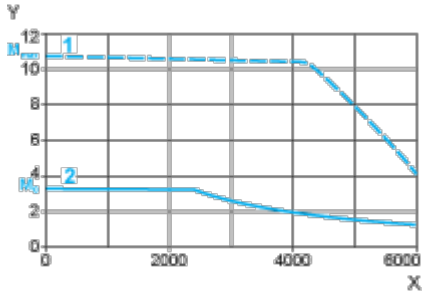

- X Speed in rpm
- Y Torque in Nm
- 1 Peak torque
- 2 Continuous torque

Servo motor with LXM32•D18N4 servo drive

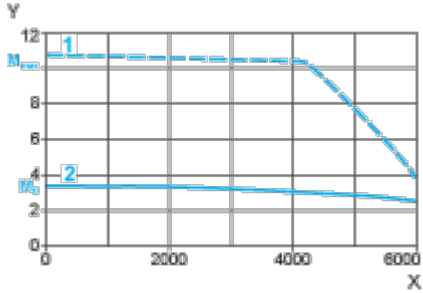

- X Speed in rpm
- Y Torque in Nm
- 1 Peak torque
- 2 Continuous torque