

# Product datasheet

Specifications



## non-isolated analog input module X80 - 8 inputs - for severe environments

BMXAMI0800H

### Main

Range of product	Modicon X80
Product or component type	Analog input module
Product specific application	For severe environments
Electrical connection	28 ways 1 connector
Isolation between channels	Non isolated
Input level	High level
Analogue input number	8
Analogue input type	Current +/- 20 mA Current 0...20 mA Current 4...20 mA Voltage +/- 10 V Voltage +/- 5 V Voltage 0...10 V Voltage 0...5 V Voltage 1...5 V

### Complementary

Analog/digital conversion	16 bits
Analogue input resolution	15 bits + sign
Permitted overload on inputs	+/- 30 mA 0...20 mA +/- 30 mA 4...20 mA +/- 30 V +/- 10 V +/- 30 V +/- 5 V +/- 30 V 0...10 V +/- 30 V 0...5 V +/- 30 V 1...5 V +/- 30 mA +/- 20 mA
Input impedance	250 Ohm
Precision of internal conversion resistor	0.1 % - 15 ppm/°C
Type of filter	First order digital filtering
Fast read cycle time	1 ms + 1 ms x number of channels used
Nominal read cycle time	9 ms for 8 channels

Excluding VAT and subject to change. Please check with your local distributor through "Where to buy"

<b>Measurement error</b>	0.15 % of full scale +/- 20 mA 25 °C 0.15 % of full scale 0...20 mA 25 °C 0.15 % of full scale 4...20 mA 25 °C 0.075 % of full scale +/- 10 V 25 °C 0.075 % of full scale 0...10 V 25 °C 0.075 % of full scale 0...5 V 25 °C 0.075 % of full scale 1...5 V 25 °C 0.075 % of full scale +/- 5 V 25 °C <= 0.1 % of full scale +/- 10 V - 25...70 °C <= 0.1 % of full scale +/- 5 V - 25...70 °C <= 0.1 % of full scale 0...10 V - 25...70 °C <= 0.1 % of full scale 0...5 V - 25...70 °C <= 0.1 % of full scale 1...5 V - 25...70 °C <= 0.3 % of full scale +/- 20 mA - 25...70 °C <= 0.3 % of full scale 0...20 mA - 25...70 °C <= 0.3 % of full scale 4...20 mA - 25...70 °C
<b>Temperature drift</b>	30 ppm/°C +/- 10 V 30 ppm/°C +/- 5 V 30 ppm/°C 0...10 V 30 ppm/°C 0...5 V 30 ppm/°C 1...5 V 50 ppm/°C +/- 20 mA 50 ppm/°C 0...20 mA 50 ppm/°C 4...20 mA
<b>Recalibration</b>	Factory calibrated
<b>Minimum crosstalk attenuation</b>	80 dB
<b>Digital value format</b>	+/- 32767 in user scale +/- 10000 by default
<b>Isolation voltage</b>	1400 V DC between channels and ground 1400 V DC between channels and bus 50 V DC between channels
<b>Measurement resolution</b>	0.36 mV +/- 10 V 0.36 mV 0...10 V 0.36 mV 0...5 V 0.36 mV 1...5 V 0.36 mV +/- 5 V 1.4 µA +/- 20 mA 1.4 µA 0...20 mA 1.4 µA 4...20 mA
<b>Maximum conversion value</b>	+/- 11.4 V +/- 10 V +/- 11.4 V 0...10 V +/- 11.4 V 0...5 V +/- 11.4 V 1...5 V 0...30 mA +/- 20 mA 0...30 mA 0...20 mA 0...30 mA 4...20 mA 0...30 mA +/- 5 V
<b>Operating altitude</b>	0...2000 m 2000...5000 m with derating factor
<b>Status LED</b>	1 LED (green) RUN 1 LED per channel (green) channel diagnostic 1 LED (red) ERR 1 LED (red) I/O
<b>Net weight</b>	0.165 kg
<b>Power consumption in W</b>	0.55 W 24 V DC typical 1.01 W 24 V DC maximum 0.32 W 3.3 V DC typical 0.48 W 3.3 V DC maximum

## Environment

<b>Vibration resistance</b>	3 gn
<b>Shock resistance</b>	30 gn
<b>Ambient air temperature for storage</b>	-40...85 °C

<b>Ambient air temperature for operation</b>	-25...70 °C
<b>Relative humidity</b>	5...95 % at 55 °C without condensation
<b>IP degree of protection</b>	IP20
<b>Product certifications</b>	CE EAC IEC-Ex ATEX RCM UL Merchant Navy CSA
<b>Standards</b>	CSA C22.2 No 61010-2-201 EN/IEC 61131-2 UL 61010-2-201 EN/IEC 61010-2-201
<b>Environmental characteristic</b>	Corrosion resistance Dust resistant
<b>Protective treatment</b>	Conformal coating Humiseal 1A33 TC



## Environmental Data

Schneider Electric aims to achieve Net Zero status by 2050 through supply chain partnerships, lower impact materials, and circularity via our ongoing “Use Better, Use Longer, Use Again” campaign to extend product lifetimes and recyclability.

[Environmental Data explained >](#)

[How we assess product sustainability >](#)

### Use Longer



#### Lifetime extension

Repair

No

Dimensions Drawings

Modules Mounted on Racks

---

Dimensions



(1) With removable terminal block (cage, screw or spring).

(2) With FCN connector.

(3) On AM1 ED rail: 35 mm wide, 15 mm deep. Only possible with BMXXBP0400/0400H/0600/0600H/0800/0800H rack.

Rack references	a in mm	a in in.
BMXXBP0400 and BMXXBP0400H	242.4	09.54
BMXXBP0600 and BMXXBP0600H	307.6	12.11
BMXXBP0800 and BMXXBP0800H	372.8	14.68
BMXXBP1200 and BMXXBP1200H	503.2	19.81

Connections and Schema

Wiring Diagram

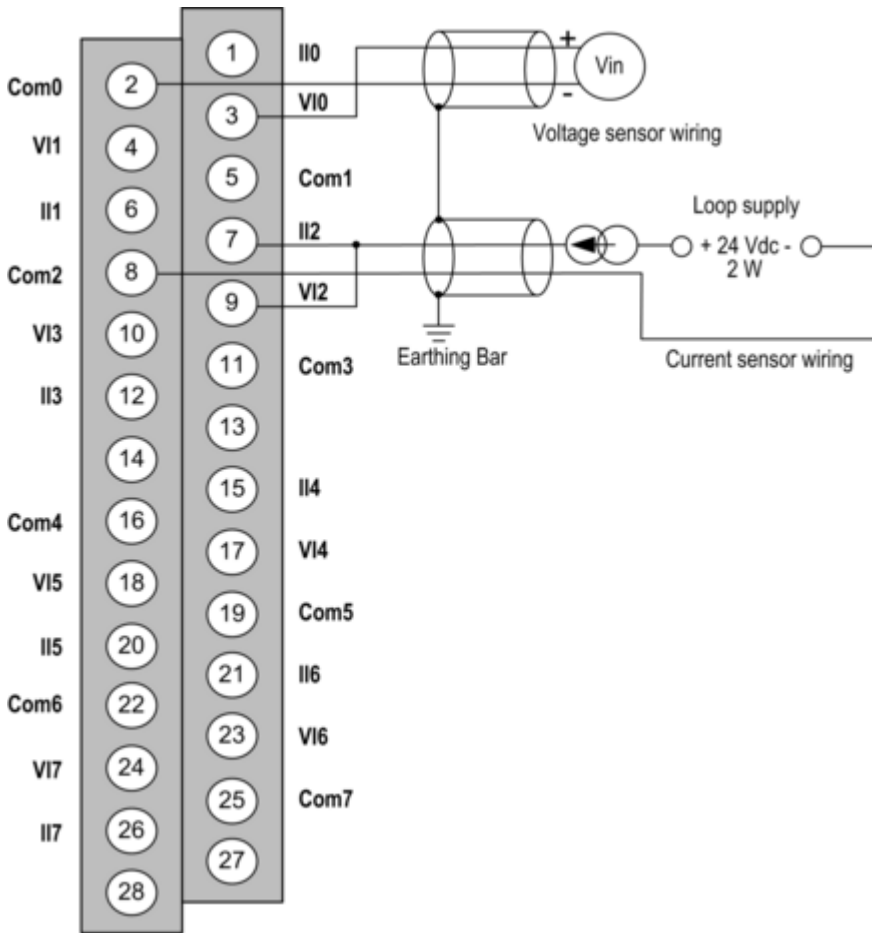

**VIx** + pole input for channel x.

**COMx** - pole input for channel x, COMx are connected together internally.

**IIx** current reading resistor + input.

**Channel 0** voltage sensor.

**Channel 1** 2-wire current sensor.