

# Product datasheet

Specifications



3-phase stepper motor - 2.26 Nm - shaft Ø 12 mm - L = 68 mm - with brake - conn

BRS397H660FCA

⚠ Discontinued on: 23 Oct 2020

⚠ Discontinued

## Main

Range compatibility	Lexium SD3
Product or component type	Motion control motor
Device short name	BRS3
Maximum mechanical speed	3000 rpm
Motor type	3-phase stepper motor
Number of motor poles	6
Supply voltage limits	34 V AC 48 V DC
Mounting support	Flange
Motor flange size	85 mm
Length	157 mm
Centring collar diameter	60 mm

## Complementary

Centring collar depth	2 mm
Number of mounting holes	4
Mounting holes diameter	6.5 mm
Circle diameter of the mounting holes	98.99 mm
Electrical connection	Connector
Holding brake	With
Shaft end	Woodruff key
Second shaft	Without second shaft end
Shaft diameter	12 mm
Shaft length	30 mm
Nominal torque	2 N.m
Holding torque	2.26 N.m
Rotor inertia	1.1 kg.cm <sup>2</sup>
Resolution	1.8 °, 0.9 °, 0.72 °, 0.36 °, 0.18 °, 0.09 °, 0.072 °, 0.036 ° step angle 200, 400, 500, 1000, 2000, 4000, 5000, 10000 steps number of full steps per revolution
Accuracy error	+/- 6 arc min
Maximum starting frequency	5 kHz

<b>[In] rated current</b>	5.8 A
<b>Resistance</b>	0.35 Ohm (winding)
<b>Time constant</b>	7 ms
<b>Maximum radial force Fr</b>	100 N (first shaft end) 50 N (second shaft end)
<b>Maximum axial force Fa</b>	175 N (tensile force) 30 N (force pressure)
<b>Service life in hours</b>	20000 h (bearing)
<b>Angular acceleration</b>	200000 rad/s <sup>2</sup>
<b>Net weight</b>	2.1 kg

## Environment

<b>Standards</b>	IEC 60072-1 EN 50347
<b>Type of cooling</b>	Natural convection
<b>Ambient air temperature for operation</b>	-25...40 °C
<b>Ambient air temperature for storage</b>	-25...70 °C
<b>Operating altitude</b>	<= 1000 m without power derating
<b>Relative humidity</b>	15...85 % without condensation
<b>Vibration resistance</b>	20 m/s <sup>2</sup> maximum A conforming to EN/IEC 60034-14
<b>IP degree of protection</b>	IP56 total except shaft bushing: conforming to EN/IEC 60034-5 IP41 shaft bushing without shaft seal ring: conforming to EN/IEC 60034-5
<b>Temperature class</b>	F winding conforming to IEC/EN 60034-1

## Packing Units

<b>Unit Type of Package 1</b>	PCE
<b>Number of Units in Package 1</b>	1
<b>Package 1 Height</b>	10.4 cm
<b>Package 1 Width</b>	18 cm
<b>Package 1 Length</b>	36.5 cm
<b>Package 1 Weight</b>	8.1 kg

## Contractual warranty

<b>Warranty (in months)</b>	18
-----------------------------	----



## Environmental Data

Schneider Electric aims to achieve Net Zero status by 2050 through supply chain partnerships, lower impact materials, and circularity via our ongoing “Use Better, Use Longer, Use Again” campaign to extend product lifetimes and recyclability.

[Environmental Data explained >](#)

[How we assess product sustainability >](#)

### Use Better



#### Materials and Substances

EU RoHS Directive

[Compliant By Exemption](#)

PVC free

Yes

### Use Longer



#### Lifetime extension

Repair

No

### Use Again



#### Repack and remanufacture

End of life manual availability

No need of specific recycling operations

WEEE Label



The product must be disposed on European Union markets following specific waste collection and never end up in rubbish bins

Dimensions Drawings

Dimensions

3-Phase Stepper Motor in Connector Version

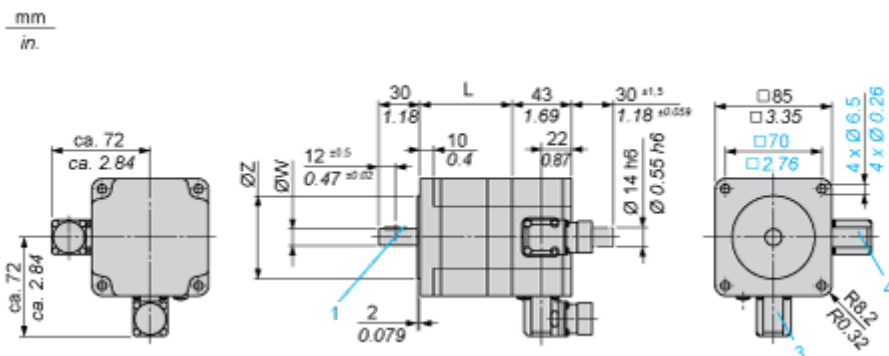

- 3: Motor connection 6 poles
- 4: Motor connection (optional) 12 poles

Holding Brake

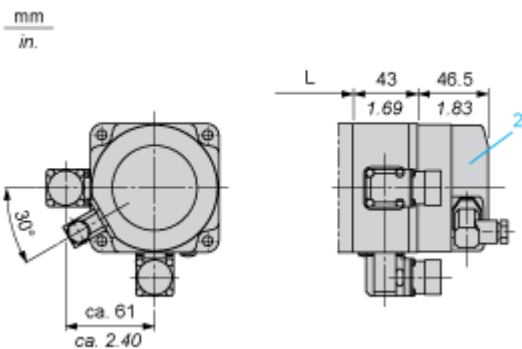

- 2: Holding brake (optional)

Dimensions in mm

L	Shaft diameter ØW	Centring collar ØZ	Woodruff key DIN 6888 (1)
67.5 (+0.6) (-0.8)	12 h6	60 h8	4 x 6.5

Dimensions in in.

L	Shaft diameter ØW	Centring collar ØZ	Woodruff key DIN 6888 (1)
2.66 (+0.023) (-0.031)	0.47 h6	2.36 h8	0.16 x 0.25

Connections and Schema

Wiring Diagram of Holding Brake

---

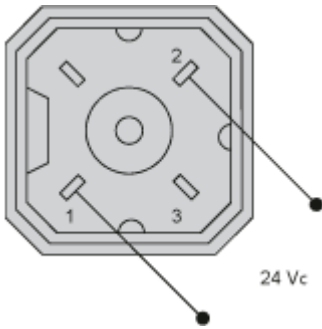

The connector is part of the scope of delivery. Connector designation: Hirschmann type G4 A 5M

Performance Curves

Torque Characteristics

Measurement at 1000 Steps/Revolution, Nominal Voltage DC Bus  $U_N$  and Phase Current  $I_N$

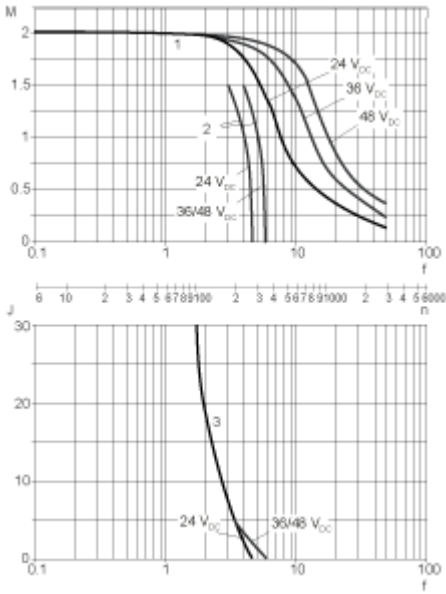

M : Torque in Nm

n : Speed in rpm

f : Frequency in kHz

J : Rotor inertia in kg.cm<sup>2</sup>

1 : Pull-out torque

2 : Pull-in torque

3 : Maximum load inertia