

SIPROTEC 4 7SJ62 Multifunction Protection Relay



Fig. 5/76
SIPROTEC 7SJ62
multifunction protection relay

Description

The SIPROTEC 4 7SJ62 relays can be used for line protection of high and medium voltage networks with earthed (grounded), low-resistance earthed, isolated or compensated neutral point. With regard to motor protection, the SIPROTEC 4 7SJ62 is suitable for asynchronous machines of all sizes. The relay performs all functions of backup protection supplementary to transformer differential protection.

The relay provides control of the circuit-breaker, further switching devices and automation functions. The integrated programmable logic (CFC) allows the user to implement their own functions, e. g. for the automation of switchgear (interlocking). The user is also allowed to generate user-defined messages.

The flexible communication interfaces are open for modern communication architectures with control systems.

Function overview

Protection functions

- Time-overcurrent protection (definite-time/inverse-time/user-def.)
- Directional time-overcurrent protection (definite-time/inverse-time/user-def.)
- Sensitive dir./non-dir. earth-fault detection
- Displacement voltage
- Intermittent earth-fault protection
- High-impedance restricted earth fault
- Inrush restraint
- Motor protection
 - Undercurrent monitoring
 - Starting time supervision
 - Restart inhibit
 - Locked rotor
- Overload protection
- Temperature monitoring
- Under-/overvoltage protection
- Under-/overfrequency protection
- Breaker failure protection
- Negative-sequence protection
- Phase-sequence monitoring
- Auto-reclosure
- Fault locator
- Lockout

Control functions/programmable logic

- Commands f. ctrl of CB and of isolators
- Control via keyboard, binary inputs, DIGSI 4 or SCADA system
- User-defined logic with CFC (e.g. interlocking)

Monitoring functions

- Operational measured values V, I, f
- Energy metering values W_p, W_q
- Circuit-breaker wear monitoring
- Slave pointer
- Trip circuit supervision
- Fuse failure monitor
- 8 oscillographic fault records

Communication interfaces

- System interface
 - IEC 60870-5-103/ IEC 61850
 - PROFIBUS-FMS/-DP
 - DNP 3.0/MODBUS RTU
- Service interface for DIGSI 4 (modem)
- Front interface for DIGSI 4
- Time synchronization via IRIG B/DCF77

Hardware

- 4 current transformers
- 3 voltage transformers
- 8/11 binary inputs
- 8/6 output relays

Application

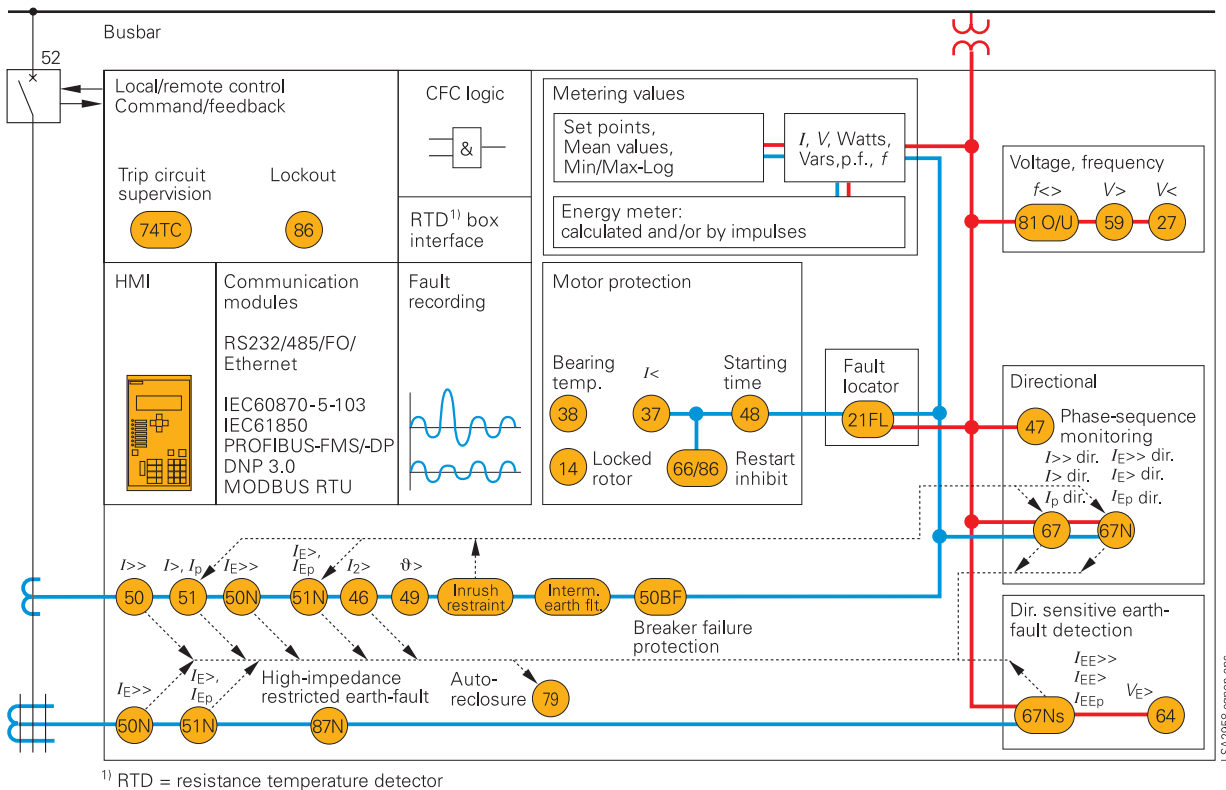

LSA2956-cjpein.eps

Fig. 5/77 Function diagram

The SIPROTEC 4 7SJ62 unit is a numerical protection relay that also performs control and monitoring functions and therefore supports the user in cost-effective power system management, and ensures reliable supply of electric power to the customers. Local operation has been designed according to ergonomic criteria. A large, easy-to-read display was a major design aim.

Control

The integrated control function permits control of disconnect devices, earthing switches or circuit-breakers via the integrated operator panel, binary inputs, DIGSI 4 or the control and protection system (e.g. SICAM). A full range of command processing functions is provided.

Programmable logic

The integrated logic characteristics (CFC) allow the user to implement their own functions for automation of switchgear (interlocking) or a substation via a graphic user interface. The user can also generate user-defined messages.

Line protection

The 7SJ62 units can be used for line protection of high and medium-voltage networks with earthed (grounded), low-resistance earthed, isolated or compensated neutral point.

Motor protection

When protecting motors, the 7SJ62 relay is suitable for asynchronous machines of all sizes.

Transformer protection

The relay performs all functions of backup protection supplementary to transformer differential protection. The inrush suppression effectively prevents tripping by inrush currents.

The high-impedance restricted earth-fault protection detects short-circuits and insulation faults on the transformer.

Backup protection

The 7SJ62 can be used universally for backup protection.

Metering values

Extensive measured values, limit values and metered values permit improved system management.

Application

ANSI No.	IEC	Protection functions
50, 50N	$I>, I>>, I_E>, I_E>>$	Definite time-overcurrent protection (phase/neutral)
51, 51N	I_p, I_{Ep}	Inverse time-overcurrent protection (phase/neutral)
67, 67N	$I_{dir>}, I_{dir>>}, I_{p\ dir}$ $I_{E\ dir>}, I_{E\ dir>>}, I_{Ep\ dir}$	Directional time-overcurrent protection (definite/inverse, phase/neutral), Directional comparison protection
67Ns/50Ns	$I_{EE>}, I_{EE>>}, I_{EEp}$	Directional/non-directional sensitive earth-fault detection
–		Cold load pick-up (dynamic setting change)
59N/64	$V_E, V_0>$	Displacement voltage, zero-sequence voltage
–	$I_{IE>}$	Intermittent earth fault
87N		High-impedance restricted earth-fault protection
50BF		Breaker failure protection
79		Auto-reclosure
46	$I_2>$	Phase-balance current protection (negative-sequence protection)
47	$V_2>, \text{phase-sequence}$	Unbalance-voltage protection and/or phase-sequence monitoring
49	$\vartheta>$	Thermal overload protection
48		Starting time supervision
14		Locked rotor protection
66/86		Restart inhibit
37	$I<$	Undercurrent monitoring
38		Temperature monitoring via external device (RTD-box), e.g. bearing temperature monitoring
27, 59	$V<, V>$	Undervoltage/overvoltage protection
81O/U	$f>, f<$	Overfrequency/underfrequency protection
21FL		Fault locator

Construction

Connection techniques and housing with many advantages

1/3-rack sizes is the available housing width of the 7SJ62 relays, referred to a 19" module frame system. This means that previous models can always be replaced. The height is a uniform 244 mm for flush-mounting housings and 266 mm for surface-mounting housing for all housing widths. All cables can be connected with or without ring lugs.

In the case of surface mounting on a panel, the connection terminals are located above and below in the form of screw-type terminals. The communication interfaces are located in a sloped case at the top and bottom of the housing.



Fig. 5/78 Rear view with screw-type terminals

Protection functions

Time-overcurrent protection
(ANSI 50, 50N, 51, 51N)

This function is based on the phase-selective measurement of the three phase currents and the earth current (four transformers). Two definite-time overcurrent protection elements (DMT) exist both for the phases and for the earth. The current threshold and the delay time can be set within a wide range. In addition, inverse-time overcurrent protection characteristics (IDMTL) can be activated.

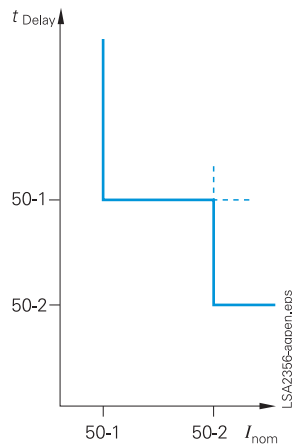

Fig. 5/79
Definite-time overcurrent protection

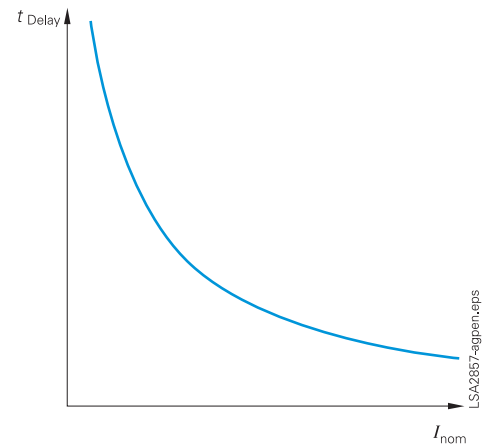

Fig. 5/80
Inverse-time overcurrent protection

Available inverse-time characteristics

Characteristics acc. to	ANSI/IEEE	IEC 60255-3
Inverse	•	•
Short inverse	•	
Long inverse	•	•
Moderately inverse	•	
Very inverse	•	•
Extremely inverse	•	•

Reset characteristics

For easier time coordination with electromechanical relays, reset characteristics according to ANSI C37.112 and IEC 60255-3 /BS 142 standards are applied. When using the reset characteristic (disk emulation), a reset process is initiated after the fault current has disappeared. This reset process corresponds to the reverse movement of the Ferraris disk of an electromechanical relay (thus: disk emulation).

User-definable characteristics

Instead of the predefined time characteristics according to ANSI, tripping characteristics can be defined by the user for phase and earth units separately. Up to 20 current/time value pairs may be programmed. They are set as pairs of numbers or graphically in DIGSI 4.

Inrush restraint

The relay features second harmonic restraint. If the second harmonic is detected during transformer energization, pickup of non-directional and directional normal elements are blocked.

Cold load pickup/dynamic setting change

For directional and non-directional time-overcurrent protection functions the initiation thresholds and tripping times can be switched via binary inputs or by time control.

Protection functions

Directional time-overcurrent protection (ANSI 67, 67N)

Directional phase and earth protection are separate functions. They operate in parallel to the non-directional overcurrent elements. Their pickup values and delay times can be set separately. Definite-time and inverse-time characteristics are offered. The tripping characteristic can be rotated about ± 180 degrees.

By means of voltage memory, directionality can be determined reliably even for close-in (local) faults. If the switching device closes onto a fault and the voltage is too low to determine direction, directionality (directional decision) is made with voltage from the voltage memory. If no voltage exists in the memory, tripping occurs according to the coordination schedule.

For earth protection, users can choose whether the direction is to be determined via zero-sequence system or negative-sequence system quantities (selectable). Using negative-sequence variables can be advantageous in cases where the zero voltage tends to be very low due to unfavorable zero-sequence impedances.

Directional comparison protection (cross-coupling)

It is used for selective protection of sections fed from two sources with instantaneous tripping, i.e. without the disadvantage of time coordination. The directional comparison protection is suitable if the distances between the protection stations are not significant and pilot wires are available for signal transmission. In addition to the directional comparison protection, the directional coordinated time-overcurrent protection is used for complete selective backup protection. If operated in a closed-circuit connection, an interruption of the transmission line is detected.

(Sensitive) directional earth-fault detection (ANSI 64, 67Ns, 67N)

For isolated-neutral and compensated networks, the direction of power flow in the zero sequence is calculated from the zero-sequence current I_0 and zero-sequence voltage V_0 .

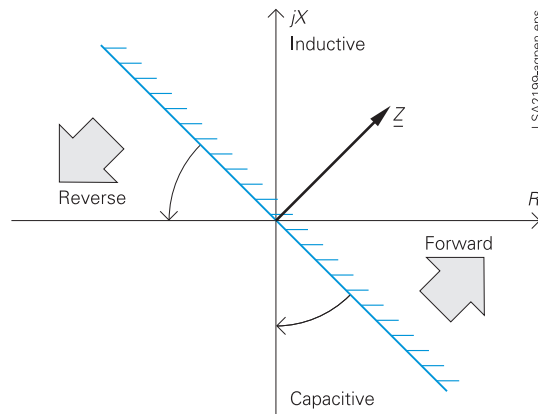

Fig. 5/81
Directional characteristic of the directional time-overcurrent protection

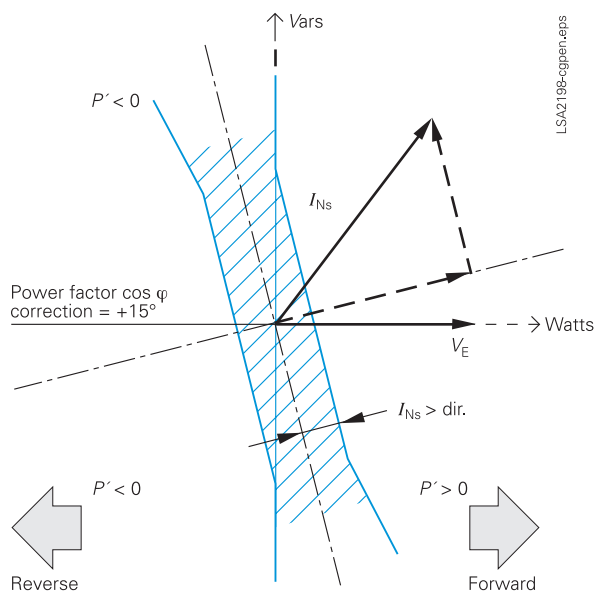

Fig. 5/82
Directional determination using cosine measurements for compensated networks

For networks with an isolated neutral, the reactive current component is evaluated; for compensated networks, the active current component or residual resistive current is evaluated. For special network conditions, e.g. high-resistance earthed networks with ohmic-capacitive earth-fault current or low-resistance earthed networks with ohmic-inductive current, the tripping characteristics can be rotated approximately ± 45 degrees.

Two modes of earth-fault direction detection can be implemented: tripping or "signalling only mode".

It has the following functions:

- TRIP via the displacement voltage V_E .
- Two instantaneous elements or one instantaneous plus one user-defined characteristic.

- Each element can be set in forward, reverse, or non-directional.
- The function can also be operated in the insensitive mode as an additional short-circuit protection.

(Sensitive) earth-fault detection (ANSI 50Ns, 51Ns / 50N, 51N)

For high-resistance earthed networks, a sensitive input transformer is connected to a phase-balance neutral current transformer (also called core-balance CT).

The function can also be operated in the insensitive mode as an additional short-circuit protection.

Protection functions

Intermittent earth-fault protection

Intermittent (re-striking) faults occur due to insulation weaknesses in cables or as a result of water penetrating cable joints. Such faults either simply cease at some stage or develop into lasting short-circuits. During intermittent activity, however, star-point resistors in networks that are impedance-earthed may undergo thermal overloading. The normal earth-fault protection cannot reliably detect and interrupt the current pulses, some of which can be very brief.

The selectivity required with intermittent earth faults is achieved by summing the duration of the individual pulses and by triggering when a (settable) summed time is reached. The response threshold $I_{IE>}$ evaluates the r.m.s. value, referred to one systems period.

Phase-balance current protection (ANSI 46) (Negative-sequence protection)

In line protection, the two-element phase-balance current/negative-sequence protection permits detection on the high side of high-resistance phase-to-phase faults and phase-to-earth faults that are on the low side of a transformer (e.g. with the switch group Dy 5). This provides backup protection for high-resistance faults beyond the transformer.

Breaker failure protection (ANSI 50BF)

If a faulted portion of the electrical circuit is not disconnected upon issuance of a trip command, another command can be initiated using the breaker failure protection which operates the circuit-breaker, e.g. of an upstream (higher-level) protection relay. Breaker failure is detected if, after a trip command, current is still flowing in the faulted circuit. As an option, it is possible to make use of the circuit-breaker position indication.

High-impedance restricted earth-fault protection (ANSI 87N)

The high-impedance measurement principle is an uncomplicated and sensitive method for detecting earth faults, especially on transformers. It can also be applied to motors, generators and reactors when these are operated on an earthed network.

When the high-impedance measurement principle is applied, all current transformers in the protected area are connected in parallel and operated on one common resistor of relatively high R whose voltage is measured (see Fig. 5/83). In the case of 7SJ6 units, the voltage is measured by detecting the current through the (external) resistor R at the sensitive current measurement input I_{EE} . The varistor V serves to limit the voltage in the event of an internal fault. It cuts off the high momentary voltage spikes occurring at transformer saturation. At the same time, this results in smoothing of the voltage without any noteworthy reduction of the average value. If no faults have occurred and in the event of external faults, the system is at equilibrium, and the voltage through the resistor is approximately zero. In the event of internal faults, an imbalance occurs which leads to a voltage and a current flow through the resistor R .

The current transformers must be of the same type and must at least offer a separate core for the high-impedance restricted earth-fault protection. They must in particular have the same transformation ratio and an approximately identical knee-point voltage. They should also demonstrate only minimal measuring errors.

Auto-reclosure (ANSI 79)

Multiple reclosures can be defined by the user and lockout will occur if a fault is present after the last reclosure. The following functions are possible:

- 3-pole ARC for all types of faults
- Separate settings for phase and earth faults
- Multiple ARC, one rapid auto-reclosure (RAR) and up to nine delayed auto-reclosures (DAR)
- Starting of the ARC depends on the trip command selection (e.g. 46, 50, 51, 67)
- Blocking option of the ARC via binary inputs
- ARC can be initiated externally or via CFC
- The directional and non-directional elements can either be blocked or operated non-delayed depending on the auto-reclosure cycle
- Dynamic setting change of the directional and non-directional elements can be activated depending on the ready AR

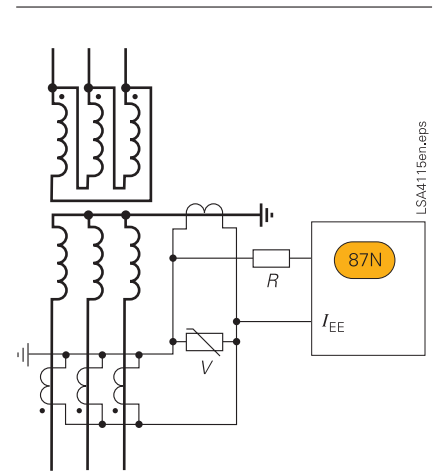

Fig. 5/83 High-impedance restricted earth-fault protection

Thermal overload protection (ANSI 49)

For protecting cables and transformers, an overload protection with an integrated pre-warning element for temperature and current can be applied. The temperature is calculated using a thermal homogeneous-body model (according to IEC 60255-8), which takes account both of the energy entering the equipment and the energy losses. The calculated temperature is constantly adjusted accordingly. Thus, account is taken of the previous load and the load fluctuations.

For thermal protection of motors (especially the stator) a further time constant can be set so that the thermal ratios can be detected correctly while the motor is rotating and when it is stopped. The ambient temperature or the temperature of the coolant can be detected serially via an external temperature monitoring box (resistance-temperature detector box, also called RTD-box). The thermal replica of the overload function is automatically adapted to the ambient conditions. If there is no RTD-box it is assumed that the ambient temperatures are constant.

Settable dropout delay times

If the devices are used in parallel with electromechanical relays in networks with intermittent faults, the long dropout times of the electromechanical devices (several hundred milliseconds) can lead to problems in terms of time grading. Clean time grading is only possible if the dropout time is approximately the same. This is why the parameter of dropout times can be defined for certain functions such as time-overcurrent protection, earth short-circuit and phase-balance current protection.

Protection functions

Motor protection

Restart inhibit (ANSI 66/86)

If a motor is started up too many times in succession, the rotor can be subject to thermal overload, especially the upper edges of the bars. The rotor temperature is calculated from the stator current. The reclosing lockout only permits start-up of the motor if the rotor has sufficient thermal reserves for a complete start-up (see Fig. 5/84).

Emergency start-up

This function disables the reclosing lockout via a binary input by storing the state of the thermal replica as long as the binary input is active. It is also possible to reset the thermal replica to zero.

Temperature monitoring (ANSI 38)

Up to two temperature monitoring boxes with a total of 12 measuring sensors can be used for temperature monitoring and detection by the protection relay. The thermal status of motors, generators and transformers can be monitored with this device. Additionally, the temperature of the bearings of rotating machines are monitored for limit value violation. The temperatures are being measured with the help of temperature detectors at various locations of the device to be protected. This data is transmitted to the protection relay via one or two temperature monitoring boxes (see "Accessories", page 5/113).

Starting time supervision (ANSI 48/14)

Starting time supervision protects the motor against long unwanted start-ups that might occur in the event of excessive load torque or excessive voltage drops within the motor, or if the rotor is locked. Rotor temperature is calculated from measured stator current. The tripping time is calculated according to the following equation:

for $I > I_{\text{MOTOR START}}$

$$t = \left(\frac{I_A}{I} \right)^2 \cdot T_A$$

I = Actual current flowing

$I_{\text{MOTOR START}}$ = Pickup current to detect a motor start

t = Tripping time

I_A = Rated motor starting current

T_A = Tripping time at rated motor starting current

1) The 45 to 55, 55 to 65 Hz range is available for $f_N = 50/60$ Hz.

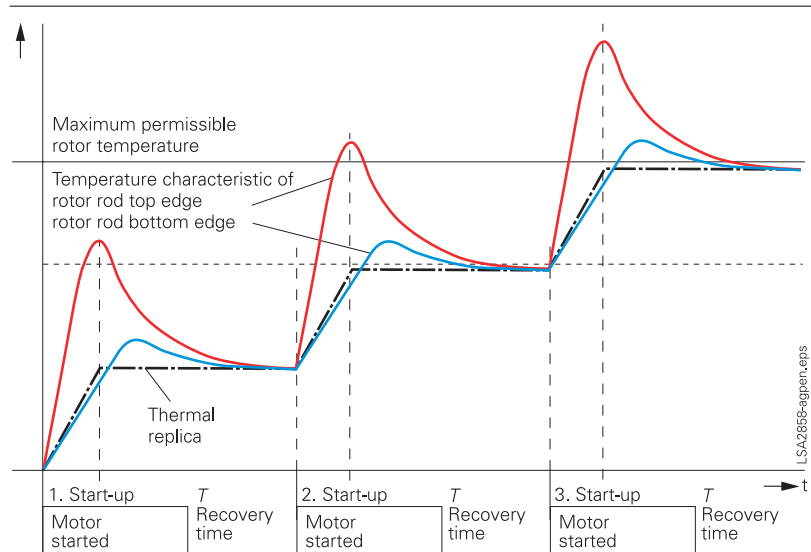

Fig. 5/84

If the trip time is rated according to the above formula, even a prolonged start-up and reduced voltage (and reduced start-up current) will be evaluated correctly. The tripping time is inverse (current dependent).

A binary signal is set by a speed sensor to detect a blocked rotor. An instantaneous tripping is effected.

Phase-balance current protection (ANSI 46) (Negative-sequence protection)

The negative-sequence / phase-balance current protection detects a phase failure or load unbalance due to network asymmetry and protects the rotor from impermissible temperature rise.

Undercurrent monitoring (ANSI 37)

With this function, a sudden drop in current, which can occur due to a reduced motor load, is detected. This may be due to shaft breakage, no-load operation of pumps or fan failure.

Voltage protection

Overvoltage protection (ANSI 59)

The two-element overvoltage protection detects unwanted network and machine overvoltage conditions. The function can operate either with phase-to-phase voltage (default) or with the negative phase-sequence system voltage. Three-phase and single-phase connections are possible.

Undervoltage protection (ANSI 27)

The two-element undervoltage protection provides protection against dangerous voltage drops (especially for electric machines). Applications include the isolation of generators or motors from the network to avoid undesired operating states and a possible loss of stability. Proper operating conditions of electrical machines are best evaluated with the positive-sequence quantities. The protection function is active over a wide frequency range (45 to 55, 55 to 65 Hz)¹⁾. Even when falling below this frequency range the function continues to work, however, with a greater tolerance band.

The function can operate either with the positive phase-sequence system voltage (default) or with the phase-to-phase voltages, and can be monitored with a current criterion. Three-phase and single-phase connections are possible.

Frequency protection (ANSI 810/U)

Frequency protection can be used for overfrequency and underfrequency protection. Electric machines and parts of the system are protected from unwanted speed deviations. Unwanted frequency changes in the network can be detected and the load can be removed at a specified frequency setting.

Protection functions/Functions

Frequency protection can be used over a wide frequency range (45 to 55, 55 to 65 Hz)¹⁾. There are four elements (selectable as overfrequency or underfrequency) and each element can be delayed separately. Blocking of the frequency protection can be performed if using a binary input or by using an undervoltage element.

Fault locator (ANSI 21FL)

The fault locator specifies the distance to a fault location in kilometers or miles or the reactance of a second fault operation.

Circuit-breaker wear monitoring

Methods for determining circuit-breaker contact wear or the remaining service life of a circuit-breaker (CB) allow CB maintenance intervals to be aligned to their actual degree of wear. The benefit lies in reduced maintenance costs.

There is no mathematically exact method of calculating the wear or the remaining service life of circuit-breakers that takes into account the arc-chamber's physical conditions when the CB opens. This is why various methods of determining CB wear have evolved which reflect the different operator philosophies. To do justice to these, the devices offer several methods:

- ΣI
- ΣI^x , with $x = 1 \dots 3$

The devices additionally offer a new method for determining the remaining service life:

- Two-point method

The CB manufacturers double-logarithmic switching cycle diagram (see Fig. 5/85) and the breaking current at the time of contact opening serve as the basis for this method. After CB opening, the two-point method calculates the number of still possible switching cycles. To this end, the two points P1 and P2 only have to be set on the device. These are specified in the CB's technical data.

All of these methods are phase-selective and a limit value can be set in order to obtain an alarm if the actual value falls below or exceeds the limit value during determination of the remaining service life.

Customized functions (ANSI 32, 51V, 55, etc.)

Additional functions, which are not time critical, can be implemented via the CFC using measured values. Typical functions include reverse power, voltage controlled overcurrent, phase angle detection, and zero-sequence voltage detection.

Commissioning

Commissioning could hardly be easier and is fully supported by DIGSI 4. The status of the binary inputs can be read individually and the state of the binary outputs can be set individually. The operation of switching elements (circuit-breakers, disconnect devices) can be checked using the switching functions of the bay controller. The analog measured values are represented as wide-ranging operational measured values. To prevent transmission of information to the control center during maintenance, the bay controller communications can be disabled to prevent unnecessary data from being transmitted. During commissioning, all indications with test marking for test purposes can be connected to a control and protection system.

Test operation

During commissioning, all indications can be passed to an automatic control system for test purposes.

Control and automatic functions

Control

In addition to the protection functions, the SIPROTEC 4 units also support all control and monitoring functions that are required for operating medium-voltage or high-voltage substations.

The main application is reliable control of switching and other processes.

The status of primary equipment or auxiliary devices can be obtained from auxiliary contacts and communicated to the 7SJ62 via binary inputs. Therefore it is possible to detect and indicate both the OPEN and CLOSED position or a fault or intermediate circuit-breaker or auxiliary contact position.

The switchgear or circuit-breaker can be controlled via:

- integrated operator panel
- binary inputs
- substation control and protection system
- DIGSI 4

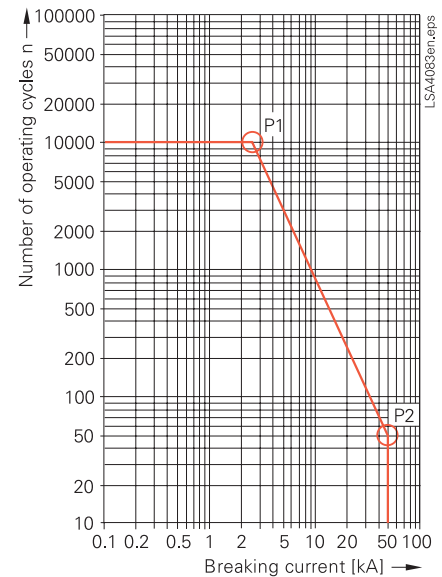

Fig. 5/85 CB switching cycle diagram

Automation / user-defined logic

With integrated logic, the user can set, via a graphic interface (CFC), specific functions for the automation of switchgear or substation. Functions are activated via function keys, binary input or via communication interface.

Switching authority

Switching authority is determined according to parameters, communication or by key-operated switch (when available). If a source is set to "LOCAL", only local switching operations are possible. The following sequence of switching authority is laid down: "LOCAL"; DIGSI PC program, "REMOTE".

Command processing

All the functionality of command processing is offered. This includes the processing of single and double commands with or without feedback, sophisticated monitoring of the control hardware and software, checking of the external process, control actions using functions such as runtime monitoring and automatic command termination after output. Here are some typical applications:

- Single and double commands using 1, 1 plus 1 common or 2 trip contacts
- User-definable bay interlocks
- Operating sequences combining several switching operations such as control of circuit-breakers, disconnectors and earthing switches

1) The 45 to 55, 55 to 65 Hz range is available for $f_N = 50/60$ Hz

Functions

- Triggering of switching operations, indications or alarm by combination with existing information

Assignment of feedback to command

The positions of the circuit-breaker or switching devices and transformer taps are acquired by feedback. These indication inputs are logically assigned to the corresponding command outputs. The unit can therefore distinguish whether the indication change is a consequence of switching operation or whether it is a spontaneous change of state.

Chatter disable

Chatter disable feature evaluates whether, in a configured period of time, the number of status changes of indication input exceeds a specified figure. If exceeded, the indication input is blocked for a certain period, so that the event list will not record excessive operations.

Indication filtering and delay

Binary indications can be filtered or delayed.

Filtering serves to suppress brief changes in potential at the indication input. The indication is passed on only if the indication voltage is still present after a set period of time. In the event of indication delay, there is a wait for a preset time. The information is passed on only if the indication voltage is still present after this time.

Indication derivation

A further indication (or a command) can be derived from an existing indication. Group indications can also be formed. The volume of information to the system interface can thus be reduced and restricted to the most important signals.

Switchgear cubicles for high/medium voltage

All units are designed specifically to meet the requirements of high/medium-voltage applications.

In general, no separate measuring instruments (e.g., for current, voltage, frequency, ...) or additional control components are necessary.

Measured values

The r.m.s. values are calculated from the acquired current and voltage along with the power factor, frequency, active and reactive power. The following functions are available for measured value processing:

- Currents I_{L1} , I_{L2} , I_{L3} , I_E , I_{EE} (67Ns)
- Voltages V_{L1} , V_{L2} , V_{L3} , V_{L1L2} , V_{L2L3} , V_{L3L1}
- Symmetrical components I_1 , I_2 , $3I_0$; V_1 , V_2 , V_0
- Power Watts, Vars, VA/P, Q, S (P , Q : total and phase selective)
- Power factor ($\cos \varphi$), (total and phase selective)
- Frequency
- Energy \pm kWh, \pm kVarh, forward and reverse power flow
- Mean as well as minimum and maximum current and voltage values
- Operating hours counter
- Mean operating temperature of overload function
- Limit value monitoring
Limit values are monitored using programmable logic in the CFC. Commands can be derived from this limit value indication.
- Zero suppression
In a certain range of very low measured values, the value is set to zero to suppress interference.

Metered values

For internal metering, the unit can calculate an energy metered value from the measured current and voltage values. If an external meter with a metering pulse output is available, the SIPROTEC 4 unit can obtain and process metering pulses via an indication input.

The metered values can be displayed and passed on to a control center as an accumulation with reset. A distinction is made between forward, reverse, active and reactive energy.



Fig. 5/86
NXAIR panel (air-insulated)

Communication

In terms of communication, the units offer substantial flexibility in the context of connection to industrial and power automation standards. Communication can be extended or added on thanks to modules for retrofitting on which the common protocols run. Therefore, also in the future it will be possible to optimally integrate units into the changing communication infrastructure, for example in Ethernet networks (which will also be used increasingly in the power supply sector in the years to come).

Serial front interface

There is a serial RS232 interface on the front of all the units. All of the unit's functions can be set on a PC by means of the DIGSI 4 protection operation program. Commissioning tools and fault analysis are also built into the program and are available through this interface.

Rear-mounted interfaces¹⁾

A number of communication modules suitable for various applications can be fitted in the rear of the flush-mounting housing. In the flush-mounting housing, the modules can be easily replaced by the user. The interface modules support the following applications:

- Time synchronization interface
All units feature a permanently integrated electrical time synchronization interface. It can be used to feed timing telegrams in IRIG-B or DCF77 format into the units via time synchronization receivers.
- System interface
Communication with a central control system takes place through this interface. Radial or ring type station bus topologies can be configured depending on the chosen interface. Furthermore, the units can exchange data through this interface via Ethernet and IEC 61850 protocol and can also be operated by DIGSI.
- Service interface
The service interface was conceived for remote access to a number of protection units via DIGSI. On all units, it can be an electrical RS232/RS485 or an optical interface. For special applications, a maximum of two temperature monitoring boxes (RTD-box) can be connected to this interface as an alternative.

1) For units in panel surface-mounting housings please refer to note on page 5/112.

System interface protocols (retrofittable)

IEC 61850 protocol

As of mid-2004, the Ethernet-based IEC 61850 protocol is the worldwide standard for protection and control systems used by power supply corporations. Siemens is the first manufacturer to support this standard. By means of this protocol, information can also be exchanged directly between bay units so as to set up simple masterless systems for bay and system interlocking. Access to the units via the Ethernet bus will also be possible with DIGSI.

IEC 60870-5-103 protocol

The IEC 60870-5-103 protocol is an international standard for the transmission of protective data and fault recordings. All messages from the unit and also control commands can be transferred by means of published, Siemens-specific extensions to the protocol.

PROFIBUS-FMS

PROFIBUS-FMS is an internationally standardized communication system (EN 50170) for efficient performance of communication tasks in the bay area. SIPROTEC 4 units use a profile specially optimized for protection and control requirements. DIGSI can also work on the basis of PROFIBUS-FMS. The units are linked to a SICAM automation system.

PROFIBUS-DP protocol

PROFIBUS-DP is the most widespread protocol in industrial automation. Via PROFIBUS-DP, SIPROTEC units make their information available to a SIMATIC controller or, in the control direction, receive commands from a central SIMATIC. Measured values can also be transferred.

MODBUS RTU protocol

This uncomplicated, serial protocol is mainly used in industry and by power supply corporations, and is supported by a number of unit manufacturers. SIPROTEC units function as MODBUS slaves, making their information available to a master or receiving information from it. A time-stamped event list is available.

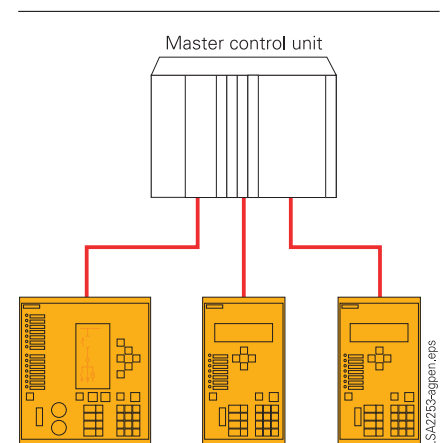

Fig. 5/87
IEC 60870-5-103: Radial fiber-optic connection

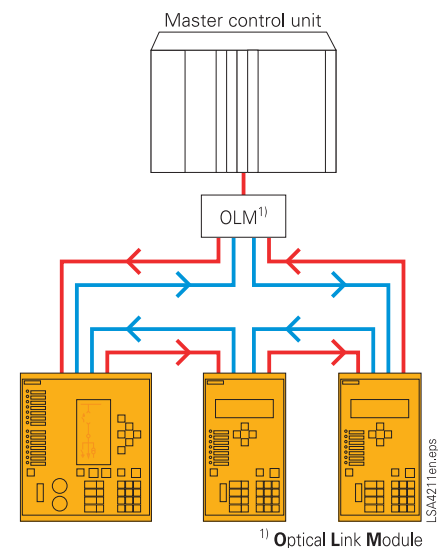

Fig. 5/88
PROFIBUS: Fiber-optic double ring circuit

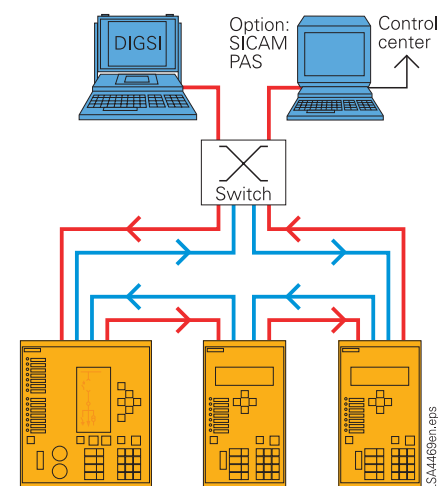

Fig. 5/89
Bus structure for station bus with Ethernet and IEC 61850, fiber-optic ring

Communication

DNP 3.0 protocol

Power supply corporations use the serial DNP 3.0 (Distributed Network Protocol) for the station and network control levels. SIPROTEC units function as DNP slaves, supplying their information to a master system or receiving information from it.

System solutions for protection and station control

Together with the SICAM power automation system, SIPROTEC 4 can be used with PROFIBUS-FMS. Over the low-cost electrical RS485 bus, or interference-free via the optical double ring, the units exchange information with the control system.

Units featuring IEC 60870-5-103 interfaces can be connected to SICAM in parallel via the RS485 bus or radially by fiber-optic link. Through this interface, the system is open for the connection of units of other manufacturers (see Fig. 5/87).

Because of the standardized interfaces, SIPROTEC units can also be integrated into systems of other manufacturers or in SIMATIC. Electrical RS485 or optical interfaces are available. The optimum physical data transfer medium can be chosen thanks to opto-electrical converters. Thus, the RS485 bus allows low-cost wiring in the cubicles and an interference-free optical connection to the master can be established.

For IEC 61850, an interoperable system solution is offered with SICAM PAS. Via the 100 Mb/s Ethernet bus, the units are linked with PAS electrically or optically to the station PC. The interface is standardized, thus also enabling direct connection of units of other manufacturers to the Ethernet bus. With IEC 61850, however, the units can also be used in other manufacturers' systems (see Fig. 5/89).

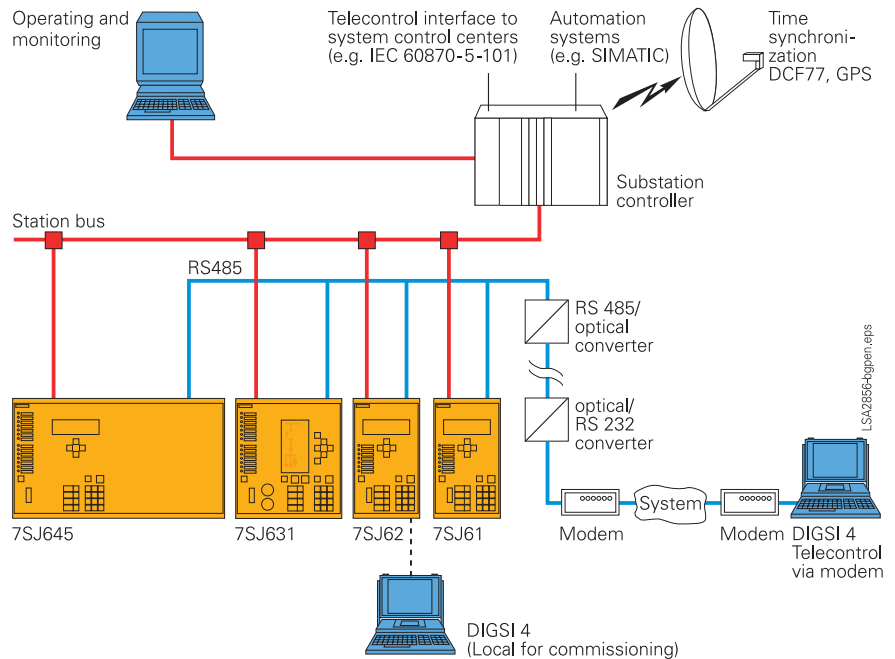

Fig. 5/90
System solution/communication

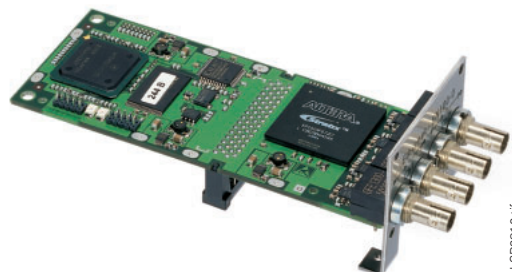

Fig. 5/91
Optical Ethernet communication module for IEC 61850 with integrated Ethernet-switch

Typical connections

■ Connection of current and voltage transformers

Standard connection

For earthed networks, the earth current is obtained from the phase currents by the residual current circuit.

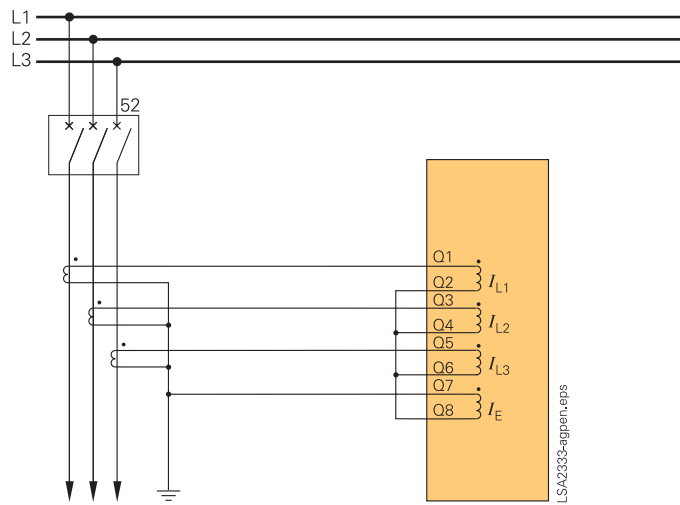

Fig. 5/92
Residual current circuit without directional element

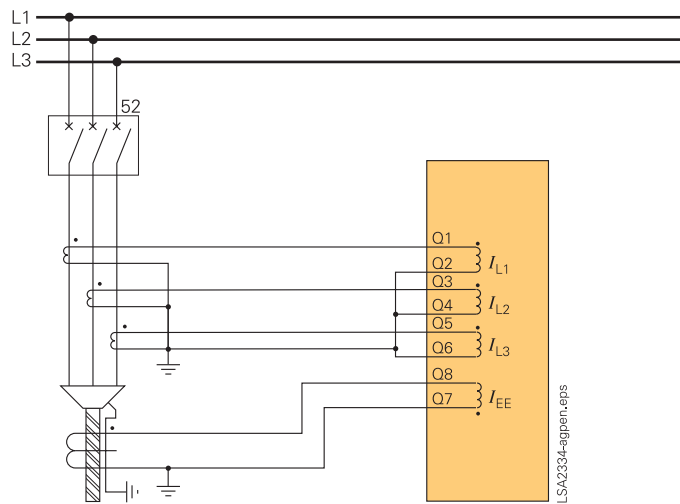

Fig. 5/93
Sensitive earth-current detection without directional element

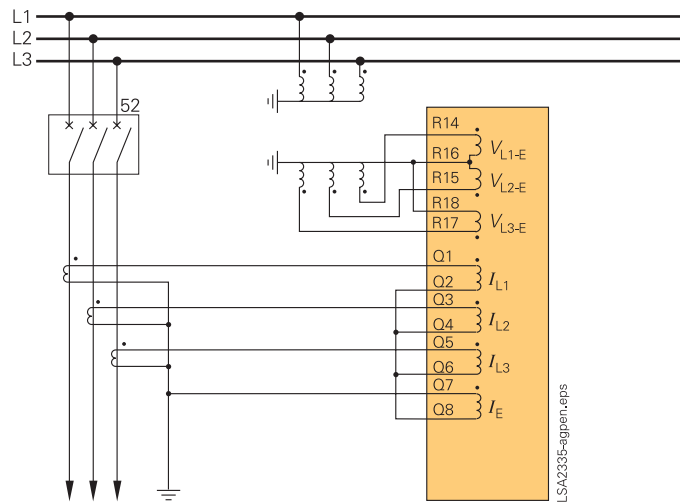

Fig. 5/94
Residual current circuit with directional element

Typical connections

Connection for compensated networks

The figure shows the connection of two phase-to-earth voltages and the V_E voltage of the open delta winding and a phase-balance neutral current transformer for the earth current. This connection maintains maximum precision for directional earth-fault detection and must be used in compensated networks.

Fig. 5/95 shows sensitive directional earth-fault detection.

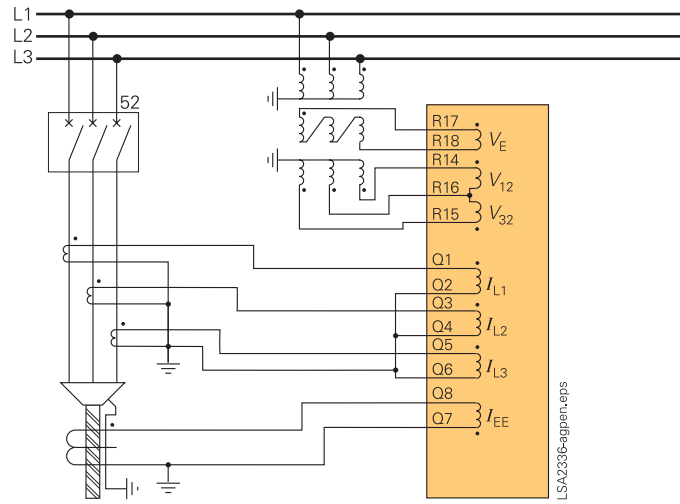

Fig. 5/95 Sensitive directional earth-fault detection with directional element for phases

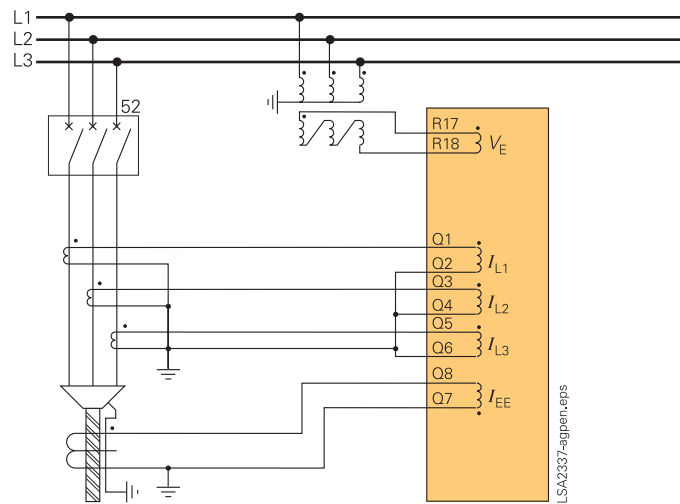

Fig. 5/96 Sensitive directional earth-fault detection

Connection for isolated-neutral or compensated networks only

If directional earth-fault protection is not used, the connection can be made with only two phase current transformers. Directional phase short-circuit protection can be achieved by using only two primary transformers.

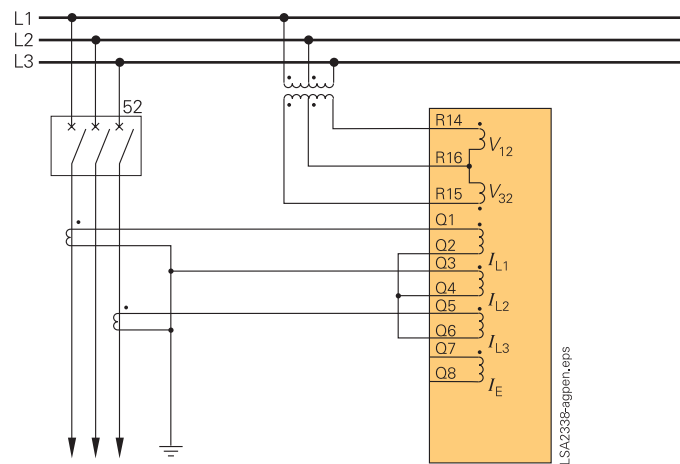

Fig. 5/97 Isolated-neutral or compensated networks

Typical applications

Overview of connection types

Type of network	Function	Current connection	Voltage connection
(Low-resistance) earthed network	Time-overcurrent protection phase/earth non-directional	Residual circuit, with 3 phase-current transformers required, phase-balance neutral current transformer possible	-
(Low-resistance) earthed networks	Sensitive earth-fault protection	Phase-balance neutral current transformers required	-
Isolated or compensated networks	Time-overcurrent protection phases non-directional	Residual circuit, with 3 or 2 phase current transformers possible	-
(Low-resistance) earthed networks	Time-overcurrent protection phases directional	Residual circuit, with 3 phase-current transformers possible	Phase-to-earth connection or phase-to-phase connection
Isolated or compensated networks	Time-overcurrent protection phases directional	Residual circuit, with 3 or 2 phase-current transformers possible	Phase-to-earth connection or phase-to-phase connection
(Low-resistance) earthed networks	Time-overcurrent protection earth directional	Residual circuit, with 3 phase-current transformers required, phase-balance neutral current transformers possible	Phase-to-earth connection required
Isolated networks	Sensitive earth-fault protection	Residual circuit, if earth current $> 0.05 I_N$ on secondary side, otherwise phase-balance neutral current transformers required	3 times phase-to-earth connection or phase-to-earth connection with open delta winding
Compensated networks	Sensitive earth-fault protection $\cos \varphi$ measurement	Phase-balance neutral current transformers required	Phase-to-earth connection with open delta winding required

5

■ Connection of circuit-breaker

Undervoltage releases

Undervoltage releases are used for automatic tripping of high-voltage motors.

Example:

DC supply voltage of control system fails and manual electric tripping is no longer possible.

Automatic tripping takes place when voltage across the coil drops below the trip limit. In Fig. 5/98, tripping occurs due to failure of DC supply voltage, by automatic opening of the live status contact upon failure of the protection unit or by short-circuiting the trip coil in event of network fault.

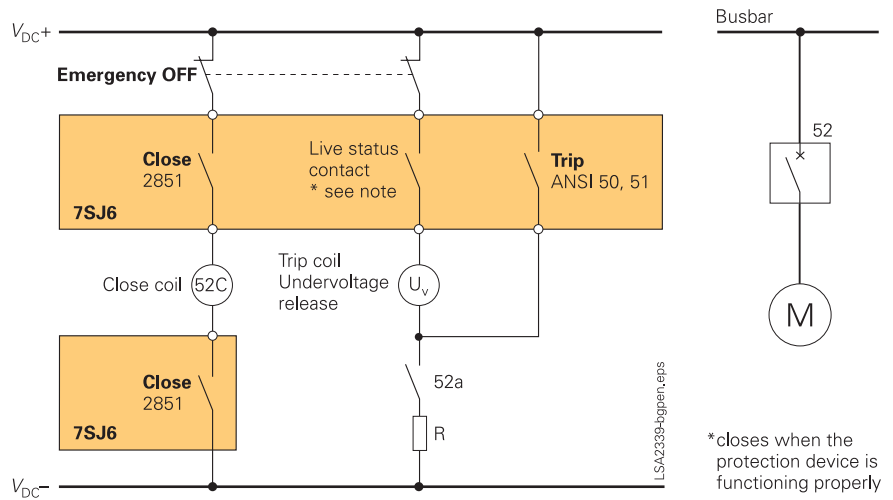

Fig. 5/98 Undervoltage release with make contact (50, 51)

*closes when the protection device is functioning properly

LSA2339-bqpen.eps

Typical applications

In Fig. 5/99 tripping is by failure of auxiliary voltage and by interruption of tripping circuit in the event of network failure. Upon failure of the protection unit, the tripping circuit is also interrupted, since contact held by internal logic drops back into open position.

Trip circuit supervision (ANSI 74TC)

One or two binary inputs can be used for monitoring the circuit-breaker trip coil including its incoming cables. An alarm signal occurs whenever the circuit is interrupted.

Lockout (ANSI 86)

All binary outputs can be stored like LEDs and reset using the LED reset key. The lockout state is also stored in the event of supply voltage failure. Reclosure can only occur after the lockout state is reset.

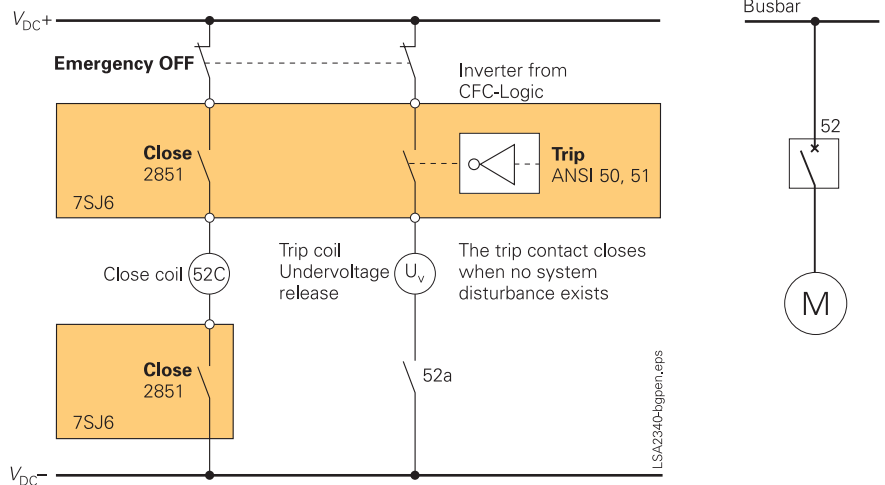

Fig. 5/99 Undervoltage trip with locking contact (trip signal 50 is inverted)

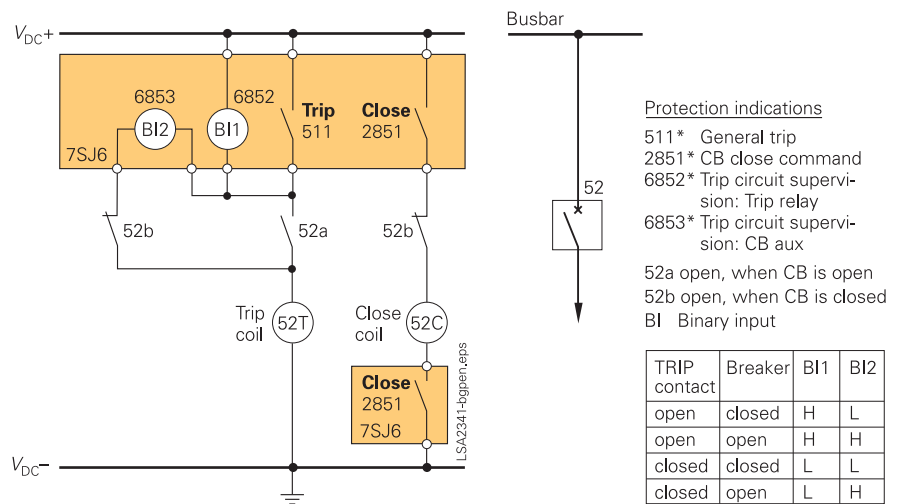

Fig. 5/100 Trip circuit supervision with 2 binary inputs

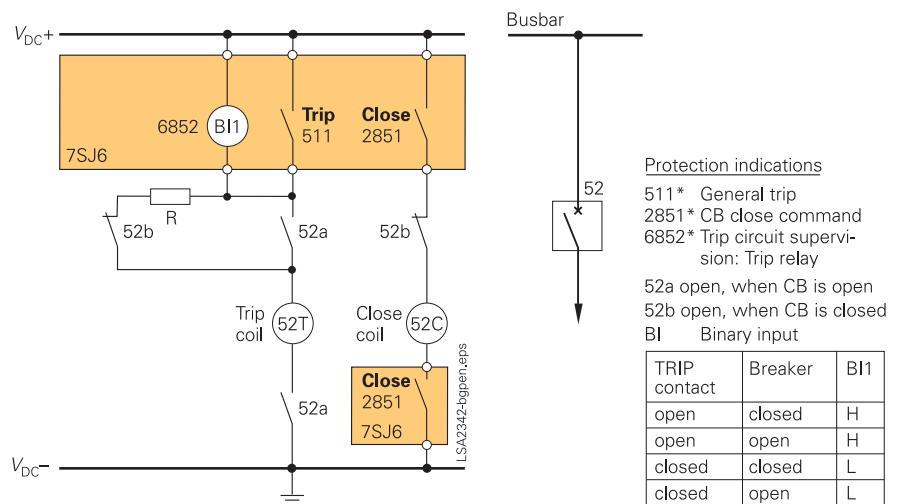

Fig. 5/101 Trip circuit supervision with 1 binary input

Technical data

General unit data	
Measuring circuits	
System frequency	50 / 60 Hz (settable)
Current transformer	
Rated current I_{nom}	1 or 5 A (settable)
Option: sensitive earth-fault CT	$I_{EE} < 1.6$ A
Power consumption at $I_{nom} = 1$ A at $I_{nom} = 5$ A for sensitive earth-fault CT at 1 A	Approx. 0.05 VA per phase Approx. 0.3 VA per phase Approx. 0.05 VA
Overload capability Thermal (effective)	100 x I_{nom} for 1 s 30 x I_{nom} for 10 s 4 x I_{nom} continuous 250 x I_{nom} (half cycle)
Dynamic (impulse current)	
Overload capability if equipped with sensitive earth-fault CT Thermal (effective)	300 A for 1 s 100 A for 10 s 15 A continuous 750 A (half cycle)
Dynamic (impulse current)	
Voltage transformer	
Rated voltage V_{nom}	100 V to 225 V
Power consumption at $V_{nom} = 100$ V	< 0.3 VA per phase
Overload capability in voltage path (phase-neutral voltage) Thermal (effective)	230 V continuous
Auxiliary voltage	
Rated auxiliary voltage V_{aux}	DC 24/48 V 60/125 V 110/250 V AC 115/230 V
Permissible tolerance	DC 19–58 V 48–150 V 88–300 V AC 92–138 V 184–265 V
Ripple voltage, peak-to-peak	≤ 12 %
Power consumption Quiescent Energized	Approx. 3–4 W Approx. 7–9 W
Backup time during loss/short circuit of auxiliary voltage	≥ 50 ms at $V \geq 110$ V DC ≥ 20 ms at $V \geq 24$ V DC ≥ 200 ms at 115 V/230 V AC
Binary inputs/indication inputs	
Type	7SJ621 7SJ622
Number	8 11
Voltage range	24–250 V DC
Pickup threshold modifiable by plug-in jumpers	
Pickup threshold	19 V DC 88 V DC
For rated control voltage	24/48/60/110/125 V 110/125/220/250 V DC
Response time/drop-out time	Approx. 3.5
Power consumption energized	1.8 mA (independent of operating voltage)

Binary outputs/command outputs		
Type	7SJ621	7SJ622
Command/indication relay	8	6
Contacts per command/indication relay	1 NO / form A (Two contacts changeable to NC/form B, via jumpers)	
Live status contact	1 NO / NC (jumper) / form A/B	
Switching capacity		
Make	1000 W / VA	
Break	30 W / VA / 40 W resistive / 25 W at L/R ≤ 50 ms	
Switching voltage	≤ 250 V DC	
Permissible current	5 A continuous, 30 A for 0.5 s making current, 2000 switching cycles	

Electrical tests

Specification

Standards	IEC 60255 ANSI C37.90, C37.90.1, C37.90.2, UL508
-----------	--

Insulation tests

Standards	IEC 60255-5; ANSI/IEEE C37.90.0
Voltage test (100 % test) all circuits except for auxiliary voltage and RS485/RS232 and time synchronization	2.5 kV (r.m.s. value), 50/60 Hz
Auxiliary voltage	3.5 kV DC
Communication ports and time synchronization	500 V AC
Impulse voltage test (type test) all circuits, except communication ports and time synchronization, class III	5 kV (peak value); 1.2/50 μs; 0.5 J 3 positive and 3 negative impulses at intervals of 5 s

EMC tests for interference immunity; type tests

Standards	IEC 60255-6; IEC 60255-22 (product standard) EN 50082-2 (generic specification) DIN 57435 Part 303
High-frequency test IEC 60255-22-1, class III and VDE 0435 Part 303, class III	2.5 kV (peak value); 1 MHz; $\tau = 15$ ms; 400 surges per s; test duration 2 s
Electrostatic discharge IEC 60255-22-2 class IV and EN 61000-4-2, class IV	8 kV contact discharge; 15 kV air gap discharge; both polarities; 150 pF; $R_i = 330 \Omega$
Irradiation with radio-frequency field, non-modulated IEC 60255-22-3 (Report) class III	10 V/m; 27 to 500 MHz
Irradiation with radio-frequency field, amplitude-modulated IEC 61000-4-3; class III	10 V/m, 80 to 1000 MHz; AM 80 %; 1 kHz
Irradiation with radio-frequency field, pulse-modulated IEC 61000-4-3/ENV 50204; class III	10 V/m, 900 MHz; repetition rate 200 Hz, on duration 50 %
Fast transient interference/burst IEC 60255-22-4 and IEC 61000-4-4, class IV	4 kV; 5/50 ns; 5 kHz; burst length = 15 ms; repetition rate 300 ms; both polarities; $R_i = 50 \Omega$; test duration 1 min

Technical data

High-energy surge voltages (Surge) IEC 61000-4-5; class III	
Auxiliary voltage	From circuit to circuit: 2 kV; 12 Ω; 9 μF across contacts: 1 kV; 2 Ω; 18 μF
Binary inputs/outputs	From circuit to circuit: 2 kV; 42 Ω; 0.5 μF across contacts: 1 kV; 42 Ω; 0.5 μF
Line-conducted HF, amplitude-modulated IEC 61000-4-6, class III	10 V; 150 kHz to 80 MHz; AM 80 %; 1 kHz
Power frequency magnetic field IEC 61000-4-8, class IV IEC 60255-6	30 A/m; 50 Hz, continuous 300 A/m; 50 Hz, 3 s 0.5 mT, 50 Hz
Oscillatory surge withstand capability ANSI/IEEE C37.90.1	2.5 to 3 kV (peak value), 1 to 1.5 MHz damped wave; 50 surges per s; duration 2 s, $R_1 = 150$ to 200Ω
Fast transient surge withstand capability ANSI/IEEE C37.90.1	4 to 5 kV; 10/150 ns; 50 surges per s both polarities; duration 2 s, $R_1 = 80 \Omega$
Radiated electromagnetic interference ANSI/IEEE C37.90.2	35 V/m; 25 to 1000 MHz; amplitude and pulse-modulated
Damped wave IEC 60694 / IEC 61000-4-12	2.5 kV (peak value, polarity alternating) 100 kHz, 1 MHz, 10 and 50 MHz, $R_1 = 200 \Omega$

EMC tests for interference emission; type tests

Standard	EN 50081-* (generic specification)
Conducted interferences only auxiliary voltage IEC/CISPR 22	150 kHz to 30 MHz Limit class B
Radio interference field strength IEC/CISPR 11	30 to 1000 MHz Limit class B
Units with a detached operator panel must be installed in a metal cubicle to maintain limit class B	

Mechanical stress tests

Vibration, shock stress and seismic vibration

During operation

Standards	IEC 60255-21 and IEC 60068-2
Vibration IEC 60255-21-1, class 2 IEC 60068-2-6	Sinusoidal 10 to 60 Hz; +/- 0.075 mm amplitude; 60 to 150 Hz; 1 g acceleration frequency sweep 1 octave/min 20 cycles in 3 perpendicular axes
Shock IEC 60255-21-2, class 1 IEC 60068-2-27	Semi-sinusoidal Acceleration 5 g, duration 11 ms; 3 shocks in both directions of 3 axes
Seismic vibration IEC 60255-21-3, class 1 IEC 60068-3-3	Sinusoidal 1 to 8 Hz: ± 3.5 mm amplitude (horizontal axis) 1 to 8 Hz: ± 1.5 mm amplitude (vertical axis) 8 to 35 Hz: 1 g acceleration (horizontal axis) 8 to 35 Hz: 0.5 g acceleration (vertical axis) Frequency sweep 1 octave/min 1 cycle in 3 perpendicular axes

During transportation

Standards	IEC 60255-21 and IEC 60068-2
Vibration IEC 60255-21-1, class 2 IEC 60068-2-6	Sinusoidal 5 to 8 Hz: ± 7.5 mm amplitude; 8 to 150 Hz; 2 g acceleration, frequency sweep 1 octave/min 20 cycles in 3 perpendicular axes
Shock IEC 60255-21-2, Class 1 IEC 60068-2-27	Semi-sinusoidal Acceleration 15 g, duration 11 ms 3 shocks in both directions of 3 axes
Continuous shock IEC 60255-21-2, class 1 IEC 60068-2-29	Semi-sinusoidal Acceleration 10 g, duration 16 ms 1000 shocks in both directions of 3 axes

Climatic stress tests

Temperatures

Type-tested acc. to IEC 60068-2-1 and -2, test Bd, for 16 h	-25 °C to +85 °C / -13 °F to +185 °F
Temporarily permissible operating temperature, tested for 96 h	-20 °C to +70 °C / -4 °F to +158 °F
Recommended permanent operating temperature acc. to IEC 60255-6 (Legibility of display may be impaired above +55 °C / +131 °F)	-5 °C to +55 °C / +25 °F to +131 °F
– Limiting temperature during permanent storage	-25 °C to +55 °C / -13 °F to +131 °F
– Limiting temperature during transport	-25 °C to +70 °C / -13 °F to +158 °F

Humidity

Permissible humidity It is recommended to arrange the units in such a way that they are not exposed to direct sunlight or pronounced temperature changes that could cause condensation.	Annual average 75 % relative humidity; on 56 days a year up to 95 % relative humidity; condensation not permissible!
--	--

Unit design

Housing	7XP20
Dimensions	See dimension drawings, part 16
Weight	
Surface-mounting housing	4.5 kg
Flush-mounting housing	4.0 kg
Degree of protection acc. to EN 60529	
Surface-mounting housing	IP 51
Flush-mounting housing	Front: IP 51, rear: IP 20;
Operator safety	IP 2x with cover

Technical data

Serial interfaces

Operating interface (front of unit)

Connection	Non-isolated, RS232; front panel, 9-pin subminiature connector
Transmission rate	min. 4800 baud, max. 38400 baud

Service/modem interface (rear of unit)

Isolated interface for data transfer	Port C: DIGSI 4/modem/RTD-box
Transmission rate	Setting as supplied 38400 baud min. 4800 baud, max. 38400 baud

RS232/RS485

Connection	9-pin subminiature connector, mounting location "C"
For flush-mounting housing/ surface-mounting housing with detached operator panel	
For surface-mounting housing with two-tier terminal at the top/bottom part	At the bottom part of the housing; shielded data cable
Distance RS232	15 m /49.2 ft
Distance RS485	Max. 1 km/3300 ft
Test voltage	500 V AC against earth

System interface (rear of unit)

IEC 60870-5-103 protocol

Isolated interface for data transfer to a control center	Port B
Transmission rate	Setting as supplied: 9600 baud, min. 9600 baud, max. 19200 baud

RS232/RS485

Connection	Mounting location "B"
For flush-mounting housing/ surface-mounting housing with detached operator panel	
For surface-mounting housing with two-tier terminal on the top/bottom part	At the bottom part of the housing; shielded data cable
Distance RS232	Max. 15 m/49 ft
Distance RS485	Max. 1 km/3300 ft
Test voltage	500 V AC against earth
Fiber optic	
Connection fiber-optic cable	Integrated ST connector for fi- ber-optic connection Mounting location "B"
For flush-mounting housing/ surface-mounting housing with detached operator panel	
For surface-mounting housing with two-tier terminal on the top/bottom part	At the bottom part of the housing
Optical wavelength	820 nm
Permissible path attenuation	Max. 8 dB, for glass fiber 62.5/125 µm
Distance	Max. 1.5 km/0.9 miles

IEC 61850 protocol

Isolated interface for data transfer: - to a control center - with DIGSI - between SIPROTEC 4 relays	Port B, 100 Base T acc. to IEEE802.3
Transmission rate	100 Mbit

Ethernet, electrical

Connection	Two RJ45 connectors mounting location "B"
For flush-mounting housing/ surface-mounting housing with detached operator panel	
Distance	Max. 20 m / 65.6 ft
Test voltage	500 V AC against earth

Ethernet, optical

Connection	Intergr. ST connector for FO connec- tion Mounting location "B"
For flush-mounting housing/ surface-mounting housing with detached operator panel	
Optical wavelength	1300 nm
Distance	1.5 km/0.9 miles

PROFIBUS-FMS/DP

Isolated interface for data transfer to a control center	Port B
Transmission rate	Up to 1.5 Mbaud

RS485

Connection	9-pin subminiature connector, mounting location "B"
For flush-mounting housing/ surface-mounting housing with detached operator panel	
For surface-mounting housing with two-tier terminal on the top/bottom part	At the bottom part of the housing; shielded data cable
Distance	1000 m/3300 ft ≤ 93.75 kbaud; 500 m/1500 ft ≤ 187.5 kbaud; 200 m/600 ft ≤ 1.5 Mbaud 100 m/300 ft ≤ 12 Mbaud
Test voltage	500 V AC against earth

Fiber optic

Connection fiber-optic cable	Integr. ST connector for FO connec- tion Mounting location "B"
For flush-mounting housing/ surface-mounting housing with detached operator panel	
For surface-mounting housing with two-tier terminal on the top/bottom part	At the bottom part of the housing Important: Please refer to footnotes ¹⁾ and ²⁾ on page 5/112
Optical wavelength	820 nm
Permissible path attenuation	Max. 8 dB, for glass fiber 62.5/125 µm
Distance	500 kB/s 1.6 km/0.99 miles 1500 kB/s 530 m/0.33 miles

MODBUS RTU, ASCII, DNP 3.0

Isolated interface for data transfer to a control center	Port B
Transmission rate	Up to 19200 baud

RS485

Connection	9-pin subminiature connector, mounting location "B"
For flush-mounting housing/ surface-mounting housing with detached operator panel	
For surface-mounting housing with two-tier terminal at the top/bottom part	At bottom part of the housing; shielded data cable
Test voltage	500 V AC against earth

Technical data

Fiber-optic

Connection fiber-optic cable	Integrated ST connector for fiber-optic connection Mounting location "B"
For flush-mounting housing/ surface-mounting housing with detached operator panel	
For surface-mounting housing with two-tier terminal at the top/bottom part	At the bottom part of the housing Important: Please refer to footnotes ¹⁾ and ²⁾ on page 5/112
Optical wavelength	820 nm
Permissible path attenuation	Max 8 dB. for glass fiber 62.5/125 μ m
Distance	Max. 1.5 km/0.9 miles

Time synchronization DCF77/IRIG-B signal (Format IRIG-B000)

Connection	9-pin subminiature connector (SUB-D) (terminal with surface-mounting housing)
Voltage levels	5 V, 12 V or 24 V (optional)

Functions

Definite-time overcurrent protection, directional/non-directional (ANSI 50, 50N, 67, 67N)

Operating mode non-directional phase protection (ANSI 50)	3-phase (standard) or 2-phase (L1 and L3)	
Setting ranges		
Pickup phase elements $I>, I>>$	0.5 to 175 A or ∞ ¹⁾ (in steps of 0.01 A)	
Pickup earth elements $I_E>, I_E>>$	0.25 to 175 A or ∞ ¹⁾ (in steps of 0.01 A)	
Delay times T	0 to 60 s or ∞ (in steps of 0.01 s)	
Dropout delay time T_{DO}	0 to 60 s (in steps of 0.01 s)	
Times		
Pickup times (without inrush restraint, with inrush restraint + 10 ms)	Non-directional	Directional
With twice the setting value	Approx. 30 ms	45 ms
With five times the setting value	Approx. 20 ms	40 ms
Dropout times	Approx. 40 ms	
Dropout ratio	Approx. 0.95 for $I/I_{nom} \geq 0.3$	
Tolerances		
Pickup	2 % of setting value or 50 mA ¹⁾	
Delay times T, T_{DO}	1 % or 10 ms	

Inverse-time overcurrent protection, directional/non-directional (ANSI 51, 51N, 67, 67N)

Operating mode non-directional phase protection (ANSI 51)	3-phase (standard) or 2-phase (L1 and L3)	
Setting ranges		
Pickup phase element I_P	0.5 to 20 A or ∞ ¹⁾ (in steps of 0.01 A)	
Pickup earth element I_{EP}	0.25 to 20 A or ∞ ¹⁾ (in steps of 0.01 A)	
Time multiplier T (IEC characteristics)	0.05 to 3.2 s or ∞ (in steps of 0.01 s)	
Time multiplier D (ANSI characteristics)	0.05 to 15 s or ∞ (in steps of 0.01 s)	

1) At $I_{nom} = 1$ A, all limits divided by 5.

Trip characteristics

IEC	Normal inverse, very inverse, extremely inverse, long inverse
ANSI	Inverse, short inverse, long inverse moderately inverse, very inverse, extremely inverse, definite inverse
User-defined characteristic	Defined by a maximum of 20 value pairs of current and time delay
Dropout setting	
Without disk emulation	Approx. $1.05 \cdot$ setting value I_P for $I_P/I_{nom} \geq 0.3$, corresponds to approx. $0.95 \cdot$ pickup threshold
With disk emulation	Approx. $0.90 \cdot$ setting value I_P
Tolerances	
Pickup/dropout thresholds I_P, I_{EP}	2 % of setting value or 50 mA ¹⁾
Pickup time for $2 \leq I/I_P \leq 20$	5 % of reference (calculated) value + 2 % current tolerance, respectively 30 ms
Dropout ratio for $0.05 \leq I/I_P \leq 0.9$	5 % of reference (calculated) value + 2 % current tolerance, respectively 30 ms

Direction detection

For phase faults

Polarization	With cross-polarized voltages; With voltage memory for measure- ment voltages that are too low
Forward range	$V_{ref,rot} \pm 86^\circ$
Rotation of reference voltage $V_{ref,rot}$	- 180° to 180° (in steps of 1°)
Direction sensitivity	For one and two-phase faults unlim- ited; For three-phase faults dynamically unlimited; Steady-state approx. 7 V phase-to-phase

For earth faults

Polarization	With zero-sequence quantities $3V_0, 3I_0$ or with negative-sequence quantities $3V_2, 3I_2$
Forward range	$V_{ref,rot} \pm 86^\circ$
Rotation of reference voltage $V_{ref,rot}$	- 180° to 180° (in steps of 1°)
Direction sensitivity	
Zero-sequence quantities $3V_0, 3I_0$	$V_E \approx 2.5$ V displacement voltage, measured; $3V_0 \approx 5$ V displacement voltage, calculated
Negative -sequence quantities $3V_2, 3I_2$	$3V_2 \approx 5$ V negative-sequence voltage; $3I_2 \approx 225$ mA negative-sequence cur- rent ¹⁾
Tolerances (phase angle error under reference conditions)	
For phase and earth faults	$\pm 3^\circ$ electrical

Inrush blocking

Influenced functions	Time-overcurrent elements, $I>, I_E>, I_P, I_{EP}$ (directional, non-directional)
Lower function limit	1.25 A ¹⁾
Upper function limit (setting range)	1.5 to 125 A ¹⁾ (in steps of 0.01 A)
Setting range I_{2f}/I	10 to 45 % (in steps of 1 %)
Crossblock (I_{L1}, I_{L2}, I_{L3})	ON/OFF

Technical data

Dynamic setting change

Controllable function	Directional and non-directional pickup, tripping time
Start criteria	Current criteria, CB position via aux. contacts, binary input, auto-reclosure ready
Time control	3 timers
Current criteria	Current threshold (reset on dropping below threshold; monitoring with timer)

(Sensitive) earth-fault detection (ANSI 64, 50Ns, 51Ns, 67Ns)**Displacement voltage starting for all types of earth fault (ANSI 64)**

Setting ranges	
Pickup threshold $V_E >$ (measured)	1.8 to 170 V (in steps of 0.1 V)
Pickup threshold $3V_0 >$ (calculated)	10 to 225 V (in steps of 0.1 V)
Delay time $T_{\text{Delay pickup}}$	0.04 to 320 s or ∞ (in steps of 0.01 s)
Additional trip delay T_{VDELAY}	0.1 to 40000 s or ∞ (in steps of 0.01 s)
Times	
Pickup time	Approx. 60 ms
Dropout ratio	0.95 or (pickup value -0.6 V)
Tolerances	
Pickup threshold V_E (measured)	3 % of setting value or 0.3 V
Pickup threshold $3V_0$ (calculated)	3 % of setting value or 3 V
Delay times	1 % of setting value or 10 ms

Phase detection for earth fault in an unearthed system

Measuring principle	Voltage measurement (phase-to-earth)
Setting ranges	
$V_{\text{ph min}}$ (earth-fault phase)	10 to 100 V (in steps of 1 V)
$V_{\text{ph max}}$ (unfaulted phases)	10 to 100 V (in steps of 1 V)
Measuring tolerance acc. to DIN 57435 part 303	3 % of setting value, or 1 V

Earth-fault pickup for all types of earth faults**Definite-time characteristic (ANSI 50Ns)**

Setting ranges	
Pickup threshold $I_{EE>}, I_{EE>>}$	
For sensitive input	0.001 to 1.5 A (in steps of 0.001 A)
For normal input	0.25 to 175 A ¹⁾ (in steps of 0.01 A)
Delay times T for $I_{EE>}, I_{EE>>}$	0 to 320 s or ∞ (in steps of 0.01 s)
Dropout delay time T_{DO}	0 to 60 s (in steps of 0.01 s)
Times	
Pickup times	Approx. 60 ms (non-directional) Approx. 80 ms (directional)
Dropout ratio	Approx. 0.95
Tolerances	
Pickup threshold $I_{EE>}, I_{EE>>}$	2 % of setting value or 1 mA
Delay times	1 % of setting value or 20 ms

1) For $I_{\text{nom}} = 1$ A, all limits divided by 5.**Earth-fault pickup for all types of earth faults****Inverse-time characteristic (ANSI 51Ns)**

User-defined characteristic	Defined by a maximum of 20 pairs of current and delay time values
Logarithmic inverse	$t = T_{I_{EEpmax}} - T_{I_{EEp}} \cdot \ln \frac{I}{I_{EEp}}$
Setting ranges	
Pickup threshold I_{EEp}	
For sensitive input	0.001 A to 1.4 A (in steps of 0.001 A)
For normal input	0.25 to 20 A ¹⁾ (in steps of 0.01 A)
User defined	
Time multiplier T	0.1 to 4 s or ∞ (in steps of 0.01 s)
Logarithmic inverse	
Time multiplier $T_{I_{EEp mul}}$	0.05 to 15 s or ∞ (in steps of 0.01 s)
Delay time $T_{I_{EEp}}$	0.1 to 4 s or ∞ (in steps of 0.01 s)
Min time delay $T_{I_{EEpmin}}$	0 to 32 s (in steps of 0.01 s)
Max. time delay $T_{I_{EEpmax}}$	0 to 32 s (in steps of 0.01 s)
Times	
Pickup times	Approx. 60 ms (non-directional) Approx 80 ms (directional)
Pickup threshold	Approx. $1.1 \cdot I_{EEp}$
Dropout ratio	Approx. $1.05 \cdot I_{EEp}$
Tolerances	
Pickup threshold I_{EEp}	2 % of setting value or 1 mA
Delay times in linear range	7 % of reference value for $2 \leq I/I_{EEp} \leq 20 + 2$ % current tolerance, or 70 ms

Direction detection for all types of earth-faults (ANSI 67Ns)

Direction measurement	I_E and V_E measured or $3I_0$ and $3V_0$ calculated
Measuring principle	Active/reactive power measurement
Setting ranges	
Measuring enable $I_{\text{Release direct}}$	
For sensitive input	0.001 to 1.2 A (in steps of 0.001 A)
For normal input	0.25 to 150 A ¹⁾ (in steps of 0.01 A)
Measuring method	$\cos \varphi$ and $\sin \varphi$
Direction phasor $\varphi_{\text{Correction}}$	-45 ° to +45 ° (in steps of 0.1 °)
Dropout delay $T_{\text{Reset delay}}$	1 to 60 s (in steps of 1 s)
Angle correction for cable CT	
Angle correction F1, F2	0 ° to 5 ° (in steps of 0.1 °)
Current value $I1, I2$	
For sensitive input	0.001 to 1.5 A (in steps of 0.001 A)
For normal input	0.25 to 175 A ¹⁾ (in steps of 0.01 A)
Tolerances	
Pickup measuring enable	2 % of the setting value or 1 mA
Angle tolerance	3 °

Note: Due to the high sensitivity the linear range of the measuring input IN with integrated sensitive input transformer is from 0.001 A to 1.6 A. For currents greater than 1.6 A, correct directionality can no longer be guaranteed.

Technical data

High-impedance restricted earth-fault protection (ANSI 87N) / single-phase overcurrent protection

Setting ranges	
Pickup thresholds $I_{>}, I_{>>}$	
For sensitive input	0.003 to 1.5 A or ∞ (in steps of 0.001 A)
For normal input	0.25 to 175 A ¹⁾ or ∞ (in steps of 0.01 A)
Delay times $T_{i>}, T_{i>>}$	0 to 60 s or ∞ (in steps of 0.01 s)
Times	
Pickup times	
Minimum	Approx. 20 ms
Typical	Approx. 30 ms
Dropout times	Approx. 30 ms
Dropout ratio	Approx. 0.95 for $I/I_{nom} \geq 0.5$
Tolerances	
Pickup thresholds	3 % of setting value or 1 % rated current at $I_{nom} = 1$ or 5 A; 5 % of setting value or 3 % rated current at $I_{nom} = 0.1$ A
Delay times	1 % of setting value or 10 ms

Intermittent earth-fault protection

Setting ranges	
Pickup threshold	
For I_E	$I_{IE>}$ 0.25 to 175 A ¹⁾ (in steps of 0.01 A)
For $3I_0$	$I_{IE>}$ 0.25 to 175 A ¹⁾ (in steps of 0.01 A)
For I_{EE}	$I_{IE>}$ 0.005 to 1.5 A (in steps of 0.001 A)
Pickup prolon- gation time	T_V 0 to 10 s (in steps of 0.01 s)
Earth-fault accu- mulation time	T_{sum} 0 to 100 s (in steps of 0.01 s)
Reset time for accumulation	T_{res} 1 to 600 s (in steps of 1 s)
Number of pickups for intermittent earth fault	2 to 10 (in steps of 1)
Times	
Pickup times	
Current = 1.25 · pickup value	Approx. 30 ms
Current $\geq 2 \cdot$ pickup value	Approx. 22 ms
Dropout time	Approx. 22 ms
Tolerances	
Pickup threshold $I_{IE>}$	3 % of setting value, or 50 mA ¹⁾
Times T_V, T_{sum}, T_{res}	1 % of setting value or 10 ms

1) For $I_{nom} = 1$ A, all limits divided by 5.**Thermal overload protection (ANSI 49)**

Setting ranges	
Factor k	0.1 to 4 (in steps of 0.01)
Time constant	1 to 999.9 min (in steps of 0.1 min)
Warning overtemperature $\Theta_{alarm}/\Theta_{trip}$	50 to 100 % with reference to the tripping overtemperature (in steps of 1 %)
Current warning stage I_{alarm}	0.5 to 20 A (in steps of 0.01 A)
Extension factor when stopped k_r factor	1 to 10 with reference to the time con- stant with the machine running (in steps of 0.1)
Rated overtemperature (for I_{nom})	40 to 200 °C (in steps of 1 °C)
Tripping characteristic For $(I/k \cdot I_{nom}) \leq 8$	$t = \tau_{th} \cdot \ln \frac{(I/k \cdot I_{nom})^2 - (I_{pre}/k \cdot I_{nom})^2}{(I/k \cdot I_{nom})^2 - 1}$
	t = Tripping time τ_{th} = Temperature rise time constant I = Load current I_{pre} = Preload current k = Setting factor acc. to VDE 0435 Part 3011 and IEC 60255-8 I_{nom} = Rated (nominal) current of the protection relay
Dropout ratios	
Θ/Θ_{Trip}	Drops out with Θ_{Alarm}
Θ/Θ_{Alarm}	Approx. 0.99
I/I_{Alarm}	Approx. 0.97
Tolerances	
With reference to $k \cdot I_{nom}$	Class 5 acc. to IEC 60255-8
With reference to tripping time	5 % +/- 2 s acc. to IEC 60255-8

Auto-reclosure (ANSI 79)

Number of reclosures	0 to 9 Shot 1 to 4 individually adjustable
Program for phase fault Start-up by	Time-overcurrent elements (dir., non-dir.), negative sequence, binary input
Program for earth fault Start-up by	Time-overcurrent elements (dir., non-dir.), sensitive earth-fault protection, binary input
Blocking of ARC	Pickup of protection functions, three-phase fault detected by a protec- tive element, binary input, last TRIP command after the reclosing cycle is complete (unsuccessful reclosing), TRIP command by the breaker failure protection (50BF), opening the CB without ARC initiation, external CLOSE command

Technical data

Auto-reclosure (cont'd)

Setting ranges	
Dead time (separate for phase and earth and individual for shots 1 to 4)	0.01 to 320 s (in steps of 0.01 s)
Blocking duration for manual- CLOSE detection	0.5 s to 320 s or 0 (in steps of 0.01 s)
Blocking duration after reclosure	0.5 s to 320 s (in steps of 0.01 s)
Blocking duration after dynamic blocking	0.01 to 320 s (in steps of 0.01 s)
Start-signal monitoring time	0.01 to 320 s or ∞ (in steps of 0.01 s)
Circuit-breaker supervision time	0.1 to 320 s (in steps of 0.01 s)
Max. delay of dead-time start	0 to 1800 s or ∞ (in steps of 0.1 s)
Maximum dead time extension	0.5 to 320 s or ∞ (in steps of 0.01 s)
Action time	0.01 to 320 s or ∞ (in steps of 0.01 s)

The delay times of the following protection function can be altered individually by the ARC for shots 1 to 4
(setting value $T = T$, non-delayed $T = 0$, blocking $T = \infty$):

$I_{>>}, I_{>}, I_p, I_{dir>>}, I_{dir>}, I_{pdir}$
 $I_{E>>}, I_{E>}, I_{Ep}, I_{Edir>>}, I_{Edir>}, I_{Edir}$

Additional functions	Lockout (final trip), delay of dead-time start via binary input (monitored), dead-time extension via binary input (monitored), co-ordination with other protection relays, circuit-breaker monitoring, evaluation of the CB contacts
----------------------	--

Breaker failure protection (ANSI 50 BF)

Setting ranges	
Pickup threshold CB $I_{>}$	0.2 to 5 A ¹⁾ (in steps of 0.01 A)
Delay time	0.06 to 60 s or ∞ (in steps of 0.01 s)
Times	
Pickup times with internal start start via control with external start	is contained in the delay time is contained in the delay time is contained in the delay time
Dropout times	Approx. 25 ms
Tolerances	
Pickup value	2 % of setting value (50 mA) ¹⁾
Delay time	1 % or 20 ms

1) At $I_{nom} = 1$ A, all limits divided by 5.

Negative-sequence current detection (ANSI 46)

Definite-time characteristic (ANSI 46-1 and 46-2)

Setting ranges	
Pickup current $I_{2>}, I_{2>>}$	0.5 to 15 A or ∞ (in steps of 0.01 A)
Delay times	0 to 60 s or ∞ (in steps of 0.01 s)
Dropout delay time T_{DO}	0 to 60 s (in steps of 0.01 s)
Functional limit	All phase currents ≤ 20 A ¹⁾
Times	
Pickup times	Approx. 35 ms
Dropout times	Approx. 35 ms
Dropout ratio	Approx. 0.95 for $I_2 / I_{nom} > 0.3$
Tolerances	
Pickup thresholds	3 % of the setting value or 50 mA ¹⁾
Delay times	1 % or 10 ms

Inverse-time characteristic (ANSI 46-TOC)

Setting ranges	
Pickup current	0.5 to 10 A ¹⁾ (in steps of 0.01 A)
Time multiplier T (IEC characteristics)	0.05 to 3.2 s or ∞ (in steps of 0.01 s)
Time multiplier D (ANSI characteristics)	0.5 to 15 s or ∞ (in steps of 0.01 s)
Functional limit	All phase currents ≤ 20 A ¹⁾
Trip characteristics	
IEC	Normal inverse, very inverse, extremely inverse
ANSI	Inverse, moderately inverse, very in- verse, extremely inverse
Pickup threshold	Approx. $1.1 \cdot I_{2p}$ setting value
Dropout	
IEC and ANSI (without disk emulation)	Approx. $1.05 \cdot I_{2p}$ setting value, which is approx. $0.95 \cdot$ pickup threshold
ANSI with disk emulation	Approx. $0.90 \cdot I_{2p}$ setting value
Tolerances	
Pickup threshold	3 % of the setting value or 50 mA ¹⁾
Time for $2 \leq M \leq 20$	5 % of setpoint (calculated) +2 % current tolerance, at least 30 ms

Starting time monitoring for motors (ANSI 48)

Setting ranges	
Motor starting current $I_{STARTUP}$	2.5 to 80 A ¹⁾ (in steps of 0.01)
Pickup threshold $I_{MOTOR START}$	2 to 50 A ¹⁾ (in steps of 0.01)
Permissible starting time $T_{STARTUP}$	1 to 180 s (in steps of 0.1 s)
Permissible blocked rotor time $T_{LOCKED-ROTOR}$	0.5 to 120 s or ∞ (in steps of 0.1 s)
Tripping time characteristic	
For $I > I_{MOTOR START}$	$t = \left(\frac{I_{STARTUP}}{I} \right)^2 \cdot T_{STARTUP}$
	$I_{STARTUP}$ = Rated motor starting current
	I = Actual current flowing
	$T_{STARTUP}$ = Tripping time for rated motor starting current
	t = Tripping time in seconds
Dropout ratio $I_{MOTOR START}$	Approx. 0.95
Tolerances	
Pickup threshold	2 % of setting value or 50 mA ¹⁾
Delay time	5 % or 30 ms

Technical data

Restart inhibit for motors (ANSI 66)

Setting ranges

Motor starting current relative to rated motor current $I_{MOTOR\ START}/I_{Motor\ Nom}$	1.1 to 10 (in steps of 0.1)
Rated motor current $I_{Motor\ Nom}$	1 to 6 A ¹⁾ (in steps of 0.01 A)
Max. permissible starting time $T_{Start\ Max}$	3 to 320 s (in steps of 1 s)
Equilibrium time T_{Equal}	0 min to 320 min (in steps of 0.1 min)
Minimum inhibit time $T_{MIN.\ INHIBIT\ TIME}$	0.2 min to 120 min (in steps of 0.1 min)
Max. permissible number of warm starts	1 to 4 (in steps of 1)
Difference between cold and warm starts	1 to 2 (in steps of 1)
Extension k-factor for cooling simulations of rotor at zero speed $k_{\tau\ at\ STOP}$	0.2 to 100 (in steps of 0.1)
Extension factor for cooling time constant with motor running $k_{\tau\ RUNNING}$	0.2 to 100 (in steps of 0.1)

Restarting limit

$$\Theta_{restart} = \Theta_{rot\ max\ perm} \cdot \frac{n_c - 1}{n_c}$$

$\Theta_{restart}$ = Temperature limit below which restarting is possible
 $\Theta_{rot\ max\ perm}$ = Maximum permissible rotor overtemperature (= 100 % in operational measured value $\Theta_{rot}/\Theta_{rot\ trip}$)
 n_c = Number of permissible start-ups from cold state

Undercurrent monitoring (ANSI 37)

Signal from the operational measured values	Predefined with programmable logic
---	------------------------------------

Temperature monitoring box (ANSI 38)

Temperature detectors	
Connectable boxes	1 or 2
Number of temperature detectors per box	Max. 6
Type of measuring	Pt 100 Ω or Ni 100 Ω or Ni 120 Ω
Mounting identification	"Oil" or "Environment" or "Stator" or "Bearing" or "Other"
Thresholds for indications	
For each measuring detector	
Stage 1	-50 °C to 250 °C (in steps of 1 °C) -58 °F to 482 °F (in steps of 1 °F) or ∞ (no indication)
Stage 2	-50 °C to 250 °C (in steps of 1 °C) -58 °F to 482 °F (in steps of 1 °F) or ∞ (no indication)

1) At $I_{nom} = 1$ A, all limits divided by 5.**Undervoltage protection (ANSI 27)**

Operating modes/measuring quantities

3-phase	Positive-sequence component or smallest of the phase-to-phase voltages
1-phase	Single-phase phase-earth or phase-phase voltage

Setting ranges

Pickup thresholds $V<$, $V<<$	
3-phase, phase-earth connection	10 to 210 V (in steps of 1 V)
3-phase, phase-phase connection	10 to 120 V (in steps of 1 V)
1-phase connection	10 to 120 V (in steps of 1 V)
Dropout ratio r	1.01 to 3 (in steps of 0.01)
Delay times T	0 to 100 s or ∞ (in steps of 0.01 s)
Current Criteria "Bkr Closed I_{MIN} "	0.2 to 5 A ¹⁾ (in steps of 0.01 A)

Dropout threshold $r \cdot V<(<)$

Max. 130 V for phase-phase voltages
Max. 225 V phase-earth voltages

Times

Pickup times $V<$, $V<<$, $V_1<$, $V_1<<$	Approx. 50 ms
Dropout times	As pickup times

Tolerances

Pickup thresholds	3 % of setting value or 1 V
Times	1 % of setting value or 10 ms

Overvoltage protection (ANSI 59)

Operating modes/measuring quantities

3-phase	Negative-sequence component or largest of the phase-to-phase voltages
1-phase	Single-phase phase-earth or phase-phase voltage

Setting ranges

Pickup thresholds $V>$, $V>>$	
3-phase, phase-earth connection, largest phase-phase voltage	40 to 260 V (in steps of 1 V)
3-phase, phase-phase connection, largest phase-phase voltage	40 to 150 V (in steps of 1 V)
3-phase, negative-sequence voltage	2 to 150 V (in steps of 1 V)
1-phase connection	40 to 150 V (in steps of 1 V)
Dropout ratio r	0.9 to 0.99 (in steps of 0.01)
Delay times T	0 to 100 s or ∞ (in steps of 0.01 s)

Times

Pickup times $V>$, $V>>$	Approx. 50 ms
Pickup times $V_2>$, $V_2>>$	Approx. 60 ms
Dropout times	As pickup times

Tolerances

Pickup thresholds	3 % of setting value or 1 V
Times	1 % of setting value or 10 ms

Technical data

Frequency protection (ANSI 81)

Number of frequency elements	4
Setting ranges	
Pickup thresholds for $f_{nom} = 50$ Hz	45.5 to 54.5 Hz (in steps of 0.01 Hz)
Pickup thresholds for $f_{nom} = 60$ Hz	55.5 to 64.5 Hz (in steps of 0.01 Hz)
Delay times	0 to 100 s or ∞ (in steps of 0.01 s)
Undervoltage blocking, with positive-sequence voltage V_1	10 to 150 V (in steps of 1 V)
Times	
Pickup times	Approx. 150 ms
Dropout times	Approx. 150 ms
Dropout	
Δf = pickup value - dropout value	Approx. 20 mHz
Ratio undervoltage blocking	Approx. 1.05
Tolerances	
Pickup thresholds	
Frequency	10 mHz
Undervoltage blocking	3 % of setting value or 1 V
Delay times	3 % of the setting value or 10 ms

Fault locator (ANSI 21FL)

Output of the fault distance	In Ω secondary, in km / mile of line length
Starting signal	Trip command, dropout of a protection element, via binary input
Setting ranges	
Reactance (secondary)	0.001 to 1.9 Ω/km^1 (in steps of 0.0001) 0.001 to 3 Ω/mile^1 (in steps of 0.0001)
Tolerances	
Measurement tolerance acc. to VDE 0435, Part 303 for sinusoidal measurement quantities	2.5 % fault location, or 0.025 Ω (without intermediate infeed) for $30^\circ \leq \varphi_K \leq 90^\circ$ and $V_K/V_{nom} \geq 0.1$ and $I_K/I_{nom} \geq 1$

1) At $I_{nom} = 1$ A, all limits multiplied with 5.

2) At rated frequency.

Additional functions

Operational measured values

Currents I_{L1}, I_{L2}, I_{L3} Positive-sequence component I_1 Negative-sequence component I_2 I_E or $3I_0$	In A (kA) primary, in A secondary or in % I_{nom}
Range Tolerance ²⁾	10 to 200 % I_{nom} 1 % of measured value or 0.5 % I_{nom}
Phase-to-earth voltages $V_{L1-E}, V_{L2-E}, V_{L3-E}$ Phase-to-phase voltages $V_{L1-L2}, V_{L2-L3}, V_{L3-L1}, V_E$ or V_0 Positive-sequence component V_1 Negative-sequence component V_2	In kV primary, in V secondary or in % V_{nom}
Range Tolerance ²⁾	10 to 120 % V_{nom} 1 % of measured value or 0.5 % of V_{nom}
S, apparent power	In kVAR (MVAR or GVAR) primary and in % of S_{nom}
Range Tolerance ²⁾	0 to 120 % S_{nom} 1 % of S_{nom} for V/V_{nom} and $I/I_{nom} = 50$ to 120 %
P, active Power	With sign, total and phase-segregated in kW (MW or GW) primary and in % S_{nom}
Range Tolerance ²⁾	0 to 120 % S_{nom} 2 % of S_{nom} for V/V_{nom} and $I/I_{nom} = 50$ to 120 % and $ \cos \varphi = 0.707$ to 1 with $S_{nom} = \sqrt{3} \cdot V_{nom} \cdot I_{nom}$
Q, reactive power	With sign, total and phase-segregated in kVAR (MVAR or GVAR) primary and in % S_{nom}
Range Tolerance ²⁾	0 to 120 % S_{nom} 2 % of S_{nom} for V/V_{nom} and $I/I_{nom} = 50$ to 120 % and $ \sin \varphi = 0.707$ to 1 with $S_{nom} = \sqrt{3} \cdot V_{nom} \cdot I_{nom}$
$\cos \varphi$, power factor (p.f.)	Total and phase segregated
Range Tolerance ²⁾	- 1 to + 1 3 % for $ \cos \varphi \geq 0.707$
Frequency f	In Hz
Range Tolerance ²⁾	$f_{nom} \pm 5$ Hz 20 mHz
Temperature overload protection Θ/Θ_{Trip}	In %
Range Tolerance ²⁾	0 to 400 % 5 % class accuracy per IEC 60255-8
Temperature restart inhibit $\Theta_L/\Theta_{L Trip}$	In %
Range Tolerance ²⁾	0 to 400 % 5 % class accuracy per IEC 60255-8
Restart threshold $\Theta_{Restart}/\Theta_{L Trip}$	In %
Reclose time $T_{Reclose}$	In min
Currents of sensitive ground fault detection (total, real, and reactive current) $I_{EE}, I_{EE real}, I_{EE reactive}$	In A (kA) primary and in mA secondary
Range Tolerance ²⁾	0 mA to 1600 mA 2 % of measured value or 1 mA
RTD-box	See section "Temperature monitoring box"

Technical data

Long-term averages	
Time window	5, 15, 30 or 60 minutes
Frequency of updates	Adjustable
Long-term averages of currents of real power of reactive power of apparent power	$I_{L1dmd}, I_{L2dmd}, I_{L3dmd}, I_{Idmd}$ in A (kA) P_{dmd} in W (kW, MW) Q_{dmd} in VAr (kVAr, MVar) S_{dmd} in VAr (kVAr, MVar)
Max. / Min. report	
Report of measured values	With date and time
Reset, automatic	Time of day adjustable (in minutes, 0 to 1439 min) Time frame and starting time adjustable (in days, 1 to 365 days, and ∞)
Reset, manual	Using binary input, using keypad, via communication
Min./Max. values for current	$I_{L1}, I_{L2}, I_{L3}, I_1$ (positive-sequence component)
Min./Max. values for voltages	$V_{L1-E}, V_{L2-E}, V_{L3-E}, V_1$ (positive-sequence component) $V_{L1-L2}, V_{L2-L3}, V_{L3-L1}$
Min./Max. values for power	$S, P, Q, \cos \varphi$, frequency
Min./Max. values for overload protection	Θ/Θ_{Trip}
Min./Max. values for mean values	$I_{L1dmd}, I_{L2dmd}, I_{L3dmd}, I_1$ (positive-sequence component); $S_{dmd}, P_{dmd}, Q_{dmd}$
Local measured values monitoring	
Current asymmetry	$I_{max}/I_{min} >$ balance factor, for $I > I_{balance\ limit}$
Voltage asymmetry	$V_{max}/V_{min} >$ balance factor, for $V > V_{lim}$
Current sum	$ i_{L1} + i_{L2} + i_{L3} + k_{IE} \cdot i_E >$ limit value, with $k_{IE} = \frac{I_{earth} CT PRIM / I_{earth} CT SEC}{CT PRIM / CT SEC}$
Current phase sequence	Clockwise (ABC) / counter-clockwise (ACB)
Voltage phase sequence	Clockwise (ABC) / counter-clockwise (ACB)
Limit value monitoring	Predefined limit values, user-defined expansions via CFC
Fault recording	
Recording of indications of the last 8 power system faults	
Recording of indications of the last 3 power system ground faults	

Time stamping	
Resolution for event log (operational annunciations)	1 ms
Resolution for trip log (fault annunciations)	1 ms
Maximum time deviation (internal clock)	0.01 %
Battery	Lithium battery 3 V/1 Ah, type CR 1/2 AA, message "Battery Fault" for insufficient battery charge
Oscillographic fault recording	
Maximum 8 fault records saved, memory maintained by buffer battery in case of loss of power supply	
Recording time	Total 5 s Pre-trigger and post-fault recording and memory time adjustable
Sampling rate for 50 Hz	1 sample/1.25 ms (16 sam/cyc)
Sampling rate for 60 Hz	1 sample/1.04 ms (16 sam/cyc)
Energy/power	
Meter values for power W_p, W_q (real and reactive power demand)	in kWh (MWh or GWh) and kVARh (MVARh or GVARh)
Tolerance ¹⁾	$\leq 5\%$ for $I > 0.5 I_{nom}, V > 0.5 V_{nom}$ and $ \cos \varphi (p.f.) \geq 0.707$
Statistics	
Saved number of trips	Up to 9 digits
Number of automatic reclosing commands (segregated according to 1 st and $\geq 2^{nd}$ cycle)	Up to 9 digits
Circuit-breaker wear	
Methods	<ul style="list-style-type: none"> ΣI^x with $x = 1 \dots 3$ 2-point method (remaining service life)
Operation	Phase-selective accumulation of measured values on TRIP command, up to 8 digits, phase-selective limit values, monitoring indication
Operating hours counter	
Display range	Up to 7 digits
Criterion	Overshoot of an adjustable current threshold (BkrClosed I_{MIN})
Trip circuit monitoring	
With one or two binary inputs	
Commissioning aids	
Phase rotation field check, operational measured values, circuit-breaker / switching device test, creation of a test measurement report	
1) At rated frequency.	

Technical data

Clock

Time synchronization	DCF77/IRIG-B signal (telegram format IRIG-B000), binary input, communication
----------------------	--

Setting group switchover of the function parameters

Number of available setting groups	4 (parameter group A, B, C and D)
Switchover performed	Via keypad, DIGSI, system (SCADA) interface or binary input

Control

Number of switching units	Depends on the binary inputs and outputs
Interlocking	Programmable
Circuit-breaker signals	Feedback, close, open, intermediate position
Control commands	Single command / double command 1, 1 plus 1 common or 2 trip contacts
Programmable controller	CFC logic, graphic input tool
Local control	Control via menu, assignment of a function key
Remote control	Via communication interfaces, using a substation automation and control system (e.g. SICAM), DIGSI 4 (e.g. via modem)

CE conformity

This product is in conformity with the Directives of the European Communities on the harmonization of the laws of the Member States relating to electromagnetic compatibility (EMC Council Directive 89/336/EEC) and electrical equipment designed for use within certain voltage limits (Council Directive 73/23/EEC).

This unit conforms to the international standard IEC 60255, and the German standard DIN 57435/Part 303 (corresponding to VDE 0435/Part 303). Further applicable standards: ANSI/IEEE C37.90.0 and C37.90.1.

The unit conforms to the international standard IEC 60255, and the German standard DIN 57435/Part 303 (corresponding to VDE 0435/Part 303).

This conformity is the result of a test that was performed by Siemens AG in accordance with Article 10 of the Council Directive complying with the generic standards EN 50081-2 and EN 50082-2 for the EMC Directive and standard EN 60255-6 for the "low-voltage Directive".

Selection and ordering data

Description	Order No.
7SJ62 multifunction protection relay	7SJ62 □ □ - □ □ □ □ □ □ - □ □ □ □ □ □
<i>Housing, binary inputs (BI) and outputs (BO)</i>	
Housing 1/3 19"; 8 BI, 8 BO, 1 live status contact	1
Housing 1/3 19"; 11 BI, 6 BO, 1 live status contact	2
<i>Measuring inputs (3 x V, 4 x I)</i>	
$I_{ph} = 1 A^{1)}$, $I_e = 1 A^{1)}$ (min. = 0.05 A)	
Position 15 only with A, C, E, G	1
$I_{ph} = 1 A^{1)}$, $I_e =$ sensitive (min. = 0.001 A)	
Position 15 only with B, D, F, H	2
$I_{ph} = 5 A^{1)}$, $I_e = 5 A^{1)}$ (min. = 0.25 A)	
Position 15 only with A, C, E, G	5
$I_{ph} = 5 A^{1)}$, $I_e =$ sensitive (min. = 0.001 A)	
Position 15 only with B, D, F, H	6
$I_{ph} = 5 A^{1)}$, $I_e = 1 A^{1)}$ (min. = 0.05 A)	
Position 15 only with A, C, E, G	7
<i>Rated auxiliary voltage (power supply, indication voltage)</i>	
24 to 48 V DC, threshold binary input 19 DC ³⁾	2
60 to 125 V DC ²⁾ , threshold binary input 19 DC ³⁾	4
110 to 250 V DC ²⁾ , 115 to 230 V ⁴⁾ AC, threshold binary input 88 V DC ³⁾	5
<i>Unit version</i>	
For panel surface mounting, two-tier terminal top/bottom	B
For panel flush mounting, plug-in terminal, (2/3 pin connector)	D
For panel flush mounting, screw-type terminal (direct connection/ring-type cable lugs)	E
<i>Region-specific default settings/function versions and language settings</i>	
Region DE, 50 Hz, IEC, language: German, selectable	A
Region World, 50/60 Hz, IEC/ANSI, language: English (GB), selectable	B
Region US, 60 Hz, ANSI, language: English (US), selectable	C
Region FR, 50/60 Hz, IEC/ANSI, language: French, selectable	D
Region World, 50/60 Hz, IEC/ANSI, language: Spanish, selectable	E
<i>System interface (Port B): Refer to page 5/112</i>	
No system interface	0
Protocols see page 5/112	
<i>Service interface (Port C)</i>	
No interface at rear side	0
DIGSI 4/modem, electrical RS232	1
DIGSI 4/modem/RTD-box ⁵⁾ , electrical RS485	2
DIGSI 4/modem/RTD-box ⁵⁾⁶⁾ , optical 820 nm wave length, ST connector	3
<i>Measuring/fault recording</i>	
Fault recording	1
Slave pointer, mean values, min/max values, fault recording	3

see
next
page

5

- Rated current can be selected by means of jumpers.
- Transition between the two auxiliary voltage ranges can be selected by means of jumpers.
- The binary input thresholds can be selected per binary input by means of jumpers.
- 230 V AC, starting from device version .../EE.
- Temperature monitoring box
7XV5662-□AD10, refer to "Accessories".
- When using the temperature monitoring box at an optical interface, the additional RS485 fiber-optic converter 7XV5650-0□A00 is required.

Selection and ordering data

Description		Order No.	
7SJ62 multifunction protection relay		7SJ62□□ - □□□□□□ - □□□□□	
Designation	ANSI No.	Description	
Basic version			
	50/51	Control	
		Time-overcurrent protection	
		$I>$, $I>>$, I_p , reverse interlocking	
	50N/51N	Earth-fault protection	
		$I_E>$, $I_E>>$, I_{Ep}	
	50N/51N	Insensitive earth-fault protection via IEE function: $I_{EE>}$, $I_{EE>>}$, $I_{EEp}^{1)}$	
	49	Overload protection (with 2 time constants)	
	46	Phase balance current protection (negative-sequence protection)	
	37	Undercurrent monitoring	
	47	Phase sequence	
	59N/64	Displacement voltage	
	50BF	Breaker failure protection	
	74TC	Trip circuit supervision	
		4 setting groups, cold-load pickup	
		Inrush blocking	
	86	Lockout	
■	V, f	27/59 Under-/overvoltage	F E
		81 O/U Under-/overfrequency	
■	IEF V, f	27/59 Under-/overvoltage	P E
		81 O/U Under-/overfrequency	
	Dir	67/67N Direction determination for overcurrent, phases and earth	F C
■	Dir V, f	67/67N Direction determination for overcurrent, phases and earth	F G
		27/59 Under-/overvoltage	
		81O/U Under-/overfrequency	
■	Dir IEF	67/67N Direction determination for overcurrent, phases and earth	P C
		Intermittent earth fault	
Directional earth-fault detection	Dir	67/67N Direction determination for overcurrent, phases and earth	F D ²⁾
		67Ns Directional sensitive earth-fault detection	
		87N High-impedance restricted earth fault	
■	Dir IEF	67/67N Direction determination for overcurrent, phases and earth	P D ²⁾
		67Ns Directional sensitive earth-fault detection	
		87N High-impedance restricted earth fault	
		Intermittent earth fault	
Directional earth-fault detection		67Ns Directional sensitive earth-fault detection,	F B ²⁾
		87N High-impedance restricted earth fault	
■	Motor V, f	67Ns Directional sensitive earth-fault detection,	H F ²⁾
		87N High-impedance restricted earth fault	
		48/14 Starting time supervision, locked rotor	
		66/86 Restart inhibit	
		27/59 Under-/overvoltage	
		81O/U Under-/overfrequency	
Directional earth-fault detection	Motor Dir V, f	67/67N Direction determination for overcurrent, phases and earth	H H ²⁾
		67Ns Directional sensitive earth-fault detection	
		87N High-impedance restricted earth fault	
		48/14 Starting time supervision, locked rotor	
		66/86 Restart inhibit	
		27/59 Under-/overvoltage	
		81O/U Under-/overfrequency	

■ Basic version included
 V, f = Voltage, frequency protection
 Dir = Directional overcurrent protection
 IEF = Intermittent earth fault

1) Only with insensitive earth-current transformer when position 7 = 1, 5, 7.

2) For isolated/compensated networks only with sensitive earth-current transformer when position 7 = 2, 6.

Continued on next page

Selection and ordering data

Description			Order No.	Order code	
<i>7SJ62 multifunction protection relay</i>			<i>7SJ62</i> □□ - □□□□□ - □□□□□□□□		
Designation	ANSI No.	Description			
Basic version					
		Control			
	50/51	Time-overcurrent protection $I>$, $I>>$, I_p , reverse interlocking			
	50N/51N	Earth-fault protection $I_E>$, $I_E>>$, I_{Ep}			
	50N/51N	Insensitive earth-fault protection via IEE function: $I_{EE>}$, $I_{EE>>}$, I_{EEp} ¹⁾			
	49	Overload protection (with 2 time constants)			
	46	Phase balance current protection (negative-sequence protection)			
	37	Undercurrent monitoring			
	47	Phase sequence			
	59N/64	Displacement voltage			
	50BF	Breaker failure protection			
	74TC	Trip circuit supervision 4 setting groups, cold-load pickup Inrush blocking			
	86	Lockout			
Directional earth-fault detection	Motor Dir	V, f	67/67N	Direction determination for overcurrent, phases and earth	
			67Ns	Directional sensitive earth-fault detection	
			87N	High-impedance restricted earth fault	
			48/14	Starting time supervision, locked rotor	
			66/86	Restart inhibit	
			27/59	Under-/overvoltage	
	81O/U	Under-/overfrequency		R H ²⁾	
■	Motor Dir	V, f	67/67N	Direction determination for overcurrent, phases and earth	
			48/14	Starting time supervision, locked rotor	
			66/86	Reclosing lockout	
			27/59	Under/overvoltage	
			81 O/U	Under/overfrequency	
ARC, fault locator					
		Without		0	
		79 With auto-reclosure		1	
		21 FL With fault locator		2	
		79, 21 FL With auto-reclosure, with fault locator		3	
ATEX100 Certification					
For protection of explosion-protected motors (increased-safety type of protection "e")				Z X 9 9	

■ Basic version included

V, f = Voltage, frequency protection
Dir = Directional overcurrent protection
IEF = Intermittent earth fault

- 1) Only with insensitive earth-current transformer when position 7 = 1, 5, 7.
- 2) For isolated/compensated networks only with sensitive earth-current transformer when position 7 = 2, 6.

Order number for system port B

Description	Order No.	Order code
<i>7SJ62 multifunction protection relay</i>		
<i>7SJ62□□ - □□□□□ - □□□□ - □□□</i>		
System interface (on rear of unit, Port B)		
No system interface	0	
IEC 60870-5-103 protocol, RS232	1	
IEC 60870-5-103 protocol, RS485	2	
IEC 60870-5-103 protocol, 820 nm fiber, ST connector	3	
PROFIBUS-FMS Slave, RS485	4	
PROFIBUS-FMS Slave, 820 nm wavelength, single ring, ST connector ¹⁾	5	
PROFIBUS-FMS Slave, 820 nm wavelength, double ring, ST connector ¹⁾	6	
PROFIBUS-DP Slave, RS485	9	L O A
PROFIBUS-DP Slave, 820 nm wavelength, double ring, ST connector ¹⁾	9	L O B
MODBUS, RS485	9	L O D
MODBUS, 820 nm wavelength, ST connector ²⁾	9	L O E
DNP 3.0, RS485	9	L O G
DNP 3.0, 820 nm wavelength, ST connector ²⁾	9	L O H
IEC 61850, 100 Mbit Ethernet, electrical, double, RJ45 connector (EN 100)	9	L O R
IEC 61850, 100 Mbit Ethernet, optical, double, ST connector (EN 100) ²⁾	9	L O S

- 1) Not with position 9 = "B"; if 9 = "B", please order 7SJ6 unit with RS485 port and separate fiber-optic converters.
 For single ring, please order converter 6GK1502-2CB10, not available with position 9 = "B".
 For double ring, please order converter 6GK1502-3CB10, not available with position 9 = "B".
 The converter requires a 24 V AC power supply (e.g. power supply 7XV5810-0BA00)
- 2) Not available with position 9 = "B"

5

Sample order

Position	Order No. + Order code
	<i>7SJ6225-5EC91-3FC1+LOG</i>
6 I/O's: 11 BI/6 BO, 1 live status contact	2
7 Current transformer: 5 A	5
8 Power supply: 110 to 250 V DC, 115 V AC to 230 V AC	5
9 Unit version: Flush-mounting housing, screw-type terminals	E
10 Region: US, English language (US); 60 Hz, ANSI	C
11 Communication: System interface: DNP 3.0, RS485	9 LOG
12 Communication: DIGSI 4, electric RS232	1
13 Measuring/fault recording: Extended measuring and fault records	3
14/15 Protection function package: Basic version plus directional TOC	FC
16 With auto-reclosure	1

Accessories

Description	Order No.
DIGSI 4	
Software for configuration and operation of Siemens protection units running under MS Windows 2000/XP Professional Edition	
Basis	Full version with license for 10 computers, on CD-ROM (authorization by serial number) 7XS5400-0AA00
Professional	DIGSI 4 Basis and additionally SIGRA (fault record analysis), CFC Editor (logic editor), Display Editor (editor for default and control displays) and DIGSI 4 Remote (remote operation) 7XS5402-0AA00
Professional + IEC 61850	Complete version: DIGSI 4 Basis and additionally SIGRA (fault record analysis), CFC Editor (logic editor), Display Editor (editor for default and control displays) and DIGSI 4 Remote (remote operation) + IEC 61850 system configurator 7XS5403-0AA00
IEC 61850 System configurator	
Software for configuration of stations with IEC 61850 communication under DIGSI, running under MS Windows 2000 or XP Professional Edition	
Optional package for DIGSI 4 Basis or Professional	
License for 10 PCs. Authorization by serial number. On CD-ROM 7XS5460-0AA00	
SIGRA 4	
Software for graphic visualization, analysis and evaluation of fault records. Can also be used for fault records of devices of other manufacturers (Comtrade format). Running under MS Windows 2000 or XP Professional Edition. (generally contained in DIGSI Professional, but can be ordered additionally)	
Authorization by serial number. On CD-ROM. 7XS5410-0AA00	
Temperature monitoring box	
24 to 60 V AC/DC	7XV5662-2AD10
90 to 240 V AC/DC	7XV5662-5AD10
Varistor/Voltage arrester	
Voltage arrester for high-impedance REF protection	
125 Vrms; 600 A; 1S/S 256	C53207-A401-D76-1
240 Vrms; 600 A; 1S/S 1088	C53207-A401-D77-1
Connecting cable	
Cable between PC/notebook (9-pin con.) and protection unit (9-pin connector) (contained in DIGSI 4, but can be ordered additionally) 7XV5100-4	
Cable between temperature monitoring box and SIPROTEC 4 unit	
- length 5 m /16.4 ft	7XV5103-7AA05
- length 25 m /82 ft	7XV5103-7AA25
- length 50 m /164 ft	7XV5103-7AA50
Manual for 7SJ62/63/64,	
English	C53000-G1140-C147-6
French	C53000-G1177-C147-2
Spanish	C53000-G1178-C147-2
Catalog SIP 3.1 Spanish	E50001-K4403-A111-A1-7800

Accessories



LSP2289-afp.eps

Mounting rail



LSP2090-afp.eps

2-pin
connector

LSP2091-afp.eps

3-pin
connector

LSP2093-afp.eps

Short-circuit links
for current termi-
nals

LSP2092-afp.eps

Short-circuit links
for other terminals

Description	Order No.	Size of package	Supplier
Terminal safety cover			
Voltage/current terminal 18-pole/12-pole	C73334-A1-C31-1	1	Siemens
Voltage/current terminal 12-pole/8-pole	C73334-A1-C32-1	1	Siemens
Connector 2-pin	C73334-A1-C35-1	1	Siemens
Connector 3-pin	C73334-A1-C36-1	1	Siemens
Crimp connector CI2 0.5 to 1 mm ²	0-827039-1	4000 taped on reel	AMP ¹⁾
Crimp connector CI2 0.5 to 1 mm ²	0-827396-1	1	AMP ¹⁾
Crimp connector: Type III+ 0.75 to 1.5 mm ²	0-163084-2	1	AMP ¹⁾
Crimp connector: Type III+ 0.75 to 1.5 mm ²	0-163083-7	4000 taped on reel	AMP ¹⁾
Crimping tool for Type III+ and matching female	0-539635-1	1	AMP ¹⁾
	0-539668-2	1	AMP ¹⁾
Crimping tool for CI2 and matching female	0-734372-1	1	AMP ¹⁾
	1-734387-1	1	AMP ¹⁾
Short-circuit links for current terminals	C73334-A1-C33-1	1	Siemens
Short-circuit links for other terminals	C73334-A1-C34-1	1	Siemens
Mounting rail for 19" rack	C73165-A63-D200-1	1	Siemens

1) Your local Siemens representative
can inform you on local suppliers.

Connection diagram

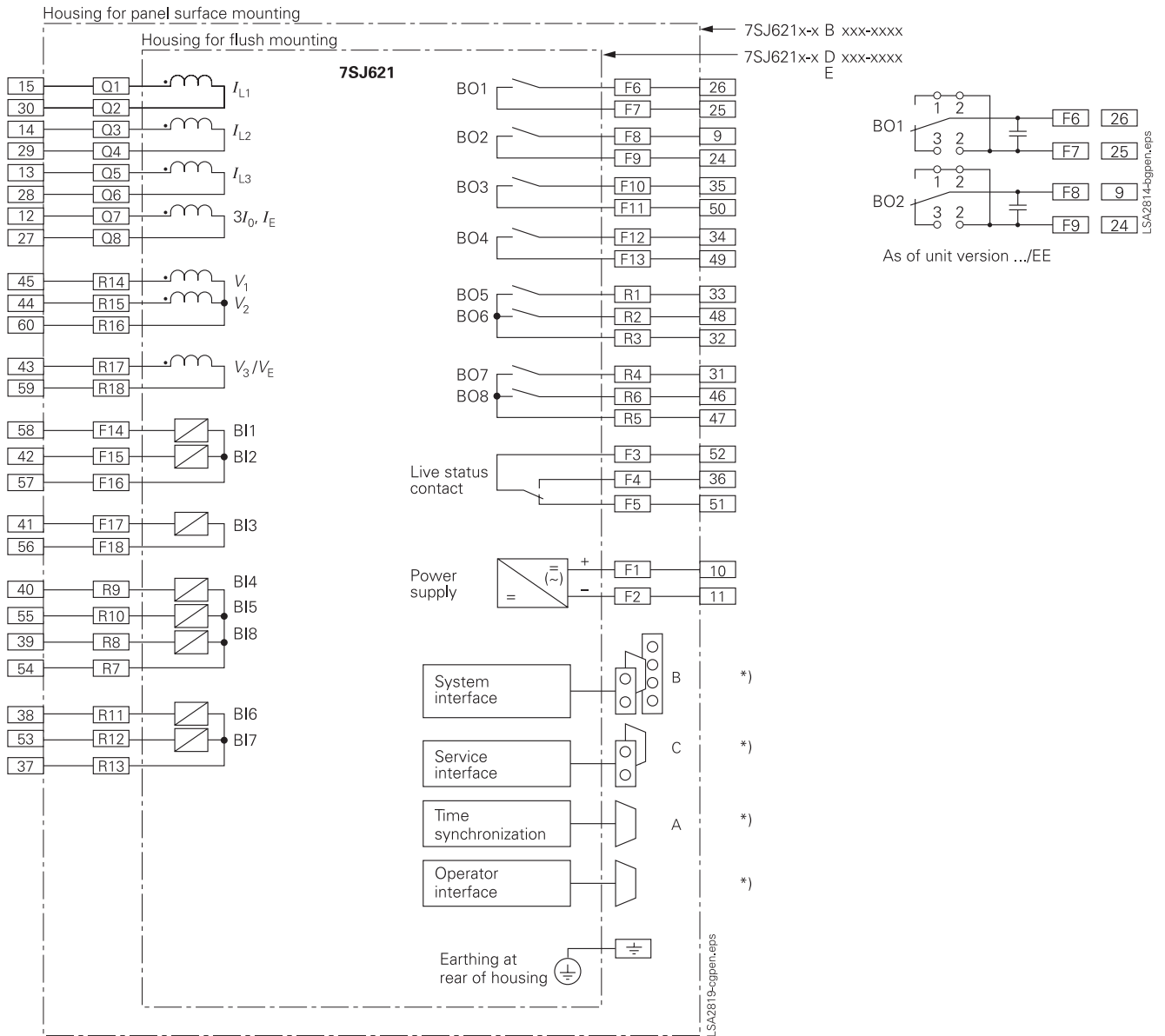

Fig. 5/102 7SJ621 connection diagram

*) For pinout of communication ports see part 16 of this catalog.
 For the allocation of the terminals of the panel surface mounting version refer to the manual (<http://www.siprotec.com>).

Connection diagram

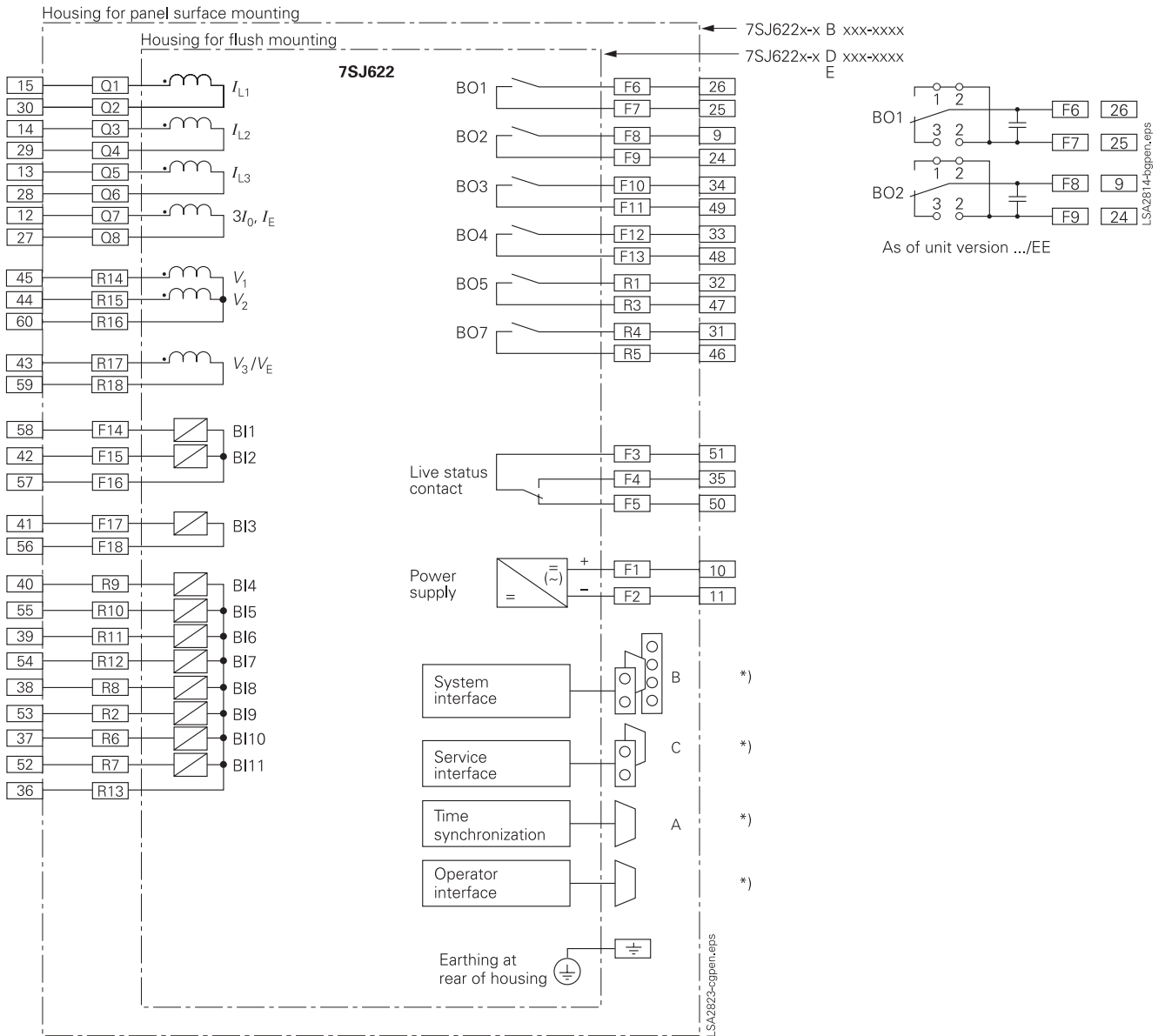

Fig. 5/103 7SJ622 connection diagram

*) For pinout of communication ports see part 16 of this catalog.
 For the allocation of the terminals of the panel surface mounting version refer to the manual (<http://www.siprotec.com>).

Dimension drawings in mm / inch

Dimension drawings for SIPROTEC 4
1/3 x 19" housing (7XP20)

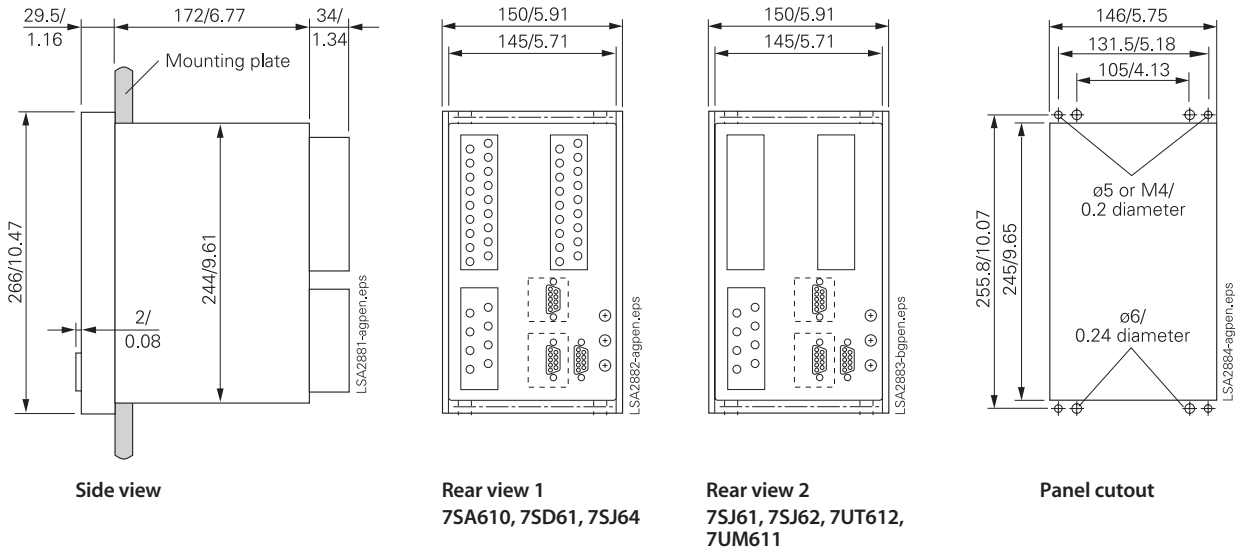

Fig. 16/22
Housing for panel flush mounting/
cubicle mounting (1/3 x 19")

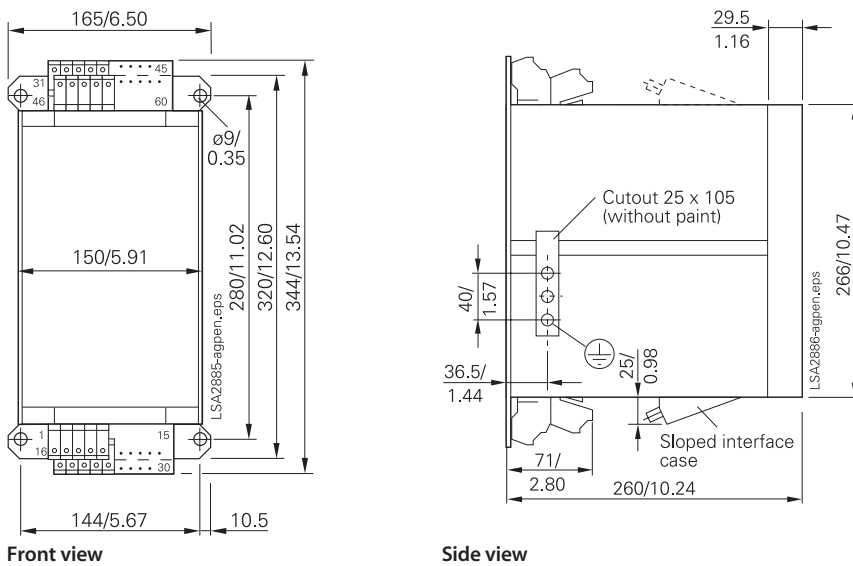

Fig. 16/23
1/3 x 19" surface-mounting housing