

# Product datasheet

Specifications

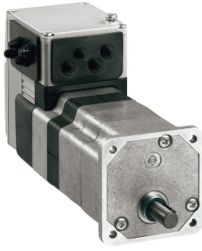

## brushless dc motor 24..48 V - Ethernet Powerlink interface - L = 174 mm - 115:1

ILE2P661PB1A4

⚠ Discontinued on: 15 Jun 2023

⚠ To be end-of-service on: 31 Dec 2026

⚠ Discontinued - Service only

## Main

Range of product	Lexium integrated drive
Product or component type	Motion integrated drive
Device short name	ILE
Motor type	Brushless DC motor
Number of motor poles	6
Network number of phases	Single phase
[Us] rated supply voltage	48 V 24 V
Network type	DC
Communication interface	Ethernet Powerlink, integrated
Length	174 mm
Winding type	Medium speed of rotation and medium torque
Electrical connection	Printed circuit board connector
Holding brake	Without
Gear box type	Straight teeth gear, 4 stages
Reduction ratio	115:1 (3675:32)
Nominal speed	35 rpm at 24 V 44 rpm at 48 V
Nominal torque	12 N.m at 24 V 12 N.m at 48 V

## Complementary

Transmission rate	100 Mbits
Mounting support	Flange
Motor flange size	66 mm
Number of motor stacks	1
Centring collar diameter	16 mm
Centring collar depth	4 mm
Number of mounting holes	4
Mounting holes diameter	4.4 mm
Circle diameter of the mounting holes	73.54 mm

<b>Feedback type</b>	BLDC encoder
<b>Shaft end</b>	Keyed
<b>Second shaft</b>	Without second shaft end
<b>Shaft diameter</b>	10 mm
<b>Shaft length</b>	25 mm
<b>Key width</b>	16 mm
<b>Supply voltage limits</b>	18...55.2 V
<b>Current consumption</b>	7000 mA peak 5500 mA maximum continuous
<b>Associated fuse rating</b>	16 A
<b>Commissioning interface</b>	RS485 Modbus TCP (9.6, 19.2 and 38.4 kbauds)
<b>Input/output type</b>	4 signals (each be used as input or output)
<b>Voltage state 0 guaranteed</b>	-3...4.5 V
<b>Voltage state 1 guaranteed</b>	15...30 V
<b>Discrete input current</b>	10 mA at 24 V on/STO_A for safety input 3 mA at 24 V on/STO_B for safety input 2 mA at 24 V for 24 V signal interface
<b>Discrete output voltage</b>	23...25 V
<b>Maximum switching current</b>	100 mA per output 200 mA total
<b>Protection type</b>	Short circuit of the output voltage Overload of output voltage Safe torque off
<b>Maximum supply current</b>	0.1 A (power stage disabled) 6.8 A at 24 V 3.8 A at 48 V
<b>Nominal output power</b>	54 W at 24 V 68 W at 48 V
<b>Peak stall torque</b>	24.72 N.m at 24 V 24.72 N.m at 48 V
<b>Continuous stall torque</b>	14 N.m
<b>Detent torque</b>	9.19 N.m
<b>Speed feedback resolution</b>	12 points/turn motor 0.26° gearbox output
<b>Accuracy error</b>	+/- 0.5 point
<b>Maximum torsional backlash</b>	1 °
<b>Rotor inertia</b>	1962 kg.cm <sup>2</sup>
<b>Maximum mechanical speed</b>	44 rpm
<b>Maximum radial force Fr</b>	200 N (long-term operation) 200 N (short-term operation)
<b>Maximum axial force Fa</b>	10 N (long-term operation) 80 N (short-term operation)
<b>Service life in hours</b>	2500 h bearing short-term operation 15000 h bearing long-term operation
<b>Marking</b>	CE
<b>Type of cooling</b>	Natural convection
<b>Net weight</b>	1.85 kg

## Environment

<b>Standards</b>	EN/IEC 61800-3 IEC 60072-1 IEC 61800-3, Ed 2 EN 61800-3 : 2001-02 EN 50347 EN 61800-3:2001, second environment EN/IEC 50178
<b>Product certifications</b>	UL cUL TÜV
<b>Ambient air temperature for operation</b>	40...55 °C (with power derating of 2 % per °C) 0...40 °C (without derating)
<b>Permissible ambient air temperature around the device</b>	105 °C power amplifier 110 °C motor
<b>Ambient air temperature for storage</b>	-25...70 °C
<b>Operating altitude</b>	<= 1000 m without derating
<b>Relative humidity</b>	15...85 % without condensation
<b>Vibration resistance</b>	20 m/s <sup>2</sup> (f= 10...500 Hz) 10 cycles conforming to EN/IEC 60068-2-6
<b>Shock resistance</b>	150 m/s <sup>2</sup> 1000 shocks conforming to EN/IEC 60068-2-29
<b>IP degree of protection</b>	IP41 shaft bushing: conforming to EN/IEC 60034-5 IP54 total except shaft bushing: conforming to EN/IEC 60034-5

## Packing Units

<b>Unit Type of Package 1</b>	PCE
<b>Number of Units in Package 1</b>	1
<b>Package 1 Height</b>	8.0 cm
<b>Package 1 Width</b>	18.5 cm
<b>Package 1 Length</b>	35.5 cm
<b>Package 1 Weight</b>	2.8 kg

## Contractual warranty

<b>Warranty (in months)</b>	18
-----------------------------	----



## Environmental Data

Schneider Electric aims to achieve Net Zero status by 2050 through supply chain partnerships, lower impact materials, and circularity via our ongoing “Use Better, Use Longer, Use Again” campaign to extend product lifetimes and recyclability.

[Environmental Data explained >](#)

[How we assess product sustainability >](#)



### Environmental footprint

[Environmental Disclosure](#)

[Product Environmental Profile](#)

## Use Better



### Materials and Substances

SCIP Number

C2ce416c-ac1e-4e66-863f-bde9b6d94d11

EU RoHS Directive

[Compliant By Exemption](#)

REACH Regulation

[Reference contains Substances of Very High Concern above the threshold](#)

PVC free

Yes

## Use Longer



### Lifetime extension

Repair

No

## Use Again



### Repack and remanufacture

End of life manual availability

[End of Life Information](#)

Dimensions

Integrated Drive with Straight Teeth Gear

Dimensions

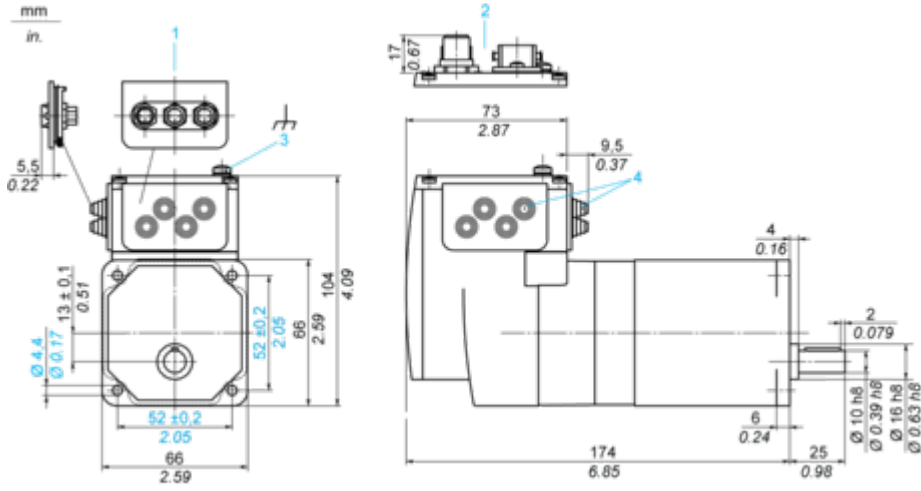

- 1 Accessories: I/O signal insert with industrial connectors
- 2 Option: industrial connectors
- 3 Earth (ground) terminal
- 4 Accessories: cable entries  $\varnothing = 3 \dots 9 \text{ mm} / 0.12 \dots 0.35 \text{ in.}$

Wiring

Connection Example with 4 I/O Signals

---



PerformanceCurves

Torque Characteristics

---

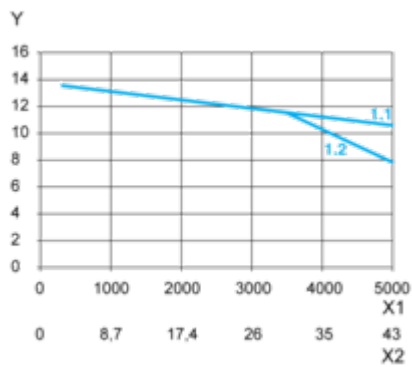

- X1 Speed of rotation of motor in rpm
- X2 Speed of rotation of gearing in rpm
- Y Torque in Nm
- 1.1 Max. torque at 24 V
- 1.2 Max. torque at 36 V