

Product datasheet

Specifications



servo motor BSH, Lexium 32,
27.8N.m, 3000rpm, 140mm,
untapped shaft, Sincos single turn,
with brake, IP50

BSH1403T01F2P

! Discontinued

! Discontinued on: 9 Feb 2023

Main

Device short name	BSH
Product or component type	Servo motor
Maximum mechanical speed	4800 rpm
Continuous stall torque	27.8 N.m for LXM32.D72N4 at 24 A, 400 V, three phase 27.8 N.m for LXM32.D72N4 at 24 A, 480 V, three phase
Peak stall torque	90.2 N.m for LXM32.D72N4 at 24 A, 400 V, three phase 90.2 N.m for LXM32.D72N4 at 24 A, 480 V, three phase
Nominal output power	4100 W for LXM32.D72N4 at 24 A, 400 V, three phase 4100 W for LXM32.D72N4 at 24 A, 480 V, three phase
Nominal torque	12.9 N.m for LXM32.D72N4 at 24 A, 400 V, three phase 12.9 N.m for LXM32.D72N4 at 24 A, 480 V, three phase
Nominal speed	3000 rpm for LXM32.D72N4 at 24 A, 400 V, three phase 3000 rpm for LXM32.D72N4 at 24 A, 480 V, three phase
Product compatibility	LXM32.D72N4 at 400 V three phase LXM32.D72N4 at 480 V three phase
Shaft end	Untapped
IP degree of protection	IP50 standard
Speed feedback resolution	131072 points/turn
Holding brake	With
Mounting support	International standard
Electrical connection	Rotatable right-angled connectors

Complementary

Range compatibility	Lexium 32
supply voltage max	480 V
Network number of phases	Three phase
Continuous stall current	22.3 A
maximum continuous power	3.3 W
Maximum current Irms	72 A for LXM32.D72N4
Maximum permanent current	81.3 A
Switching frequency	8 kHz
Second shaft	Without second shaft end
Shaft diameter	24 mm

Shaft length	50 mm
Feedback type	Single turn SinCos Hiperface
Holding torque	36 N.m holding brake
Motor flange size	140 mm
Number of motor stacks	3
Torque constant	1.25 N.m/A at 120 °C
Back emf constant	105 V/krpm at 120 °C
Rotor inertia	14.48 kg.cm ²
Stator resistance	0.4 Ohm at 20 °C
Stator inductance	5.1 mH at 20 °C
Stator electrical time constant	12.75 ms at 20 °C
Maximum radial force Fr	1780 N at 3000 rpm 2030 N at 2000 rpm 2560 N at 1000 rpm
Maximum axial force Fa	0.2 x Fr
Brake pull-in power	26 W
Type of cooling	Natural convection
Length	365.5 mm
Centring collar diameter	130 mm
Centring collar depth	3.5 mm
Number of mounting holes	4
Mounting holes diameter	11 mm
Circle diameter of the mounting holes	165 mm
Net weight	23 kg
Sizing reference	BSH1403T
Network number of phases	3
Accuracy error [angular]	1.4 °
Temperature copper hot	120 °C
Temperature magnet hot	100 °C
Temperature magnet rt	20 °C

Packing Units

Unit Type of Package 1	PCE
Number of Units in Package 1	1
Package 1 Height	27 cm
Package 1 Width	27 cm
Package 1 Length	48.2 cm
Package 1 Weight	13.29 kg

Contractual warranty

Warranty (in months)	18
----------------------	----



Environmental Data

Schneider Electric aims to achieve Net Zero status by 2050 through supply chain partnerships, lower impact materials, and circularity via our ongoing “Use Better, Use Longer, Use Again” campaign to extend product lifetimes and recyclability.

[Environmental Data explained >](#)

[How we assess product sustainability >](#)

Use Better



Materials and Substances

EU RoHS Directive

[Compliant By Exemption](#)

Use Longer



Lifetime extension

Repair

No

Use Again



Repack and remanufacture

End of life manual availability

No need of specific recycling operations

Dimensions Drawings

Servo Motors Dimensions

Example with Straight Connectors

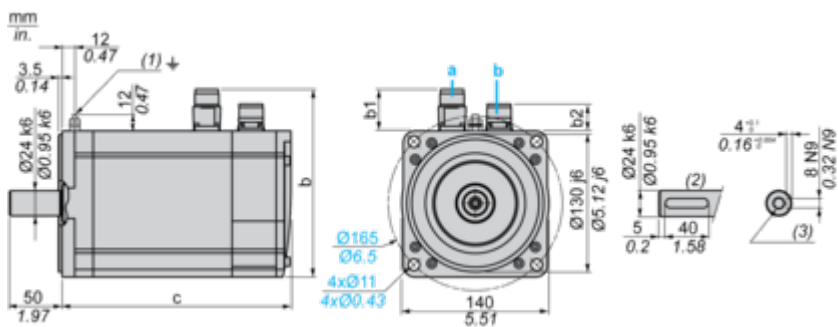

- a: Power supply for servo motor brake
- b: Power supply for servo motor encoder
- (1) M4 screw
- (2) Shaft end, keyed slot (optional)
- (3) For screws M8 x 19 mm/M8 x 0.75 in.

Dimensions in mm

Straight connectors			Rotatable angled connectors			c (without brake)	c (with brake)
b	b1	b2	b	b1	b2		
192.5	54	25.5	198.5	60	39.5	328	366

Dimensions in in.

Straight connectors			Rotatable angled connectors			c (without brake)	c (with brake)
b	b1	b2	b	b1	b2		
7.57	2.12	1.00	7.81	2.36	1.55	12.91	14.40

Performance Curves

400 V 3-Phase Supply Voltage

Torque/Speed Curves

Servo motor with LXM32-D72N4 servo drive

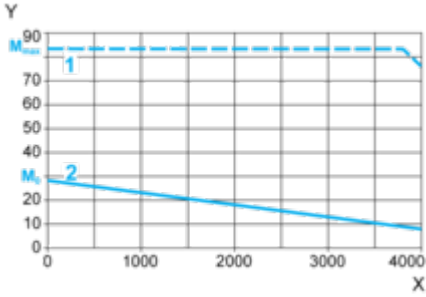

X Speed in rpm

Y Torque in Nm

1 Peak torque

2 Continuous torque

480 V 3-Phase Supply Voltage

Torque/Speed Curves

Servo motor with LXM32•D72N4 servo drive

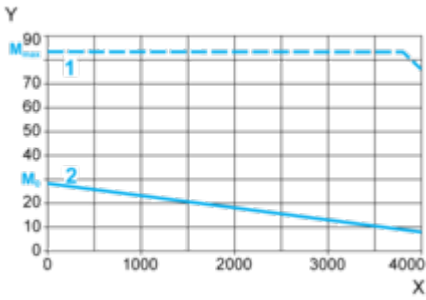

X Speed in rpm

Y Torque in Nm

1 Peak torque

2 Continuous torque