

Programmable Controller

CC-Link IE Field Network Digital-Analog Converter Module User's Manual

-NZ2GF2BN-60DA4
-NZ2EX2B-60DA4

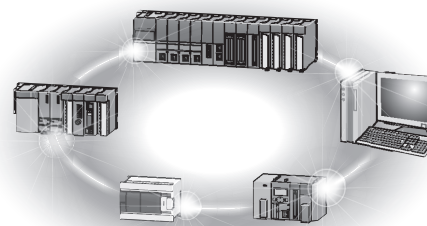

● SAFETY PRECAUTIONS ●

(Read these precautions before using this product.)

Before using this product, please read this manual and the relevant manuals carefully and pay full attention to safety to handle the product correctly.

The precautions given in this manual are concerned with this product only. For the safety precautions of the programmable controller system, refer to the user's manual for the CPU module used.

In this manual, the safety precautions are classified into two levels: "⚠ WARNING" and "⚠ CAUTION".



Indicates that incorrect handling may cause hazardous conditions, resulting in death or severe injury.



Indicates that incorrect handling may cause hazardous conditions, resulting in minor or moderate injury or property damage.

Under some circumstances, failure to observe the precautions given under "⚠ CAUTION" may lead to serious consequences.

Observe the precautions of both levels because they are important for personal and system safety.

Make sure that the end users read this manual and then keep the manual in a safe place for future reference.

[Design Precautions]

⚠ WARNING

- When a communication failure occurs in the network, data in the master module are held. Check Data link status (each station) (SW00B0 to SW00B7) and configure an interlock circuit in the program to ensure that the entire system will operate safely.
- Do not use any "use prohibited" signals as a remote input or output signal. These signals are reserved for system use. Do not write any data to the "use prohibited" areas in the remote register. Doing so may result in an accident due to an incorrect output or malfunction.
- Configure safety circuits external to the programmable controller to ensure that the entire system operates safely even when a fault occurs in the external power supply or the programmable controller. Failure to do so may result in an accident due to an incorrect output or malfunction.
 - (1) The status of analog output depends on the setting of various functions that control the analog output. Exercise great caution when setting those functions. For details of the status of analog output, refer to Page 93, Section 8.7.
 - (2) Due to failure of the output element or internal circuit, normal output may not be obtained correctly. Configure an external circuit for monitoring output signals that could cause a serious accident.

[Design Precautions]

CAUTION

- Do not install the control lines or communication cables together with the main circuit lines or power cables. Keep a distance of 100mm or more between them. Failure to do so may result in malfunction due to noise.
- At power-on/off, a voltage may occur or a current may flow between output terminals for a moment. In this case, start the control after analog outputs become stable.

[Installation Precautions]

WARNING

- Shut off the external power supply (all phases) used in the system before mounting or removing a module. Failure to do so may result in electric shock or cause the module to fail or malfunction.

[Installation Precautions]

CAUTION

- Use the module in an environment that meets the general specifications in this manual. Failure to do so may result in electric shock, fire, malfunction, or damage to or deterioration of the product.
- Do not directly touch any conductive parts and electronic components of the module. Doing so can cause malfunction or failure of the module.
- After the first use of the product, do not connect/remove the extension module more than 50 times (IEC 61131-2 compliant). Exceeding the limit may cause malfunction.
- To connect an extension module to a main module, engage the respective connectors and securely lock the module joint levers. Incorrect interconnection may cause malfunction, failure, or drop of the extension module.
- Securely connect the cable connectors. Poor contact may cause malfunction.

[Wiring Precautions]

WARNING

- Shut off the external power supply (all phases) used in the system before wiring. Failure to do so may result in electric shock or cause the module to fail or malfunction.

[Wiring Precautions]

CAUTION

- Individually ground the FG terminal of the programmable controller with a ground resistance of 100 ohms or less. Failure to do so may result in electric shock or malfunction.
- Tighten any unused terminal screws within the specified torque range. Undertightening can cause a short circuit due to contact with a solderless terminal.

[Wiring Precautions]

CAUTION

- Use applicable solderless terminals and tighten them within the specified torque range. If any spade solderless terminal is used, it may be disconnected when a terminal block screw comes loose, resulting in failure.
- Check the rated voltage and terminal layout before wiring to the module, and connect the cables correctly. Connecting a power supply with a different voltage rating or incorrect wiring may cause a fire or failure.
- Tighten the terminal block screws within the specified torque range. Undertightening can cause short circuit, fire, or malfunction. Overtightening can damage the screw and/or module, resulting in drop, short circuit, fire, or malfunction.
- Prevent foreign matter such as dust or wire chips from entering the module. Such foreign matter can cause a fire, failure, or malfunction.
- Place the cables in a duct or clamp them. If not, dangling cable may swing or inadvertently be pulled, resulting in damage to the module or cables or malfunction due to poor contact.
- Do not install the control lines or communication cables together with the main circuit lines or power cables. Keep a distance of 100mm or more between them. Failure to do so may result in malfunction due to noise.
- When disconnecting the cable from the module, do not pull the cable by the cable part. For the cable with connector, hold the connector part of the cable. For the cable connected to the terminal block, loosen the terminal screw. Pulling the cable connected to the module may result in malfunction or damage to the module or cable.
- When an overcurrent caused by an error of an external device or a failure of the programmable controller flows for a long time, it may cause smoke and fire. To prevent this, configure an external safety circuit, such as a fuse.
- Mitsubishi Electric programmable controllers must be installed in control panels. Wiring and replacement of a module must be performed by qualified maintenance personnel with knowledge of protection against electric shock. For wiring methods, refer to "INSTALLATION AND WIRING" in this manual.

[Startup and Maintenance Precautions]

WARNING

- Do not touch any terminal while power is on. Doing so will cause electric shock or malfunction.
- Shut off the external power supply (all phases) used in the system before cleaning the module or retightening the terminal block screws or connector screws. Failure to do so may cause the module to fail or malfunction.

[Startup and Maintenance Precautions]

CAUTION

- Do not disassemble or modify the module. Doing so may cause failure, malfunction, injury, or a fire.
- Do not drop or apply strong shock to the module. Doing so may damage the module.
- Shut off the external power supply (all phases) used in the system before mounting or removing a module. Failure to do so may cause the module to fail or malfunction.
- After the first use of the product, do not connect/remove the terminal block more than 50 times (IEC 61131-2 compliant). Exceeding the limit may cause malfunction.
- Before handling the module or connection cables, touch a conducting object such as a grounded metal to discharge the static electricity from the human body. Failure to do so may cause the module to fail or malfunction.
- Startup and maintenance of a control panel must be performed by qualified maintenance personnel with knowledge of protection against electric shock. Lock the control panel so that only qualified maintenance personnel can operate it.

[Disposal Precautions]

CAUTION

- When disposing of this product, treat it as industrial waste.

● CONDITIONS OF USE FOR THE PRODUCT ●

- (1) Mitsubishi programmable controller ("the PRODUCT") shall be used in conditions;
- i) where any problem, fault or failure occurring in the PRODUCT, if any, shall not lead to any major or serious accident; and
 - ii) where the backup and fail-safe function are systematically or automatically provided outside of the PRODUCT for the case of any problem, fault or failure occurring in the PRODUCT.
- (2) The PRODUCT has been designed and manufactured for the purpose of being used in general industries. MITSUBISHI SHALL HAVE NO RESPONSIBILITY OR LIABILITY (INCLUDING, BUT NOT LIMITED TO ANY AND ALL RESPONSIBILITY OR LIABILITY BASED ON CONTRACT, WARRANTY, TORT, PRODUCT LIABILITY) FOR ANY INJURY OR DEATH TO PERSONS OR LOSS OR DAMAGE TO PROPERTY CAUSED BY the PRODUCT THAT ARE OPERATED OR USED IN APPLICATION NOT INTENDED OR EXCLUDED BY INSTRUCTIONS, PRECAUTIONS, OR WARNING CONTAINED IN MITSUBISHI'S USER, INSTRUCTION AND/OR SAFETY MANUALS, TECHNICAL BULLETINS AND GUIDELINES FOR the PRODUCT.

("Prohibited Application")

Prohibited Applications include, but not limited to, the use of the PRODUCT in;

- Nuclear Power Plants and any other power plants operated by Power companies, and/or any other cases in which the public could be affected if any problem or fault occurs in the PRODUCT.
- Railway companies or Public service purposes, and/or any other cases in which establishment of a special quality assurance system is required by the Purchaser or End User.
- Aircraft or Aerospace, Medical applications, Train equipment, transport equipment such as Elevator and Escalator, Incineration and Fuel devices, Vehicles, Manned transportation, Equipment for Recreation and Amusement, and Safety devices, handling of Nuclear or Hazardous Materials or Chemicals, Mining and Drilling, and/or other applications where there is a significant risk of injury to the public or property.

Notwithstanding the above, restrictions Mitsubishi may in its sole discretion, authorize use of the PRODUCT in one or more of the Prohibited Applications, provided that the usage of the PRODUCT is limited only for the specific applications agreed to by Mitsubishi and provided further that no special quality assurance or fail-safe, redundant or other safety features which exceed the general specifications of the PRODUCTS are required. For details, please contact the Mitsubishi representative in your region.

INTRODUCTION

Thank you for purchasing the CC-Link IE Field Network digital-analog converter module (hereafter abbreviated as D/A converter module).

This manual describes the procedures, system configuration, parameter settings, functions, and troubleshooting of a D/A converter module.

Before using this product, please read this manual and the relevant manuals carefully and develop familiarity with the functions and performance of the D/A converter module to handle the product correctly.

When applying the program examples introduced in this manual to an actual system, ensure the applicability and confirm that it will not cause system control problems.

■ Relevant modules: NZ2GF2BN-60DA4, NZ2EX2B-60DA4

Remark

Unless otherwise specified, this manual describes the program examples in which the remote I/O signals and remote registers are assigned for a D/A converter module as follows.

- Remote input signal: RX0 to RX1F (main D/A converter module), RX20 to RX2F (extension D/A converter module)
- Remote output signal: RY0 to RY1F (main D/A converter module), RY20 to RY2F (extension D/A converter module)
- Remote register (RWr): RWr0 to RWrF (main D/A converter module), RWr10 to RWr1F (extension D/A converter module)
- Remote register (RWw): RWw0 to RWwF (main D/A converter module), RWw10 to RWw1F (extension D/A converter module)

For the assignment of remote I/O signals and remote registers, refer to the following.

 User's manual for the master/local module used

RELEVANT MANUALS

(1) CC-Link IE Field Network (relevant) manuals

When using the CC-Link IE Field Network for the first time, refer to the CC-Link IE Field Network Master/Local Module User's Manual or Simple Motion Module Use's Manual first. The following shows the structure of the CC-Link IE Field Network manuals.

Manual name [manual number (model code)]	Description
MELSEC-Q CC-Link IE Field Network Master/Local Module User's Manual [SH-080917ENG, 13JZ47]	Overview of the CC-Link IE Field Network, and specifications, procedures before operation, system configuration, installation, wiring, settings, functions, programming, and troubleshooting of the QJ71GF11-T2
MELSEC-L CC-Link IE Field Network Master/Local Module User's Manual [SH-080972ENG, 13JZ54]	Overview of the CC-Link IE Field Network, and specifications, procedures before operation, system configuration, installation, wiring, settings, functions, programming, and troubleshooting of the LJ71GF11-T2
MELSEC iQ-R Ethernet/CC-Link IE User's Manual (Startup) [SH-081256ENG, 13JX09]	Specifications, procedures before operation, system configuration, wiring, and communication examples of Ethernet, CC-Link IE Controller Network, and CC-Link IE Field Network
MELSEC iQ-R CC-Link IE Field Network User's Manual (Application) [SH-081259ENG, 13JX18]	Functions, parameter settings, programming, troubleshooting, I/O signals, and buffer memory of CC-Link IE Field Network
MELSEC iQ-R Inter-Module Synchronization Function Reference Manual [SH-081401ENG]	Inter-module synchronization function, which controls multiple modules synchronously
MELSEC-Q QD77GF Simple Motion Module User's Manual (Network) [IB-0300203, 1XB957]	Functions, programming, and troubleshooting of CC-Link IE Field Network for the QD77GF16
MELSEC-Q QD77GF Simple Motion Module User's Manual (Positioning Control) [IB-0300202, 1XB956]	Specifications of the QD77GF16, information on how to establish a system, maintenance and inspection, and troubleshooting. Also included are functions, programming, and buffer memory for the positioning control of the QD77GF16.
CC-Link IE Field Network Remote I/O Module User's Manual [SH-081114ENG, 13JZ82]	Specifications, procedures before operation, system configuration, installation, wiring, various settings, functions, programming, and troubleshooting of the CC-Link IE Field Network remote I/O module
CC-Link IE Field Network Analog-Digital Converter Module User's Manual [SH-081451ENG, 13JX26]	Specifications, procedures before operation, system configuration, installation, wiring, various settings, functions, programming, and troubleshooting of the CC-Link IE Field Network analog-digital converter module

(2) Operating manual

Manual name [manual number (model code)]	Description
GX Works2 Version 1 Operating Manual (Common) [SH-080779ENG, 13JU63]	System configuration, parameter settings, and online operations of GX Works2, which are common to Simple projects and Structured projects
GX Works3 Operating Manual [SH-081215ENG]	System configuration, parameter settings, and online operations of GX Works3

CONTENTS

SAFETY PRECAUTIONS	1
CONDITIONS OF USE FOR THE PRODUCT	5
INTRODUCTION	6
RELEVANT MANUALS	7
MANUAL PAGE ORGANIZATION	11
TERMS	12
PACKING LIST	14
<hr/>	
CHAPTER 1 D/A CONVERTER MODULE	15
<hr/>	
1.1 Application	15
1.2 Features	16
<hr/>	
CHAPTER 2 PART NAMES	19
<hr/>	
2.1 Main D/A Converter Module	19
2.2 Extension D/A Converter Module	22
<hr/>	
CHAPTER 3 SPECIFICATIONS	23
<hr/>	
3.1 General Specifications	23
3.2 Performance Specifications	24
3.2.1 Main D/A converter module	24
3.2.2 Extension D/A converter module	26
3.3 How to Calculate Current Consumption	28
3.4 Function List	29
3.5 List of Remote I/O Signals	31
3.5.1 Main D/A converter module	32
3.5.2 Extension D/A converter module	33
3.6 List of Remote Registers	34
3.6.1 Main D/A converter module	35
3.6.2 Extension D/A converter module	36
3.7 List of Remote Buffer Memory Areas	37
3.7.1 Main D/A converter module	39
3.7.2 Extension D/A converter module	43
<hr/>	
CHAPTER 4 PROCEDURES BEFORE OPERATION	45
<hr/>	
CHAPTER 5 SYSTEM CONFIGURATION	47
<hr/>	
5.1 System Configuration with D/A Converter Module	47
5.2 Applicable Systems	48
<hr/>	
CHAPTER 6 INSTALLATION AND WIRING	50
<hr/>	
6.1 Station Number Setting	50
6.2 Installation Environment and Installation Position	51
6.2.1 Installation environment	51
6.2.2 Installation position	51

6.2.3	Installation direction	52
6.3	Installation.	53
6.3.1	How to connect an extension module	53
6.3.2	Mounting modules on a DIN rail.	55
6.4	Wiring to Terminal Block for Module Power Supply and FG	58
6.5	Wiring of Ethernet Cable.	60
6.6	Wiring of Terminal Block and External Devices	63

CHAPTER 7 VARIOUS SETTINGS	69
-----------------------------------	-----------

7.1	Parameter Settings	69
7.2	How to Change the Parameters	76
7.2.1	Changing the network configuration.	76
7.2.2	Changing the parameters without changing the network configuration	80
7.3	Offset/Gain Setting	83

CHAPTER 8 FUNCTIONS	85
----------------------------	-----------

8.1	Mode Shift at Power-On	85
8.2	Drive Mode Switch	86
8.3	D/A Conversion Enable/Disable Function.	88
8.4	D/A Output Enable/Disable Function	88
8.5	Conversion Speed and Conversion Period.	89
8.6	Range Switching Function	92
8.7	Analog Output HOLD/CLEAR Function	93
8.8	Cyclic Data Update Watch Function	95
8.9	Scaling Function	96
8.10	Shift Function	101
8.11	Digital Value Range Check Function	105
8.12	Alert Output Function	107
8.13	Trigger Output Function	110
8.14	CC-Link IE Field Network Synchronous Communication Function.	120
8.15	Error Notification Function	126
8.16	Functions with an Extension Module Connected	129
8.16.1	Available functions with an extension I/O converter module connected	129
8.16.2	Functions with the extension D/A converter module connected.	133
8.16.3	Functions with the extension A/D converter module connected.	134
8.17	CC-Link IE Field Network Diagnostic Function.	135

CHAPTER 9 PROGRAMMING	137
------------------------------	------------

9.1	Precautions for Programming.	137
9.2	Programming Procedure.	138
9.3	Program Example.	138

CHAPTER 10 MAINTENANCE AND INSPECTION	148
--	------------

CHAPTER 11 TROUBLESHOOTING **150**

11.1	How to Check Error Codes and Alarm Codes	150
11.2	Error Code List	154
11.2.1	Main D/A converter module	154
11.2.2	Extension D/A converter module	159
11.3	Alarm Code List	161
11.3.1	Main D/A converter module	161
11.3.2	Extension D/A converter module	161
11.4	Checking the LEDs	162
11.4.1	Main D/A converter module	162
11.4.2	Extension D/A converter module	165
11.5	Unit Test	166
11.6	Troubleshooting by Symptom	167
11.6.1	Main D/A converter module	167
11.6.2	Extension D/A converter module	169

APPENDICES **170**

Appendix 1	Details of Remote I/O Signals	170
Appendix 1.1	Remote input signals	170
Appendix 1.2	Remote output signals	177
Appendix 2	Details of Remote Registers	180
Appendix 3	Details of Remote Buffer Memory	185
Appendix 4	I/O Conversion Characteristics of D/A Conversion	205
Appendix 5	Accuracy of D/A Conversion	208
Appendix 6	Processing Time of CC-Link IE Field Network	209
Appendix 7	EMC and Low Voltage Directives	210
Appendix 7.1	Measures to comply with the EMC Directive	210
Appendix 7.2	Requirements to compliance with the Low Voltage Directive	216
Appendix 8	How to Check Serial Number and Function Version	217
Appendix 9	Comparison with NZ2GF2B-60DA4	219
Appendix 9.1	Comparison of performance specifications	219
Appendix 9.2	Functional comparison	219
Appendix 9.3	About replacement from NZ2GF2B-60DA4 to NZ2GF2BN-60DA4	220
Appendix 10	External Dimensions	221
Appendix 10.1	Main D/A converter module	221
Appendix 10.2	Extension D/A converter module	221

INDEX **222**

REVISIONS	224
WARRANTY	225
TRADEMARKS	226

MANUAL PAGE ORGANIZATION

In this manual, pages are organized and the symbols are used as shown below.

The following illustration is for explanation purpose only, and should not be referred to as an actual documentation.

The illustration shows a manual page titled "7.1.1 Setting method" with various annotations explaining symbols and layout elements:

- ""** is used for window names and items.
- 1.** shows operating procedures.
- shows mouse operations.*1
- []** is used for items in the menu bar and the project window.
- Ex.** shows setting or operating examples.
- shows reference manuals.
- shows reference pages.
- Point** shows notes that require attention.
- Remark** shows useful information.

The manual page content includes:

CHAPTER 7 VARIOUS SETTINGS

7.1.1 Setting method

(1) Setting parameters

(a) Operating procedure

1. Open the "PLC Parameter" dialog box.
Project window -> [Parameter] -> [PLC parameter]
2. Select the "IO Assignment" tab.

Item	Description	Reference
Type	Select the type of the connected module.	Page 74, Section 7.1.2
Model Name	Select the model name of the connected module.	Page 74, Section 7.1.3
Points	Set the number of points assigned to each slot.	Page 74, Section 7.1.4
Start XY	Specify a start I/O number for each slot.	Page 74, Section 7.1.5
Switch setting	Configure the switch setting of the built-in I/O or intelligent function modules.	Page 74, Section 7.1.6
Unset setting	Set the following: - Error Time Output Mode - PLC Operation Mode at HW Error - I/O Response Time	Page 75, Section 7.1.7

Setting "Start XY" enables modification on the start I/O numbers assigned to connected modules.
Ex. When "1000" is specified in "Start XY" to the slot where a 16-point module is connected, the assignment range of an input module is changed to X1000 to X100F.

For details, refer to the following:
 MELSEC-L CPU Module User's Manual (Function Explanation, Program Fundamentals)

Point
 Set the type of the connected module in "Type". Setting a different type results in "SPUNIT LAV ERR."
 For the intelligent function module, the I/O points must also be the same in addition to the I/O assignment setting.
 (Page 30, Section 4.2.2)

Remark
 When an intelligent module is connected, I/O assignment can be omitted by selecting connected modules from "Intelligent Function Module" in the Project window.

73

*1 The mouse operation example (for GX Works2) is provided below.





The screenshot shows the MELSOFT Series GX Works2 software interface with the following annotations:

- Menu bar**: **Ex.** [Online] => [Write to PLC...]
Select [Online] on the menu bar, and then select [Write to PLC...].
- A window selected in the view selection area is displayed.**: **Ex.** Project window => [Parameter] => [PLC Parameter]
Select [Project] from the view selection area to open the Project window. In the Project window, expand [Parameter] and select [PLC Parameter].
- View selection area**: Shows the Project, User Library, and Connection Destination options.

TERMS

Unless otherwise specified, this manual uses the following terms.

Term	Description
Buffer memory	A memory in an intelligent function module, where data (such as setting values and monitoring values) exchanged with a CPU module are stored
CC-Link IE Field Network	A high-speed and large-capacity open field network that is based on Ethernet (1000BASE-T)
Cyclic transmission	A function by which data are periodically exchanged among stations on the same network using link devices (RX, RY, RWw, and RWr)
D/A converter module	A generic term for the main D/A converter module and extension D/A converter module
Data link	A generic term for cyclic transmission and transient transmission
Dedicated instruction	An instruction that simplifies programming for using functions of intelligent function modules
Disconnection	A process of stopping data link if a data link error occurs
Extension A/D converter module	The abbreviation for the N22EX2B-60AD4 CC-Link IE Field Network extension analog-digital converter module
Extension analog module	A generic term for the extension A/D converter module and extension D/A converter module
Extension D/A converter module	The abbreviation for the N22EX2BN-60DA4 CC-Link IE Field Network extension digital-analog converter module
Extension I/O module	A generic term for extension modules where a digital signal can be input or output
Extension input module	A generic term for extension modules where digital signals can be input
Extension module	A remote module with no CC-Link IE Field Network communication function. This module cannot be used as a single module. However, connecting the module to the main module will increase the number of I/O points per station.
Extension output module	A generic term for extension modules where digital signals can be output
GX Works2	The product name of the software package for the MELSOFT programmable controllers
GX Works3	
I/O module	Another name for the CC-Link IE Field Network remote I/O module
Intelligent device station	A station that exchanges I/O signals (bit data) and I/O data (word data) with another station by cyclic transmission. This station responds to a transient transmission request from another station and also issues a transient transmission request to another station.
Link device	A device (RX, RY, RWr, or RWw) in a module on CC-Link IE Field Network
Link special register (SW)	Word data that indicates the operating status and data link status of a module on CC-Link IE Field Network
Link special relay (SB)	Bit data that indicates the operating status and data link status of a module on CC-Link IE Field Network
Local station	A station that performs cyclic transmission and transient transmission with the master station and other local stations. The station is controlled by programs in the CPU module or other equivalent modules on the station.
Main A/D converter module	The abbreviation for the N22GF2BN-60AD4 CC-Link IE Field Network main analog-digital converter module
Main analog module	A generic term for the main A/D converter module and main D/A converter module
Main D/A converter module	The abbreviation for the N22GF2BN-60DA4 CC-Link IE Field Network main digital-analog converter module
Main module	A module with the CC-Link IE Field Network communication function, which can be used as a single remote module. Extension modules can be connected to this module.
Master station	A station that controls the entire network. This station can perform cyclic transmission and transient transmission with all stations. Only one master station can be used in a network.
Master/local module	The generic term for the CC-Link IE Field Network master/local module
Network module	A generic term for the following modules: <ul style="list-style-type: none"> • CC-Link IE Field Network module • CC-Link IE Controller Network module • Ethernet interface module • MELSECNET/H module • MELSECNET/10 module
Relay station	A station that includes two or more network modules. Data are passed through this station to stations on other networks
REMFR	The abbreviation for ZP.REMFR.
Remote buffer memory	Buffer memory in a remote device station
Remote device station	A station that exchanges I/O signals (bit data) and I/O data (word data) with another station by cyclic transmission. This station responds to a transient transmission request from another station.
Remote I/O station	A station that exchanges I/O signals (bit data) with the master station by cyclic transmission

Term	Description
Remote input (RX)	Bit data input from a slave station to the master station (For some areas in a local station, data are input in the opposite direction.)  User's manual for the master/local module used
Remote output (RY)	Bit data output from the master station to a slave station (For some areas in a local station, data are output in the opposite direction.)  User's manual for the master/local module used
Remote register (RWr)	Word data input from a slave station to the master station (For some areas in a local station, data are input in the opposite direction.)  User's manual for the master/local module used
Remote register (RWw)	Word data output from the master station to a slave station (For some areas in a local station, data are input in the opposite direction.)  User's manual for the master/local module used
REMTO	The abbreviation for ZP.REMTO.
Reserved station	A station reserved for future use. This station is not actually connected, but counted as a connected station
Return	A process of restarting data link when a station recovers from an error
Simple motion module	The abbreviation for the QD77GF CC-Link IE Field Network simple motion module
Slave station	A generic term for stations other than a master station: local station, remote I/O station, remote device station, and intelligent device station
Transient transmission	A function of communication with another station, which is used when requested by a dedicated instruction or GX Works2

PACKING LIST

The following items are included in the package of this product. Before use, check that all the items are included.

D/A converter module

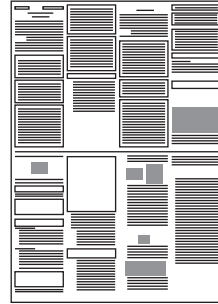
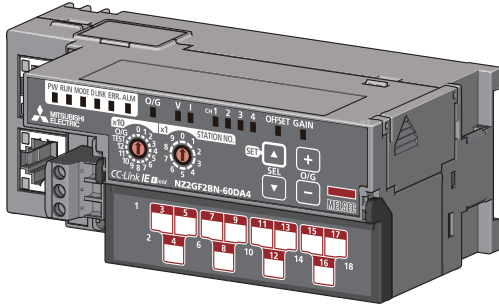

Module (The figure above shows the main D/A converter module.)

Before Using the Product

CHAPTER 1 D/A CONVERTER MODULE

This chapter describes the applications and features of the D/A converter module.

1.1 Application

The D/A converter module converts digital data to analog signals and outputs them to the external devices.

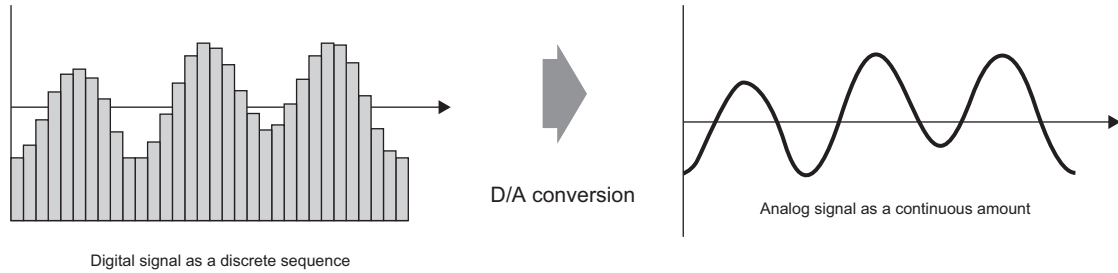

The digital data is set up from the master station.

Using the D/A converter module allows the flow and the temperature to be controlled from the master station.

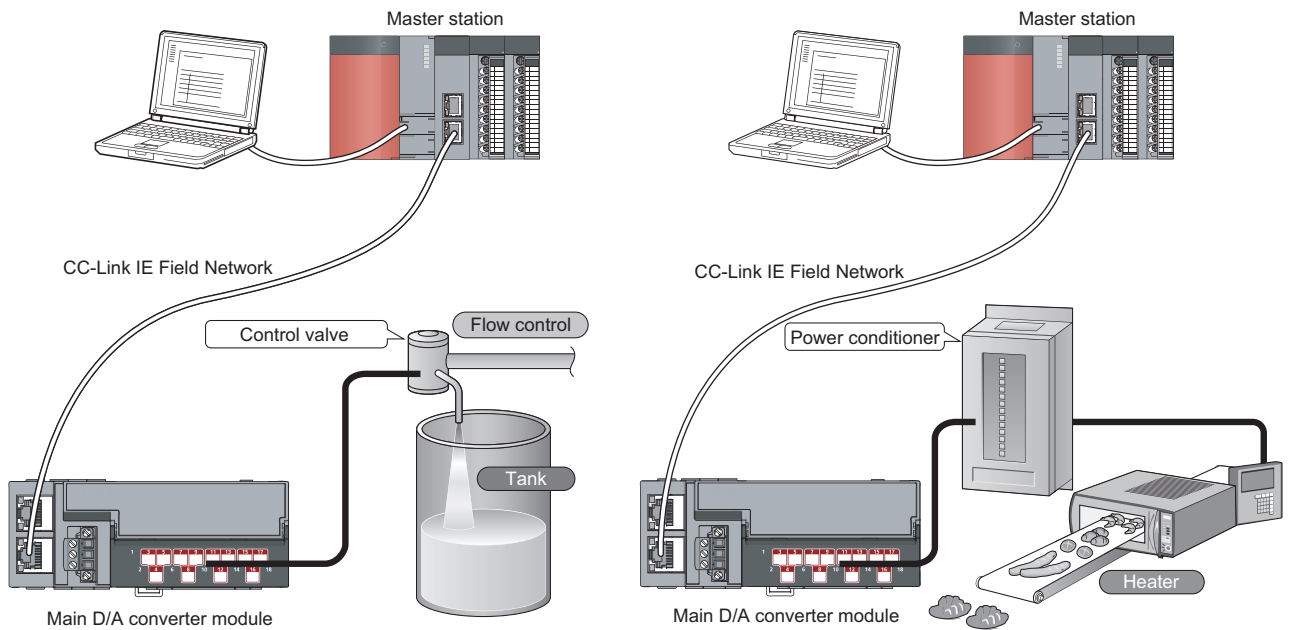

1.1 Application

1.2 Features

(1) Flexible system configuration

The employed connection block type provides the combined use of a main module and an extension module. A flexible configuration can be achieved because various extension modules can be connected. In addition, the main module always monitors the connection status of the extension module, leading to an early detection of connection failure.

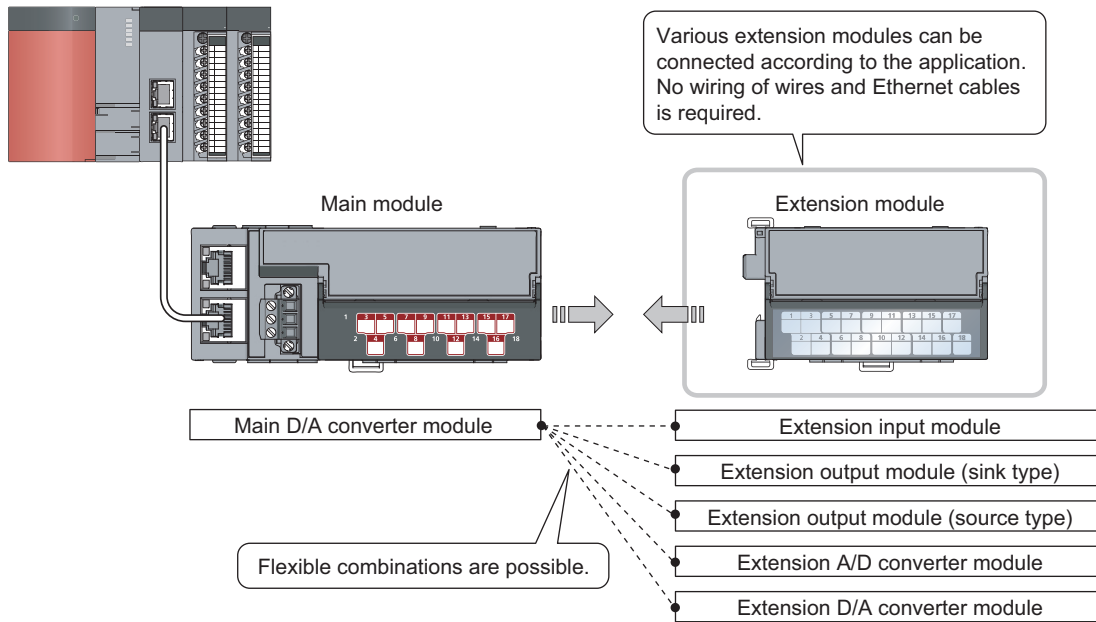

(2) Easy setting of station numbers

Station numbers are set with the rotary switch on the front of the module, where setting and checking the station numbers are easy.

(3) Improved response by high-speed conversion

The high-speed conversion, 100 μ s/channel, has been achieved.

(4) Reliability with high accuracy

The obtained accuracy for the maximum value of analog output value is high: $\pm 0.2\%$ at an ambient temperature of $25 \pm 5^\circ\text{C}$; and $\pm 0.3\%$ at an ambient temperature of 0 to 55°C .

(5) D/A conversion at any desired timing

D/A conversion is performed on a digital value immediately after the input of a trigger output request for each channel.

The combination with the external signal assignment function allows direct input of a trigger output request from the extension input module, which has the following advantages:

- Being free from the effect of the sequence scan and link scan, analog output values can be constantly obtained at a given timing, which leads to the improvement of the reliability.
- Analog output values can be obtained without any program, which leads to a reduction in the cost of creating a program.

(6) Change to any scale

D/A conversion values can be converted to be within any scale, the range of which is determined arbitrarily. According to a digital value to be input, the scale can be changed without any program, resulting in cost reduction.

(7) Error detection and error monitoring

An alert issued for a digital value exceeding the range set in advance allows monitoring abnormality of a digital value and limiting the output of a digital value.

(8) Output without an influence of the sequence scan and link scan

Using the external signal assignment function allows the output of an error status or an alert status from the extension output module in the event of an error or an alert.

This output is free from the influence of the sequence scan and link scan.

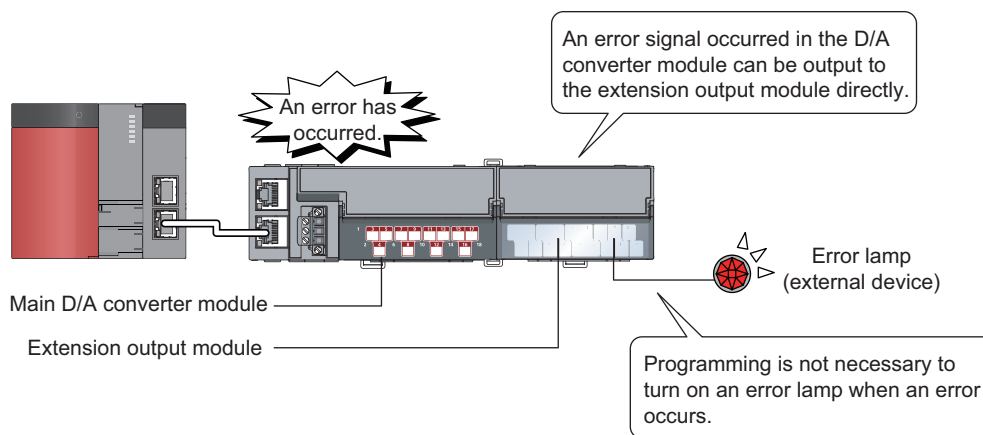
**(9) Support for the CC-Link IE Field Network synchronous communication function**

D/A conversion can be performed with a synchronization period of the master station that supports the CC-Link IE Field Network synchronous communication function.

This enables the D/A converter module to operate at the same timing of other slave stations sharing the same network.

(10) Various installation methods

The module can be installed in six directions using a DIN rail.

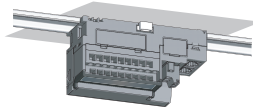

Downward installation

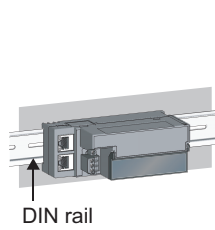

Horizontal installation

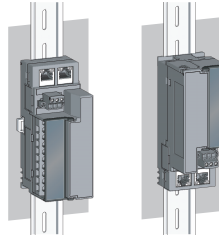

Vertical installation

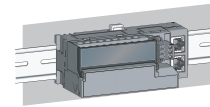

Horizontal installation
(upside down)

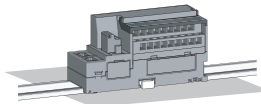

Upward installation

(11) Easy module replacement

The terminal block for module power supply and FG, and the terminal block for analog output signals have a two-piece structure, where the module can be replaced with the wire connected. In addition, the terminal block for analog output signals has a lift-up structure, where the terminal block lifts only by loosening the terminal block mounting screw, enabling it to be removed easily.

(12) Check on the error history

The history of the last 15 errors and occurrence time is stored in the main D/A converter module. Checking the error information of the past helps to identify the cause at the time of a trouble.

(13) Easy settings by CC IE Field configuration of the engineering tool

The CC IE Field configuration of the engineering tool makes it possible to set parameters on its window, thereby reducing the programs. In addition, the setting status and the operating status of modules can be checked easily.

CHAPTER 2 PART NAMES

2.1 Main D/A Converter Module

2

This section describes part names of the main D/A converter module.

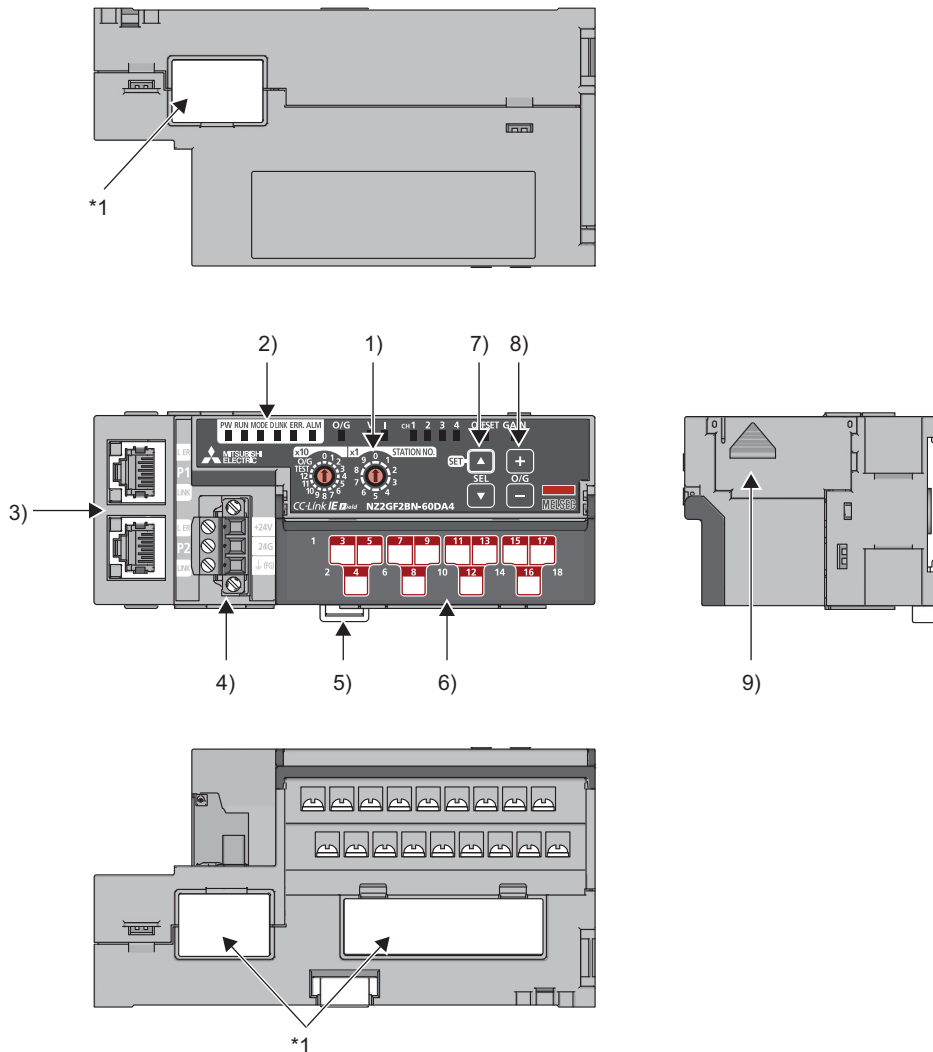

*1 Do not remove this seal because it is used for our maintenance purposes.

No.	Name	Application
1)	Station number setting switch	A rotary switch for the following settings and test: <ul style="list-style-type: none"> • Station Number Setting (☞ Page 50, Section 6.1) • Offset/Gain Setting (☞ Page 83, Section 7.3) • Unit Test (☞ Page 166, Section 11.5) When operating the station number setting switch, use a flathead screwdriver with a tip width of 3.5mm or less.

2.1 Main D/A Converter Module

No.	Name	Application		
2)	PW LED (green)	Indicates the power supply status of the main D/A converter module. • On: Power-on • Off: Power-off		
	RUN LED (green)	Indicates the operating status of the main D/A converter module. • On: Operating normally; Writing data to the non-volatile memory (while in offset/gain setting mode) • Off: Major error occurred or in offset/gain setting mode		
	MODE LED (green)	Indicates the mode of the main D/A converter module. • On: In online mode • Flashing: In unit test mode • Off: In offset/gain setting mode		
	D LINK LED (green)	Indicates the data link status of the main D/A converter module. • On: Data link in operation (cyclic transmission in progress) • Flashing: Data link in operation. (cyclic transmission stopped) • Off: Data link not performed (disconnected)		
	ERR. LED (red)	Indicates the error status of the main D/A converter module. • On: Moderate error or major error occurred • Flashing: Warning issued • Off: Operating normally		
	ALM LED (red)	Indicates the alert status of the main D/A converter module. • On: Alert issued • Flashing: Out-of-range digital value error occurred • Off: Operating normally		
	O/G LED (green)	Indicates the module is in offset/gain setting mode. • On: In offset/gain setting mode • Off: In a mode other than offset/gain setting mode		
	V LED (green), I LED (green)	Indicates the user range of a set target selected in offset/gain setting mode.		
		Setting target	V LED	I LED
		User range setting 1 (-10 to 10V)	On	Off
User range setting 2 (0 to 20mA)	Off	On		
CH1 to CH4 LED (green)	Indicates the channel for the selected setting in the offset/gain setting mode. • On: The channel corresponding to the number being on is the set target. • Off: The channel corresponding to the number being off is not the set target.			
OFFSET LED (green), GAIN LED (green)	Indicates whether the selected setting is offset or gain in the offset/gain setting mode.			
	Set target	OFFSET LED	GAIN LED	
	Offset	On	Off	
Gain	Off	On		
3)	P1	PORT1 connector for the connection to CC-Link IE Field Network (RJ45 connector) Connect an Ethernet cable. (☞ Page 60, Section 6.5) There are no restrictions on the connection order of the cables for the P1 connector and P2 connector.		
	L ER LED (red)	• On: Module received abnormal data, or module performing loopback • Off: Module received normal data, or module not performing loopback		
	LINK LED (green)	• On: Link-up • Off: Link-down		
	P2	PORT2 connector for the connection to CC-Link IE Field Network (RJ45 connector) Connect an Ethernet cable. (☞ Page 60, Section 6.5) There are no restrictions on the connection order of the cables for the P1 connector and P2 connector.		
	L ER LED (red)	(same as the LEDs of the P1 connector)		
LINK LED (green)				
4)	Terminal block for module power and FG	A terminal block for the connection of a module power supply (24VDC) and FG		
5)	DIN rail hook	A hook for mounting a module on a DIN rail		
6)	Terminal cover	Covers for preventing electric shock while the power is on.		
	Terminal block for analog output signals	A two-piece screw terminal block for the connection to an external device		
7)	SET/SEL button	In offset/gain setting mode, select the set target by pressing ▲ button or ▼ button.		
8)	+/- button	In offset/gain setting mode, set up the analog output value by pressing + button or - button.		
9)	Extension connector cover	A cover to protect a connector of an extension module. Do not remove the cover if an extension module is not connected to the connector.		

(1) Module status and LED status

The following table shows how module status and LED status correspond each other.

Module status		Data link status	LED status						
			PW LED	RUN LED	MODE LED	D LINK LED	ERR. LED	ALM LED	O/G LED
Normal mode	Disconnecting	Disconnection	On	On	On	Off	Off	Off	Off
	Link in progress	Data link in operation	On	On	On	On	Off	Off	Off
	Reserved station specification in progress	Cyclic stop	On	On	On	Flashing	Off	Off	Off
	Link stop	Cyclic stop	On	On	On	Flashing	Off	Off	Off
Offset/gain setting mode		—	On	Off	Off	Off	Off	Off	On
Unit test	In progress	—	On	On	Flashing	Off	Off	Off	Off
	Completed successfully	—	On	On	Off	Off	Off	Off	Off
	Completed with an error	—	On	On	Off	Off	On	Off	Off
Communication error		Cyclic stop	On	On	On	Flashing	On	Off	Off
Error	Major error	—	On	Off	*2	*1	On*3	*1	Off
	Moderate error	—	On	On	*2	*1	On	*1	Off
Warning	Minor error	—	On	On	*2	*1	Flashing	*1	Off
Alarm	Alert issued	—	On	On	On	*1	*1	On	Off
	Out-of-range digital value error occurred	—	On	On	On	*1	*1	Flashing	Off

*1 Either On, Flashing, or Off.

*2 Either On or Off.

*3 A failure of the module may not allow the LED to turn on.

2.2 Extension D/A Converter Module

This section describes part names of the extension D/A converter module.

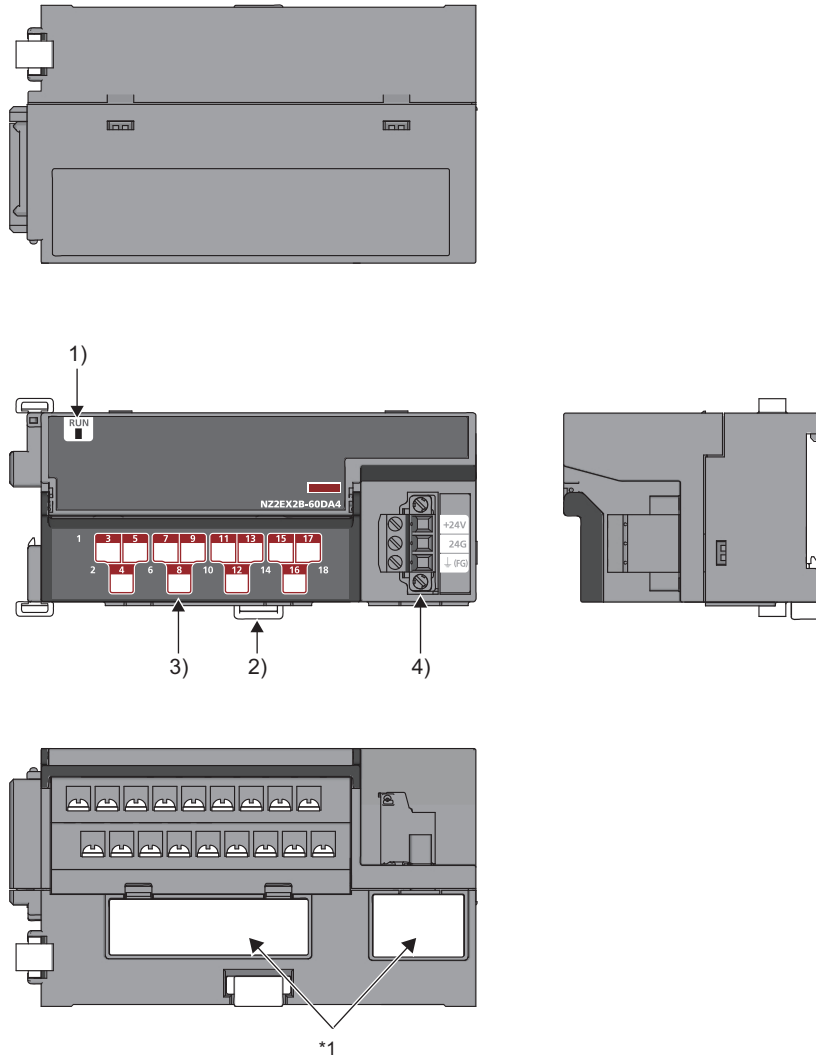

*1 Do not remove this seal because it is used for our maintenance purposes.

No.	Name	Application
1)	RUN LED (green)	Indicates the operating status of the extension D/A converter module. <ul style="list-style-type: none"> • On: Operating normally. • Flashing: External power supply being off • Off: Major error occurred; main analog module being in offset/gain setting mode; or main analog module being in unit test mode
2)	DIN rail hook	A hook for mounting a module on a DIN rail
3)	Terminal cover	A cover for preventing electric shock while the power is on
	Terminal block for analog output signals	A two-piece terminal block for the connection to an external device
4)	Terminal block for external power supply and FG	A terminal block for the connection of an external power supply (24VDC) and FG

CHAPTER 3 SPECIFICATIONS

This chapter describes the specifications of the D/A converter module.

3.1 General Specifications

Item	Specifications					
Operating ambient temperature	0 to 55°C					
Storage ambient temperature	-25 to 75°C					
Operating ambient humidity	5 to 95%RH, non-condensing					
Storage ambient humidity						
Vibration resistance	Compliant with JIS B 3502 and IEC 61131-2	Under intermittent vibration	Frequency	Constant acceleration	Half amplitude	Number of sweeps
			5 to 8.4Hz	—	3.5mm	
		Under continuous vibration	8.4 to 150Hz	9.8m/s ²	—	10 times each in X, Y, and Z directions
			5 to 8.4Hz	—	1.75mm	—
8.4 to 150Hz	4.9m/s ²	—	—	—		
Shock resistance	Compliant with JIS B 3502 and IEC 61131-2 (147m/s ² , 3 times each in X, Y, and Z directions)					
Operating atmosphere	No corrosive gases					
Operating altitude*1	0 to 2000m					
Installation location	Inside a control panel*2					
Overvoltage category*3	II or less					
Pollution degree*4	2 or less					
Equipment class	Class I					

*1 Do not use or store the D/A converter module under pressure higher than the atmospheric pressure at an elevation of 0 meters. Doing so may cause malfunction. When using the D/A converter module under pressure, please consult your local Mitsubishi representative.

*2 If the environment satisfies the operating ambient temperature, operating ambient humidity and other conditions, the module can be used even outside the control panel.

*3 This indicates the assumption that the equipment is connected to which type of power distribution system, from the public electrical power distribution network down to machinery within premises. Category II applies to equipment for which electrical power is supplied from fixed facilities. The surge voltage withstand level for the equipment with up to the rated voltage of 300V is 2500V.

*4 This index indicates the degree to which conductive material is generated in terms of the environment in which the equipment is used. In pollution degree 2, only non-conductive pollution occurs. A temporary conductivity caused by condensation must be expected occasionally.

Point

For compliance with the EMC Directive, refer to "EMC and Low Voltage Directives" in this manual. (☞ Page 210, Appendix 7)

3.2 Performance Specifications

3.2.1 Main D/A converter module

Item		Description			
Station type		Remote device station			
Number of analog output points		4 points (4 channels)/module			
Digital input		16-bit signed binary (-16384 to 16383, -288 to 12287, -12288 to 12287)			
Analog output	Voltage	-10 to 10VDC (external load resistance value: 1kΩ to 1MΩ)			
	Current	0 to 20mADC (external load resistance value: 0Ω to 600Ω)			
I/O characteristics, maximum resolution*1	Voltage	Output range	Output range	Digital value	Maximum resolution
		-10 to 10V	-16000 to 16000		0.625mV
		0 to 5V	0 to 12000		0.416mV
		1 to 5V	0 to 12000		0.333mV
	User range setting 1 (-10 to 10V)	-12000 to 12000		0.333mV	
	Current	0 to 20mA	0 to 12000		1.66μA
		4 to 20mA			1.33μA
User range setting 2 (0 to 20mA)		0.95μA			
Conversion accuracy*2	Ambient temperature (25±5°C)	±0.2%			
	Ambient temperature (0 to 55°C)	±0.3%			
Conversion speed*4		100μs/channel			
Output short circuit protection		Protected			
Absolute maximum output		Voltage: ±15V, Current: ±21mA			
Isolation method		Between communication system terminal and all analog output terminals: Photocoupler isolation Between power supply system terminal and all analog output terminals: Transformer isolation Between output channels: Non-isolation			
Withstand voltage		Between all power supply and communication system terminals and all analog output terminals 500VAC for 1 minute			
Noise immunity		Noise voltage 500Vp-p, noise width 1μs, noise frequency 25 to 60Hz (noise simulator condition)			
External interface	Communication part	RJ45 connector			
	Module power supply part	Terminal block for module power supply and FG Tightening torque range for terminal screw (M2.5 screw): 0.5 to 0.6N·m			
	I/O part	18-point two-piece terminal block (M3 screw) Tightening torque range for terminal screw (M3 screw × 5.2): 0.43 to 0.57N·m			
Applicable DIN rail		TH35-7.5Fe, TH35-7.5Al (compliant with IEC 60715)			
Applicable wire size	For power supply	Core: 0.5 to 1.5mm ² (20 to 16 AWG)			
	For I/O	Core: 0.3 to 2.0mm ² (22 to 14 AWG)			

Item	Description
Applicable solderless terminal	Terminal block for module power supply and FG ^{*3} TE 0.5-10 (NICHIFU Co., Ltd.) [Applicable wire size: 0.5mm ²] TE 0.75-10 (NICHIFU Co., Ltd.) [Applicable wire size: 0.75mm ²] TE 1.0-10 (NICHIFU Co., Ltd.) [Applicable wire size: 0.9 to 1.0mm ²] TE 1.5-10 (NICHIFU Co., Ltd.) [Applicable wire size: 1.25 to 1.5mm ²] AI 0.5-10WH (Phoenix Contact Co., Ltd.) [Applicable wire size: 0.5mm ²] AI 0.75-10GY (Phoenix Contact Co., Ltd.) [Applicable wire size: 0.75mm ²] AI 1-10RD (Phoenix Contact Co., Ltd.) [Applicable wire size: 1.0mm ²] AI 1.5-10BK (Phoenix Contact Co., Ltd.) [Applicable wire size: 1.5mm ²]
	Terminal block for analog output signals RAV1.25-3 (compliant with JIS C 2805) [Applicable wire size: 0.3 to 1.25mm ²] V2-MS3 (JST Mfg. Co., Ltd) [Applicable wire size: 1.25 to 2.0mm ²] RAP2-3SL (Nippon Tanshi Co., Ltd.) [Applicable wire size: 1.25 to 2.0mm ²] TGV2-3N (NICHIFU Co., Ltd.) [Applicable wire size: 1.25 to 2.0mm ²]
Cyclic transmission	RX/RV points 32 points + 16 points × Number of extension modules
	RWw/RWw points 16 points + Points of each extension module
Communication cable	An Ethernet cable that meets the 1000BASE-T standard: Category 5e or higher (double shielded, STP), straight cable
Applicability of extension module	Connectable (Max. one module)
External power supply	24VDC (20.4 to 28.8VDC) Inrush current: 39.0A, 1ms or lower Current consumption: 300mA
Weight	0.29kg

- *1 For details on the I/O conversion characteristics, refer to the following:
- I/O Conversion Characteristics of D/A Conversion (☞ Page 205, Appendix 4)
- *2 Except for the conditions under noise influence.
- *3 Do not connect two or more wires to the terminal.
- *4 The conversion period varies depending on whether an extension analog module is connected or not. For details, refer to the following:
- Conversion Speed and Conversion Period (☞ Page 89, Section 8.5)

3.2.2 Extension D/A converter module

Item		Description				
Number of analog output points		4 points (4 channels)/module				
Digital input		16-bit signed binary (-16384 to 16383, -288 to 12287, -12288 to 12287)				
Analog output	Voltage	-10 to 10VDC (external load resistance value: 1kΩ to 1MΩ)				
	Current	0 to 20mADC (external load resistance value: 0Ω to 600Ω)				
I/O characteristics, maximum resolution*1		Output	Output range	Digital value	Maximum resolution	
		Voltage	-10 to 10V		-16000 to 16000	0.625mV
			0 to 5V		0 to 12000	0.416mV
			1 to 5V			0.333mV
		Current	0 to 20mA		0 to 12000	1.66μA
			4 to 20mA			1.33μA
Conversion accuracy*2	Ambient temperature (25±5°C)	±0.2%				
	Ambient temperature (0 to 55°C)	±0.3%				
Conversion speed*4		100μs/channel				
Output short circuit protection		Protected				
Absolute maximum output		Voltage: ±15V, Current: ±21mA				
Isolation method		Between communication system terminal and all analog output terminals: Photocoupler isolation Between power supply system terminal and all analog output terminals: Transformer insulation Between output channels: Non-isolation				
Withstand voltage		Between all power supply and communication system terminals and all analog output terminals 500VAC for 1 minute				
Noise immunity		Noise voltage 500Vp-p, noise width 1μs, noise frequency 25 to 60Hz (noise simulator condition)				
External interface	External power supply part	Terminal block for external power supply and FG Tightening torque range for terminal screw (M2.5 screw): 0.5 to 0.6N·m				
	I/O part	18-point two-piece terminal block (M3 screw) Tightening torque range for terminal screw (M3 screw × 5.2): 0.43 to 0.57N·m				
Applicable DIN rail		TH35-7.5Fe, TH35-7.5Al (compliant with IEC 60715)				
Applicable wire size	For power supply	Core: 0.5 to 1.5mm ² (20 to 16 AWG)				
	For I/O	Core: 0.3 to 2.0mm ² (22 to 14 AWG)				
Applicable solderless terminal	Terminal block for external power supply and FG*3	TE 0.5-10 (NICHIFU Co., Ltd.) [Applicable wire size: 0.5mm ²] TE 0.75-10 (NICHIFU Co., Ltd.) [Applicable wire size: 0.75mm ²] TE 1.0-10 (NICHIFU Co., Ltd.) [Applicable wire size: 0.9 to 1.0mm ²] TE 1.5-10 (NICHIFU Co., Ltd.) [Applicable wire size: 1.25 to 1.5mm ²] AI 0.5-10WH (Phoenix Contact Co., Ltd.) [Applicable wire size: 0.5mm ²] AI 0.75-10GY (Phoenix Contact Co., Ltd.) [Applicable wire size: 0.75mm ²] AI 1-10RD (Phoenix Contact Co., Ltd.) [Applicable wire size: 1.0mm ²] AI 1.5-10BK (Phoenix Contact Co., Ltd.) [Applicable wire size: 1.5mm ²]				
	Terminal block for analog output signals	RAV1.25-3 (compliant with JIS C 2805) [Applicable wire size: 0.3 to 1.25mm ²] V2-MS3 (JST Mfg. Co., Ltd.) [Applicable wire size: 1.25 to 2.0mm ²] RAP2-3SL (Nippon Tanshi Co., Ltd.) [Applicable wire size: 1.25 to 2.0mm ²] TGV2-3N (NICHIFU Co., Ltd.) [Applicable wire size: 1.25 to 2.0mm ²]				
Cyclic transmission	RX/Ry points	16 points				
	RWr/RWw points	16 points				
Module power supply (supplied from the main module)	Voltage	24VDC (20.4 to 28.8VDC)				
	Current	95mA				
External power supply		24VDC (20.4 to 28.8VDC) Inrush current: 27.5A, 1ms or lower Current consumption: 135mA				

Item	Description
Weight	0.23kg
*1	For details on the I/O conversion characteristic, refer to the following:
*2	• I/O Conversion Characteristics of D/A Conversion (☞ Page 205, Appendix 4)
*3	Except for the conditions under noise influence.
*4	Do not connect two or more wires to the terminal.
*4	For the conversion period with the extension D/A converter module connected, refer to the following:
	• Conversion Speed and Conversion Period (☞ Page 89, Section 8.5)

3.3 How to Calculate Current Consumption

The total current consumption of the modules is calculated by summing the module power supply current in the main D/A converter module and extension module.

For the value of the module power supply current, refer to the specifications of each module.

- Performance specifications of main D/A converter module (☞ Page 24, Section 3.2.1)
- Performance specifications of extension D/A converter module (☞ Page 26, Section 3.2.2)
- Performance Specifications of extension I/O module (📖 CC-Link IE Field Network Remote I/O Module User's Manual)
- Performance specifications of extension A/D converter module (📖 CC-Link IE Field Network Analog-Digital Converter Module User's Manual)

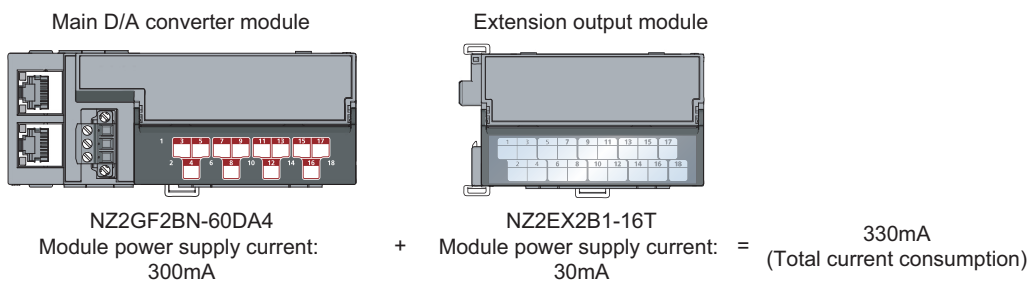

The value of the module power supply current in the extension module described in the specifications is the value of the module power supply current supplied from the main D/A converter module.



3.4 Function List

○: Available, ×: Not available

Item	Description	Available or not		Reference
		Main *1	Extension *1	
D/A conversion enable/disable function	Allows D/A conversion to be enabled or disabled for each channel. Disabling the D/A conversion for unused channels reduces the conversion cycles.	○	○	Page 88, Section 8.3
D/A output enable/disable function	Allows the selection of whether to output the D/A conversion value or the offset value for each channel. Whether the output is enabled or disabled, the conversion period is constant.	○	○	Page 88, Section 8.4
Range switching function	Allows the output range to be selected for each channel from the following: • Factory default range (4 to 20mA, 0 to 20mA, 1 to 5V, 0 to 5V, -10 to 10V) • User range (user range setting 1, user range setting 2)	○	○*2	Page 92, Section 8.6
Offset/gain setting function	Allows the correction of errors in analog output values.	○	×	Page 83, Section 7.3
Analog output HOLD/CLEAR function	Allows the selection of whether to hold or clear the analog value output when the CPU module is in the following operating status: RUN, STOP, or a stop error.	○	○	Page 93, Section 8.7
Cyclic data update watch function	Monitors the update intervals of cyclic data. For the cyclic transmission stop lasting longer than the specified monitoring time, whether to hold or clear the last output value can be selected.	○	○	Page 95, Section 8.8
Scaling function	Performs scale conversion on a digital value within the range of the scaling upper limit value and the scaling lower limit value, both of which are set at desired values. This reduces the time and effort to create a program of the scale conversion.	○	○	Page 96, Section 8.9
Shift function	Provides analog output, adding the set shift value to a digital value. This function facilitates fine adjustment at the system start-up.	○	○	Page 101, Section 8.10
Digital value range check function	Outputs an error when a digital value is out of the digital input range of the output range setting.	○	○	Page 105, Section 8.11
Alert output function	Outputs an alert when a digital value falls within the alert output range set in advance.	○	○	Page 107, Section 8.12
Trigger output function	Provides D/A conversion in accordance with the input of Trigger output request.	○	○	Page 110, Section 8.13
	Trigger output request that is input to the extension input module via an external device also allows D/A conversion.	○	×	
CC-Link IE Field Network synchronous communication function	Performs D/A conversion with a synchronization period of the master station that supports the CC-Link IE Field Network synchronous communication function. This makes it possible to synchronize the operation with other slave stations sharing the same network.	○	○	Page 120, Section 8.14
Error notification function	Notifies an error to the master station by the remote input signal if a moderate error or a major error occurs in the D/A converter module.	○	○	Page 126, Section 8.15
Functions with an extension I/O module connected	The main D/A converter module permits the connection of one extension I/O module. • With an extension input module connected, remote output signals of the main D/A converter module can be assigned to remote input signals of the extension input module connected. • With an extension output module connected, remote input signals of the main D/A converter module can be assigned to remote output signals of the extension output module connected. Functions unique to an extension I/O module can also be used.	○	×	Page 129, Section 8.16.1

Item	Description	Available or not		Reference
		Main ^{*1}	Extension ^{*1}	
Functions with an extension analog module connected	The main D/A converter module permits the connection of one extension D/A converter module. With the extension D/A converter module connected, D/A conversion processing of up to eight channels is possible.	○	○	Page 133, Section 8.16.2
	The main D/A converter module permits the connection of one extension A/D converter module. With the extension A/D converter module connected, A/D conversion processing of four channels and D/A conversion processing of four channels is possible.	○	×	Page 134, Section 8.16.3
CC-Link IE Field Network diagnostic function	Allows the presence or absence of a network error to be checked by accessing the engineering tool connected to the CPU module.	○	×	Page 135, Section 8.17
Automatic detection of connected device	Automatically generates "List of devices" and "Device map area" of the device supporting iQSS connected to the master module with an engineering tool.	○	×	 iQ Sensor Solution Reference Manual
Sensor parameter read/write	Reads or writes parameters of the device supporting iQSS.	○	×	 iQ Sensor Solution Reference Manual
Data backup/restoration	Backs up the slave module information in the SD memory card. Also restores the slave module information backed up in the SD memory card.	○	×	 iQ Sensor Solution Reference Manual

*1 "Main" and "Extension" indicate the following modules, respectively:

Main: Main D/A converter module

Extension: Extension D/A converter module

*2 The extension D/A converter module does not support user range.

3.5 List of Remote I/O Signals

This section lists I/O signals for a master/local module.

The device number assignment shown assumes that the remote I/O signals of the main module are assigned to RX0 to RX1F and RY0 to RY1F.

Remote input (RX) indicates the input signal from D/A converter module to master/local module.

Remote output (RY) indicates the output signal from master/local module to D/A converter module.

The remote I/O signals of the main D/A converter module and extension module are assigned as shown below.

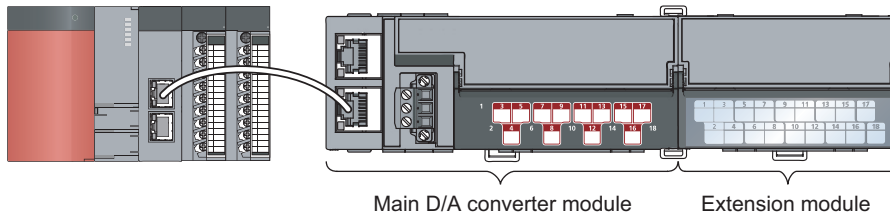

Module	Remote input (RX)	Remote output (RY)
Main D/A converter module	RX0 to RX1F	RY0 to RY1F
Extension module	RX20 to RX2F	RY20 to RY2F

For details on the remote I/O signals, refer to the following:

- Page 170, Appendix 1

3.5.1 Main D/A converter module



Module type	Remote input		Remote output	
	Signal direction: Main D/A converter module → Master/local module		Signal direction: Master/local module → Main D/A converter module	
	Device No.	Description	Device No.	Description
Main D/A converter module	RX0	Use prohibited	RY0	Use prohibited
	RX1	Use prohibited	RY1	Use prohibited
	RX2	Use prohibited	RY2	Use prohibited
	RX3	Use prohibited	RY3	Use prohibited
	RX4	Use prohibited	RY4	Use prohibited
	RX5	Use prohibited	RY5	Use prohibited
	RX6	Use prohibited	RY6	Use prohibited
	RX7	Warning flag	RY7	Use prohibited
	RX8	Use prohibited	RY8	Use prohibited
	RX9	Initial data setting completed flag	RY9	Initial data setting request flag
	RXA	Error flag	RYA	Error clear request flag
	RXB	Remote READY	RYB	Use prohibited
	RXC	Use prohibited	RYC	Use prohibited
	RXD	Use prohibited	RYD	Use prohibited
	RXE	Use prohibited	RYE	Use prohibited
	RXF	Use prohibited	RYF	Use prohibited
	RX10	Use prohibited	RY10	CH1 Output enable/disable flag
	RX11	Use prohibited	RY11	CH2 Output enable/disable flag
	RX12	Use prohibited	RY12	CH3 Output enable/disable flag
	RX13	Use prohibited	RY13	CH4 Output enable/disable flag
	RX14	Use prohibited	RY14	Use prohibited
	RX15	Use prohibited	RY15	Use prohibited
	RX16	Use prohibited	RY16	Use prohibited
	RX17	Use prohibited	RY17	Use prohibited
	RX18	Use prohibited	RY18	Use prohibited
	RX19	Trigger output completed flag	RY19	Trigger output request
	RX1A	Use prohibited	RY1A	Trigger output completed clear request
	RX1B	Use prohibited	RY1B	Use prohibited
	RX1C	Use prohibited	RY1C	Use prohibited
	RX1D	Use prohibited	RY1D	Use prohibited
RX1E	Alert output signal	RY1E	Alert output clear request flag	
RX1F	External power supply monitor status flag (for extension output module)	RY1F	External power supply monitor request flag (for extension output module)	



Do not use any "Use prohibited" remote I/O signals. Doing so may result in an accident due to an incorrect output or malfunction.

(1) Remote I/O signals of extension modules

The remote I/O signals differ depending on the model of extension module.

- For the extension D/A converter module, refer to  Page 33, Section 3.5.2.
- For the extension A/D converter module, refer to  CC-Link IE Field Network Analog-Digital Converter Module User's Manual.
- For the extension I/O module, refer to  CC-Link IE Field Network Remote I/O Module User's Manual.

3.5.2 Extension D/A converter module

Module type	Remote input		Remote output	
	Signal direction: Extension D/A converter module→Master/local module		Signal direction: Master/local module→Extension D/A converter module	
	Device No.	Description	Device No.	Description
Extension D/A converter module	RX20	Use prohibited	RY20	CH1 Output enable/disable flag
	RX21	Use prohibited	RY21	CH2 Output enable/disable flag
	RX22	Use prohibited	RY22	CH3 Output enable/disable flag
	RX23	Use prohibited	RY23	CH4 Output enable/disable flag
	RX24	Use prohibited	RY24	Use prohibited
	RX25	Use prohibited	RY25	Use prohibited
	RX26	Use prohibited	RY26	Use prohibited
	RX27	Use prohibited	RY27	Use prohibited
	RX28	Use prohibited	RY28	Use prohibited
	RX29	Trigger output completed flag	RY29	Trigger output request
	RX2A	Use prohibited	RY2A	Trigger output completed clear request
	RX2B	Use prohibited	RY2B	Use prohibited
	RX2C	Use prohibited	RY2C	Use prohibited
	RX2D	Use prohibited	RY2D	Use prohibited
	RX2E	Alert output signal	RY2E	Alert output clear request flag
	RX2F	External power supply READY flag	RY2F	Use prohibited

Point

Do not use any "Use prohibited" remote I/O signals. Doing so may result in an accident due to an incorrect output or malfunction.

3.6 List of Remote Registers

This section lists remote registers for a master/local module.

The remote register assignment shown assumes that the remote registers of the main module are assigned to RWr0 to RWrF and RWw0 to RWwF.

Remote register (RWr) is the information input from D/A converter module to master/local module.

Remote register (RWw) is the information output from master/local module to D/A converter module.

The remote registers of the main D/A converter module and extension module are assigned as shown below.

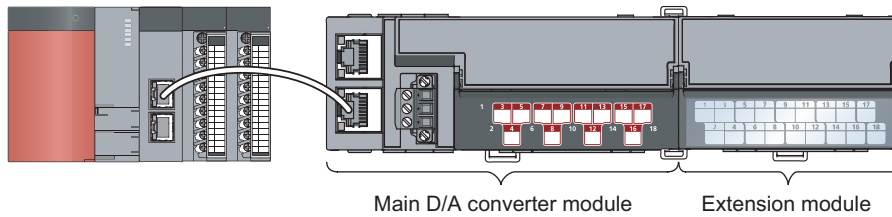

Module	Remote register (RWr)	Remote register (RWw)
Main D/A converter module	RWr0 to RWrF	RWw0 to RWwF
Extension module	(depends on the type of the extension module)	

For details on the remote register, refer to the following:

-  Page 180, Appendix 2

3.6.1 Main D/A converter module

Module type	Remote register (RWr)		Remote register (RWw)	
	Signal direction: Main D/A converter module → Master/local module		Signal direction: Master/local module → Main D/A converter module	
	Device No.	Description	Device No.	Description
Main D/A converter module	RWr0	Latest error code	RWw0	Use prohibited
	RWr1	Latest warning code	RWw1	Use prohibited
	RWr2	CH1 Set value check code	RWw2	CH1 Digital value
	RWr3	CH2 Set value check code	RWw3	CH2 Digital value
	RWr4	CH3 Set value check code	RWw4	CH3 Digital value
	RWr5	CH4 Set value check code	RWw5	CH4 Digital value
	RWr6	Use prohibited	RWw6	CH1 Shifting set value
	RWr7	Use prohibited	RWw7	CH2 Shifting set value
	RWr8	Use prohibited	RWw8	CH3 Shifting set value
	RWr9	Use prohibited	RWw9	CH4 Shifting set value
	RWrA	Alert output flag	RWwA	Use prohibited
	RWrB	Use prohibited	RWwB	Use prohibited
	RWrC	Use prohibited	RWwC	Use prohibited
	RWrD	Use prohibited	RWwD	Use prohibited
	RWrE	Use prohibited	RWwE	Use prohibited
	RWrF ^{*1}	Use prohibited	RWwF ^{*1}	Use prohibited



*1 The registers RWrF and RWwF are used by the system in synchronous communication mode.

Point

Do not read/write data from/to any "Use prohibited" remote registers. Doing so may result in an accident due to an incorrect output or malfunction.

(1) Remote registers of extension analog modules

The remote registers differ depending on the model of extension analog module.

- For the extension D/A converter module, refer to  Page 36, Section 3.6.2.
- For the extension A/D converter module, refer to  CC-Link IE Field Network Analog-Digital Converter Module User's Manual.

3.6.2 Extension D/A converter module

Module type	Remote register (RWr)		Remote register (RWw)	
	Signal direction: Extension D/A converter module→Master/local module		Signal direction: Master/local module→Extension D/A converter module	
	Device No.	Description	Device No.	Description
Extension D/A converter module	RWr10	Use prohibited	RWw10	Use prohibited
	RWr11	Use prohibited	RWw11	Use prohibited
	RWr12	CH1 Set value check code	RWw12	CH1 Digital value
	RWr13	CH2 Set value check code	RWw13	CH2 Digital value
	RWr14	CH3 Set value check code	RWw14	CH3 Digital value
	RWr15	CH4 Set value check code	RWw15	CH4 Digital value
	RWr16	Use prohibited	RWw16	CH1 Shifting set value
	RWr17	Use prohibited	RWw17	CH2 Shifting set value
	RWr18	Use prohibited	RWw18	CH3 Shifting set value
	RWr19	Use prohibited	RWw19	CH4 Shifting set value
	RWr1A	Alert output flag	RWw1A	Use prohibited
	RWr1B	Use prohibited	RWw1B	Use prohibited
	RWr1C	Use prohibited	RWw1C	Use prohibited
	RWr1D	Use prohibited	RWw1D	Use prohibited
	RWr1E	Use prohibited	RWw1E	Use prohibited
	RWr1F	Use prohibited	RWw1F	Use prohibited

Point

Do not read/write data from/to any "Use prohibited" remote registers. Doing so may result in an accident due to an incorrect output or malfunction.

3.7 List of Remote Buffer Memory Areas

This section lists the remote buffer memory areas of the D/A converter module.

The remote buffer memory areas of the main module and extension module are assigned as shown below.

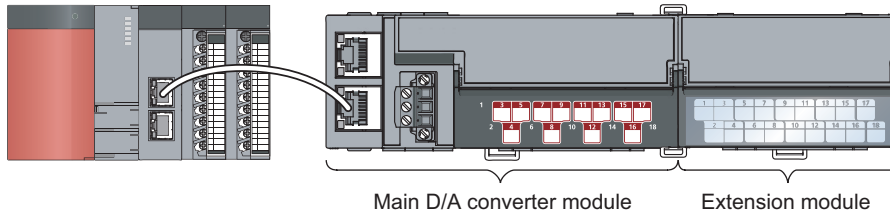

Ex. How the individual areas of remote buffer memory are shown in the manual

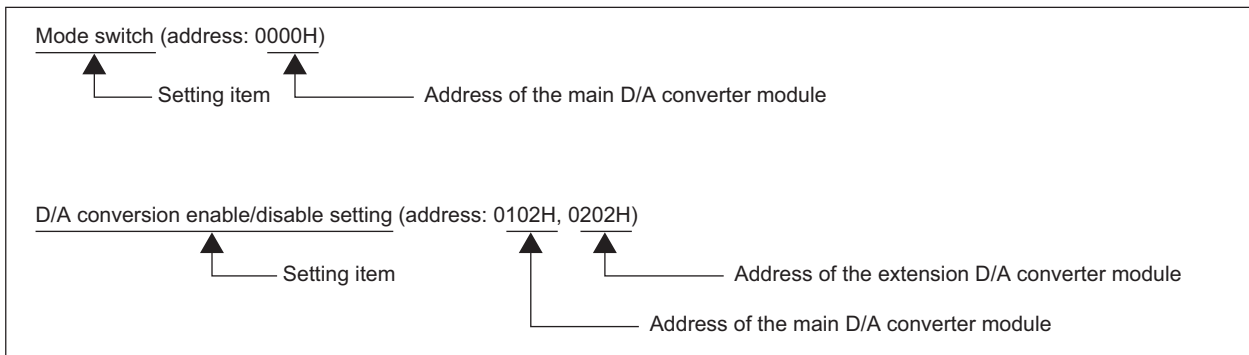

For details on the remote buffer memory for the D/A converter module, refer to the following:

- Page 185, Appendix 3

For details on the remote buffer memory of the connected extension module, refer to the following:

- User's manual for the connected extension module

○: Access permitted, ×: Access not permitted

Remote buffer memory address		Area	Target	Access method		
Decimal	Hexadecimal			CC IE Field configuration of the engineering tool	REMFR instruction, REMTO instruction ^{*1}	
0 to 255	0000H to 00FFH	Parameter area	Station-based parameter data	○ ^{*2}	○	
256 to 511	0100H to 01FFH		Module-based parameter data			Main module
512 to 767	0200H to 02FFH					Extension module 1
768 to 1279	0300H to 04FFH					System area
1280 to 1535	0500H to 05FFH	Monitor area	Station-based monitor data	×	○	
1536 to 1791	0600H to 06FFH		Module-based monitor data			Main module
1792 to 2047	0700H to 07FFH					Extension module 1
2048 to 2559	0800H to 09FFH					System area
2560 to 4095	0A00H to 0FFFH	Error history area	Station-based error history data	○ ^{*2}	○	
4096 to 4351	1000H to 10FFH	Module control data area	Station-based control data	×	○	
4352 to 4607	1100H to 11FFH		Module-based control data			Main module
4608 to 4863	1200H to 12FFH					Extension module 1
4864 to 5375	1300H to 14FFH					System area

- *1 For the REMFR and REMTO instructions, refer to the following:
- 📖 User's manual for the master/local module used
- *2 For the access method, refer to the following:
- Parameter area (📖 Page 69, Section 7.1)
 - Error history area (📖 Page 150, Section 11.1)

Point 

Do not access any system area using the REMFR or REMTO instruction. Doing so may cause malfunction.

3.7.1 Main D/A converter module

(1) Parameter area (address: 0000H to 04FFH)

For the parameter area, parameters can be set by means of the CC IE Field configuration of the engineering tool, or the REMTO instruction.

The parameters in the parameter area are backed up to the non-volatile memory.

The parameters backed up to the non-volatile memory are read out to the parameter area when the module power supply is turned off and on or the module is reset by remote reset.

For the parameters written from the parameter settings of the CC IE Field configuration of the engineering tool, the write to the non-volatile memory is also completed at the same time. For the parameters written using the REMTO instruction, the timing of the write to the non-volatile memory is at the time of turning on Initial data setting request flag (RY9) from off. At this time, even an invalid parameter is written to the non-volatile memory as well. With an invalid parameter written, turning off and on the power supply causes the invalid parameter to be read from the non-volatile memory, resulting in the error code being stored into Latest error code (RWr0). Take corrective action with reference to the error code list. (☞ Page 154, Section 11.2)

Type	Address		Description	Default value ^{*1}	Read/Write ^{*2}	Necessity of RY9 ^{*3}
	Decimal	Hexadecimal				
Station-based parameter data	0	0000H	Mode switch	0009H	R/W	○
	1	0001H	System area	—	—	—
	2	0002H	Trigger output signal assignment (for external signal assignment function)	FFFFH	R/W	○
	3	0003H	System area	—	—	—
	4	0004H	Alert output signal assignment (for external signal assignment function)	FFFFH	R/W	○
	5	0005H	Error flag assignment (for external signal assignment function)	FFFFH	R/W	○
	6	0006H	Warning flag assignment (for external signal assignment function)	FFFFH	R/W	○
	7	0007H	Cyclic data update watch time setting	0000H	R/W	○
	8 to 15	0008H to 000FH	System area	—	—	—
	16	0010H	Input response time setting	0005H	R/W	○
	17	0011H	Digital output HOLD/CLEAR setting	0000H	R/W	○
	18 to 255	0012H to 00FFH	System area	—	—	—
Main module Module-based parameter data	256, 257	0100H, 0101H	System area	—	—	—
	258	0102H	D/A conversion enable/disable setting	000FH	R/W	○
	259	0103H	Range setting	0000H	R/W	○
	260	0104H	Analog output HOLD/CLEAR setting	0000H	R/W	○
	261	0105H	Alert output setting	000FH	R/W	○
	262	0106H	CH1 Alert output upper limit value	0000H	R/W	○
	263	0107H	CH1 Alert output lower limit value	0000H	R/W	○
	264	0108H	CH2 Alert output upper limit value	0000H	R/W	○
	265	0109H	CH2 Alert output lower limit value	0000H	R/W	○
	266	010AH	CH3 Alert output upper limit value	0000H	R/W	○
	267	010BH	CH3 Alert output lower limit value	0000H	R/W	○
	268	010CH	CH4 Alert output upper limit value	0000H	R/W	○
269	010DH	CH4 Alert output lower limit value	0000H	R/W	○	

Type	Address		Description	Default value ^{*1}	Read/Write ^{*2}	Necessity of RY9 ^{*3}
	Decimal	Hexadecimal				
Main module Module-based parameter data	270	010EH	Scaling enable/disable setting	000FH	R/W	○
	271	010FH	CH1 Scaling lower limit value	0	R/W	○
	272	0110H	CH1 Scaling upper limit value	0	R/W	○
	273	0111H	CH2 Scaling lower limit value	0	R/W	○
	274	0112H	CH2 Scaling upper limit value	0	R/W	○
	275	0113H	CH3 Scaling lower limit value	0	R/W	○
	276	0114H	CH3 Scaling upper limit value	0	R/W	○
	277	0115H	CH4 Scaling lower limit value	0	R/W	○
	278	0116H	CH4 Scaling upper limit value	0	R/W	○
	279 to 511	0117H to 01FFH	System area	—	—	○
Extension module 1 Module-based parameter data	512 to 767	0200H to 02FFH	The remote buffer memory areas of the connected extension module are assigned.	—	—	—
—	768 to 1279	0300H to 04FFH	System area	—	—	—



*1 This value is the value of factory default or the value of initialization by Parameter area initialization command (address: 1002H).

*2 This shows whether reading/writing data from/to a program is possible.
R: Readable
W: Writable

*3 This shows the items enabled by tuning on and off Initial data setting request flag (RY9).

(a) Parameter area of extension modules

The remote buffer memory areas differ depending on the model of extension module.

- For the extension D/A converter module, refer to  Page 43, Section 3.7.2 (1).
- For the extension A/D converter module, refer to  CC-Link IE Field Network Analog-Digital Converter Module User's Manual.
- For the extension I/O module, refer to  CC-Link IE Field Network Remote I/O Module User's Manual.

(2) Monitor area (address: 0500H to 09FFH)



Type	Address		Description	Default value ^{*1}	Read/Write ^{*2}
	Decimal	Hexadecimal			
Station-based monitor data	1280 to 1535	0500H to 05FFH	System area	—	—
Main module Module-based monitor data	1536 to 1791	0600H to 06FFH	System area	—	—
Extension module 1 Module-based monitor data	1792 to 2047	0700H to 07FFH	The remote buffer memory areas of the connected extension module are assigned.	—	—
—	2048 to 2559	0800H to 09FFH	System area	—	—

*1 Value at the time of turning off and on the module power supply or at the time of remote reset.

*2 This shows whether reading/writing data from/to a program is possible.
R: Readable
W: Writable

(a) Monitor area of extension modules

The remote buffer memory areas differ depending on the model of extension module.

- For the extension D/A converter module, refer to  Page 43, Section 3.7.2 (2).
- For the extension A/D converter module, refer to  CC-Link IE Field Network Analog-Digital Converter Module User's Manual.
- For the extension I/O module, refer to  CC-Link IE Field Network Remote I/O Module User's Manual.

(3) Error history area (address: 0A00H to 0FFFH)

Type	Address		Description	Default value* ¹	Read/Write* ²	
	Decimal	Hexadecimal				
Station-based error history data	2560	0A00H	Error history data 1	Error code	0000H	R
	2561	0A01H		Order of generation	0000H	R
	2562	0A02H		[Error time] First two digits of the year/Last two digits of the year	0000H	R
	2563	0A03H		[Error time] Month/Day	0000H	R
	2564	0A04H		[Error time] Hour/Minute	0000H	R
	2565	0A05H		[Error time] Second/00H (Fixed)	0000H	R
	2566	0A06H		CH1 Digital value	0000H	R
	2567	0A07H		CH2 Digital value	0000H	R
	2568	0A08H		CH3 Digital value	0000H	R
	2569	0A09H		CH4 Digital value	0000H	R
	2570 to 2575	0A0AH to 0A0FH		System area	—	—
	2576 to 2591	0A10H to 0A1FH	Error history data 2	Same as Error history data 1.		
	2592 to 2607	0A20H to 0A2FH	Error history data 3	Same as Error history data 1.		
	2608 to 2623	0A30H to 0A3FH	Error history data 4	Same as Error history data 1.		
	2624 to 2639	0A40H to 0A4FH	Error history data 5	Same as Error history data 1.		
	2640 to 2655	0A50H to 0A5FH	Error history data 6	Same as Error history data 1.		
	2656 to 2671	0A60H to 0A6FH	Error history data 7	Same as Error history data 1.		
	2672 to 2687	0A70H to 0A7FH	Error history data 8	Same as Error history data 1.		
	2688 to 2703	0A80H to 0A8FH	Error history data 9	Same as Error history data 1.		
	2704 to 2719	0A90H to 0A9FH	Error history data 10	Same as Error history data 1.		
2720 to 2735	0AA0H to 0AAFH	Error history data 11	Same as Error history data 1.			
Station-based error history data	2736 to 2751	0AB0H to 0ABFH	Error history data 12	Same as Error history data 1.		
	2752 to 2767	0AC0H to 0ACFH	Error history data 13	Same as Error history data 1.		
	2768 to 2783	0AD0H to 0ADFH	Error history data 14	Same as Error history data 1.		
	2784 to 2799	0AE0H to 0AEFH	Error history data 15	Same as Error history data 1.		
	2800 to 4095	0AF0H to 0FFFH	System area	—	—	

*1 This value is the value of factory default or the value of initialization by Error history clear command (address: 1000H).

*2 This shows whether reading/writing data from/to a program is possible.

R: Readable

W: Writable

(4) Module control data area (address: 1000H to 14FFH)

Type	Address		Description	Default value *1	Read/Write *2
	Decimal	Hexadecimal			
Station-based control data	4096	1000H	Error history clear command	0	R/W
	4097	1001H	Error history clear completed	0	R
	4098	1002H	Parameter area initialization command	0	R/W
	4099	1003H	Parameter area initialization completed	0	R
	4100	1004H	Module operation information initialization command	0	R/W
	4101	1005H	Module operation information initialization completed	0	R
	4102 to 4351	1006H to 10FFH	System area	—	—
Main module Module-based control data	4352 to 4607	1100H to 11FFH	System area	—	—
Extension module 1 Module-based control data	4608 to 4863	1200H to 12FFH	The remote buffer memory areas of the connected extension module are assigned.	—	—
—	4864 to 5375	1300H to 14FFH	System area	—	—

*1 Value at the time of turning off and on the module power supply or at the time of remote reset.



*2 This shows whether reading/writing data from/to a program is possible.

R: Readable

W: Writable

(a) Module control data area of extension modules

The remote buffer memory areas differ depending on the model of extension module.

- For the extension D/A converter module, refer to  Page 44, Section 3.7.2 (3).
- For the extension A/D converter module, refer to  CC-Link IE Field Network Analog-Digital Converter Module User's Manual.
- For the extension I/O module, refer to  CC-Link IE Field Network Remote I/O Module User's Manual.

3.7.2 Extension D/A converter module

(1) Parameter area (address: 0200H to 02FFH)

Type	Address		Description	Default value ^{*1}	Read/Write ^{*2}	Necessity of RY9 ^{*3}
	Decimal	Hexadecimal				
Extension module 1 Module-based parameter data	512	0200H	Extension module identification code	0000H	R/W	○
	513	0201H	System area	—	—	—
	514	0202H	D/A conversion enable/disable setting	000FH	R/W	○
	515	0203H	Range setting	0000H	R/W	○
	516	0204H	Analog output HOLD/CLEAR setting	0000H	R/W	○
	517	0205H	Alert output setting	000FH	R/W	○
	518	0206H	CH1 Alert output upper limit value	0000H	R/W	○
	519	0207H	CH1 Alert output lower limit value	0000H	R/W	○
	520	0208H	CH2 Alert output upper limit value	0000H	R/W	○
	521	0209H	CH2 Alert output lower limit value	0000H	R/W	○
	522	020AH	CH3 Alert output upper limit value	0000H	R/W	○
	523	020BH	CH3 Alert output lower limit value	0000H	R/W	○
	524	020CH	CH4 Alert output upper limit value	0000H	R/W	○
	525	020DH	CH4 Alert output lower limit value	0000H	R/W	○
	526	020EH	Scaling enable/disable setting	000FH	R/W	○
	527	020FH	CH1 Scaling lower limit value	0	R/W	○
	528	0210H	CH1 Scaling upper limit value	0	R/W	○
	529	0211H	CH2 Scaling lower limit value	0	R/W	○
	530	0212H	CH2 Scaling upper limit value	0	R/W	○
	531	0213H	CH3 Scaling lower limit value	0	R/W	○
532	0214H	CH3 Scaling upper limit value	0	R/W	○	
533	0215H	CH4 Scaling lower limit value	0	R/W	○	
534	0216H	CH4 Scaling upper limit value	0	R/W	○	
535 to 767	0217H to 02FFH	System area	—	—	—	

*1 This value is the value of factory default or the value of initialization by Parameter area initialization command (address: 1002H).

*2 This shows whether reading/writing data from/to a program is possible.
R: Readable
W: Writable

*3 This shows the items enabled by tuning on and off Initial data setting request flag (RY9).

(2) Monitor area (address: 0700H to 07FFH)

Type	Address		Description	Default value ^{*1}	Read/Write ^{*2}
	Decimal	Hexadecimal			
Extension module 1	1792	0700H	Extension module identification code	0	R
Module-based monitor data	1793 to 2047	0701H to 07FFH	System area	—	—

*1 Value at the time of turning off and on the module power supply or at the time of remote reset.

*2 This shows whether reading/writing data from/to a program is possible.
R: Readable
W: Writable

(3) Module control data area (address: 1200H to 12FFH)

Type	Address		Description	Default value ^{*1}	Read/Write ^{*2}
	Decimal	Hexadecimal			
Extension module 1 Module-based control data	4608 to 4863	1200H to 12FFH	System area	—	—

*1 Value at the time of turning off and on the module power supply or at the time of remote reset.

*2 This shows whether reading/writing data from/to a program is possible.

R: Readable

W: Writable

CHAPTER 4 PROCEDURES BEFORE OPERATION

This chapter describes the procedures before operation.

Check box

Setting a station number

Set the station number of the main D/A converter module.



Page 50, Section 6.1



Connection

When using an extension module, connect the extension module to the main D/A converter module.
After that, mount the main D/A converter module on a DIN rail.



Page 51, Section 6.2
Page 53, Section 6.3



Wiring

Carry out wiring of a power supply, Ethernet cables, and external devices to the main D/A converter module.
When using an extension module, carry out wiring of a power supply and external devices to the extension module.



Page 58, Section 6.4
Page 60, Section 6.5
Page 63, Section 6.6



Parameter settings and programming

Set parameters and create a program.



Page 69, Section 7.1
Page 76, Section 7.2*¹
Page 137, CHAPTER 9



Offset/gain setting

To use user range, configure the offset/gain setting.



Page 83, Section 7.3

*1 To replace the module, refer to the point below.

Point

To replace the module, follow the procedure described below:

- Turn off the module power supply and remove the D/A converter module.
- Prepare a new D/A converter module and follow the illustration above as instructed from "Setting a station number" to "Parameter settings and programming". (No re-setting of network parameters of the master station is required.)
- If necessary to use the user range, perform the offset/gain setting.
- Carry out operation check and then restart the control.

Memo

CHAPTER 5 SYSTEM CONFIGURATION

This chapter describes how to configure the system using D/A converter modules.

For the configuration on CC-Link IE Field Network, refer to the following:

📖 User's manual for the master/local module used

5.1 System Configuration with D/A Converter Module

The following figure shows the system configuration including a D/A converter module.

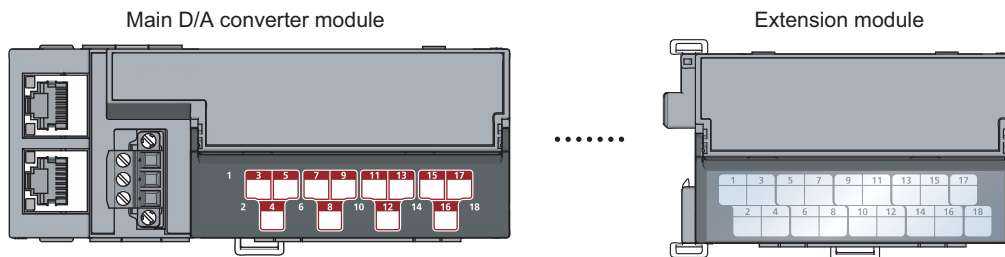

5.2 Applicable Systems

(1) Supported master station

For the use of a D/A converter module, select a product for the master station from the following list.

Model	First five digits of serial number
RJ71GF11-T2 RJ71EN71	(no restriction)
RD77GF32, RD77GF16, RD77GF8, RD77GF4	
LJ71GF11-T2	14102 or later
QJ71GF11-T2	
QD77GF16	15092 or later

The above information of "supported master station" is information at the time of this revision.

For the latest information, refer to the CC-Link Partner Association's website.

www.cc-link.org

(2) Connectable modules

(a) Extension modules that can be connected to the main D/A converter module

Either one of the following extension modules can be connected to the main D/A converter module.

Classification	Model
Extension input module	NZ2EX2B1-16D
Extension output module	NZ2EX2B1-16T
	NZ2EX2B1-16TE
Extension A/D converter module	NZ2EX2B-60AD4
Extension D/A converter module	NZ2EX2B-60DA4

(b) Main modules to which the extension D/A converter module can be connected

The extension D/A converter module can be connected to either one of the following main modules.

Classification	Model
Main A/D converter module	NZ2GF2BN-60AD4
Main D/A converter module	NZ2GF2BN-60DA4

(3) Ethernet cables

For the specifications of the Ethernet cable, refer to the following:

 User's manual for the master/local module used

(4) Supported software package

Configuring and diagnosing the D/A converter module requires GX Works2 or GX Works3. According the master station used, install the following version of GX Works2 or GX Works3.

Engineering tool	Software version
GX Works2	Version 1.525X or later
GX Works3	Version 1.005F or later

Point 

When the latest profile of the D/A converter module is necessary, please consult your local Mitsubishi representative.

The profile is a setting file that stores information required for the start-up, operation, and maintenance of devices supporting the CC-Link family. A module is added to "Module List" of "CC IE Field Configuration" window by profile registration to GX Works2 or GX Works3. For the profile registration, refer to the following.

 GX Works2 Version 1 Operating Manual (Common)

 GX Works3 Operating Manual

CHAPTER 6 INSTALLATION AND WIRING

This chapter describes the installation and wiring of the D/A converter module.

6.1 Station Number Setting

(1) Setting method

Set the station number with the rotary switch on the front of the module. Set the station number in the power-off state because the set value is enabled at power-on.

- The dial x10 is used to set the hundreds and tens place of a station number.
- The dial x1 is used to set the ones place of a station number.

Ex. For the station number 115, set the switch as shown below.

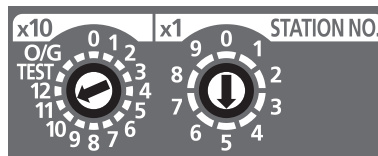

(2) Setting range

Set the station number, which can be from 1 to 120. A value other than 1 to 120 causes a communication error, resulting in the D LINK LED flashing.

Point

- While the module power supply is in an on state, changing the station number setting switch causes a minor error, resulting in the ERR. LED flashing. When the station number setting switch is set back to the previous state, the module recovers from the error after five seconds, resulting in the ERR. LED turning off.
 - For the station number setting, avoid duplication with the other station numbers. Number duplication causes a communication error, which does not allow the D LINK LED to light up.
-

6.2 Installation Environment and Installation Position

6.2.1 Installation environment

(1) Installation location

Do not install the D/A converter module in places where:

- Ambient temperature is outside the range of 0 to 55°C;
- Ambient humidity is outside the range of 5 to 95% RH;
- Condensation occurs due to rapid temperature change;
- Corrosive gas or combustible gas is present;
- There are a high level of conductive powder such as dust and iron powder, oil mist, salinity, or organic solvent;
- It is exposed to direct sunlight;
- A strong electric field or strong magnetic field is generated; and
- The module is subject to vibration and shock.

(2) Installation surface

Install the D/A converter module on a flat surface. Unevenness on the installation surface causes application of an excessive force to the printed-circuit board, which may lead to a malfunction.

6.2.2 Installation position

When installing the D/A converter module in a control panel, provide a clearance of at least 60mm from the surroundings including adjacent structures and modules to ensure good ventilation and easy module change.

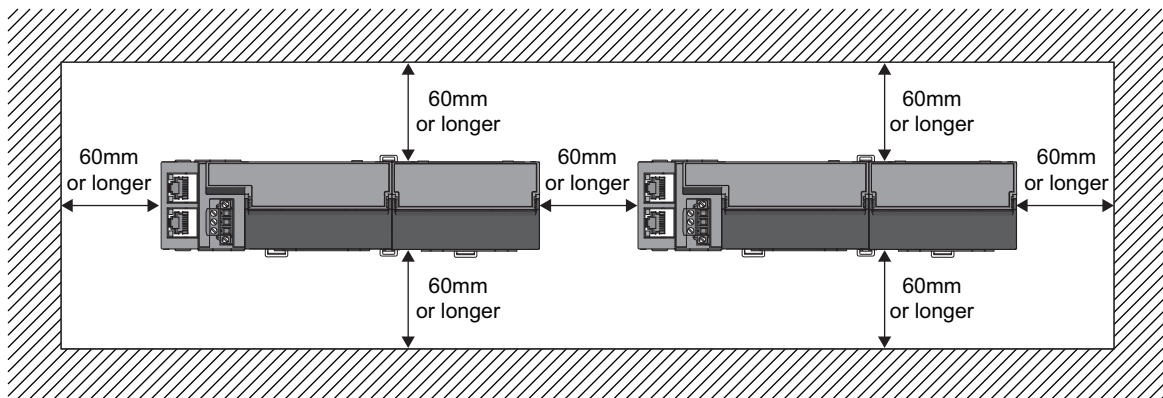

6.2.3 Installation direction

The D/A converter module can be installed in six directions.
Use a DIN rail to install the module.

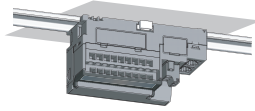

Downward installation

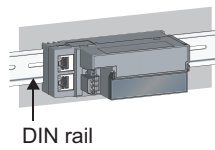

DIN rail
Horizontal installation

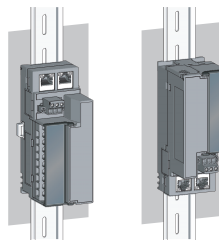

Vertical installation

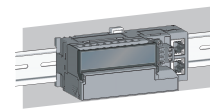

Horizontal installation
(upside down)

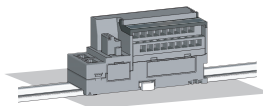

Upward installation

6.3 Installation

6.3.1 How to connect an extension module

(1) Connecting procedure

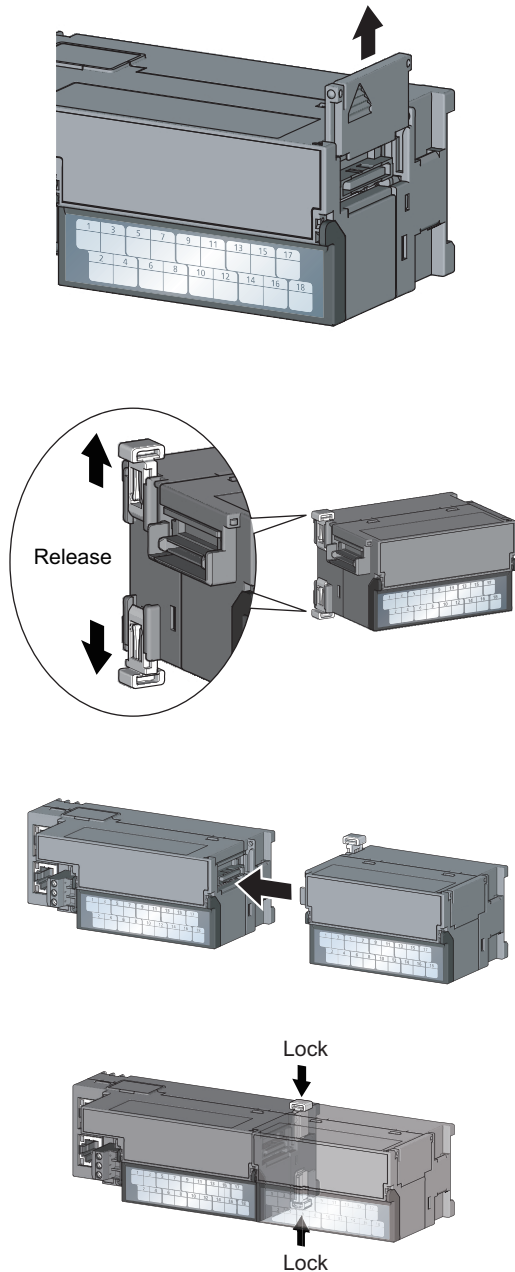

- 1. Remove the cover on the side of the main module.**
Save the removed cover without losing it.
- 2. Release the module joint levers (two points) on the side of the extension module. Slide the levers vertically.**
- 3. Insert the connector of the extension module into that of the D/A converter module so that they are securely engaged.**
- 4. Lock the module joint levers (two points) on the side of the extension module. Slide the levers toward the module.**
Check that the modules are securely connected.

(2) Disconnecting procedure

Disconnect the extension module in a procedure opposite to the connecting procedure.

Point

- Shut off the external power supply for the system in all phases before connecting or disconnecting extension modules.
 - Lock the module joint levers securely. Failure to do so may cause malfunction, failure, or drop of the module.
-

6.3.2 Mounting modules on a DIN rail

Point

The usage instructions for a DIN rail stopper is shown as one example. Fix the module according to the manual of the DIN rail stopper used.

(1) Mounting procedure

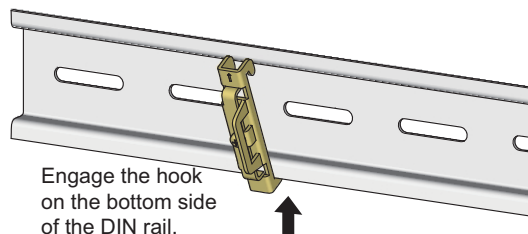
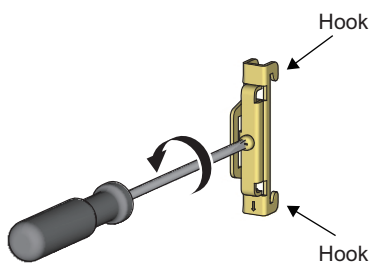
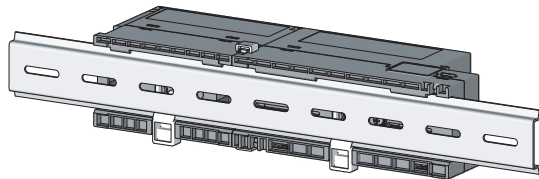
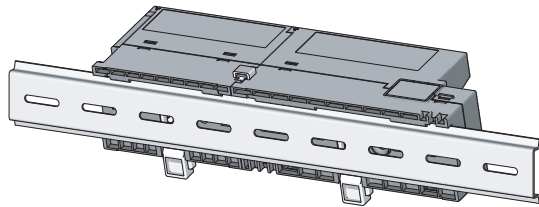
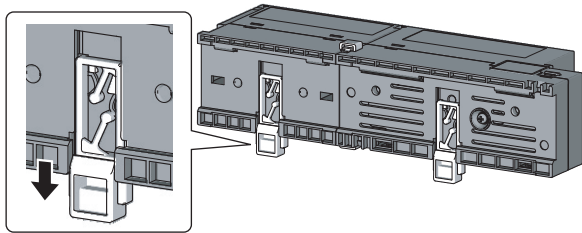

- 1. Pull down all DIN rail hooks on the back of the modules.**

The levers should be pulled down until it clicks.

- 2. Hang the upper tabs of the modules on a DIN rail, and push the modules in position.**

- 3. Lock the DIN rail hooks to the DIN rail to secure the modules in position.**

Push each hook up until it clicks. If the hooks are beyond the reach, use a tool such as a screwdriver.

- 4. Loosen the screw on the DIN rail stopper.**

- 5. Hitch the bottom hook of the DIN rail stopper to the bottom of the DIN rail.**

Hitch the hook according to the orientation of the arrow on the front of the stopper.

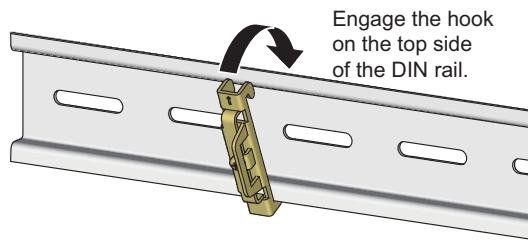

6. Hitch the upper hook of the DIN rail stopper to the top of the DIN rail.

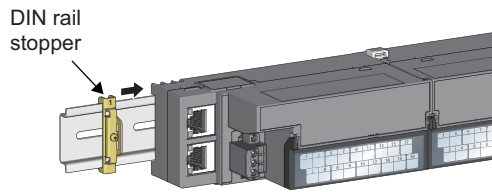

7. Slide the DIN rail stopper up to the left side of the modules.

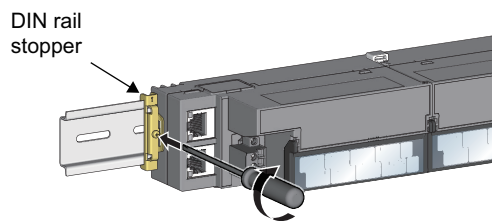

8. Hold the DIN rail stopper in the direction opposite to the arrow on the stopper and tighten the screw with a screwdriver.

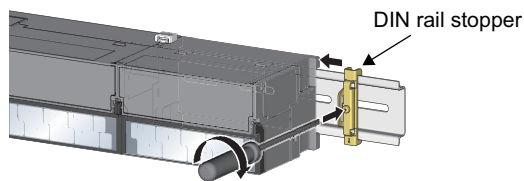

9. Install the DIN rail stopper on the right side of the module in the same procedure.

For the installation on the right side, be aware that the orientation of the DIN rail stopper is upside down.

Point!

Do not slide modules from the edge of the DIN rail when mounting them. Doing so may damage the metal part located on the back of the module.

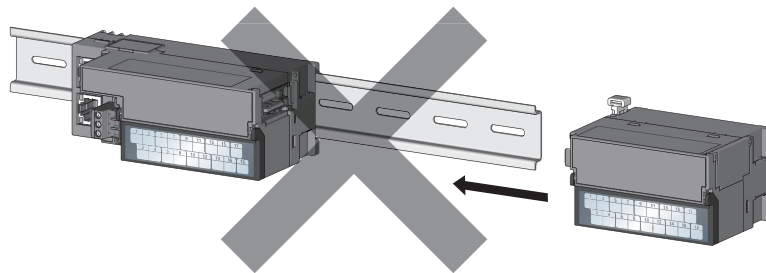

(2) Removal procedure

Remove the modules from the DIN rail in a procedure opposite to the mounting procedure.

(3) Applicable DIN rail model (compliant with IEC 60715)

- TH35-7.5Fe
- TH35-7.5Al

(4) Space between DIN rail mounting screws

When mounting a DIN rail, tighten the screws at a pitch of 200mm or less.

(5) DIN rail stopper

Use a stopper that is attachable to the DIN rail.

6.4 Wiring to Terminal Block for Module Power Supply and FG

This section describes how to wire a terminal block for module power supply and FG to the main D/A converter module.

Note that the descriptions are the same for the external D/A converter module.

(1) Tightening torque

Tighten the terminal block screws within the following specified torque range.

Tightening the screws too much may damage the module case.

Screw type	Tightening torque range
Terminal block mounting screw (M2.5)	0.2 to 0.3N·m
Terminal screw (M2.5)	0.5 to 0.6N·m

(2) Suitable wire

The table below shows the suitable wire for connection to the terminal block for module power supply and FG.

Diameter	Type	Material	Temperature rating
20 to 16 AWG	Stranded	Copper	75°C or higher

For applicable solderless terminals, refer to the following:

- Performance Specifications ( Page 24, Section 3.2)

(3) Installing and removing the terminal block

To remove the terminal block, loosen the terminal block mounting screw with a flathead screwdriver.

To install the terminal block, tighten the terminal block mounting screw with a flathead screwdriver.

Failure to secure the terminal block may cause drop, short circuit, or malfunction.

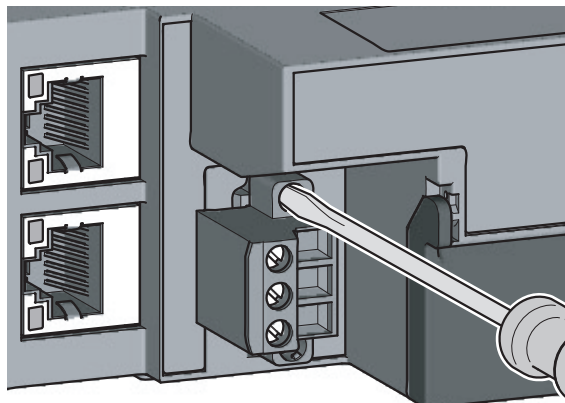

(4) Connecting and disconnecting a cable

To connect a cable, with the terminal screw loosened using a flathead screwdriver, insert the wire and then tighten the terminal screw.

To disconnect the cable, with the terminal screw loosened using a flathead screwdriver, pull out the wire.

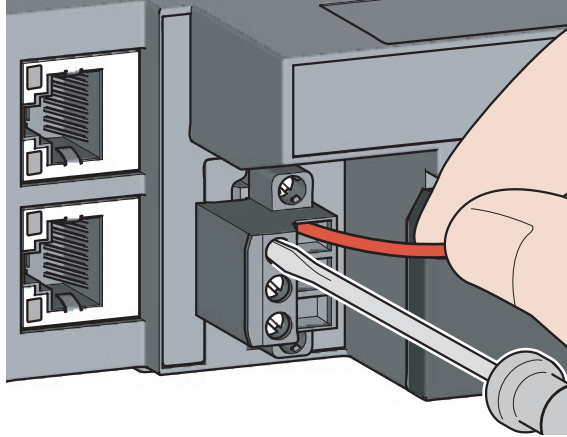

(5) Cable terminal processing

Strip the cable sheath approximately 10mm from the end.

To use a bar solderless terminal, connect it to the stripped part.

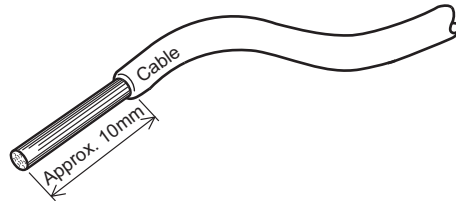

(6) List of bar solderless terminals

The following table lists recommended bar solderless terminals.

Product name	Model name	Applicable wire size	Contact
Bar solderless terminal	TE 0.5-10	0.5mm ²	NICHIFU Co., Ltd.
	TE 0.75-10	0.75mm ²	
	TE 1.0-10	0.9 to 1.0mm ²	
	TE 1.5-10	1.25 to 1.5mm ²	
Bar solderless terminal tool	NH79	—	
Bar solderless terminal	AI 0.5-10WH	0.5mm ²	Phoenix Contact Co., Ltd.
	AI 0.75-10GY	0.75mm ²	
	AI 1-10RD	1.0mm ²	
	AI 1.5-10BK	1.5mm ²	
Bar solderless terminal tool	CRIMPFOX6	—	

6.5 Wiring of Ethernet Cable

(1) Connecting an Ethernet cable

(a) Connecting

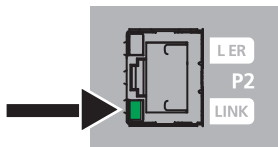
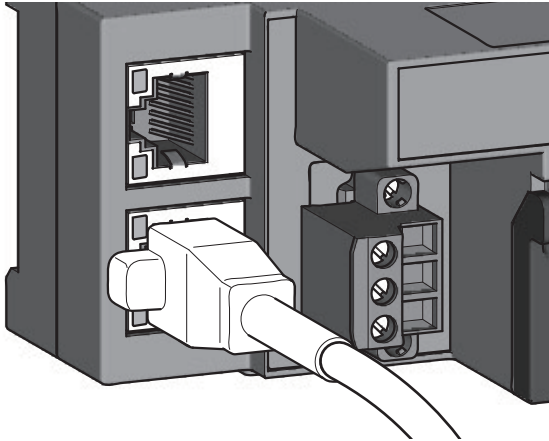

1. Turn off the module power supply of the main D/A converter module and the power supply of the external device.
2. With attention to the orientation of the cable, push the Ethernet cable connector into the main D/A converter module until it clicks.
3. Power on the module.
4. Power on the external device.
5. Check if the LINK LED on the port into which the Ethernet cable is connected is on.

Point

- The time taken for the LINK LED to turn on after connection of the cable may vary. The LINK LED normally turns on in a few second. However, if link-up processing is repeated due to a condition of a device on the line, the longer time may be required. If the LINK LED does not turn on, refer to the following and take a corrective action.

☞ Page 164, Section 11.4.1 (8)

- PORT1 connector and PORT2 connector need not to be distinguished. When only one connector is used in star topology, either PORT1 connector or PORT2 connector can be used.

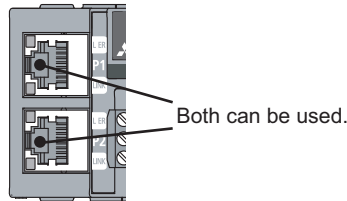

- When two connectors are used in line topology or ring topology, there is no restriction on the connection combination of PORT1 connector and PORT 2 connector. For example, the connection from PORT1 to PORT1 and the connection from PORT1 to PORT2 are both possible.

Connection from port 1 to port 1, and from port 2 to port 2

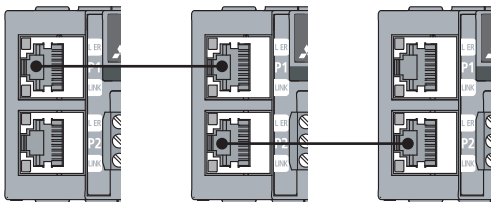

Connection from port 1 to port 2

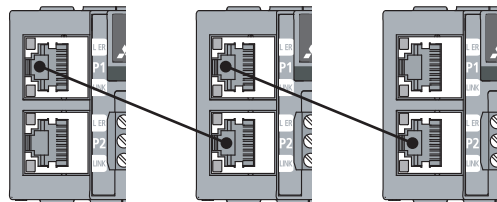

(b) Disconnecting

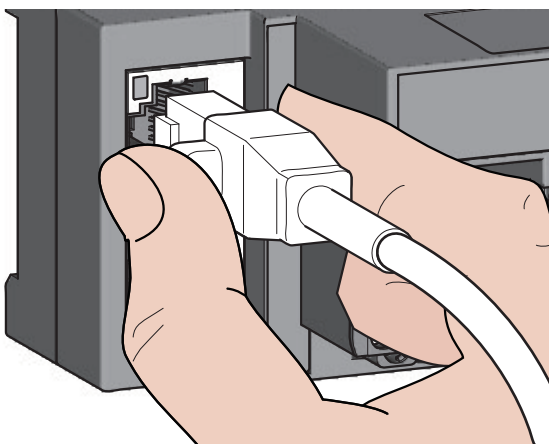

1. Power off the module.
2. With the latch of the Ethernet cable pressed, unplug the cable.

(2) Precautions

(a) Laying Ethernet cables

- The Ethernet cables must be placed in the duct or fixed by clamp. If not, dangling cable may swing or inadvertently be pulled, resulting in damage to the module or cables or malfunction due to poor contact.
- Do not touch the core of the connector of the cable or the module, and protect it from dirt and dust. If any oil from your hand, or any dirt or dust sticks to the core, it can increase transmission loss, causing data link to fail.
- Check the following:
 - Is any Ethernet cable disconnected?
 - Does any Ethernet cable short?
 - Are the connectors securely connected?

(b) Broken cable latch

Do not use Ethernet cables with broken latches. Doing so may cause the cable to unplug or malfunction.

(c) Connecting and disconnecting the Ethernet cable

Hold the connector part when connecting and disconnecting the Ethernet cable. Pulling the cable connected to the module may result in damage to the module or cable or malfunction due to poor contact.

(d) Connector to which an Ethernet cable is not connected

To prevent dust from entering the module, attach the provided connector cover.

(e) Maximum station-to-station distance (maximum cable length)

The maximum station-to-station distance is 100m. However, the distance may be shorter depending on the operating environment of the cable. For details, contact the manufacturer of the cables used.

(f) Bending radius of the Ethernet cable

There are restrictions on the bending radius of the Ethernet cable. Check the bending radius in the specifications of the Ethernet cables used.

6.6 Wiring of Terminal Block and External Devices

(1) Tightening torque

Tighten the terminal block screws within the following specified torque range.

Tightening the screws too much may damage the module case.

Screw type	Tightening torque range
Terminal screw (M3)	0.43 to 0.57N·m
Terminal block mounting screw (M3.5)	0.68 to 0.92N·m

The following table shows applicable solderless terminals to be connected to the terminal block. For wiring, use the wire and tightening torque as specified in the table below. Use UL-listed solderless terminals, and for processing, use the tool recommended by their manufacturers. Note that a solderless terminal with an insulation sleeve cannot be used.

Solderless terminal		Wire			
Model	Applicable tightening torque	Diameter	Type	Material	Temperature rating
R1.25-3	0.43 to 0.57N·m	22 to 14 AWG	Stranded	Copper	75°C or higher
V2-MS3					
RAP2-3SL					
TGV2-3N					

(2) Removing and installing the terminal block

(a) Removal procedure

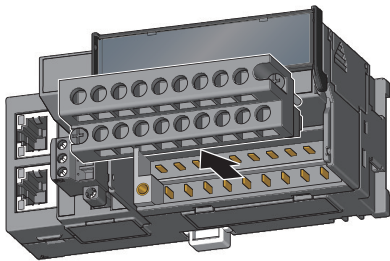
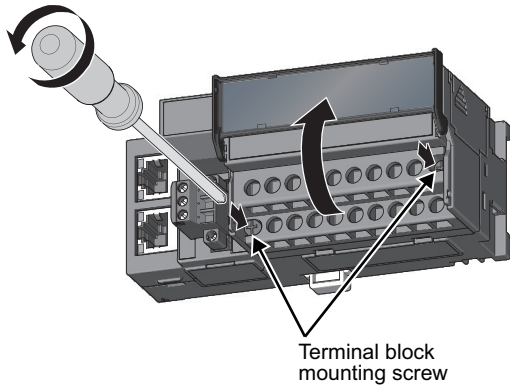

1. Open the terminal block cover and loosen the terminal block mounting screws (two points).

2. Loosening the terminal block mounting screws (two points) allows the two-piece terminal block to lift and be removed.

(b) Installation procedure

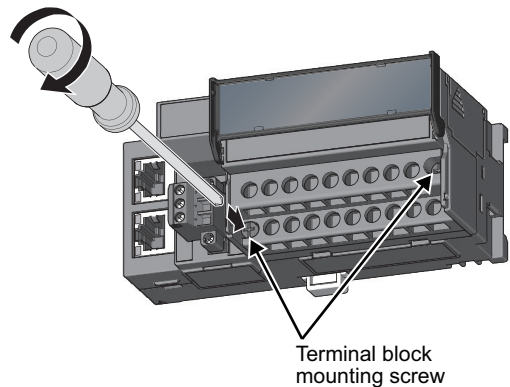
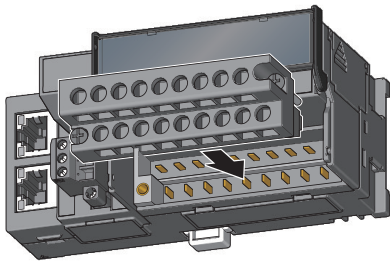

1. Open the terminal block cover to install the two-piece terminal block.

2. Tighten the terminal block mounting screws.

(3) Wiring of the terminal block and external devices

(a) Signal name

The following shows signal names of the terminal block.

1	3	5	7	9	11	13	15	17
NC	CH1 V+	CH1 I+	CH2 V+	CH2 I+	CH3 V+	CH3 I+	CH4 V+	CH4 I+
2	4	6	8	10	12	14	16	18
NC	CH1 COM	NC	CH2 COM	NC	CH3 COM	NC	CH4 COM	NC

Pin number	Signal name	
1	NC	
2	NC	
3	CH1 V+	
4		COM
5		I+
6	NC	
7	CH2 V+	
8		COM
9		I+
10	NC	
11	CH3 V+	
12		COM
13		I+
14	NC	
15	CH4 V+	
16		COM
17		I+
18	NC	

Point

Do not wire the NC terminals. Incorrect wiring may cause failure or malfunction of the module.

(b) Wiring to the terminal block

The following shows wiring to the terminal block.

- For voltage output

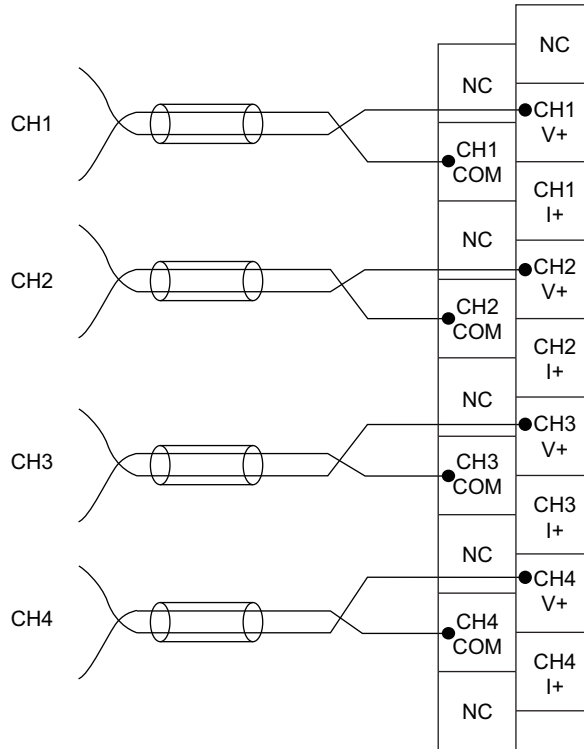

- For current output

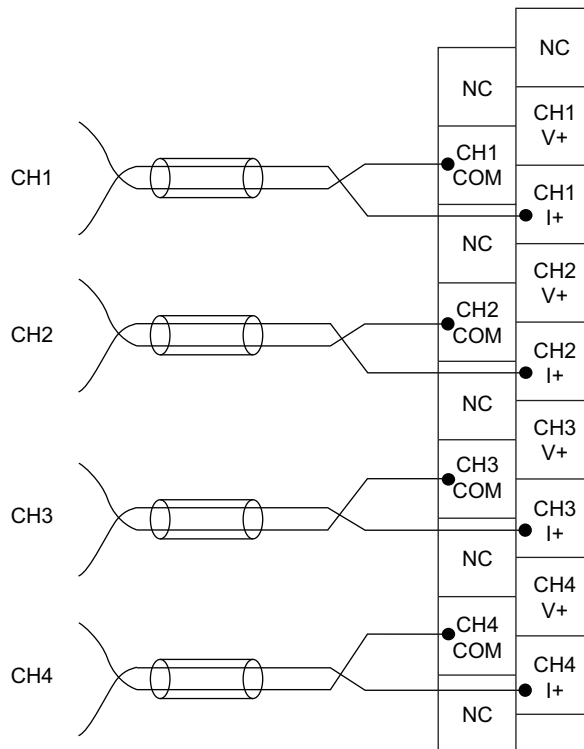

(c) Precautions for external wiring

To obtain the maximum performance from the functions of the D/A converter module and improve the system reliability, an external wiring with high durability against noise is required. Precautions for external wiring are as follows:

- Use separate cables for the AC control circuit and the external output signals of the D/A converter module to avoid the influence of the AC side surges or induction.
- Do not install cables together with the main circuit lines, high voltage lines, or power cables for equipment other than the programmable controller. Noise, surges, or induction may affect the system.
- Ground the shielded wires or shielded cables at one point on the programmable controller side. However, depending on the external noise conditions, it may be better to ground them externally.

(d) External wiring

The following shows the external wiring.

- For voltage output

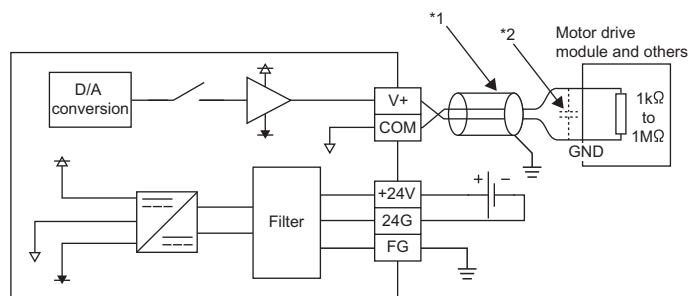

*1 For the cable, use the 2-core shielded twisted pair cable.

*2 If there is noise or ripples in the external wiring, connect a 0.1 to 0.47 μ F capacitor (25V or higher voltage-resistant product) to the input terminal of the external device.

- For current output

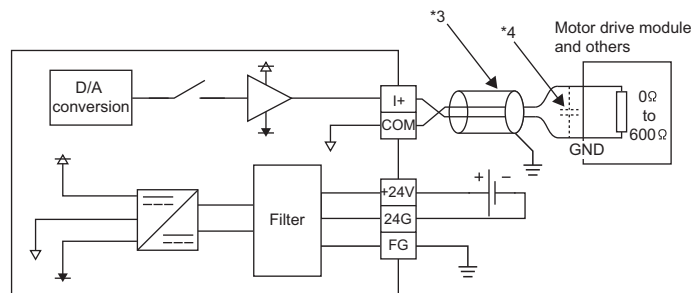

*3 For the cable, use the 2-core shielded twisted pair cable.

*4 If there is noise or ripples in the external wiring, connect a 0.1 to 0.47 μ F capacitor (25V or higher voltage-resistant product) to the input terminal of the external device.

(e) Wiring method

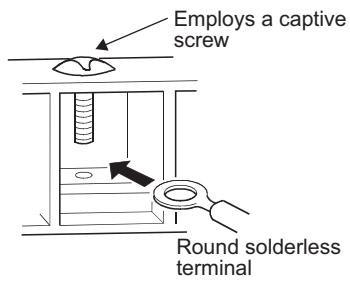

- 1. Loosen the terminal screw. A round solderless terminal can be connected as it is.**

Point

- Avoid contact of the terminal and the screw with oil. Failure to do so may damage the screw.
- The number of the inserted applicable solderless terminals must be two or less.
When inserting two applicable solderless terminals, insert them back-to-back. Otherwise the screw cannot be tightened, possibly causing damage to it.
- Tighten the terminal screw with an applicable screwdriver. Tightening with an inapplicable screwdriver may damage the screw.

CHAPTER 7 VARIOUS SETTINGS

This chapter describes the setting procedures of the D/A converter module.

7.1 Parameter Settings

Set the parameter of this module with the network parameter written to the CPU module of the master station. For how to set up the master station, refer to the following:

 User's manual for the master/local module used

Remark

- Place a checkmark in the "Set the network configuration settings in CC IE Field configuration window" box on the "MELSECNET/CC IE/Ethernet Module Configuration" window in advance.

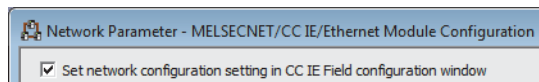

- To select the main D/A converter module in the CC IE Field Configuration window, select "NZ2GF2B-60DA4" from the "Module list" window.
- To select an extension module in the "CC IE Field Configuration" window, select the following models from the "Module List" window.

Extension module type	Name
Extension Digital Input Module	NZ2EX-16 (DI)
Extension Digital Output Module	NZ2EX-16 (DO)
Extension A/D Converter Module	NZ2EX2B-60AD4
Extension D/A Converter Module	NZ2EX2B-60DA4

- Setting fewer points of the remote I/O signal or remote register than actual points that the main D/A converter module or the extension module possesses does not cause an error. In this case, data of all the set points are subject to cyclic transmission in order.

(1) Precautions

(a) Before parameter settings

For the precautions before parameter settings, refer to the following.

 GX Works3 Operating Manual

 GX Works2 Version 1 Operating Manual (Common)

(b) Parameter settings

- When using the D/A converter module, always enable the block data assurance per station. If it is disabled, correct operation of the D/A converter module cannot be guaranteed. For the block data assurance per station, refer to the following:  User's manual for the master/local module used

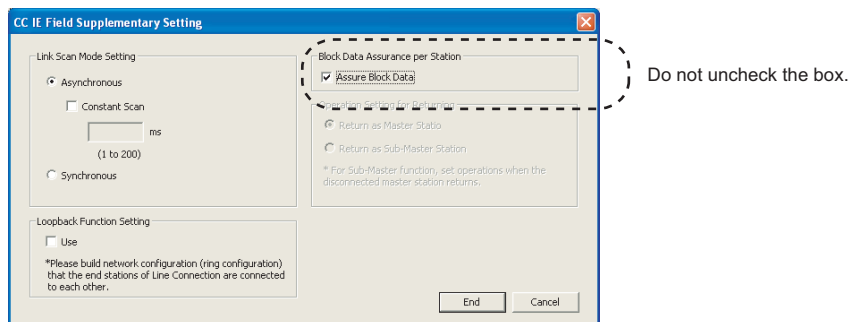

- Do not set the parameters using the CCPASET instruction in the master station. Executing the CCPASET instruction results in the module operating with block data assurance per station deactivated, where proper performance as the D/A converter module cannot be guaranteed.
- When using the extension module, be sure to write the module parameters ( Page 71, Section 7.1 (2)). If the parameters of the extension module has not been written, the error code (1F30H) is stored in Latest error code (RWr0), Error flag (RXA) turns on, and the ERR. LED lights up.

(2) Setting procedure

1. Open the "CC IE Field Configuration" window.

- For the master/local module QJ71GF11-T2

Project window ⇒ [Parameter] ⇒ [Network Parameter] ⇒ [Ethernet/CC IE/MELSECNET] ⇒

 button

- For the master/local module LJ71GF11-T2

Project window ⇒ [Parameter] ⇒ [Network Parameter] ⇒ [Ethernet/CC IE Field] ⇒

 button

2. On the "CC IE Field Configuration" window, from "List of stations", select the main D/A converter module.

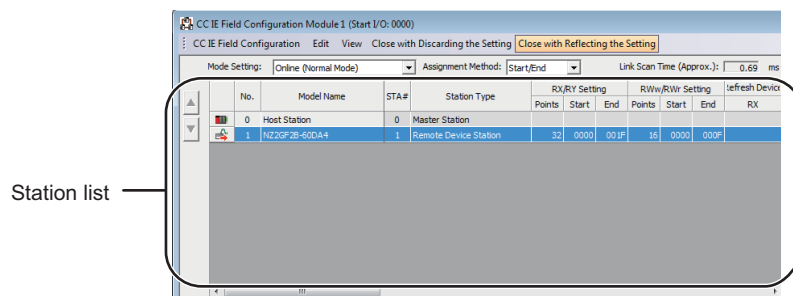

3. Open the "Parameter Processing of Slave Station" window.

 [CC IE Field Configuration] ⇒ [Online] ⇒ [Parameter Processing of Slave Station]

4. Set "Method selection" to "Parameter write".

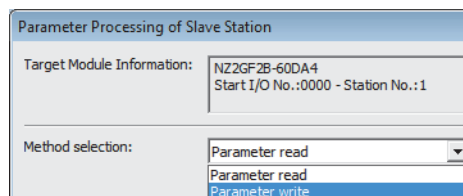

5. Double-click the item to change the setting, and input the setting value.

- Items to be selected from a pull-down list
Double-click the item to be set, and from the pull-down list that appears, select the desired item.
- Items to be entered via text box
Double-click the item to be set, and enter the desired value.

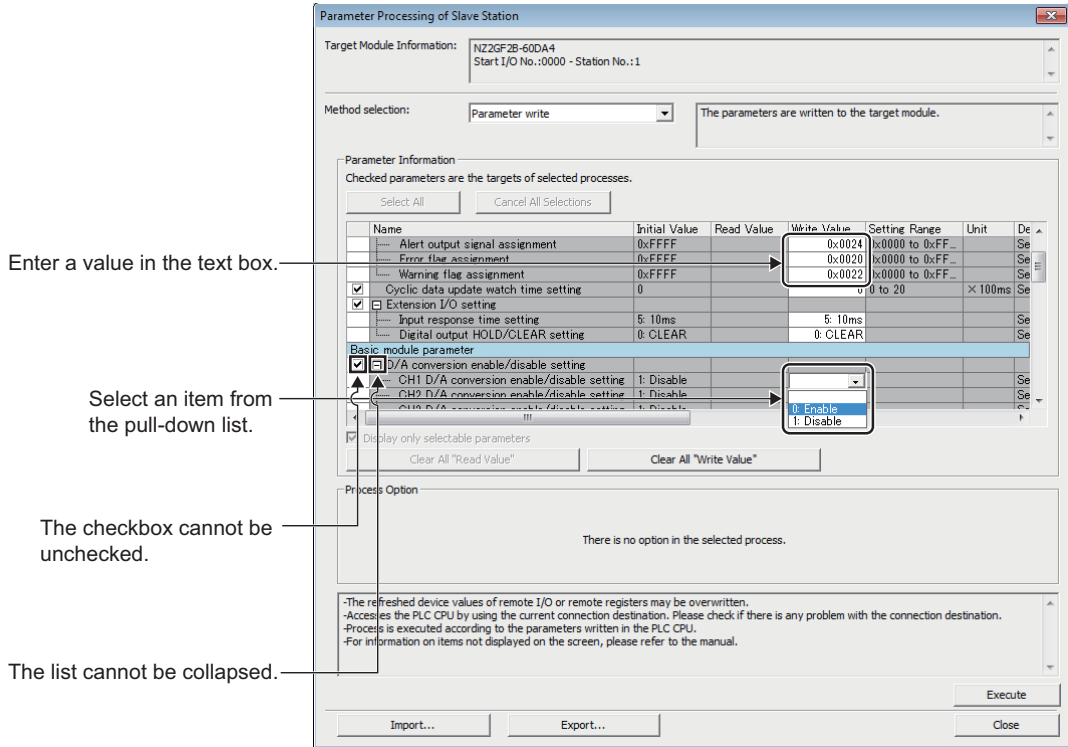

- Station parameter

Setting item		Reference
Mode switch		Page 86, Section 8.2 (1)
External signal assignment function	Trigger output signal assignment	Page 130, Section 8.16.1 (2)
	Alert output signal assignment	
	Error flag assignment	
	Warning flag assignment	
Cyclic data update watch time setting		Page 95, Section 8.8
Extension I/O setting	Input response time setting	Page 129, Section 8.16.1
	Digital output HOLD/CLEAR setting	

- Basic module parameter

Setting item		Reference
D/A conversion enable/disable setting	CH1 D/A conversion enable/disable setting	Page 88, Section 8.3
	CH2 D/A conversion enable/disable setting	
	CH3 D/A conversion enable/disable setting	
	CH4 D/A conversion enable/disable setting	
Range setting	CH1 Range setting	Page 92, Section 8.6
	CH2 Range setting	
	CH3 Range setting	
	CH4 Range setting	
Analog HOLD/CLEAR setting	CH1 Analog output HOLD/CLEAR setting	Page 93, Section 8.7
	CH2 Analog output HOLD/CLEAR setting	
	CH3 Analog output HOLD/CLEAR setting	
	CH4 Analog output HOLD/CLEAR setting	

Setting item		Reference
Alert output function	CH1 Alert output setting	Page 107, Section 8.12
	CH1 Alert output upper limit value	
	CH1 Alert output lower limit value	
	CH2 Alert output setting	
	CH2 Alert output upper limit value	
	CH2 Alert output lower limit value	
	CH3 Alert output setting	
	CH3 Alert output upper limit value	
	CH3 Alert output lower limit value	
	CH4 Alert output setting	
	CH4 Alert output upper limit value	
	CH4 Alert output lower limit value	
Scaling function	CH1 Scaling enable/disable setting	Page 96, Section 8.9
	CH1 Scaling upper limit value	
	CH1 Scaling lower limit value	
	CH2 Scaling enable/disable setting	
	CH2 Scaling upper limit value	
	CH2 Scaling lower limit value	
	CH3 Scaling enable/disable setting	
	CH3 Scaling upper limit value	
	CH3 Scaling lower limit value	
	CH4 Scaling enable/disable setting	
	CH4 Scaling upper limit value	
	CH4 Scaling lower limit value	

- Ext. module 1_Module parameter

Setting item		Reference
Ext. module 1_D/A conversion enable/disable setting	Ext. module 1_CH1 D/A conversion enable/disable setting	Page 88, Section 8.3
	Ext. module 1_CH2 D/A conversion enable/disable setting	
	Ext. module 1_CH3 D/A conversion enable/disable setting	
	Ext. module 1_CH4 D/A conversion enable/disable setting	
Ext. module 1_Range setting	Ext. module 1_CH1 Range setting	Page 92, Section 8.6
	Ext. module 1_CH2 Range setting	
	Ext. module 1_CH3 Range setting	
	Ext. module 1_CH4 Range setting	
Ext. module 1_Analog output HOLD/CLEAR setting	Ext. module 1_CH1 Analog output HOLD/CLEAR setting	Page 93, Section 8.7
	Ext. module 1_CH2 Analog output HOLD/CLEAR setting	
	Ext. module 1_CH3 Analog output HOLD/CLEAR setting	
	Ext. module 1_CH4 Analog output HOLD/CLEAR setting	

Setting item		Reference
Ext. module 1_Alert output function	Ext. module 1_CH1 Alert output setting	Page 107, Section 8.12
	Ext. module 1_CH1 Alert output upper limit value	
	Ext. module 1_CH1 Alert output lower limit value	
	Ext. module 1_CH2 Alert output setting	
	Ext. module 1_CH2 Alert output upper limit value	
	Ext. module 1_CH2 Alert output lower limit value	
	Ext. module 1_CH3 Alert output setting	
	Ext. module 1_CH3 Alert output upper limit value	
	Ext. module 1_CH3 Alert output lower limit value	
	Ext. module 1_CH4 Alert output setting	
	Ext. module 1_CH4 Alert output upper limit value	
	Ext. module 1_CH4 Alert output lower limit value	
Ext. module 1_Scaling function	Ext. module 1_CH1 Scaling enable/disable setting	Page 96, Section 8.9
	Ext. module 1_CH1 Scaling upper limit value	
	Ext. module 1_CH1 Scaling lower limit value	
	Ext. module 1_CH2 Scaling enable/disable setting	
	Ext. module 1_CH2 Scaling upper limit value	
	Ext. module 1_CH2 Scaling lower limit value	
	Ext. module 1_CH3 Scaling enable/disable setting	
	Ext. module 1_CH3 Scaling upper limit value	
	Ext. module 1_CH3 Scaling lower limit value	
	Ext. module 1_CH4 Scaling enable/disable setting	
	Ext. module 1_CH4 Scaling upper limit value	
	Ext. module 1_CH4 Scaling lower limit value	

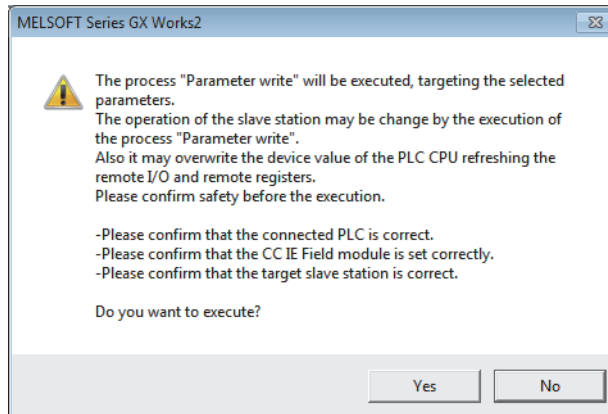

6. Click button to open the following window.



7. Click button.

8. The parameters are written to the D/A converter module.

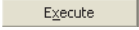
Point

- When using the extension module, also set the parameters of the extension module.
For the parameters of the extension module, refer to the following:
Manual for the extension module used
- Set all the items for the parameter. If any blank exists, the parameters cannot be written to the D/A converter module.
- To read the parameters from the D/A converter module, set "Method selection" to "Parameter read" and click  button.
- The parameters are checked when they are written to the D/A converter module. If the following message is displayed during the writing, take corrective action for the error code in < >. For details on the error codes, refer to the list of error codes ( Page 154, Section 11.2) and the user's manual of the master/local module used.

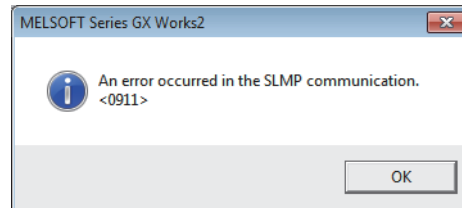

7.2 How to Change the Parameters



This section describes the procedures to change the parameters.

The precautions to take when changing the parameters are the same as the following:

- Precautions (☞ Page 70, Section 7.1 (1))

7.2.1 Changing the network configuration

To change the network configuration reusing the already created project, set the parameters in the following steps:

1. Turn off the module power supply from on.
2. Connect the modules again according to the desired network configuration.
3. Turn on the module power supply from off.
4. Open the "CC IE Field Configuration" window.
 - For the master/local module QJ71GF11-T2
 - ☞ Project window ⇒ [Parameter] ⇒ [Network Parameter] ⇒ [Ethernet/CC IE/MELSECNET] ⇒  button
 - For the master/local module LJ71GF11-T2
 - ☞ Project window ⇒ [Parameter] ⇒ [Network Parameter] ⇒ [Ethernet/CC IE Field] ⇒  button
5. Set up the slave station with drag and drop, and enter the station number for the slave station. Change values as necessary.

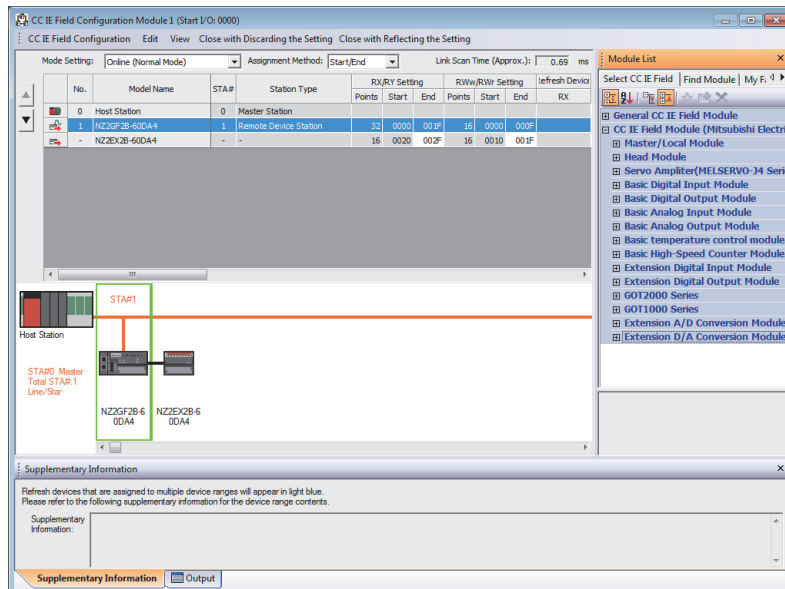

- On the "CC IE Field Configuration" window, from "List of stations", select the main D/A converter module.

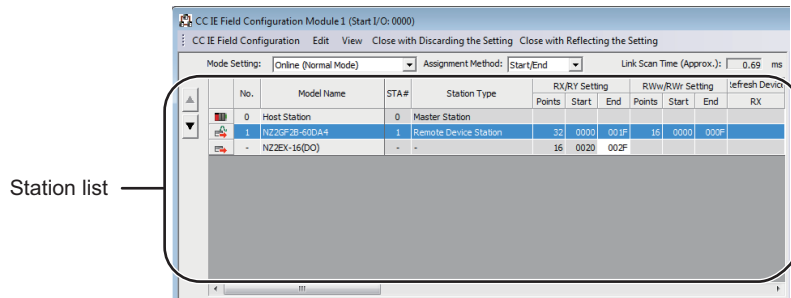

- Open the "Parameter Processing of Slave Station" window.

[CC IE Field Configuration] ⇒ [Online] ⇒ [Parameter Processing of Slave Station]

- Set "Method selection" to "Parameter read".

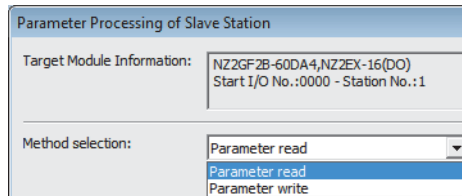

- Click button to open the following window.

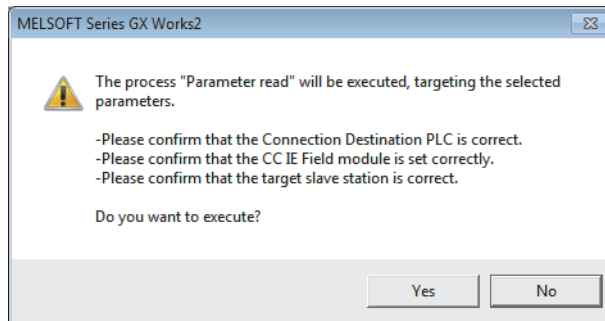

- Click button.

- The parameters are read from the D/A converter module.

Name	Initial Value	Read Value	Write Value	Setting
局単位パラメータ				
<input checked="" type="checkbox"/> Mode switch	9: Automatical judgment mode	9: Automatical judgment mode		
<input checked="" type="checkbox"/> External signal assignment setting				
Trigger output signal assignment	0xFFFF	0xFFFF		0x0000
Alert output signal assignment	0xFFFF	0xFFFF		0x0000
Error flag assignment	0xFFFF	0xFFFF		0x0000
Warning flag assignment	0xFFFF	0xFFFF		0x0000
<input checked="" type="checkbox"/> Cyclic data update watch time setting	0	0		0 to 255
<input checked="" type="checkbox"/> Extension I/O setting				
Input response time setting	5: 10ms	5: 10ms		
Digital output HOLD/CLEAR setting	0: CLEAR	0: CLEAR		

7

7.2 How to Change the Parameters

12. Set "Method selection" to "Parameter write".

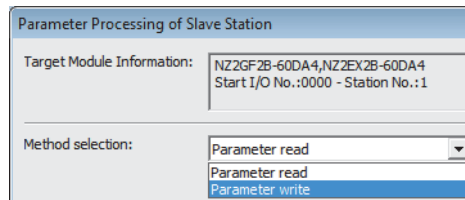

13. Set "Write Value". Follow the next steps to set the value:

- Click the title cell of "Read Value" to select all the items and copy them.
- Click the title cell of "Write Value" to select all the items and paste the copy.
- Select the items to be changed, and set new values.

Name	Initial Value	Read Value	Write Value	Setting Range
局単位パラメータ				
<input checked="" type="checkbox"/> Mode switch	9: Automatical judg...	9: Automatical judg...	9: Automatical judg...	
<input checked="" type="checkbox"/> External signal assignment setting				
..... Trigger output signal assignment	0xFFFF	0xFFFF	0xFFFF	0x0000 to 0xFF...
..... Alert output signal assignment	0xFFFF	0xFFFF	0xFFFF	0x0000 to 0xFF...
..... Error flag assignment	0xFFFF	0xFFFF	0xFFFF	0x0000 to 0xFF...
..... Warning flag assignment	0xFFFF	0xFFFF	0xFFFF	0x0000 to 0xFF...
<input checked="" type="checkbox"/> Cyclic data update watch time setting	0	0	0	0 to 20
<input checked="" type="checkbox"/> Extension I/O setting				
..... Input response time setting	5: 10ms	5: 10ms	5: 10ms	
..... Digital output HOLD/CLEAR setting	0: CLEAR	0: CLEAR	1: HOLD	

14. Click  button to open the following window.

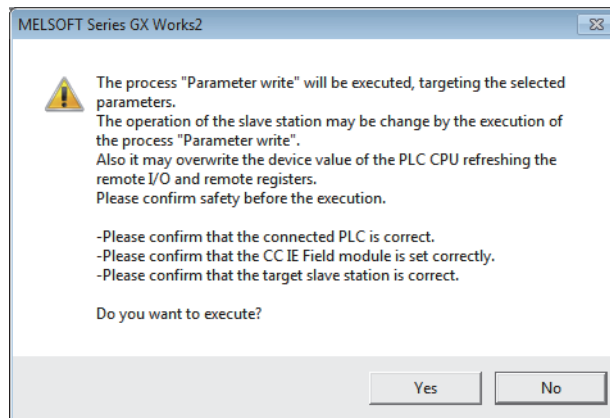

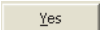
15. Click  button.

16. The parameters are written to the D/A converter module.

Setting up the module parameters of the slave station is now complete.

17. Close the "CC IE Field Configuration" window.

18. Click  button to open the refresh parameter setting window.

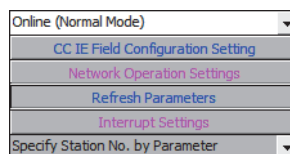

19. Set up the refresh parameters. Change values as necessary.

Assignment Method
 Points/Start
 Start/End

	Link Side					PLC Side			
	Dev. Name	Points	Start	End		Dev. Name	Points	Start	End
Transfer SB	SB	512	0000	01FF	↔	SB	512	0000	01FF
Transfer SW	SW	512	0000	01FF	↔	SW	512	0000	01FF
Transfer 1	RX	64	0000	003F	↔	X	64	1000	103F
Transfer 2	RY	64	0000	003F	↔	Y	64	1000	103F
Transfer 3	RWw	16	0000	000F	↔	W	16	001000	00100F
Transfer 4	RWr	16	0000	000F	↔	W	16	001100	00110F
Transfer 5					↔				
Transfer 6					↔				
Transfer 7					↔				
Transfer 8					↔				

20. Write the set parameters to the CPU module of the master station, and reset the CPU module.

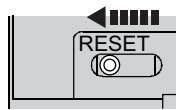

21. Put the CPU module of the master station into RUN.

Setting up the network configuration is now complete.

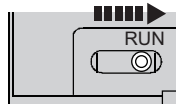

7.2.2 Changing the parameters without changing the network configuration

To change only the module parameters of the already set-up slave station without changing the network configuration, take the following steps:

1. Open the "CC IE Field Configuration" window.

- For the master/local module QJ71GF11-T2

Project window ⇒ [Parameter] ⇒ [Network Parameter] ⇒ [Ethernet/CC IE/MELSECNET] ⇒  button

- For the master/local module LJ71GF11-T2

Project window ⇒ [Parameter] ⇒ [Network Parameter] ⇒ [Ethernet/CC IE Field] ⇒  button

2. On the "CC IE Field Configuration" window, from "List of stations", select the main D/A converter module.

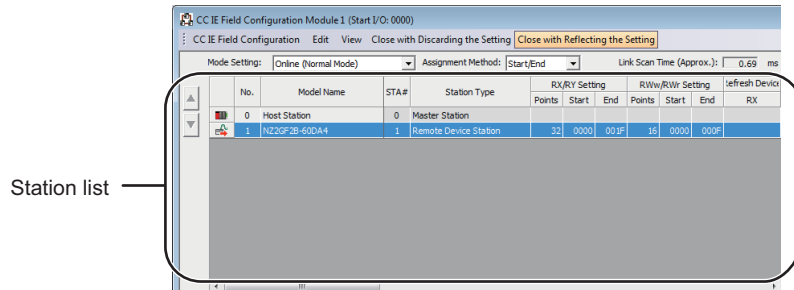

3. Open the "Parameter Processing of Slave Station" window.

 [CC IE Field Configuration] ⇒ [Online] ⇒ [Parameter Processing of Slave Station]

4. Set "Method selection" to "Parameter read".

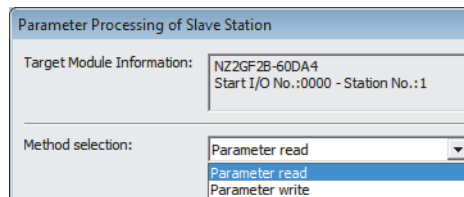

5. Click  button to open the following window.

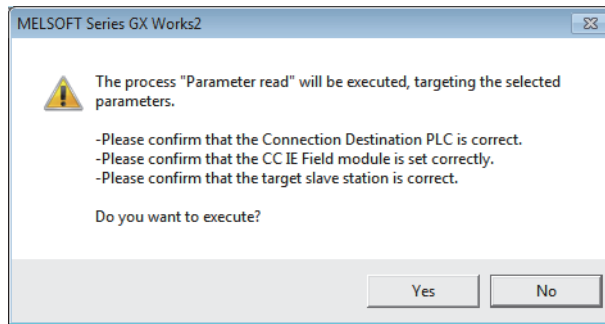

6. Click  button.
 7. The parameters are read from the D/A converter module.

Name	Initial Value	Read Value	Write Value	Setting
局単位パラメータ				
<input checked="" type="checkbox"/> Mode switch	9: Automatical judgment mode	9: Automatical judgment mode		
<input checked="" type="checkbox"/> External signal assignment setting				
Trigger output signal assignment	0xFFFF	0xFFFF		0x0000
Alert output signal assignment	0xFFFF	0xFFFF		0x0000
Error flag assignment	0xFFFF	0xFFFF		0x0000
Warning flag assignment	0xFFFF	0xFFFF		0x0000
<input checked="" type="checkbox"/> Cyclic data update watch time setting	0	0		0 to 20
<input checked="" type="checkbox"/> Extension I/O setting				
Input response time setting	5: 10ms	5: 10ms		
Digital output HOLD/CLEAR setting	0: CLEAR	0: CLEAR		

8. Set "Method selection" to "Parameter write".

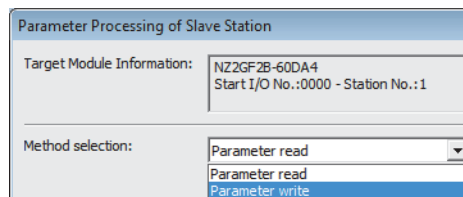

9. Set "Write Value". Follow the next steps to set the value:
- Click the title cell of "Read Value" to select all the items and copy them.
 - Click the title cell of "Write Value" to select all the items and paste the copy.
 - Select the items to be changed, and set new values.

Name	Initial Value	Read Value	Write Value	Setting Range
局単位パラメータ				
<input checked="" type="checkbox"/> Mode switch	9: Automatical judg...	9: Automatical judg...	9: Automatical judg...	
<input checked="" type="checkbox"/> External signal assignment setting				
Trigger output signal assignment	0xFFFF	0xFFFF	0xFFFF	0x0000 to 0xFF...
Alert output signal assignment	0xFFFF	0xFFFF	0xFFFF	0x0000 to 0xFF...
Error flag assignment	0xFFFF	0xFFFF	0xFFFF	0x0000 to 0xFF...
Warning flag assignment	0xFFFF	0xFFFF	0xFFFF	0x0000 to 0xFF...
<input checked="" type="checkbox"/> Cyclic data update watch time setting	0	0		0 to 20
<input checked="" type="checkbox"/> Extension I/O setting				
Input response time setting	5: 10ms	5: 10ms	5: 10ms	
Digital output HOLD/CLEAR setting	0: CLEAR	0: CLEAR	1: HOLD	

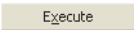
10. Click  button to open the following window.

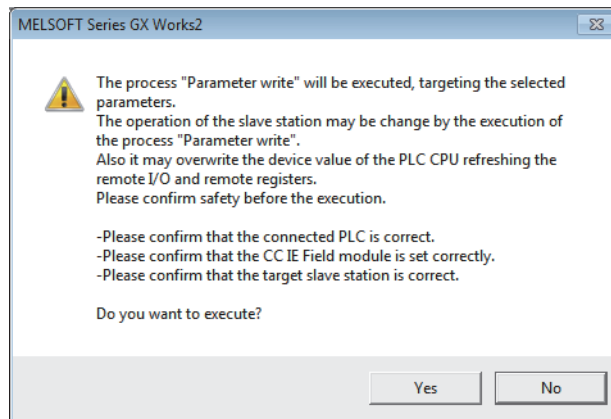

11. Click  button.

12. The parameters are written to the D/A converter module.

Setting the module parameters of the slave station is complete.

7.3 Offset/Gain Setting

If the user range is necessary, set up the offset/gain setting by following the instructions as illustrated below.
 Note that using the factory default range does not require the offset/gain setting.

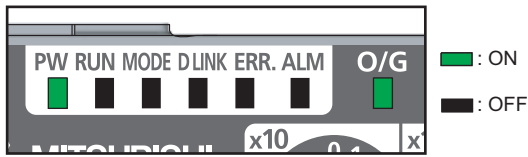
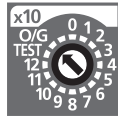

1. Turn off the module power supply.
2. Set x10 of the station number setting switch to O/G.

3. Turn on the module power supply and check that the LEDs are in the following state:
 RUN LED: Off
 O/G LED: On

4. Select the setting target using SET/SEL button.

▲ button ▼ button

[User range setting 1 (-10 to 10V)]

CH1: Offset	V	I	ch1	2	3	4	OFFSET	GAIN
CH1: Gain	V	I	ch1	2	3	4	OFFSET	GAIN
CH2: Offset	V	I	ch1	2	3	4	OFFSET	GAIN
CH2: Gain	V	I	ch1	2	3	4	OFFSET	GAIN
CH3: Offset	V	I	ch1	2	3	4	OFFSET	GAIN
CH3: Gain	V	I	ch1	2	3	4	OFFSET	GAIN
CH4: Offset	V	I	ch1	2	3	4	OFFSET	GAIN
CH4: Gain	V	I	ch1	2	3	4	OFFSET	GAIN

[User range setting 2 (0 to 20mA)]

CH1: Offset	V	I	ch1	2	3	4	OFFSET	GAIN
CH1: Gain	V	I	ch1	2	3	4	OFFSET	GAIN
CH2: Offset	V	I	ch1	2	3	4	OFFSET	GAIN
CH2: Gain	V	I	ch1	2	3	4	OFFSET	GAIN
CH3: Offset	V	I	ch1	2	3	4	OFFSET	GAIN
CH3: Gain	V	I	ch1	2	3	4	OFFSET	GAIN
CH4: Offset	V	I	ch1	2	3	4	OFFSET	GAIN
CH4: Gain	V	I	ch1	2	3	4	OFFSET	GAIN

5. For the selected channel, adjust the analog output value by using the "+" and "-" switches.

Pressing the "+" switch increases the analog output value. Pressing the "-" switch decreases the analog output value.

6. Keep pressing ▲ button until the RUN LED lights up.

Once the RUN LED lights up, release ▲ button.

While the RUN LED lights up, the offset value or gain value is being written to the non-volatile memory.

Upon completion of the write, the RUN LED goes out. Check that the RUN LED goes out, and go to the next step.

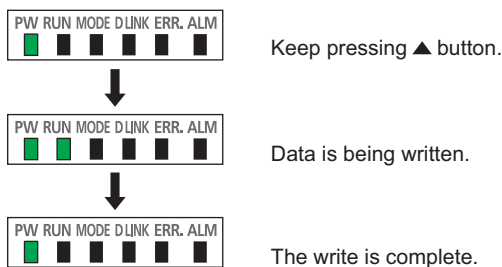

- 7. To set up another channel, go back to step 4.**
- 8. After setting all the channels, turn off the module power supply.**

Point

- Set up the offset value and the gain value under actual use conditions.
Connection to the CC-Link IE Field Network is not necessary.
 - Configure the offset/gain setting in the range satisfying the following condition. If the range is exceeded, the maximum resolution and accuracy may not fall within the range described in the performance specifications.
 - I/O Conversion Characteristics of D/A Conversion ( Page 205, Appendix 4)
 - Set values are held and available even after turning off the module power supply because a offset value and a gain value are written into the non-volatile memory in the main D/A converter module.
 - Set up the offset/gain setting so that the offset value is smaller than the gain value.
With Range setting (address: 0103H) set to User range setting 1 or User range setting 2, the main D/A converter module performs a check on the offset/gain set values when Initial data setting request flag (RY9) is turned on from off. For invalid condition (offset value \geq gain value), this check results in the error code (040□H) being stored into Latest error code (RWr0), Error flag (RXA) turning on, and the ERR. LED lighting up.
 - The extension D/A converter module does not support user range. Therefore, the offset/gain setting cannot be set up for the extension D/A converter module.
-

CHAPTER 8 FUNCTIONS

This chapter describes the details of the functions available in the D/A converter module, and the setting procedures for those functions.

For details on remote I/O signals, remote registers, and remote buffer memory, refer to the following:

- Details of Remote I/O Signals (☞ Page 170, Appendix 1)
- Details of Remote Registers (☞ Page 180, Appendix 2)
- Details of Remote Buffer Memory (☞ Page 185, Appendix 3)

8.1 Mode Shift at Power-On

At power-on, the D/A converter module enters any of the following modes:

- Offset/gain setting mode
- Unit test mode
- Normal mode
- Trigger output mode
- Synchronous communication mode

The conditions of shift to these modes are shown below:

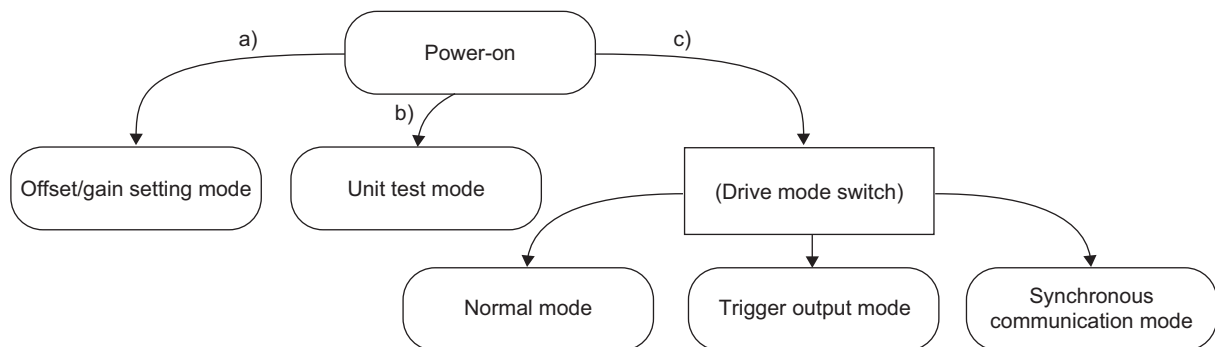

Mark	Mode	Condition
a)	Offset/gain setting mode	If x10 of the station number setting switch is set to O/G, the mode shifts to offset/gain setting mode. For details, refer to the following: • Offset/Gain Setting (☞ Page 83, Section 7.3)
b)	Unit test mode	If x10 of the station number setting switch is set to TEST and x1 of the switch is set to 0, the mode shifts to the unit test mode. For details, refer to the following: • Unit test (☞ Page 166, Section 11.5)
c)	(Drive mode switch)	With the station number setting switch set to 1 to 120, the module enters each drive mode according to the setting of Mode switch (address: 0000H). For details, refer to the following: • Drive Mode Switch (☞ Page 86, Section 8.2)

8.2 Drive Mode Switch

The D/A converter module operates in the following modes: normal mode, trigger output mode, and synchronous communication mode.

The following table lists the types of drive mode and their operation.

Type of drive mode	Operation
Normal mode	D/A conversion is performed based on the internal clock of the main D/A converter module.
Trigger output mode	D/A conversion is performed at the time of turning on Trigger out request (RY19, RY29) from off.
Synchronous communication mode	D/A conversion is performed with a synchronization period of the master station that supports the CC-Link IE Field Network synchronous communication function.

The drive mode can be selected by setting Mode switch (address: 0000H).

(1) Setting procedure

1. Set "Method selection" to "Parameter write".

 "CC IE Field Configuration" window ⇒ Select the main D/A converter module from "List of stations"
⇒ [CC IE Field Configuration] ⇒ [Online] ⇒ [Parameter Processing of Slave Station]

2. In "Station parameter", set "Mode switch" to either "0: Normal output mode", "1: Trigger output mode", or "9: Automatical judgment mode".

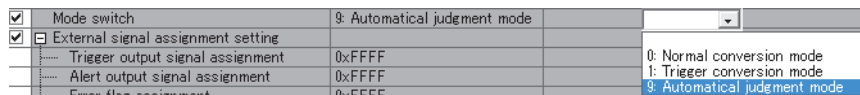

The following table lists the setting value of "Mode switch" and the drive mode.

Setting value of "Mode switch"	Drive mode
"0: Normal conversion mode"	The D/A converter module operates in normal mode.
"1: Trigger output mode"	The D/A converter module operates in trigger output mode.
"9: Automatical judgment mode"	The drive mode is automatically set according to the type of the module that operates as the master station of the D/A converter module.*1

*1 The drive mode varies depending on the module of the master station as shown below.

Master station	Setting of the master station*2	Drive mode when "Mode switch" is set to "9: Automatical judgment mode"
Master/local module (CC-Link IE Field Network synchronous communication function not supported)	—	Normal mode
Master/local module (CC-Link IE Field Network synchronous communication function supported)	Setting the CC-Link IE Field Network synchronous communication function to be disabled	Normal mode
	Setting the CC-Link IE Field Network synchronous communication function to be enabled	Synchronous communication mode
Simple motion module	First five digits of the serial number are 15091 or earlier.	Normal mode
	First five digits of the serial number are 15092 or later.	Synchronous communication mode

*2 For how to set the master station, refer to the MELSEC iQ-R Inter-Module Synchronization Function Reference Manual.

3. Click button to write the parameters to the D/A converter module.

4. Check that "0920H" is stored in Latest warning code (RWr1).

[Online] ⇒ [Monitor] ⇒ [Device/Buffer Memory Batch]

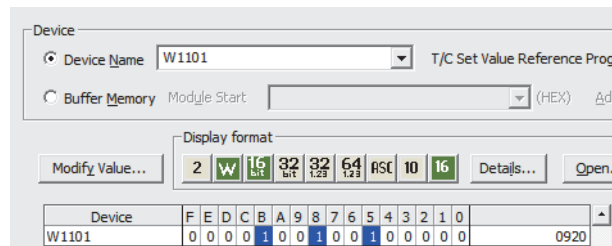

5. The D/A converter module starts operating in the set drive mode by turning off and on the module power supply or performing remote reset.

Point

- For normal mode operation of the D/A converter module connected to a master station that supports the CC-Link IE Field Network synchronous communication function, set to "0: Normal conversion mode".
- In the MELSEC iQ-R series master station, setting each slave station to Synchronous or Asynchronous allows their operation (synchronous communication mode or normal mode) to be managed and configured at a time by the master station. Note, however, that settings for the extension modules have no effect. Their operation follows the settings of the main module connected.

Detect Now											
Mode Setting: Online (Standard Mode) Assignment Method: Start/End Link Scan Time (Approx.): 0.76 ms											
No.	Model Name	STA#	Station Type	RX/RX Setting			RWw/RWr Setting			Reserved/Error Invalid Station	Network Synchronous Communication
				Points	Start	End	Points	Start	End		
0	Host Station	0	Master Station								
1	NZ2GF2B-60AD4	1	Remote Device Station	32	0000	001F	16	0000	000F	No Setting	Synchronous
-	NZ2EX2B-60AD4	-	-	16	0020	002F	16	0010	001F		Asynchronous
2	NZ2GF2B-60DA4	2	Remote Device Station	32	0000	001F	16	0000	000F	No Setting	Synchronous
-	NZ2EX2B-60AD4	-	-	16	0020	002F	16	0010	001F		Asynchronous
3	NZ2GF2B1-16D	3	Remote Device Station	16	0000	000F	20	0000	0013	No Setting	Asynchronous

(2) Drive mode of extension modules

When an extension analog module is connected to a main analog module, the extension analog module operates in the drive mode corresponding to that of the main analog module.

The following table lists the details.

Main analog module	Extension analog module	Drive mode of main analog module	Drive mode of extension analog module
Main A/D converter module	Extension A/D converter module	Normal mode	
		Trigger conversion mode	
		Synchronous communication mode	
	Extension D/A converter module	Normal mode	
		Trigger conversion mode	Trigger output mode
		Synchronous communication mode	
Main D/A converter module	Extension A/D converter module	Normal mode	
		Trigger output mode	Trigger conversion mode
		Synchronous communication mode	
	Extension D/A converter module	Normal mode	
		Trigger output mode	
		Synchronous communication mode	

8.3 D/A Conversion Enable/Disable Function

This function allows D/A conversion to be enabled or disabled for each channel.
Disabling the D/A conversion for unused channels reduces the conversion cycles.

(1) Setting procedure

The setting procedure for the main D/A converter module is as follows:

1. Set "Method selection" to "Parameter write".

 "CC IE Field Configuration" window ⇒ Select the main D/A converter module from "List of stations"
⇒ [CC IE Field Configuration] ⇒ [Online] ⇒ [Parameter Processing of Slave Station]

2. In "Basic module parameter", set "CH□ D/A conversion enable/disable setting" to either "0: Enable" or "1: Disable".

<input checked="" type="checkbox"/>	D/A conversion enable/disable setting			
<input type="checkbox"/>	CH1 D/A conversion enable/disable setting	1: Disable		
<input type="checkbox"/>	CH2 D/A conversion enable/disable setting	1: Disable		
<input type="checkbox"/>	CH3 D/A conversion enable/disable setting	1: Disable	0: Enable	
<input type="checkbox"/>	CH4 D/A conversion enable/disable setting	1: Disable	1: Disable	

Point

For the extension D/A converter module, go to "Ext. module 1_Module parameter", and make the setting of "Ext. module 1_CH□ D/A conversion enable/disable setting".

8.4 D/A Output Enable/Disable Function

This function allows the selection of whether to output the D/A conversion value or the offset value for each channel.
Whether the output is enabled or disabled, the conversion period is constant.

(1) Setting method

Use CH□ Output enable/disable flag (RY10 to RY13, RY20 to RY23) for the setting.

CH□ Output enable/disable flag (RY10 to RY13, RY20 to RY23)	Analog output
Output enable (ON)	The D/A conversion value is output.
Output disable (OFF)	The offset value is output.

8.5 Conversion Speed and Conversion Period

Conversion speed is the rate at which the D/A converter module converts and outputs digital values.

The conversion period is the period for D/A conversion in a channel.

The following figure shows the relationship between conversion speed and a conversion period.

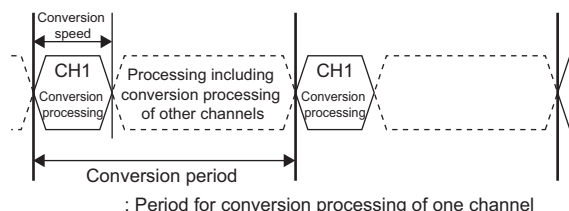

The conversion period varies depending on the type of main analog module, the conversion speed, the type of extension module, and the number of conversion enabled channels.

The following table shows the classification.

Main analog module	Extension module	Conversion speed setting	Conversion period ^{*1}	Reference
Main D/A converter module	<ul style="list-style-type: none"> Not connected Extension I/O module 	–	$100\mu\text{s} \times \text{Number of conversion enabled channels}$	Page 89, Section 8.5 (1)
	Extension D/A converter module	–	$200\mu\text{s} \times \text{Number of conversion enabled channels}$	Page 90, Section 8.5 (2)
	Extension A/D converter module	–	$200\mu\text{s} \times \text{Number of conversion enabled channels}$	Page 91, Section 8.5 (3)
Main A/D converter module	<ul style="list-style-type: none"> Not connected Extension I/O module 	<ul style="list-style-type: none"> 100μs 400μs 1ms 	Conversion speed \times Number of conversion enabled channels	*2
	Extension A/D converter module	100 μs	$200\mu\text{s} \times \text{Number of conversion enabled channels}$	
		400 μs	$500\mu\text{s} \times \text{Number of conversion enabled channels}$	
		1ms	$1\text{ms} \times \text{Number of conversion enabled channels}$	
Extension D/A converter module	<ul style="list-style-type: none"> 100μs 400μs 1ms 	$200\mu\text{s} \times \text{Number of conversion enabled channels}$	Page 91, Section 8.5 (4)	

*1 For an A/D converter module, this column corresponds to the sampling period.

*2 For details, refer to the following:

- CC-Link IE Field Network Analog-Digital Converter Module User's Manual

(1) When an extension module is not connected or an extension I/O module is connected

The conversion speed is 100 μs /channel. The conversion period is given by the following:

Conversion period = Conversion speed (100 μs) \times Number of conversion enabled channels

Ex. Assuming that the number of conversion enabled channels is 4

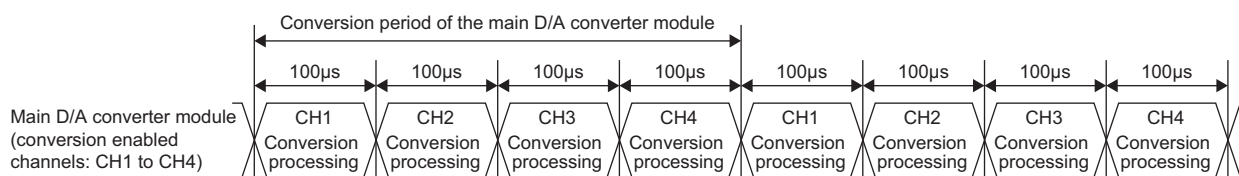

$$\text{Conversion period} = 100\mu\text{s} \times 4 = 400\mu\text{s}$$

(2) When an extension D/A converter module is connected to a main D/A converter module

converter module

When an extension D/A converter module is connected to a main D/A converter module, processing time (100μs) arises between the conversion processing of each channel. Therefore, the conversion period is given by the following:

Conversion period = (Conversion speed (100μs) + Processing time (100μs)) × Number of conversion enabled channels

Ex. Assuming that the number of conversion enabled channels is 4 for both the main D/A converter module and the extension D/A converter module

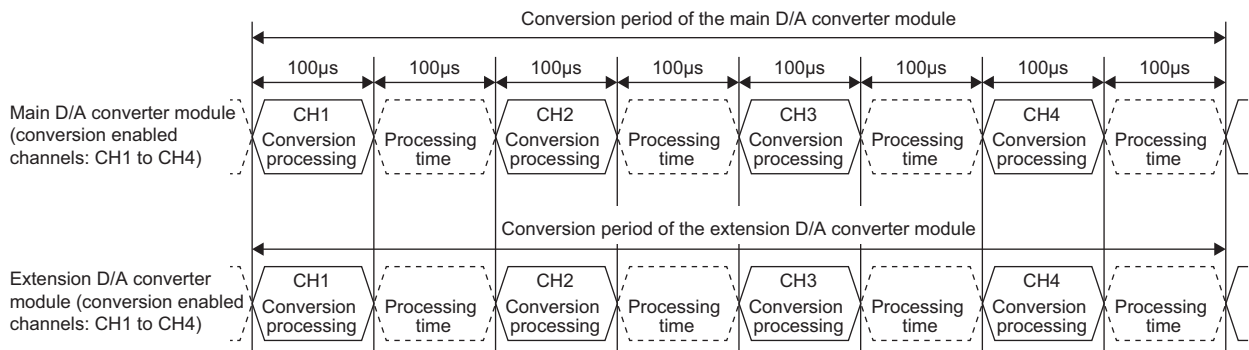

Conversion period of the main D/A converter module = $(100\mu\text{s} + 100\mu\text{s}) \times 4 = 800\mu\text{s}$

Conversion period of the extension D/A converter module = $(100\mu\text{s} + 100\mu\text{s}) \times 4 = 800\mu\text{s}$

Point

If the number of conversion enabled channels is different between a main D/A converter module and an extension D/A converter module, the main D/A converter module and the extension D/A converter module perform D/A conversion at each different conversion period.

For example, assuming the following settings:

- Conversion enabled channels of the main D/A converter module: CH1, CH2, CH3 (number of conversion enabled channels: 3)
- Conversion enabled channels of the extension D/A converter module: CH1, CH2 (number of conversion enabled channels: 2)

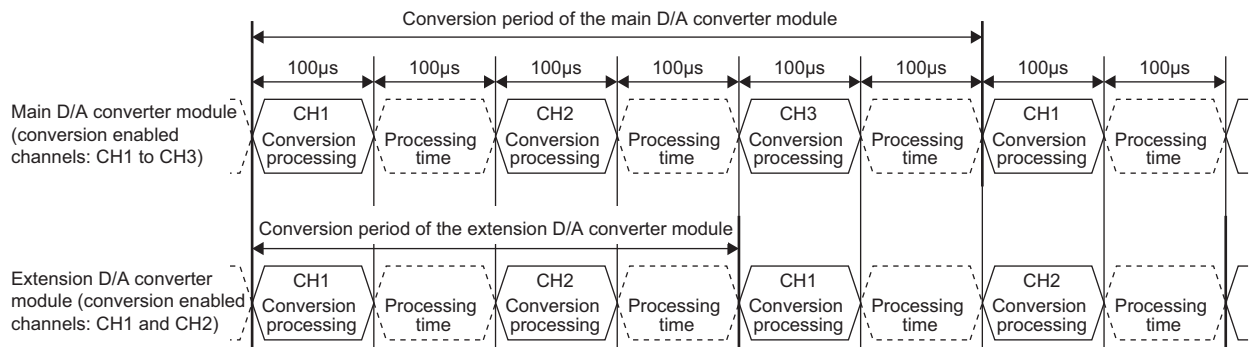

Conversion period of the main D/A converter module = $(\text{Conversion speed } (100\mu\text{s}) + \text{Processing time } (100\mu\text{s})) \times 3 = 600\mu\text{s}$

Conversion period of the extension D/A converter module = $(\text{Conversion speed } (100\mu\text{s}) + \text{Processing time } (100\mu\text{s})) \times 2 = 400\mu\text{s}$

(3) When an extension A/D converter module is connected to a main D/A converter module

When an extension A/D converter module is connected to a main D/A converter module, the conversion speed is fixed to 100 μ s for the main D/A converter module and the extension A/D converter module. In addition, processing time (100 μ s) arises between the conversion processing of each channel. Therefore, the conversion period of the main D/A converter module is given by the following:

Conversion period = (Conversion speed (100 μ s) + Processing time (100 μ s)) \times Number of conversion enabled channels

Ex. Assuming that the number of conversion enabled channels is 4 for both the main D/A converter module and the extension A/D converter module

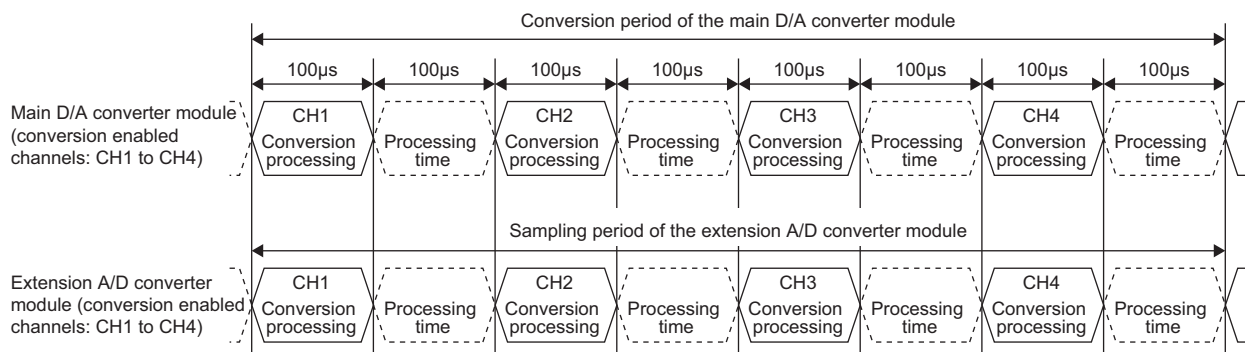

Conversion period of the main D/A converter module = (100 μ s + 100 μ s) \times 4 = 800 μ s

Sampling period of the extension A/D converter module = (100 μ s + 100 μ s) \times 4 = 800 μ s

(4) When an extension D/A converter module is connected to a main A/D converter module

When an extension D/A converter module is connected to a main A/D converter module, the conversion speed is fixed to 100 μ s. The setting of the conversion speed switch (address: 0001H) is ignored. In addition, processing time (100 μ s) arises between the conversion processing of each channel.

Therefore, the conversion period of the extension D/A converter module is given by the following:

Conversion period = (Conversion speed (100 μ s) + Processing time (100 μ s)) \times Number of conversion enabled channels

Ex. Assuming that the number of conversion enabled channels is 4 for both the main A/D converter module and the extension D/A converter module

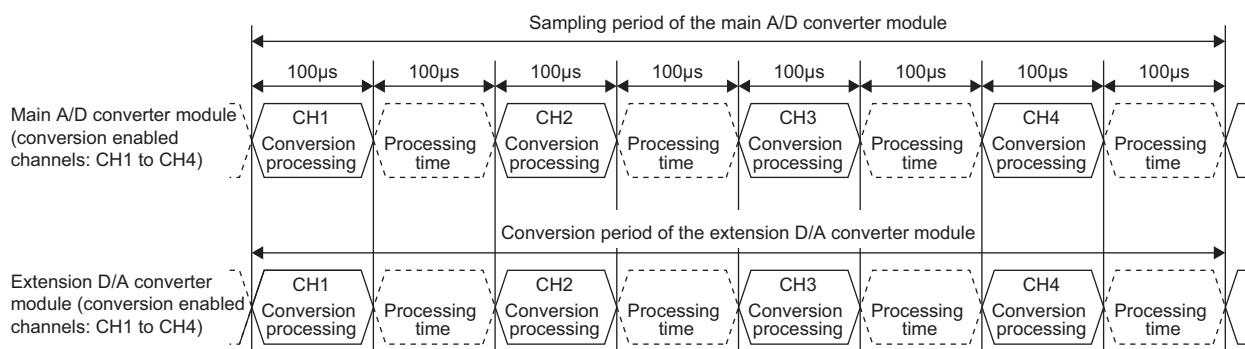

Sampling period of the main A/D converter module = (100 μ s + 100 μ s) \times 4 = 800 μ s

Conversion period of the extension D/A converter module = (100 μ s + 100 μ s) \times 4 = 800 μ s

8.6 Range Switching Function

The output range can be selected for each channel from the following ranges:

- Factory default range (4 to 20mA, 0 to 20mA, 1 to 5V, 0 to 5V, -10 to 10V)
- User range (user range setting 1 (-10 to 10V), user range setting 2 (0 to 20mA))*¹

*1 The main D/A converter module only permits the selection.

(1) Setting procedure

The setting procedure for the main D/A converter module is as follows:

1. Set "Method selection" to "Parameter write".

 "CC IE Field Configuration" window ⇒ Select the main D/A converter module from "List of stations"
⇒ [CC IE Field Configuration] ⇒ [Online] ⇒ [Parameter Processing of Slave Station]

2. In "Basic module parameter", set "CH□ D/A conversion enable/disable setting" to "0: Enable".

<input checked="" type="checkbox"/>	D/A conversion enable/disable setting			
	CH1 D/A conversion enable/disable setting	1: Disable		
	CH2 D/A conversion enable/disable setting	1: Disable		
	CH3 D/A conversion enable/disable setting	1: Disable	0: Enable	
	CH4 D/A conversion enable/disable setting	1: Disable	1: Disable	

3. In "Basic module parameter", set up "CH□ Range setting".

<input checked="" type="checkbox"/>	Range setting			
	CH1 Range setting	0: 4 to 20mA		
	CH2 Range setting	0: 4 to 20mA		
	CH3 Range setting	0: 4 to 20mA	0: 4 to 20mA	
	CH4 Range setting	0: 4 to 20mA	1: 0 to 20mA	
<input checked="" type="checkbox"/>	Analog output HOLD/CLEAR ...			
	CH1 Analog output HOLD/...	0: CLEAR	2: 1 to 5V	
	CH2 Analog output HOLD/...	0: CLEAR	3: 0 to 5V	
	CH3 Analog output HOLD/...	0: CLEAR	4: -10 to 10V	
	CH4 Analog output HOLD/...	0: CLEAR	5: User range setting 1 (-10 to 10V)	
			6: User range setting 2 (0 to 20mA)	

Point

- When "CH□ D/A conversion enable/disable setting" is set to "1: Disable", the range is not changed. To change the output range, set "CH□ D/A conversion enable/disable setting" to "0: Enable" and CH□ Output enable/disable flag (RY10 to RY13, RY20 to RY23) to Disable (OFF), and then set a value (within the range an external device allows) for CH□ Digital value (RWw2 to RWw5, RWw12 to RWw15).

For example, when the output range is from 0 to 5V and CH□ Digital value (RWw2 to RWw5, RWw12 to RWw15) is 12000, 5V is output. In this condition, if the output range is changed to -10 to 10V, 7.5V is output because CH□ Digital value (RWw2 to RWw5, RWw12 to RWw15) remains 12000.

- For the extension D/A converter module, make the settings for each item of "Ext. module 1_Module parameter".

8.7 Analog Output HOLD/CLEAR Function

This function allows the selection of whether to hold or clear the analog value output when the CPU module is in the following operating status: RUN, STOP, or a stop error.

(1) Combination of analog output status

The following table shows how the analog output status changes, depending on the combination of settings for D/A conversion enable/disable setting (address: 0102H, 0202H) and CH□ Output enable/disable flag (RY10 to RY13, RY20 to RY23).

Execution status	D/A conversion enable/disable setting (address: 0102H, 0202H)	Enable		Disable
	CH□ Output enable/disable flag (RY10 to RY13, RY20 to RY23)	Enable		Disable
	Analog output HOLD/CLEAR setting (address: 0104H, 0204H)	HOLD	CLEAR	HOLD or CLEAR
Analog output status while the CPU module is in RUN	The analog value D/A-converted from the digital value is output.		Offset value	0V/0mA
Analog output status while the CPU module is in STOP	Hold	Offset value	Offset value	0V/0mA
Analog output status while the CPU module is in stop error	Hold	Offset value	Offset value	0V/0mA
Analog output status while the D LINK LED is off ^{*2}	Hold	Offset value	Offset value	0V/0mA
Analog output status while the instruction of data link stop is received from the master station	Hold	Offset value	Offset value	0V/0mA
Analog output status while reserved from the master station	Hold	Offset value	Offset value	0V/0mA
Analog output status of when the out-of-range digital value error occurs	The upper limit value or lower limit value of analog value is output.		Offset value	0V/0mA
Analog output status of when the out-of-range setting error occurs	0V/0mA	0V/0mA	0V/0mA	0V/0mA
Analog output status of when a hardware failure ^{*1} occurs	0V/0mA	0V/0mA	0V/0mA	0V/0mA
Analog output status of when an error related to synchronous communication ^{*3} has occurred	Hold	Offset value	Offset value	0V/0mA

*1 Indicates the case that the operation of a program is not completed within the expected time in the CPU module due to a hardware failure in the D/A converter module or other factors. In this case, Remote READY (RXB) turns off and the RUN LED of the D/A converter module goes out.

*2 The analog output HOLD/CLEAR function may be executed even when the D LINK LED is on if the cyclic data update watch time is set. For details, refer to the following:
Cyclic Data Update Watch Function (📄 Page 95, Section 8.8)

*3 The error related to synchronous communication includes the following errors.

- RWw/RWr setting error (error code: 0E00H)
- Synchronous communication error 1 (error code: 0E10H)
- Synchronization cycle setting error (error code: 0E20H)
- Synchronous communication error 2 (error code: 0E30H)

(2) Setting procedure

The setting procedure for the main D/A converter module is as follows:

1. Set "Method selection" to "Parameter write".

 "CC IE Field Configuration" window ⇒ Select the main D/A converter module from "List of stations"
⇒ [CC IE Field Configuration] ⇒ [Online] ⇒ [Parameter Processing of Slave Station]

2. In "Basic module parameter", set "CH□ D/A conversion enable/disable setting" to "0: Enable".

<input checked="" type="checkbox"/>	D/A conversion enable/disable setting			
 CH1 D/A conversion enable/disable setting	1: Disable		
 CH2 D/A conversion enable/disable setting	1: Disable		
 CH3 D/A conversion enable/disable setting	1: Disable	0: Enable	
 CH4 D/A conversion enable/disable setting	1: Disable	1: Disable	

3. In "Basic module parameter", set up "CH□ Analog output HOLD/CLEAR setting".

<input checked="" type="checkbox"/>	Analog output HOLD/CLEAR setting			
 CH1 Analog output HOLD/CLEAR setting	0: CLEAR		
 CH2 Analog output HOLD/CLEAR setting	0: CLEAR		
 CH3 Analog output HOLD/CLEAR setting	0: CLEAR	0: CLEAR	
 CH4 Analog output HOLD/CLEAR setting	0: CLEAR	1: HOLD	



For the extension D/A converter module, make the settings for each item of "Ext. module 1_Module parameter".

8.8 Cyclic Data Update Watch Function

The update intervals of cyclic data are monitored. The last output value is held or cleared when the cyclic transmission stop status continues longer than the set monitoring time.

The cyclic transmission stop status is the status that the D LINK LED is flashing (Data link in operation (cyclic transmission stopped)) or off (Data link not performed (disconnected)).

Set whether to hold or clear the output value using the digital output HOLD/CLEAR setting function and the analog output HOLD/CLEAR setting function.

For the digital output HOLD/CLEAR setting function, refer to the following:

- Digital output HOLD/CLEAR setting function (☞ Page 129, Section 8.16)

For the analog output HOLD/CLEAR setting function, refer to the following:

- Analog output HOLD/CLEAR setting function (☞ Page 93, Section 8.7)

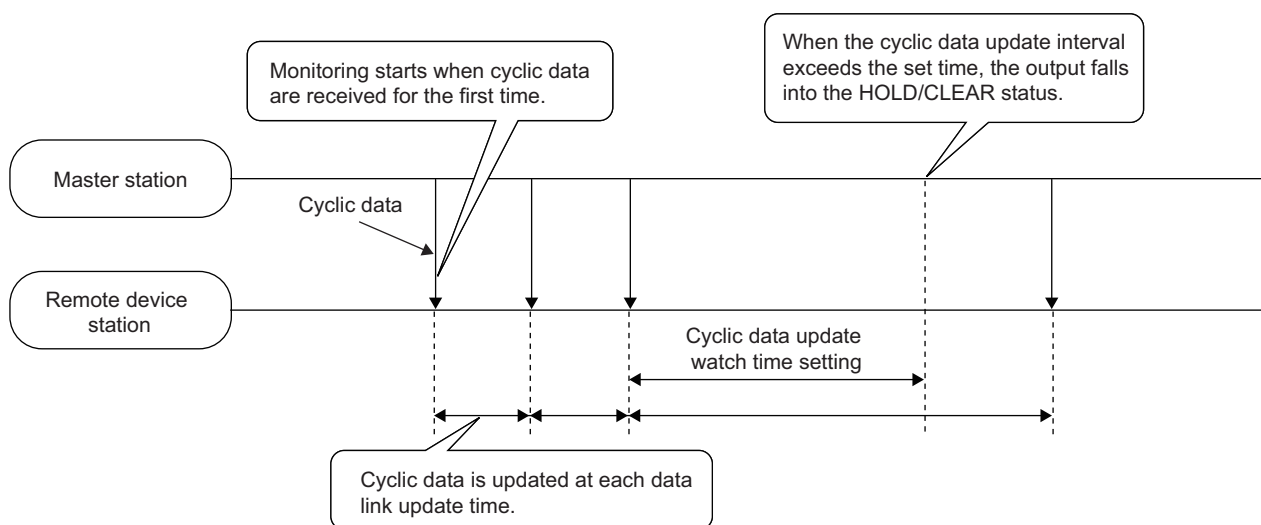

(1) Setting procedure

1. Set "Method selection" to "Parameter write".

☞ "CC IE Field Configuration" window ⇒ Select the main D/A converter module from "List of stations" ⇒ [CC IE Field Configuration] ⇒ [Online] ⇒ [Parameter Processing of Slave Station]

2. In "Station parameter", set the monitoring time for "Cyclic data update watch time setting".

Cyclic data update watch time setting 0

Item	Setting range
Cyclic data update watch time setting	<ul style="list-style-type: none"> • 0 (Not monitor) • 1 to 20 (0.1 to 2 seconds in units of 100ms)

Point

- For the cyclic data update watch time setting, set a greater value than the link scan time.
- Under operation in synchronous communication mode, the setting of Cyclic data update watch time setting is ignored.

8.9 Scaling Function

The D/A converter module scale-converts the digital value to the set range of the scaling upper limit value and scaling lower limit value. This function reduces the time and effort to create a program of the scale conversion.

(1) How to interpret the scaling setting

The setting for scaling lower and upper limit values differs depending on whether the factory default range or the user range is used for the analog output range.

(a) When the factory default range is used for the analog output range

- Set a value corresponding to the upper limit value of the analog output value in the range setting for the scaling upper limit value.
- Set a value corresponding to the lower limit value of the analog output value in the range setting for the scaling lower limit value.

(b) When the user range is used for the analog output range

- Set a value corresponding to the gain value for the scaling upper limit value.
- Set a value corresponding to the offset value for the scaling lower limit value.

(2) Calculation of the scaling value

Scale conversion is performed on the digital values using the following formula:

(Values after the decimal point are rounded down during scale conversion.)

- When the output range is 4 to 20mA, 0 to 20mA, 1 to 5V, or 0 to 5V, user range setting 1 (-10 to 10V), or user range setting 2 (0 to 20mA)

$$\text{Digital value used for D/A conversion} = \frac{12000}{S_H - S_L} \times (D_x - S_L)$$

- When the output range is -10 to 10V

$$\text{Digital value used for D/A conversion} = \frac{32000}{S_H - S_L} \times (D_x - S_L) - 16000$$

Item	Description
D _x	Digital value
S _H	Scaling upper limit value
S _L	Scaling lower limit value

(3) Setting procedure

The setting procedure for the main D/A converter module is as follows:

1. Set "Method selection" to "Parameter write".

 "CC IE Field Configuration" window ⇒ Select the main D/A converter module from "List of stations"
⇒ [CC IE Field Configuration] ⇒ [Online] ⇒ [Parameter Processing of Slave Station]

2. In "Basic module parameter", set "CH□ D/A conversion enable/disable setting" to "0: Enable".

<input checked="" type="checkbox"/>	D/A conversion enable/disable setting			
 CH1 D/A conversion enable/disable setting	1: Disable		
 CH2 D/A conversion enable/disable setting	1: Disable		
 CH3 D/A conversion enable/disable setting	1: Disable		0: Enable
 CH4 D/A conversion enable/disable setting	1: Disable		1: Disable

3. In "Basic module parameter", set "CH□ Scaling enable/disable setting" to "0: Enable".

<input checked="" type="checkbox"/>	Scaling function			
 CH1 Scaling enable/disable setting	1: Disable		
 CH1 Scaling upper limit value	0		
 CH1 Scaling lower limit value	0		0: Enable
 CH2 Scaling enable/disable setting	1: Disable		1: Disable

4. In "Basic module parameter", set the values for "CH□ Scaling lower limit value" and "CH□ Scaling upper limit value".

<input checked="" type="checkbox"/>	Scaling function			
 CH1 Scaling enable/disable setting	1: Disable		0: Enable
 CH1 Scaling upper limit value	0		10000
 CH1 Scaling lower limit value	0		4000

Item	Setting range
CH□ Scaling upper limit value	-32000 to 32000
CH□ Scaling lower limit value	

Point

- Even if the scaling upper limit value and the scaling lower limit value are set so that the change is larger than the maximum resolution described in the performance specifications, the resolution will not increase.
- Scaling settings must meet the following condition:
Scaling upper limit value > Scaling lower limit value
- For the extension D/A converter module, make the settings for each item of "Ext. module 1_Module parameter".

(4) Example of the scaling setting

Ex. 1: When values are set for a channel with output range of 0 to 5V in the main D/A converter module as follows:

- "CH□ Scaling enable/disable setting": "0: Enable"
- "CH□ Scaling upper limit value": 10000
- "CH□ Scaling lower limit value": 2000

<input checked="" type="checkbox"/>	Scaling function		
	CH1 Scaling enable/disable setting	1: Disable	0: Enable
	CH1 Scaling upper limit value	0	10000
	CH1 Scaling lower limit value	0	2000

The digital values and scale-converted digital values are as follows:

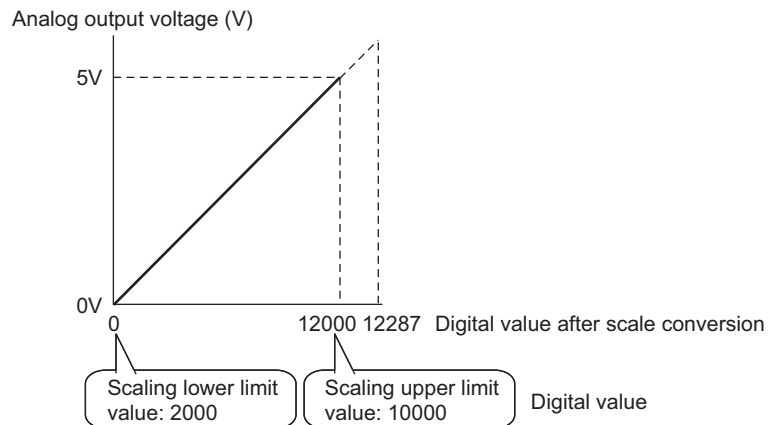

Digital value	Digital value after scale conversion	Analog output voltage (V)
2000	0	0
3600	2400	1
5200	4800	2
6800	7200	3
8400	9600	4
10000	12000	5

Ex. 2: When values are set for a channel with output range of -10V to 10V in the main D/A converter module as follows:

- "CH□ Scaling enable/disable setting": "0: Enable"
- "CH□ Scaling upper limit value": 12000
- "CH□ Scaling lower limit value": 4000

<input checked="" type="checkbox"/>	Scaling function		
	CH1 Scaling enable/disable setting	1: Disable	0: Enable
	CH1 Scaling upper limit value	0	10000
	CH1 Scaling lower limit value	0	4000

The digital values and scale-converted digital values are as follows:

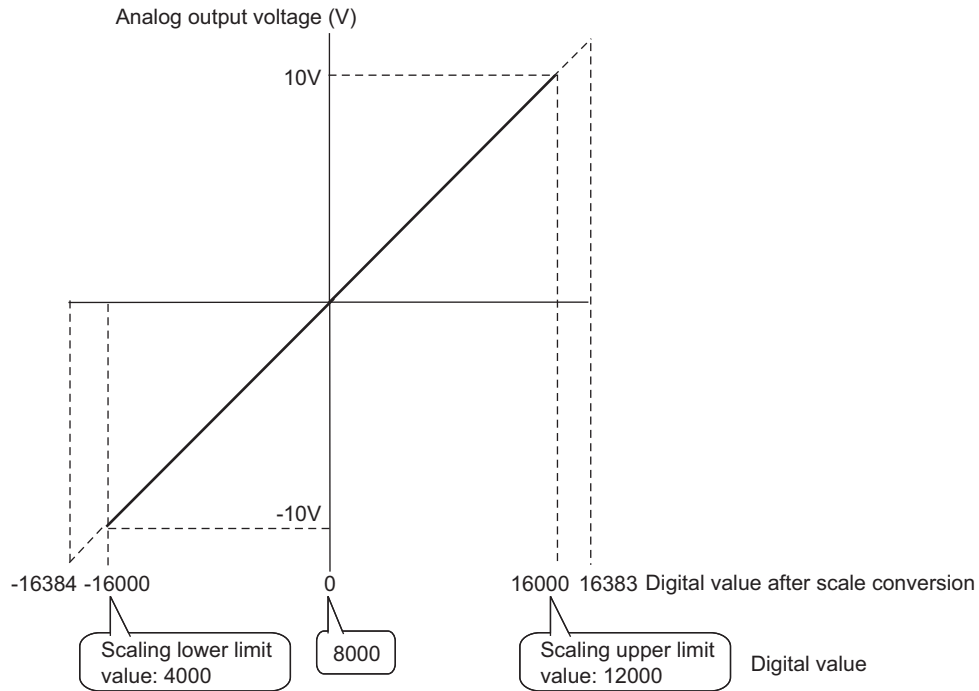

Digital value	Digital value after scale conversion	Analog output voltage (V)
4000	-16000	-10
6000	-8000	-5
8000	0	0
10000	8000	5
12000	16000	10

Ex. 3: When values are set for a channel with user range setting 1 of 2 to 10V in the main D/A converter module as follows:

- "CH□ Scaling enable/disable setting": "0: Enable"
- "CH□ Scaling upper limit value": 8000
- "CH□ Scaling lower limit value": 2000

<input checked="" type="checkbox"/>	Scaling function			
<input type="checkbox"/>	CH1 Scaling enable/disable setting	1: Disable		0: Enable
<input type="checkbox"/>	CH1 Scaling upper limit value	0		8000
<input type="checkbox"/>	CH1 Scaling lower limit value	0		2000

The digital values and scale-converted digital values are as follows:

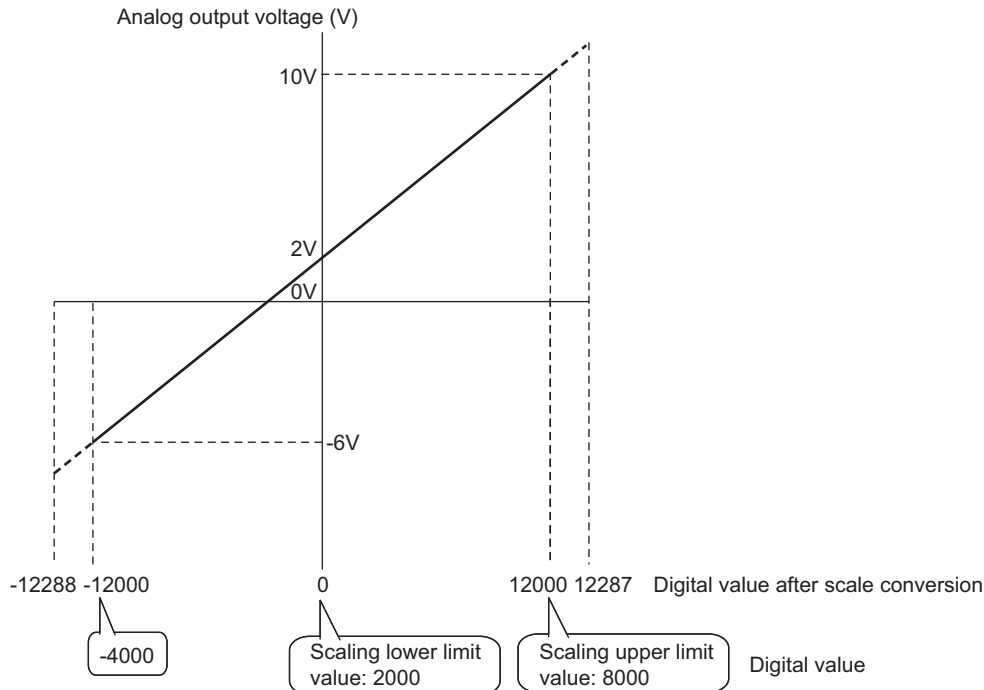

Digital value	Digital value after scale conversion	Analog output voltage (V)
-4000	-12000	-6
-1000	-6000	-2
2000	0	2
5000	6000	6
8000	12000	10

Point

- When using the scaling function, the digital value before scaling can be set to a value out of the range of the scaling upper and lower limit values (dotted line area in the I/O characteristics). However, use the scaling function within the range of the analog output practical range (solid line area in the I/O characteristics). If the value is out of the analog output practical range, the maximum resolution and accuracy may not fall within the range of performance specifications.
- The default digital value "0" may not be appropriate depending on the scaling function setting. Especially in the examples 1, 2, and 3, the out-of-range digital value error (error code: 060□H, 160□H) occurs if CH□ Output enable/disable flag (RY10 to RY13, RY20 to RY23) is turned on with the digital value being "0". Therefore, set an appropriate digital value within the scaling range before turning on CH□ Output enable/disable flag (RY10 to RY13, RY20 to RY23).
- When using the user range, note that the scaling lower limit value is equal to the offset value.

8.10 Shift Function

Using this function, the D/A converter module outputs the converted digital value with the shifting set value added, in analog.

When the shifting set value is changed, it is reflected to the analog output value in real time. Therefore, fine adjustment can be easily performed when the system starts.

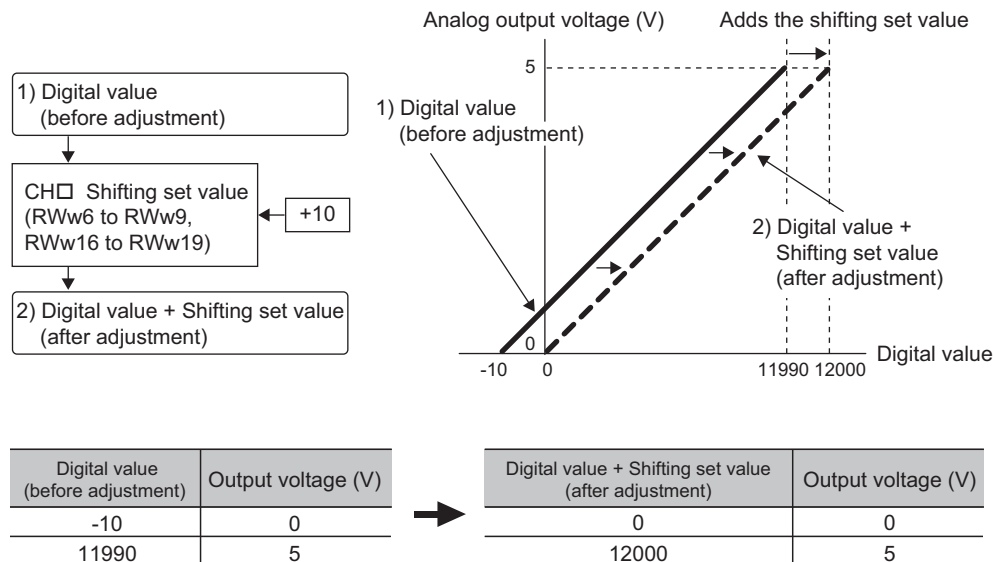

(1) How the shift function operates

The shifting set value is added to a digital value, and the added digital value is output in analog. When the scaling function is used, the scale conversion is executed after the addition by the shift function. By default, the shifting set value is "0". If some value is set to the shifting set value, the shifting set value is added regardless of the status change (OFF→ON→OFF) of Initial data setting request flag (RY9).

(2) Setting procedure

The setting procedure for the main D/A converter module is as follows:

1. Set "Method selection" to "Parameter write".

☞ "CC IE Field Configuration" window ⇒ Select the main D/A converter module from "List of stations" ⇒ [CC IE Field Configuration] ⇒ [Online] ⇒ [Parameter Processing of Slave Station]

2. Set "CH□ D/A conversion enable/disable setting" to "0: Enable".

<input checked="" type="checkbox"/>	D/A conversion enable/disable setting			
<input type="checkbox"/>	CH1 D/A conversion enable/disable setting	1: Disable		
<input type="checkbox"/>	CH2 D/A conversion enable/disable setting	1: Disable		
<input type="checkbox"/>	CH3 D/A conversion enable/disable setting	1: Disable		0: Enable
<input type="checkbox"/>	CH4 D/A conversion enable/disable setting	1: Disable		1: Disable

3. Set a value for CH□ Shifting set value (RWw6 to RWw9).

By default, the shifting set value is "0".

Item	Setting range
CH□ Shifting set value (RWw6 to RWw9)	-32768 to 32767

- If the digital value exceeds the range of -32768 to 32767 as a result of shift addition, the digital operation value is fixed to the lower limit value (-32768) or the upper limit value (32767).
- For the extension D/A converter module, go to "Ext. module 1_Module parameter" to set "Ext. module 1_CH□ D/A conversion enable/disable setting" to "0: Enable", and set a value to be added in CH□ Shifting set value (RWw16 to RWw19) of the extension D/A converter module.

(3) Setting example

Ex. When values are set for a channel with output range of -10 to 10V in the main D/A converter module as follows:

- CH□ Shifting set value (RWw6 to RWw9): 250

The digital value is as follows:

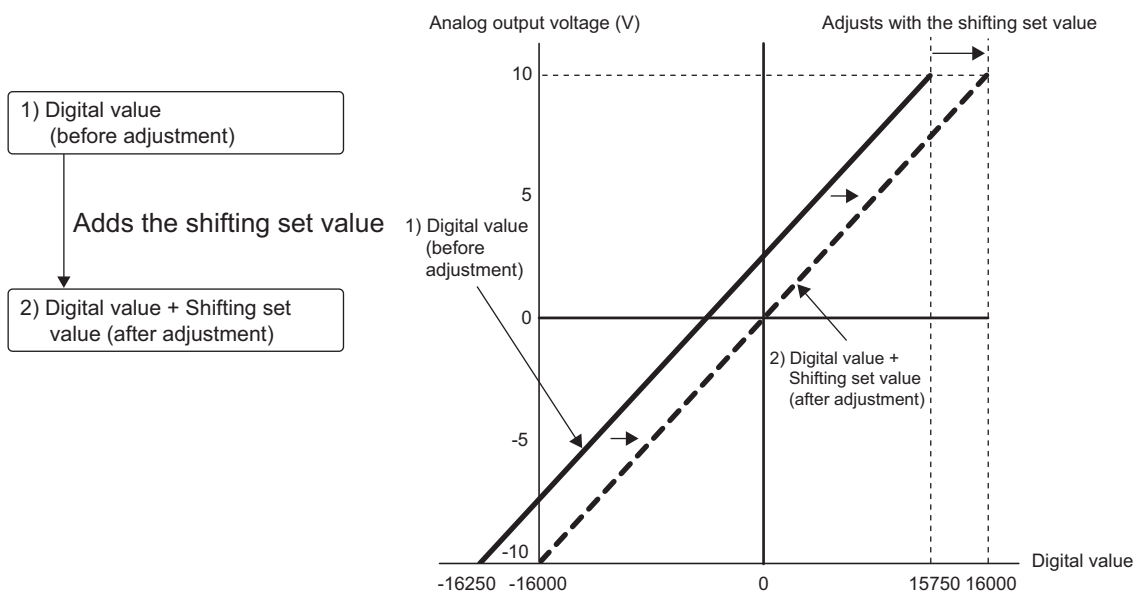

Analog output voltage (V)	Digital value (before adjustment)	Digital value + Shifting set value (after adjustment)
-10	-16250	-16000
-5	-8250	-8000
0	-250	0
5	7750	8000
10	15750	16000

(4) Example of the combined use of the scaling function and the shift function

Ex. When values are set for a channel with output range of 0 to 5V in the main D/A converter module as follows:

- "CH□ Scaling enable/disable setting": "0: Enable"
- "CH□ Scaling upper limit value": 9000
- "CH□ Scaling lower limit value": 3000
- "CH□ Shifting set value (RWw6 to RWw9)": -25

The digital value is as follows:

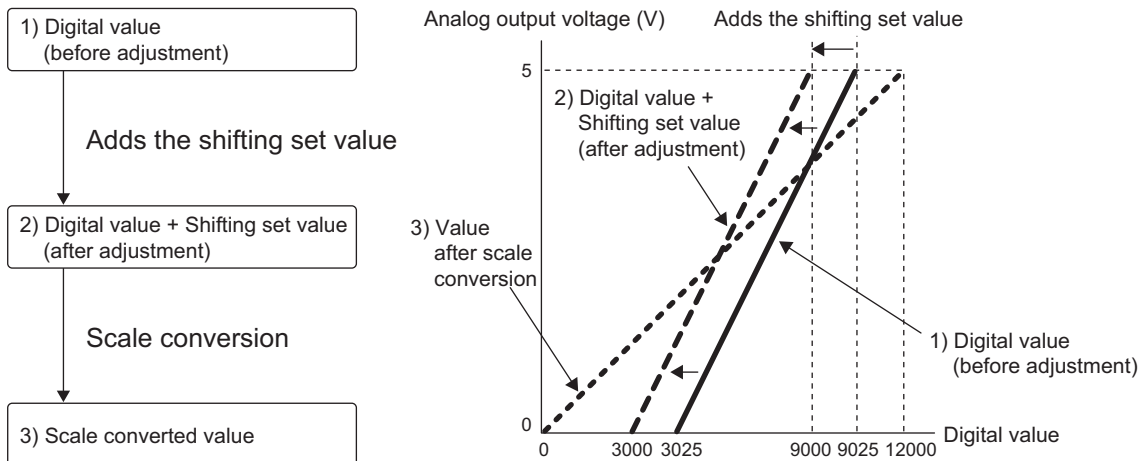

Analog output voltage (V)	Digital value	Digital value + Shifting set value	Value after scaling
0	3025	3000	0
1	4225	4200	2400
2	5425	5400	4800
3	6625	6600	7200
4	7825	7800	9600
5	9025	9000	12000

1. Set "Method selection" to "Parameter write".

☞ "CC IE Field Configuration" window ⇒ Select the main D/A converter module from "List of stations" ⇒ [CC IE Field Configuration] ⇒ [Online] ⇒ [Parameter Processing of Slave Station]

2. In "Basic module parameter", set "CH□ D/A conversion enable/disable setting" to "0: Enable".

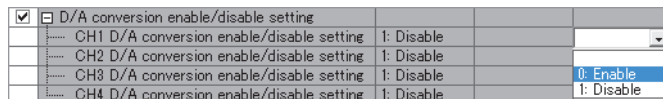

3. In "Basic module parameter", set "CH□ Scaling enable/disable setting" to "0: Enable".

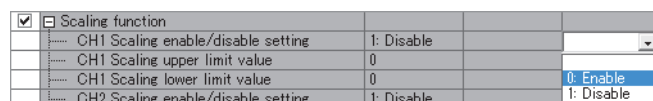

4. In "Basic module parameter", set the values for "CH□ Scaling lower limit value" and "CH□ Scaling upper limit value".

<input checked="" type="checkbox"/>	Scaling function			
	CH1 Scaling enable/disable setting	1: Disable		0: Enable
	CH1 Scaling upper limit value	0		9000
	CH1 Scaling lower limit value	0		3000

5. Set "CH□ Shifting set value (RWw6 to RWw9)" to -25.

8.11 Digital Value Range Check Function

An error is output when the digital value is out of the digital input range for the output range.

(1) Notification of a check code

When the digital value is greater than the upper limit of the setting range or smaller than the lower limit of the setting range, it is notified with the following operation.

- The check code is stored in CH□ Set value check code (RWr2 to RWr5, RWr12 to RWr15).

For details on the check codes, refer to the following:

☞ Page 181, Appendix 2 (3)

- Digital value outside the range (060□H or 160□H) is stored in Latest warning code (RWr1).
- Warning flag (RX7) turns ON.
- The ALM LED of the main module flashes.

For the setting range for the digital value, refer to the following:

Output range setting	When the scaling function is disabled		When the scaling function is enabled*1
	Setting range (Actual range)	Digital value when a value out of the setting range is written	Setting range
4 to 20mA	-288 to 12287 (Actual range: 0 to 12000)	12288 or more: 12287 -289 or less: -288	-32768 to 32767 (Maximum actual range: -32000 to 32000)
0 to 20mA			
1 to 5V			
0 to 5V			
-10 to 10V	-16384 to 16383 (Actual range: -16000 to 16000)	16384 or more: 16383 -16385 or less: -16384	
User range setting 1 (-10 to 10V)*2	-12288 to 12287 (Actual range: -12000 to 12000)	12288 or more: 12287 -12289 or less: -12288	
User range setting 2 (0 to 20mA)*2	-288 to 12287 (Actual range: 0 to 12000)	12288 or more: 12287 -289 or less: -288	

*1 The setting range and the actual range of when the scaling function is enabled depend on the settings in the scaling upper limit value and the scaling lower limit value.

*2 This range can be selected only with the main D/A converter module.

(2) Operation of when an error is notified with a check code

When the digital value is greater than the upper limit of the setting range or smaller than the lower limit of the setting range, analog output is as follows:

- When the digital value is greater than the upper limit of the setting range, the analog value is output with the upper limit of the setting range.
- When the digital value is smaller than the lower limit of the setting range, the analog value is output with the lower limit of the setting range.

The analog output value returns to the normal value when the digital value falls within the setting range. However, the indicated notification remains as follows:

- Once a check code is stored, it is not reset automatically.
- Warning flag (RX7) remains ON.
- The ALM LED of the main module remains flashing.

(3) Resetting a check code

The check codes can be reset by either of the following two methods.

- Write a digital value within the setting range, and turn on and off Error clear request flag (RYA).
- Turn on and off Initial data setting request flag (RY9).

(4) When the scaling function is enabled

When Scaling enable/disable setting (address: 010EH, 020EH) is set to Enable (0), the scale-converted digital value is the target for the check code.

Point

When the scale-converted digital value is out of the setting range, a slight inaccuracy may be contained in the target digital value for the check code when the check code is stored due to an operational error in the scale conversion.

(5) When the shift function is enabled

When a value is set for CH□ Shifting set value (RWw6 to RWw9, RWw16 to RWw19), the value with the shifting set value added is the target for the check code.

(6) Operation example of the check code detection

Ex. When values are set for a channel with output range of -10 to 10V in the main D/A converter module as follows:

- "CH□ Scaling enable/disable setting": "0: Enable"
- "CH□ Scaling upper limit value": 24000
- "CH□ Scaling lower limit value": -24000
- "CH□ Shifting set value (RWw6 to RWw9)": -200

8.12 Alert Output Function

This function outputs an alert when a digital value falls within the alert output range set in advance. The following figure schematically shows how the alert output behaves in the main D/A converter module.

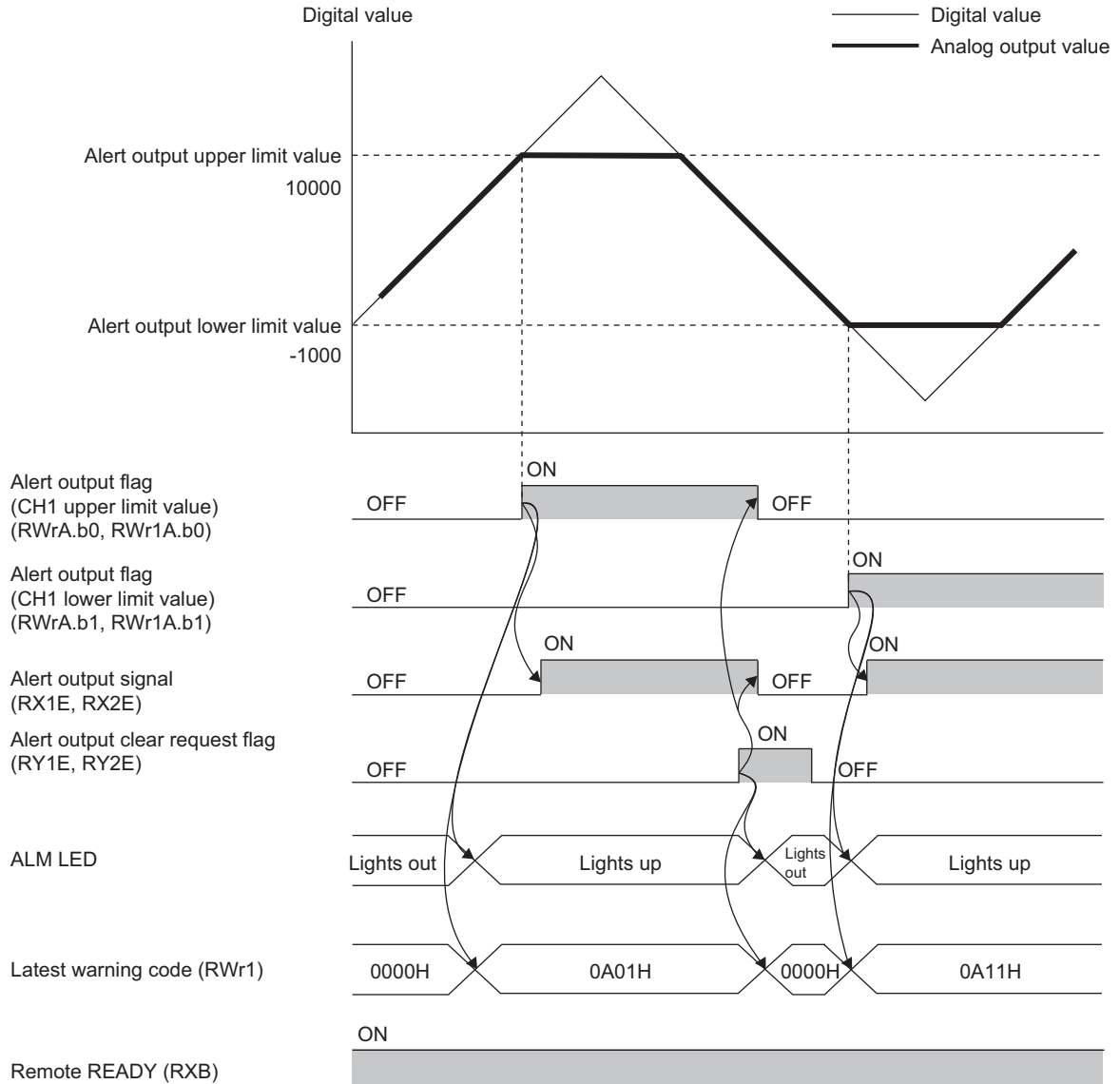

(1) Alert output notification

(a) For the main D/A converter module

When the digital value is greater than the alert output upper limit value, or smaller than the alert output lower limit value, an alert is indicated by Alert output flag (RWrA), Alert output signal (RX1E), and the lighted up ALM LED of the main module.

- Alert output flag (RWrA): The bit corresponding to the contents of the alert turns on (☞ Page 182, Appendix 2 (4)).
- Alert output signal (RX1E): ON
- ALM LED of the main module: On

In addition, alarm code 0A△□H gets stored in Latest warning code (RWr1).

(b) For the extension D/A converter module

When the digital value is greater than the alert output upper limit value, or smaller than the alert output lower limit value, an alert is indicated by Alert output flag (RWr1A), Alert output signal (RX2E), and the lighted up ALM LED of the main module.

- Alert output flag (RWr1A): The bit corresponding to the contents of the alert turns on (☞ Page 182, Appendix 2 (4)).
- Alert output signal (RX2E): ON
- ALM LED of the main module: On

In addition, alarm code 1C△□H gets stored in Latest warning code (RWr1).

For details on the alarm codes, refer to the following:

- Alarm Code List (☞ Page 161, Section 11.3)

(2) Operation of the alert output function

When the digital value exceeds the alert output upper limit value or is below the alert output lower limit value, an alert is output and the analog output value becomes any of the following:

- When the digital value exceeds the alert output upper limit value: An analog value converted from the digital value of the alert output upper limit value is output.
- When the digital value is below the alert output lower limit value: An analog value converted from the digital value of the alert output lower limit value is output.

After an alert occurs, the analog output value returns to the normal value by changing the digital value to a value within the setting range. However, Alert output flag (RWrA, RWr1A) and Alert output signal (RX1E, RX2E) are not cleared. (The ALM LED of the main module remains on.)

(3) Clearing the alert output

The alert output can be cleared by either of the following two methods.

- Turning on and off Alert output clear request flag (RY1E, RY2E)
- Turning on and off Initial data setting request flag (RY9)

When the alert output is cleared, the D/A converter module results in the following state:

- Alert output flag (RWrA, RWr1A) is cleared.
- Alert output signal (RX1E, RX2E) turns off.
- The ALM LED turns off.
- The alarm code 0A△□H or 1C△□H, which is stored in Latest warning code (RWr1), is cleared.

(4) When the scaling function is enabled

When Scaling enable/disable setting (address: 010EH, 020EH) is set to Enable (0), the scale-converted digital value is the target for the alert.

When setting CH1 Alert output upper limit value (address: 0106H, 0206H) to CH4 Alert output lower limit value (address: 010DH, 020DH), set values considering the scaling range.

(5) When the shift function is enabled

When a value is set to CH□ Shifting set value (RWw6 to RWw9, RWw16 to RWw19), the value with the shifting set value added is the target for the alert.

(6) Setting procedure

The setting procedure for the main D/A converter module is as follows:

1. Set "Method selection" to "Parameter write".

 "CC IE Field Configuration" window ⇒ Select the main D/A converter module from "List of stations"
⇒ [CC IE Field Configuration] ⇒ [Online] ⇒ [Parameter Processing of Slave Station]

2. In "Basic module parameter", set "CH□ D/A conversion enable/disable setting" to "0: Enable".

<input checked="" type="checkbox"/>	D/A conversion enable/disable setting			
 CH1 D/A conversion enable/disable setting	1: Disable		
 CH2 D/A conversion enable/disable setting	1: Disable		
 CH3 D/A conversion enable/disable setting	1: Disable		0: Enable
 CH4 D/A conversion enable/disable setting	1: Disable		1: Disable

3. In "Basic module parameter", set "CH□ Alert output setting" to "0: Enable".

<input checked="" type="checkbox"/>	Alert output function			
 CH1 Alert output setting	1: Disable		
 CH1 Alert output upper limit value	0		
 CH1 Alert output lower limit value	0		0: Enable
 CH2 Alert output setting	1: Disable		1: Disable

4. In "Basic module parameter", set the values for "CH□ Alert output upper limit value" and "CH□ Alert output lower limit value".

<input checked="" type="checkbox"/>	Alert output function			
 CH1 Alert output setting	1: Disable		0: Enable
 CH1 Alert output upper limit value	0		16000
 CH1 Alert output lower limit value	0		4000

Item	Setting range
CH□ Alert output upper limit value	-32768 to 32767
CH□ Alert output lower limit value	

Point

For the extension D/A converter module, make the settings for each item of "Ext. module 1_Module parameter".

8.13 Trigger Output Function

Using this function, the D/A converter module performs the D/A conversion at the timing of a trigger output request.

Point

- This function can be used only when the drive mode is set to trigger output mode.
- The D/A converter module converts analog values into digital values in all the channels where the D/A conversion is enabled, every time Trigger output request (RY19, RY29) is turned on.

(1) Combination with the external signal assignment function

Using this function with the external signal assignment function enables the D/A conversion by the trigger output request at when the remote input signal of the extension input module is turned on.

For the external signal assignment function, refer to the following:

- External signal assignment function (Page 130, Section 8.16 (2))

Point

An extension input module is required when the trigger output function is used with the external signal assignment function.

(2) Restrictions

The following table lists the restrictions on the trigger output function.

Function name	Restrictions
Shift function	Cannot be used. The setting of CH□ Shifting set value (RWw6 to RWw9, RWw16 to RWw19) will be ignored.

(3) How the trigger output function operates

After the D/A conversion-enabled channel is set and Initial data setting request flag (RY9) is turned on and off, the D/A converter module waits for trigger input.

Once Trigger output request (RY19, RY29) is turned on, the D/A converter module performs the D/A conversion for all the channels where the D/A conversion is enabled.

Ex. The following figure shows the operation in the main D/A converter module until Trigger output completed flag (RX19) turns on after Trigger output request (RY19) is turned on.

- 1) Once Trigger output request (RY19) is turned on, the D/A conversion starts.
- 2) The D/A conversion in CH1 is performed and the analog output value in CH1 is updated. The D/A conversion is serially performed also for CH2, CH3, and CH4.
- 3) Trigger output completed flag (RX19) turns on when the analog output value is updated in all the channels.
- 4) When Trigger output completed clear request (RY1A) is turned on, Trigger output completed flag (RX19) turns off.

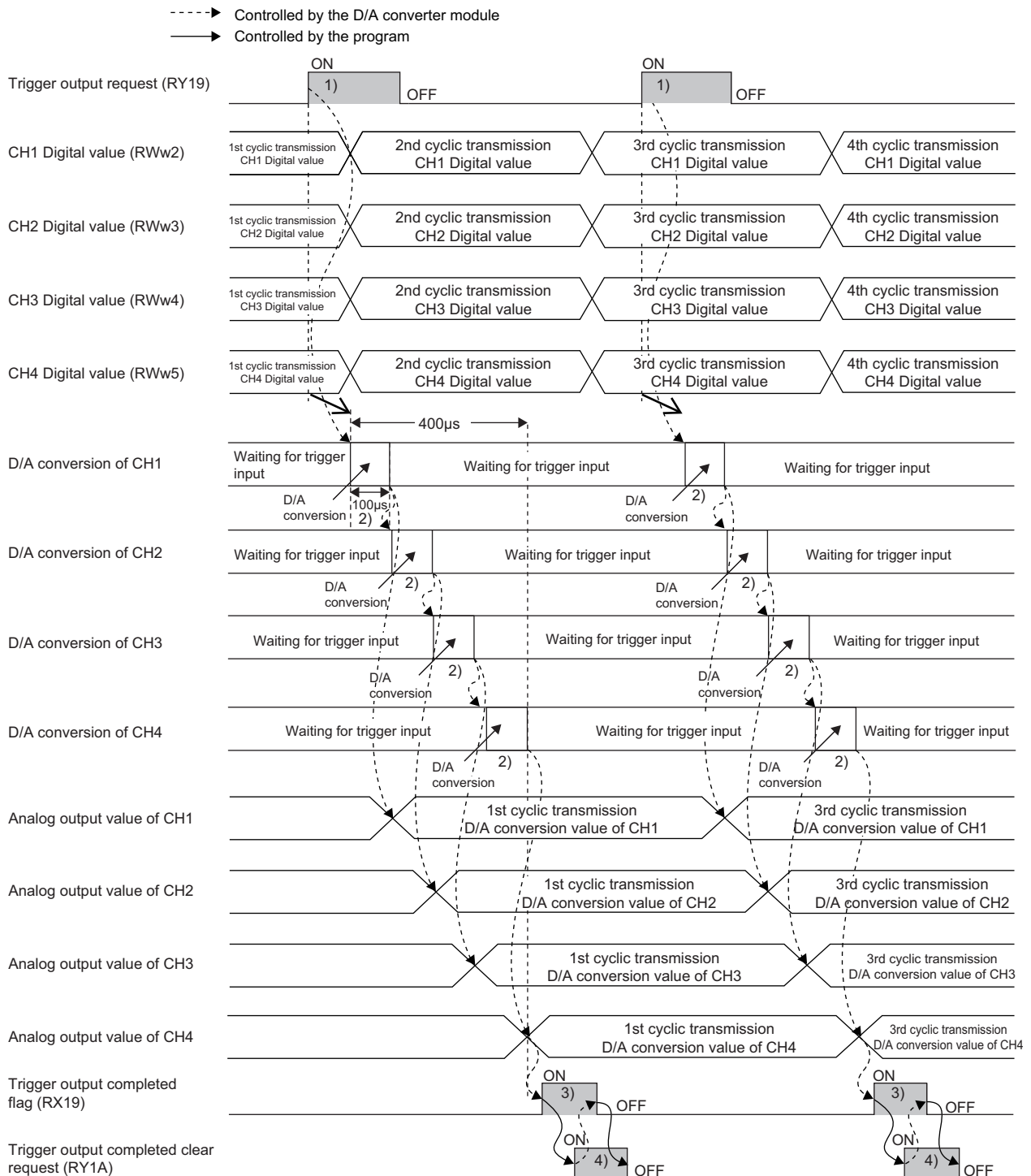

- With the extension D/A converter module connected, processing time (100μs) arises in the period from the completion of conversion processing of each channel to the start of conversion processing of the next channel. Thus, the processing time is 200μs per channel of a main D/A converter module and extension D/A converter module.
- When an extension A/D converter module is connected, the extension A/D converter module operates in trigger conversion mode. In addition, processing time (100μs) arises in the period from the completion of conversion processing of each channel to the start of conversion processing of the next channel. Thus, the processing time is 200μs per channel of a main D/A converter module and extension A/D converter module.

(4) From the start of the trigger output to the completion

Set Mode switch (address: 0000H) to Trigger output mode (1H).

Turning on and off Initial data setting request flag (RY9) results in "0920H" being stored to Latest warning code (RWr1).

Turning off and on the module power supply results in Trigger output completed flag (RX19, RX29) turning off and the module waiting for trigger input.

The following figure shows the operation until the completion of D/A conversion after turning on Trigger output request (RY19, RY29) from off.

Turning on Trigger output request (RY19, RY29) from off enables the D/A converter module to perform D/A conversion processing. Once the D/A conversion is completed, Trigger output completed flag (RX19, RX29) turns on from off.

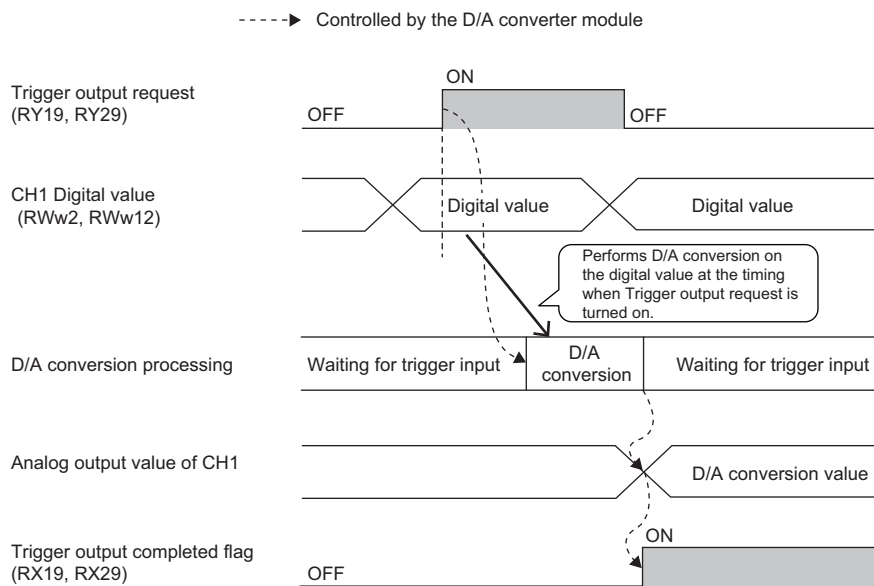

(5) Trigger output completed clear request

The following describes the trigger output completed clear request.

(a) Trigger output completed clear request

The following figure shows the operation where Trigger output completed flag (RX19, RX29) turns off by turning on Trigger output completed clear request (RY1A, RY2A).

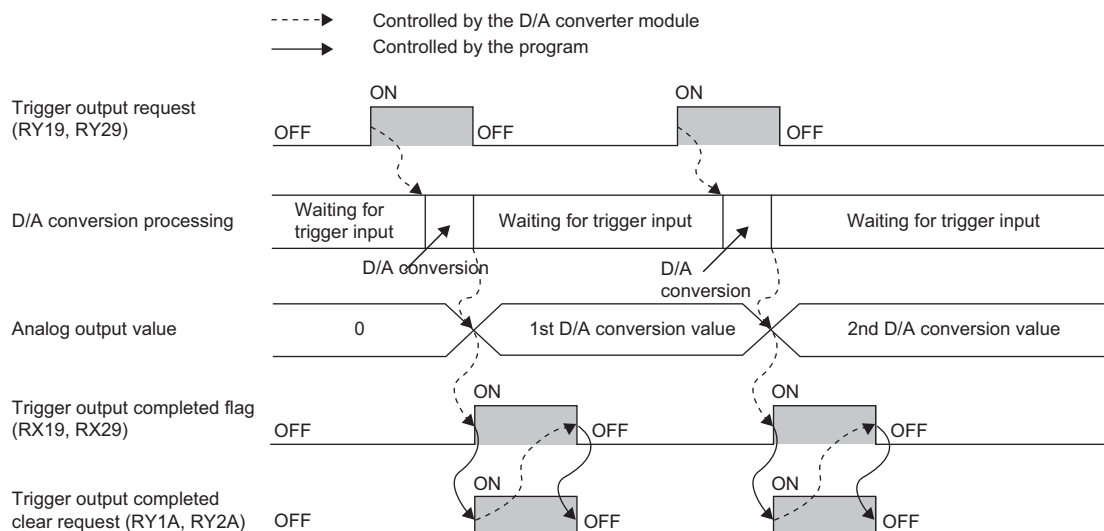

Even when Trigger output completed clear request (RY1A, RY2A) is turned on while Trigger output completed flag (RX19, RX29) is on, the D/A converter module accepts the trigger output request.

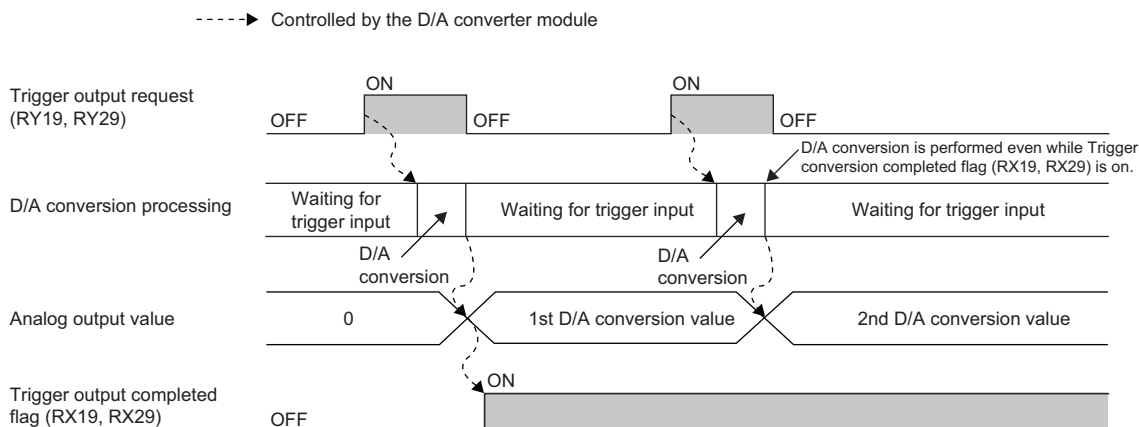

(b) Method for Trigger output completed clear request

The time required until Trigger output completed flag (RX19, RX29) turns off by Trigger output completed clear request (RY1A, RY2A) depends on the sequence scan time and the link scan time.

To use Trigger output completed flag (RX19, RX29) as an interlock, turn on Trigger output request (RY19, RY29) after Trigger output completed flag (RX19, RX29) turns off.

(6) CH□ Output enable/disable flag

The following describes Trigger output request (RY19, RY29) and CH□ Output enable/disable flag (RY10 to RY13, RY20 to RY23).

- When Trigger output request (RY19, RY29) is turned on while CH1 Output enable/disable flag (RY10, RY20) is set to disabled, the D/A conversion is performed, but the analog output value does not change from the offset value.
- Even when CH1 Output enable/disable flag (RY10, RY20) is set to enabled, the analog output value does not change from the offset value until the D/A conversion is performed by another Trigger output request (RY19, RY29).

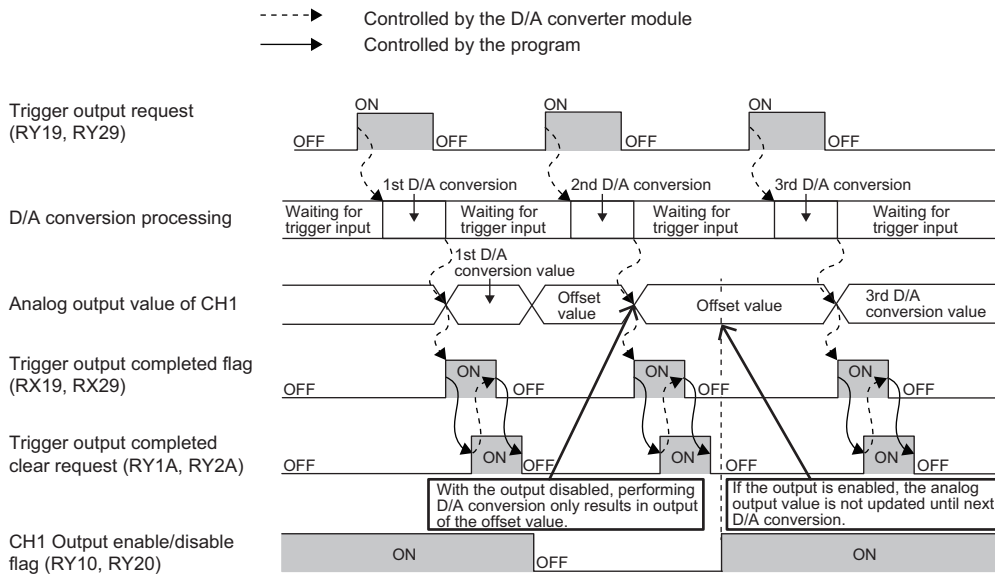

(7) Analog output HOLD/CLEAR function

The following describes Trigger output request (RY19, RY29) and the analog output HOLD/CLEAR function.

- Even if Trigger output request (RY19, RY29) is turned on while the analog output HOLD/CLEAR function is being executed, the D/A conversion is not performed. This is the same for the trigger output request assigned to the extension digital input module as an external signal.
- Even when the operating status of the CPU module is back to RUN, the analog output value is not updated until the D/A conversion is performed by another Trigger output request (RY19, RY29).

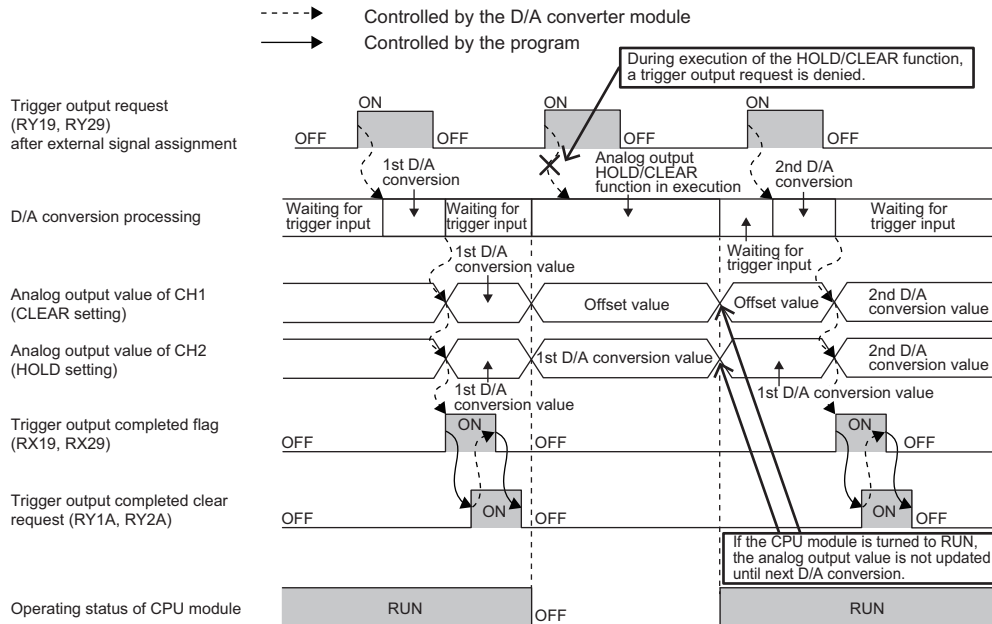

(8) Response time

The following describes the response time until Trigger output completed flag (RX19, RX29) turns on after the trigger output is requested.

(a) When Trigger output request (RY19) of the main D/A converter module is assigned to Remote input (RX) using the external signal assignment function

(Response time of the main D/A converter module)^{*1} + (Response time of the extension input module)^{*2} [ms]

- *1 The response time of the main D/A converter module is calculated as shown below.
(Number of conversion enabled channels in the main D/A converter module) × 0.1 [ms]
- *2 The response time of the extension input module is the minimum time period until the main D/A converter module recognizes an input from the extension input module. The response time of the extension input module is calculated as shown below.
(Input response time setting) + 0.5 [ms]

(b) When Trigger output request (RY19, RY29) is not assigned to Remote input (RX) using the external signal assignment function

$SM^{*1} + LS^{*2} + (\text{Response time of the D/A converter module})^{*3}$ [ms]

- *1 SM: Sequence scan time [ms] (☞ User's manual for the CPU module used in the master station)
- *2 LS: Link scan time [ms] (☞ User's manual for the master/local module used)
- *3 The response time of the D/A converter module is calculated as shown below.

Extension analog module	Response time of the D/A converter module
Not connected	Response time of the main D/A converter module: Number of D/A-conversion enabled channels in the main D/A converter module × 0.1 [ms]
Connected	Response time of the main D/A converter module: Number of D/A-conversion enabled channels in the main D/A converter module × 0.2 [ms] Response time of the extension D/A converter module: Number of D/A-conversion enabled channels in the extension D/A converter module × 0.2 [ms]

(9) Input interval and the ON and OFF time of the trigger output request

When turning on Trigger output request, turn on or off Trigger output request satisfying the reference values of the following items.

- Input interval of the trigger output request
- ON time of the trigger output request
- OFF time of the trigger output request

(a) When Trigger output request (RY19) of the main D/A converter module is assigned to Remote input (RX) using the external signal assignment function

The following table lists the input interval, ON time, and OFF time of Remote input (RX) to which Trigger output request (RY19) of the main D/A converter module is assigned.

Item	Reference value
Input interval of the trigger output request	(Response time of the extension input module) ^{*1} [ms] or longer
ON time of the trigger output request	
OFF time of the trigger output request	

- *1 The response time of the extension input module is the minimum time period until the main D/A converter module recognizes an input from the extension input module. The response time of the extension input module is calculated as shown below.
(Input response time setting) + 0.5 [ms]

(b) When Trigger output request (RY19, RY29) is not assigned to Remote input (RX) using the external signal assignment function

The following lists the input interval, ON time, and OFF time of Trigger output request (RY19, RY29).

Item	Reference value
Input interval of the trigger output request	$SM^{*1} + LS^{*2} + T^{*3}$ [ms]
ON time of the trigger output request	
OFF time of the trigger output request	

*1 SM: Sequence scan time [ms] (User's manual for the CPU module used in the master station)

*2 LS: Link scan time [ms] (User's manual for the master/local module used)

*3 T is the values shown below.

Extension analog module	Value of T
Not connected	0.2
Connected	0.3

-----▶ Controlled by the D/A converter module

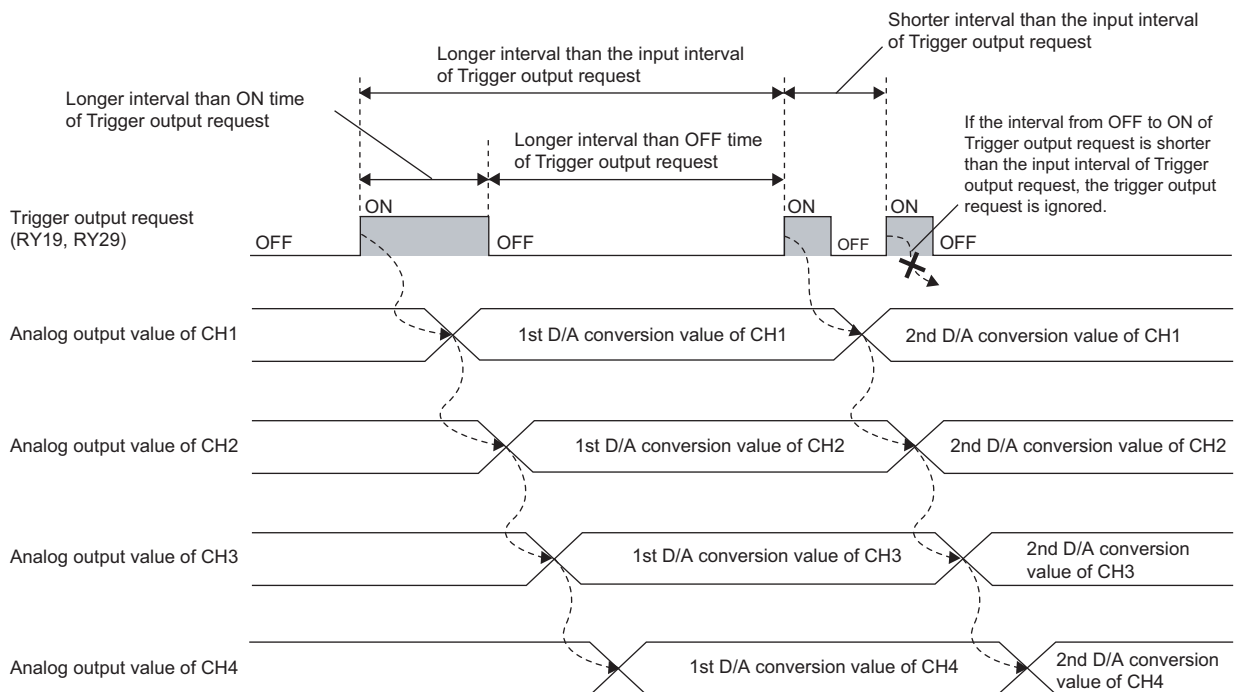

(10) Setting procedure

1. Set "Method selection" to "Parameter write".

 "CC IE Field Configuration" window ⇒ Select the main D/A converter module from "List of stations"
⇒ [CC IE Field Configuration] ⇒ [Online] ⇒ [Parameter Processing of Slave Station]

2. In "Station parameter", set "Mode switch" to "1: Trigger output mode".

<input checked="" type="checkbox"/>	Mode switch	9: Automatic judgment mode		
<input checked="" type="checkbox"/>	External signal assignment setting			
	Trigger output signal assignment	0xFFFF		0: Normal conversion mode 1: Trigger conversion mode
	Alert output signal assignment	0xFFFF		9: Automatic judgment mode
	Event filter assignment	0xFFFF		

3. In "Basic parameter", set "CH□ D/A conversion enable/disable setting" to "0: Enable".

<input checked="" type="checkbox"/>	D/A conversion enable/disable setting			
	CH1 D/A conversion enable/disable setting	1: Disable		
	CH2 D/A conversion enable/disable setting	1: Disable		
	CH3 D/A conversion enable/disable setting	1: Disable		0: Enable
	CH4 D/A conversion enable/disable setting	1: Disable		1: Disable

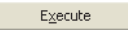
4. Click  button to write the parameters to the D/A converter module.

5. Check that "0920H" is stored in Latest warning code (RW1).

 [Online] ⇒ [Monitor] ⇒ [Device/Buffer Memory Batch]

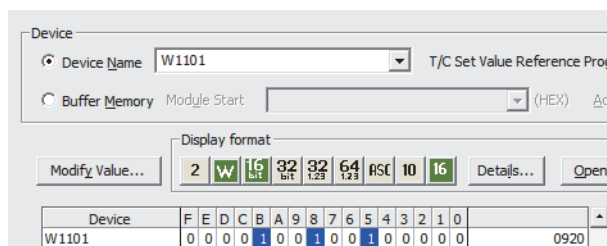

Device	F	E	D	C	B	A	9	8	7	6	5	4	3	2	1	0	
W1101	0	0	0	0	1	0	0	1	0	0	1	0	0	0	0	0	0920

6. Turn off and on the module power supply or perform remote reset to switch the mode of the D/A converter module to trigger output mode.

Point

For the extension D/A converter module, make the settings for each item of "Ext. module 1_Module parameter".

8.14 CC-Link IE Field Network Synchronous Communication Function

This function performs D/A conversion with a synchronization period of the master station that supports the CC-Link IE Field Network synchronous communication function.

This enables the D/A converter module to operate at the same timing of other slave stations on the same network.

(1) Applicable module and software

The table below lists modules and software required to use the CC-Link IE Field Network synchronous communication function.

Module and software	Supported version
Simple motion module	First five digits of the serial number are 15092 or later.
GX Works2	Version 1.525X or later
RJ71GF11-T2 or RJ71EN71	(No restriction)
GX Works3	Version 1.005F or later

(2) Restrictions

This section describes restrictions to use the CC-Link IE Field Network synchronous communication function.

(a) Restrictions to use this function with other functions

Function name	Restrictions
Shift function	Cannot be used. The setting of CH□ Conversion value shift amount (RWw2 to RWw5, RWw12 to RWw15) will be ignored.
Extension I/O function	The extension I/O module can be used, but input and output of the extension I/O module is not synchronized with the operation cycle of the simple motion module.
Cyclic data update watch function	The setting of Cyclic data update watch time setting (address: 0007H) will be ignored.

(b) Restrictions on the network parameter settings (RWw/RWr)

Set the network parameters (RWw/RWr) so that RWwF/RWrF are assigned.

(3) How the CC-Link IE Field Network synchronous communication function operates

Every synchronization cycle of the master station, the D/A conversion is performed for the D/A conversion enabled channels.

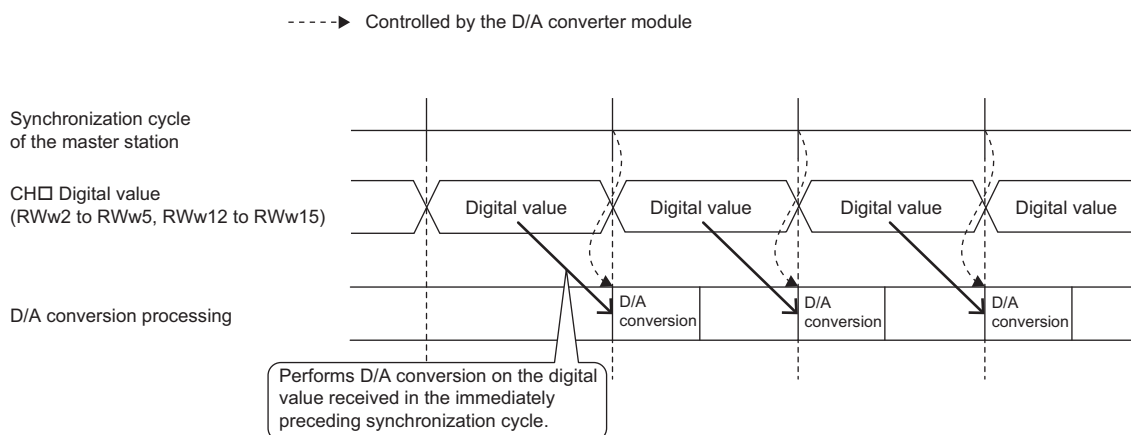

(a) When an extension module is not connected or an extension I/O module is connected

The figure below shows the operation timing under the following settings:

- Synchronization cycle of the master station: 0.88ms
- Number of conversion enabled channels of the main D/A converter module: 4 channels

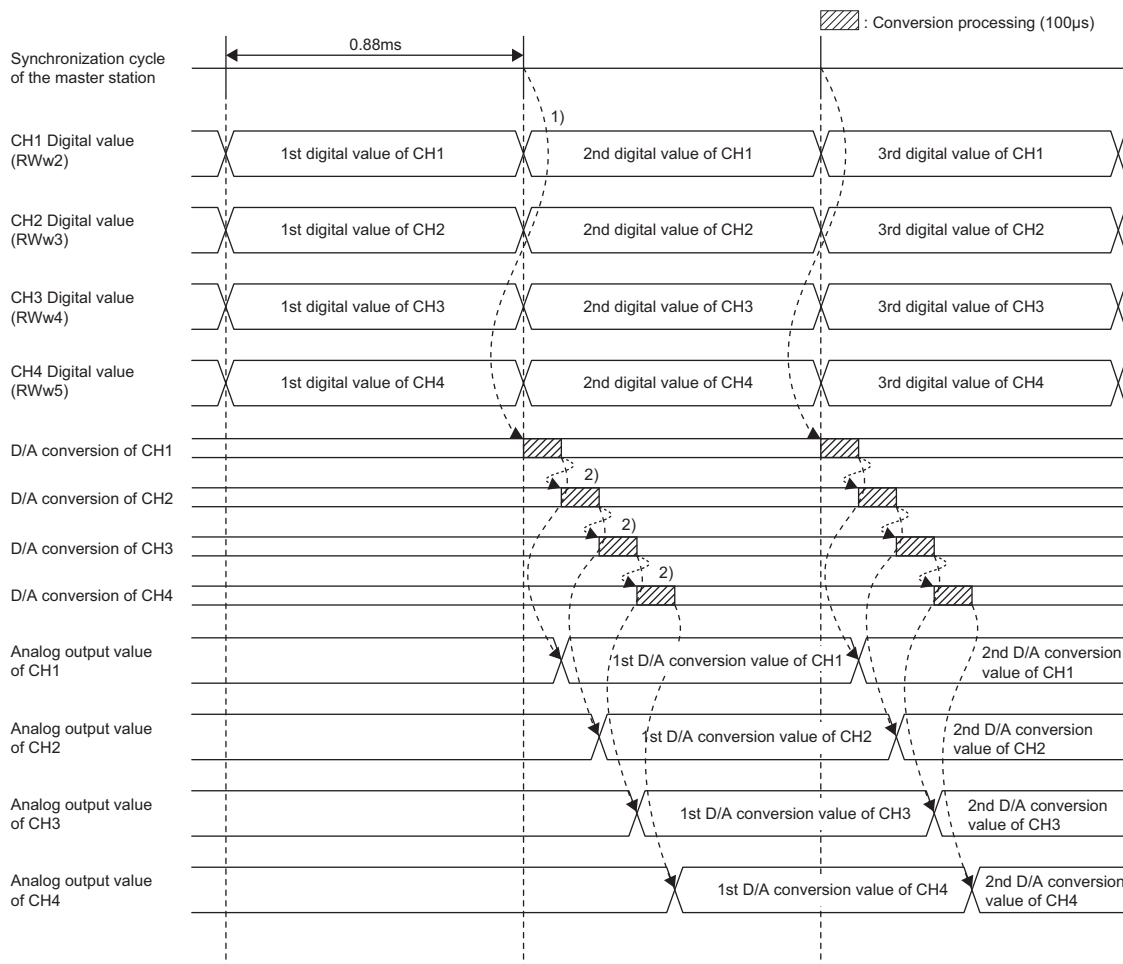

No.	Description
1)	The D/A conversion is started when the synchronization cycle of the master station switches to the next cycle.
2)	The D/A conversion is performed for 100µs per channel, from CH1 to CH4.

(b) When an extension D/A converter module is connected

The D/A conversion processing of the main D/A converter module and the D/A conversion processing of the extension D/A converter module are performed for each synchronization cycle of the master station as follows.

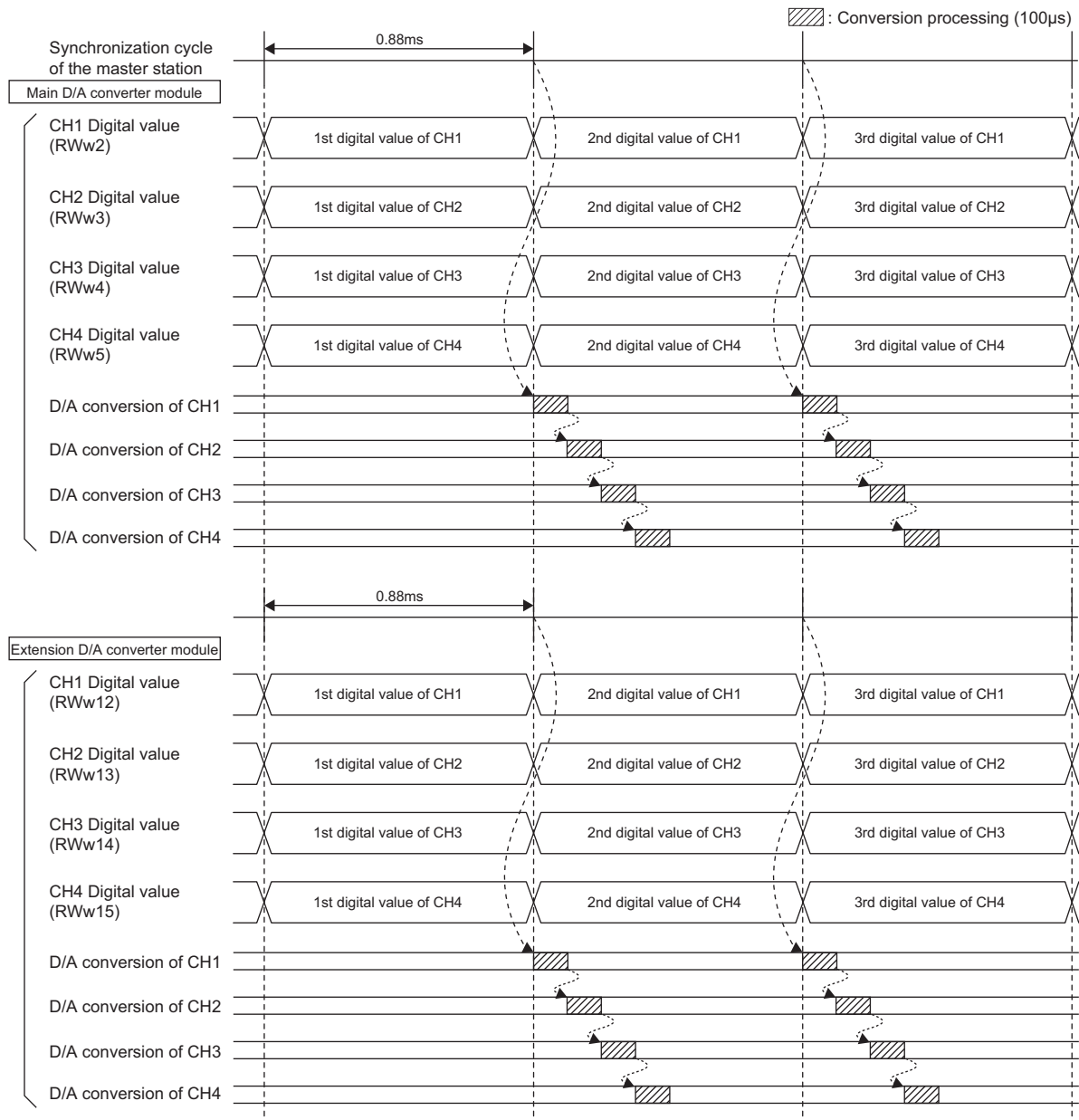

Point

With an extension analog module connected, normal mode or trigger output mode involves processing time (100μs) in the period from the completion of conversion processing of each channel to the start of conversion processing of the next channel; however, synchronous communication mode does not involve this processing time.

(c) When an extension A/D converter module is connected

The D/A conversion processing of the main D/A converter module and the A/D conversion processing of the extension A/D converter module are performed for each synchronization cycle of the master station as follows.

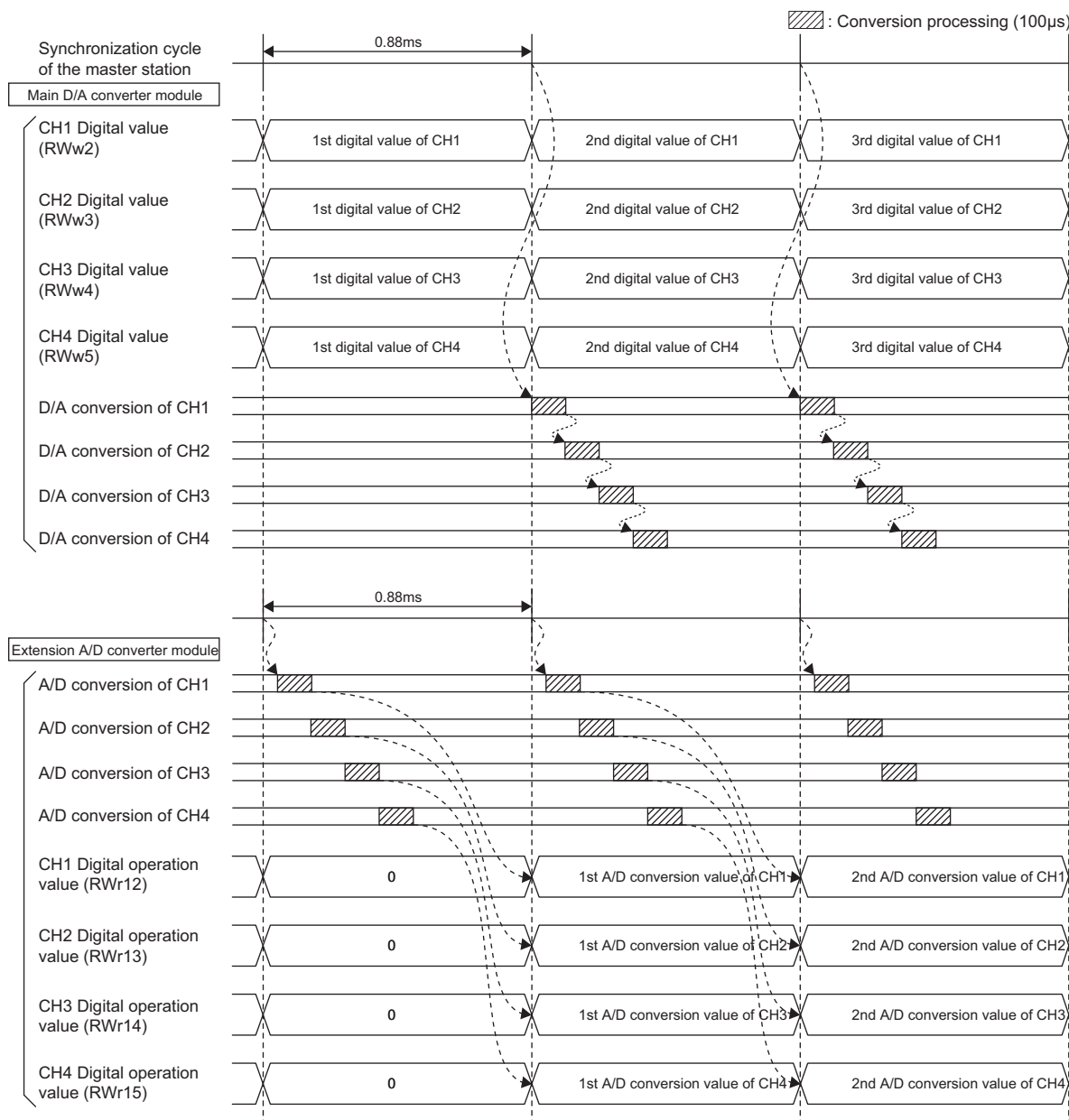

Point

With an extension analog module connected, normal mode or trigger output mode involves processing time (100µs) in the period from the completion of conversion processing of each channel to the start of conversion processing of the next channel; however, synchronous communication mode does not involve this processing time.

(d) SB/SW signals used with the CC-Link IE Field Network synchronous communication function

To check the operating status of the D/A converter module (synchronous or asynchronous), use the following link special register (SW) on the master station.

- Synchronous/asynchronous operation status information (each station) (SW01C8 to SW01CF)

For details, refer to the following:

When the master station is RJ71GF11-T2 or RJ71EN71

- MELSEC iQ-R CC-Link IE Field Network User's Manual (Application)

When the master station is a simple motion module

- MELSEC-Q QD77GF Simple Motion Module User's Manual (Network)

When writing a value to CH□ Digital value (RWw2 to RWw5, RWw12 to RWw15), use the condition of the above mentioned link special register (SW) (the corresponding bit of the register being on) as an interlock.

The following figure shows the program example to write a value to CH1 Digital value and CH2 Digital value of the main D/A converter module with station number 17.

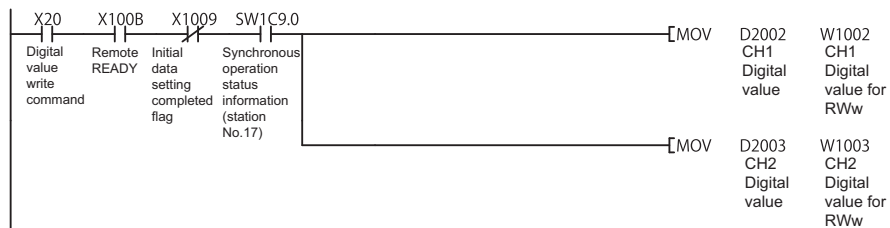

(4) Setting procedure (master station)

1. Set the synchronization cycle of the master station to any of the following.

- 0.88ms
- 1.77ms
- 3.55ms

For details on the setting method, refer to the following:

When the master station is RJ71GF11-T2 or RJ71EN71

MELSEC iQ-R Inter-Module Synchronization Function Reference Manual

When the master station is a simple motion module

MELSEC-Q QD77GF Simple Motion Module User's Manual (Positioning Control)

(5) Setting procedure (D/A converter module)

1. On the "CC IE Field Configuration" window, select the main D/A converter module from "List of stations", and set the values as follows:
 - When the master station is a simple motion module, set "Station No." to 17 or more.
 - In "RX/Ry Setting", make an assignment of 32 points.
 - In "RWw/RWr Setting", make an assignment of 16 points.
2. Open the "Parameter Processing of Slave Station" window, and set "Method selection" to "Parameter write".

 "CC IE Field Configuration" window ⇒ Select the main D/A converter module from "List of stations"
⇒ [CC IE Field Configuration] ⇒ [Online] ⇒ [Parameter Processing of Slave Station]

3. In "Station parameter", set "Mode switch" to "9: Automatical judgment mode".

<input checked="" type="checkbox"/>	Mode switch	9: Automatical judgment mode		
<input checked="" type="checkbox"/>	External signal assignment setting			
	Trigger output signal assignment	0xFFFF		0: Normal conversion mode 1: Trigger conversion mode
	Alert output signal assignment	0xFFFF		9: Automatical judgement mode
	Event assignment	0xFFFF		

4. In "Basic module parameter", set "CH□ D/A conversion enable/disable setting" to "0: Enable".

<input checked="" type="checkbox"/>	D/A conversion enable/disable setting			
	CH1 D/A conversion enable/disable setting	1: Disable		
	CH2 D/A conversion enable/disable setting	1: Disable		
	CH3 D/A conversion enable/disable setting	1: Disable		0: Enable
	CH4 D/A conversion enable/disable setting	1: Disable		1: Disable

5. Click  button to write the parameters to the D/A converter module.
6. Check that "0920H" is stored in Latest warning code (RW1).

 [Online] ⇒ [Monitor] ⇒ [Device/Buffer Memory Batch]

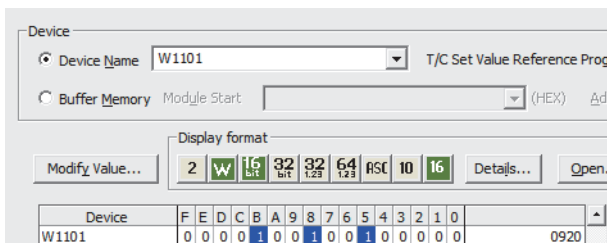

Device	F	E	D	C	B	A	9	8	7	6	5	4	3	2	1	0	
W1101	0	0	0	0	1	0	0	1	0	0	1	0	0	0	0	0	0920

7. Turn off and on the module power supply or perform remote reset to operate the D/A converter module in synchronous communication mode.

Point

For the extension D/A converter module, make the settings for each item of "Ext. module 1_Module parameter".

8.15 Error Notification Function

When an error, warning, or alarm occurs, the D/A converter module notifies the master station of it using remote input signals and remote registers.

Remark

The notification of the error, warning, or alarm can be checked on the LED on the front of the main module. For details, refer to the following:

- PART NAMES (Page 19, CHAPTER 2)

(1) Notification of an error

The D/A converter module notifies the master station of an error in the following method.

Item	Description	Reference
Error flag (RXA)	Turns on when a moderate error or major error occurs.	Page 172, Appendix 1.1 (3)
Latest error code (RWr0)	An error code is stored when a moderate error or major error occurs.	Page 180, Appendix 2 (1)

(a) Method for clearing an error

The method for clearing an error depends on the error type.

Error type	Clearing an error
Major error	The error cannot be cleared.
Moderate error	Turn on Error clear request flag (RYA) or Initial data setting request flag (RY9) after removing the error cause.

(2) Notification of a warning or alarm

The D/A converter module notifies that a warning or alarm occurs to the master station in the following method.

Item	Description	Reference
Warning flag (RX7)	Turns on when a minor error occurs.	Page 170, Appendix 1.1 (1)
Latest warning code (RWr1)	The error code or alarm code is stored when a minor error occurs.	Page 180, Appendix 2 (2)

Point

When an alarm occurs in the extension analog module, the alarm is notified by the ALM LED and (RWr1) of the main analog module.

(a) How to clear a warning or an alarm

The method for clearing an error depends on the error type.

Error type		Clearing an error	
Minor error	Warning	A warning is cleared five seconds after the error cause is removed.*1	
	Alarm*2	Check code	Turn on Error clear request flag (RYA) or Initial data setting request flag (RY9) after writing a digital value within the setting range.
		Alert occurrence	Turn on Alert output clear request flag (RY1E, RY2E) or Initial data setting request flag (RY9) after writing a digital value within the alarm output range.

*1 A warning is in the following state five seconds after the error cause is removed.

- Warning flag (RX7) turns off.
- Latest warning code (RWr1) is cleared.
- The ERR. LED turns off.

*2 The alarm is not automatically cleared. Latest warning code (RWr1) is cleared when the other minor errors are cleared in the alarm status.

The warning codes can be checked in the error history on engineering tools. For the error history, refer to the following:

- Checking by executing a command of the slave station (☞ Page 150, Section 11.1 (1))
- Error history data□ (☞ Page 198, Appendix 3 (17))

Ex. Operation to clear Station number switch changing error (error code: 0940H)

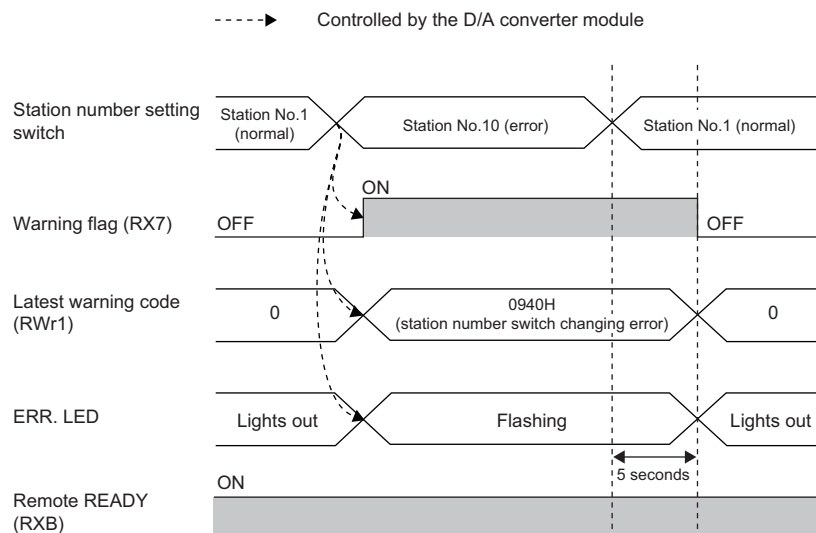

For how to clear an alarm, refer to the following:

- Digital Value Range Check Function (☞ Page 105, Section 8.11)
- Alert Output Function (☞ Page 107, Section 8.12)

(3) Method for clearing an error by executing the command of the slave station

The following shows how to clear an error by executing the command of the slave station. A moderate error and an out-of-range digital value can be cleared.

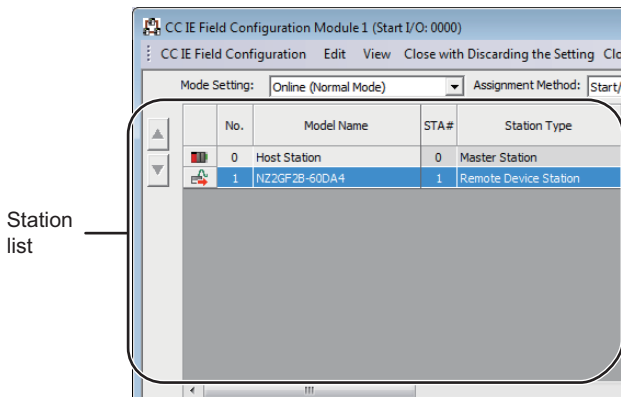



1. On the "CC IE Field Configuration" window, select the main D/A converter module from "List of stations".

2. Open the "Command Execution of Slave Station" window.

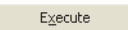
 [CC IE Field Configuration] ⇒ [Online] ⇒ [Command Execution of Slave Station]

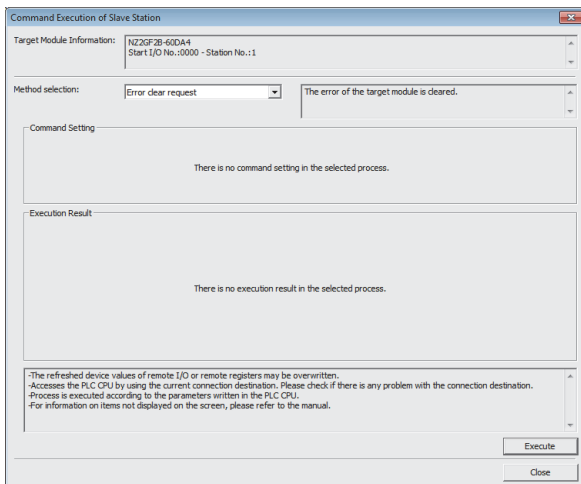
3. Set "Method selection" to "Error clear request" and click  button.



4. In the window that appears (shown left), click  button.

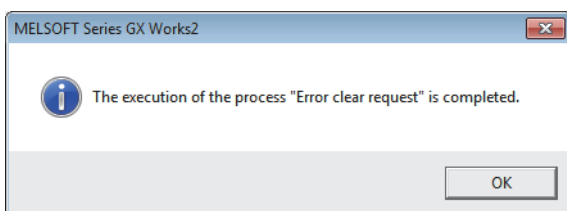

5. The error for the D/A converter module is cleared.

8.16 Functions with an Extension Module Connected

The main D/A converter module permits one extension module to be connected.

Point

- Before replacing the extension module, turn off the module power supply. Disconnecting the extension module during the power-on of the module power supply results in the error code (1F00H) being stored into Latest error code (RWr0), Error flag (RXA) turning on, and the ERR. LED lighting up, which stops the operation.
- After replacing the extension module, write the parameters again.

8.16.1 Available functions with an extension I/O converter module connected

Here is the list of the available functions with an extension I/O module connected:

Function	Reference
External power supply monitoring function	Page 129, Section 8.16.1 (1)
External signal assignment function	Page 130, Section 8.16.1 (2)
Digital output HOLD/CLEAR setting function (referred to as the output HOLD/CLEAR setting function in the manual of I/O modules)	CC-Link IE Field Network Remote I/O Module User's Manual
Input response time setting function	
Number of ON times integration function	

(1) External power supply monitoring function

This function monitors the on/off state of the external power supply with the I/O PW LED of an extension output module indicating the state.

By using External power supply monitor request flag (RY1F), a moderate error is generated when the external power supply is off. Thus, the ON/OFF status of the external power supply is notified and the extension output module can be stopped.

(a) External power supply monitoring function

While External power supply monitor request flag (RY1F) is on, power off of the external power supply causes a moderate error. When using this function, check that the external power supply stabilizes before turning on External power supply monitor request flag (RY1F). When turning off the external power supply, turn off External power supply monitor request flag (RY1F) in advance.

(b) Setting and checking the external power supply monitoring function

Item	Description	Reference
External power supply monitor request flag (RY1F)	Allows the external power supply monitoring function to be enabled or disabled.	Page 179, Appendix 1.2 (7)
External power supply monitor status flag (RX1F)	Indicates whether the external power supply monitoring function is enabled or disabled.	Page 175, Appendix 1.1 (7)

(2) External signal assignment function

This function allows remote input or output signals of the main D/A converter module to be assigned to remote I/O signals of the extension I/O module connected. Signals can be input from the extension I/O module and error signals can be output to the external at the fixed timing without influence from the sequence scan or link scan.

Target remote I/O signals of external signal assignment	Area to be set
Trigger output request (RY19)	"Trigger output signal assignment"
Alert output signal (RX1E)	"Alert output signal assignment"
Error flag (RXA)	"Error flag assignment"
Warning flag (RX7)	"Warning flag assignment"

(a) How the external signal assignment function operates

Ex. Assigning Alert output signal (RX1E) of a main D/A converter module to RY2A of an extension output module

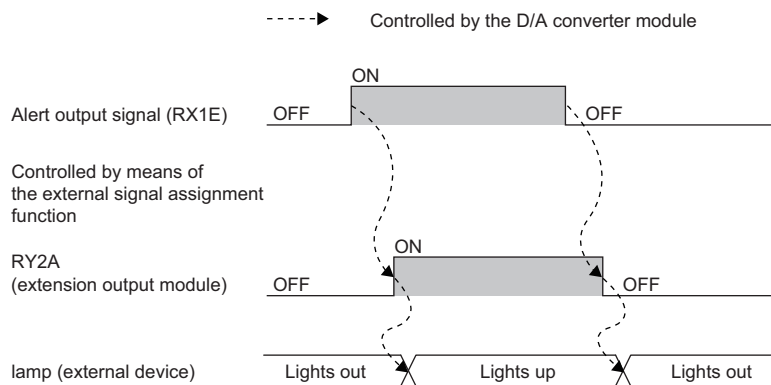
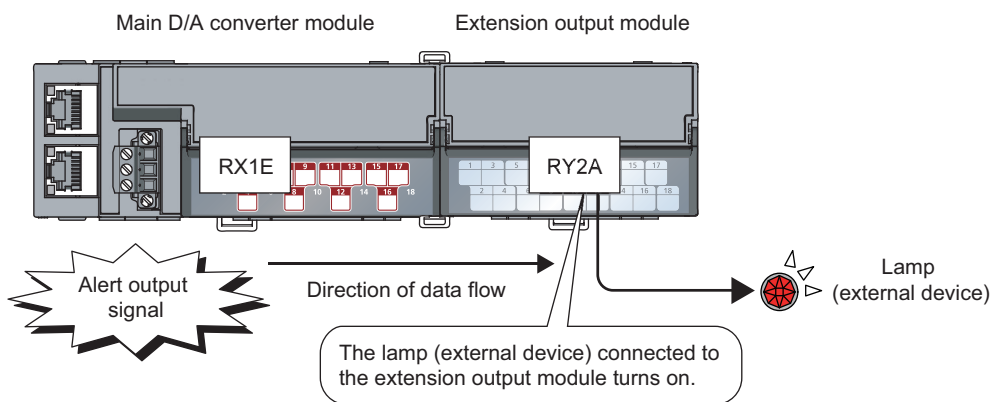

Point

Assigning a remote input signal of the main D/A converter module to a remote output signal of the extension output module does not allow the assigned remote output signal to be turned on/off or monitored by program. Turn on/off or monitor the pre-assigned remote input signal of the main module. (In the above example, turn on/off or monitor RY2A.)

(b) Setting procedure**1. Set "Method selection" to "Parameter write".**

 "CC IE Field Configuration" window ⇒ Select the main D/A converter module from "List of stations"
⇒ [CC IE Field Configuration] ⇒ [Online] ⇒ [Parameter Processing of Slave Station]

2. In "Basic module parameter", set "CH□ D/A conversion enable/disable setting" to "0: Enable".

<input checked="" type="checkbox"/>	D/A conversion enable/disable setting			
<input type="checkbox"/>	CH1 D/A conversion enable/disable setting	1: Disable		
<input type="checkbox"/>	CH2 D/A conversion enable/disable setting	1: Disable		
<input type="checkbox"/>	CH3 D/A conversion enable/disable setting	1: Disable		0: Enable
<input type="checkbox"/>	CH4 D/A conversion enable/disable setting	1: Disable		1: Disable

3. In "Basic module parameter", set "CH□ Alert output setting" to "0: Enable".

<input checked="" type="checkbox"/>	Alert output function			
<input type="checkbox"/>	CH1 Alert output setting	1: Disable		
<input type="checkbox"/>	CH1 Alert output upper limit value	0		
<input type="checkbox"/>	CH1 Alert output lower limit value	0		0: Enable
<input type="checkbox"/>	CH2 Alert output setting	1: Disable		1: Disable

4. In "Basic module parameter", set the values for "CH□ Alert output upper limit value" and "CH□ Alert output lower limit value".

<input checked="" type="checkbox"/>	Alert output function			
<input type="checkbox"/>	CH1 Alert output setting	1: Disable		0: Enable
<input type="checkbox"/>	CH1 Alert output upper limit value	0		16000
<input type="checkbox"/>	CH1 Alert output lower limit value	0		4000

5. In "Basic module parameter", set "Alert output signal assignment" to 0x002A. (The string 2A is derived from RY2A.)

<input checked="" type="checkbox"/>	External signal assignment setting			
<input type="checkbox"/>	Trigger output signal assignment	0xFFFF		
<input type="checkbox"/>	Alert output signal assignment	0xFFFF		0x002A

Point

- Signals other than remote I/O signals assigned to the external module cannot be set with the external signal assignment function.
Such a setting results in the error code (017△H) being stored in Latest error code (RWr0), Error flag (RXA) turning on, and the ERR. LED lighting up.
- Multiple remote I/O signals of the main module cannot be assigned to a remote output signal of the extension module.
Such a setting results in the error code (0180H) being stored in Latest error code (RWr0), Error flag (RXA) turning on, and the ERR. LED lighting up.
- The external signal assignment function cannot be used together with the digital output HOLD/CLEAR function.
When "Digital output HOLD/CLEAR setting" is set to "1: HOLD", the setting is ignored and the D/A converter module operates with "0: CLEAR" set.

(c) Operation when an error occurs

Depending on whether the remote I/O signals of the extension I/O module are used as general-purpose I/O signals or assigned for the external signal assignment function, the operation of the D/A converter module for an error differs as shown in the following table.

Remote I/O signal		Remote input (RX)		Remote output (RY)			
Digital output HOLD/CLEAR setting function		—		CLEAR		HOLD	
External signal assignment function		Not assigned	Assigned	Not assigned	Assigned	Not assigned	Assigned* ¹
Status of the D/A converter module	Minor error	Same as the normal operation		Same as the normal operation		Same as the normal operation	
	Moderate error	Clear	Same as the normal operation	Clear	Same as the normal operation	Clear	Same as the normal operation
	Major error	Clear		Clear		Clear	
	In disconnection, or the CPU module being in STOP status	Clear	Same as the normal operation	Clear	Same as the normal operation	Hold* ²	Same as the normal operation

*1 When the external signal assignment function is used, the operation of the D/A converter module is the same as that of when the CLEAR is set for the digital output HOLD/CLEAR setting function, even if HOLD is set.

*2 When "HOLD" is set to Digital output HOLD/CLEAR setting, the Y signal of an extension digital output module is held at the time of disconnection or CPU module STOP.

For different types of errors, the resulting error condition follows the following order of priority:

- Major error > Moderate error > Minor error > In disconnection, or the CPU module being in STOP status

8.16.2 Functions with the extension D/A converter module connected

With the extension D/A converter module connected, D/A conversion processing of up to eight channels is possible.

(1) Available function with the extension D/A converter module connected

Here is the list of the available function with the extension D/A converter module connected:

Function	Description
External power supply monitoring function	Monitors the on/off state of the external power supply of the extension D/A converter module, indicating the monitored state by the RUN LED and External power supply READY flag (RX2F) of the extension D/A converter module. For details, refer to the following: <ul style="list-style-type: none"> External power supply READY flag ( Page 176, Appendix 1.1 (8))

(2) Supplementary information related to the connection of the extension D/A converter module

Here is the list of the supplementary information related to the connection of the extension D/A converter module for each drive mode:

Drive mode	With the extension D/A converter module connected	Reference
Normal mode	Processing time (100 μ s) arises in the period from the completion of conversion processing of each channel to the start of conversion processing of the next channel.	Page 90, Section 8.5 (2)
Trigger output mode	Processing time (100 μ s) arises in the period from the completion of conversion processing of each channel to the start of conversion processing of the next channel.	Page 110, Section 8.13

8.16.3 Functions with the extension A/D converter module connected

When an extension A/D converter module is connected, the A/D conversion processing for four channels and D/A conversion processing for four channels at maximum can be performed.

(1) Available function with the extension A/D converter module connected

Here is the list of the available function with the extension A/D converter module connected:

Function	Description
External power supply monitoring function	Monitors the on/off state of the external power supply of the extension A/D converter module, indicating the monitored state by the RUN LED and External power supply READY flag (RX2F) of the extension A/D converter module. For details, refer to the following:  ICC-Link IE Field Network Analog-Digital Converter Module User's Manual

(2) Supplementary information related to the connection of the extension A/D converter module

Here is the list of the supplementary information related to the connection of the extension A/D converter module for each drive mode:

Drive mode	With the extension D/A converter module connected	Reference
Normal mode	<ul style="list-style-type: none"> Processing time (100μs) arises in the period from the completion of conversion processing of each channel to the start of conversion processing of the next channel. 	Page 91, Section 8.5 (3)
Trigger output mode	<ul style="list-style-type: none"> The extension A/D converter module operates in trigger conversion mode. 	Page 87, Section 8.2 (2)
	<ul style="list-style-type: none"> Processing time (100μs) arises in the period from the completion of conversion processing of each channel to the start of conversion processing of the next channel. 	Page 110, Section 8.13

8.17 CC-Link IE Field Network Diagnostic Function

This function makes it possible to check the presence or absence of a network error, by using the CC-Link IE Field Network diagnostic function from the engineering tool connected to the CPU module.

(1) How to use the function

The following instructions assume the use of GX Works2 as the engineering tool.

1. Establish a connection between GX Works2 and the CPU module.
2. Go to the menu of GX Works2 and start up the CC-Link IE Field Network diagnostics.

 [Diagnostics] ⇒ [CC IE Field Diagnostics]

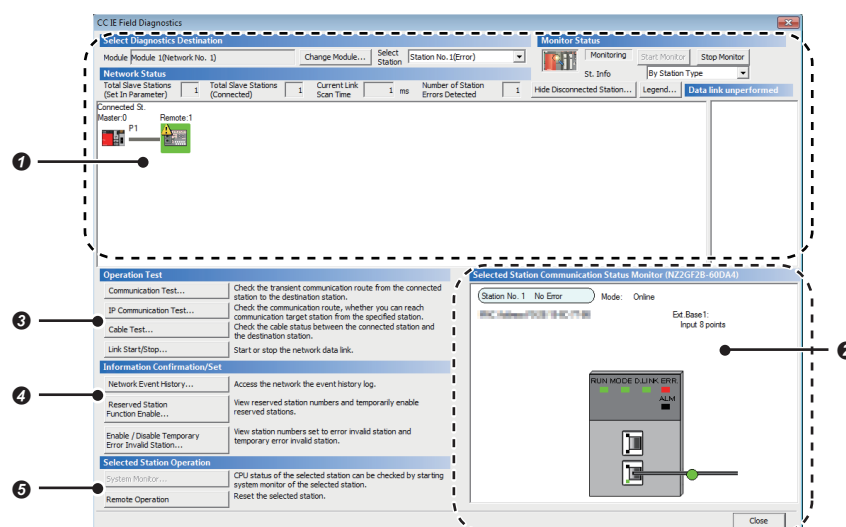

Item to be diagnosed	Description	Reference
① Network configuration and error condition	The condition of the CC-Link IE Field Network can be checked. If an error or a warning occurs in the D/A converter module, an icon appears to show the status of the station.	User's manual for the master/local module used
② Display of selected-station status and error details	The communication status of the station selected in "Networks Status" can be checked.*1	
③ Communication Test	The transient communication route and whether the communication is established from the connected station to the destination station can be checked.	
IP Communication Test	The reaching time and the route of the IP communication from the connected station to the target station can be checked.	
Cable Test	The cable status between the connected station and the destination station can be checked.	
Link Start/Stop	The network data link can be started and stopped.	
④ Network Event History	The history of various events that occurred in the network can be checked.	
Reserved Station Function Enable	A reservation for a station can be temporarily cancelled, and the cancellation can be checked on a list.	
Enable/Disable Ignore Station Errors	A station not set as an error invalid station can be temporarily set as an error invalid station, and the error invalid station setting can be disabled. Also, the station numbers for the modules set as (temporarily) error ignore stations can be checked on a list.	
⑤ System Monitor	The system monitor on the selected station is activated and the status of the module can be checked. This function is unavailable for the D/A converter module.	
Remote operation	The selected station can be reset through the remote operation.	Page 136, Section 8.17 (1) (a)

- *1 "Selected Station Communication Status Monitor", which appears at the bottom right in the window, indicates the communication status of the main D/A converter module. The model name of the main D/A converter module is displayed as "NZ2GF2B-60DA4" there.
- For how to check the error and alarm of the main D/A converter module and extension D/A converter module, refer to the following:
- How to Check Error Codes and Alarm Codes (Page 150, Section 11.1)

Point

Some master/local module or simple motion module may not support all the diagnostics. For details, refer to the user's manual for the master/local module or the simple motion module used.

- User's manual for the master/local module used
- MELSEC-Q QD77GF Simple Motion Module User's Manual (Network)

(a) Remote operation

1. Select the slave station to be reset and click  button.

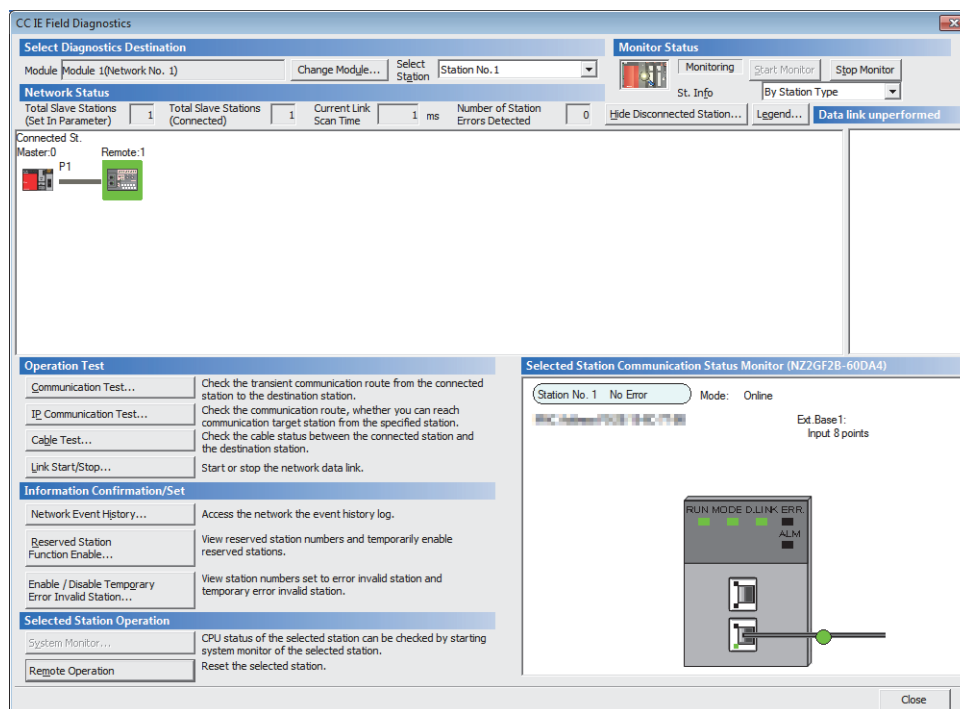

2. In the dialog box that appears (shown below), click  button to start remote reset.

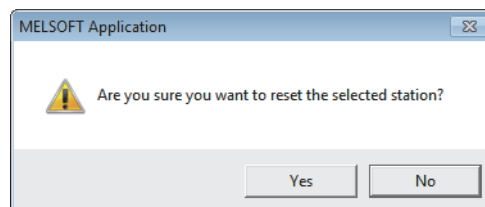

3. In the dialog box that appears (shown below), click  button.

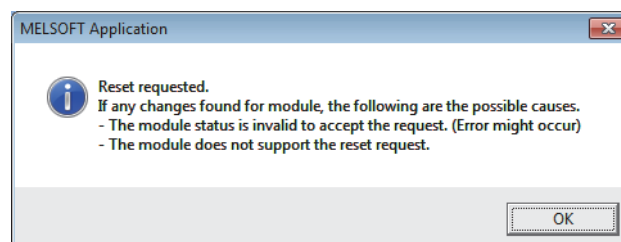

CHAPTER 9 PROGRAMMING

This chapter describes the programming of the D/A converter module.

9.1 Precautions for Programming

This section describes precautions when creating the program of CC-Link IE Field Network.

(1) Program for cyclic transmission

For a program for cyclic transmission, provide interlock between the following link special relay (SB) and the link special register (SW).

- Data link status of the own station (or master station) (SB0049)
- Data link status of each station (SW00B0 to SW00B7)

For the link special relay (SB) and link special register (SW), refer to the following:

 User's manual for the master/local module used

Ex. Interlock example

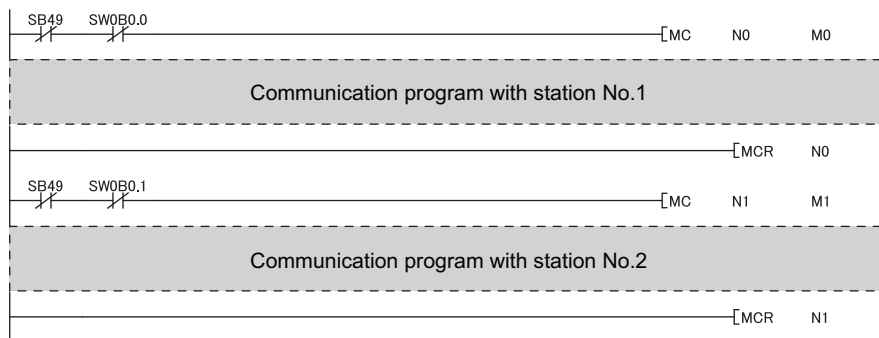

(2) Program for transient transmission

For a program for transient transmission, provide interlock between the following link special relay (SB) and the link special register (SW).

- Baton pass status of the own station (or master station) (SB0047)
- Baton pass status of each station (SW00A0 to SW00A7)

For the link special relay (SB) and link special register (SW), refer to the following:

 User's manual for the master/local module used

Ex. Interlock example



9.2 Programming Procedure

Create a program to execute D/A conversion as illustrated by the following procedure.

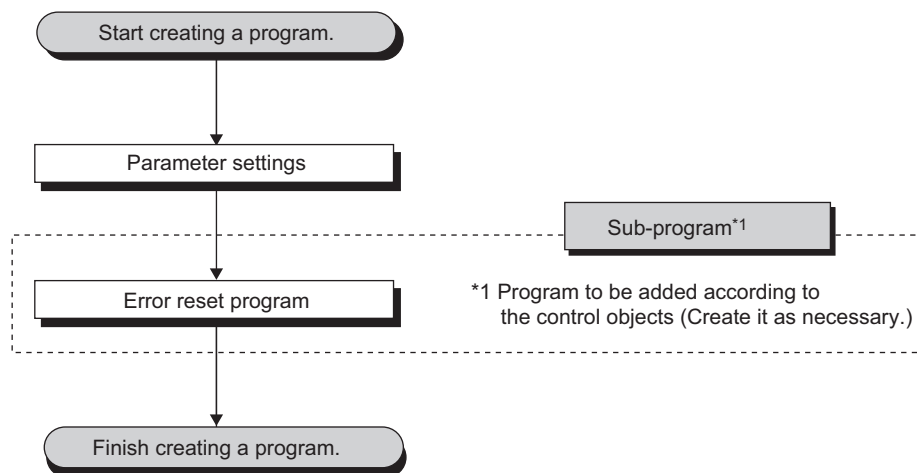

9.3 Program Example

(1) System configuration

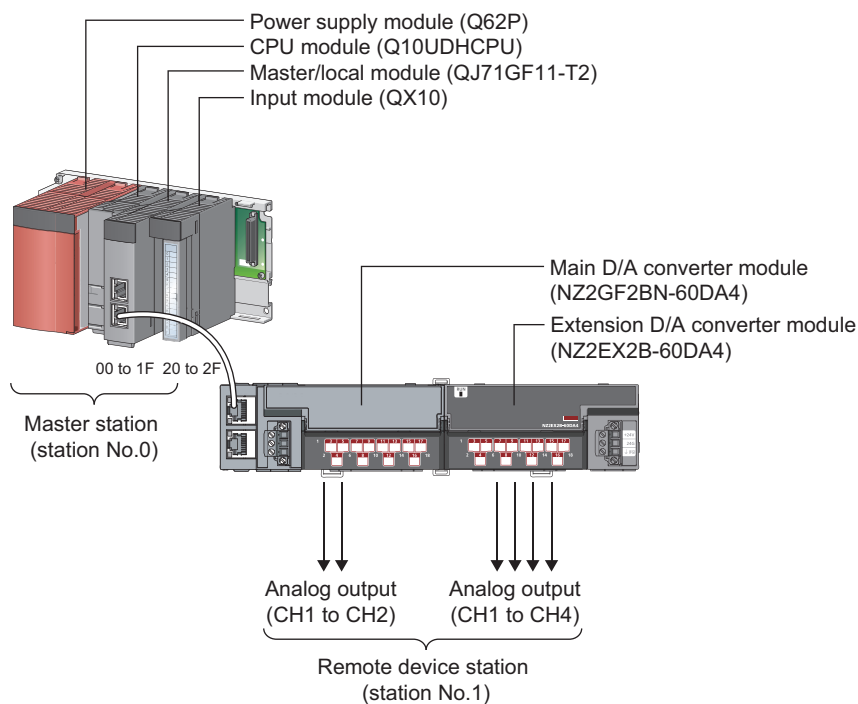

For the settings using the engineering tool, the procedure is described based on the use of GX Works2.

(a) Assignment of link devices

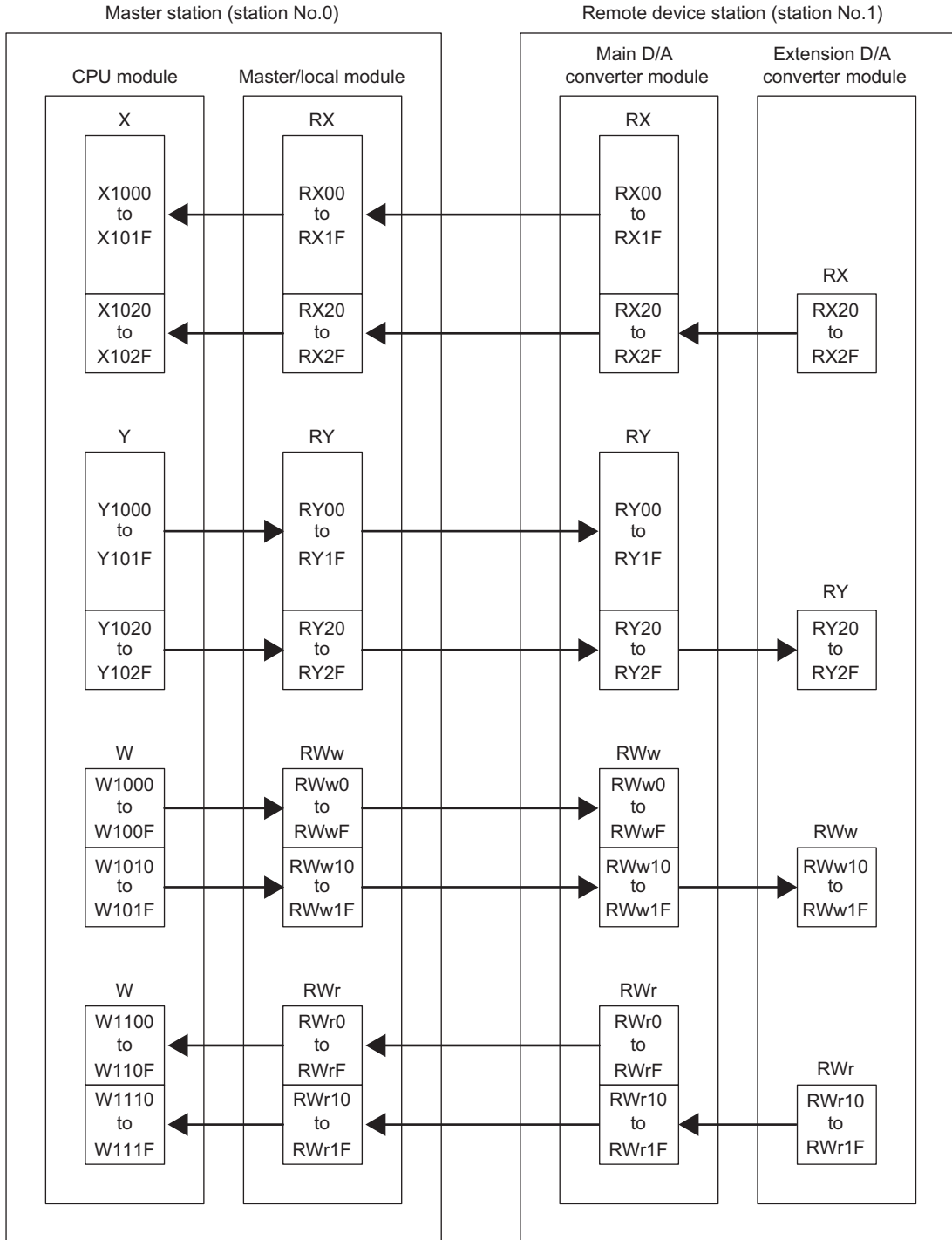

9.3 Program Example

(2) Programming conditions

Here is the programming conditions:

- D/A conversion in CH1 and CH2 of the main D/A converter module is enabled and the written digital values are output in analog. Scaling conversion is performed in CH1 and alert output is performed in CH2.
- D/A conversion in CH1 to CH4 of the extension D/A converter module is enabled and the written digital values are output in analog. Scaling conversion is performed in CH1 and CH3 and alert output is performed in CH2 and CH4.

(3) Initial settings

(a) Station parameter

Setting item	Setting value
Cyclic data update watch time setting	5

For the parameters other than the above, use the initial value.

(b) Basic module parameter

Setting item	Setting value	
D/A conversion enable/disable setting	CH1 D/A conversion enable/disable setting	0: Enable
	CH2 D/A conversion enable/disable setting	0: Enable
Analog HOLD/CLEAR setting	CH1 Analog output HOLD/CLEAR setting	1: HOLD
Alert output function	CH2 Alert output setting	0: Enable
	CH2 Alert output upper limit value	10000
	CH2 Alert output lower limit value	3000
Scaling function	CH1 Scaling enable/disable setting	0: Enable
	CH1 Scaling upper limit value	32000
	CH1 Scaling lower limit value	0

For the parameters other than the above, use the initial value.

(c) Ext. module 1_Module parameter

Setting item	Setting value	
Ext. module 1_D/A conversion enable/disable setting	Ext. module 1_CH1 D/A conversion enable/disable setting	0: Enable
	Ext. module 1_CH2 D/A conversion enable/disable setting	0: Enable
	Ext. module 1_CH3 D/A conversion enable/disable setting	0: Enable
	Ext. module 1_CH4 D/A conversion enable/disable setting	0: Enable
Ext. module 1_Analog output HOLD/CLEAR setting	Ext. module 1_CH1 Analog output HOLD/CLEAR setting	1: HOLD
	Ext. module 1_CH3 Analog output HOLD/CLEAR setting	1: HOLD
Ext. module 1_Alert output function	Ext. module 1_CH2 Alert output setting	0: Enable
	Ext. module 1_CH2 Alert output upper limit value	10000
	Ext. module 1_CH2 Alert output lower limit value	3000
	Ext. module 1_CH4 Alert output setting	0: Enable
	Ext. module 1_CH4 Alert output lower limit value	3000
Ext. module 1_Scaling function	Ext. module 1_CH1 Scaling enable/disable setting	0: Enable
	Ext. module 1_CH1 Scaling upper limit value	32000
	Ext. module 1_CH1 Scaling lower limit value	0
	Ext. module 1_CH3 Scaling enable/disable setting	0: Enable
	Ext. module 1_CH3 Scaling upper limit value	32000
	Ext. module 1_CH3 Scaling lower limit value	0

For the parameters other than the above, use the initial value.

(4) Devices used by user

Device	Description	
X20	Main D/A converter module Digital value write command	QX10 (X20 to X2F)
X22	Main D/A converter module Batch analog output enable command	
X24	Main D/A converter module Alert output clear command	
X26	Error clear command	
X2A	Extension D/A converter module Digital value write command	
X2C	Main D/A converter module Batch analog output enable command	
X2E	Main D/A converter module Alert output clear command	
X1007	Warning flag	NZ2GF2BN-60DA4 (X1000 to X101F)
X1009	Initial data setting completed flag	
X100A	Error flag	
X100B	Remote READY	
X101E	Main D/A converter module Alert output signal	
X102E	Extension D/A converter module Alert output signal	NZ2EX2B-60DA4 (X1020 to X102F)
X102F	External power supply READY flag	
Y100A	Error clear request flag	NZ2GF2BN-60DA4 (Y1000 to Y101F)
Y1010	Main D/A converter module CH1 Output enable/disable flag	
Y1011	Main D/A converter module CH2 Output enable/disable flag	
Y101E	Main D/A converter module Alert output clear request flag	
Y1020	Extension D/A converter module CH1 Output enable/disable flag	
Y1021	Extension D/A converter module CH2 Output enable/disable flag	NZ2EX2B-60DA4 (Y1020 to Y102F)
Y1022	Extension D/A converter module CH3 Output enable/disable flag	
Y1023	Extension D/A converter module CH4 Output enable/disable flag	
Y102E	Extension D/A converter module Alert output clear request flag	
W1002	Main D/A converter module CH1 Digital value	
W1003	Main D/A converter module CH2 Digital value	
W1012	Extension D/A converter module CH1 Digital value	
W1013	Extension D/A converter module CH2 Digital value	
W1014	Extension D/A converter module CH3 Digital value	
W1015	Extension D/A converter module CH4 Digital value	Remote register RWr
W1100	Latest error code	
W1101	Latest warning code	
W1102	Main D/A converter module CH1 Set value check code	
W1103	Main D/A converter module CH2 Set value check code	
W110A	Main D/A converter module Alert output flag	
W1112	Extension D/A converter module CH1 Set value check code	
W1113	Extension D/A converter module CH2 Set value check code	
W1114	Extension D/A converter module CH3 Set value check code	
W1115	Extension D/A converter module CH4 Set value check code	
W111A	Extension D/A converter module Alert output flag	

Device	Description
D2002	Main D/A converter module CH1 Digital value
D2003	Main D/A converter module CH2 Digital value
D2032	Extension D/A converter module CH1 Digital value
D2033	Extension D/A converter module CH2 Digital value
D2034	Extension D/A converter module CH3 Digital value
D2035	Extension D/A converter module CH4 Digital value
D2100	Latest error code
D2110	Main D/A converter module Alert output flag
D2120	Latest warning code
D2130	Main D/A converter module CH1 Set value check code
D2131	Main D/A converter module CH2 Set value check code
D2140	Extension D/A converter module Alert output flag
D2150	Extension D/A converter module CH1 Set value check code
D2151	Extension D/A converter module CH2 Set value check code
D2152	Extension D/A converter module CH3 Set value check code
D2153	Extension D/A converter module CH4 Set value check code
F0	Main D/A converter module CH2 Upper limit alert occurrence
F1	Main D/A converter module CH2 Lower limit alert occurrence
F10	Extension D/A converter module CH2 Upper limit alert occurrence
F11	Extension D/A converter module CH2 Lower limit alert occurrence
F12	Extension D/A converter module CH4 Upper limit alert occurrence
F13	Extension D/A converter module CH4 Lower limit alert occurrence
SM400	Always ON
SB49	Data link status of own station (master station)
SW0B0.0	Data link status of each station (station number 1)
M0	Communication ready flag (station number 1)
N0	Nesting (station number 1)

Device for storage

(5) Setting procedure

Connect GX Works2 to the master station to set up the settings.

1. Create a project on GX Works2.

For "PLC Series", select "QCPU (Q mode)" and for "PLC Type", select "Q10UDH".

 [Project] ⇒ [New...]

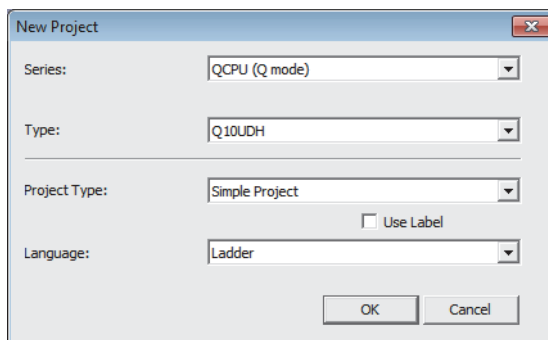

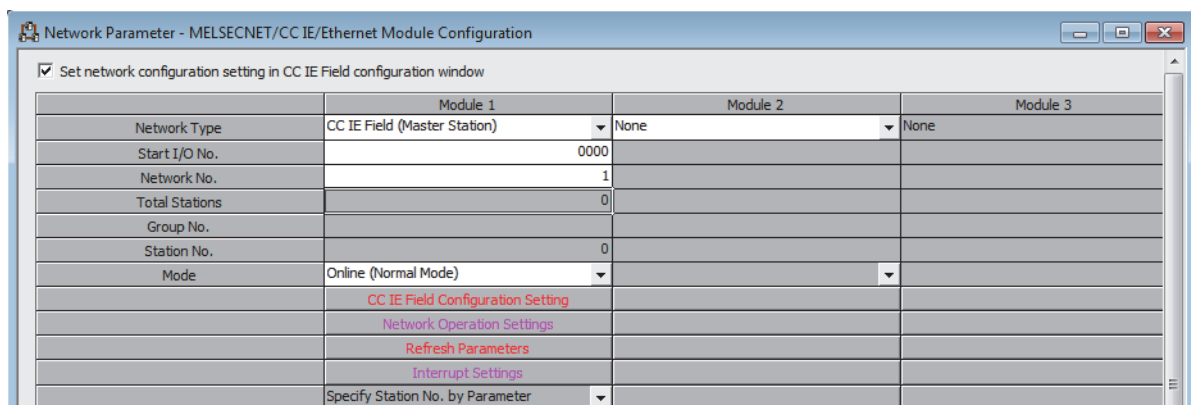

2. Open the network parameter setting window and configure the settings as shown below.

 Project window ⇒ [Parameter] ⇒ [Network Parameter] ⇒ [Ethernet/CC IE/MELSECNET]



- Open the CC IE Field Configuration window and set up the configuration and station number of a slave station as shown below.

  button

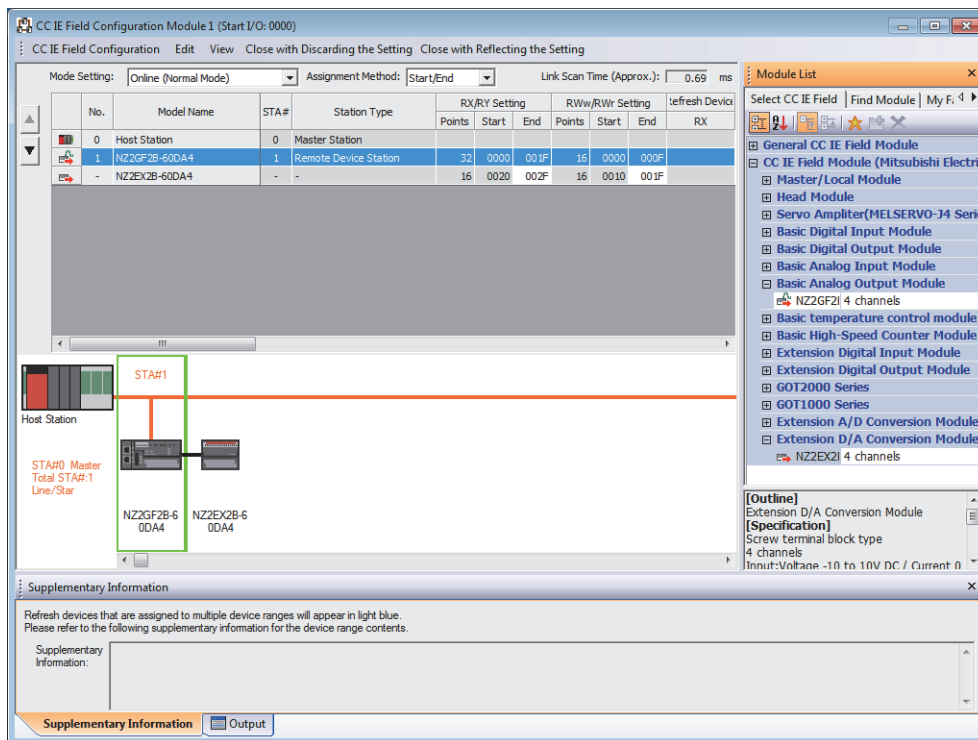

- Close the "CC IE Field Configuration" window.

 [CC IE Field Configuration] ⇒ [Close with Reflecting the Setting]

- Open the refresh parameter setting window and configure the settings as shown below.

  button

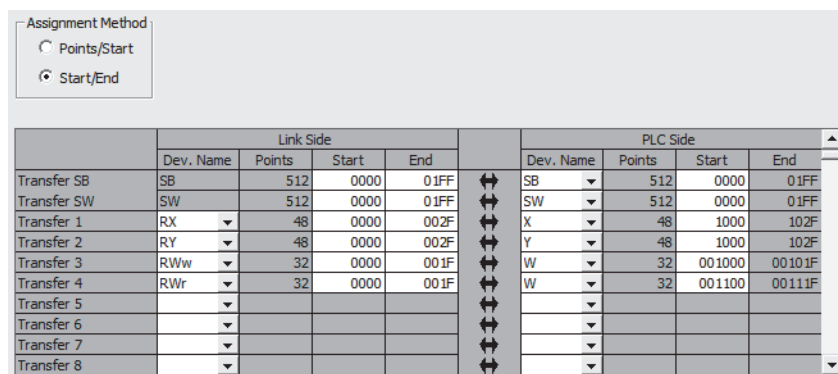

- Write the set parameters to the CPU module of the master station, and reset the CPU module, or turn off and on the power supply.

 [Online] ⇒ [Write to PLC...]

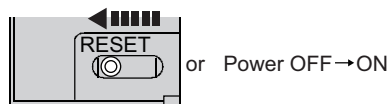

7. Open the "Parameter Processing of Slave Station" window.

- Project window ⇒ [Parameter] ⇒ [Network Parameter] ⇒ [Ethernet/CC IE/MELSECNET] ⇒ **CC IE Field Configuration Setting** button ⇒ Select the main D/A converter module in "List of stations". ⇒ [CC IE Field Configuration] ⇒ [Online] ⇒ [Parameter Processing of Slave Station]

8. Set "Method selection" to "Parameter write".

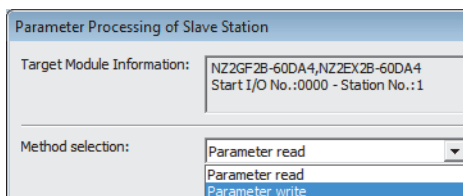

9. Set "Write Value". Follow the next steps to set the value:

- Click the title cell of "Initial Value" to select all the items, and copy them.
- Click the title cell of "Write Value" to select all the items, and paste the copy.
- Select the items to be changed, and set new values as described in Initial settings (Page 140, Section 9.3 (3)).

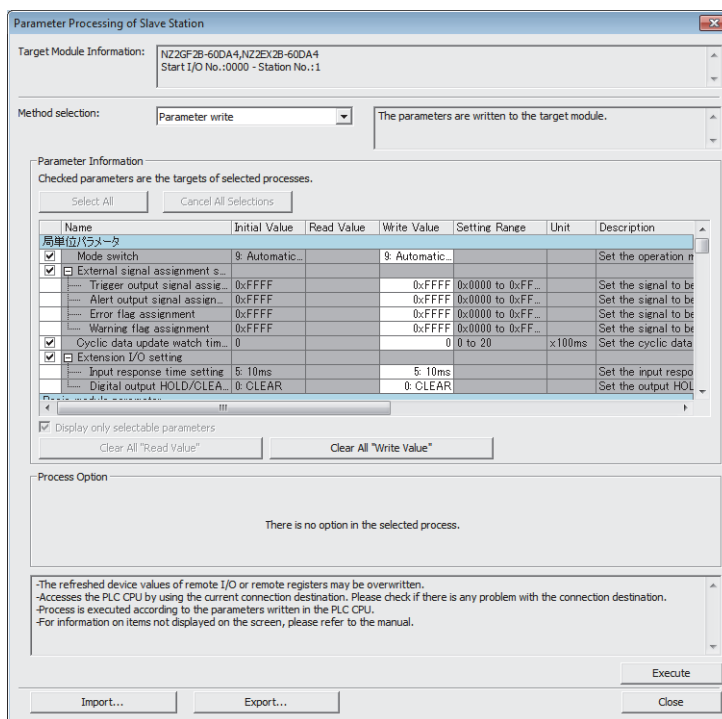

10. Click **Execute button to write the parameters to the D/A converter module.**

(6) Program example

1. Create the following programs with GX Works2.

- Program for the main D/A converter module

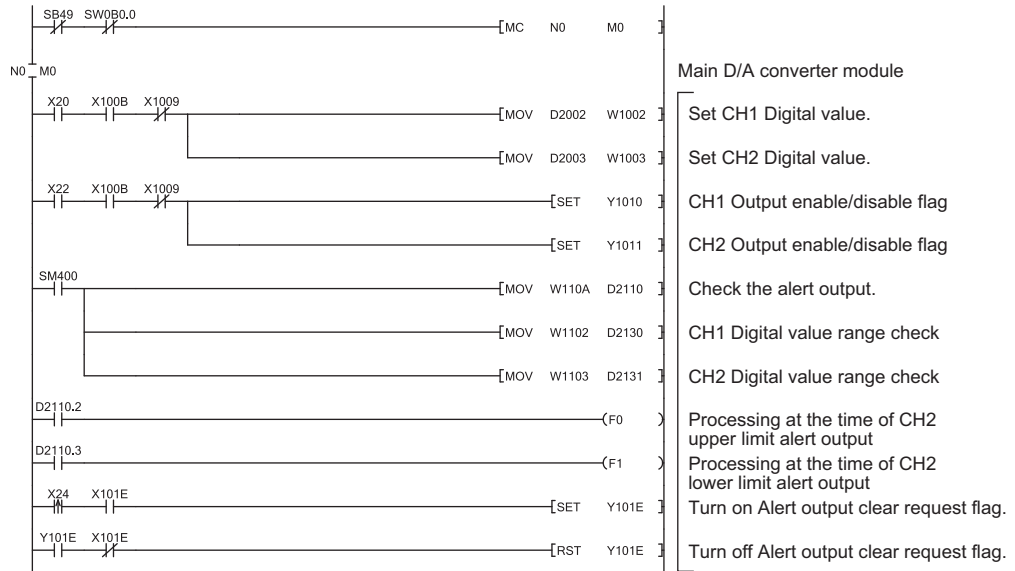

- Program for the extension D/A converter module

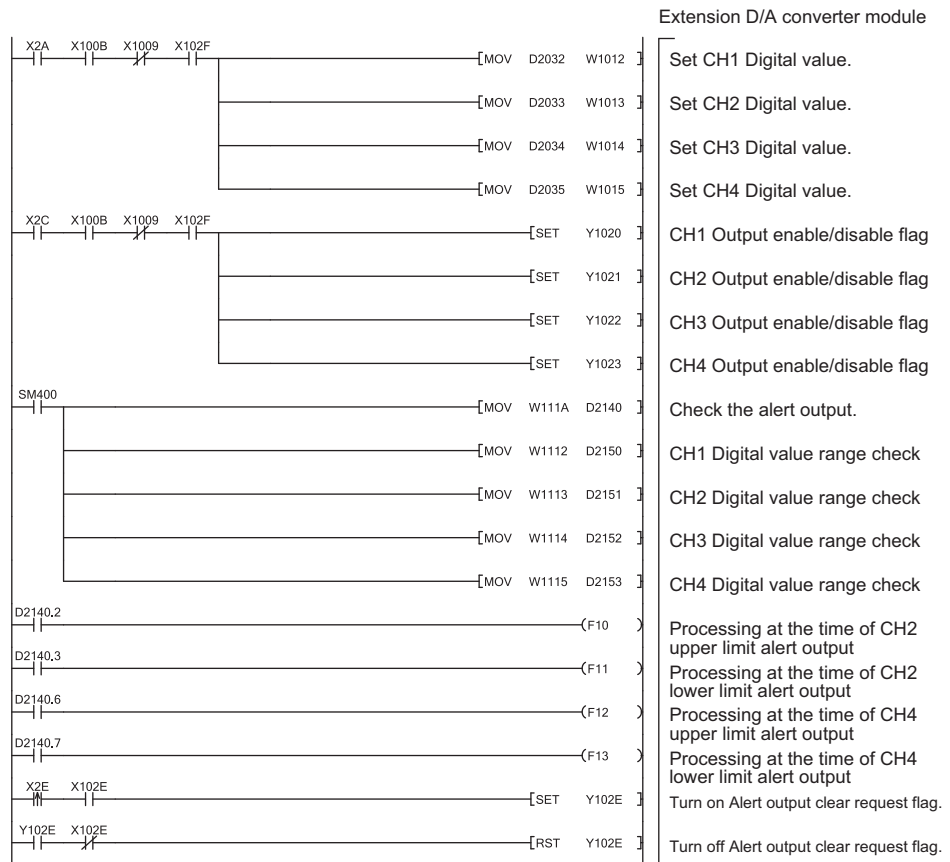

- Program for the common parts

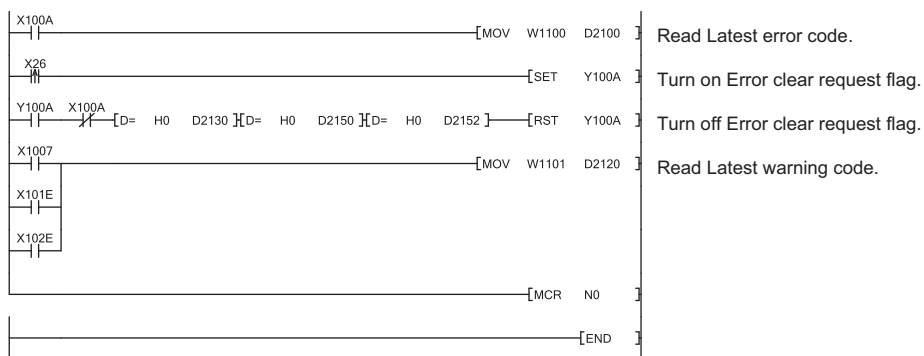

Point

If the master station does not receive a response for several link scans from the D/A converter module, it is recognized as a cyclic transmission faulty station, resulting in the corresponding bit of the data link status of each station (SW00B0 to SW00B7) turning on.

2. Write the programs to the CPU module of the master station, and reset the CPU module, or turn off and on the power supply.

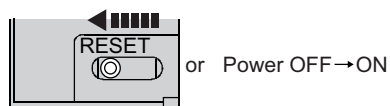

3. Put the CPU module of the master station into RUN.

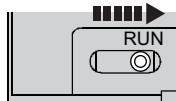

CHAPTER 10 MAINTENANCE AND INSPECTION

There are no special inspection item as a D/A converter module; however, to maintain the best condition of the system, perform the inspection in accordance with the items described in the user's manual for the CPU module used.

Memo

CHAPTER 11 TROUBLESHOOTING

This chapter describes errors that may occur while the D/A converter module is used, and those troubleshooting.

11.1 How to Check Error Codes and Alarm Codes

Error codes can be checked by any of the following methods:

- Checking by executing a command of the slave station (☞ Page 150, Section 11.1 (1))
- Checking by Latest error code (RWr0) (☞ Page 153, Section 11.1 (2))
- Checking by Latest warning code (RWr1) (☞ Page 153, Section 11.1 (3))

Alarm codes can be checked by any of the following methods:

- Checking by executing a command of the slave station (☞ Page 150, Section 11.1 (1))
- Checking by Latest warning code (RWr1) (☞ Page 153, Section 11.1 (3))

(1) Checking by executing a command of the slave station

The procedure below shows how to check the errors by executing a command of the slave station.

1. On the "CC IE Field Configuration" window, from "List of stations", select the main D/A converter module.

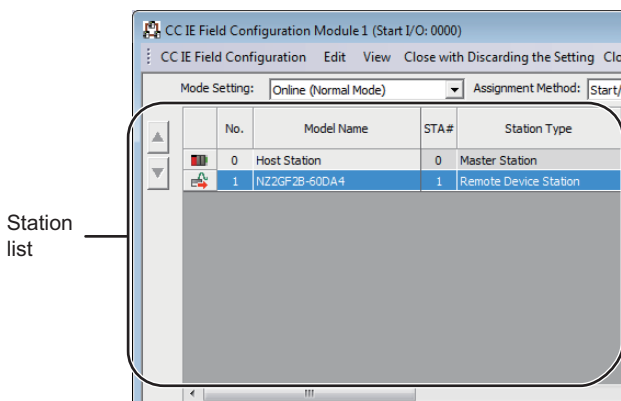

2. Open the "Command Execution of Slave Station" window.

☞ [CC IE Field Configuration] ⇒ [Online] ⇒ [Command Execution of Slave Station]

3. Set "Method selection" to "Error history read" and click **Execute** button.

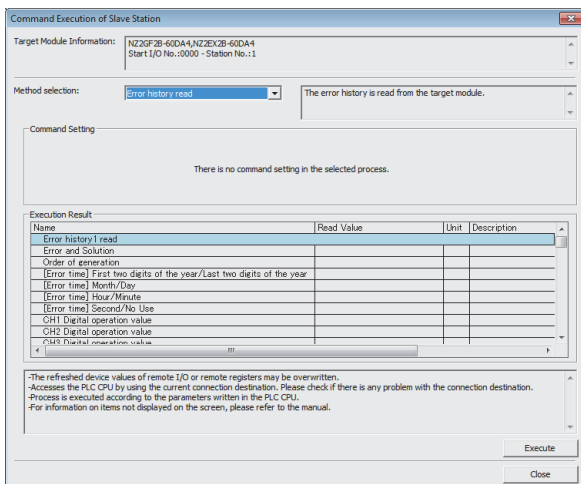

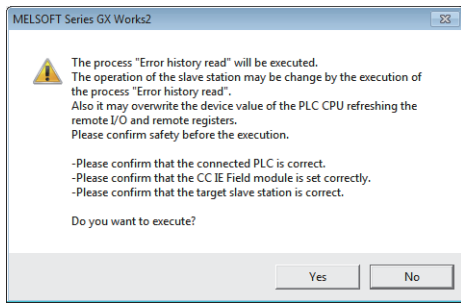

4. In the window that appears (shown left), click **Yes** button.

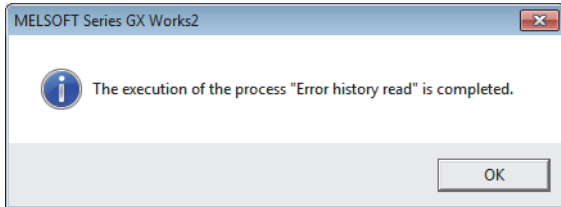

5. In the window that appears (shown left), click **OK** button.

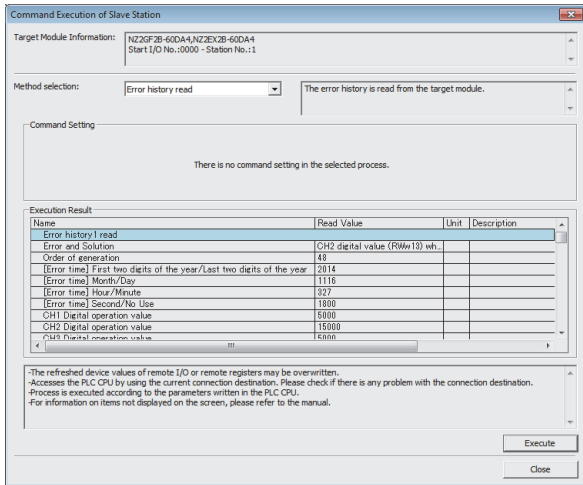

6. The error history of the main D/A converter module and the extension module is displayed in **"Execution Result"**.

Item	Storage contents
Error and Solution	Shows how to take the appropriate action for the error that has occurred.
Order of generation	Shows the order of error occurrence. (A value in the range of 0 to 65535 is stored.)
[Error time] First two digits of the year/Last two digits of the year	Shows the date and time of error occurrence. (When the tens place of Month, Hour and Second is "0", "0" is omitted.)
[Error time] Month/Day	
[Error time] Hour/Minute	
[Error time] Second/No Use	
CH1 Digital value	Stores the value in CH□ Digital value (RWw2 to RWw5, RWw12 to RWw15) at the time of occurrence of an error.
CH2 Digital value	
CH3 Digital value	
CH4 Digital value	

- The error history registers 15 errors at a maximum. If 16 or more errors occur, errors are deleted from the oldest.
- If the same error occurs continuously, only the first error is stored to the error history.
- Even after the module power supply is turned off and on, the error history remains.
- The clock information of occurred error is based on the clock information acquired from the CPU module of the master station. To obtain the accurate data and time of an error, synchronize the clock information of the CPU module to the real time.
- Reading the error history of this module requires the CPU module to be in the STOP status. With the RUN status, the read would fail.
- To initialize the error history, go to the "Command Execution of Slave Station" window to set "Method selection" to "Error history clear request", and then click  button.

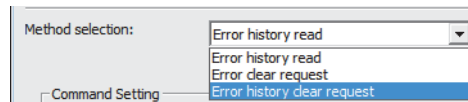

(2) Checking by Latest error code (RWr0)

Check the error with the remote register of the master/local module.

 [Online] ⇒ [Monitor] ⇒ [Device/Buffer Memory Batch]

Ex. When the refresh target device for Latest error code (RWr0) is W1100

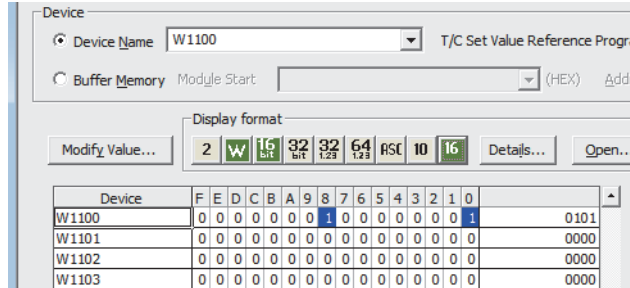

(3) Checking by Latest warning code (RWr1)

Check the warning with the remote register of the master/local module.

 [Online] ⇒ [Monitor] ⇒ [Device/Buffer Memory Batch]

Ex. When the refresh target device for Latest warning code (RWr1) is W1101

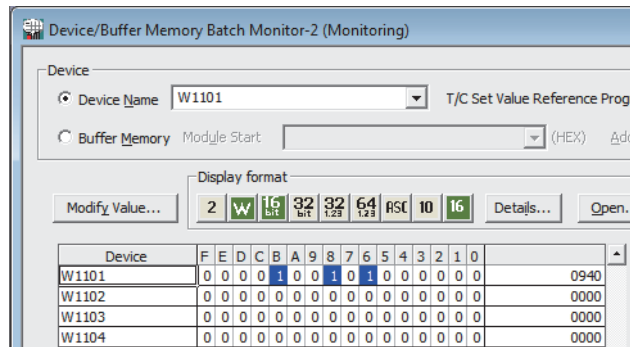

11.2 Error Code List

This section describes error codes.

Error codes are classified by error number as follows.

Error code	Classification	Reference
0000H to 0FFFH, 1F00H to 1F40H, D529H, D52BH	Errors relating to the main D/A converter module	Page 154, Section 11.2.1 (1)
1000H to 1FFFH	Errors relating to the extension D/A converter module	Page 159, Section 11.2.2 (1)
D000H to DFFFH (D529H and D52BH excluded)	Errors relating to the CC-Link IE Field Network (communication error)	Page 158, Section 11.2.1 (2)

11.2.1 Main D/A converter module

(1) Error code list (0000H to 0FFFH, 1F00H to 1F40H, D529H, D52BH)

The errors are classified into the following three types:

Classification	Description
Major error	This error is a sign that recovery is impossible, with the RUN LED turning off.
Moderate error	This error is a sign that the module cannot continue to operate, with the ERR. LED turning on.
Minor error	This error is a sign that the module can continue to operate, with the ERR. LED flashing.

If any of these errors occurs, check that the D LINK LED lights up, and take the corrective actions corresponding to the error code with the list below.

Error code (hexadecimal)	Classification	Error name	Description and cause	Action
0010H	Major error	Hardware failure	Module hardware error	Turn off and on the module power supply. If this error persists, the failure of the module is a possible cause. Please consult your local Mitsubishi representative.
010□H	Moderate error	Range setting out-of-range	The value set in Range setting (address: 0103H) is out of the range. □ indicates the number of the channel that has been incorrectly set.	Set the value of Range setting (address: 0103H) within the allowable range.
0110H ^{*1}	Moderate error	Non-volatile memory data error (module working information)	The non-volatile memory data are abnormal.	<ul style="list-style-type: none"> To set the module operation information of the non-volatile memory back to its default, change Module operation information initialization command (address: 1004H) as follows: Not commanded (0)→Commanded (1) →Not commanded (0). Take anti-noise measures including the use of shielded cables for connection. If this error persists, the failure of the module is a possible cause. Please consult your local Mitsubishi representative.
0120H ^{*1}	Moderate error	User range data damaged (The channel cannot be identified.)	The value set in the offset/gain setting is invalid. The channel where the error has occurred cannot be identified.	Start over the offset/gain setting of all channels where the user range setting is used. If an error occurs, please consult your local Mitsubishi representative.

Error code (hexadecimal)	Classification	Error name	Description and cause	Action
0130H	Moderate error	Non-volatile memory data error (parameter)	The parameter data stored in the non-volatile memory are abnormal.	<ul style="list-style-type: none"> To set the parameters of the non-volatile memory back to their default, change Parameter information clear request (address: 1002H) as follows: Not commanded (0)→Commanded (1)→Not commanded. Set the parameters again. Take anti-noise measures including the use of shielded cables for connection. If this error persists, the failure of the module is a possible cause. Please consult your local Mitsubishi representative.
0140H	Minor error	Non-volatile memory data error (error history)	The error history data stored in the non-volatile memory are abnormal.	<ul style="list-style-type: none"> The module will be automatically recovered immediately after the error occurs. Note that the error history of the errors that have occurred will be lost. Take anti-noise measures including the use of shielded cables for connection. If this error persists, the failure of the module is a possible cause. Please consult your local Mitsubishi representative.
0150H	Minor error	Incorrect network parameter access error	With the network parameters in an incorrect status, the D/A converter module has been accessed.	Set the network parameters correctly.
0160H	Minor error	Remote buffer memory access error	A buffer memory area other than the remote buffer memory areas has been accessed using the REMFR/REMTO instruction.	Correct the set data of the REMFR/REMTO instruction to access the remote buffer memory.
017△H ^{*1}	Moderate error	External signal assignment setting error	An address other than those assigned to the extension I/O module has been set for the external signal assignment function. △ indicates a type of the following errors: 0: Trigger output function 2: Alert output function 3: Error output 4: Warning output	Adjust the external signal assignment function to fall within the addresses assigned to the extension I/O module.
0180H	Moderate error	Same address for the external signal assignment function	The same address has been set in multiple extension output modules for the external signal assignment function.	Set a unique address.
040□H ^{*1}	Moderate error	Offset/gain setting value inversion	The user range setting value has been set to a value where the offset value is equal to or greater than the gain value. □ indicates the number of the channel where an error has occurred.	Correct the setting so that the offset value is smaller than the gain value.
062□H ^{*1}	Moderate error	Alert output upper/lower limit value inversion	The alert output lower limit value has been set equal to or greater than the alert output upper limit value in CH1 Alert output upper limit value (address: 0106H) to CH4 Alert output lower limit value (address: 010DH). □ indicates the number of the channel where an error has occurred.	Correct the settings of CH1 Alert output upper limit value (address: 0106H) to CH4 Alert output lower limit value (address: 010DH) so that the alert output lower limit value is smaller than the alert output upper limit value.
0730H	Moderate error	Mode switch setting error	A value out of the range is set in mode switch (address: 0000H).	Reset the mode switch (address: 0000H) to either of the following: <ul style="list-style-type: none"> Normal conversion mode (0H) Trigger output mode (1H) Automatic judgment mode (9H)
090□H ^{*1}	Moderate error	Scaling setting out-of-range	The values set in CH1 Scaling lower limit value (address: 010FH) to CH4 Scaling upper limit value (address: 0116H) are out of the range of -32000 to 32000. □ indicates the number of the channel where an error has occurred.	Set a value within the range of -32000 to 32000 in CH1 Scaling lower limit value (address: 010FH) to CH4 Scaling upper limit value (address: 0116H).

Error code (hexadecimal)	Classification	Error name	Description and cause	Action
091□H ^{*1}	Moderate error	Scaling upper/lower limit value inversion	The scaling lower limit value has been set equal to or greater than the scaling upper limit value in CH1 Scaling lower limit value (address: 010FH) to CH4 Scaling upper limit value (address: 0116H). □ indicates the number of the channel where an error has occurred.	Correct the settings of CH1 Scaling lower limit value (address: 010FH) to CH4 Scaling upper limit value (address: 0116H) so that the scaling lower limit value is smaller than the scaling upper limit value.
0920H ^{*2}	Minor error	Mode switch setting change	The value set in Mode switch (address: 0000H) has been changed.	Turn off and on the module power supply to operate the module as specified in Mode switch (address: 0000H).
0930H	Moderate error	Cyclic data update watch time setting out-of-range	The value set in Cyclic data update watch time (address: 0007H) is out of the range of 0 to 20.	Set a value within the range of 0 to 20 in Cyclic data update watch time (address: 0007H).
0940H	Minor error	Station number switch changed error	The setting of the station number switch has been changed while the module power is on.	Set the switch again to the station number that was set up at the power on of the module.
0950H	Moderate error	Clock data out-of-range	The clock data acquired from the CPU module is invalid.	The influence of noise or the hardware failure is a possible cause. If the same error occurs again even after measures have been taken against noise, please consult your local Mitsubishi representative.
0960H	Major error	Communication error 3	An invalid data that involves an altered setting of the communication LSI has been received.	Take measures against noise and reset the module. If the same error occurs again, the hardware failure of the module is a possible cause. Please consult your local Mitsubishi representative.
0970H	Major error	Communication error 4	An invalid data that involves an altered setting of the communication LSI has been received.	Take measures against noise and reset the module. If the same error occurs again, the hardware failure of the module is a possible cause. Please consult your local Mitsubishi representative.
0E00H ^{*3}	Moderate error	RWw/RWr setting error	In synchronous communication mode, RWwF/RWrF has not been set in the RWw/RWr setting.	In the RWw/RWr setting of the network parameters, assign RWwF/RWrF again and then turn off and on the power supply, or perform remote reset.
0E10H ^{*3}	Moderate error	Synchronous communication error 1	Synchronous communication with the master station has failed for a certain period of time.	Take the following actions and then turn off and on the power supply, or perform remote reset: • Change the synchronization period of the master station to a longer period. Alternatively, reduce the number of slave stations being active in synchronous communication mode. • Taking measures against noise on the transmission path
0E20H ^{*3}	Moderate error	Synchronization period setting error	The synchronization period set in the master station is not supported by the D/A converter module.	Adjust the synchronization period of the master station and then turn off and on the power supply of the D/A converter module, or perform remote reset.
0E30H ^{*3}	Moderate error	Synchronous communication error 2	Synchronous communication with the master station has failed for a certain period of time.	Take measures against noise on the transmission path and then turn off and on the module power supply, or perform remote reset.
1F00H	Major error	Extension module connection error	The extension module is not connected properly or the connected extension module itself is not supported.	Check the contact state of the extension module and whether the extension module is a connectable module. If the same error occurs again, the failure of the module is a possible cause. Please consult your local Mitsubishi representative.
1F20H	Moderate error	External power supply OFF error	The external power supply monitoring function is enabled; however, the external power supply of the extension output module is in an off state.	• Check the state of the external power supply of the extension output module. • If an error occurs at the system startup or the system stop, correct the timing to enable the external power supply monitoring function.



Error code (hexadecimal)	Classification	Error name	Description and cause	Action
1F30H	Moderate error	Extension module parameter error	The parameter of the model name that is different from the model name of the connected extension module has been reflected.	Set the same type and number of points in Extension module identification code (address: 0200H) as those of the connected extension module.
1F40H	Moderate error	Input response time setting error	In the low 3 bits of Input response time setting (address: 0010H), 000b or 001b has been set.	Set a value other than 000b and 001b to the low 3 bits of Input response time setting (address: 0010H).
D529H	Major error	Communication error 1	An error has occurred in the communication.	<ul style="list-style-type: none"> The malfunction due to noise or other factors is a possible cause. Check the distance of the wire and cables and the grounding condition of the individual devices, and then take measures against noise. Execute a unit test for the module. If the same error occurs again, the hardware failure of the module is a possible cause. Please consult your local Mitsubishi representative.
D52BH	Major error	Communication error 2		

- *1 To clear the error, modify the set value within the range and perform one of the following two operations:
- Turning on and off Error clear request flag (RYA).
 - Turning on and off Initial data setting request flag (RY9).
- *2 Mode switch setting change (error code: 0920H) is not cleared even if five seconds has passed since the error occurred. During the error, the operation continues in the mode previous to the change of Mode switch (address: 0000H). To clear the error staying in the previous mode, set Mode switch (address: 0000H) back to the original value and then turn on and off Initial data setting request flag (RY9).
- *3 Turning on and off Error clear request flag (RYA) or Initial data setting request flag (RY9) does not clear this error. The error is cleared only by the method described in the action column.

Point

In the event of multiple errors, only the latest error code is stored in Latest error code (RWr0) or Latest warning code (RWr1). The errors that have occurred in the past can be checked in the error history of the engineering tool.

For the error history, refer to the following:

- Checking by executing a command of the slave station ( Page 150, Section 11.1 (1))
- Error history data  ( Page 198, Appendix 3 (17))

(2) Error code list (D000H to DFFFH (D529H and D52BH excluded))

While any of these errors occurs, the ERR. LED does not turn on. Based on the behavior of the D LINK LED at the occurrence of an error, the errors are classified into two types, each of which requires different troubleshooting.

(a) Communication errors where the D LINK LED flashes or turns off

This type of communication error results in the D LINK LED flashing or turning off. Troubleshoot the problem with the CC-Link IE Field Network diagnostics. ( Page 135, Section 8.17)

Error code (hexadecimal)	Error name	Description and cause	Action
D0E0H	Station type mismatch	The network parameters are incorrect or out of the range.	In the network configuration settings of the master station, change the station type of the module to the remote device station.
D0E1H	Own station set to reserved station	The network parameters are incorrect or out of the range.	<ul style="list-style-type: none"> In the network configuration settings of the master station, cancel the reserved station specification. Change the station number of the module to a station number that is not specified as a reserved station.
D0E2H	Own station station number duplication error	The settings of the station number switch are invalid or out of the range.	<ul style="list-style-type: none"> Change the station number avoiding duplication of the station number with other stations. After taking the above action, power off and on or reset all the stations where a station number duplication error has been detected.
D0E3H	Own station station number out-of-range	The network parameters are incorrect or out of the range.	Add the station information of the module to the network configuration settings of the master station.
D72AH	Station number switch out-of-range (a value other than 1 to 120)	A station number out of the range has been set.	Set the station number within the allowable range.

(b) Communication errors where the D LINK LED does not change

This type of communication error results in no change of the D LINK LED. These errors are not shown in CC-Link IE Field Network diagnostics because they are automatically recovered after the occurrence.



Troubleshooting them requires the error history to be read out. ( Page 150, Section 11.1 (1))

Error code (hexadecimal)	Error name	Description and cause	Action
D217H	Transient data request command error	The transient data request command is incorrect.	Correct the request command at the transient request source, and retry the execution.
D2A0H	Receive buffer full error	There is an overload of the received transient data.	<ul style="list-style-type: none"> Check the network status using CC-Link IE Field Network diagnostics of the engineering tool to take the appropriate action. If the received transient data of the target station is overloaded, send the data after the send source passes for a while.
D2A3H	Transient data length error	The received transient data is incorrect.	Correct the number of data (frame length) at the transient request source, and retry the execution.
DF01H	Received transient split error	The split transient data has been received.	Set the transient data size that the module can accommodate, and modify the transient data to the one that is not split. Then send it again.

Point

In the event of multiple errors, only the latest error code is stored in Latest error code (RWr0) or Latest warning code (RWr1). The errors that have occurred in the past can be checked in the error history of the engineering tool.

For the error history, refer to the following:

- Checking by executing a command of the slave station ( Page 150, Section 11.1 (1))
- Error history data  ( Page 198, Appendix 3 (17))

11.2.2 Extension D/A converter module

(1) Error code list (1000H to 1FFFH)

The errors are classified into the following three types:

Classification	Description
Major error	This error is a sign that recovery is impossible, with the RUN LED turning off.
Moderate error	This error is a sign that the module cannot continue to operate, with the ERR. LED of the main analog module turning on.
Minor error	This error is a sign that the module can continue to operate, with the ERR. LED of the main analog module flashing.

If any of these errors occurs, check that the D LINK LED lights up, and take the corrective actions corresponding to the error code with the list below.

Error code (hexadecimal)	Classification	Error name	Description and cause	Action
1010H	Major error	Hardware failure	Module hardware error	Turn off and on the module power supply. If this error persists, the failure of the module is a possible cause. Please consult your local Mitsubishi representative.
110□H	Moderate error	Range setting out-of-range	The value set in Range setting (address: 0203H) is out of the range. □ indicates the number of the channel that has been incorrectly set.	Adjust the value of Range setting (address: 0203H) to fall within the range.
161□H ^{*1}	Moderate error	Alert output upper/lower limit value inversion	The alert output lower limit value has been set equal to or greater than the alert output upper limit value in CH1 Alert output upper limit value (address: 0206H) to CH4 Alert output lower limit value (address: 020DH). □ indicates the number of the channel where an error has occurred.	Correct the settings of CH1 Alert output upper limit value (address: 0206H) to CH4 Alert output lower limit value (address: 020DH) so that the alert output lower limit value is smaller than the alert output upper limit value.
190□H ^{*1}	Moderate error	Scaling setting out-of-range	The values set in CH1 Scaling lower limit value (address: 020FH) to CH4 Scaling upper limit value (address: 0216H) are out of the range of -32000 to 32000. □ indicates the number of the channel where an error has occurred.	Adjust CH1 Scaling lower limit value (address: 020FH) to CH4 Scaling upper limit value (address: 0216H) to fall within the range of -32000 to 32000.
191□H ^{*1}	Moderate error	Scaling setting upper/lower limit inversion	CH1 Scaling lower limit value (address: 020FH) to CH4 Scaling upper limit value (address: 0216H) have been set as follows: Scaling lower limit value ≥ Scaling upper limit value. □ indicates the number of the channel where an error has occurred.	Adjust the settings of CH1 Scaling lower limit value (address: 020FH) to CH4 Scaling upper limit value (address: 0216H) as follows: Scaling lower limit value < Scaling upper limit value.
1F00H	Major error	Extension module connection error	The extension module is not connected properly or the connected extension module itself is not supported.	Check the contact state of the extension module and whether the extension module is a connectable module. If the same error occurs again, the failure of the module is a possible cause. Please consult your local Mitsubishi representative.
1F30H	Moderate error	Extension module parameter error	The model name reflecting the parameter is different from that of the connected extension module.	Adjust Extension module identification code (address: 0200H) to match the type and the number of points with the connected extension module.
1F50H	Major error	Extension analog module receive data error	The data received from the extension analog module is abnormal.	<ul style="list-style-type: none"> Poor contact of the extension analog module or the influence of noise is a possible cause. If the error persists even after contact check and anti-noise action, the failure of the module is a possible cause. Please consult your local Mitsubishi representative.



Error code (hexadecimal)	Classification	Error name	Description and cause	Action
1F60H	Major error	Extension analog module send data error	The data sent to the extension analog module is abnormal.	<ul style="list-style-type: none"> Poor contact of the extension analog module or the influence of noise is a possible cause. If the error persists even after contact check and anti-noise action, the failure of the module is a possible cause. Please consult your local Mitsubishi representative.

- *1 To clear the error, modify the set value within the range and perform one of the following two operations:
- Turning on and off Error clear request flag (RYA).
 - Turning on and off Initial data setting request flag (RY9).

Point!

In the event of multiple errors, only the latest error code is stored in Latest error code (RWr0) or Latest warning code (RWr1). The errors that have occurred in the past can be checked in the error history of the engineering tool.

For the error history, refer to the following:

- Checking by executing a command of the slave station ( Page 150, Section 11.1 (1))
- Error history data□ ( Page 198, Appendix 3 (17))

11.3 Alarm Code List

11.3.1 Main D/A converter module

Here is the list of alarm codes:

Alarm code (hexadecimal)	Category	Alarm name	Description and cause	Action
060□H*1	Minor error	Digital value out-of-range	The value set in CH□ Digital value (RWw2 to RWw5) is out of the range. □ indicates the number of the channel where this alarm has occurred.	Adjust the value of CH□ Digital value (RWw2 to RWw5) to fall within the setting range of the set output range.
0A△□H	Minor error	Alert occurrence	An alert is occurring. □ indicates the number of the channel where an alert has been issued. △ indicates the status as follows: 0: Upper limit alert 1: Lower limit alert	Adjust the digital value to fall within the range, and turn on and off Alert output clear request flag (RY1E).

- *1 To clear the alarm, adjust the set value within the range and perform one of the following two operations:
- Turning on and off Error clear request flag (RYA).
 - Turning on and off Initial data setting request flag (RY9).

11.3.2 Extension D/A converter module

Here is the list of alarm codes:

Alarm code (hexadecimal)	Classification	Alarm name	Description and cause	Action
160□H*1	Minor error	Digital value out-of-range	The value set in CH□ Digital value (RWw12 to RWw15) is out of the range. □ indicates the number of the channel where this alarm has occurred.	Adjust the value of CH□ Digital value (RWw12 to RWw15) to fall within the setting range of the set output range.
1C△□H	Minor error	Alert occurrence	An alert is occurring. □ indicates the number of the channel where an alert has been issued. △ indicates the status as follows: 0: Upper limit alert 1: Lower limit alert	Adjust the digital value to fall within the range, and turn on and off Alert output clear request flag (RY2E).

- *1 To clear the alarm, adjust the set value within the range and perform one of the following two operations:
- Turning on and off Error clear request flag (RYA).
 - Turning on and off Initial data setting request flag (RY9).

11.4 Checking the LEDs

This section describes how to troubleshoot the system by the LEDs.

Point

For the troubleshooting using the LEDs of the extension I/O module, refer to the following:

☞ CC-Link IE Field Network Remote I/O Module User's Manual

For the troubleshooting using the LEDs of the extension A/D converter module, refer to the following:

☞ CC-Link IE Field Network Analog-Digital Converter Module User's Manual

11.4.1 Main D/A converter module

(1) When the PW LED does not turn on

Check item	Action
Is any LED other than the PW LED turned on?	If any LED other than the PW LED turns on, the hardware failure is a possible cause. Please consult your local Mitsubishi representative.
Is the module power supply (24VDC) wired?	Carry out the wiring of the module power supply (24VDC).
Is the module power supply (24VDC) supplied?	Supply the module power supply (24VDC).
Does the voltage of the module power supply (24VDC) conform to the specified range?	Adjust the voltage value to conform to the range of performance specifications.

(2) When the RUN LED does not turn on

Check item	Action
Does the voltage of the module power supplied externally reach to the voltage of the performance specifications?	Verify that the voltage of the module power supply lies in the range of performance specifications. (☞ Page 24, Section 3.2)
Does any hardware error occur?	After the check, turn off and on the module power supply. If the RUN LED does not turn on even after the module power supply is turned from off to on, the failure of the module is a possible cause. Please consult your local Mitsubishi representative.



(3) When the MODE LED flashes

Check item	Action
Is the main D/A converter module in the unit test?	When the main D/A converter module is in the unit test, the MODE LED turns off after the unit test is completed. Take corrective action according to the result of the unit test. (☞ Page 166, Section 11.5)

(4) When the MODE LED turns off

Check item	Action
Is the main D/A converter module in offset/gain setting mode?	When the main D/A converter module is in offset/gain setting, change the mode to normal mode after the offset/gain setting is completed.
Does any hardware error occur?	If the MODE LED does not turn on even after the module power supply is turned on from off, the hardware failure is a possible cause. Please consult your local Mitsubishi representative.

(5) When the D LINK LED turns off

Check item	Action
Does the own station in network operate normally?	Connect the engineering tool to the master station, and then check if a data link is established in the own station by using CC-Link IE Field Network diagnostics. ( User's manual for the master/local module used)
Are 1000BASE-T-compliant Ethernet cables used?	Replace the cable with a 1000BASE-T-compliant Ethernet cable. ( User's manual for the master/local module used)
Is the station-to-station distance 100m or less?	Change the station-to-station distance to 100m or less.
Does the cabling condition (bend radius) meet the specifications?	Refer to the manual for the Ethernet cable used, and correct the bend radius.
Is any Ethernet cable disconnected?	Replace the Ethernet cable.
Do other stations connected to the main D/A converter module operate normally?	Check if the power supplies of the other stations are turned on.
Does the switching hub normally operate?	<ul style="list-style-type: none"> • Check if a 1000BASE-T-compliant switching hub is used. ( User's manual for the master/local module used) • Check if the power supply of the switching hub is turned on.
Does the station number of the main D/A converter module overlap with the other stations?	Two or more stations are overlapping. Change the setting so that all the station numbers differ.

(6) When the D LINK LED flashes

Check item	Action
Does the set station number of the main D/A converter module match the station number of the main D/A converter module that is set up in the network configuration settings of the master station or in the CC IE Field configuration?	Match the station number of the main D/A converter module with the station number that is set up in the network configuration settings of the master station or in the CC IE Field configuration.
Is the station type remote device station?	Change the station type of the module to the remote device station in the network configuration settings of the master station.
Is the A/D converter module a reserved station?	Change the setting of reserved/ignored error station to other than the reserved station in the network configuration settings of the master station.
Is stop of the data link checked through CC-Link IE Field Network diagnostics?	Check the link status through CC-Link IE Field Network diagnostics and start the link when the data link is stopped.
Is the station number switch set to other than 1 to 120?	The setting range for the station number switch is 1 to 120. Set the number from 1 to 120.
Has the connection been changed to the other master station with a different network number?	<ul style="list-style-type: none"> • Correct the connection to the previous master station. • To communicate with the master station with a different network number, power off and on the main D/A converter module.

(7) When the L ER LED turns on

Check item	Action
Are Ethernet cables normal?	<ul style="list-style-type: none"> • Check if 1000BASE-T-compliant Ethernet cables are used. (📖 User's manual for the master/local module used) • Check if the station-to-station distance is 100m or less. • Check if the Ethernet cables are not disconnected.
Does the switching hub used in the system operate normally?	<ul style="list-style-type: none"> • Check if a 1000BASE-T-compliant switching hub is used. (📖 User's manual for the master/local module used) • Check if the power supply of the switching hub is turned on.
Do other stations connected to the main D/A converter module operate normally?	Check if the power supplies of the other stations are turned on.
Is the mode of the master station set to other than Online?	Change the mode of the master station to Online.
Is there any noise affecting the system?	Ground the control panel where the D/A converter module is installed.
Is the loopback function enabled for the master station?	When the loopback function is enabled, check if the ring topology is correctly configured for the port where the L ER LED is on. (📖 User's manual for the master/local module used)

(8) When the LINK LED turns off

Check item	Action
Are Ethernet cables normal?	<ul style="list-style-type: none"> • Check if 1000BASE-T-compliant Ethernet cables are used. (📖 User's manual for the master/local module used) • Check if the station-to-station distance is 100m or less. • Check if the Ethernet cables are not disconnected.
Do the switching hub used in the system and other stations operate normally?	Check if the power supplies of the switching hub and other stations are turned on.

Point

If link-up processing is repeated due to a condition of a device on the line, it may take a longer time for the LINK LED to turn on. This phenomenon may be eliminated by changing the module PORT into which the Ethernet cable is connected (example: PORT1 → PORT2). For the wiring of Ethernet cable, refer to the following.

 Page 60, Section 6.5

(9) When the ERR. LED turns on

Check item	Action
Does any error occur?	Identify the error factor of the D/A converter module with the engineering tool to take corrective action.

(10) When the ALM LED turns on or flashes**(a) When the ALM LED turns on**

Check item	Action
Has an alert been output in the main D/A converter module?	Check Alert output flag (RWrA).
Has an alert been output in the extension D/A converter module?	Check Alert output flag (RWr1A).
Has an alert been output in the extension A/D converter module?	Check Alert output flag (RWr1B).

(b) When the ALM LED flashes

Check item	Action
Has a digital value out-of-range error occurred in the main D/A converter module?	Check Set value check code (RWr2 to RWr5) of the corresponding channel.
Has a digital value out-of-range error occurred in the extension D/A converter module?	Check Set value check code (RWr12 to RWr15) of the corresponding channel.
Has an input signal error occurred in the extension A/D converter module?	Check Input signal error detection flag (RWr1A).

11.4.2 Extension D/A converter module**(1) When the RUN LED flashes**

Check item	Action
Is the external power supply (24VDC) wired?	Carry out the wiring of the external power supply (24VDC).
Is the external power supply (24VDC) supplied?	Supply the external power supply (24VDC).
Does the voltage of the external power supply (24VDC) conform to the specified range?	Adjust the voltage value to conform to the range of performance specifications.

(2) When the RUN LED does not turn on

Check item	Action
Does the main analog module operate in offset/gain setting mode or unit test mode?	If the drive mode of the main analog module is offset/gain setting mode or unit test mode, change the drive mode to another one.
Is the extension D/A converter module properly connected to the main analog module?	<ul style="list-style-type: none"> • If not connected, connect the extension D/A converter module to the main analog module. • If properly connected, refer to the following to verify the connection between the main analog module and the extension D/A converter module: (☞ Page 53, Section 6.3.1) • If the RUN LED does not turn on even after the module power supply of the main analog module is turned off and on, the hardware failure is a possible cause. Please consult your local Mitsubishi representative.
Has a hardware failure occurred in the main analog module or the extension D/A converter module?	<ul style="list-style-type: none"> • Turn off and on the main analog module and extension D/A converter module. • Replace either of the main analog module and the extension D/A converter module with another module. • If this error persists, the hardware failure is a possible cause. Please consult your local Mitsubishi representative.

11.5 Unit Test

The purpose of a unit test is to check if there is any abnormality in the main D/A converter module.

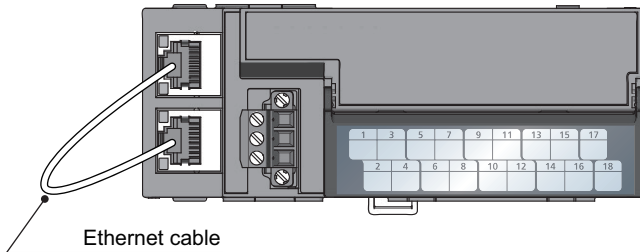

Ethernet cable

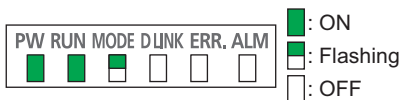
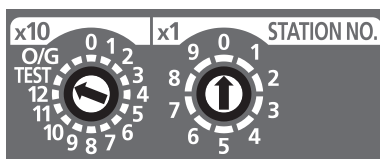

When completed successfully

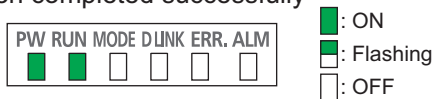

When completed with an error



1. Power off the module.
2. Connect the PORT1 and PORT2 connectors of the main D/A converter module with an Ethernet cable.

3. Set up the station number setting switch as follows:
 - x10: TEST
 - x1: 0

4. Power on the module.

5. Unit test begins.
 - The MODE LED flashes during the unit test.

6. The MODE LED turns off when the unit test is completed.

- When the test is completed normally, the ERR. LED does not turn on, remaining off.
- When the test is completed with an error, the ERR. LED turns on. If the unit test has completed with an error, replace the Ethernet cable and run the test again. If the test is completed with an error again, the hardware failure in the main D/A converter module is a possible cause. Please consult your local Mitsubishi representative.

Remark

When the unit test is completed with an error, the error details can be checked in the error history of the engineering tool. To check the error history with the engineering tool, set the station number of the main D/A converter module and connect the module to the master station with an Ethernet cable.

For the error history, refer to the following:

- Checking by executing a command of the slave station (Page 150, Section 11.1 (1))
- Error history data (Page 198, Appendix 3 (17))

.....

11.6 Troubleshooting by Symptom

This section describes troubleshooting problem by problem.

Troubleshooting by symptom is suitable for the case where modules fail to operate normally even though no error has occurred in the D/A converter module. If an error occurs in the D/A converter module, identify the cause of the error using the engineering tool.

11.6.1 Main D/A converter module

(1) When the analog output value is not output

Check item	Action
Is there any problem with the wiring, such as looseness or disconnection of analog signal lines?	Identify the faulty area of signal lines by a visual check and a continuity check.
Is the CPU module in the STOP status?	Change the status of the CPU module to RUN.
Is the offset/gain setting correct?	Check if the offset/gain setting is correct. If the user range is used, change the output range to any of the default settings, and then check if the D/A conversion is performed properly. If the D/A conversion is properly performed, configure the offset/gain setting again.
Is the output range setting correct?	Verify Range setting (address: 0103H) by using the engineering tool or the dedicated instruction. If the output range setting is incorrect, set the range again by the program or the parameter settings.
Is D/A conversion disabled for the channels where the analog value is to be output?	Check D/A conversion enable/disable setting (address: 0102H) by using the engineering tool or the dedicated instruction. Then, set the D/A conversion to be enabled by the program or the parameter settings.
Is CH□ Output enable/disable flag (RY10 to RY13) set to OFF for the channels where the analog value is to be output?	Check the setting for CH□ Output enable/disable flag (RY10 to RY13) on the monitor of the engineering tool. When CH□ Output enable/disable flag (RY10 to RY13) is in an off state, check the program again.
Is a digital value written to the channel where the analog value is to be output?	Check the setting for CH□ Digital value (RWw2 to RWw5) on the monitor of the engineering tool.
Is Initial data setting request flag (RY9) executed?	Check if the analog value is output properly after turning on and off Initial data setting request flag (RY9) using the engineering tool. If the output is performed properly, check the program again.
Is the network synchronous communication setting (Synchronous or Asynchronous) changed in the network configuration setting?	If the network synchronous communication setting is changed, turn off and on the power or perform remote reset.
Is an inter-module synchronous interrupt program prepared when the CC-Link IE Field Network synchronous communication function is used together with the inter-module synchronization function on the MELSEC iQ-R series?	For the combined use of the CC-Link IE Field Network synchronous communication function and the inter-module synchronization function on the MELSEC iQ-R series, prepare an inter-module synchronous interrupt program. For the inter-module synchronous interrupt program, refer to the following: 📖 MELSEC iQ-R Inter-Module Synchronization Function Reference Manual

Point

If the analog output value cannot be output even after the above actions are taken, the failure of the D/A converter module is a possible cause. Please consult your local Mitsubishi representative.

(2) When the analog output value is not held

Check item	Action
Is the setting for the analog output HOLD/CLEAR function correct?	Set HOLD for the analog output HOLD/CLEAR function using the engineering tool. In addition, check the set value for Analog output HOLD/CLEAR setting (address: 0104H).

(3) When the output status of the extension output module differs from the link device status of the master station

Check item	Action
Is the setting of the external signal assignment function correct?	<p>Check that the following settings are not used in the external signal assignment function.</p> <ul style="list-style-type: none"> • Alert output signal assignment (☞ Page 187, Appendix 3 (3)) • Error flag assignment (☞ Page 188, Appendix 3 (4)) • Warning flag assignment (☞ Page 189, Appendix 3 (5))

(4) When parameter read or write, or CC-Link IE Field Network diagnostics fails by engineering tool

Check item	Action
Is the D LINK LED of the main D/A converter module on?	<p>Check the D LINK LED of the main D/A converter module and if it is not on, perform troubleshooting by referring to the following:</p> <ul style="list-style-type: none"> • When the D LINK LED turns off (☞ Page 163, Section 11.4 (5)) • When the D LINK LED flashes (☞ Page 163, Section 11.4 (6)) <p>Check for other LEDs by referring to the following:</p> <ul style="list-style-type: none"> • Checking the LEDs (☞ Page 162, Section 11.4)
Is the version of the module on the master station correct?	<p>Check the serial number (first five digits) of the module on the master station, and if the version is prior to the correct one, replace the module with a module of the supported version. For the supported version, refer to the following:</p> <ul style="list-style-type: none"> • Supported master station (☞ Page 48, Section 5.2 (1))
Is the version of the engineering tool supported?	<p>Check the version of the engineering tool, and if it is prior to the supported versions, update the engineering tool. For the supported version, refer to the following:</p> <ul style="list-style-type: none"> • Supported software package (☞ Page 49, Section 5.2 (4))
Are network parameter settings same as the settings of the CPU module?	<p>Perform "Verify with PLC" and check that network parameter settings match the settings of the CPU module. If they differ, match the settings by performing "Read from PLC" and "Write to PLC", and write the parameters to modules on slave stations.</p>

11.6.2 Extension D/A converter module

(1) When the analog output value is not output

Check item	Action
Is there any problem with the wiring, such as looseness or disconnection of analog signal lines?	Identify the faulty area of signal lines by a visual check and a continuity check.
Is the CPU module in the STOP status?	Change the status of the CPU module to RUN.
Is the output range setting correct?	Verify Range setting (address: 0203H) by using the engineering tool or the dedicated instruction. If the output range setting is incorrect, set the range again by the program or the parameter settings.
Is D/A conversion disabled for the channels where the analog value is to be output?	Check D/A conversion enable/disable setting (address: 0202H) by using the engineering tool or the dedicated instruction. Then, set the D/A conversion to be enabled by the program or the parameter settings.
Is CH□ Output enable/disable flag (RY20 to RY23) in an off state for the channels where the analog value is to be output?	Check the setting for CH□ Output enable/disable flag (RY20 to RY23) on the monitor of the engineering tool. If CH□ Output enable/disable flag (RY20 to RY23) is in an off state, check the program again.
Is a digital value written to the channel where the analog value is to be output?	Check the setting for CH□ Digital value (RWw12 to RWw15) on the monitor of the engineering tool.
Is External power supply READY flag (RX2F) on?	If the analog output value of the extension D/A converter module is not output, check the status of External power supply READY flag (RX2F). If External power supply READY flag (RX2F) is off, adjust External power supply READY flag (RX2F) to turn on with reference to the following: (Page 176, Appendix 1.1 (8))
Does the main analog module operate in offset/gain setting mode or unit test mode?	If the drive mode of the main analog module is offset/gain setting mode or unit test mode, change the drive mode to another one.

Point

If the analog output value cannot be output even after the above actions are taken, the failure of the D/A converter module is a possible cause. Please consult your local Mitsubishi representative.

(2) When the analog output value is not held

Check item	Action
Is the setting for the analog output HOLD/CLEAR function correct?	Set HOLD for the analog output HOLD/CLEAR function using the engineering tool. In addition, check the set value for Analog output HOLD/CLEAR setting (address: 0204H).

APPENDICES

Appendix 1 Details of Remote I/O Signals

This section describes the details of the remote I/O signals for a master/local module.

The described assignment of device numbers assumes that the remote I/O signals of D/A converter modules are assigned as follows:

Signal name	Main D/A converter module	Extension D/A converter module
Remote input signal	RX0 to RX1F	RX20 to RX2F
Remote output signal	RY0 to RY1F	RY20 to RY2F

Appendix 1.1 Remote input signals

(1) Warning flag

At the occurrence of a minor error, Warning flag (RX7) turns on.

Eliminating the cause of the minor error occurred and waiting for five seconds results in Latest warning code (RWr1) turning to 0000H and Warning flag (RX7) turning off.

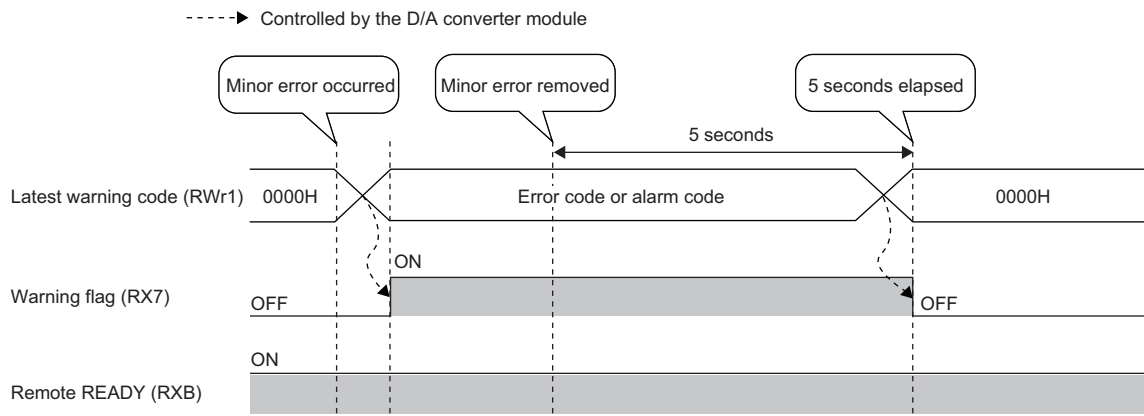

(a) Device number

The device number of this input signal is as follows:

Signal name	Main D/A converter module	Extension D/A converter module
Warning flag	RX7	

(2) Initial data setting completed flag

After writing parameter data to the remote buffer memory using the REMTO instruction, turn on Initial data setting request flag (RY9).

Upon completion of the change of operating conditions, Initial data setting completed flag (RX9) turns on.

For the remote buffer memory items that require Initial data setting request flag (RY9) to be turned on and off to enable written parameter data, refer to the following:

(☞ Page 37, Section 3.7)

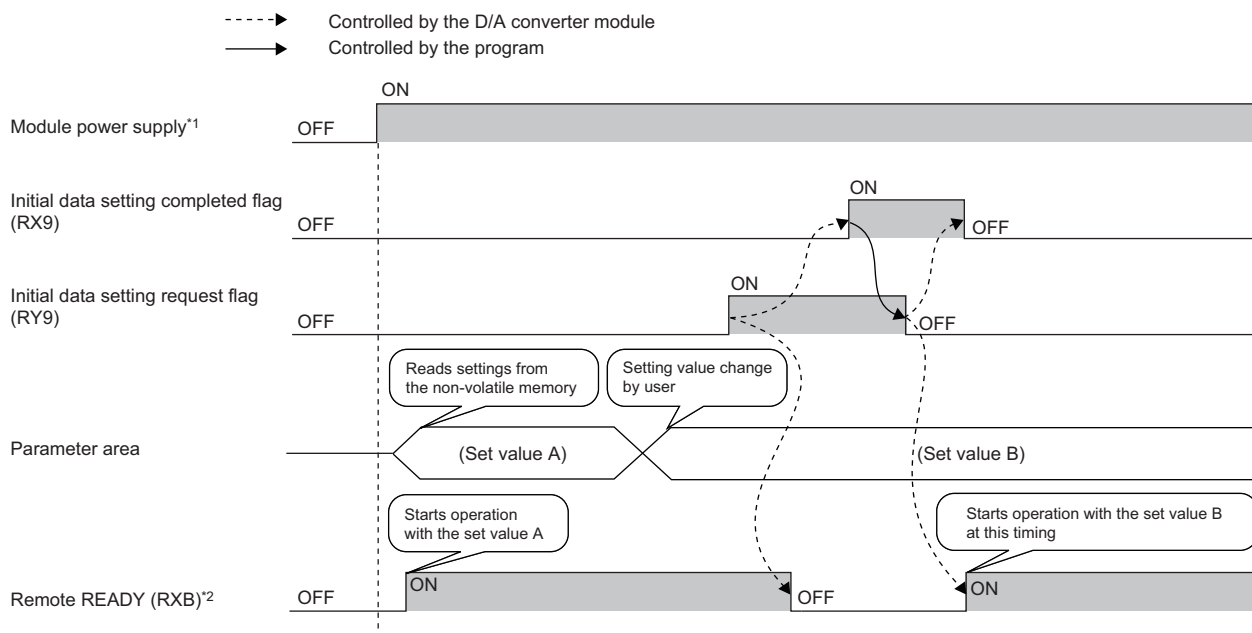

*1 Assume that a data link is established simultaneously with turning on of the module power supply.

*2 If Initial data setting request flag (RY9) is turned on and off, check the turning on of Remote READY (RXB) to start the control.

(a) Device number

The device number of this input signal is as follows:

Signal name	Main D/A converter module	Extension D/A converter module
Initial data setting completed flag	RX9	

(3) Error flag

In the event of a moderate error or a major error, Error flag (RXA) turns on.

To clear Latest error code (RWr0), turn on and off Error clear request flag (RYA).

- With a moderate error

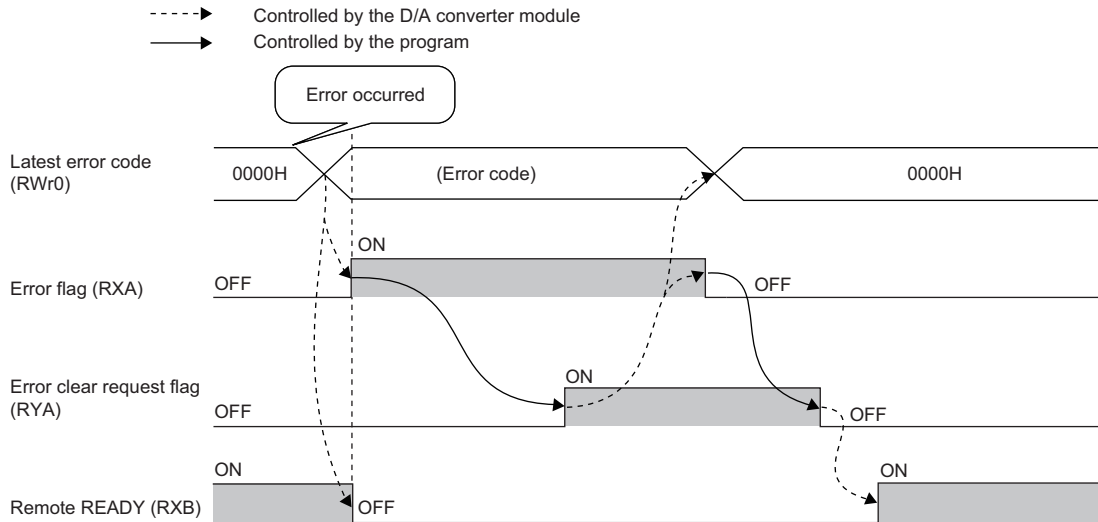

- With a major error

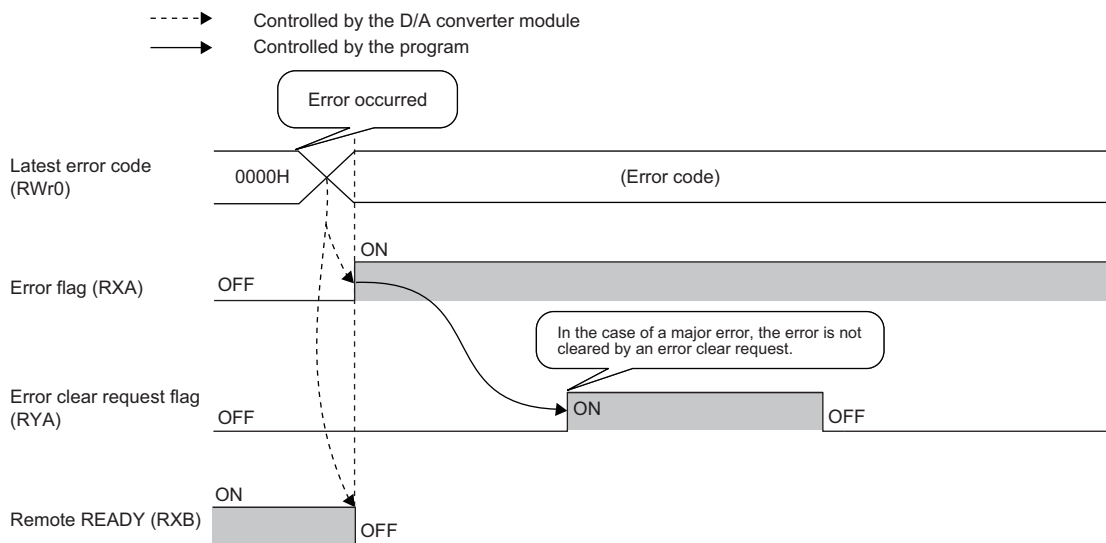

(a) Error history

The error history is not cleared even if Error clear request flag (RYA) is turned on and off. To clear the error history, set "1" in Error history clear command (address: 1000H).

For the error history clear, refer to the following:

- Error history clear command (📄 Page 199, Appendix 3 (18))

(b) Device number

The device number of this input signal is as follows:

Signal name	Main D/A converter module	Extension D/A converter module
Error flag	RXA	

(4) Remote READY

This signal is used as an interlock condition when the master station reads/writes data to/from the remote register or remote buffer memory areas of the D/A converter module.

Upon turning on the module power supply, remote READY (RXB) turns on.

As Error flag (RXA) turns on, Remote READY (RXB) turns off.

(a) Device number

The device number of this input signal is as follows:

Signal name	Main D/A converter module	Extension D/A converter module
Remote READY	RXB	

(5) Trigger output completed flag

- In trigger output mode, turning on Trigger output request (RY19, RY29) from off allows D/A conversion to be performed on all the channels where D/A conversion is enabled. Once the D/A conversion is complete in all the channels where D/A conversion is enabled, Trigger output completed flag (RX19, RX29) turns from Output waiting (OFF) to Output completed (ON).
- While Trigger output completed flag (RX19, RX29) is in Output completed (ON), changing Trigger output completed clear request (RY1A, RY2A) from No request (OFF) to Clear request (ON) results in Trigger output completed flag (RX19, RX29) turning from Output completed (ON) to Output waiting (OFF). Check that Trigger output completed flag (RX19, RX29) turns to Output waiting (OFF), and then turn off Trigger output completed clear request (RY1A, RY2A) from on.
- While Trigger output completed flag (RX19, RX29) is in Output completed (ON), turning on Trigger output request (RY19, RY29) from off allows D/A conversion to be performed, updating the analog output value.
- Turning on and off Initial data setting request flag (RY9) results in Trigger output completed flag (RX19, RX29) turning off.

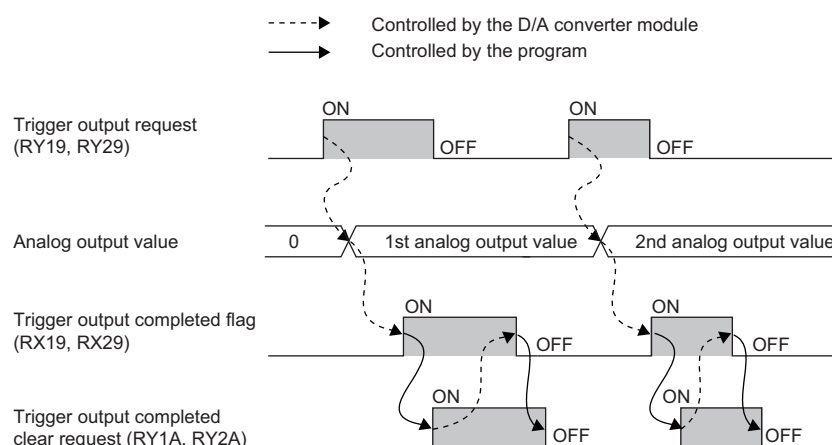

(a) Device number

The device numbers of this input signal are as follows:

Signal name	Main D/A converter module	Extension D/A converter module
Trigger output completed flag	RX19	RX29

(6) Alert output signal

This signal turns on if a digital value falls into any of the following conditions even in one channel, of all the channels where D/A conversion is enabled:

- Digital value > Alert output upper limit value
- Digital value < Alert output lower limit value

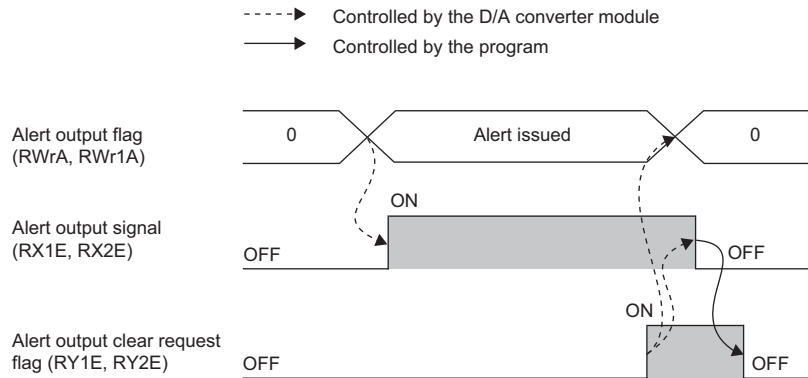

(a) How to turn off the alert output signal

Turn off the signal by either of the following methods:

- Turning on and off Alert output clear request flag (RY1E, RY2E)
- Turning on and off Initial data setting request flag (RY9)

An alarm code, if stored in Latest warning code (RWr1), is cleared.

(b) Device number

The device numbers of this input signal are as follows:

Signal name	Main D/A converter module	Extension D/A converter module
Alert output signal	RX1E	RX2E

(7) External power supply monitor status flag

This signal turns on when the external power supply monitoring function is being activated by External power supply monitor request flag (RY1F).

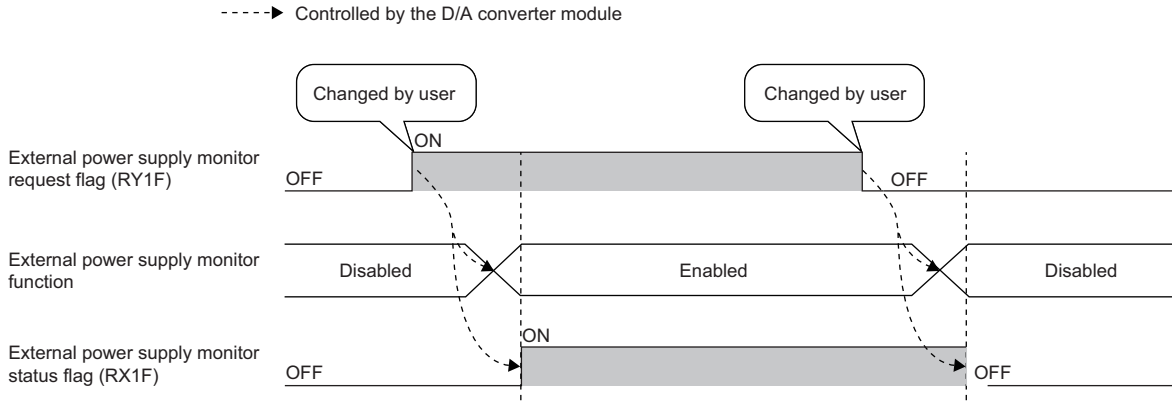

For the external power supply monitoring function, refer to the following:

- External power supply monitoring function (👉 Page 129, Section 8.16.1 (1))

(a) Device number

The device number of this input signal is as follows:

Signal name	Main D/A converter module	Extension D/A converter module
External power supply monitor status flag	RX1F	—

(8) External power supply READY flag

This signal indicates the state of the external power supply of the extension D/A converter module.

(a) Behavior when the external power supply of the extension D/A converter module is in an off state

External power supply READY flag (RX2F) remains off, and the RUN LED of the extension D/A converter module flashes.

D/A conversion processing of the extension D/A converter module is not performed.

(b) Behavior when the external power supply of the extension D/A converter module is turned on from off

Turning on the external power supply from off results in External power supply READY flag (RX2F) turning on and the RUN LED of the extension D/A converter module lighting up. D/A conversion processing starts for the conversion-enabled channels in the extension D/A converter module.

(c) Behavior when the external power supply of the extension D/A converter module is turned off from on

Turning off the external power supply of the extension D/A converter module from on results in External power supply READY flag (RX2F) turning off and the RUN LED of the extension D/A converter module flashing.

D/A conversion processing of the extension D/A converter module stops.

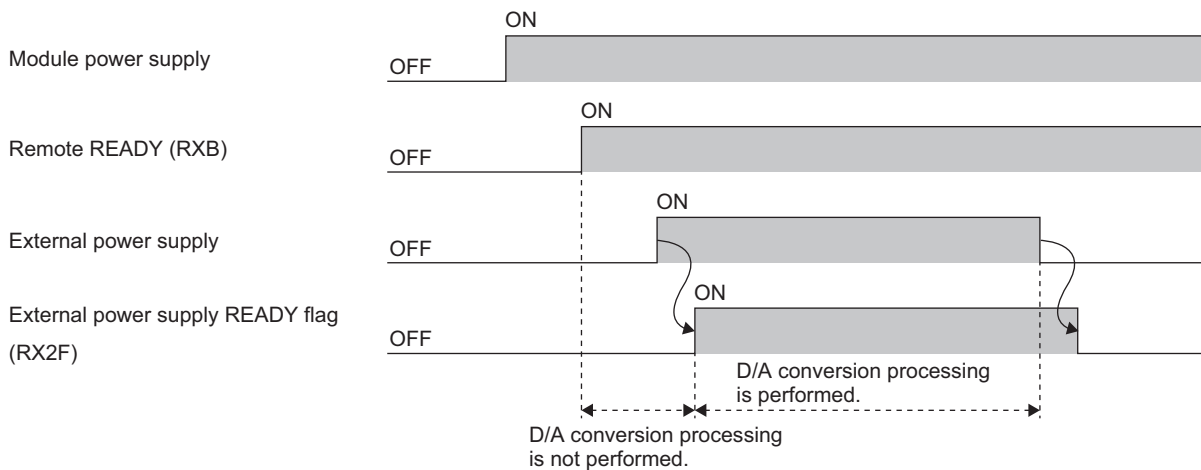

(d) Device number

The device number of this input signal is as follows:

Signal name	Main D/A converter module	Extension D/A converter module
External power supply READY flag	—	RX2F

Point

- D/A conversion processing of the main D/A converter module can be performed regardless of the on/off state of the external power supply of the extension D/A converter module.
- Use an external power supply that satisfies the specifications described in the performance specifications (Page 26, Section 3.2.2). If it does not meet the specifications, External power supply READY flag (RX2F) remains off.
- When the extension D/A converter module is used, use the signal as an interlock condition.

Appendix 1.2 Remote output signals

(1) Initial data setting request flag

Turn on Initial data setting request flag (RY9) after writing parameter data to the remote buffer memory. Upon completion of the change of operating conditions, Initial data setting completed flag (RX9) turns on.

For the timing "OFF→ON→OFF", refer to the following:

- Initial data setting completed flag (☞ Page 171, Appendix 1.1 (2))

(a) Device number

The device number of this output signal is as follows:

Signal name	Main D/A converter module	Extension D/A converter module
Initial data setting request flag	RY9	

(2) Error clear request flag

This signal is used to clear Error flag (RXA) and Latest error code (RWr0).

(a) When a moderate error occurs

Eliminating the cause of the error and turning on Error clear request flag (RYA) from off allows the error status to be cleared, resulting in Error flag (RXA) turning off.

Before Error flag (RXA) turns off, turning off Error clear request flag (RYA) from on does not allow Error flag (RXA) to turn off.

For the timing "OFF→ON→OFF", refer to the following:

- Error flag (☞ Page 172, Appendix 1.1 (3))

(b) When a major error occurs

Turning on and off Error clear request flag (RYA) does not allow Error flag (RXA) to turn off.

For the timing "OFF→ON→OFF", refer to the following:

- Error flag (☞ Page 172, Appendix 1.1 (3))

(c) Device number

The device number of this output signal is as follows:

Signal name	Main D/A converter module	Extension D/A converter module
Error clear request flag	RYA	

(3) CH□ Output enable/disable flag

Set whether to output the D/A conversion value or the offset value for each channel.

ON: D/A conversion value

OFF: Offset value

(a) D/A conversion period

Regardless of turning on CH□ Output enable/disable flag (RY10 to RY13, RY20 to RY23) from off, the conversion period is fixed.

(b) Device number

The device numbers of this output signal are as follows:

Signal name	Main D/A converter module				Extension D/A converter module			
	CH1	CH2	CH3	CH4	CH1	CH2	CH3	CH4
CH□ Output enable/disable flag	RY10	RY11	RY12	RY13	RY20	RY21	RY22	RY23

(4) Trigger output request

In trigger output mode, D/A conversion is performed at the time of turning on Trigger output request (RY19, RY29) from off.

For the timing "OFF→ON→OFF", refer to the following:

- Trigger output completed flag (☞ Page 173, Appendix 1.1 (5))

(a) Device number

The device numbers of this output signal are as follows:

Signal name	Main D/A converter module	Extension D/A converter module
Trigger output request	RY19	RY29

(5) Trigger output completed clear request

While Trigger output completed flag (RX19, RX29) is in an on state, turning on Trigger output completed clear request (RY1A, RY2A) from off allows Trigger output completed flag (RX19, RX29) to be cleared.

For the timing "OFF→ON→OFF", refer to the following:

- Trigger output completed flag (☞ Page 173, Appendix 1.1 (5))

(a) Device number

The device numbers of this output signal are as follows:

Signal name	Main D/A converter module	Extension D/A converter module
Trigger output completed clear request	RY1A	RY2A

(6) Alert output clear request flag

Turn on and off this signal to clear an alert output.

For the timing "OFF→ON→OFF", refer to the following:

- Alert output signal (☞ Page 174, Appendix 1.1 (6))

(a) Device number

The device numbers of this output signal are as follows:

Signal name	Main D/A converter module	Extension D/A converter module
Alert output clear request flag	RY1E	RY2E

(7) External power supply monitor request flag

Turn on this flag to activate the external power supply monitoring function.

For the timing "OFF→ON→OFF", refer to the following:

- External power supply monitor status flag (☞ Page 175, Appendix 1.1 (7))

(a) Device number

The device number of this output signal is as follows:

Signal name	Main D/A converter module	Extension D/A converter module
Alert output clear request flag	RY1F	—

Appendix 2 Details of Remote Registers

This section describes the details of the remote registers for a master/local module.

The described assignment of device numbers assumes that the remote registers of the main module are assigned to RWr0 to RWrF and RWw0 to RWwF.

(1) Latest error code

An error code is stored when a moderate error or major error occurs.

Turning on Error clear request flag (RYA) after eliminating the cause of the error clears the error code.

Errors that occurred in the past can be checked with Error history data□ (address: 0A00H to 0AEFH). For the error history, refer to the following:

- Error history data□ (☞ Page 198, Appendix 3 (17))

(a) Device number

The device number of this remote register is as follows:

Remote register name	Main D/A converter module	Extension D/A converter module
Latest error code	RWr0	

(2) Latest warning code

An error code is stored when a minor error occurs. An alarm code is stored when an alarm occurs.

After a minor error has occurred, eliminating the cause of the error and then waiting for five seconds results in Latest warning code (RWr1) being automatically cleared.

Errors or alarms that occurred in the past can be checked with Error history data□ (address: 0A00H to 0AEFH). For the error history, refer to the following:

- Error history data□ (☞ Page 198, Appendix 3 (17))

(a) Device number

The device number of this remote register is as follows:

Remote register name	Main D/A converter module	Extension D/A converter module
Latest warning code	RWr1	

(3) CH□ Set value check code

When the set digital value is out of the setting range, the check code is stored.

For details on the digital value range check function, refer to the following:

- Digital Value Range Check Function (Page 105, Section 8.11)

The following table lists the check codes.

Check code	Description
000FH	A digital value exceeding the setting range is written.
00F0H	A digital value less than the setting range is written.
00FFH	Digital values greater and less than the setting range are written. For example, the check code 00FFH is stored when a digital value less than the setting range is written after a digital value greater than the setting range is written and the check code is not reset.

The stored check code is not cleared even if the digital value falls within the setting range.

When Scaling enable/disable setting (address: 010EH, 020EH) is set to Enable (0), the scale-converted digital value is the target for the check code. However, when the scale-converted digital value is out of the setting range, a slight inaccuracy may be contained in the target digital value for the check code when the check code is stored due to an operational error in the scale conversion.

When a value is set for CH□ Shifting set value (RWw6 to RWw9, RWw16 to RWw19), the value with the shifting set value added is the target for the check code.

(a) Resetting set value check codes

The check codes can be reset in the following two procedures:

- Write the digital value within the setting range, and turn on and off Error clear request flag (RYA).
- Turn on and off Initial data setting request flag (RY9).

(b) Default value

The default value is Within the setting range (0000H).

(c) Device number

The device numbers of this remote register are as follows:

Remote register name	Main D/A converter module				Extension D/A converter module			
	CH1	CH2	CH3	CH4	CH1	CH2	CH3	CH4
CH□ Set value check code	RWr2	RWr3	RWr4	RWr5	RWr12	RWr13	RWr14	RWr15

(4) Alert output flag

Whether the upper limit value or the lower limit value causes the alert can be checked for each channel.

For details on the alert output function, refer to the following:

- Alert Output Function (Page 107, Section 8.12)

b15	b14	b13	b12	b11	b10	b9	b8	b7	b6	b5	b4	b3	b2	b1	b0
0	0	0	0	0	0	0	0	CH4 Lower limit value	CH4 Upper limit value	CH3 Lower limit value	CH3 Upper limit value	CH2 Lower limit value	CH2 Upper limit value	CH1 Lower limit value	CH1 Upper limit value

The values of b8 to b15 are fixed to 0.

0: Normal
1: Alert issued

(a) Alert output flag status

On any of the following conditions, Alert (1) is stored to Alert output flag corresponding to each channel.

- Digital value > Alert output upper limit value
- Digital value < Alert output lower limit value

Of the channels where D/A conversion is enabled and alert output is enabled, even one channel where an alert is detected results in Alert output signal (RX1E, RX2E) turning on.

(b) Clearing Alert output flag

Alert output flag (RWrA, RWr1A) is cleared by either of the following two methods.

- Turning on and off Alert output clear request flag (RY1E, RY2E)
- Turning on and off Initial data setting request flag (RY9)

(c) Default value

The default value is Normal (0) for all channels.

(d) Device number

The device numbers of this remote register are as follows:

Remote register name	Main D/A converter module	Extension D/A converter module
Alert output flag	RWrA	RWr1A

(5) CH□ Digital value

On this area, the digital value for D/A conversion is written, in signed 16-bit binary, from the CPU module.

Output range setting	When the scaling function is disabled		When the scaling function is enabled*1
	Setting range (Actual range)	Digital value when a value out of the setting range is written	Setting range
0: 4 to 20mA	-288 to 12287 (Actual range: 0 to 12000)	12288 or more: 12287 -289 or less: -288	-32768 to 32767 (Maximum actual range: -32000 to 32000)
1: 0 to 20mA			
2: 1 to 5V			
3: 0 to 5V			
4: -10 to 10V	-16384 to 16383 (Actual range: -16000 to 16000)	16384 or more: 16383 -16385 or less: -16384	
5: User range setting 1(-10 to 10V)*2	-12288 to 12287 (Actual range: -12000 to 12000)	12288 or more: 12287 -12289 or less: -12288	
6: User range setting 2(0 to 20mA)*2	-288 to 12287 (Actual range: 0 to 12000)	12288 or more: 12287 -289 or less: -288	

*1 The setting range and the actual range of when the scaling function is enabled depend on the settings in the scaling upper limit value and the scaling lower limit value.

*2 The extension D/A converter module does not support User range setting 1 and User range setting 2.

(a) When a value out of the setting range is written

D/A conversion is performed with the upper and lower limit value of the setting range. Simultaneously, the following status notifies that the setting is out of the range.

- The check code is stored in CH□ Set value check code (RWr2 to RWr5, RWr12 to RWr15). For details on check codes, refer to  Page 181, Appendix 2 (3).
- The error code (060□ or 160□) for an out-of-range digital value is stored in Latest warning code (RWr1).
- Warning flag (RX7) turns on.
- The ALM LED flashes.

(b) Default value

The default value is 0 for all channels.

(c) Device number

The device numbers of this remote register are as follows:

Remote register name	Main D/A converter module				Extension D/A converter module			
	CH1	CH2	CH3	CH4	CH1	CH2	CH3	CH4
CH□ Digital value	RWw2	RWw3	RWw4	RWw5	RWw12	RWw13	RWw14	RWw15

(6) CH□ Shifting set value

Set the shifting set value that is to be used for the shift function in signed 16-bit binary. The digital value with shift addition is D/A converted.

For details on the shift function, refer to the following:

- Shift Function (☞ Page 101, Section 8.10)

(a) Setting range

The setting range is -32768 to 32767.

(b) Enabling the setting

Once a value is set, the shifting set value is valid regardless of turning on and off Initial data setting request flag (RY9).

(c) Default value

The default value is 0 for all channels.

(d) Device number

The device numbers of this remote register are as follows:

Remote register name	Main D/A converter module				Extension D/A converter module			
	CH1	CH2	CH3	CH4	CH1	CH2	CH3	CH4
CH□ Shifting set value	RWw6	RWw7	RWw8	RWw9	RWw16	RWw17	RWw18	RWw19

Appendix 3 Details of Remote Buffer Memory

This section describes the details of remote buffer memory areas of the D/A converter module.

(1) Mode switch

Set the mode for all channels.

Mode	Setting value
Normal mode	0H
Trigger output mode	1H
Automatic judgment mode	9H

Setting a value other than the above results in the error code (0730H) being stored in Latest error code (RWr0), Error flag (RXA) turning on, and the ERR. LED lighting up, with Automatic judgment mode (9H) set up.

(a) Enabling the setting

1. Turn on and off Initial data setting request flag (RY9).
2. Check that "0920H" is stored in Latest warning code (RWr1).
3. Turn off and on the power supply.

(b) Default value

The default value is Automatic judgment mode (9H).

(c) Remote buffer memory address

The remote buffer memory address of this area is as follows:

Remote buffer memory name	Main D/A converter module	Extension D/A converter module
Mode switch	0000H	

(2) Trigger output signal assignment

Assign Trigger output request (RY19) of the main D/A converter module to Remote input (RX) of the extension input module using the external signal assignment function. Turning on the assigned Remote input (RX) from off allows D/A conversion to be performed through the trigger output function.

(a) Setting range

With the head of Remote input (RX) of the main D/A converter module as a starting point (0000H), set the number, which is counted from the head, of Remote input (RX) of the extension module.

Ex. When Trigger output request (RY19) is assigned to Remote input (RX) numbered 8H as counted from the head (0H) of the extension input module

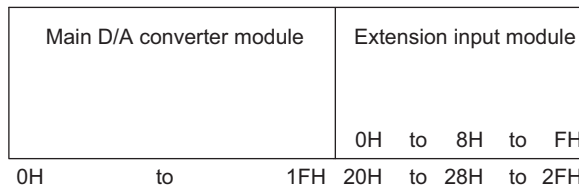

Remote input (RX) numbered 8H as counted from the head of the extension input module corresponds to Remote input (RX) numbered 28H as counted from the head of the main D/A converter module. Thus, set 28H for Trigger output signal assignment (address: 0002H).

(b) Enabling the setting

Turn on and off Initial data setting request flag (RY9) to enable the setting.

(c) Default value

The default value is No assignment (FFFFH).

(d) Remote buffer memory address

The remote buffer memory address of this area is as follows:

Remote buffer memory name	Main D/A converter module	Extension D/A converter module
Trigger output signal assignment	0002H	—

Point

- Setting a value out of the range results in the error code (0170H) being stored in Latest error code (RWr0), Error flag (RXA) turning on, and the ERR. LED lighting up, with the previously set operation.
- With Trigger output signal assignment (address: 0002H) set to Remote input (RX) of the extension input module, turning on Trigger output request (RY19) from off does not allow D/A conversion. Turn on Remote input (RX), which is set in Trigger output signal assignment (address: 0002H), from off.

(3) Alert output signal assignment

Assign Alert output signal (RX1E) of the main D/A converter module to Remote output (RY) of the extension output module using the external signal assignment function.

As an alert occurs, the assigned Remote output (RY) turns on.

(a) Setting range

With the head of Remote output (RY) of the main D/A converter module as a starting point (0000H), set the number, which is counted from the head, of Remote output (RY) of the extension module.

Ex. When Alert output signal (RX1E) is assigned to Remote output (RY) numbered 2H as counted from the head (0H) of the extension output module

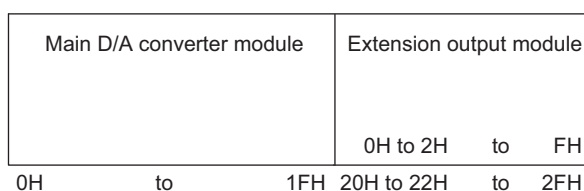

Remote output (RY) numbered 2H as counted from the head of the extension output module corresponds to Remote output (RY) numbered 22H as counted from the head of the main D/A converter module.

Thus, set 22H for Alert output signal assignment (address: 0004H).

(b) Enabling the setting

Turn on and off Initial data setting request flag (RY9) to enable the setting.

(c) Default value

The default value is No assignment (FFFFH).

(d) Remote buffer memory address

The remote buffer memory address of this area is as follows:

Remote buffer memory name	Main D/A converter module	Extension D/A converter module
Alert output signal assignment	0004H	—

Point

Setting a value out of the range results in the error code (0172H) being stored in Latest error code (RWr0), Error flag (RXA) turning on, and the ERR. LED lighting up, with the previously set operation.

(4) Error flag assignment

Error flag (RXA) is assigned to Remote output (RY) of the extension output module using the external signal assignment function. When a moderate error or major error occurs, the assigned Remote output (RY) turns on.

(a) Setting range

With the head of Remote output (RY) of the main D/A converter module as a starting point (0000H), set the device number for Remote output (RY) of the connected extension output module.

Ex. When Error flag (RXA) is assigned to Remote output (RY) numbered 4H as counted from the head (0H) of the extension output module

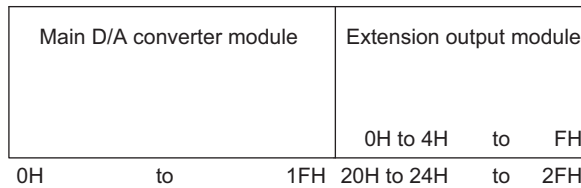

Remote output (RY) numbered 4H as counted from the head of the extension output module corresponds to Remote output (RY) numbered 24H as counted from the head of the main D/A converter module.

Thus, set 24H for Error flag assignment (address: 0005H).

(b) Enabling the setting

Turn on and off Initial data setting request flag (RY9) to enable the setting.

(c) Default value

The default value is No assignment (FFFFH).

(d) Remote buffer memory address

The remote buffer memory address of this area is as follows:

Remote buffer memory name	Main D/A converter module	Extension D/A converter module
Error flag assignment	0005H	—

Point

Setting a value out of the range results in the error code (0173H) being stored in Latest error code (RWr0), Error flag (RXA) turning on, and the ERR. LED lighting up, with the previously set operation.

(5) Warning flag assignment

Warning flag (RX7) is assigned to the remote output (RY) of the extension output module using the external signal assignment function. When a minor error occurs, the assigned Remote output (RY) turns on.

(a) Setting range

With the head of Remote output (RY) of the main D/A converter module as a starting point (0000H), set the device number for Remote output (RY) of the connected extension output module.

Ex. When Warning flag (RX7) is assigned to Remote output (RY) numbered 6H as counted from the head (0H) of the extension output module

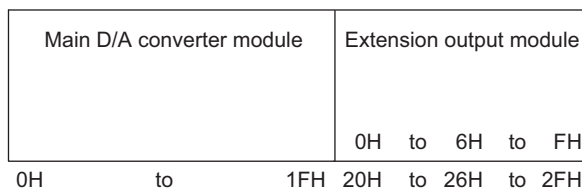

Remote output (RY) numbered 6H as counted from the head of the extension output module corresponds to Remote output (RY) numbered 26H as counted from the head of the main D/A converter module.

Thus, set 26H for Warning flag assignment (address: 0006H).

(b) Enabling the setting

Turn on and off Initial data setting request flag (RY9) to enable the setting.

(c) Default value

The default value is No assignment (FFFFH).

(d) Remote buffer memory address

The remote buffer memory address of this area is as follows:

Remote buffer memory name	Main D/A converter module	Extension D/A converter module
Warning status flag assignment	0006H	—

Point

Setting a value out of the range results in the error code (0174H) being stored in Latest error code (RWr0), Error flag (RXA) turning on, and the ERR. LED lighting up, with the previously set operation.

(6) Cyclic data update watch time setting

This signal is used to set the time to monitor the data update interval of the cyclic transmission (watch time). A cyclic transmission stop state that persists over the cyclic data update watch time is regarded as being in disconnection, where the output status of the extension output module becomes HOLD or CLEAR according to Digital output HOLD/CLEAR setting (address: 0011H) and Analog output HOLD/CLEAR setting (address: 0104H).

For Digital output HOLD/CLEAR setting (address: 0011H), refer to the following:

- Digital output HOLD/CLEAR setting (☞ Page 192, Appendix 3 (8))

For Analog output HOLD/CLEAR setting (address: 0104H, 0204H), refer to the following:

- Analog output HOLD/CLEAR setting (☞ Page 194, Appendix 3 (11))

(a) Setting range

Setting range is Not monitor (0) or 0.1 to 2 seconds (1 to 20). Set the value in increments of 100ms (1).

(b) Enabling the setting

Turn on and off Initial data setting request flag (RY9) to enable the setting.

(c) Default value

The default value is Not monitor (0).

(d) Remote buffer memory address

The remote buffer memory address of this area is as follows:

Remote buffer memory name	Main D/A converter module	Extension D/A converter module
Cyclic data update watch time setting	0007H	

Point

- Setting a value out of the range results in the error code (0930H) being stored in Latest error code (RWr0), Error flag (RXA) turning on, and the ERR. LED lighting up, with the I/O operation stopping.
- Synchronous communication mode ignores the set value, resulting in operation with Not monitor (0).

(7) Input response time setting

Set the input response time of the extension input module.

Input response time	Setting value
1.0ms	2H
1.5ms	3H
5ms	4H
10ms	5H
20ms	6H
70ms	7H

(a) Enabling the setting

Turn on and off Initial data setting request flag (RY9) to enable the setting.

(b) Default value

The default value is 10ms (5H).

(c) Remote buffer memory address

The remote buffer memory address of this area is as follows:

Remote buffer memory name	Main D/A converter module	Extension D/A converter module
Input response time setting	0010H	—

Point

- Setting data other than the above results in the error code (1F40H) being stored in Latest error code (RWr0), Error flag (RXA) turning on, and the ERR. LED lighting up.
- When no extension input module is connected, the setting of Input response time setting (address: 0010H) is ignored.

(8) Digital output HOLD/CLEAR setting

Set the output HOLD/CLEAR of the extension output module.

For the output HOLD/CLEAR setting function, refer to the following:

 CC-Link IE Field Network Remote I/O Module User's Manual

Digital output HOLD/CLEAR setting	Setting value
CLEAR	0H
HOLD	1H

(a) Enabling the setting

Turn on and off Initial data setting request flag (RY9) to enable the setting.

(b) Default value

The default value is CLEAR (0H).

(c) Remote buffer memory address

The remote buffer memory address of this area is as follows:

Remote buffer memory name	Main D/A converter module	Extension D/A converter module
Digital output HOLD/CLEAR setting	0011H	—

Point

- When no extension output module is connected, the setting of Digital output HOLD/CLEAR setting (address: 0011H) is ignored.
- Setting data other than the above results in operation with the set value of the lower 1 bit.

(9) D/A conversion enable/disable setting

Set whether to enable or disable D/A conversion for each channel.

b15	b14	b13	b12	b11	b10	b9	b8	b7	b6	b5	b4	b3	b2	b1	b0
0	0	0	0	0	0	0	0	0	0	0	0	CH4	CH3	CH2	CH1

The values of b4 to b15 are fixed to 0. 0: D/A conversion enabled
 1: D/A conversion disabled

(a) Enabling the setting

Turn on and off Initial data setting request flag (RY9) to enable the setting.

(b) Default value

The default value is D/A conversion disabled (1) for all channels.

(c) Remote buffer memory address

The remote buffer memory addresses of this area are as follows:

Remote buffer memory name	Main D/A converter module				Extension D/A converter module			
	CH1	CH2	CH3	CH4	CH1	CH2	CH3	CH4
D/A conversion enable/disable setting	0102H				0202H			

(10) Range setting

Set the output range for each channel.

b15 to b12	b11 to b8	b7 to b4	b3 to b0
CH4	CH3	CH2	CH1

Output range	Setting value	
	Main D/A converter module	Extension D/A converter module
4 to 20mA	0H	0H
0 to 20mA	1H	1H
1 to 5V	2H	2H
0 to 5V	3H	3H
-10 to 10V	4H	4H
User range setting 1 (-10 to 10V)	5H	—
User range setting 2 (0 to 20mA)	6H	—

The range is not changed if D/A conversion enable/disable setting (address: 0102H, 0202H) is set to D/A conversion disabled. To change the range, set D/A conversion enable/disable setting (address: 0102H, 0202H) to D/A conversion enabled and turn on and off Initial data setting request flag (RY9).

(a) Enabling the setting

Turn on and off Initial data setting request flag (RY9) to enable the setting.

(b) Default value

The default value is 4 to 20mA (0H).

(c) Remote buffer memory address

The remote buffer memory addresses of this area are as follows:

Remote buffer memory name	Main D/A converter module				Extension D/A converter module			
	CH1	CH2	CH3	CH4	CH1	CH2	CH3	CH4
Range setting	0103H				0203H			

Point

Setting data other than the above results in the error code (010□H or 110□H) being stored in Latest error code (RW0), Error flag (RXA) turning on, and the ERR. LED lighting up.

(11) Analog output HOLD/CLEAR setting

For each channel, set whether to hold or clear the analog output value when the CPU module was in the RUN status, in the event of the STOP status or an error.

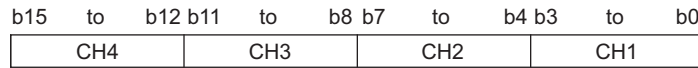

Analog output HOLD/CLEAR setting	Setting value
CLEAR	0H
HOLD	1H to FH (a number other than 0)

(a) Enabling the setting

Turn on and off Initial data setting request flag (RY9) to enable the setting.

(b) Default value

The default value is CLEAR (0H).

(c) Remote buffer memory address

The remote buffer memory addresses of this area are as follows:

Remote buffer memory name	Main D/A converter module				Extension D/A converter module			
	CH1	CH2	CH3	CH4	CH1	CH2	CH3	CH4
Analog output HOLD/CLEAR setting	0104H				0204H			

(12) Alert output setting

Set whether to enable or disable alert output for each channel.

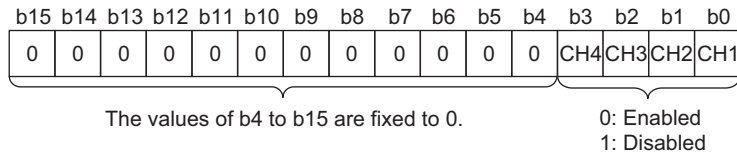

(a) Enabling the setting

Turn on and off Initial data setting request flag (RY9) to enable the setting.

(b) Default value

The default value is Disabled (1) for all channels.

(c) Remote buffer memory address

The remote buffer memory addresses of this area are as follows:

Remote buffer memory name	Main D/A converter module				Extension D/A converter module			
	CH1	CH2	CH3	CH4	CH1	CH2	CH3	CH4
Alert output setting	0105H				0205H			

(13)CH□ Alert output upper limit value, CH□ Alert output lower limit value

Set the upper and lower limit values of the alert output range.

For details on the alert output function, refer to the following:

- Alert Output Function (☞ Page 107, Section 8.12)

(a) Setting range

- Setting range: -32768 to 32767

(b) Enabling the setting

Turn on and off Initial data setting request flag (RY9) to enable the setting.

(c) Default value

The default value is 0 for all channels.

(d) Remote buffer memory address

The remote buffer memory addresses of this area are as follows:

Remote buffer memory name	Main D/A converter module				Extension D/A converter module			
	CH1	CH2	CH3	CH4	CH1	CH2	CH3	CH4
CH□ Alert output upper limit value	0106H	0108H	010AH	010CH	0206H	0208H	020AH	020CH
CH□ Alert output lower limit value	0107H	0109H	010BH	010DH	0207H	0209H	020BH	020DH

Point

- The settings must satisfy the condition: Alert output upper limit value > Alert output lower limit value. A channel that does not satisfy the condition causes an error with the error code (062□H or 162□H) being stored in Latest error code (RWr0), Error flag (RXA) turning on, and the ERR. LED lighting up.
- By default, 0 is set and so change the setting value when using the alert output function.
- When the scaling function or shift function is used, the digital value that reflects the operation of each function is the target for alert. The set digital value should allow for the operation results of each function.
- If Alert output setting (address: 0105H, 0205H) is set to Disabled (1), the settings of CH□ Alert output upper limit value and CH□ Alert output lower limit value are ignored.

(14) Scaling enable/disable setting

Set whether to enable or disable scaling for each channel.

For details on the scaling function, refer to the following:

Scaling Function ( Page 96, Section 8.9)

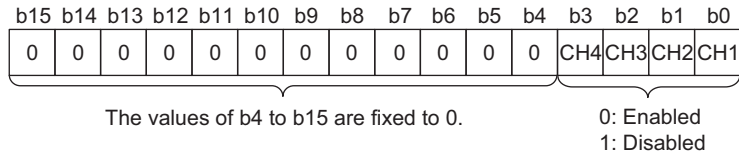

(a) Enabling the setting

Turn on and off Initial data setting request flag (RY9) to enable the setting.

(b) Default value

The default value is Disabled (1) for all channels.

(c) Remote buffer memory address

The remote buffer memory addresses of this area are as follows:

Remote buffer memory name	Main D/A converter module	Extension D/A converter module
Scaling enable/disable setting	010EH	020EH

(15) CH□ Scaling lower limit value, CH□ Scaling upper limit value

Set the range of scale conversion for each channel.

For details on the scaling function, refer to the following:

- Scaling Function (📖 Page 96, Section 8.9)

(a) Setting range

- Setting range: -32000 to 32000

(b) Enabling the setting

Turn on and off Initial data setting request flag (RY9) to enable the setting.

(c) Default value

The default value is 0 for all channels.

(d) Remote buffer memory address

The remote buffer memory addresses of this area are as follows:

Remote buffer memory name	Main D/A converter module				Extension D/A converter module			
	CH1	CH2	CH3	CH4	CH1	CH2	CH3	CH4
CH□ Scaling lower limit value	010FH	0111H	0113H	0115H	020FH	0211H	0213H	0215H
CH□ Scaling upper limit value	0110H	0112H	0114H	0116H	0210H	0212H	0214H	0216H

Point

- A channel where a value out of the range above is set causes an error with the error code (090□H or 190□H) being stored in Latest error code (RWr0), Error flag (RXA) turning on, and the ERR. LED lighting up.
- By default, 0 is set and so change the setting value when using the scaling function.
- The settings must satisfy the condition: Scaling upper limit value > Scaling lower limit value. A channel that does not satisfy the condition causes an error with the error code (091□H or 191□H) being stored in Latest error code (RWr0), Error flag (RXA) turning on, and the ERR. LED lighting up.
- If Scaling enable/disable setting (address: 010EH, 020EH) is set to Disabled (1), the settings of CH□ Scaling lower limit value and CH□ Scaling upper limit value are ignored.

(16) Extension module identification code

The identification code of a connected extension module is stored.

If the extension D/A converter module is connected, 2211H is stored.

For the identification codes of extension modules other than the extension D/A converter module, refer to the following:

📖 Manual including the description of the extension module used

(a) Remote buffer memory address

The remote buffer memory address of this area is as follows:

Remote buffer memory name	Main D/A converter module	Extension D/A converter module
Extension module identification code	—	0700H

(17) Error history data □

Up to 15 errors occurred in the module are stored.

The following shows the contents stored in Error history 1 (address: 0A00H to 0A0FH).

	b15	to	b8	b7	to	b0
0A00H	Error code					
0A01H	Number of chronological order					
0A02H	First two digits of year			Last two digits of year		
0A03H	Month			Day		
0A04H	Hour			Minute		
0A05H	Second			00H (fixed)		
0A06H	CH1 Digital value					
0A07H	CH2 Digital value					
0A08H	CH3 Digital value					
0A09H	CH4 Digital value					
0A0AH	System area					
to						
0A0FH						

Item	Contents	Storage example ^{*1}
Error code	The error code of the error that occurred is stored.	—
Order of generation	The order of error occurrence is stored. (A value in the range of 0 to 65535 is stored.)	0001H
First two digits of the year/Last two digits of the year ^{*2}	The items on the left are stored in BCD code.	2014H
Month/Date ^{*2}		1101H
Hour/Minute ^{*2}		1330H
Second/00H (Fixed) ^{*2}		5000H
CH1 Digital value	The value of CH□ Digital value (RWw2 to RWw5, RWw12 to RWw15) when an error occurs is stored.	—
CH2 Digital value		
CH3 Digital value		
CH4 Digital value		

*1 This example assumes that a second error has occurred at 13:30:50 on November 1, 2014.

*2 The clock information of the error that occurred is based on the clock information acquired from the CPU module of the master station.
When an error has occurred before the clock information is acquired from the CPU module, the error time is not recorded.

Error history 2 to Error history 15 (address: 0A10H to 0AEFH) are stored in the same format as that of Error history 1 (address: 0A00H to 0A0FH).

For the error codes, refer to the following:

- Error Code List (☞ Page 154, Section 11.2)

(a) Storage order

The latest error is stored in Error history 1 (address: 0A00H to 0A0FH).

Errors that occurred in the past are stored in Error history 2 to Error history 15 (address: 0A10H to 0AEFH) in reverse chronological order.

If 16 or more errors occur, errors are deleted from the oldest.

(b) Remote buffer memory address

The remote buffer memory addresses of this area are as follows:

Remote buffer memory name	Main D/A converter module	Extension D/A converter module
Error history data	0A00H to 0A0FH	

(18) Error history clear command

This command is used to clear the error history stored in the nonvolatile memory

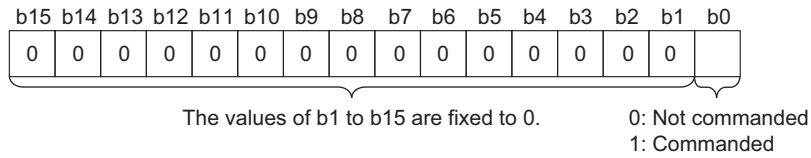

(a) Behavior of error history clear

Setting Error history clear command (address: 1000H) to Commanded (1) allows the error history to be cleared.

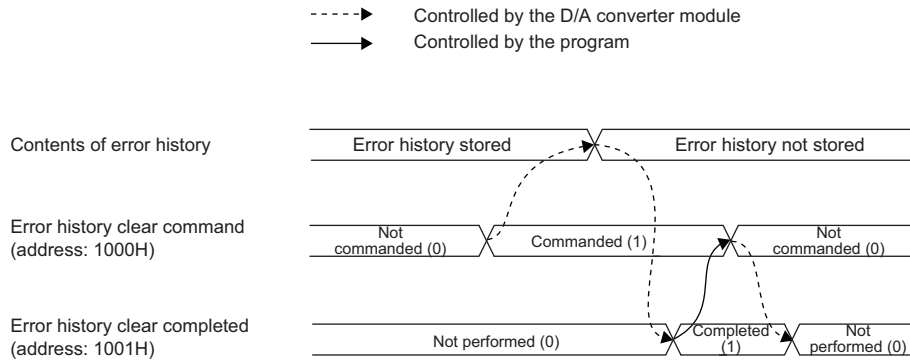

(b) Default value

The default value is Not commanded (0).

(c) Remote buffer memory address

The remote buffer memory address of this area is as follows:

Remote buffer memory name	Main D/A converter module	Extension D/A converter module
Error history clear command	1000H	—

(19) Error history clear completed

This remote buffer memory shows the error history clear completed status stored in the nonvolatile memory.

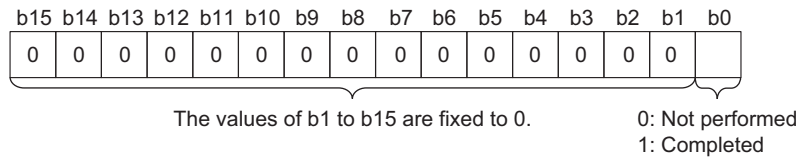

(a) Behavior of error history clear

Upon completion of the error history clear, Error history clear completed (address: 1001H) turns to Completed (1).

For the timing "Not performed (0)→Completed (1)→Not performed (0)", refer to the following:

- Error history clear command (📄 Page 199, Appendix 3 (18))

(b) Default value

The default value is Not performed (0).

(c) Remote buffer memory address

The remote buffer memory address of this area is as follows:

Remote buffer memory name	Main D/A converter module	Extension D/A converter module
Error history clear completed	1001H	—

(20)Parameter area initialization command

This command is used to set parameters in remote buffer memory areas and non-volatile memory to a default value.

In the event of a non-volatile memory data error (parameter) (error code: 0130H), using this command makes it possible to recover the module.

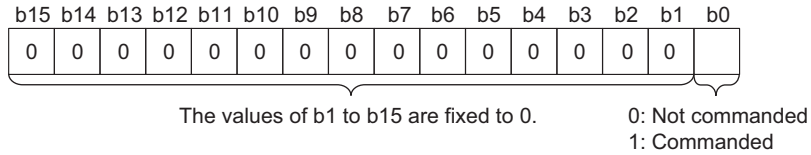

(a) Behavior of parameter area initialization

Setting Parameter area initialization command (address:1002H) to Commanded (1) sets the parameters in the non-volatile memory back to default values.

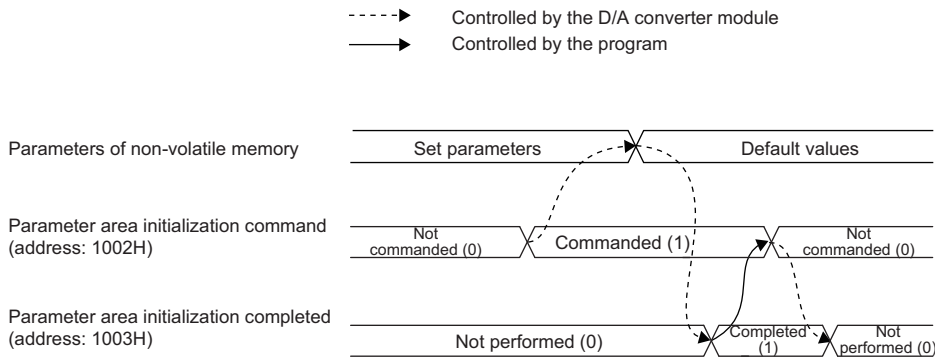

(b) Default value

The default value is Not commanded (0).

(c) Remote buffer memory address

The remote buffer memory address of this area is as follows:

Remote buffer memory name	Main D/A converter module	Extension D/A converter module
Parameter area initialization command	1002H	—

Point

An execution of Parameter area initialization command (address: 1002H) does not clear the following remote input signals and remote registers:

- Warning flag (RX7)
- Error flag (RXA)
- Alert output signal (RX1E, RX2E)

In addition, Remote READY (RXB) does not turn on.

After the execution of Parameter area initialization command (address: 1002H), turning off and on the module power supply enables the module to operate normally.

(21)Parameter area initialization completed

This memory shows whether the parameters stored in the non-volatile memory is cleared or not.

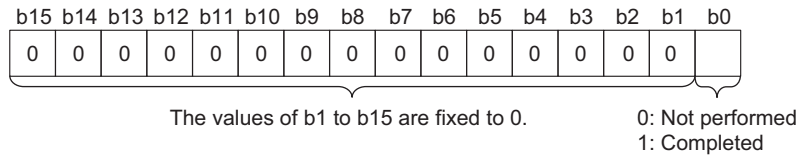

(a) Behavior of parameter area initialization

Upon the completion of setting the parameters stored in the non-volatile memory back to their default values, Parameter area initialization completed (address: 1003H) turns to Completed (1). For the timing "Not performed (0)→Completed (1)→Not performed (0)", refer to the following:

- Parameter area initialization command (↩ Page 201, Appendix 3 (20))

(b) Default value

The default value is Not performed (0).

(c) Remote buffer memory address

The remote buffer memory address of this area is as follows:

Remote buffer memory name	Main D/A converter module	Extension D/A converter module
Parameter area initialization completion	1003H	—

(22)Module operation information initialization command

This command is used to clear the module operation information stored in the non-volatile memory. Initialization of the module operation information is permitted provided that a non-volatile memory data error (module operation information) (error code: 0110H) occurs.

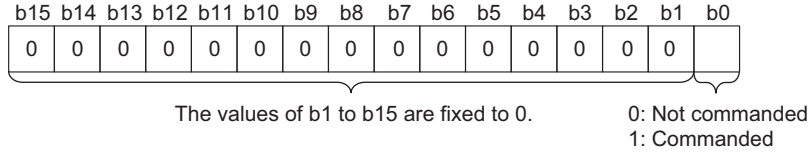

(a) Behavior of module operation information initialization

Setting Module operation information initialization command (address: 1004H) to Commanded (1) allows the module operation information to be initialized.

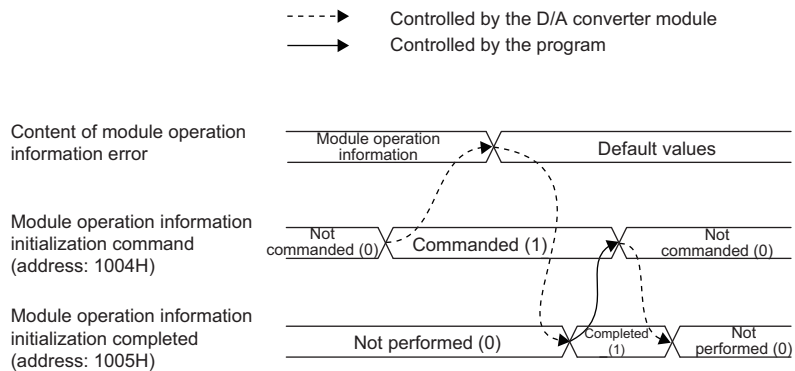

(b) Default value

The default value is Not commanded (0).

(c) Remote buffer memory address

The remote buffer memory address of this area is as follows:

Remote buffer memory name	Main D/A converter module	Extension D/A converter module
Module operation information initialization command	1004H	—

(23) Module operation information initialization completed

This memory area shows whether the module operation information stored in the non-volatile memory is initialized or not.

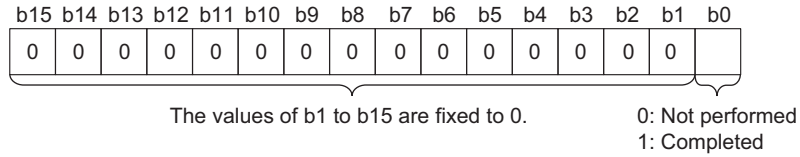

(a) Behavior of module operation information initialization

Upon completion of the initialization of module operation information, Module operation information initialization completed (address: 1005H) turns to Completed (1). For the timing "Not performed (0) → Completed (1) → Not performed (0)", refer to the following:

- Module operation information initialization command (Page 203, Appendix 3 (22))

(b) Default value

The default value is Not performed (0).

(c) Remote buffer memory address

The remote buffer memory address of this area is as follows:

Remote buffer memory name	Main D/A converter module	Extension D/A converter module
Module operation information initialization completed	1005H	—

Appendix 4 I/O Conversion Characteristics of D/A Conversion

The I/O conversion characteristics of D/A conversion are expressed by the slope of the straight line connecting the offset value and the gain value, both of which are used when a digital value written from the CPU module is converted to the corresponding analog output value (voltage or current output).

(1) Offset value

An analog output value (voltage or current) corresponding to the digital value 0 under the condition that the scaling function and the shift function are not used.

(2) Gain value

An analog output value (voltage or current) corresponding to the following digital value under the condition that the scaling function and the shift function are not used.

- 12000 (When the output range is set to 0 to 5V, 1 to 5V, 0 to 20mA, 4 to 20mA, user range setting 1, or user range setting 2)
- 16000 (When the output range is set to -10 to 10V)

(3) Voltage output characteristics

The following graph shows the voltage output characteristics.

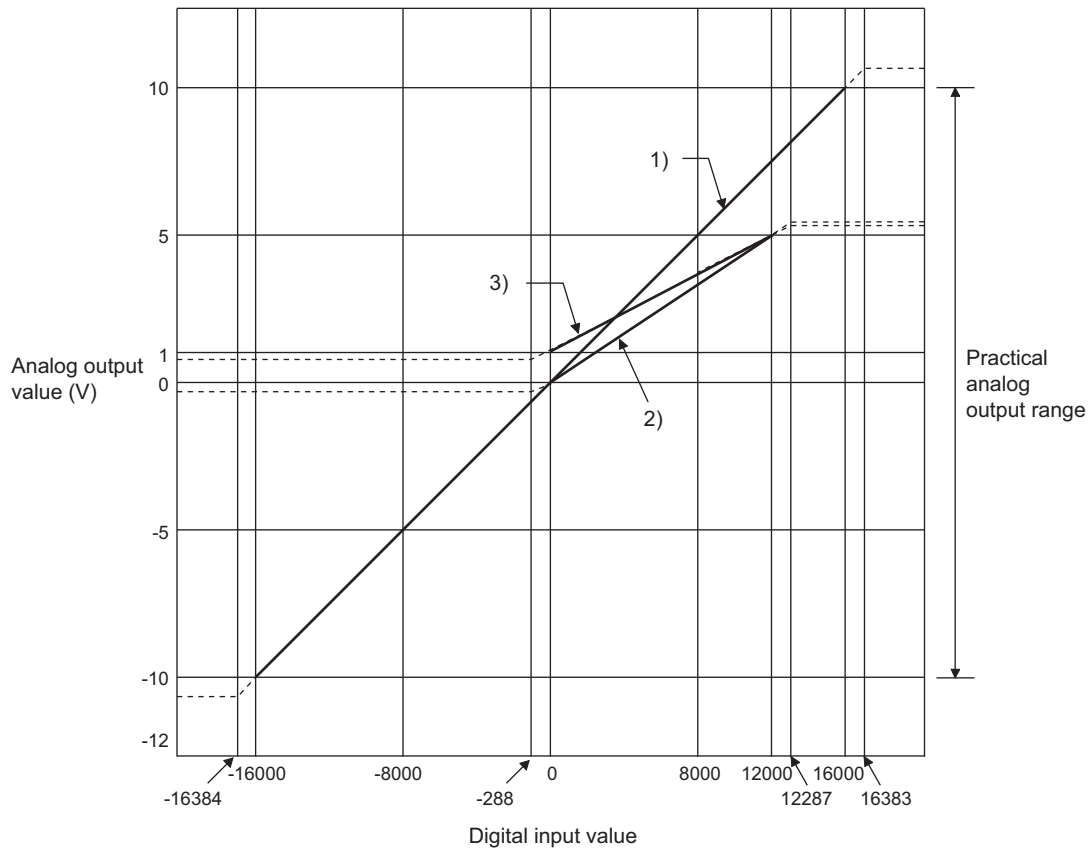

No.	Output range setting	Offset value	Gain value	Digital value	Maximum resolution
1)	-10 to 10V	0V	10V	-16000 to 16000	0.625mV
2)	0 to 5V	0V	5V	0 to 12000	0.416mV
3)	1 to 5V	1V	5V		0.333mV
—	User range setting 1*2 (-10 to 10V)	*1	*1	-12000 to 12000	0.333mV

*1 Set the offset value and gain value in the user range setting within the range satisfying the following two conditions:

- Setting range: -10 to 10V
- $((\text{Gain value}) - (\text{Offset value})) \geq 4.0\text{V}$

*2 The extension D/A converter modules does not support User range setting 1.

Point

Use the value within the practical digital input range and practical analog output range. If a value is out of the range, the maximum resolution and accuracy may not fall within the range of performance specifications. (Do not use the value in the dotted line region in the above graph.)

(4) Current output characteristics

The following graph shows the current output characteristics.

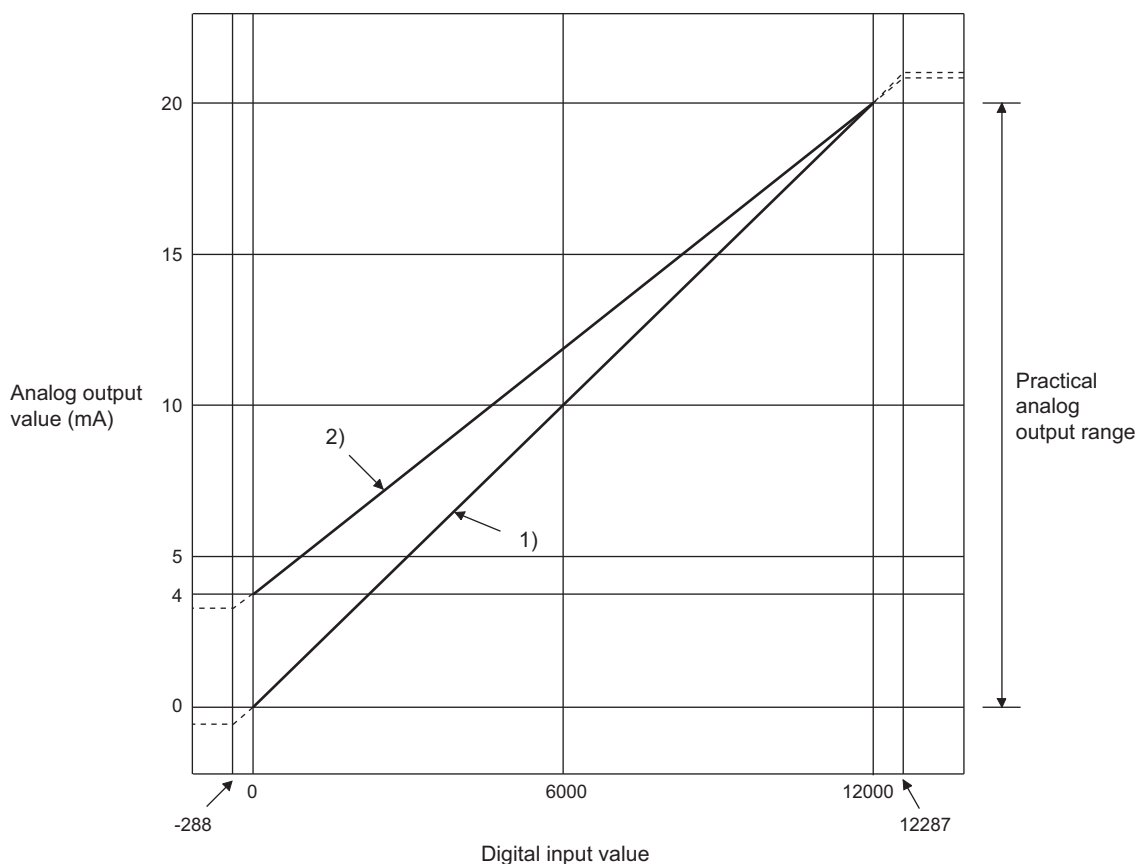

No.	Output range setting	Offset value	Gain value	Digital value	Maximum resolution
1)	4 to 20mA	4mA	20mA	0 to 12000	1.66 μ A
2)	0 to 20mA	0mA	20mA		1.33 μ A
—	User range setting 2 ²² (0 to 20mA)	*1	*1		0.95 μ A

*1 Set the offset value and gain value in the user range setting within the range satisfying the following two conditions:

- Setting range: 0 to 20mA
- ((Gain value) - (Offset value)) \geq 11.4mA

*2 The extension D/A converter modules does not support User range setting 2.

Point

Use the value within the practical digital input range and practical analog output range. If a value is out of the range, the maximum resolution and accuracy may not fall within the range of performance specifications. (Do not use the value in the dotted line region in the above graph.)

Appendix 5 Accuracy of D/A Conversion

Accuracy of D/A conversion is the accuracy for the maximum value of analog output value.

An output characteristic change caused by changing the offset/gain setting and the output range does not sacrifice the accuracy, which is maintained within the described range of the performance specifications.

The following graph shows the fluctuation range of accuracy with the range of 0 to 5V selected.

The accuracy of analog output is $\pm 0.2\%$ ($\pm 10\text{mV}$) at an ambient temperature of $25\pm 5^\circ\text{C}$; $\pm 0.3\%$ ($\pm 15\text{mV}$) at an ambient temperature of 0 to 55°C (except for the conditions under noise influence).

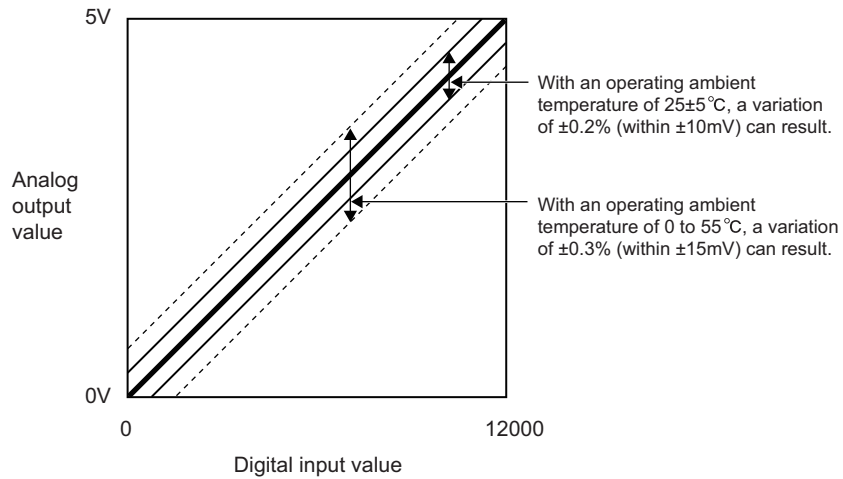

Appendix 6 Processing Time of CC-Link IE Field Network

A

The processing time of CC-Link IE Field Network is the time taken for the D/A converter module to perform D/A conversion on a digital value written with the CPU module of the master station, and output the actual analog output value.

The processing time of CC-Link IE Field Network depends on the following processing time:

- Sequence scan time of the master station
- Link scan time
- Processing time of the remote device station: conversion period (📖 Page 89, Section 8.5)

For details on the processing time of CC-Link IE Field Network, refer to the following:

📖 User's manual for the master/local module used

Appendix 7 EMC and Low Voltage Directives

Compliance to the EMC Directive, which is one of the EU Directives, has been a legal obligation for the products sold in European countries since 1996 as well as the Low Voltage Directive since 1997.

Manufacturers who recognize their products are compliant to the EMC and Low Voltage Directives are required to attach a "CE mark" on their products.

(1) Sales representative in EU member states

Authorized representative in EU member states is shown below.

Name: Mitsubishi Electric Europe BV

Address: Gothaer Strasse 8, 40880 Ratingen, Germany

Appendix 7.1 Measures to comply with the EMC Directive

The EMC Directive specifies that "products placed on the market must be so constructed that they do not cause excessive electromagnetic interference (emissions) and are not unduly affected by electromagnetic interference (immunity)".

This section summarizes the precautions on compliance with the EMC Directive of the machinery constructed with the module.

These precautions are based on the requirements and the standards of the regulation, however, it does not guarantee that the entire machinery constructed according to the descriptions will comply with abovementioned directives.

The method and judgement for complying with the EMC Directive must be determined by the person who constructs the entire machinery.

(1) EMC Directive related standards

(a) Emission requirements

Specification	Test item	Test details	Standard value
EN61131-2: 2007	CISPR16-2-3 Radiated emission* ²	Radio waves from the product are measured.	<ul style="list-style-type: none"> • 30M to 230MHz QP: 40dBμV/m (measured over 10m)^{*1} • 230M to 1000MHz QP: 47dBμV/m (measured over 10m)
	CISPR16-2-1, CISPR16-1-2 Conducted emission* ²	Noise from the product to the power line is measured.	<ul style="list-style-type: none"> • 150k-500kHz QP: 79dB, Mean: 66dB^{*1} • 500k-30MHz QP: 73dB, Mean: 60dB

*1 QP (Quasi-peak): quasi-peak value, Mean: mean value

*2 The module is an open type device (a device designed to be housed in other equipment) and must be installed inside a conductive control panel. The tests were conducted with the programmable controller installed in a control panel.

(b) Immunity requirements

Specification	Test item	Test details	Standard value
EN61131-2: 2007	EN61000-4-2 Electrostatic discharge immunity ^{*1}	Immunity test in which electrostatic is applied to the cabinet of the equipment.	<ul style="list-style-type: none"> • 8kV Air discharge • 4kV Contact discharge
	EN61000-4-3 Radiated, radio-frequency, electromagnetic field immunity ^{*1}	Immunity test in which electric fields are irradiated to the product.	<ul style="list-style-type: none"> • 80% AM modulation@1kHz • 80M-1000MHz: 10V/m • 1.4G-2.0GHz: 3V/m • 2.0G-2.7GHz: 1V/m
	EN61000-4-4 Electrical fast transient/burst immunity ^{*1}	Immunity test in which burst noise is applied to the power line and signal line.	<ul style="list-style-type: none"> • AC/DC main power, I/O power, AC I/O (unshielded): 2kV • DC I/O, analog, communication: 1kV
	EN61000-4-5 Surge immunity ^{*1}	Immunity test in which lightning surge is applied to the power line and signal line.	<ul style="list-style-type: none"> • AC power line, AC I/O power, AC I/O (unshielded): 2kV CM, 1kV DM • DC power line, DC I/O power: 0.5kV CM, DM • DC I/O, AC I/O (shielded), analog^{*2}, communication: 1kV CM
	EN61000-4-6 Immunity to conducted disturbances, induced by radio-frequency fields ^{*1}	Immunity test in which high frequency noise is applied to the power line and signal line	0.15M-80MHz, 80% AM modulation @1kHz, 10Vrms
	EN61000-4-8 Power-frequency magnetic field immunity ^{*1}	Immunity test in which the product is installed in inductive magnetic field	50Hz/60Hz, 30A/m
	EN61000-4-11 Voltage dips and interruption immunity ^{*1}	Immunity test in which power supply voltage is momentarily interrupted	<ul style="list-style-type: none"> • Apply at 0%, 0.5 cycles and zero-cross point • 0%, 250/300 cycles (50/60Hz) • 40%, 10/12 cycles (50/60Hz) • 70%, 25/30 cycles (50/60Hz)

*1 The module is an open type device (a device designed to be housed in other equipment) and must be installed inside a conductive control panel. The tests were conducted with the module installed in a control panel.

*2 The accuracy of an analog-digital converter module can indicate momentary fluctuation within $\pm 10\%$.

(2) Installation in a control panel

The module is open type devices and must be installed inside a control panel.

This ensures safety as well as effective shielding of programmable controller-generated electromagnetic noise.

(a) Control panel

- Use a conductive control panel.
- When securing the top or bottom plate using bolts, cover the grounding part on the control panel so that the part will not be painted.
- To ensure electrical contact between the inner plate and control panel, take measures such as covering the bolts so that conductivity can be ensured in the largest possible area.
- Ground the control panel with a thick ground cable so that low impedance can be ensured even at high frequencies.
- Holes in the control panel must be 10cm diameter or less. If the holes are larger than 10cm, radio wave may be emitted. In addition, because radio waves leak through a clearance between the control panel and its door, reduce the clearance as much as possible. The leakage of radio waves can be suppressed by the direct application of an EMI gasket on the paint surface.
- Our tests have been carried out on a control panel having the attenuation characteristics of 37dB (max.) and 30dB (mean) (measured by 3m method, 30 to 300MHz).

(b) Wiring of power cables and ground cables

- Near the power supply part, provide a ground point to the control panel. Ground the FG terminal with the thickest and shortest possible ground cable (30cm or shorter).

(3) Cables

Use shielded cables for the cables which are connected to the module and run out from the control panel. If a shielded cable is not used or not grounded correctly, the noise immunity will not meet the specified value.

(a) Cables for the CC-Link IE Field Network

The precautions for using CC-Link IE Field Network cables are as follows:

- CC-Link IE Field Network cables are made up of shielded wires. Strip a part of the jacket as shown below and ground the exposed shield in the largest possible area.

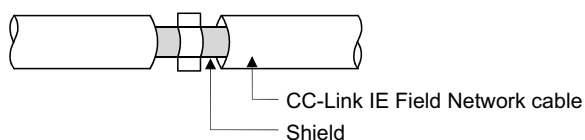

(b) Grounding the cable clamp

Use shielded cables for external wiring and ground the shields of the external wiring cables to the control panel with the AD75CK-type cable clamp (Mitsubishi). (Ground the shield section 20 to 30cm away from the module.)

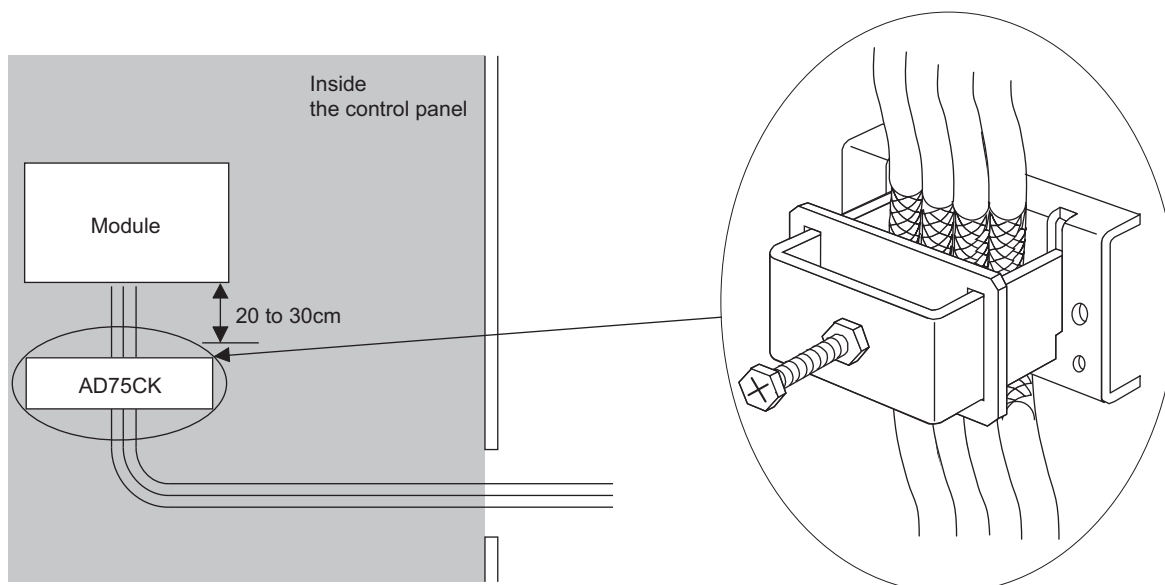

For details on the AD75CK, refer to the following:

📖 AD75CK-type Cable Clamping Instruction Manual

(c) Analog I/O signal line

Use a signal line of 30m or shorter when connecting it to the analog I/O terminals of the module.

(4) External power supply

- Use a CE-marked product for an external power supply and always ground the FG terminal. (External power supply used for the tests conducted by Mitsubishi: TDK-Lambda DLP-120-24-1, IDEC PS5R-SF24, PS5R-F24)
- Use a power cable of 10m or shorter when connecting it to the module power supply terminal.

(5) Others

(a) Ferrite core

A ferrite core has the effect of reducing radiated noise in the 30MHz to 100MHz band.

It is recommended to attach ferrite cores if shielded cables coming out of the control panel do not provide sufficient shielding effects.

Note that the ferrite cores must be attached at the position closest to the cable hole inside the control panel. If attached at an improper position, the ferrite core will not produce any effect.

For the FG terminal on a main module that is connected to the external power supply, the external power supply of an extension module, and CC-Link IE Field Network cables, attach a ferrite core 4cm away from the module.

(Ferrite core used for the tests conducted by Mitsubishi: NEC TOKIN ESD-SR-250, TDK ZCAT3035-1330)

Example

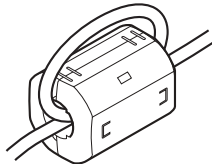

(b) Noise filter (power supply line filter)

A noise filter is a component which has an effect on conducted noise. Attaching the filter can suppress more noise. (The noise filter has the effect of reducing conducted noise of 10MHz or less.)

Connect a noise filter to the external power supply of a main module and the external power supply of an extension module. Use a noise filter with the damping characteristics equivalent to those of MA1206 (manufactured by TDK-Lambda Corporation). Note that a noise filter is not required if the module is used in Zone A defined in EN61131-2.

The precautions for attaching a noise filter are described below.

- Do not bundle the cables on the input side and output side of the noise filter. If bundled, the output side noise will be induced into the input side cables from which the noise was filtered.

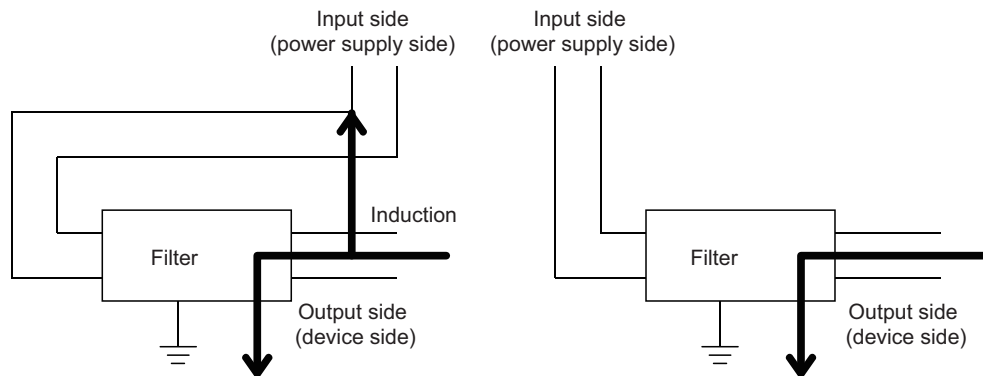

Noise is induced if an input line and an output line are bundled.

Arrange the wires with the input lines and the output lines separated.

- Ground the noise filter grounding terminal to the control panel with the shortest cable possible (approx. 10cm).

Appendix 7.2 **Requirements to compliance with the Low Voltage Directive**

The module operates at the rated voltage of 24VDC.

The Low Voltage Directive is not applied to the modules that operate at the rated voltage of less than 50VAC and 75VDC.

Appendix 8 How to Check Serial Number and Function Version

A

The serial number and the function version of the D/A converter module can be checked on the rating plate. The serial number can be also checked from production information in CC-Link IE Field Network diagnostics.

(1) Checking on the rating plate

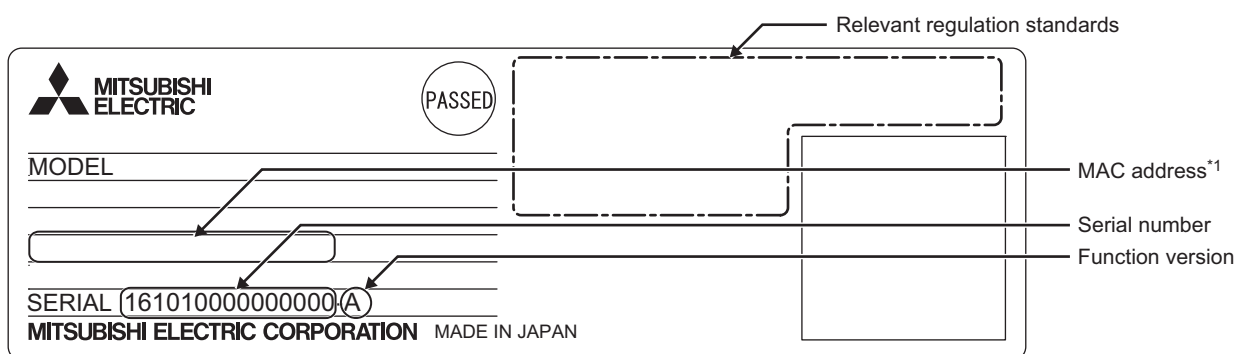

*1 The extension D/A converter module does not have a MAC address.

(2) Checking by using CC-Link IE Field Network diagnostics

1. Connect GX Works2 to the CPU module.
2. Start CC-Link IE Field Network diagnostics from the menu of GX Works2.
 - [Diagnostics] ⇒ [CC IE Field Diagnostics]
3. Right-click the slave station whose production information to be displayed, and select "Production Information".

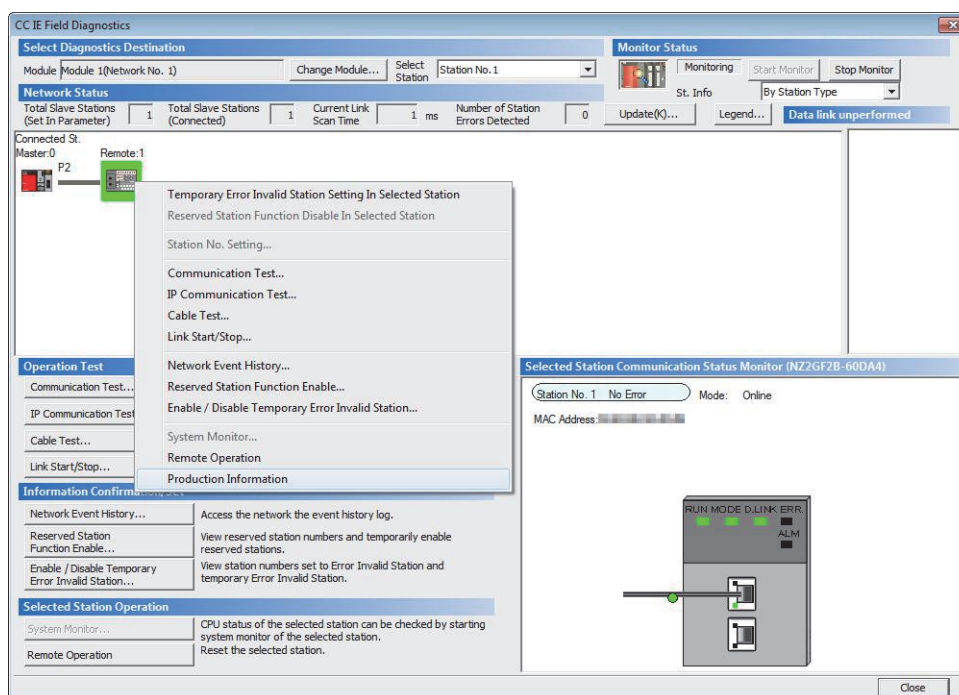

4. The production information appears.

The production information shows the serial number written on the rating plate.

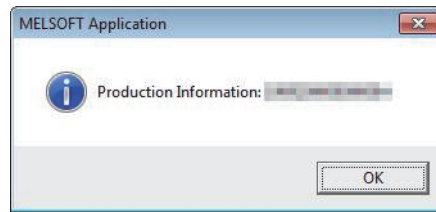

Appendix 9 Comparison with NZ2GF2B-60DA4

A

Appendix 9.1 Comparison of performance specifications

The following table shows the differences in the performance specifications between the NZ2GF2BN-60DA4 and the NZ2GF2B-60DA4.

Item	NZ2GF2BN-60DA4	NZ2GF2B-60DA4
External power supply	24VDC (20.4 to 28.8VDC) Inrush current: 39.0A, 1ms or lower Current consumption: 300mA	24VDC (20.4 to 28.8VDC) Inrush current: 30.1A, 1.5ms or lower Current consumption: 325mA
Weight	0.29kg	0.30kg

Appendix 9.2 Functional comparison

The following table shows the differences in the functions between the NZ2GF2BN-60DA4 and the NZ2GF2B-60DA4.

Item	NZ2GF2BN-60DA4	NZ2GF2B-60DA4
Support for extension modules	The following extension modules can be mounted: <ul style="list-style-type: none"> • Extension input module • Extension output module • Extension A/D converter module • Extension D/A converter module 	The following extension modules can be mounted: <ul style="list-style-type: none"> • Extension input module • Extension output module

Appendix 9.3 About replacement from NZ2GF2B-60DA4 to NZ2GF2BN-60DA4

This section describes the information on replacing the NZ2GF2B-60DA4 with the NZ2GF2BN-60DA4.

(1) Integration into the existing system

The terminal blocks of the NZ2GF2B-60DA4 can be installed in the NZ2GF2BN-60DA4 with the wiring left unchanged.

(2) Reusing the programs

Programs running in the NZ2GF2B-60DA4 can be reused as they are.

(3) Precautions for replacing the NZ2GF2B-60DA4 with a serial number (first five digits) of 15101 or earlier

The NZ2GF2B-60DA4 with a serial number (first five digits) of 15101 or earlier is the module designed before the addition of the trigger output function and the CC-Link IE Field Network synchronous communication function.

The remote buffer memory therefore differs in the following:

Item	NZ2GF2B-60DA4 (First five digits of the serial number are 15101 or earlier.)	NZ2GF2B-60DA4 (First five digits of the serial number are 15102 or later.), NZ2GF2BN-60DA4
Presence or absence of Mode switch (address: 0000H)	Absent	Present
Setting values of Mode switch (address: 0000H)	—	"0: Normal conversion mode" "1: Trigger output mode" "9: Automatical judgment mode" (default value)

For the NZ2GF2BN-60DA4, Mode switch (address: 0000H) is set to "9: Automatical judgment mode" by default. Hence, if the default value is left, using a master station that supports the CC-Link IE Field Network synchronous communication function results in the NZ2GF2BN-60DA4 operating in synchronous communication mode.

To operate the NZ2GF2BN-60DA4 in normal mode, change the set value of its Mode switch (address: 0000H) to "0: Normal conversion mode".

Appendix 10 External Dimensions

Appendix 10.1 Main D/A converter module

The following shows the external dimensions of the main D/A converter module.

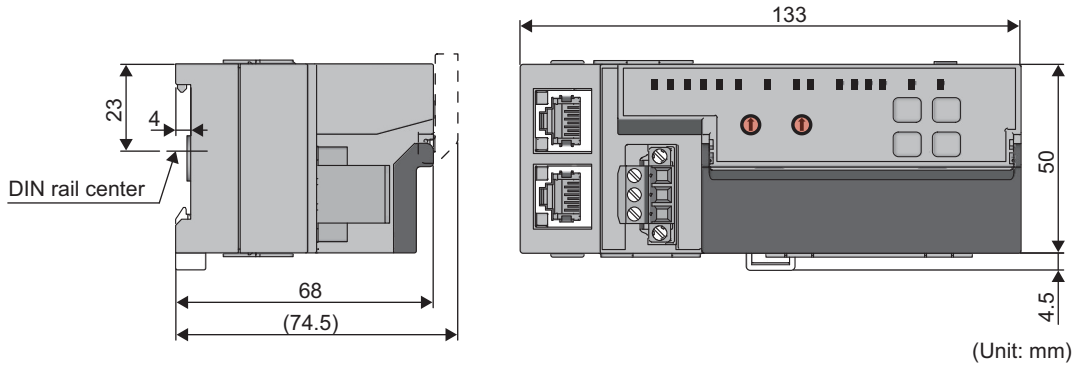

Appendix 10.2 Extension D/A converter module

The following shows the external dimensions of the extension D/A converter module.

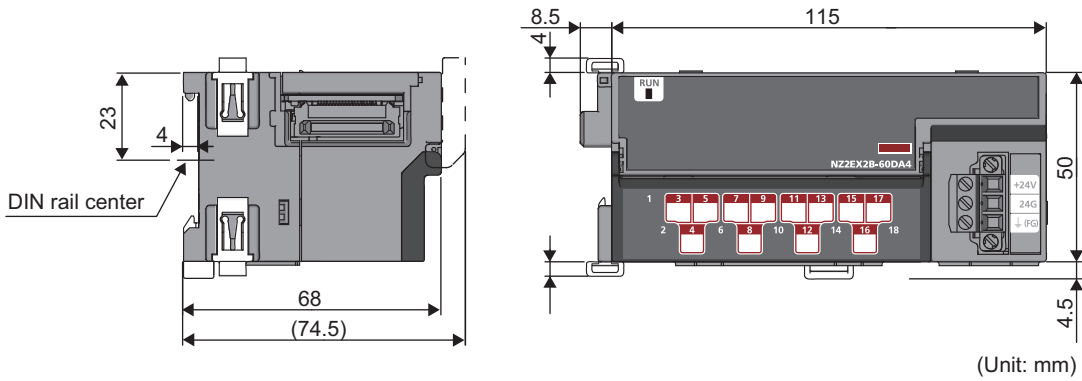

Appendix 10 External Dimensions
Appendix 10.1 Main D/A converter module

INDEX

Symbols

+/- button 20

A

Alarm code list 161
Alert output clear request flag 179
Alert output flag 182
Alert output function 107
Alert output setting 194
Alert output signal 174
Alert output signal assignment 187
ALM LED 20
Analog output HOLD/CLEAR function 93
Analog output HOLD/CLEAR setting 194
Applicable DIN rail model (compliant with IEC 60715)
. 57
Applicable systems 48
Application 15

B

Bending radius of the Ethernet cable 62

C

Cables 213
CC-Link IE Field Network diagnostic function 135
CH1 to CH4 Alert output lower limit value 195
CH1 to CH4 Alert output upper limit value 195
CH1 to CH4 Digital value 183
CH1 to CH4 LED 20
CH1 to CH4 Output enable/disable flag 178
CH1 to CH4 Scaling lower limit value 197
CH1 to CH4 Scaling upper limit value 197
CH1 to CH4 Set value check code 181
CH1 to CH4 Shifting set value 184
Checking by executing a command of the slave station
. 150
Checking by latest error code (RWr0) 153
Checking by latest warning code (RWr1) 153
Checking the LEDs 162
Connectable modules 48
Connecting an Ethernet cable 60
Current output characteristics 207
Cyclic data update watch function 95
Cyclic data update watch time setting 190

D

D LINK LED 20
D/A conversion enable/disable function 88
D/A conversion enable/disable setting 192
D/A output enable/disable function 88
Details of remote I/O signals 170
Digital output HOLD/CLEAR setting 192
Digital output HOLD/CLEAR setting function 129
Digital value range check function 105

DIN rail hook 20,22
DIN rail stopper 57

E

EMC Directive related standards 210
ERR. LED 20
Error clear request flag 177
Error code list 154
Error flag 172
Error flag assignment 188
Error history area (address: 0A00H to 0FFFH) 41
Error history clear command 199
Error history clear completed 200
Error history data 1 to 15 198
Error notification function 126
Ethernet cables 48
Extension connector cover 20
Extension module identification code 197
External dimensions 221
External power supply 214
External power supply monitor request flag 179
External power supply monitor status flag 175
External power supply monitoring function 129
External power supply READY flag 176
External signal assignment function 130

F

Features 16
Functions with an extension module connected 129

G

GAIN LED 20
Gain value 205
General specifications 23

H

How to calculate current consumption 28
How to check error codes and alarm codes 150
How to connect an extension module 53

I

I LED 20
Initial data setting completed flag 171
Initial data setting request flag 177
Input response time setting 191
Input response time setting function 129
Installation and wiring 50
Installation direction 52
Installation environment 51
Installation environment and installation position 51
Installation in a control panel 212
Installation position 51

L

L ER LED	20
Latest error code	180
Latest warning code	180
Laying Ethernet cables	62
LINK LED	20
List of remote buffer memory areas	37
List of remote I/O signals	31
List of remote registers	34

M

Maintenance and inspection	148
Maximum station-to-station distance (maximum cable length)	62
Measures to comply with the EMC Directive	210
MODE LED	20
Mode switch	185
Module control data area (address: 1000H to 14FFH)	42
Module control data area (address: 1200H to 12FFH)	44
Module operation information initialization command	203
Module operation information initialization completed	204
Monitor area (address: 0500H to 09FFH)	40
Monitor area (address: 0700H to 07FFH)	43
Mounting modules on a DIN rail	55

N

Number of ON times integration function	129
---	-----

O

O/G LED	20
OFFSET LED	20
Offset value	205
Offset/gain setting	83
Others	214

P

P1	20
P2	20
Packing list	14
Parameter area (address: 0000H to 04FFH)	39
Parameter area (address: 0200H to 02FFH)	43
Parameter area initialization command	201
Parameter area initialization completed	202
Parameter settings	69
Part names	19
Performance specifications	24
Precautions for programming	137
Procedures before operation	45
Program example	138
Programming	137
Programming procedure	138
PW LED	20

R

Range setting	193
Range switching function	92
Remote READY	173
Requirements to compliance with the Low Voltage Directive	216
RUN LED	20,22

S

Scaling enable/disable setting	196
Scaling function	96
SET/SEL button	20
Shift function	101
Station number setting	50
Station number setting switch	19
Supported master station	48
Supported software package	49
System configuration	47

T

Terminal block for analog output signals	20,22
Terminal block for external power supply and FG	22
Terminal block for module power and FG	20
Terminal cover	20,22
Terms	12
Trigger output completed clear request	178
Trigger output completed flag	173
Trigger output function	110
Trigger output request	178
Trigger output signal assignment	186
Troubleshooting	150
Troubleshooting by symptom	167

U

Unit test	166
-----------	-----

V

V LED	20
Voltage output characteristics	206

W

Warning flag	170
Warning flag assignment	189
Wiring of Ethernet cable	60
Wiring of terminal block and external devices	63
Wiring to terminal block for module power supply and FG	58

REVISIONS

*The manual number is given on the bottom left of the back cover.

Print date	*Manual number	Revision
January 2015	SH(NA)-081453ENG-A	First edition
March 2015	SH(NA)-081453ENG-B	■Added or modified parts Section 7.1, 7.2, 8.2, 9.3, 11.6.1, Appendix 3 (11)
March 2016	SH(NA)-081453ENG-C	■Added or modified parts SAFETY PRECAUTIONS, Section 2.1, 5.2, 6.5, 7.1, 7.2.1, 7.2.2, 7.3, 8.1, 8.2, 8.14, 11.4, Appendix 9.3
July 2017	SH(NA)-081453ENG-D	■Added or modified parts SAFETY PRECAUTIONS, Section 2.1, 8.17, 11.1, 11.4, Appendix 3, 10
November 2017	SH(NA)-081453ENG-E	■Added or modified parts SAFETY PRECAUTIONS, Section 2.1, 3.4, 3.5, 3.6, 8.6, 11.2, 11.3, 11.4, Appendix 2, 3, 8

Japanese manual number: SH-081452-E

This manual confers no industrial property rights or any rights of any other kind, nor does it confer any patent licenses. Mitsubishi Electric Corporation cannot be held responsible for any problems involving industrial property rights which may occur as a result of using the contents noted in this manual.

© 2015 MITSUBISHI ELECTRIC CORPORATION

WARRANTY

Please confirm the following product warranty details before using this product.

1. Gratis Warranty Term and Gratis Warranty Range

If any faults or defects (hereinafter "Failure") found to be the responsibility of Mitsubishi occurs during use of the product within the gratis warranty term, the product shall be repaired at no cost via the sales representative or Mitsubishi Service Company.

However, if repairs are required onsite at domestic or overseas location, expenses to send an engineer will be solely at the customer's discretion. Mitsubishi shall not be held responsible for any re-commissioning, maintenance, or testing on-site that involves replacement of the failed module.

[Gratis Warranty Term]

The gratis warranty term of the product shall be for one year after the date of purchase or delivery to a designated place. Note that after manufacture and shipment from Mitsubishi, the maximum distribution period shall be six (6) months, and the longest gratis warranty term after manufacturing shall be eighteen (18) months. The gratis warranty term of repair parts shall not exceed the gratis warranty term before repairs.

[Gratis Warranty Range]

- (1) The range shall be limited to normal use within the usage state, usage methods and usage environment, etc., which follow the conditions and precautions, etc., given in the instruction manual, user's manual and caution labels on the product.
- (2) Even within the gratis warranty term, repairs shall be charged for in the following cases.
 1. Failure occurring from inappropriate storage or handling, carelessness or negligence by the user. Failure caused by the user's hardware or software design.
 2. Failure caused by unapproved modifications, etc., to the product by the user.
 3. When the Mitsubishi product is assembled into a user's device, Failure that could have been avoided if functions or structures, judged as necessary in the legal safety measures the user's device is subject to or as necessary by industry standards, had been provided.
 4. Failure that could have been avoided if consumable parts (battery, backlight, fuse, etc.) designated in the instruction manual had been correctly serviced or replaced.
 5. Failure caused by external irresistible forces such as fires or abnormal voltages, and Failure caused by force majeure such as earthquakes, lightning, wind and water damage.
 6. Failure caused by reasons unpredictable by scientific technology standards at time of shipment from Mitsubishi.
 7. Any other failure found not to be the responsibility of Mitsubishi or that admitted not to be so by the user.

2. Onerous repair term after discontinuation of production

- (1) Mitsubishi shall accept onerous product repairs for seven (7) years after production of the product is discontinued. Discontinuation of production shall be notified with Mitsubishi Technical Bulletins, etc.
- (2) Product supply (including repair parts) is not available after production is discontinued.

3. Overseas service

Overseas, repairs shall be accepted by Mitsubishi's local overseas FA Center. Note that the repair conditions at each FA Center may differ.

4. Exclusion of loss in opportunity and secondary loss from warranty liability

Regardless of the gratis warranty term, Mitsubishi shall not be liable for compensation to:

- (1) Damages caused by any cause found not to be the responsibility of Mitsubishi.
- (2) Loss in opportunity, lost profits incurred to the user by Failures of Mitsubishi products.
- (3) Special damages and secondary damages whether foreseeable or not, compensation for accidents, and compensation for damages to products other than Mitsubishi products.
- (4) Replacement by the user, maintenance of on-site equipment, start-up test run and other tasks.

5. Changes in product specifications

The specifications given in the catalogs, manuals or technical documents are subject to change without prior notice.

TRADEMARKS

Ethernet is a registered trademark of Fuji Xerox Co., Ltd. in Japan.

The company names, system names and product names mentioned in this manual are either registered trademarks or trademarks of their respective companies.

In some cases, trademark symbols such as [™] or [®] are not specified in this manual.

SH(NA)-081453ENG-E(1711)MEE

MODEL: CCIEF-N-DA-U-E

MODEL CODE: 13JX27

mitsubishi electric corporation

HEAD OFFICE : TOKYO BUILDING, 2-7-3 MARUNOUCHI, CHIYODA-KU, TOKYO 100-8310, JAPAN
NAGOYA WORKS : 1-14, YADA-MINAMI 5-CHOME, HIGASHI-KU, NAGOYA, JAPAN

When exported from Japan, this manual does not require application to the
Ministry of Economy, Trade and Industry for service transaction permission.

Specifications subject to change without notice.