

FUJI AC SERVO SYSTEM
FALDIC- α
Series

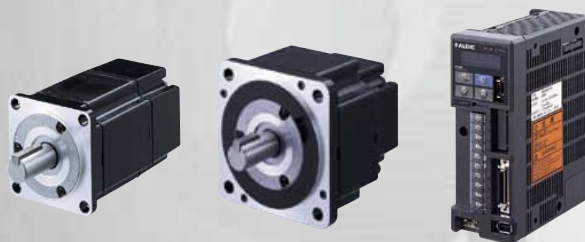



FUJI AC SERVO SYSTEM
FALDIC- α
Series

Model line up
SERVOMOTOR

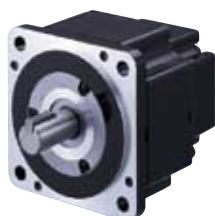

Cubic type

Having a drastically shorter depth, the motor does not remarkably protrude to the rear of the machine when mounted.



Slim type

A small flange allows the motor to fit into a small area.

CONTENTS

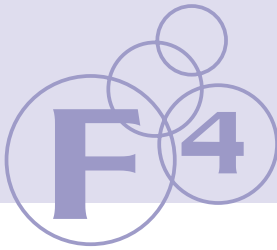

Fuji's compact servo system, packed with advanced control technologies, meets new industry standards.

The new FALDIC- series has come onstage with enhanced fundamental functions and a variety of other useful functions such as an easy-to-operate PC loader and real-time tuning of the mechanical systems. These help shorten your setup time as well as improve your machine's performance.

Features of the FALDIC- α

Fine

Frequency response at 600Hz and a settling time of 1 ms provide amazing control capability. The servo motor incorporates a real-time tuning function to automatically adjust the gain even when the moment of load inertia fluctuates.

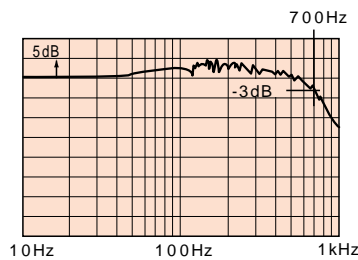

Friendly

From the selection of a suitable servo motor capacity, to test operation of the motor, maintenance and inspection, as well as diagnosis of alarms, the personal computer loader helps navigate you through all processes. The servo amplifiers radiate less heat horizontally and can be installed side by side with very little or no clearance between them. (If they are completely fitted to each other, however, the cyclic duty factor will be reduced to 80%ED.)



Flexible

The servo motor, equipped with a 16-bit serial encoder which can be used for both incremental and absolute position feedback systems, requires less wiring and keeps the motor wow at low level.

The encoder connects with four cables: two for power and two for signals. (To construct an absolute position feedback system, however, two other lines are required to connect with the battery.)

The motor can be operated in combination with the encoder without changing the encoder settings, even though such combination is not specified as the standard combination.

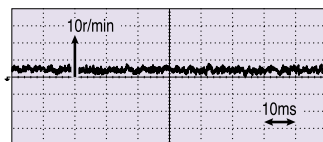

Facility

The servomotors are so compactly designed that they can be mounted even in a small area. Servo amplifiers are available in three types; velocity control, linear positioning, and rotation angle index type. Choose one according to your needs. The servomotors meet foreign standards. (The standard model meets CE marking and is planning to achieve UL/cUL standards.)



SERVO AMPLIFIER



V type (Velocity)

Servo amplifier for motor velocity control using a pulse train or speed command

The amplifier rotates the motor according to the specified pulse train command or analog speed command issued from the host control unit.



L type (Linear motion)

Servo amplifier with linear positioning function

You can construct a linear positioning system using such machine components as a ball screw or rack & pinion.



R type (Rotation)

Servo amplifier with rotation angle indexing function

You can construct a rotation angle index system such as that for an ATC, tool magazine, or transfer unit.

SERVOMOTOR

16-bit serial encoder

The servomotor is standard-equipped with a 4Mbps serial encoder that can generate 65536 pulses/revolution. These components are connected with only four wires.

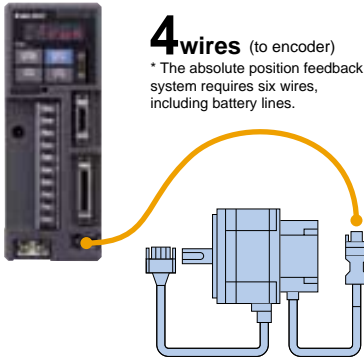

Specifications common to 50W to 5kW

There are two types of motors: a cubic type (ranging from 100W to 2kW) with a short depth, and a slim type with a small flange. Using both types, you can select a motor with a brake or a gear head.

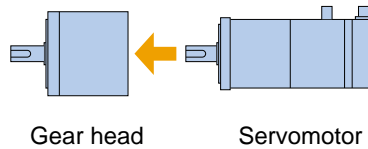

High-speed response and low motor wow

The power rate of the slim type is 65kW/s. The motor returns to the rated speed by accelerating or decelerating in approximately 2ms. (0.4kW servomotor, no load at shaft end) A 16-bit serial encoder keeps the motor wow at a low level by generating 65536 pulses.

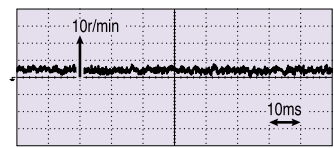

SERVO AMPLIFIER

Servo amplifier can be used for incremental and absolute position feedback

An absolute position feedback system can be constructed by connecting a battery to the servo amplifier.

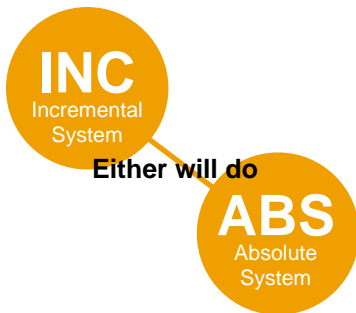

Automatic detection of servomotor type

The amplifier detects the motor type (cubic or slim) and the motor capacity. Therefore, you can operate the motor simply by supplying power to the amplifier.

- The servomotor and the servo amplifier are ranked at the same capacity level.
- The servomotor is ranked higher or lower than the servo amplifier by one capacity level (3-phase 200V series).

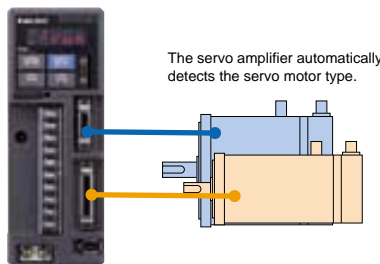

High-speed response

The amplifier detects changes in the status of the ON/OFF control signal in 1ms.

The amplifier quickly responds to the signal change sent from the host control unit.

The amplifier achieves a frequency response of 600Hz by combining with a low inertia motor.

Personal computer loader

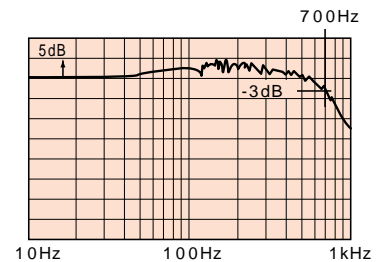

Personal computer loader

Monitor

When you connect the personal computer loader and the servo amplifier, you can continuously monitor the servo amplifier operating condition. Both real-time trace and historical trace are available as a monitoring method.





Application Examples

FALDIC- series are used in the following applications.

PC board inspecting machine

This machine moves the printed circuit board sequentially so that a camera can properly capture the portion to be inspected. The board moves in the registration order of position data.

Control method:
synchronized operation, linear positioning

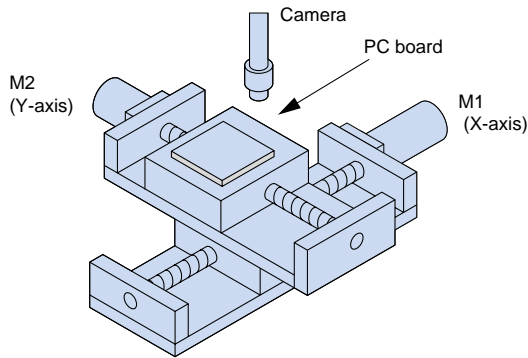

Horizontal pillow-type packaging machine

This machine packages a piece of bread or the like one by one. The machine pulls and rolls a sheet of film like a pillow, packages a product in it, and then seals and cuts the film. The servo system determines the sealer and conveyor positions in synchronization with the film pulling motion.

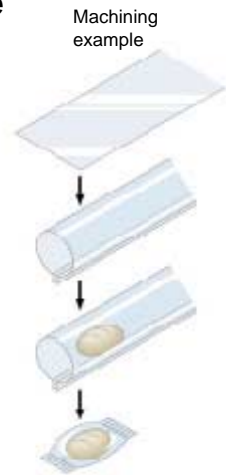

Control method:
synchronized operation

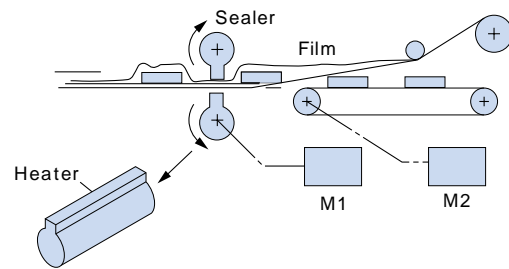

Staggered holes drilling machine

This machine drills holes in staggered positions on a pipe. The servo system controls the vertical travel and rotation speed of a drill and the front-back movement and rotation of a pipe.



Control method:
linear and rotary positioning

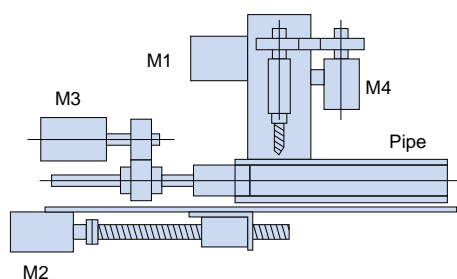

ATC (automatic tool changer)

This unit automatically changes the tools on the machine tool. When a tool number is given, the servo system indexes the relevant tool to the tool change position. The system can index the tool by rotating the turret either in one direction or in whichever direction closer to the tool change position. On completion of indexing, the ATC mechanically locks the turret.

Control method:
rotation angle indexing

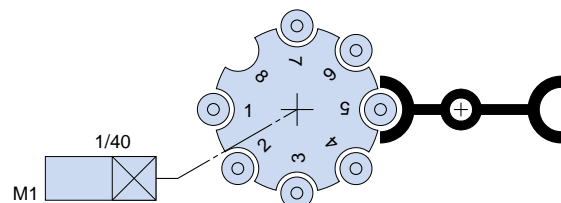

Description of Functions

Functions of the Personal Computer Loader and Servo Amplifier

| Loader functions | | Specifications |
|--------------------------|----------------------------|---|
| Monitor 1 | Historical trace | Sampling time: 1, 2, 5, 10, 20, 50, 100, and 200ms Min. sampling time: 1ms. Data capacity: 100 points |
| | Real-time trace | Sampling time: 50, 100, and 200ms Min. sampling time: 50ms. Data capacity: 25000 points |
| | Saving monitored waveforms | Monitored data can be saved in a file or printed. * Saving in a waveform format such as CSV is possible. |
| Monitor 2 | I/O monitor | Graphically displays the ON/OFF status of control input/output signals. |
| | I/O link monitor | Graphically displays the ON/OFF status of signals in links such as T-link or SX bus. |
| | System monitor | Displays the servo amplifier and servomotor types and their major functions. |
| Test operation | | Manual feed, zero return, pulse train feed, etc. |
| Parameter editing | List edit | Allows you to edit standard and system parameters in numerical order. |
| | Editing for each function | Allows you to edit standard and system parameters that are classified by function. |
| | Comparison | Compares the data being edited with servo amplifier data and file data. (Possible to comparatively display the results.) |
| | Initialization | Initializes servo amplifier parameters and the data being edited. |
| | File information | Displays the parameter information being edited. |
| | Data transfer | Transfers all data or only changed data. |
| Editing positioning data | | Editing positioning data Editing position, feed rate, timer, M code, and status data |
| Diagnosis | | Alarm type (on-line data display of alarm cause, remedy, and time of alarm detection) No alarm (on-line data display of the cause of such trouble as non-operation or vibration, and the remedy) |

| Servo amplifier functions | Specifications |
|---------------------------|---|
| Sampling data | Analog data and control input/output signals (ON/OFF) |
| Data capacity | 100 points |
| Storage of memory | Cyclic |
| Sampling interval | 1, 2, 5, 10, 20, 50, 100, and 200ms (set on the loader) |
| Start/stop | Trigger conditions (set on the loader) |



Description of Functions

| | | |
|--|--|--|
| <p>Soft start</p> <p>The motor rotates and stops smoothly in the preset acceleration/deceleration time. External signals can be used to change the start/stop conditions.</p> <p>L R V</p> | <p>Switching the direction of rotation</p> <p>The motor rotation direction can be switched between forward and reverse, without the need to change the wiring.</p> <p>L R V</p> | <p>Pulse offset function</p> <p>The set value becomes the actual travel of a mechanism.</p> <p>L</p> |
| <p>Current limit function</p> <p>The output current (torque) can be limited by an external signal. This function is used to prevent damage to the machine.</p> <p>L R V</p> | <p>Programmable terminal</p> <p>Required functions can be assigned to the input/output terminals. You can select the signals required for your machine's operation.</p> <p>L R V</p> | <p>One-point stop</p> <p>The motor can stop the rotary axis at a specified position. In addition, it can index the rotary axis to a maximum 30,000 divisions.</p> <p>R</p> |
| <p>Brake timing</p> <p>The motor incorporates brake excitation and release timers.</p> <p>L R V</p> | <p>Alarm history</p> <p>The amplifier retains records of the last nine alarms. Refer to this for easy maintenance and inspection.</p> <p>L R V</p> | <p>Positioning by interruption</p> <p>You can stop the motor after sending a fixed amount of pulses with an external signal.</p> <p>L V</p> |

System Configuration

Applicable to various host interfaces

The servo amplifier can be directly connected to various networks. The MICREX-SX system can be loaded with the pulse train output module and various compound modules. The SX system is also equipped with a function board for simple positioning; that for 4-axis interpolation, and that for cutting-off.

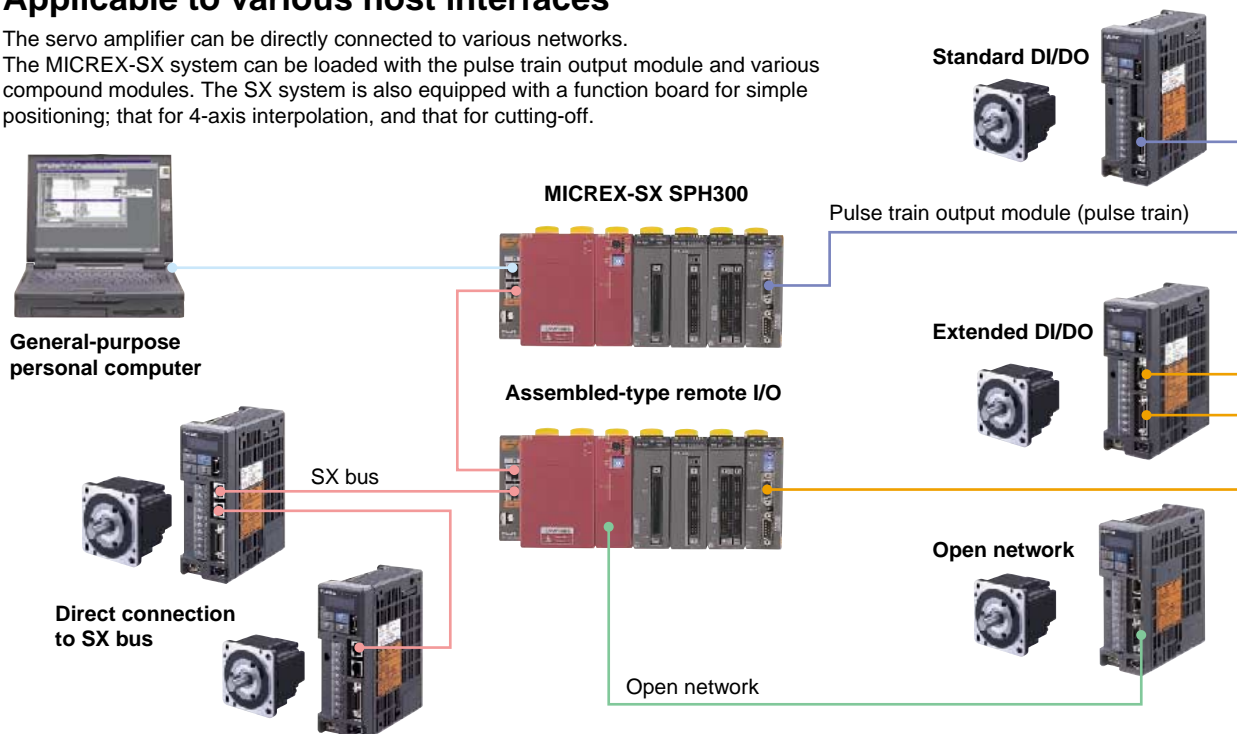

SERVO MOTOR 200V series

[Cubic type] 0.1~2kW

Standard type

| Motor type | | GYC101DC1-SA | GYC201DC1-SA | GYC401DC1-SA | GYC751DC1-SA |
|--------------------------------|----------------------|---|-------------------------|-------------------------|------------------------|
| Rated output | [kW] | 0.1 | 0.2 | 0.4 | 0.75 |
| Rated torque | [N·m] | 0.318 | 0.637 | 1.27 | 2.39 |
| Rated speed | [r/min] | 3000 | | | |
| Max. speed | [r/min] | 5000 | | | |
| Max. torque | [Nm] | 0.955/1.43 | 1.91/2.87 | 3.82/5.73 | 7.17/10.7 |
| Moment of inertia | [kg·m ²] | 0.00538×10 ⁻³ | 0.0216×10 ⁻³ | 0.0412×10 ⁻³ | 0.121×10 ⁻³ |
| Rated Current | [A] | 1.0 | 1.5 | 2.6 | 4.8 |
| Max. Current | [A] | 3.0/4.5 | 4.5/6.8 | 7.8/11.8 | 14.4/21.6 |
| Winding insulation class | | B | | | |
| Operation duty type | | Continuous | | | |
| Degree of enclosure protection | | Totally enclosed, self cooled (IP55) | | | |
| Terminals (motor) | | With 0.3-m flexible leads and connectors | | | |
| Terminals (encoder) | | With 0.3-m flexible leads and connectors | | | |
| Overheat protection | | Not provided (Servo amplifier detects temperature.) | | | |
| Mounting method | | By securing motor flange IMB5 (L51), IMV1 (L52), IMV3 (L53) | | | |
| Shaft extension | | Straight shaft with a key | | | |
| Paint color | | Munsell N1.5 (flat paint) | | | |
| Encoder | | 16-bit serial encoder (Possible to construct ABS system by connecting a battery to the servo amplifier.) | | | |
| Vibration level | | V5 or under | | | |
| Installation place, altitude | | For indoor use, 1000m or below | | | |
| Ambient temperature, humidity | | -10 to +40°C, 90% RH max. (without condensation) | | | |
| Vibration resistance | [m/s ²] | 49 | | | |
| Mass | [kg] | 0.75 | 1.3 | 1.9 | 3.5 |

Note: Motors with a capacity of 3.0 kW or over are under development.

Motor with a brake

| Motor type | | GYC101DC1-SA-B | GYC201DC1-SA-B | GYC401DC1-SA-B | GYC751DC1-SA-B |
|------------------|-------|----------------|----------------|----------------|----------------|
| Rated output | [kW] | 0.1 | 0.2 | 0.4 | 0.75 |
| Rated torque | [N·m] | 0.318 | 0.637 | 1.27 | 2.39 |
| Braking torque | [N·m] | 0.318 | 1.27 | 1.27 | 2.39 |
| Rated DC voltage | [V] | 24V DC | | | |
| Attraction time | [ms] | 60 | 80 | 80 | 50 |
| Release time | [ms] | 40 | 40 | 40 | 80 |
| Braking power | [W] | 6.5 | 9 | 9 | 8.5 |
| Mass | [kg] | 1 | 1.9 | 2.6 | 4.3 |

Note: The brake is used to hold the rotor.

Gear head (gear ratio 1/9)

| Gear head type | | GYN101CAG-G09 | GYN201CAG-G09 | GYN401CAG-G09 | GYN751CAG-G09 |
|------------------------------|---------|-------------------------------------|---------------|---------------|---------------|
| Actual speed reduction ratio | | 1/9 | | | |
| Rated speed | [r/min] | 333.3 | | | |
| Max. speed | [r/min] | 555.5 | | | |
| Rated torque | [N·m] | 2.45 | 4.9 | 9.8 | 18.1 |
| Breakdown (max.) torque | [N·m] | 7.35 | 14.7 | 29.4 | 54.4 |
| Direction of motor rotation* | | CCW | | | |
| Backlash | [min] | Max. 40 | Max. 30 | | |
| Lubrication | | Long-life grease (Sumiplex MP No.2) | | | |
| Mass | [kg] | 0.72 | 2.1 | 2.1 | 3.8 |

*: When the motor shaft rotates forward, the gear output shaft rotates in CCW (counter-clockwise) direction.

Gear head (gear ratio 1/25, 1/15)

| Gear head type | | GYN101CAG-G25 | GYN201CAG-G25 | GYN401CAG-G25 | GYN751CAG-G25 |
|------------------------------|---------|-------------------------------------|---------------|---------------|---------------|
| Actual speed reduction ratio | | 1/25 | | | |
| Rated speed | [r/min] | 120 | | | |
| Max. speed | [r/min] | 200 | | | |
| Rated torque | [N·m] | 6.37 | 12.7 | 25.5 | 48 |
| Breakdown (max.) torque | [N·m] | 19.1 | 38.2 | 76.4 | 144 |
| Direction of motor rotation* | | CCW | | | |
| Backlash | [min] | Max. 40 min. | Max. 30 min. | | |
| Lubrication | | Long-life grease (Sumiplex MP No.2) | | | |
| Mass | [kg] | 0.72 | 2.1 | 2.1 | 3.8 |

*: When the motor shaft rotates forward, the gear output shaft rotates in CCW (counter-clockwise) direction.

| Motor type | GYC102DC1-SA | GYC152DC1-SA | GYC202DC1-SA |
|--|---|------------------------|------------------------|
| Rated output [kW] | 1.0 | 1.5 | 2.0 |
| Rated torque [N·m] | 3.18 | 4.78 | 6.37 |
| Rated speed [r/min] | 3000 | | |
| Max. speed [r/min] | 5000 | | |
| Max. torque [N·m] | 9.55/12.7 | 14.3/19.1 | 19.1 |
| Moment of inertia [kg·m ²] | 0.326×10 ⁻³ | 0.451×10 ⁻³ | 0.575×10 ⁻³ |
| Rated Current [A] | 6.7 | 9.6 | 12.6 |
| Max. Current [A] | 20.1/26.8 | 28.8/38.4 | 37.8 |
| Winding insulation class | F | | |
| Operation duty type | Continuous | | |
| Degree of enclosure protection | Totally enclosed, self cooled (IP55) | | |
| Terminals (motor) | With cannon connectors | | |
| Terminals (encoder) | With cannon connectors | | |
| Overheat protection | Not provided (Servo amplifier detects temperature.) | | |
| Mounting method | By securing motor flange IMB5 (L51), IMV1 (L52), IMV3 (L53) | | |
| Shaft extension | Straight shaft with a key | | |
| Paint color | Munsell N1.5 (flat paint) | | |
| Encoder | 16-bit serial encoder (Possible to construct ABS system by connecting a battery to the servo amplifier.) | | |
| Vibration level | Max. V10 (3000 r/min or less), Max. V15 (3001 to 5000 r/min) | | |
| Installation place, altitude | For indoor use, 1000m or below | | |
| Ambient temperature, humidity | -10 to +40°C, 90% RH max. (without condensation) | | |
| Vibration resistance [m/s ²] | 24.5m/s ² | | |
| Mass [kg] | 5.7 | 7.0 | 8.2 |

| Motor type | GYC102DC1-SA-B | GYC152DC1-SA-B | GYC202DC1-SA-B |
|----------------------|----------------|----------------|----------------|
| Rated output [kW] | 1.0 | 1.5 | 2.0 |
| Rated torque [N·m] | 3.18 | 4.78 | 6.37 |
| Braking torque [N·m] | 17 | | |
| Rated DC voltage [V] | 24V DC | | |
| Attraction time [ms] | 120 | 120 | 120 |
| Release time [ms] | 30 | 30 | 30 |
| Braking power [W] | 12 | 12 | 12 |
| Mass [kg] | 8.0 | 9.8 | 11.0 |

| Gear head type | GYN102CAG-G09 | GYN152CAG-G09 | GYN202CAG-G09 |
|-------------------------------|-------------------------------------|---------------|---------------|
| Actual speed reduction ratio | 1/9 | | |
| Rated speed [r/min] | 333.3 | | |
| Max. speed [r/min] | 555.5 | | |
| Rated torque [N·m] | 25.4 | 38.2 | 50.9 |
| Breakdown (max.) torque [N·m] | 76.4 | 114 | 152 |
| Direction of motor rotation* | CCW | | |
| Backlash [min] | Max. 30 | | |
| Lubrication | Long-life grease (Sumiplex MP No.2) | | |
| Mass [kg] | 7.8 | 7.8 | 12.2 |

*: When the motor shaft rotates forward, the gear output shaft rotates in CCW (counter-clockwise) direction.

| Gear head type | GYN102CAG-G15 | GYN152CAG-G15 | GYN202CAG-G15 |
|-------------------------------|-------------------------------------|---------------|---------------|
| Actual speed reduction ratio | 1/15 | | |
| Rated speed [r/min] | 200 | | |
| Max. speed [r/min] | 333.3 | | |
| Rated torque [N·m] | 39.2 | 57.8 | 77.4 |
| Breakdown (max.) torque [N·m] | 117 | 173 | 232 |
| Direction of motor rotation* | CCW | | |
| Backlash [min] | Max. 30 | | |
| Lubrication | Long-life grease (Sumiplex MP No.2) | | |
| Mass [kg] | 7.8 | 7.8 | 12.2 |

*: When the motor shaft rotates forward, the gear output shaft rotates in CCW (counter-clockwise) direction.

SERVO MOTOR 200V series

[Slim Type type] 0.05~5kW

■Standard type

| Motor type | GYS500DC1-S8B | GYS101DC1-SB | GYS201DC1-SA | GYS401DC1-SA | GYS751DC1-SA |
|--|---|--------------------------|---------------------------|-------------------------|-------------------------|
| Rated output [kW] | 0.05 | 0.1 | 0.2 | 0.4 | 0.75 |
| Rated torque [N·m] | 0.159 | 0.318 | 0.637 | 1.27 | 2.39 |
| Rated speed [r/min] | 3000 | | | | |
| Max. speed [r/min] | 5000 | | | | |
| Max. torque [Nm] | 0.478 | 0.955 | 1.91/2.87 | 3.82/5.73 | 7.17/10.7 |
| Moment of inertia [kg·m ²] | 0.00341×10 ⁻³ | 0.00517×10 ⁻³ | 0.0137×10 ⁻³ | 0.0249×10 ⁻³ | 0.0861×10 ⁻³ |
| Rated Current [A] | 0.85 | 0.85 | 1.5 | 2.6 | 4.8 |
| Max. Current [A] | 2.55 | 2.55 | 4.5/6.8 | 7.8/11.8 | 14.4/21.6 |
| Winding insulation class | B | | | | |
| Operation duty type | Continuous | | | | |
| Degree of enclosure protection | Totally enclosed, self cooled (IP55) | | | | |
| Terminals (motor) | With 0.3-m flexible leads and connectors | | | | |
| Terminals (encoder) | With 0.3-m flexible leads and connectors | | | | |
| Overheat protection | Not provided (Servo amplifier detects temperature.) | | | | |
| Mounting method | By securing motor flange IMB5 (L51), IMV1 (L52), IMV3 (L53) | | | | |
| Shaft extension | Straight shaft without key | | Straight shaft with a key | | |
| Paint color | Munsell N1.5 (flat paint) | | | | |
| Encoder | 16-bit serial encoder (Possible to construct ABS system by connecting a battery to the servo amplifier.) | | | | |
| Vibration level | V5 or under | | | | |
| Installation place, altitude | For indoor use, 1000m or below | | | | |
| Ambient temperature, humidity | -10 to +40°C, 90% RH max. (without condensation) | | | | |
| Vibration resistance | 49m/s ² | | | | |
| Mass [kg] | 0.45 | 0.55 | 1.2 | 1.8 | 3.4 |

Notes: 1) Contact your nearest sales office for 0.03kW motor.
2) The 0.05kW motor is shared with 100V series.

3) Select the shaft with a key only when using 50W or 100W motor in combination with a gear head.

■Motor with a brake

| Motor type | GYS500DC1-S8B-B | GYS101DC1-SB-B | GYS201DC1-SA-B | GYS401DC1-SA-B | GYS751DC1-SA-B |
|----------------------|-----------------|----------------|----------------|----------------|----------------|
| Rated output [kW] | 0.05 | 0.1 | 0.2 | 0.4 | 0.75 |
| Rated torque [N·m] | 0.159 | 0.318 | 0.637 | 1.27 | 2.39 |
| Braking torque [N·m] | 0.3 | | 1.27 | 1.27 | 2.45 |
| Rated DC voltage [V] | 24V DC | | | | |
| Attraction time [ms] | 35 | | 40 | 40 | 60 |
| Release time [ms] | 10 | | 20 | 20 | 25 |
| Braking power [W] | 6.1 | | 7.3 | 7.3 | 8.5 |
| Mass [kg] | 0.62 | 0.72 | 1.7 | 2.3 | 4.2 |

Notes: 1) The 0.05 kW motor is shared with 100V series. 2) The brake is used to hold the rotor.

■Gear head (gear ratio 1/9)

| Gear head type | GYN500SAG-G09 | GYN101SAG-G09 | GRN.20SAG-G09 | GRN.40SAG-G09 | GRN751SAG-G09 |
|-------------------------------|-------------------------------------|---------------|---------------|---------------|---------------|
| Actual speed reduction ratio | 1/9 | | | | |
| Rated speed [r/min] | 333.3 | | | | |
| Max. speed [r/min] | 555.5 | | | | |
| Rated torque [N·m] | 1.23 | 2.45 | 4.9 | 9.8 | 18.1 |
| Breakdown (max.) torque [N·m] | 3.68 | 7.36 | 14.7 | 29.4 | 54.3 |
| Direction of motor rotation* | CCW | | | | |
| Backlash [min] | Max. 40 | | Max. 30 | | |
| Lubrication | Long-life grease (Sumiplex MP No.2) | | | | |
| Mass [kg] | 0.7 | 0.7 | 2.1 | 2.1 | 3.8 |

*: When the motor shaft rotates forward, the gear output shaft rotates in CCW (counter-clockwise) direction.

■Gear head (gear ratio 1/25, 1/15)

| Gear head type | GYN500SAG-G25 | GYN101SAG-G25 | GRN.20SAG-G25 | GRN.40SAG-G25 | GYN751SAG-G25 |
|-------------------------------------|-------------------------------------|---------------|---------------|---------------|---------------|
| Actual speed reduction ratio | 1/25 | | | | |
| Rated speed [r/min] | 120 | | | | |
| Max. speed [r/min] | 200 | | | | |
| Rated torque [N·m] | 3.19 | 6.38 | 12.7 | 25.5 | 48 |
| Breakdown (max.) torque [N·m] | 9.56 | 19.1 | 38.2 | 76.4 | 144 |
| Rotating direction of output shaft* | CCW | | | | |
| Backlash [min] | Max. 40 | | Max. 30 | | |
| Lubrication | Long-life grease (Sumiplex MP No.2) | | | | |
| Mass [kg] | 0.7 | 0.7 | 2.1 | 2.1 | 3.8 |

*: When the motor shaft rotates forward, the gear output shaft rotates in CCW (counter-clockwise) direction.

| Motor type | GYS102DC1-SA | GYS152DC1-SA | GYS202DC1-SA | GYS302DC1-SA | GYS402DC1-SA | GYS502DC1-SA |
|--|---|------------------------|------------------------|------------------------|-----------------------|-----------------------|
| Rated output [kW] | 1.0 | 1.5 | 2.0 | 3.0 | 4.0 | 5.0 |
| Rated torque [N·m] | 3.18 | 4.78 | 6.37 | 9.55 | 12.7 | 15.9 |
| Rated speed [r/min] | 3000 | | | | | |
| Max. speed [r/min] | 5000 | | | | | |
| Max. torque [N·m] | 9.55/12.7 | 14.3/19.1 | 19.1 | 28.7 | 38.2 | 47.8 |
| Moment of inertia [kg·m ²] | 0.174×10 ⁻³ | 0.238×10 ⁻³ | 0.302×10 ⁻³ | 0.873×10 ⁻³ | 1.12×10 ⁻³ | 1.37×10 ⁻³ |
| Rated Current [A] | 7.1 | 9.6 | 12.6 | 18.5 | 24.5 | 30 |
| Max. Current [A] | 21.3/28.4 | 28.8/38.4 | 37.8 | 55.5 | 73.5 | 90 |
| Winding insulation class | F | | | | | |
| Operation duty type | Continuous | | | | | |
| Degree of enclosure protection | Totally enclosed, self cooled (IP55) | | | | | |
| Terminals (motor) | With cannon connectors | | | | | |
| Terminals (encoder) | With cannon connectors | | | | | |
| Overheat protection | Not provided (Servo amplifier detects temperature.) | | | | | |
| Mounting method | By securing motor flange IMB5 (L51), IMV1 (L52), IMV3 (L53) | | | | | |
| Shaft extension | Straight shaft with a key | | | | | |
| Paint color | Munsell N1.5 (flat paint) | | | | | |
| Encoder | 16-bit serial encoder (Possible to construct ABS system by connecting a battery to the servo amplifier.) | | | | | |
| Vibration level | Max. V10 (3000 r/min or less), Max. V15 (3001 to 5000 r/min) | | | | | |
| Installation place, altitude | For indoor use, 1000m or below | | | | | |
| Ambient temperature, humidity | -10 to +40°C, 90% RH max. (without condensation) | | | | | |
| Vibration resistance | 24.5m/s ² | | | | | |
| Mass [kg] | 4.4 | 5.2 | 6.3 | 11.0 | 13.5 | 16.0 |

| Motor type | GYS102DC1-SA-B | GYS152DC1-SA-B | GYS202DC1-SA-B | GYS302DC1-SA-B | GYS402DC1-SA-B | GYS502DC1-SA-B |
|----------------------|----------------|----------------|----------------|----------------|----------------|----------------|
| Rated output [kW] | 1.0 | 1.5 | 2.0 | 3.0 | 4.0 | 5.0 |
| Rated torque [N·m] | 3.18 | 4.78 | 6.37 | 9.55 | 12.7 | 15.9 |
| Braking torque [N·m] | 6.86 | 6.86 | 17 | 17 | 17 | 17 |
| Rated DC voltage [V] | 24V DC | | | | | |
| Attraction time [ms] | 60 | 60 | 120 | 120 | 120 | 120 |
| Release time [ms] | 10 | 10 | 30 | 30 | 30 | 30 |
| Braking power [W] | 17 | 17 | 12 | 12 | 12 | 12 |
| Mass [kg] | 5.9 | 6.8 | 7.9 | 13.0 | 15.5 | 18.0 |

| Gear head type | GYN102SAG-G09 | GYN152SAG-G09 | GYN202SAG-G09 | GYN302SAG-G09 | GYN402SAG-G09 | GYN502SAG-G09 |
|-------------------------------|-------------------------------------|---------------|---------------|---------------|---------------|---------------|
| Actual speed reduction ratio | 1/9 | | | | | |
| Rated speed [r/min] | 333.3 | | | | | |
| Max. speed [r/min] | 555.5 | | | | | |
| Rated torque [N·m] | 25.4 | 38.2 | 50.9 | | | |
| Breakdown (max.) torque [N·m] | 74.4 | 114 | 152 | | | |
| Direction of motor rotation* | CCW | | | | | |
| Backlash [min] | Max. 30 | | | | | |
| Lubrication | Long-life grease (Sumiplex MP No.2) | | | | | |
| Mass [kg] | 7.8 | 7.8 | 7.8 | | | |

Under planning

*: When the motor shaft rotates forward, the gear output shaft rotates in CCW (counter-clockwise) direction.

| Gear head type | GYN102SAG-G15 | GYN152SAG-G15 | GYN202SAG-G15 | GYN302SAG-G15 | GYN402SAG-G15 | GYN502SAG-G15 |
|-------------------------------------|-------------------------------------|---------------|---------------|---------------|---------------|---------------|
| Actual speed reduction ratio | 1/15 | | | | | |
| Rated speed [r/min] | 200 | | | | | |
| Max. speed [r/min] | 333.3 | | | | | |
| Rated torque [N·m] | 39.2 | 57.8 | 77.4 | | | |
| Breakdown (max.) torque [N·m] | 117 | 173 | 232 | | | |
| Rotating direction of output shaft* | CCW | | | | | |
| Backlash [min] | Max. 30 | | | | | |
| Lubrication | Long-life grease (Sumiplex MP No.2) | | | | | |
| Mass [kg] | 7.8 | 7.8 | 7.8 | | | |

Under planning

*: When the motor shaft rotates forward, the gear output shaft rotates in CCW (counter-clockwise) direction.

SERVO MOTOR 100V series

[Slim Type] 0.05~0.2kW

■Standard type

| Motor type | | GYS500DC1-S8B | GYS101DC1-S6B | GYS201DC1-S6B |
|--------------------------------|----------------------|--|--------------------------|-------------------------|
| Rated output | [kW] | 0.05 | 0.1 | 0.2 |
| Rated torque | [N·m] | 0.159 | 0.318 | 0.637 |
| Rated speed | [r/min] | 3000 | | |
| Max. speed | [r/min] | 5000 | | |
| Max. torque | [N·m] | 0.478 | 0.955 | 1.91 |
| Moment of inertia | [kg·m ²] | 0.00341×10 ⁻³ | 0.00517×10 ⁻³ | 0.0137×10 ⁻³ |
| Rated Current | [A] | 0.85 | 1.5 | 2.7 |
| Max. Current | [A] | 2.55 | 4.5 | 8.1 |
| Winding insulation class | | B | | |
| Operation duty type | | Continuous | | |
| Degree of enclosure protection | | Totally enclosed, self cooled (IP55) | | |
| Terminals (motor) | | With 0.3-m flexible leads and connectors | | |
| Terminals (encoder) | | With 0.3-m flexible leads and connectors | | |
| Overheat protection | | Not provided (Servo amplifier detects temperature.) | | |
| Mounting method | | By securing motor flange IMB5 (L51), IMV1 (L52), IMV3 (L53) | | |
| Shaft extension | | Straight shaft without key | | |
| Paint color | | Munsell N1.5 (flat paint) | | |
| Encoder | | 16-bit serial encoder (Possible to construct ABS system by connecting a battery to the servo amplifier.) | | |
| Vibration level | | V5 or under | | |
| Installation place, altitude | | For indoor use, 1000m or below | | |
| Ambient temperature, humidity | | -10 to +40°C, 90% RH max. (without condensation) | | |
| Vibration resistance | | 49m/s ² | | |
| Mass | [kg] | 0.45 | 0.55 | 1.2 |

Note: The 0.05 kW motor is shared with 200V series

■Motor with a brake

| Motor type | | GYS500DC1-S8B-B | GYS101DC1-S6B-B | GYS201DC1-S6B-B |
|------------------|-------|-----------------|-----------------|-----------------|
| Rated output | [kW] | 0.05 | 0.1 | 0.2 |
| Rated torque | [N·m] | 0.159 | 0.318 | 0.637 |
| Braking torque | [N·m] | 0.3 | 0.3 | 1.27 |
| Rated DC voltage | [V] | 24V DC | | |
| Attraction time | [ms] | 35 | 35 | 40 |
| Release time | [ms] | 10 | 10 | 20 |
| Braking power | [W] | 6.1 | 6.1 | 7.3 |
| Mass | [kg] | 0.62 | 0.72 | 1.7 |

Note: The 0.05 kW motor is shared with 200V series.

SERVO AMPLIFIER (3-phase 200V Series)

Basic type

| Amplifier type | RYS500S3-□□S | RYS101S3-□□S | RYS201S3-□□S | RYS401S3-□□S | RYS751S3-□□S |
|------------------------------|---|--|----------------------------------|--------------|--------------|
| Applicable motor output [kW] | 0.05 | 0.1 | 0.2 | 0.4 | 0.75 |
| Input power | Phase | 3-phase for motor power, single-phase for control power | | | |
| | Voltage | 200/200-220-230V, +10 to -15% | | | |
| | Frequency | 50/60Hz | | | |
| Control system | Sinusoidal PWM current control (full digital) | | | | |
| Carrier frequency [kHz] | 10 | | | | |
| Feedback | 16-bit serial encoder (resolution/revolution 16-bit, multi-revolution 16-bit) | | | | |
| Speed variation | ±1 [r/min] max.: load deviation 0 to 100% | | | | |
| | ±1 [r/min] max.: power fluctuation -10 to +10% | | | | |
| | ±2% max.: temperature variation 25°C±10°C at rated speed (by analog voltage input) | | | | |
| Speed control accuracy | 1:5000 (at rated load) | | | | |
| Frequency response | 600Hz [Moment of load inertia converted into motor shaft (JL)= Moment of motor inertia (JM): 100% load] | | | | |
| Max. moment of load inertia | 100 times of the motor rotor inertia (velocity control type) | | | | |
| Overload capability | 300% for 3 sec | | 300% for 3 sec, 450% for 1.5 sec | | |
| Additional functions | Braking | Regenerative braking, dynamic braking with external braking resistor | | | |
| | Protection | overcurrent (OC), overspeed (OS), low voltage (Lv), high voltage (Hv), encoder trouble (Et), control power trouble (Ct), data or memory error (dE), combination error (CE), regenerative transistor overheat (rH2), encoder communication error (EC), control signal error (CtE), motor overload (OL), regenerative resistor overheat (rH), excessive deviation (OF), amplifier overheat (AH), encoder overheat (EH), absolute data lost (AL), absolute data overflow (AF) | | | |
| | Display, setting | CHARGE lamp (red), 5-digit 7-segment LED, and 4 operation keys | | | |
| Working conditions | Installation place | For indoor use at max altitude of 1000 m. The installation place shall be free from dust, corrosive gas, or direct sunlight. To meet the European standard: Pollution degree = 2, Overvoltage category = | | | |
| | Temp., humidity | -10 to +55°C, 10 to 90% RH (without condensation) | | | |
| | Vibration, shock | 4.9m/s ² , 19.6m/s ² | | | |
| Others | DC reactor terminals (P1, P+) for suppressing harmonics The amplifier complies with UL508c (UL/cUL) and EN50178 (European standard). | | | | |
| Mass [kg] | 0.9 | | | 1.2 | 1.5 |

| Amplifier type | RYS102S3-□□S | RYS152S3-□□S | RYS202S3-□□S | RYS302S3-□□S | RYS402S3-□□S | RYS502S3-□□S |
|------------------------------|---|--|--------------|----------------|--------------|--------------|
| Applicable motor output [kW] | 1.0 | 1.5 | 2.0 | 3.0 | 4.0 | 5.0 |
| Input | Phase | 3-phase for motor power, single-phase for control power | | | | |
| | Voltage | 200/200-220-230V, +10 to -15% | | | | |
| | Frequency | 50/60Hz | | | | |
| Control system | Sinusoidal PWM current control (full digital) | | | | | |
| Carrier frequency [kHz] | 10 | 5 | | | | |
| Feedback | 16-bit serial encoder (resolution/revolution 16-bit, multi-revolution 16-bit) | | | | | |
| Speed variation | ±1 [r/min] max.: load deviation 0 to 100% | | | | | |
| | ±1 [r/min] max.: power fluctuation -10 to +10% | | | | | |
| | ±2% max.: temperature variation 25°C±10°C at rated speed (by analog voltage input) | | | | | |
| Speed control accuracy | 1:5000 (at rated load) | | | | | |
| Frequency response | 600Hz [Moment of load inertia converted into motor shaft (JL)= Moment of motor inertia (JM): 100% load] | | | | | |
| Max. moment of load inertia | 100 times of the motor rotor inertia (velocity control type) | | | | | |
| Overload capability | 300% for 3 sec, 400% for 1.5 sec | | | 300% for 3 sec | | |
| Additional functions | Braking | Regenerative braking, dynamic braking with external braking resistor | | | | |
| | Protection | overcurrent (OC), overspeed (OS), low voltage (Lv), high voltage (Hv), encoder trouble (Et), control power trouble (Ct), data or memory error (dE), combination error (CE), regenerative transistor overheat (rH2), encoder communication error (EC), control signal error (CtE), motor overload (OL), regenerative resistor overheat (rH), excessive deviation (OF), amplifier overheat (AH), encoder overheat (EH), absolute data lost (AL), absolute data overflow (AF), fuse blown (Fb): 2kW or over | | | | |
| | Display, setting | CHARGE lamp (red), 5-digit 7-segment LED, and 4 operation keys | | | | |
| Working conditions | Installation place | For indoor use at max altitude of 1000 m. The installation place shall be free from dust, corrosive gas, or direct sunlight. To meet the European standard: Pollution degree = 2, Overvoltage category = | | | | |
| | Temp., humidity | -10 to +55°C, 10 to 90% RH (without condensation) | | | | |
| | Vibration / shock | 4.9m/s ² , 19.6m/s ² | | | | |
| Others | DC reactor terminals (P1, P+) for suppressing harmonics The amplifier complies with UL508c (UL/cUL) and EN50178 (European standard). | | | | | |
| Mass [kg] | 2.0 | | 4.6 | 4.7 | 5.2 | 5.2 |

*1: The applied motor output shows capacity output by the standard combination.

*2: The overload capacities 450% and 400% apply to the one-rank lower motors (the above amplifier is not usable for the 0.1kW slim type motor).

SPECIFICATIONS

SERVO AMPLIFIER (Single-phase 100V Series)

Basic type

| Amplifier type | RYS500S3-VVS6 | | RYS101S3-VVS6 | | RYS201S3-VVS6 | |
|------------------------------|---|--|---------------|--|---------------|--|
| Applicable motor output [kW] | 0.05 | | 0.1 | | 0.2 | |
| Input | Phase | Single-phase for motor power, single-phase for control power | | | | |
| | Voltage | 100 to 115V -15% to 10% | | | | |
| | Frequency | 50/60Hz | | | | |
| Control system | Sinusoidal PWM current control (full digital) | | | | | |
| Carrier frequency [kHz] | 10 | | | | | |
| Feedback | 16-bit serial encoder (resolution/revolution 16-bit, multi-revolution 16-bit) | | | | | |
| Speed variation | ±1 [r/min] max.: load deviation 0 to 100% | | | | | |
| | ±1 [r/min] max.: power fluctuation -10 to +10% | | | | | |
| | ±2% max.: temperature variation 25°C±10°C at rated speed (by analog voltage input) | | | | | |
| Speed control accuracy | 1:5000 (at rated load) | | | | | |
| Frequency response | 600Hz [Moment of load inertia converted into motor shaft (JL)= Moment of motor inertia (JM)] | | | | | |
| Max. moment of load inertia | 100 times of the motor rotor inertia (velocity control type) | | | | | |
| Overload capability | 300% for 3 sec | | | | | |
| Additional functions | Braking (*) | Regenerative braking, dynamic braking with external braking resistor | | | | |
| | Protection | overcurrent (OC), overspeed (OS), low voltage (Lv), high voltage (Hv), encoder trouble (Et), control power trouble (Ct), data or memory error (dE), combination error (CE), regenerative transistor overheat (RH2), encoder communication error (EC), control signal error (CIE), motor overload (OL), regenerative resistor overheat (RH), excessive deviation (OF), amplifier overheat (AH), encoder overheat (EH), absolute data lost (AL), absolute data overflow (AF) | | | | |
| | Display, setting | CHARGE lamp (red), 5-digit 7-segment LED, and 4 operation keys | | | | |
| Working conditions | Installation place | For indoor use at max altitude of 1000 m. The installation place shall be free from dust, corrosive gas, or direct sunlight. To meet the European standard: Pollution degree = 2, Overvoltage category = II | | | | |
| | Temp., humidity | -10 to +55°C, 10 to 90% RH (without condensation) | | | | |
| | Vibration, shock | 4.9m/s ² , 19.6m/s ² | | | | |
| Others | DC reactor terminals (P1, P+) for suppressing harmonics, The amplifier complies with UL508c (UL/cUL) and EN50178 (European standard). | | | | | |
| Mass [kg] | 0.9 | | | | 1.2 | |

*1: The 0.2kW amplifier incorporates a DB resistor.

Standard type for V type amplifier

| Amplifier type | RYS□□□S3-VVS | Terminal symbol |
|----------------------------------|---|---|
| Pulse train input | Max. input frequency: 500kHz (at differential input) | CA, *CA |
| Pulse train form | (1) Command pulse/code (2) Forward/reverse rotation pulse (3) Two 90° phase-different signals | CB, *CB |
| Frequency dividing output | Max. output frequency: 500kHz (at differential output) | FA, *FA |
| Freq. dividing output form | Two 90° phase-different signals | FB, *FB |
| Frequency dividing output pulses | 16 to 16384 pulses/rev. (in increment of 1 pulse) | FZ, *FZ |
| Power source for speed command | +10±0.4V (max. output current: 30mA) | P10 |
| Speed command input | ±10V (input impedance: 20 kΩ) | NREF |
| Torque command input | ±10V (input impedance: 20 kΩ) | TREF |
| Monitor output 1/2 | For analog-meter (two-way/one-way deflection) (1) Speed command (2) Speed feedback (3) Torque command (4) Positional deviation | MON1 MON2 |
| Power source for I/F | +24V DC, 300mA (supplied from external power source) | P24, M24 |
| Control input | +24V DC, 10mA (one-point) source input Terminals to which control input signals are assigned | CONT1 to CONT8 |
| OUT output | +30V DC, 50mA (max.) sink output Terminals to which control output signals are assigned | OUT1 to OUT5 |
| External backup | Input terminal used to supply encoder backup power from external power source | BAT+, BAT- |
| Control functions | Control form | Position, speed, and torque control (selectable with control input signals) |
| | Position control | Pulse train, interruptive positioning, return to origin |
| | Origin setting | Origin limit switches, zero phase, and position preset |
| | Speed control | Analog voltage, multistep speed setting |
| | Torque control | Analog voltage |
| | Other functions | Override, brake timing output, etc. |

Standard type for L type amplifier

| Amplifier type | RYS□□□S3-LPS | Terminal symbol |
|----------------------------------|---|---|
| Pulse train input | Max. input frequency: 500kHz (at differential input) | CA, *CA |
| Pulse train form | (1) Command pulse/code (2) Forward/reverse rotation pulse (3) Two 90° phase-different signals | CB, *CB |
| Frequency dividing output | Max. output frequency: 500kHz (at differential output) | FA, *FA |
| Freq. dividing output form | Two 90° phase-different signals | FB, *FB |
| Frequency dividing output pulses | 16 to 16384 pulses/rev. (in increment of 1 pulse) | FZ, *FZ |
| Power source for speed command | +10±0.4V (max. output current: 30mA) | P10 |
| Speed command input | ±10V (input impedance: 20 kΩ) | NREF |
| Monitor output 1/2 | For analog-meter (two-way/one-way deflection) (1) Speed command (2) Speed feedback (3) Torque command (4) Positional deviation | MON1 MON2 |
| Power source for I/F | +24V DC, 300mA (supplied from external power source) | P24, M24 |
| Control input | +24V DC, 10mA (one-point) source input Terminals to which control input signals are assigned | CONT1 to CONT21 |
| OUT output | +30V DC, 50mA (max.) sink output Terminals to which control output signals are assigned | OUT1 to OUT10 |
| External backup | Input terminal used to supply encoder backup power from external power source | BAT+, BAT- |
| Control functions | Position control | Auto start (address designation, sequential start, immediate positioning) Manual operation (analog voltage, multistep speed setting, interruptive positioning) Pulse train input, return to origin (4 patterns) |
| | Origin setting | Origin limit switches, zero phase, and position preset |
| | No. of position data sets | 99 points (position, speed, timer, M code and various statuses) |
| | Max positioning value | ±79,999,999 (x unit amount) |
| | Additional functions | Override, brake timing output, etc. |

Standard type for R type amplifier

| Amplifier type | RYS□□□S3-RPS | Terminal symbol |
|----------------------------------|---|--|
| Pulse train input | Max. input frequency: 500kHz (at differential input) | CA, *CA |
| Pulse train form | (1) Command pulse/code (2) Forward/reverse rotation pulse (3) Two 90° phase-different signals | CB, *CB |
| Frequency dividing output | Max. output frequency: 500kHz (at differential output) | FA, *FA |
| Freq. dividing output form | Two 90° phase-different signals | FB, *FB |
| Frequency dividing output pulses | 16 to 16384 pulses/rev. (in increment of 1 pulse) | FZ, *FZ |
| Power source for speed command | +10±0.4V (max. output current: 30mA) | P10 |
| Speed command input | ±10V (input impedance: 20 kΩ) | NREF |
| Monitor output 1/2 | For analog-meter (two-way/one-way deflection) (1) Speed command (2) Speed feedback (3) Torque command (4) Positional deviation | MON1 MON2 |
| Power source for I/F | +24V DC, 300mA (supplied from external power source) | P24, M24 |
| Control input | +24V DC, 10mA (one-point) source input Terminals to which control input signals are assigned | CONT1 to CONT21 |
| OUT output | +30V DC, 50mA (max.) sink output Terminals to which control output signals are assigned | OUT1 to OUT10 |
| External backup | Input terminal used to supply encoder backup power from external power source | BAT+, BAT- |
| Control functions | Position control | Auto start (station designation), Manual operation (analog voltage, multistep speed setting, manual indexing), Pulse train input, return to origin |
| | Origin setting | Origin limit switches, zero phase, and position preset |
| | No. of divisions | 30000 |
| | Speed reduction ratio | α/β (α=1 to 9999, β=1 to 9999 in increments of 1) |
| | Additional functions | Override, brake timing output, 2nd origin effective, etc. |

SERVO AMPLIFIER

■ For amplifier directly connected to SX bus

| Amplifier type | RYS□□□S3-□SS | Terminal symbol |
|----------------------------------|---|-----------------|
| SX bus | IQ area, 16 words | (IN, OUT) |
| Pulse train input | (*1) Max. input frequency: 500kHz (at differential input) | CA, *CA |
| Pulse train form | (*1) (1) Command pulse/code (2) Forward/reverse rotation pulse (3) Two 90° phase-different signals | CB, *CB |
| Power source for pulse train | 5 V DC, 200mA (max.) | P5 |
| Frequency dividing output | Max. output frequency: 500kHz (at differential output) | FA, *FA |
| Freq. dividing form | Two 90° phase-different signals | FB, *FB |
| Frequency dividing output pulses | 16 to 16384 pulses/rev. (in increment of 1 pulse) | FZ, *FZ |
| Power source for speed command | --- | --- |
| Speed command input | --- | --- |
| Torque command input | --- | --- |
| Monitor output 1/2 | For analog-meter (two-way/one-way deflection). (1) Speed command (2) Speed feedback (3) Torque command (4) Positional deviation | MON1 MON2 |
| Power source for I/F | +24V DC, 300mA (supplied from external power source) | P24, M24 |
| Control input | +24V DC, 10mA (one-point) source input External control input terminals | CONT1 to CONT5 |
| OUT output | +30V DC, 50mA (max.) sink output External control output terminals | OUT1 and OUT2 |
| External backup | Input terminals used to supply encoder backup power from external power source | BAT+ BAT- |
| Control functions | V type: Depends on MICREX-SX FB L type: Same with DI/DO specifications (RYS-LPS) R type: Same with DI/DO specifications (RYS-RPS) | |

*1: type does not have a pulse train input terminal.

■ For amplifier directly connected to T-link

| Amplifier type | RYS□□□S3-□TS | Terminal symbol |
|----------------------------------|--|-----------------|
| T link | B area, 8 words | (T2, T1, SD) |
| Pulse train input | Max. input frequency: 500kHz (at differential input) | CA, *CA |
| Pulse train form | (1) Command pulse/code (2) Forward/reverse rotation pulse (3) Two 90° phase-different signals | CB, *CB |
| Power source for pulse train | 5 V DC, 200mA (max.) | P5 |
| Frequency dividing output | Max. output frequency: 200kHz (open collector) | |
| Freq. dividing form | Two 90° phase-different signals | FA, FB, FZ |
| Frequency dividing output pulses | 16 to 16384 pulses/rev. (in increment of 1 pulse) | |
| Power source for speed command | --- | --- |
| Speed command input | --- | --- |
| Monitor output 2 | For analog-meter (two-way/one-way deflection). (1) Speed command (2) Speed feedback (3) Torque command (4) Positional deviation | MON2 |
| Power source for I/F | +24V DC, 100mA (supplied from external power source) | P24, M24 |
| Control input | +24V DC, 10mA (one-point) source input External control input terminals | CONT1 to CONT8 |
| OUT output | +30V DC, 50mA (max.) sink output External control output terminals | OUT1 to OUT4 |
| External backup | Input terminals used to supply encoder backup power from external power source | BAT+ |
| Control functions | L type: Same with DI/DO specifications (RYS-LPS) R type: Same with DI/DO specifications (RYS-RPS) | |

■ For amplifier directly connected to RS485

| Amplifier type | RYS□□□S3-□RS | Terminal symbol |
|----------------------------------|--|-----------------|
| RS485 | 4-wire, half duplex system (max. 31 stations) | --- |
| Pulse train input | Max. input frequency: 500kHz (at differential input) | CA, *CA |
| Pulse train form | (1) Command pulse/code (2) Forward/reverse rotation pulse (3) Two 90° phase-different signals | CB, *CB |
| Power source for pulse train | 5 V DC, 200mA (max.) | P5 |
| Frequency dividing output | Max. output frequency: 200kHz (open collector) | |
| Freq. dividing form | Two 90° phase-different signals | FA, FB, FZ |
| Frequency dividing output pulses | 16 to 16384 pulses/rev. (in increment of 1 pulse) | |
| Power source for speed command | --- | --- |
| Speed command input | --- | --- |
| Torque command input | --- | --- |
| Monitor output 2 | For analog-meter (two-way/one-way deflection). (1) Speed command (2) Speed feedback (3) Torque command (4) Positional deviation | MON2 |
| Power source for I/F | +24V DC, 100mA (supplied from external power source) | P24, M24 |
| Control input | +24V DC, 10mA (one-point) source input External control input terminals | CONT1 to CONT8 |
| OUT output | +30V DC, 50mA (max.) sink output External control output terminals | OUT1 to OUT4 |
| External backup | Input terminals used to supply encoder backup power from external power source | BAT+ |
| Control functions | L type: Same with DI/DO specifications (RYS-LPS) | |

3-phase 200V series

[V type] Standard

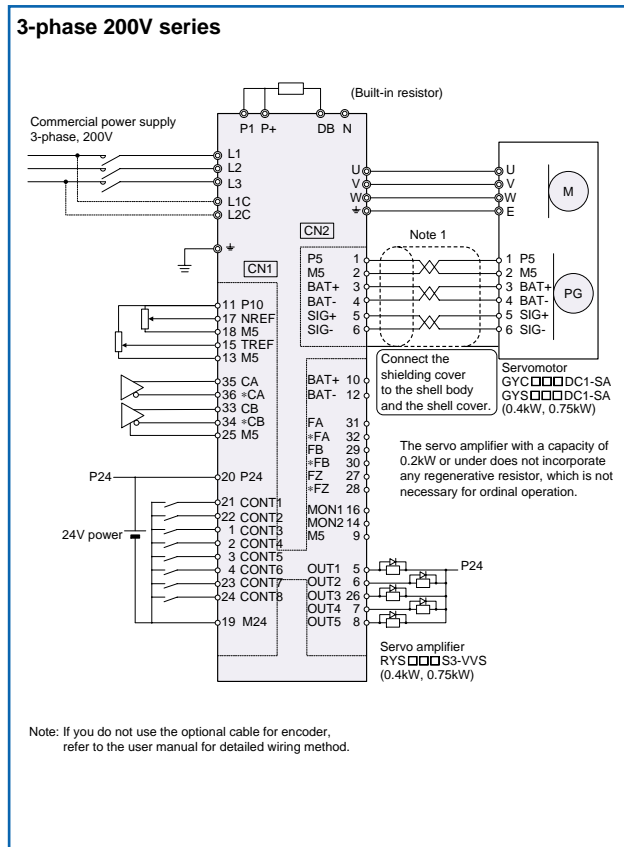

[L, R type] Standard

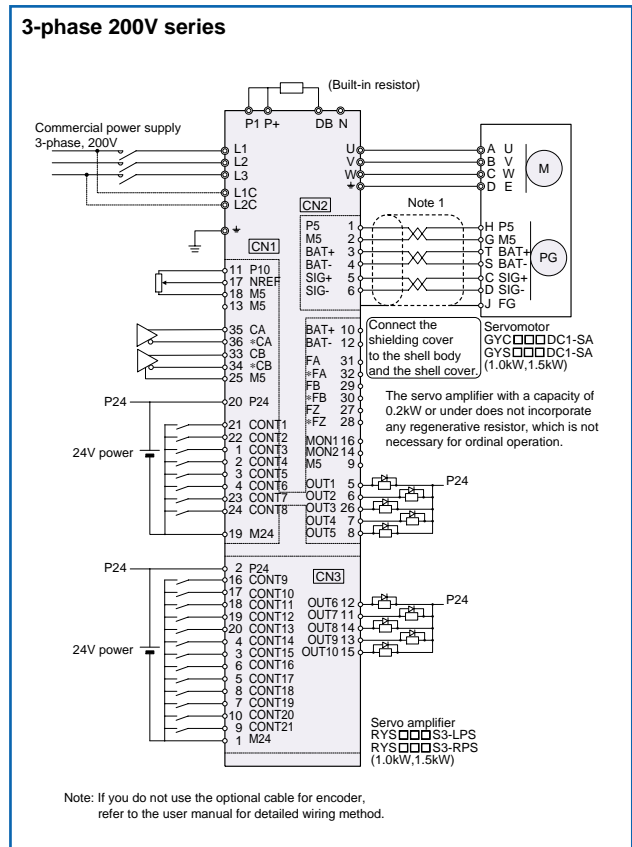

[V type] Direct connection with SX bus

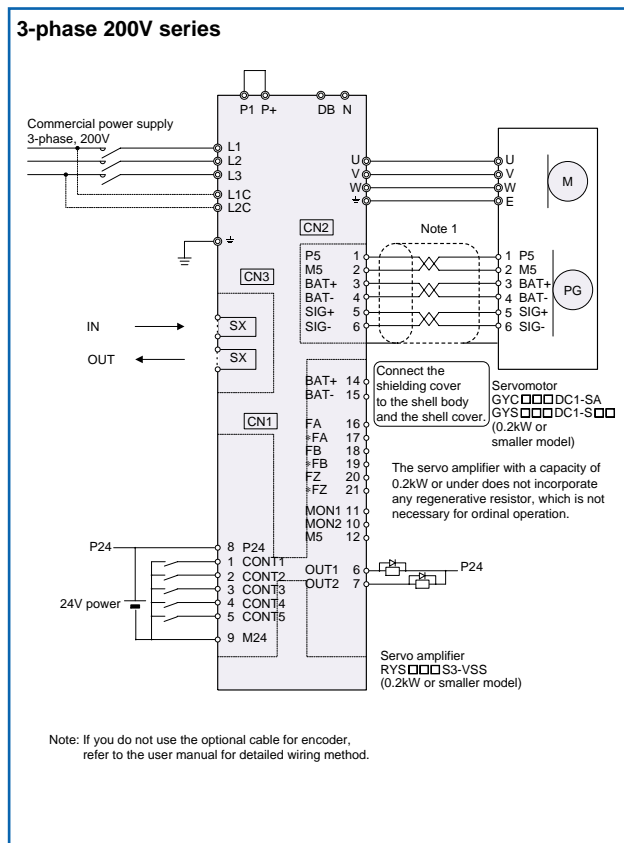

[L, R type] Direct connection with SX bus

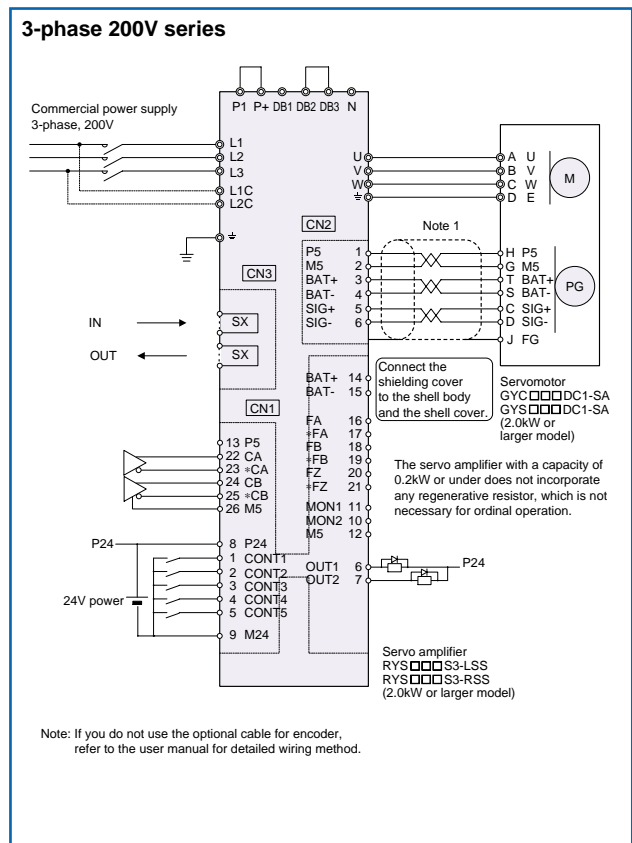

3-phase 200V, Single-phase 100V series

[L, R type]Direct connection with T-link

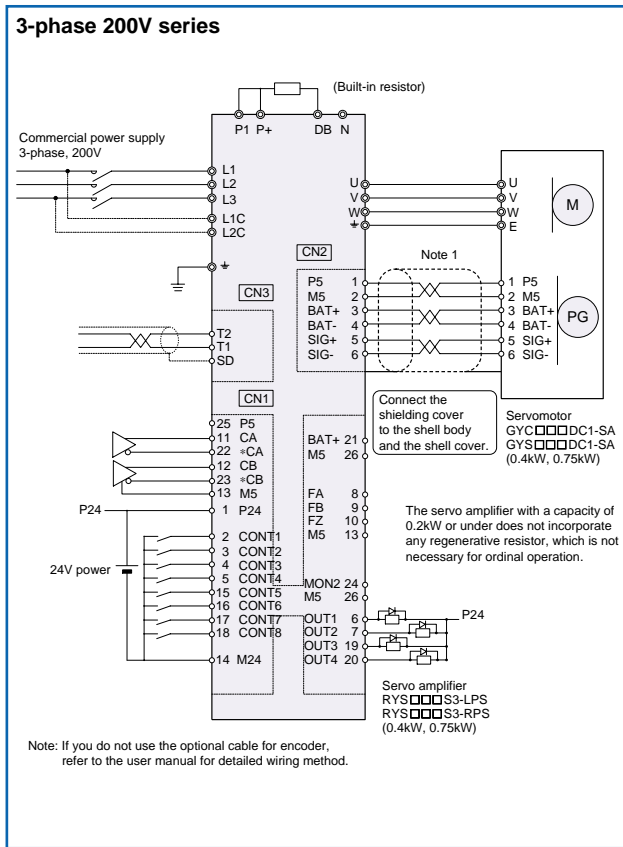

[L, R type]Direct connection with RS485

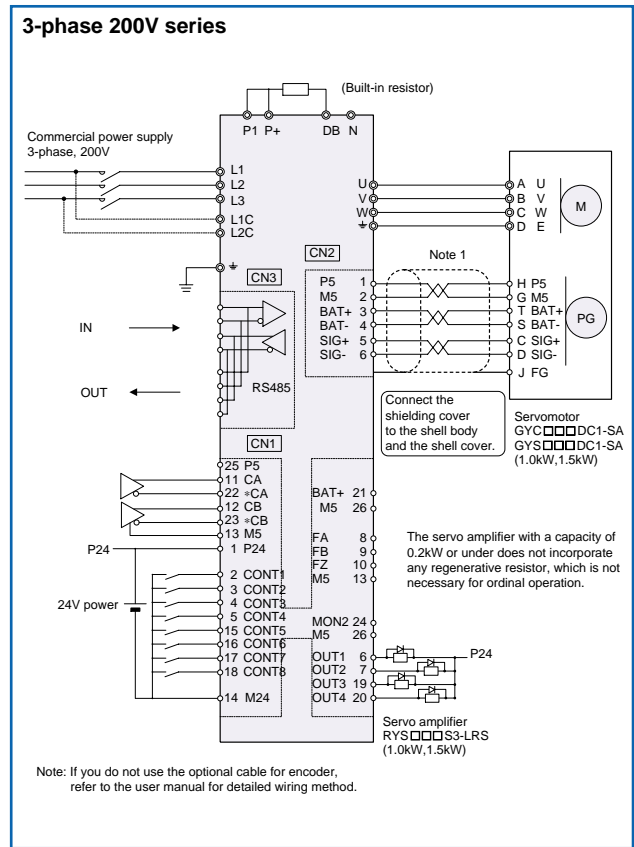

[V type]DI/DO

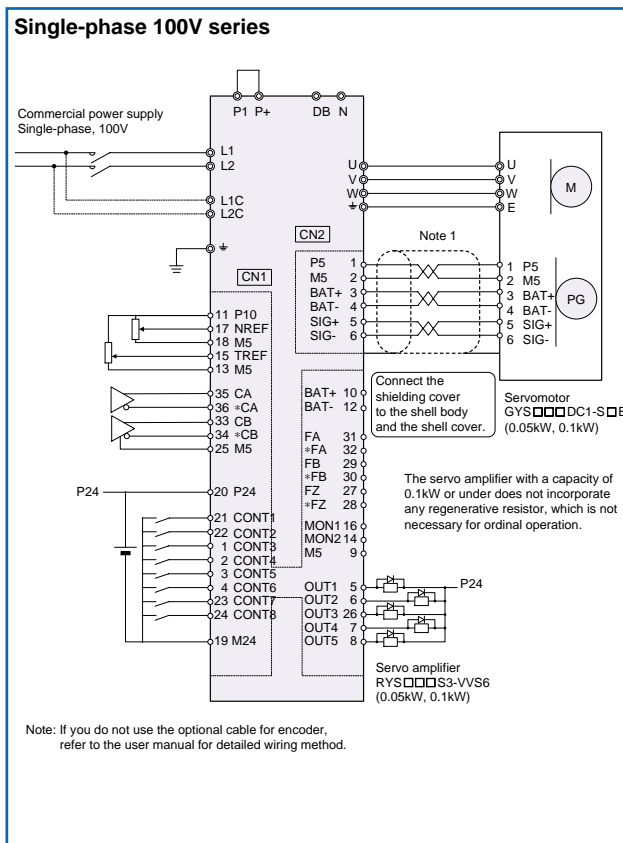

CAUTION

The above diagram is given as a reference for model selection. When actually using the selected servo system, make wiring connections according to the connection diagram and instructions described in the user's manual.

EXTERNAL DIMENSIONS

200V series

[Cubic type]

Series: GYC series motor of standard type

Type: GYC101DC1-SA to GYC202DC1-SA

Capacity range: 0.1 to 2.0kW

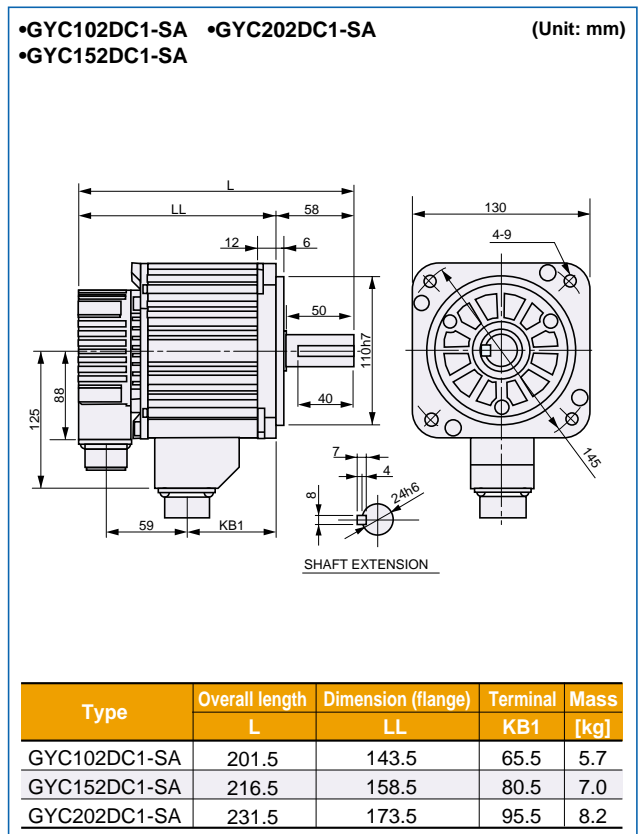
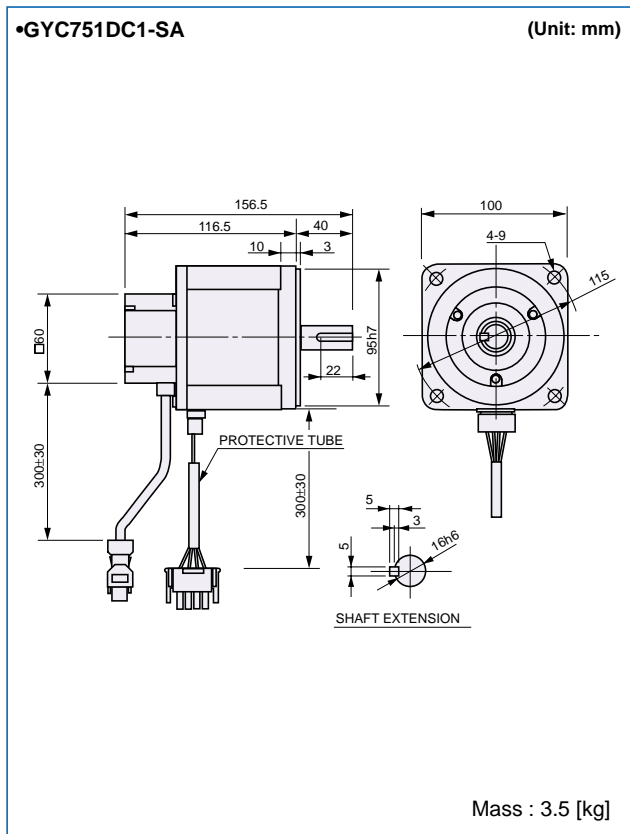
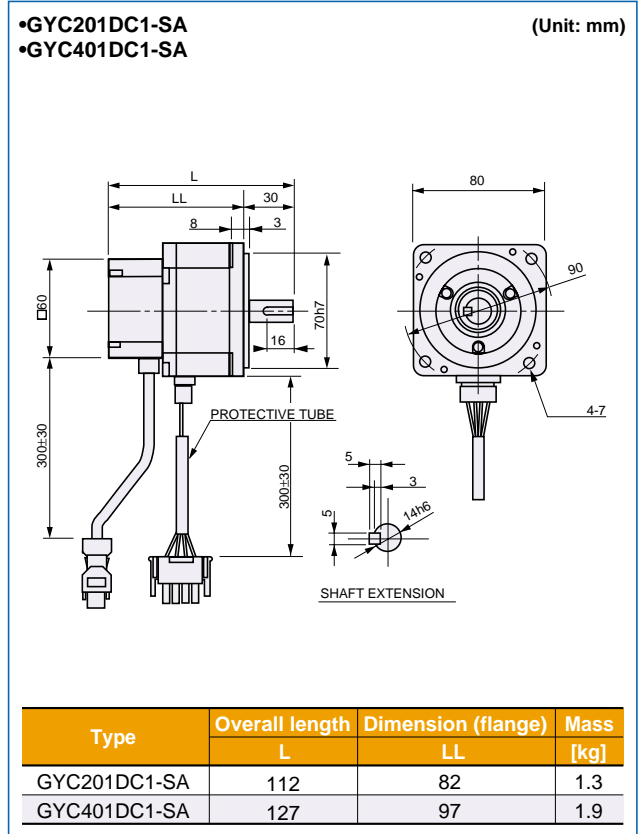
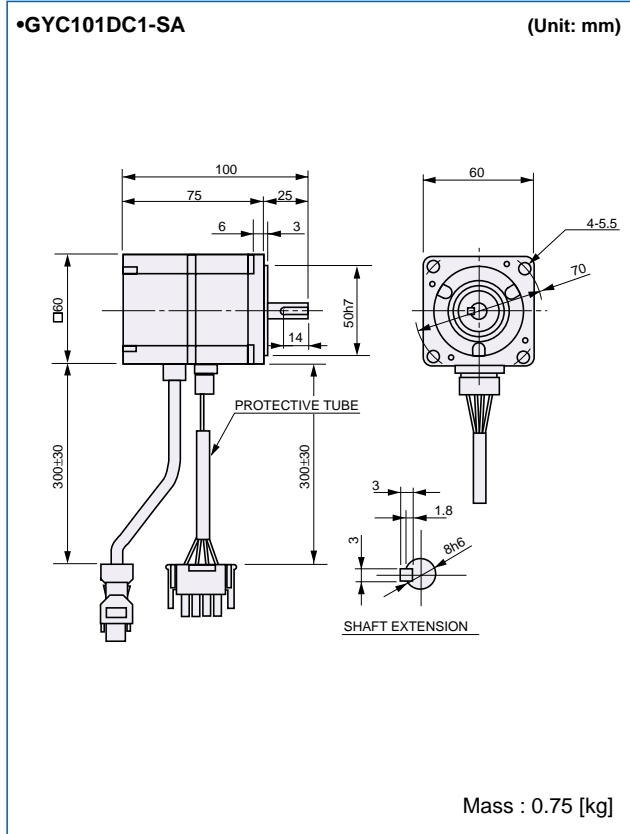

[Cubic type]

Series: GYC series motor with a brake

Type: GYC101DC1-SA-B to GYC202DC1-SA-B

Capacity range: 0.1 to 2.0kW

•GYC101DC1-SA-B (Unit: mm)

Mass : 1.0 [kg]

•GYC201DC1-SA-B
•GYC401DC1-SA-B (Unit: mm)

| Type | Overall length | Dimension (flange) | Mass [kg] |
|----------------|----------------|--------------------|-----------|
| | L | LL | |
| GYC201DC1-SA-B | 143.5 | 113.5 | 1.9 |
| GYC401DC1-SA-B | 158.5 | 128.5 | 2.6 |

•GYC751DC1-SA-B (Unit: mm)

Mass : 4.3 [kg]

•GYC102DC1-SA-B •GYC202DC1-SA-B
•GYC152DC1-SA-B (Unit: mm)

| Type | Overall length | Dimension (flange) | Terminal | Mass [kg] |
|----------------|----------------|--------------------|----------|-----------|
| | L | LL | KB1 | |
| GYC102DC1-SA-B | 243.5 | 185.5 | 67.5 | 8.0 |
| GYC152DC1-SA-B | 258.5 | 200.5 | 82.5 | 9.8 |
| GYC202DC1-SA-B | 273.5 | 215.5 | 97.5 | 11.0 |

EXTERNAL DIMENSIONS

200V / 100V series

[Slim type]

Series: GYS series motor of standard type

Type: GYS500DC1-S8B to GYS502DC1-SA

Capacity range: 0.05 to 5.0kW

- GYS500DC1-S8B (200V / 100V series)
- GYS101DC1-SB (200V series) •GYS101DC1-S6B (100V series)

(Unit: mm)

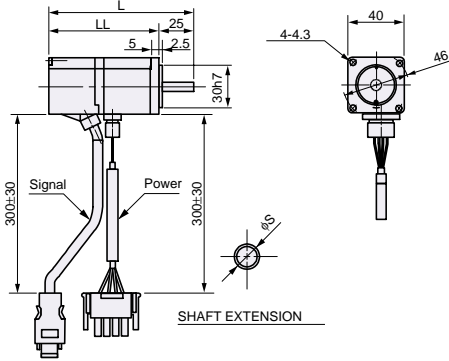

| Type | Shaft end shape φS | Overall length L | Dimension (flange) LL | Mass [kg] |
|----------------|-----------------------|---------------------|--------------------------|--------------|
| GYS500DC1-S8B* | 6h6 | 103 | 78 | 0.45 |
| GYS101DC1-SB | 8h6 | 121 | 96 | 0.55 |
| GYS101DC1-S6B | 8h6 | 121 | 96 | 0.55 |

*100V series has the same dimensions.

Series: GYS series motor of standard type

Type: GYS500DC1-S8B to GYS201DC1-S6B

Capacity range: 0.05 to 0.2kW

- GYS201DC1-SA (200V series) •GYS201DC1-S6B (100V series)
- GYS401DC1-SA (200V series)

(Unit: mm)

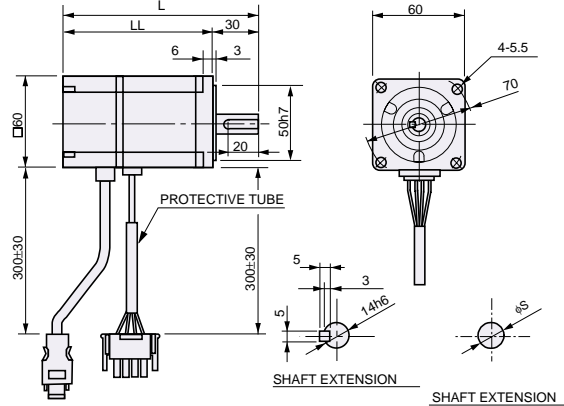

| Type | Overall length L | Dimension (flange) LL | Mass [kg] |
|---------------|---------------------|--------------------------|--------------|
| GYS201DC1-SA | 126.5 | 96.5 | 1.2 |
| GYS401DC1-SA | 154.5 | 124.5 | 1.8 |
| GYS201DC1-S6B | 126.5 | 96.5 | 1.2 |

- GYS751DC1-SA

(Unit: mm)

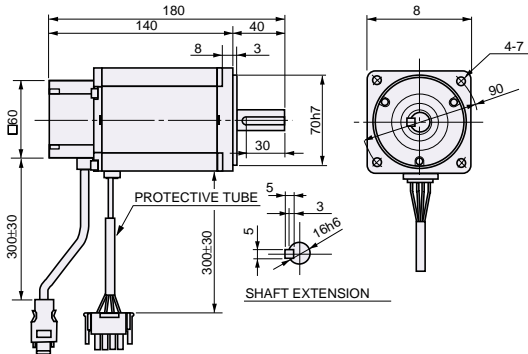

Mass : 3.4 [kg]

- GYS102DC1-SA •GYS202DC1-SA
- GYS152DC1-SA

(Unit: mm)

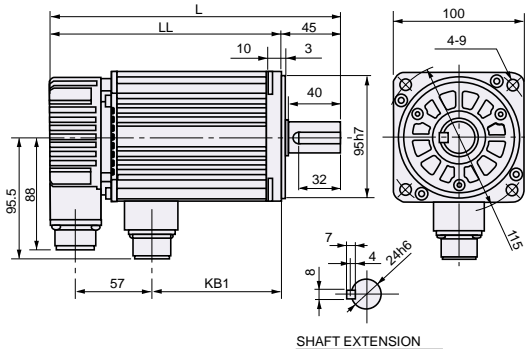

| Type | Overall length L | Dimension (flange) LL | Terminal KB1 | Mass [kg] |
|--------------|---------------------|--------------------------|-----------------|--------------|
| GYS102DC1-SA | 198 | 153 | 77 | 4.4 |
| GYS152DC1-SA | 220.5 | 175.5 | 99.5 | 5.2 |
| GYS202DC1-SA | 243 | 198 | 122 | 6.3 |

- GYS302DC1-SA •GYS502DC1-SA
- GYS402DC1-SA

(Unit: mm)

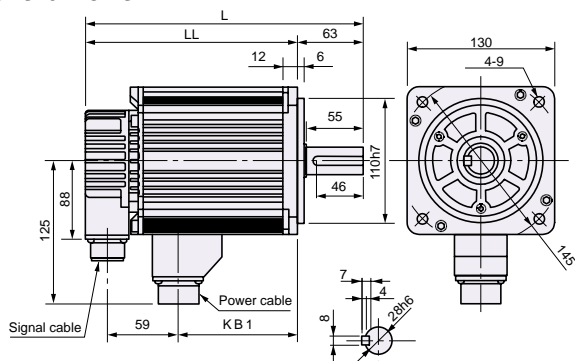

| Type | Overall length L | Dimension (flange) LL | Terminal KB1 | Mass [kg] |
|--------------|---------------------|--------------------------|-----------------|--------------|
| GYS302DC1-SA | 266.5 | 203.5 | 122.5 | 11.0 |
| GYS402DC1-SA | 296.5 | 233.5 | 155.5 | 13.5 |
| GYS502DC1-SA | 326.5 | 263.5 | 185.5 | 16.0 |

EXTERNAL DIMENSIONS

200V series

[Cubic type]

Series: Gear head for GYC series motor

Type: GYN101CAG-G09 to GYN202CAG-G09

Capacity range: 0.1 to 2.0kW

Series: Gear head for GYC series motor

Type: GYN101CAG-G25 to GYN202CAG-G15

* For 1.0 kW or larger capacity model, the reduction ratio is 1/15.

Capacity range: 0.1 to 2.0kW

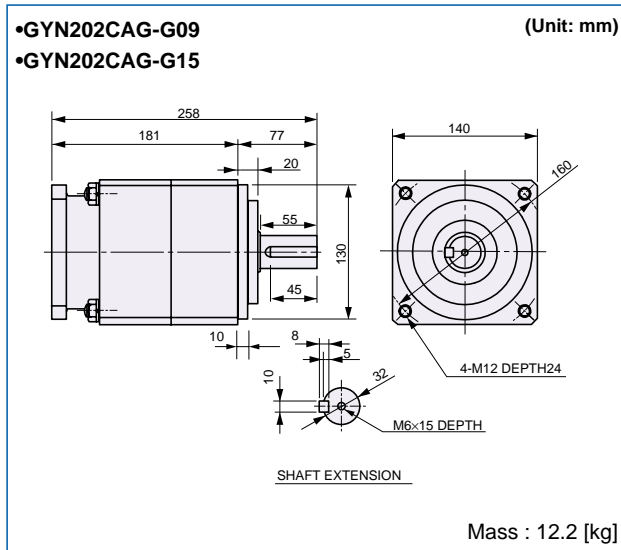
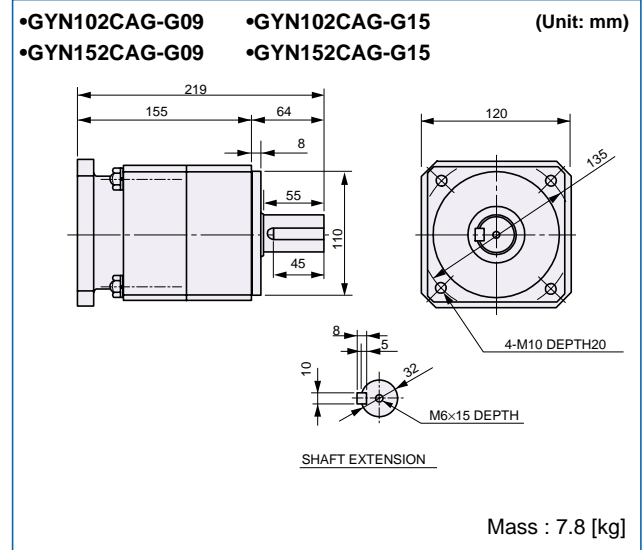
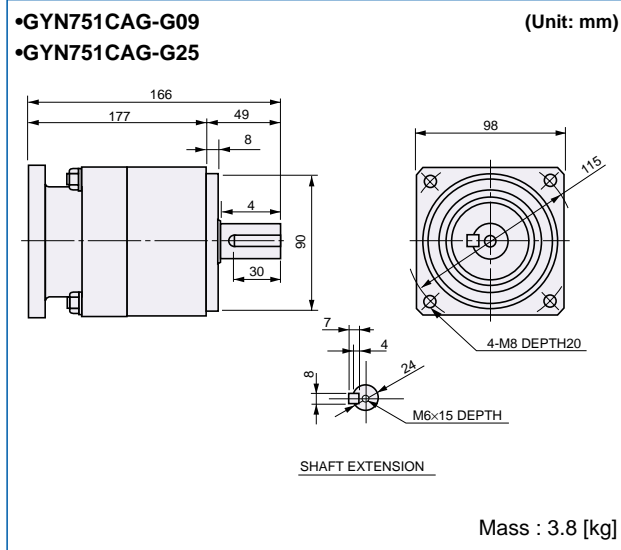
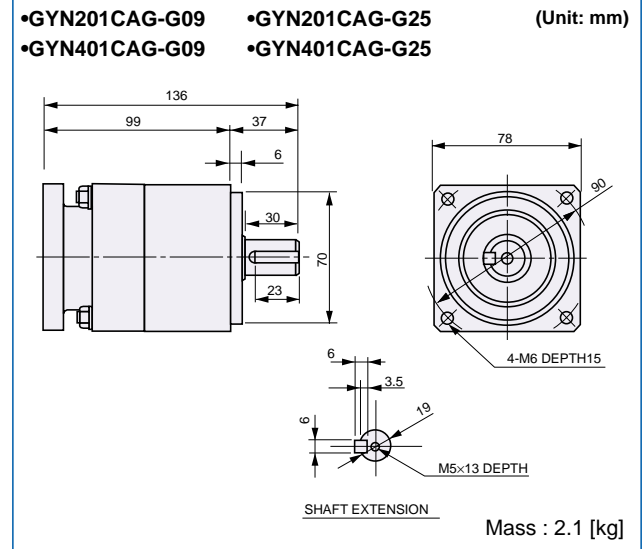
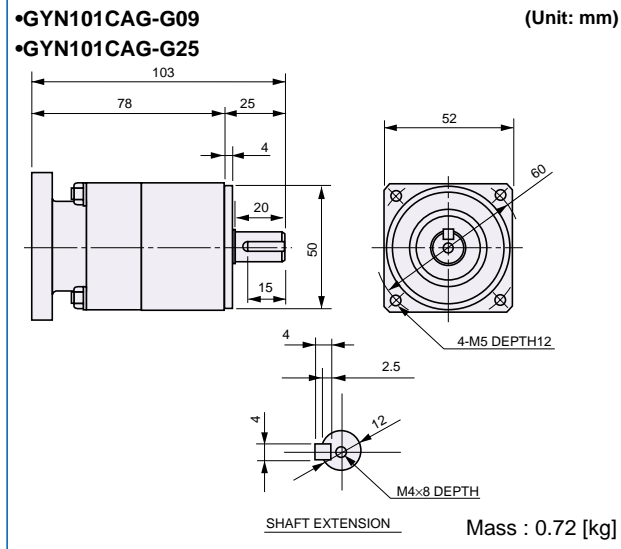

[Slim type]

Series: Gear head for GYS series motor

Type: GYN500SAG-G09 to GYN202SAG-G09

Capacity range: 0.05 to 2.0kW

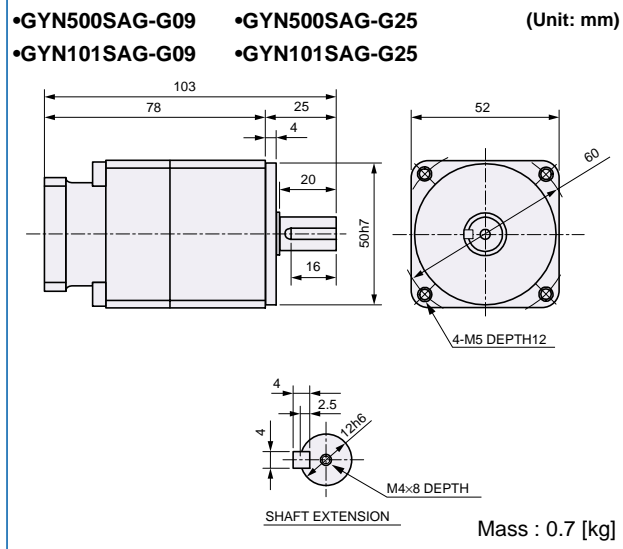

Series: Gear head for GYS series motor

Type: GYN500SAG-G25 to GYN202SAG-G15

* For 1.0 kW or larger capacity models, the reduction ratio is 1/15.

Capacity range: 0.05 to 2.0kW

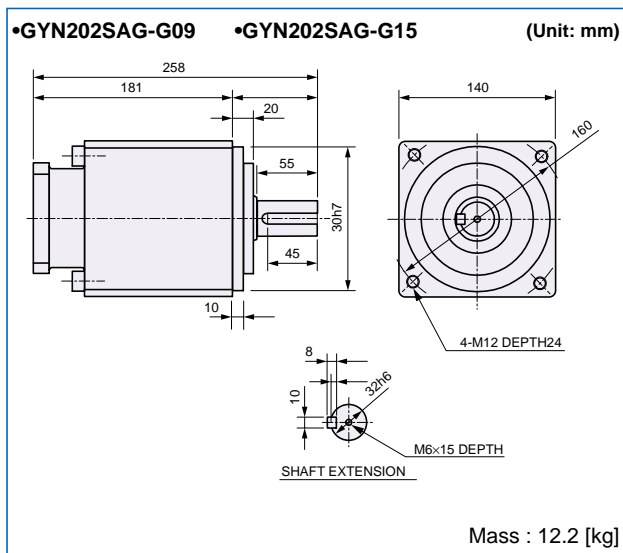
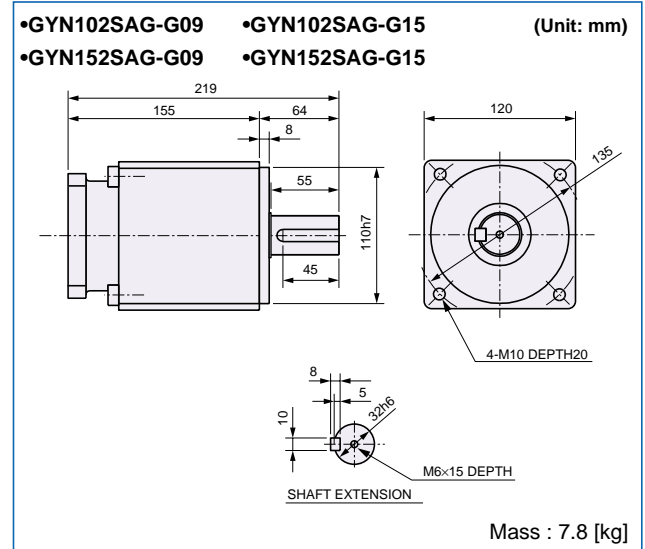
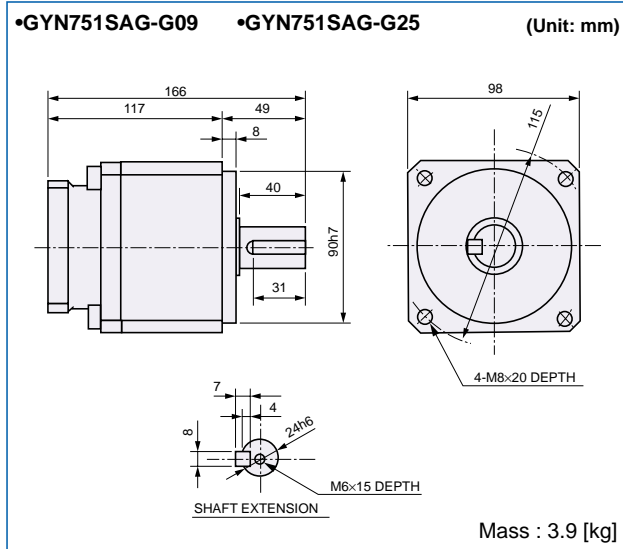
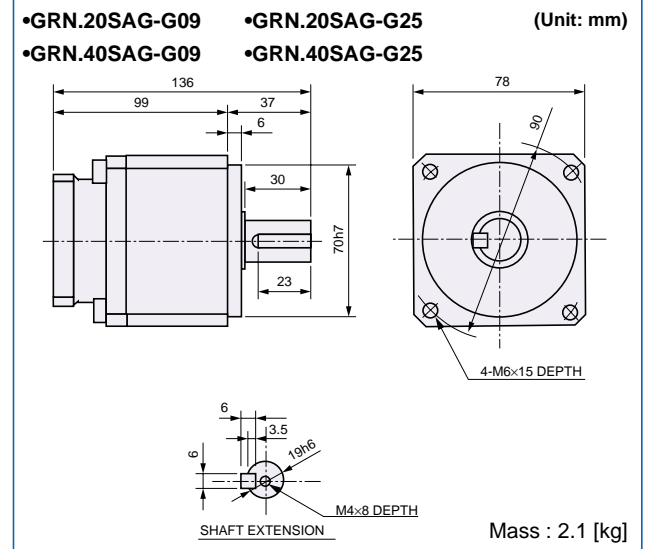

EXTERNAL DIMENSIONS

3-phase 200V, Single-phase 100V series

[Series] RYS series servo amplifier

[Type] RYS500S3-□□S to RYS152S3-□□S, (RYS500S3-VVS6 to RYS201S3-VVS6)

*Types and capacities in () are for single-phase 100V series.

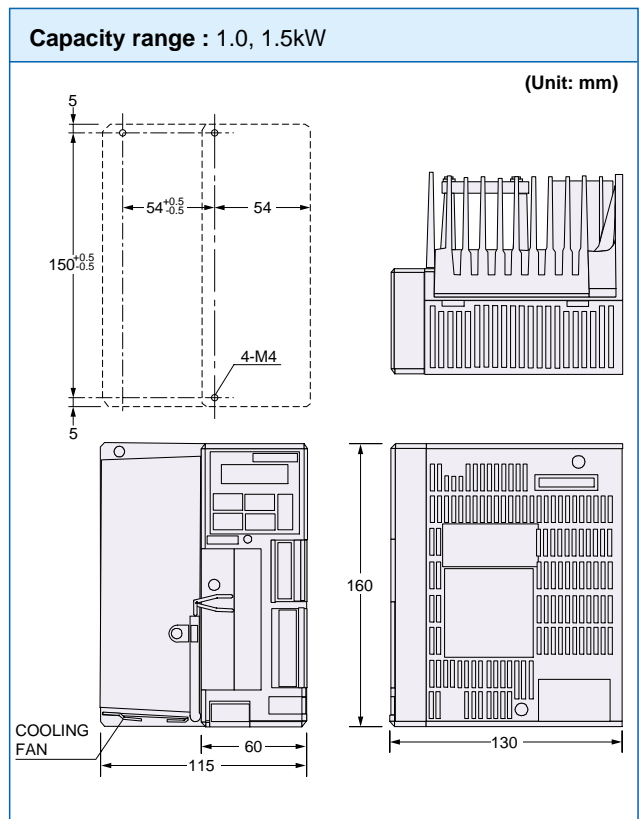
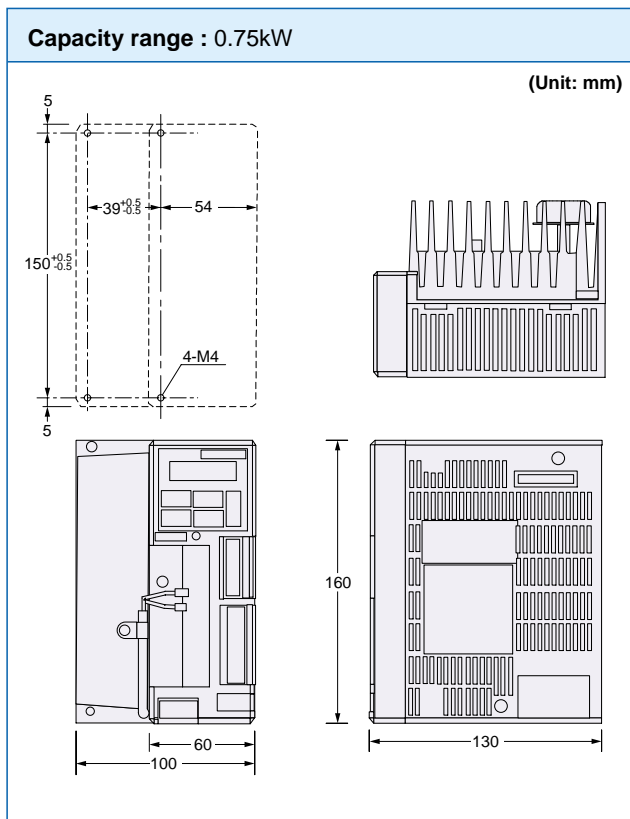
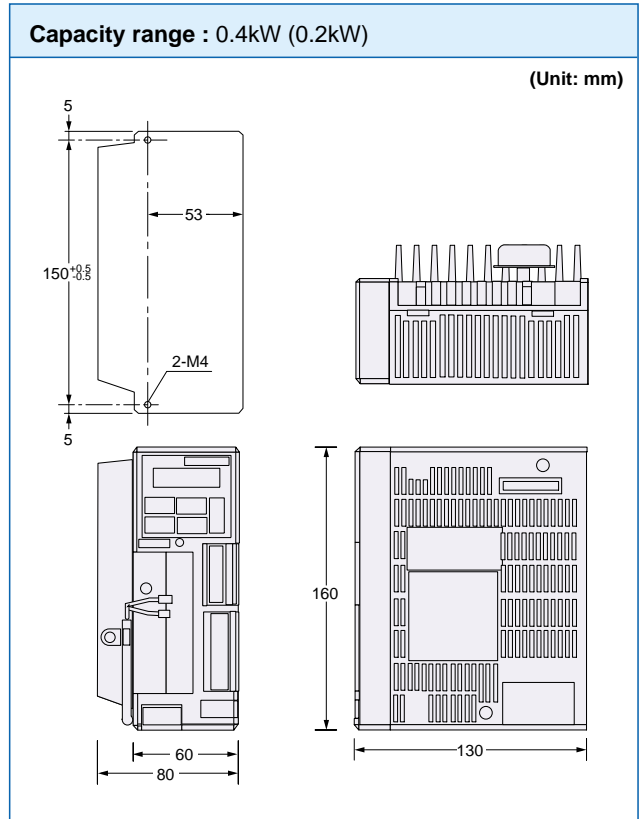
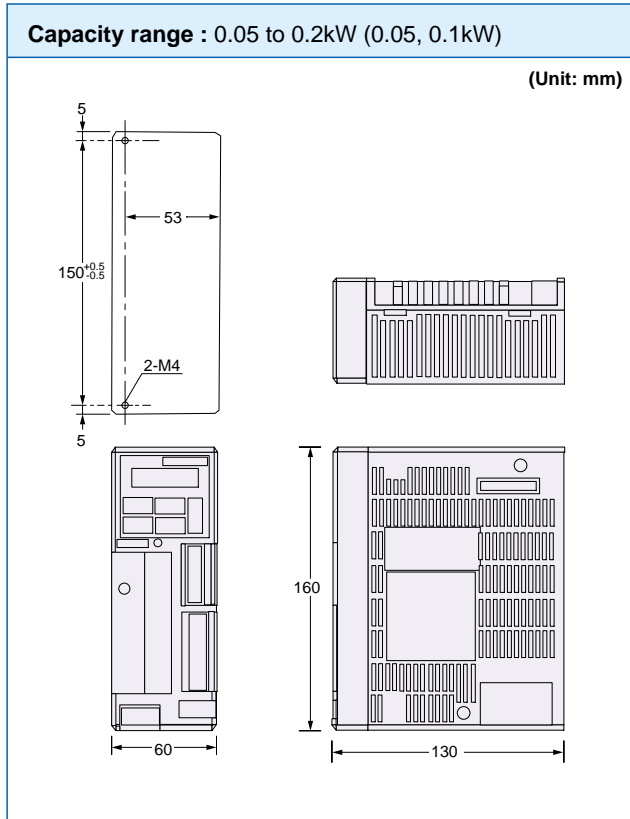

[Series] RYS series servo amplifier

[Type] RYS202S3-□□S to RYS502S3-□□S

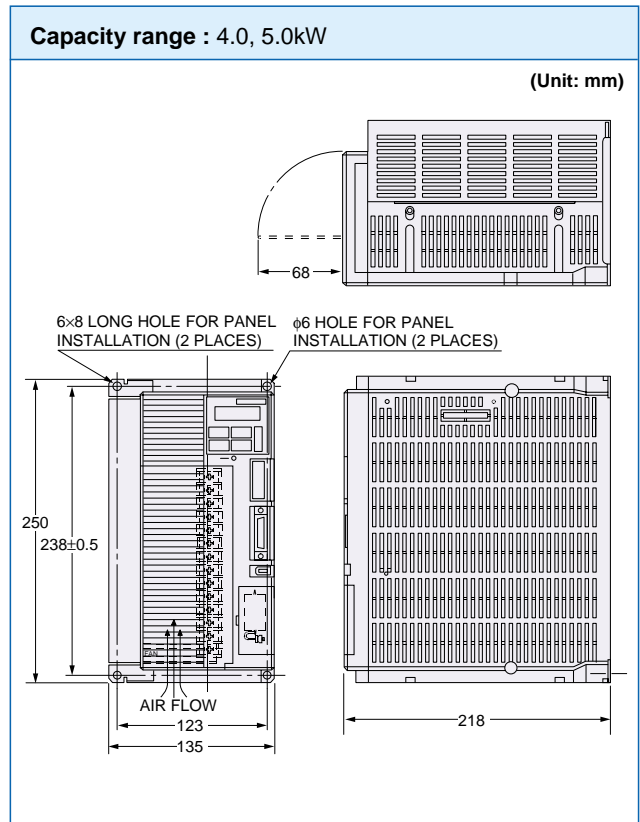
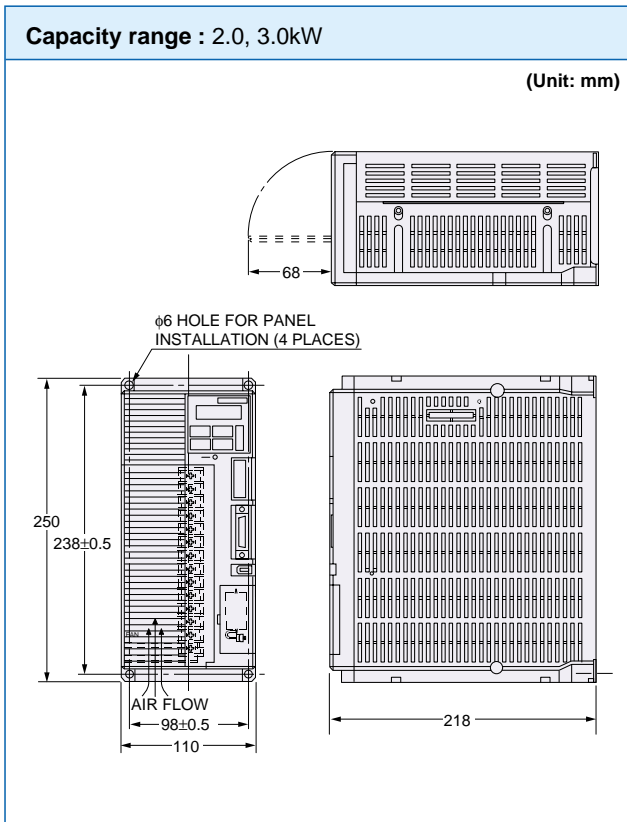

Option

Series: Cable for input/output of control signals
(extended I/O for L and R types)

Type: WSC-D20P03

Applicable amplifier: RYS□□□S3-LPS and RPS (CN3)

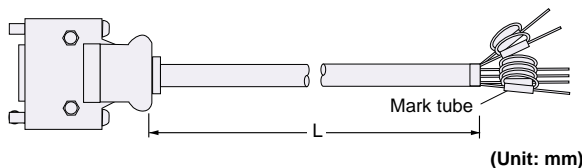

| Type | L |
|------------|-------------------------------------|
| WSC-D20P03 | 3000 ⁺³⁰⁰ / ₀ |

Series: Cable for input/output of control signals
(directly connected to SX bus)

Type: WSC-D26P03

Applicable amplifier: RYS□□□S3-VSS, LSS, and RSS (CN1)

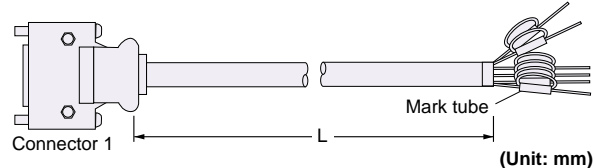

| Type | L |
|------------|-------------------------------------|
| WSC-D26P03 | 3000 ⁺³⁰⁰ / ₀ |

Series: Option cable for input/output of control signals
(directly connected to SX bus)

Type: WSC-D36P03

Applicable amplifier: RYS□□□S3-VSS, LPS, and RPS (CN1)

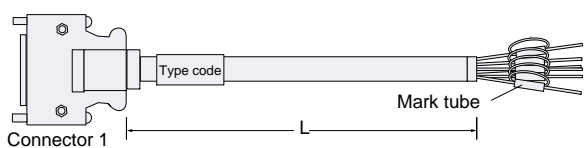

| Type | L |
|------------|-------------------------------------|
| WSC-D36P03 | 3000 ⁺³⁰⁰ / ₀ |

Series: Cable for servomotor encoder

Type: WSC-P06P05 to WSC-P06P20

Application range: 0.75kW or less

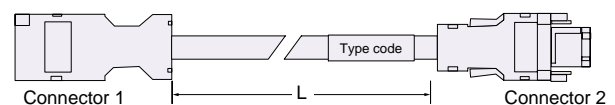

| Type | L |
|------------|---------------------------------------|
| WSC-P06P05 | 5000 ⁺⁵⁰⁰ / ₀ |
| WSC-P06P10 | 10000 ⁺¹⁰⁰⁰ / ₀ |
| WSC-P06P20 | 20000 ⁺²⁰⁰⁰ / ₀ |

EXTERNAL DIMENSIONS

Option

Series: Cable for servomotor encoder
Type: WSC-P06P05-C to WSC-P06P20-C
Application range: 1.0kW or over

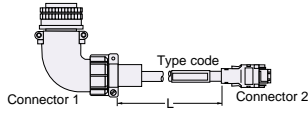

| Type | L (Unit: mm) |
|--------------|-------------------------------------|
| WSC-P06P05-C | 5000 ⁺⁵⁰⁰ ₀ |
| WSC-P06P10-C | 10000 ⁺¹⁰⁰⁰ ₀ |
| WSC-P06P20-C | 20000 ⁺²⁰⁰⁰ ₀ |

Series: Cable for servomotor encoder
Type: WSC-P06P05-W to WSC-P06P20-W
Application range: All models

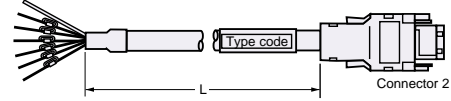

| Type | L (Unit: mm) |
|--------------|-------------------------------------|
| WSC-P06P05-W | 5000 ⁺⁵⁰⁰ ₀ |
| WSC-P06P10-W | 10000 ⁺¹⁰⁰⁰ ₀ |
| WSC-P06P20-W | 20000 ⁺²⁰⁰⁰ ₀ |

Series: Option cable for distributing power to the servomotor
Type: WSC-M04P05 to WSC-M04P20
Application range: 0.75kW or less

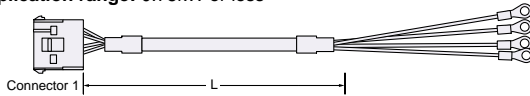

| Type | L (Unit: mm) |
|------------|-------------------------------------|
| WSC-M04P05 | 5000 ⁺⁵⁰⁰ ₀ |
| WSC-M04P10 | 10000 ⁺¹⁰⁰⁰ ₀ |
| WSC-M04P20 | 20000 ⁺²⁰⁰⁰ ₀ |

Series: Power cable for servomotor (with brake)
Type: WSC-P06P05-W to WSC-M06P20
Application range: 0.75kW or less

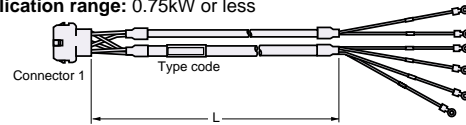

| Type | L (Unit: mm) |
|------------|-------------------------------------|
| WSC-M06P05 | 5000 ⁺⁵⁰⁰ ₀ |
| WSC-M06P10 | 10000 ⁺¹⁰⁰⁰ ₀ |
| WSC-M06P20 | 20000 ⁺²⁰⁰⁰ ₀ |

Series: External regenerative resistor
Type: WRS-401
Application range: RYS type servo amplifier with a capacity of 0.4 kW or less

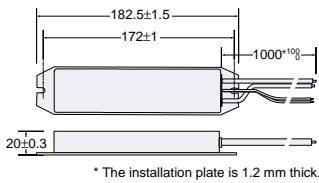

| Item | Specifications | |
|------------|---------------------|-----------------------|
| Type | WSR-401 | |
| Resistor | Resistance | 68Ω |
| | Allowable power | 17W (continuous) |
| | Working temperature | Opens at 135±5°C |
| Thermistor | Withstand voltage | 1.5kV AC for 1 minute |
| | Contact capacity | 30V DC, 3A |

Series: External regenerative resistor
Type: WSR-152
Application range: RYS type servo amplifier with a capacity of 1.0 or 1.5kW

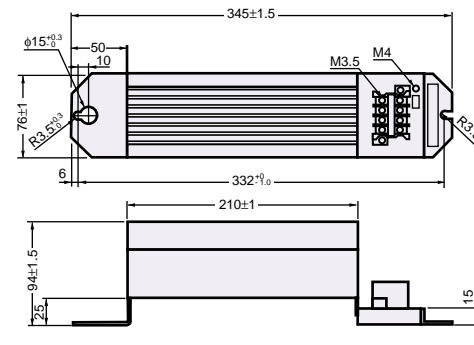

| Item | Specifications | |
|------------|---------------------|-----------------------|
| Type | WSR-152 | |
| Resistor | Resistance | 15Ω |
| | Allowable power | 75W (continuous) |
| | Working temperature | Opens at 150±10°C |
| Thermistor | Withstand voltage | 2.5kV AC for 1 minute |
| | Contact capacity | 30V DC, 3A |

Series: External regenerative resistor
Type: WRS-751
Application range: RYS type servo amplifier with a capacity of 0.75kW

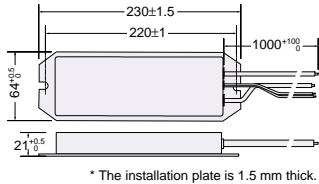

| Item | Specifications | |
|------------|---------------------|-----------------------|
| Type | WSR-751 | |
| Resistor | Resistance | 15Ω |
| | Allowable power | 25W (continuous) |
| | Working temperature | Opens at 135±5°C |
| Thermistor | Withstand voltage | 2.5kV AC for 1 minute |
| | Contact capacity | 30V DC, 3A |

Series: External regenerative resistor
Type: DB11-2
Application range: RYS type servo amplifier with a capacity of 2.0 or 3.0kW

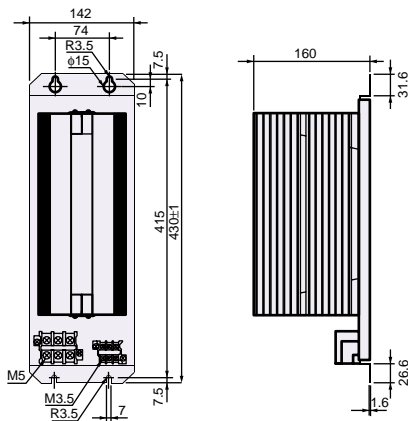

| Item | Specifications | |
|------------|---------------------|----------------------------|
| Type | DB11-2 | |
| Resistor | Resistance | 10Ω |
| | Allowable power | 115W (continuous) |
| | Working temperature | Opens at 150±10°C |
| Thermistor | Withstand voltage | 2.5kV AC for 1 minute |
| | Contact capacity | 120V AC, 0.1A/30V DC, 0.1A |

Series: External regenerative resistor
Type: DB22-2
Application range: RYS type servo amplifier with a capacity of 4.0 or 5.0kW

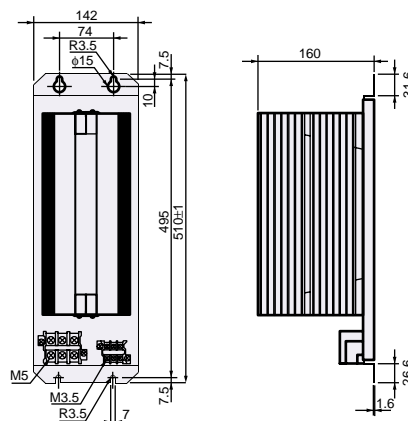

| Item | Specifications | |
|------------|---------------------|----------------------------|
| Type | DB22-2 | |
| Resistor | Resistance | 5.8Ω |
| | Allowable power | 115W (continuous) |
| | Working temperature | Opens at 150±10°C |
| Thermistor | Withstand voltage | 2.5kV AC for 1 minute |
| | Contact capacity | 120V AC, 0.1A/30V DC, 0.1A |

Explanation of Model Codes

■ Servo amplifier

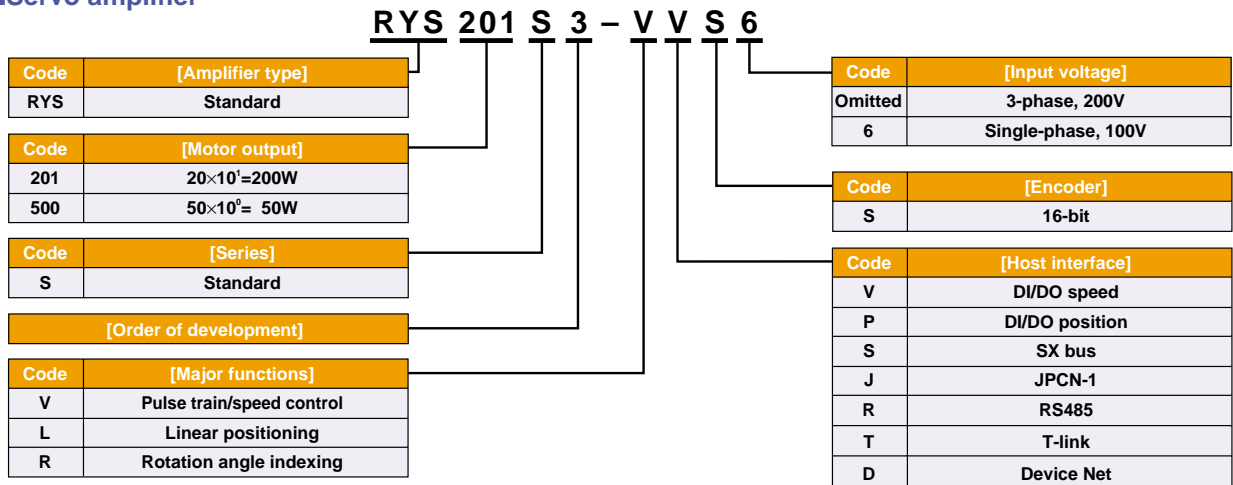

■ Servomotor

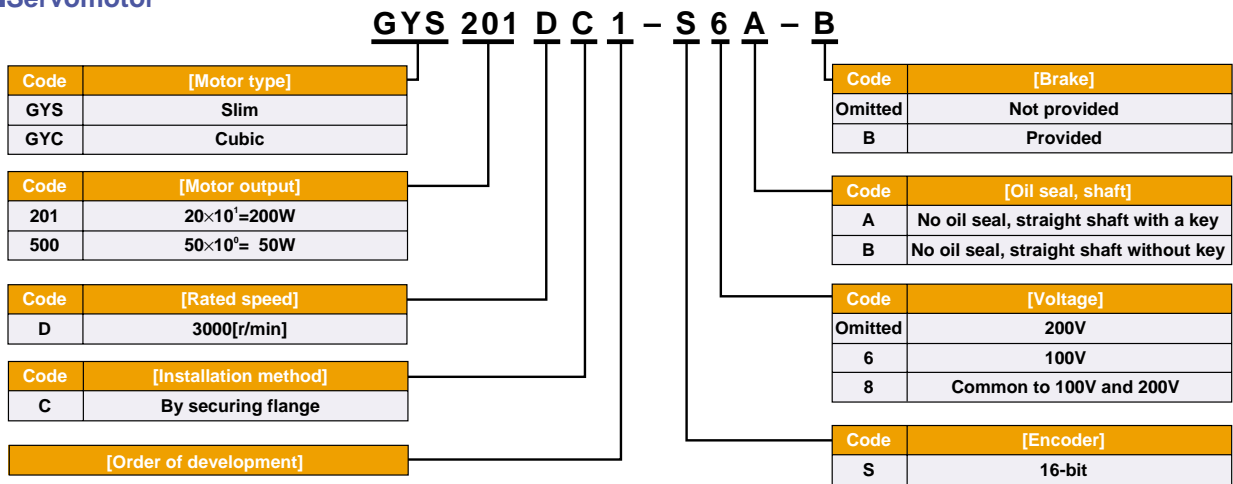

■ Gear Head 1

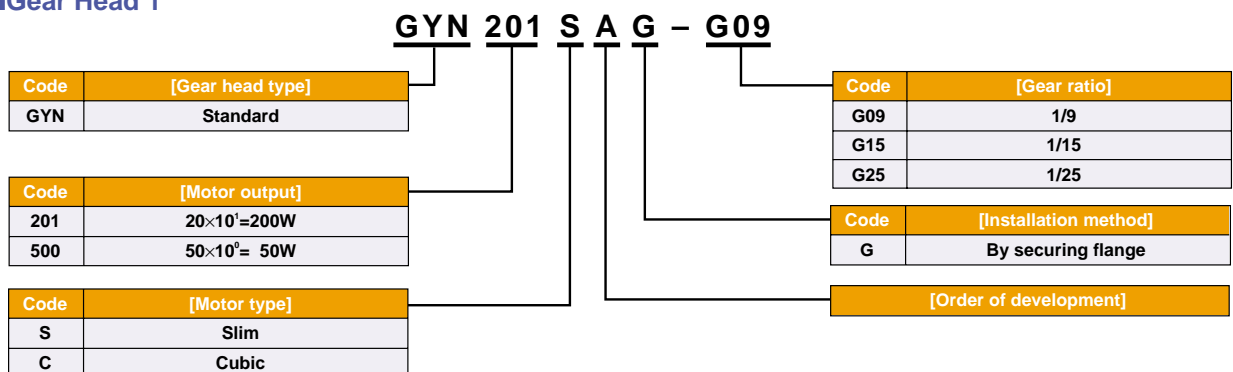

■ Gear Head 2

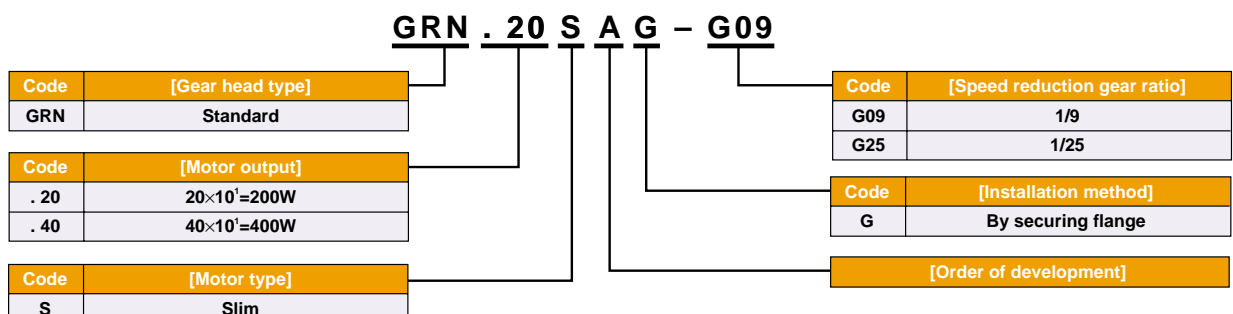

Type List

Servomotor

| Motor type | Specifications | | | Part code | Type | | |
|---------------------------------------|----------------|--------------------|--------------|--------------------|-----------------|---------|-----------------|
| | Voltage | Model | Rated output | | | | |
| GYC series servomotor (cubic type) | 200V | Standard motor | 0.1 kW | GYC1000 | GYC101DC1-SA | | |
| | | | 0.2 kW | GYC1001 | GYC201DC1-SA | | |
| | | | 0.4 kW | GYC1002 | GYC401DC1-SA | | |
| | | | 0.75 kW | GYC1003 | GYC751DC1-SA | | |
| | | | 1.0 kW | GYC1004 | GYC102DC1-SA | | |
| | | | 1.5 kW | GYC1005 | GYC152DC1-SA | | |
| | | Motor with a brake | 2.0 kW | GYC1006 | GYC202DC1-SA | | |
| | | | 0.1 kW | GYC1020 | GYC101DC1-SA-B | | |
| | | | 0.2 kW | GYC1021 | GYC201DC1-SA-B | | |
| | | | 0.4 kW | GYC1022 | GYC401DC1-SA-B | | |
| | | | 0.75 kW | GYC1023 | GYC751DC1-SA-B | | |
| | | | 1.0 kW | GYC1024 | GYC102DC1-SA-B | | |
| | | | 1.5 kW | GYC1025 | GYC152DC1-SA-B | | |
| | | | 2.0 kW | GYC1026 | GYC202DC1-SA-B | | |
| GYS series servomotor (slim type) | 100V/200V | Standard motor | 0.05 kW | GYS1001 | GYS500DC1-S8B | | |
| | 200V | Standard motor | 0.1 kW | GYS1002 | GYS101DC1-SB | | |
| | | | 0.2 kW | GYS1003 | GYS201DC1-SA | | |
| | | | 0.4 kW | GYS1004 | GYS401DC1-SA | | |
| | | | 0.75 kW | GYS1005 | GYS751DC1-SA | | |
| | | | 1.0 kW | GYS1006 | GYS102DC1-SA | | |
| | | | 1.5 kW | GYS1007 | GYS152DC1-SA | | |
| | | | 2.0 kW | GYS1008 | GYS202DC1-SA | | |
| | | | 3.0 kW | GYS1009 | GYS302DC1-SA | | |
| | | | 4.0 kW | GYS1010 | GYS402DC1-SA | | |
| | | | 5.0 kW | GYS1011 | GYS502DC1-SA | | |
| | 100V/200V | Motor with a brake | 0.05 kW | GYS1021 | GYS500DC1-S8B-B | | |
| | 200V | Motor with a brake | 0.1 kW | GYS1022 | GYS101DC1-SB-B | | |
| | | | 0.2 kW | GYS1023 | GYS201DC1-SA-B | | |
| | | | 0.4 kW | GYS1024 | GYS401DC1-SA-B | | |
| | | | 0.75 kW | GYS1025 | GYS751DC1-SA-B | | |
| | | | 1.0 kW | GYS1026 | GYS102DC1-SA-B | | |
| | | | 1.5 kW | GYS1027 | GYS152DC1-SA-B | | |
| | | | 2.0 kW | GYS1028 | GYS202DC1-SA-B | | |
| | | | 3.0 kW | GYS1029 | GYS302DC1-SA-B | | |
| | | | 4.0 kW | GYS1030 | GYS402DC1-SA-B | | |
| | | | 5.0 kW | GYS1031 | GYS502DC1-SA-B | | |
| | | | 100V | Standard motor | 0.1 kW | GYS1042 | GYS101DC1-S6B |
| | | | | | 0.2 kW | GYS1043 | GYS201DC1-S6B |
| | | | | Motor with a brake | 0.1 kW | GYS1052 | GYS101DC1-S6B-B |
| | | | | | 0.2 kW | GYS1053 | GYS201DC1-S6B-B |

Gear Head

| Applied motor | Gear ratio | Applied motor capacity | Part code | Type | |
|---------------------------------------|--------------------------------------|------------------------|---------------|---------------|---------------|
| GYC series servomotor (cubic type) | 1/9 | 0.1kW | GYN100C | GYN101CAG-G09 | |
| | | 0.2kW | GYN101C | GYN201CAG-G09 | |
| | | 0.4kW | GYN102C | GYN401CAG-G09 | |
| | | 0.75kW | GYN103C | GYN751CAG-G09 | |
| | | 1.0kW | GYN104C | GYN102CAG-G09 | |
| | | 1.5kW | GYN105C | GYN152CAG-G09 | |
| | 1/25 | 2.0kW | GYN106C | GYN202CAG-G09 | |
| | | 0.1kW | GYN120C | GYN101CAG-G25 | |
| | | 0.2kW | GYN121C | GYN201CAG-G25 | |
| | | 0.4kW | GYN122C | GYN401CAG-G25 | |
| | | 0.75kW | GYN123C | GYN751CAG-G25 | |
| | | 1.0kW | GYN124C | GYN102CAG-G15 | |
| 1/15 | 1.5kW | GYN125C | GYN152CAG-G15 | | |
| | 2.0kW | GYN126C | GYN202CAG-G15 | | |
| | GYS series servomotor (slim type) | 1/9 | 0.05kW | GYN101S | GYN500SAG-G09 |
| | | | 0.1kW | GYN102S | GYN101SAG-G09 |
| | | | 0.2kW | GYN103S | GYN201SAG-G09 |
| | | | | GRN003S | GRN.20SAG-G09 |
| 0.4kW | | | GYN104S | GYN401SAG-G09 | |
| | | | GRN004S | GRN.40SAG-G09 | |
| 0.75kW | | | GYN105S | GYN751SAG-G09 | |
| 1.0kW | | | GYN106S | GYN102SAG-G09 | |
| 1.5kW | | GYN107S | GYN152SAG-G09 | | |
| 2.0kW | | GYN108S | GYN202SAG-G09 | | |
| 1/25 | | 0.05kW | GYN121S | GYN500SAG-G25 | |
| | | 0.1kW | GYN122S | GYN101SAG-G25 | |
| | 0.2kW | GYN123S | GYN201SAG-G25 | | |
| | | GRN013S | GRN.20SAG-G25 | | |
| | 0.4kW | GYN124S | GYN401SAG-G25 | | |
| | | GRN014S | GRN.40SAG-G25 | | |
| 0.75kW | GYN125S | GYN751SAG-G25 | | | |
| 1/15 | 1.0kW | GYN126S | GYN102SAG-G15 | | |
| | 1.5kW | GYN127S | GYN152SAG-G15 | | |
| | 2.0kW | GYN128S | GYN202SAG-G15 | | |

Servo Amplifier

| Type | Input voltage | Host interface | Applied motor capacity | Part code | Type | | | |
|---------------------------|---|----------------|---|--------------|---------------|--------------|--------------|--------------|
| Pulse train/speed control | 3-phase 200V | DI/DO | 0.05kW | RYS1001 | RYS500S3-VVS | | | |
| | | | 0.1kW | RYS1002 | RYS101S3-VVS | | | |
| | | | 0.2kW | RYS1003 | RYS201S3-VVS | | | |
| | | | 0.4kW | RYS1004 | RYS401S3-VVS | | | |
| | | | 0.75kW | RYS1005 | RYS751S3-VVS | | | |
| | | | 1.0kW | RYS1006 | RYS102S3-VVS | | | |
| | | | 1.5kW | RYS1007 | RYS152S3-VVS | | | |
| | | | 2.0kW | RYS1008 | RYS202S3-VVS | | | |
| | | | 3.0kW | RYS1009 | RYS302S3-VVS | | | |
| | | | 4.0kW | RYS1010 | RYS402S3-VVS | | | |
| | Single-phase 100V | DI/DO | 0.05kW | RYS3073 | RYS500S3-VVS6 | | | |
| | | | 0.1kW | RYS3074 | RYS101S3-VVS6 | | | |
| | | | 0.2kW | RYS3075 | RYS201S3-VVS6 | | | |
| | 3-phase 200V | SX bus | 0.05kW | RYS3013 | RYS500S3-VSS | | | |
| | | | 0.1kW | RYS3014 | RYS101S3-VSS | | | |
| | | | 0.2kW | RYS3015 | RYS201S3-VSS | | | |
| | | | 0.4kW | RYS3016 | RYS401S3-VSS | | | |
| | | | 0.75kW | RYS3017 | RYS751S3-VSS | | | |
| | | | 1.0kW | RYS3018 | RYS102S3-VSS | | | |
| | | | 1.5kW | RYS3019 | RYS152S3-VSS | | | |
| | | | 2.0kW | RYS3020 | RYS202S3-VSS | | | |
| | | | 3.0kW | RYS3021 | RYS302S3-VSS | | | |
| | | | 4.0kW | RYS3022 | RYS402S3-VSS | | | |
| | | | 5.0kW | RYS3023 | RYS502S3-VSS | | | |
| | | | Linear positioning function built in type | 3-phase 200V | DI/DO | 0.05kW | RYS3025 | RYS500S3-LPS |
| | | | | | | 0.1kW | RYS3026 | RYS101S3-LPS |
| | | | | | | 0.2kW | RYS3027 | RYS201S3-LPS |
| 0.4kW | RYS3028 | RYS401S3-LPS | | | | | | |
| 0.75kW | RYS3029 | RYS751S3-LPS | | | | | | |
| 1.0kW | RYS3030 | RYS102S3-LPS | | | | | | |
| 1.5kW | RYS3031 | RYS152S3-LPS | | | | | | |
| 2.0kW | RYS3032 | RYS202S3-LPS | | | | | | |
| 3.0kW | RYS3033 | RYS302S3-LPS | | | | | | |
| 4.0kW | RYS3034 | RYS402S3-LPS | | | | | | |
| 5.0kW | RYS3035 | RYS502S3-LPS | | | | | | |
| SX bus | 0.05kW | RYS3037 | | | | RYS500S3-LSS | | |
| | 0.1kW | RYS3038 | | | | RYS101S3-LSS | | |
| | 0.2kW | RYS3039 | | | | RYS201S3-LSS | | |
| | 0.4kW | RYS3040 | | | | RYS401S3-LSS | | |
| | 0.75kW | RYS3041 | | | | RYS751S3-LSS | | |
| | 1.0kW | RYS3042 | | | | RYS102S3-LSS | | |
| | 1.5kW | RYS3043 | | | | RYS152S3-LSS | | |
| | 2.0kW | RYS3044 | | | RYS202S3-LSS | | | |
| | 3.0kW | RYS3045 | | | RYS302S3-LSS | | | |
| | 4.0kW | RYS3046 | | | RYS402S3-LSS | | | |
| | 5.0kW | RYS3047 | | | RYS502S3-LSS | | | |
| | T-link | 0.05kW | | | --- | RYS500S3-LTS | | |
| 0.1kW | | --- | | | RYS101S3-LTS | | | |
| 0.2kW | | --- | | | RYS201S3-LTS | | | |
| 0.4kW | | --- | | | RYS401S3-LTS | | | |
| 0.75kW | | --- | | | RYS751S3-LTS | | | |
| 1.0kW | | --- | | | RYS102S3-LTS | | | |
| RS485 | 1.5kW | --- | | | RYS152S3-LTS | | | |
| | 0.05kW | --- | | | RYS500S3-LRS | | | |
| | 0.1kW | --- | | | RYS101S3-LRS | | | |
| | 0.2kW | --- | | | RYS201S3-LRS | | | |
| | 0.4kW | --- | | | RYS401S3-LRS | | | |
| | 0.75kW | --- | | | RYS751S3-LRS | | | |
| | 1.0kW | --- | | | RYS102S3-LRS | | | |
| | 1.5kW | --- | | | RYS152S3-LRS | | | |
| | Rotation angle index function built-in type | 3-phase 200V | | | DI/DO | 0.05kW | RYS3049 | RYS500S3-RPS |
| 0.1kW | | | | | | RYS3050 | RYS101S3-RPS | |
| 0.2kW | | | | | | RYS3051 | RYS201S3-RPS | |
| 0.4kW | | | | | | RYS3052 | RYS401S3-RPS | |
| 0.75kW | | | | | | RYS3053 | RYS751S3-RPS | |
| 1.0kW | | | | | | RYS3054 | RYS102S3-RPS | |
| 1.5kW | | | RYS3055 | RYS152S3-RPS | | | | |
| 2.0kW | | | RYS3056 | RYS202S3-RPS | | | | |
| 3.0kW | | | RYS3057 | RYS302S3-RPS | | | | |
| 4.0kW | | | RYS3058 | RYS402S3-RPS | | | | |
| 5.0kW | | | RYS3059 | RYS502S3-RPS | | | | |
| SX bus | | | 0.05kW | RYS3061 | | RYS500S3-RSS | | |
| | | | 0.1kW | RYS3062 | | RYS101S3-RSS | | |
| | | | 0.2kW | RYS3063 | | RYS201S3-RSS | | |
| | | | 0.4kW | RYS3064 | | RYS401S3-RSS | | |
| | | | 0.75kW | RYS3065 | | RYS751S3-RSS | | |
| | | | 1.0kW | RYS3066 | | RYS102S3-RSS | | |
| | | | 1.5kW | RYS3067 | | RYS152S3-RSS | | |
| | | | 2.0kW | RYS3068 | RYS202S3-RSS | | | |
| | | | 3.0kW | RYS3069 | RYS302S3-RSS | | | |
| | | | 4.0kW | RYS3070 | RYS402S3-RSS | | | |
| | | | 5.0kW | RYS3071 | RYS502S3-RSS | | | |
| | | | T-link | 0.05kW | --- | RYS500S3-RTS | | |
| 0.1kW | | | | --- | RYS101S3-RTS | | | |
| 0.2kW | | | | --- | RYS201S3-RTS | | | |
| 0.4kW | | | | --- | RYS401S3-RTS | | | |
| 0.75kW | | | | --- | RYS751S3-RTS | | | |
| 1.0kW | | | | --- | RYS102S3-RTS | | | |
| 1.5kW | | | --- | RYS152S3-RTS | | | | |

3-phase 200V series

Option

| Part Name | | Part Code | Type | |
|--|---|---------------------------|--------------|--------------|
| Cable for input/output of control signals (CN1, CN3) | DI/DO standard 36 pins (CN1) | 3m (one-end connector) | RYWS802 | WSC-D36P03 |
| | DI/DO extended 20 pins (CN3) for L type and R type | | RYWS800 | WSC-D20P03 |
| | 26 pins (CN1) for SX bus, T-link, RS485 | | RYWS801 | WSC-D26P03 |
| Cable for Servomotor encoder (CN2) | 0.75kW or less | 5m (both-end connector) | RYWS803 | WSC-P06P05 |
| | | 10m (both-end connector) | RYWS804 | WSC-P06P10 |
| | | 20m (both-end connector) | RYWS805 | WSC-P06P20 |
| | 1.0kW or over | 5m (both-end connector) | RYWS806 | WSC-P06P05-C |
| | | 10m (both-end connector) | RYWS807 | WSC-P06P10-C |
| | | 20m (both-end connector) | RYWS808 | WSC-P06P20-C |
| | Common to all the models (connector kit required for motor) | 5m (one-end connector) | RYWS821 | WSC-P06P05-W |
| 10m (one-end connector) | | RYWS822 | WSC-P06P10-W | |
| 20m (one-end connector) | | RYWS823 | WSC-P06P20-W | |
| Servomotor power cable (without brake) | 0.75kW or less | 5m (one-end connector) | RYWS809 | WSC-M04P05 |
| | | 10m (one-end connector) | RYWS810 | WSC-M04P10 |
| | | 20m (one-end connector) | RYWS811 | WSC-M04P20 |
| Servomotor power cable (with brake) | 0.75kW or less | 5m (one-end connector) | RYWS815 | WSC-M06P05 |
| | | 10m (one-end connector) | RYWS816 | WSC-M06P10 |
| | | 20m (one-end connector) | RYWS817 | WSC-M06P20 |
| Connector kit for control I/O wiring (CN1, CN3) | DI/DO standard 36 pins (CN1) | --- | RYWS022 | WSK-D36P |
| | DI/DO extended 20 pins (CN3) L type, R type | --- | RYWS020 | WSK-D20P |
| | SX bus, T-link, RS485 26 pins (CN1) | --- | RYWS021 | WSK-D26P |
| Connector kit for wiring of encoder (CN2) | Common to all the models | --- | RYWS023 | WSK-P06P-M |
| | 0.75kW or less | --- | RYWS024 | WSK-P06P-F |
| | 1kW or over | --- | RYWS025 | WSK-P06P-C |
| Connector kit for power cables (without brake) | 0.75kW or less | --- | RYWS026 | WSK-M04P |
| | Slim type 1.0 to 2.0kW | --- | RYWS027 | WSK-M04P-CA |
| | Cubic type 1.0kW or over | --- | RYWS031 | WSK-M04P-CB |
| Slim type 3.0kW or over | --- | | | |
| Connector kit for power cables (with brake) | 0.75kW or less | --- | RYWS028 | WSK-M06P |
| | Slim type 1.0 to 2.0kW | --- | RYWS029 | WSK-M06P-CA |
| | Cubic type 1.0kW or over | --- | RYWS032 | WSK-M06P-CB |
| | Slim type 3.0kW or over | --- | | |
| Connector kit for control power input | 1.5kW or less (L1C, L2C) | --- | RYWS030 | WSK-L02P |
| Battery (with connector) | Common to all the models | --- | RYWS003 | WSB-S |
| External regenerative resistor | For 0.4kW or less | 1m extended line | RYWS010 | WSR-401 |
| | For 0.7.5kW | 1m extended line | RYWS011 | WSR-751 |
| | For 1.0kW, 1.5kW | Terminal base | RYWS012 | WSR-152 |
| | 2.0kW, 3.0kW (inverter option) | Terminal base | RGWG339 | DB11-2 |
| | 4.0kW, 5.0kW (inverter option) | Terminal base | RGWG342 | DB22-2 |
| Personal computer loader (CD) | Common to all the models | --- | RYWS002 | WSL-PC |
| Converter-equipped cable for PC loader | Common to all the models (option for MICREX-SX) | 2m (both-end connector) | NP4H004 | NP4H-CNV |
| SX bus extension cable | Common to all the models (option for MICREX-SX) | 0.3m (both-end connector) | NP1C001 | NP1C-P3 |

Alarm list

If an alarm is detected, the detected contents are displayed on the touch panel of amplifier.

| Priority order | Display | Description |
|----------------|---------|---------------------------------|
| 1 | SE | System error |
| 2 | OC | Overcurrent |
| 3 | OS | Overspeed |
| 4 | LV | Low voltage |
| 5 | HV | High voltage |
| 6 | Et | Encoder trouble |
| 7 | Ct | Control circuit trouble |
| 8 | Fb | Fuse blown |
| 9 | dE | Data error (memory error) |
| 10 | CE | Combination error |
| 11 | rH2 | Resistor heat 2 |
| 12 | EC | Encoder communication error |
| 13 | CtE | Cont (control signal) error |
| 14 | OL | Overload |
| 15 | AH | Amplifier overheat |
| 16 | rH | Baking resistor overheat |
| 17 | OF | Over flow (excessive deviation) |
| 18 | EH | Encoder overheat |
| 19 | AL | Absolute data lost |
| 20 | RF | Absolute data overflow |
| 21 | tE | Terminal error |
| 22 | --- | (non) |

If several alarms are detected simultaneously, the touch panel displays the alarm with higher priority as indicated above.

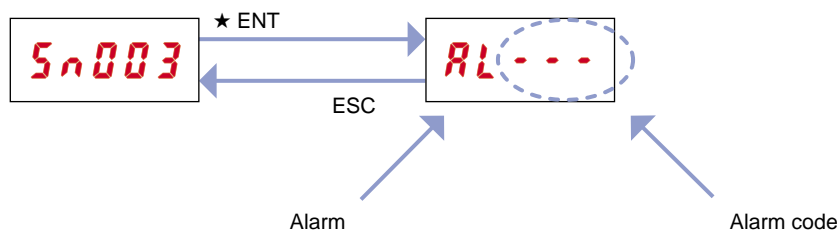



★: 1[sec] min.

Remarks:

An alarm is displayed automatically if detected.

If, at a displayed status, the alarm detection is reset by a control input signal, the initial screen (system para. 89 setting) appears.

The alarm detection can be reset also in the test running mode [Fn004].

Alarm detection can be reset while the alarm is displayed by holding down the  key and  key simultaneously for at least 1 second.

Fuji Electric Co., Ltd.

ED & C • Drive Systems Company

Gate City Ohsaki, East Tower, 11-2, Osaki 1-chome

Shinagawa-ku, Tokyo 141-0032, Japan

Phone: +81-3-5435-7139 Fax: +81-3-5435-7460



Printed on 100% recycled paper