



General Duty Switch



Heavy Duty Switch



Window Switch

## contents

Safety Switch Guide Form Specifications	4-2
Feature Comparison	4-3
Enclosure Types	4-4
Catalog Numbering System	4-5
<b>General Duty Safety Switches</b>	
Plug Fuse Enclosed Type, 120/240V Fusible—Selection	4-6
60A Special Application Type, 240V Non-Fusible—Selection	4-6
General Duty Switches—Features	4-7
240V Fusible and Non-Fusible—Selection	4-8
<b>Heavy Duty Safety Switches</b>	
Heavy Duty Switches—Features	4-9
240V Fusible—Selection	4-10
600V Fusible—Selection	4-11
600V Non-Fusible—Selection	4-12
Type 4/4X and 12 with Viewing Window—Selection	4-13
<b>Special Applications Safety Switches</b>	
Type ECS Elevator Control Switches	4-14 – 4-15
4-Pole and 6-Pole—Selection	4-16
Interlocked Receptacle—Selection	4-17
Non-Metallic and 316 Grade Stainless—Selection	4-18
Enclosed Solar PV Disconnects	4-19
<b>Accessories—General and Heavy Duty Switches</b>	
Class R Fuse Clips, Class J Fusing, Class T Fuse Adapter Kits	4-20
Neutral Kits, 200% Neutral Kits, Fuse Puller Kits	4-20
Auxiliary Contacts, Copper Lug Kits	4-21
Equipment Ground Kits, Isolated Ground Kits	4-21
Interchangeable Hubs	4-22
Compression Lug, Neutral Barrier Kits, Lugs and Wire Ranges	4-22
Multiple Padlocks, Kirk-Key Interlocks	4-22
<b>Dimensions and Weights</b>	
General and Heavy Duty Switches	4-23 – s
Type 1 and 3R Knockout Diagrams	4-27 – 4-28
Non-Metallic and Receptacle Switch Dimensions	4-29
4-Pole and 6-Pole Switch Dimensions	4-30
<b>Double-Throw Switches</b>	
Selection	4-31 – 4-32
Dimensions	4-33
Enclosed Rotary Disconnect Switches	4-34 – 4-35
VBII Safety Switch Replacement Parts	4-36

Scan to connect online to the most up-to-date version of this Section of SPEEDFAX.



# Type VBII Safety Switches

	General Duty	Heavy Duty	Double Throw																																							
<b>Application</b>	General Duty Switches are intended for applications where reliable performance and continuity of service are needed, but where duty requirements are not severe and usual service conditions prevail. (These switches are intended for use primarily with supply circuits rated 240V AC or less where the available fault current is less than 100,000A when used with Class R or T fuses or 10,000A max. when used with Class H fuses.)	Heavy Duty Switches are intended for use in applications where: <ol style="list-style-type: none"> <li>1. Rugged construction, reliable performance, continuity of service and ease of maintenance are emphasized, or</li> <li>2. Available fault currents higher than 10,000A are likely to be encountered, such as in manufacturing plants, mass production industries, and commercial, institutional and other large buildings served by network systems or transformers of higher capacities.</li> <li>3. System voltage is 600V AC or DC Max.</li> <li>4. A Type 12 or 4 / 4X enclosure is required.</li> </ol>	Double throw switches are intended to transfer loads from one power source to another. All 2 & 3 pole double throw switches are suitable for use as service equipment. All are UL Listed. Switches are rated for use on systems with an available fault current of up to 10,000 AIC when protected with Class H fuses or either 100,000 or 200,000 AIC when protected with Class R, J or Class T fuses. They can also be used to connect a single source of power to either of two loads. In this application it is necessary to field modify fusible switches so that the fuses are on the load side of the switching mechanism.																																							
<b>Short Circuit Withstand Ratings</b>	Suitable for use on systems capable of delivering not more than 100,000 RMS symmetrical amperes of fault current as follows: <table border="1" style="margin-left: 20px;"> <thead> <tr> <th>Sw. Rating</th> <th>AIC Rating</th> <th>Protective Device<sup>Ⓞ</sup></th> </tr> </thead> <tbody> <tr> <td>30-600A</td> <td>10,000</td> <td>Circuit Breaker</td> </tr> <tr> <td>30-600A</td> <td>10,000</td> <td>Class H Fuse</td> </tr> <tr> <td>30-600A</td> <td>100,000</td> <td>Class R Fuse</td> </tr> <tr> <td>100-600A</td> <td>100,000</td> <td>Class J or T Fuse</td> </tr> </tbody> </table>	Sw. Rating	AIC Rating	Protective Device <sup>Ⓞ</sup>	30-600A	10,000	Circuit Breaker	30-600A	10,000	Class H Fuse	30-600A	100,000	Class R Fuse	100-600A	100,000	Class J or T Fuse	Suitable for use on systems capable of delivering not more than 200,000 RMS symmetrical amperes of fault current as follows: <table border="1" style="margin-left: 20px;"> <thead> <tr> <th>Sw. Rating &amp; Type</th> <th>AIC Rating</th> <th>Protective Device<sup>Ⓞ</sup></th> </tr> </thead> <tbody> <tr> <td>All Heavy Duty &amp; DT</td> <td>10,000</td> <td>Circuit Breaker</td> </tr> <tr> <td>30-600A HD &amp; DT</td> <td>10,000</td> <td>Class H Fuse</td> </tr> <tr> <td>60A Compact HD</td> <td>100,000</td> <td>Class R, J or T Fuse</td> </tr> <tr> <td>GD &amp; 4P DT</td> <td>100,000</td> <td>Class R, J or T Fuse</td> </tr> <tr> <td>30-600A HD</td> <td>200,000</td> <td>Class R, J or T Fuse</td> </tr> <tr> <td>30-600A DTF &amp; DTNF DT<sup>Ⓞ</sup></td> <td>200,000</td> <td>Class R, J or T Fuse</td> </tr> <tr> <td>800 &amp; 1200A HD &amp; DT<sup>Ⓞ</sup></td> <td>200,000</td> <td>Class L or T Fuse</td> </tr> </tbody> </table>	Sw. Rating & Type	AIC Rating	Protective Device <sup>Ⓞ</sup>	All Heavy Duty & DT	10,000	Circuit Breaker	30-600A HD & DT	10,000	Class H Fuse	60A Compact HD	100,000	Class R, J or T Fuse	GD & 4P DT	100,000	Class R, J or T Fuse	30-600A HD	200,000	Class R, J or T Fuse	30-600A DTF & DTNF DT <sup>Ⓞ</sup>	200,000	Class R, J or T Fuse	800 & 1200A HD & DT <sup>Ⓞ</sup>	200,000	Class L or T Fuse	
Sw. Rating	AIC Rating	Protective Device <sup>Ⓞ</sup>																																								
30-600A	10,000	Circuit Breaker																																								
30-600A	10,000	Class H Fuse																																								
30-600A	100,000	Class R Fuse																																								
100-600A	100,000	Class J or T Fuse																																								
Sw. Rating & Type	AIC Rating	Protective Device <sup>Ⓞ</sup>																																								
All Heavy Duty & DT	10,000	Circuit Breaker																																								
30-600A HD & DT	10,000	Class H Fuse																																								
60A Compact HD	100,000	Class R, J or T Fuse																																								
GD & 4P DT	100,000	Class R, J or T Fuse																																								
30-600A HD	200,000	Class R, J or T Fuse																																								
30-600A DTF & DTNF DT <sup>Ⓞ</sup>	200,000	Class R, J or T Fuse																																								
800 & 1200A HD & DT <sup>Ⓞ</sup>	200,000	Class L or T Fuse																																								
<b>Fuses</b>	Fusible switches will accept the following UL class fuses: 30 "LF" - 30A max plug Fuses 30-600A "GF" Class H & K, Class R with kit 100-600A "GF" Class J-move base 100-200 "GF" Class T with kit 400-600A "GF" Class T-move bases	Fusible switches will accept the following UL class fuses: 30-600A "HF" Class H & K, Class R with kit 30-400A, 600V "HF" Class J-move base 100-600A, 240V "HF" Class J-move base 100-200A "HF" Class T with kit 400-600A "HF" Class T-move bases 800-1200A "HF" Class L, Class T with kit <sup>Ⓞ</sup>	Fusible switches will accept the following UL class fuses: 30-200A "DT" & "F" Class H & K, Class R with kit 30 & 60A 600V "DT" Class J-move base 100-200A "DT" Class J-move base, Class T with kit 400-600A "DT" Class J-standard, Class T-move bases 400A 240v "F" Class H-standard 400A, 600V & 600A "F" Class T-Standard																																							
<b>Cover Interlocks</b>	Voidable – cover interlocks on switches prevent the switch door from being opened when in the "ON" position. No cover interlock on 30-60A GD or on plug fuse type switches.	Voidable dual cover interlocks standard on all heavy duty switches. Prevents cover from being opened when switch is in the "ON" position and prevents switch from being turned "ON" when door is opened.	Dual cover interlocks standard on all double throw switches. Prevents cover from being opened when switch is in the "ON" position and prevents switch from being turned "ON" when door is opened.																																							
<b>Underwriters' Laboratories, Inc.</b>	Listed by UL under file #E4776 as enclosed switches and also suitable for use as service equipment (where applicable). UL98 Enclosed and Deadfront Switches.																																									
<b>NEMA Specifications</b>	Meet NEMA standard KS-1-2001 for type GD switches.	Meet NEMA standard KS-1-2001 for type HD switches.	Meet NEMA standard KS-1-2001 type GD for "DTG" & type HD for "DT", "F" & "NF" switches.																																							
<b>Seismic Qualifications</b>	100-600A GD & all HD switches and "DT" type double throw switches have been tested and comply with the 2010 California Building Code (CBC) and with the 2009 International Building Code (IBC) - Compliance Level SDS = 1.85 g																																									
<b>Groundable Neutral</b> (All neutrals are bondable for service entrance use.)	Fusible switches have groundable neutral blocks factory installed. Non-fusible switches accept field addable neutrals.	All switches (both Fusible and Non-Fusible) are either supplied with factory installed neutrals or accept field addable neutrals.	All except 4 pole switches will accept field addable neutrals except that "DTG" 100 & 200A switches are also available with factory installed neutrals.																																							
<b>Padlocks</b>	Padlockable cover latch. OFF padlock provisions on handle.	Padlockable cover latch and multiple OFF padlock provisions on handle.	Padlockable cover latch and multiple OFF padlock provisions on handle.																																							
<b>HP &amp; Load Break Ratings</b>	All General Duty, Heavy Duty and Double Throw Switches are both load break and horsepower rated.																																									

<sup>Ⓞ</sup> The protective device can either be a fuse installed in a fusible switch or an upstream fuse or circuit breaker protecting a non-fusible switch. The ampere rating of the upstream protective device must not exceed the switch ampere rating. Ⓞ Class T kit available for 240V max. applications on 1200A switches.  
<sup>Ⓞ</sup> All 4 pole and fusible double switches with catalog numbers starting with "F" are rated 100,000 AIC max.

# Feature Comparison

General Duty	Heavy Duty	Double Throw	Features / Ratings
▪	▪	▪	30 thru 600 Amps
	▪	▪	800 and 1200 Amps
▪	▪	▪	240 Volt AC
	▪	▪	600 Volt AC
▪	▪	▪	250 Volt DC
	▪		600 Volt DC
▪	▪	▪	Double-break visible blade design (30-200A)
▪	▪	▪	Quick-make, quick-break switching action (excludes 30A GD)
	▪		Handle design for hook stick operation
▪	▪	▪	Padlockable cover latch
▪	▪	▪	Padlockable handle
▪		▪	Single voidable cover interlock (excludes 30-60A GD)
	▪	▪	Dual voidable cover interlock
▪	▪	▪	Type 1 enclosure
▪	▪	▪	Type 3R enclosure
	▪	▪	Type 12 enclosure
	▪	▪	Type 4 / 4X enclosures
▪	▪	▪	Generous wiring gutters that meet UL and NEC wire-bending space requirements
▪ <sup>⑤</sup>	▪	▪	Lugs suitable for copper or aluminum at 60° or 75°C
▪	▪	▪	CU/AL wire lugs that meet UL 486B requirements
	▪	▪	Suitable for field-convertible compression connectors
▪ <sup>④</sup>	▪	▪	All plated copper current carrying parts (except lugs)
▪	▪	▪	Spring reinforced Fuse Clips (except 30-60A GD) <sup>②</sup>
	▪	▪	Clear pivoting line terminal shield
▪	▪	▪	Replacement parts (except 30-60A GD)
	▪	▪	200% neutral available for purchase separately
▪ <sup>⑦</sup>	▪ <sup>①⑦</sup>	▪ <sup>①⑦</sup>	Provisions for UL Class T, R and H Fuses
	▪	▪ <sup>①</sup>	Provisions for UL Class J and L Fuses
	▪	▪	Metal nameplate
▪	▪	▪	Aux. switch kits (excludes 30-60A GD)
	▪ <sup>③</sup>		Type 4X with stainless steel interior parts
▪ <sup>④</sup>	▪		Rolled flange enclosure design (30-200A)
	▪	▪	Isolated ground kits

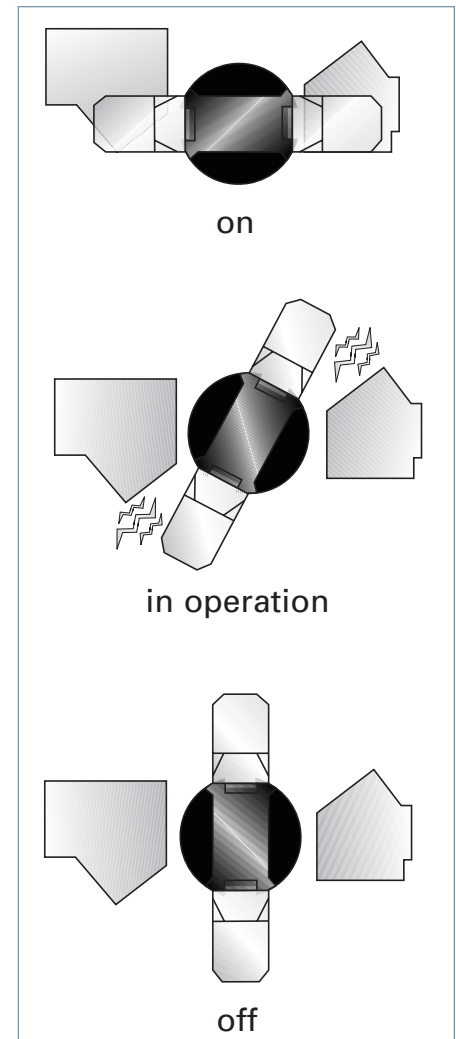

## Double Break Switching Action

Like the time-proven Vacu-Break Design, the Siemens VBII double break switching action breaks the arc in two places in 30-600A ratings. This reduces heat generation and increases switching speed by doubling the breaking distance. The result is enhanced performance and increased longevity. We also provide the most visible blade design available today. Unlike conventional knife blade switches, the blades are self-aligning to ensure positive contact. In addition, they have no wear and friction point since the “electrical hinge” has been eliminated. The result is a very fast, positive and reliable switching action for even the most severe applications.

① 400, 600V & 600A fusible, double-throw switches accept only Class J or T fuses. Only 800 & 1200A HD switches will accept Class L fuses.  
 ② 30-60A general duty switches have fuse clips constructed of spring type copper.

③ 30-200A Type VBII in stainless steel enclosures.  
 ④ 100-200A.  
 ⑤ 60A only suitable for Cu at 75°.

⑥ 200A general duty switches have aluminum neutral assemblies.  
 ⑦ 100-600A GD & DT and 100-1200A HD switches will accept Class T fuses.

# Safety Switches

General Duty and Heavy Duty

Product Overview

## Enclosure Types

- A Type 1** enclosures are intended for indoor use primarily to provide protection against contact with the enclosed equipment in locations where unusual service conditions do not exist.
- B Type 3R** enclosures are intended for outdoor use primarily to provide a degree of protection against falling rain and sleet and must remain undamaged by the formation of ice on the enclosure. They are not intended to provide protection against conditions such as dust, internal condensation, or internal icing.
- C Type 4, 4X** enclosures are intended for indoor or outdoor use primarily to provide a degree of protection against windblown dust, rain, splashing water and hose-directed water. They are not intended to provide protection against conditions such as internal condensation or internal icing. Also meets 4X definition by providing a high degree of protection against corrosion. Siemens 30-200A stainless steel 4X switches are supplied stainless interior parts and hardware as standard.
- D Type 4** enclosures are intended for indoor or outdoor use primarily to provide a degree of protection against windblown dust, rain, splashing water and hose-directed water. They are not intended to provide protection against conditions such as internal condensation or internal icing.
- E Type 12<sup>Ⓛ</sup>** enclosures are intended for indoor use primarily to provide a degree of protection against dust, falling dirt and dripping water. They are not intended to provide protection against conditions such as internal condensation.

**Type 7/9** enclosures for use in hazardous locations. Use with molded case switches listed in Section 7.

## Load Break Ratings

All Siemens safety switches are load break rated. The load break rating is assigned by UL after the switching unit has successfully performed the following tests:

Switch Ampere Rating	Number of ON/OFF Operations per Minute	Number of Operations		
		With Current	Without Current	Total
30-100	6	6000	4000	10000
200	5	6000	2000	8000
400	4	1000	5000	6000
600	3	1000	4000	5000
800	2	500	3000	3500
1200	1	500	2000	2500

## Horsepower Ratings

All Siemens safety switches, where appropriate, are horsepower rated. Ratings are approved by UL only after the switching unit has undergone testing to determine its acceptability which includes repeated interruption of the locked rotor current of the motor for which it is to be rated as follows:

Max HP Rating	Number of ON/OFF Operations per minute	Number of Cycles of Operation
100	6	50
500	1	10



## Non-Fusible Safety Switch AIC Ratings When Protected by a Circuit Breaker<sup>Ⓛ③</sup>

Breaker Frame	Non-Fused Switch	UL Listed Short Circuit Current Rating
NEG, NGB, ED4	30 DT (240V)	18 kA Thru 240 VAC
NEB, NEG, NGG, NGB, ED4	100A GD & DT (240V)	18 kA Thru 240 VAC
NEB, NEG, NGG, NGB, ED4	30-100A HD & DT (600V)	18 kA Thru 480 VAC
ED6	30-100A HD & DT (600V)	18 kA Thru 600 VAC
FD6-A, JD6-A	200A HD & DT (600V)	18 kA Thru 600 VAC
JD6-A, LD6-A	400A GD & DT (240V)	18 kA Thru 240 VAC
JD6-A, LD6-A	400A HD & DT (600V)	18 kA Thru 600 VAC
LD6-A	600A GD & DT (240V)	25kA Thru 240 VAC
LD6-A	600A HD & DT (600V)	25kA Thru 600 VAC
NNG	1200A HD & DT (600V)	25 kA Thru 600 VAC

Ⓛ VBII Type 12 switches are also rated 3R & 3S for outdoor use. Type 3R is defined in B above. 3S rated enclosures provide a degree of protection against windblown dust and allow operation when the enclosure is ice laden.

② All switches above are rated at 10 kA when protected by any UL Listed CB

③ Circuit breaker trip rating must not exceed switch ampere rating

# Catalog Numbering System

## Type VBII Safety Switch Catalog Numbering System

## Product Overview

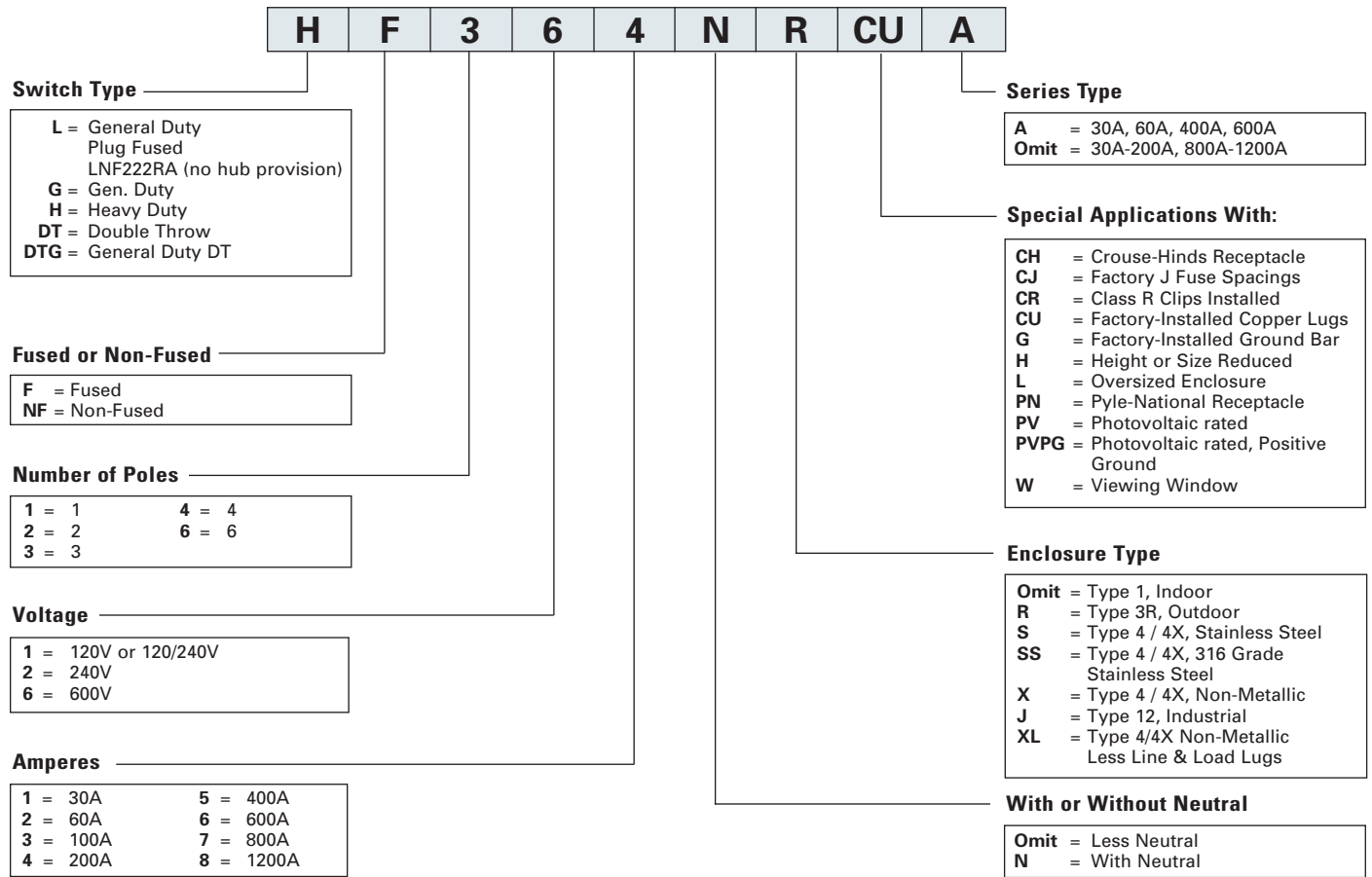

## Type VBII Accessories Catalog Numbering System

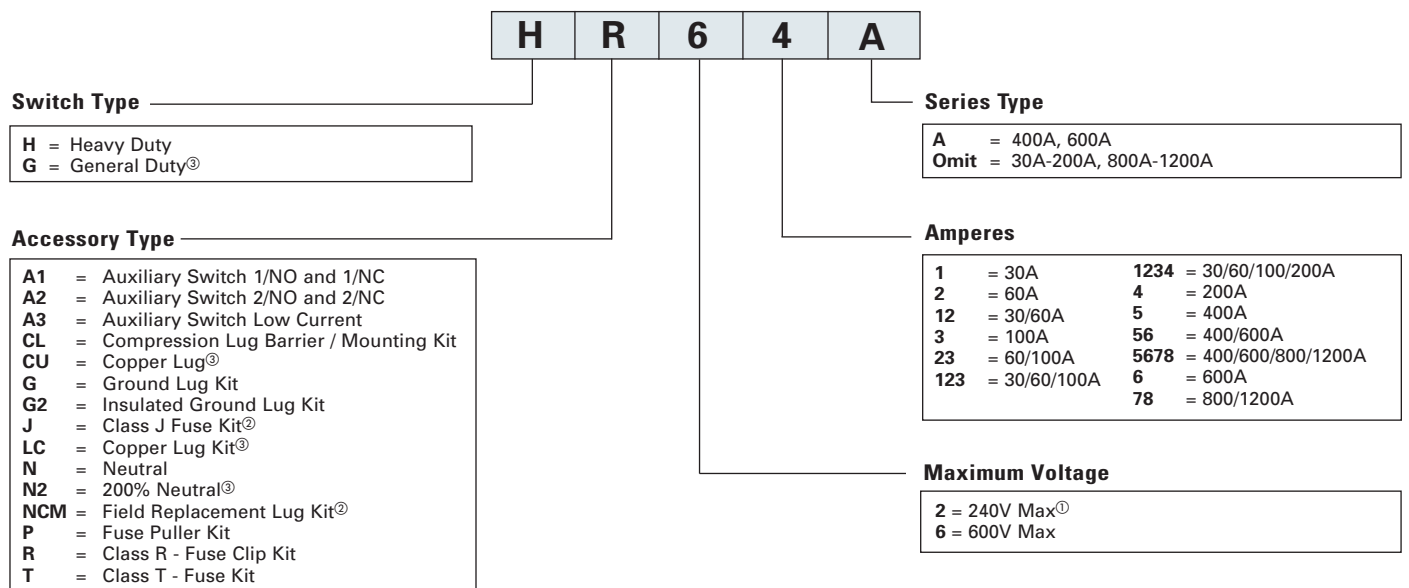

Note: Catalog numbering systems above do not apply to 4-pole & Type "F" & "FR" double throw switches & accessories.

① For 400A, 600A use 680V max accessories except for T Fuse Kit.  
② Only offered for 400A, 600A.

③ For 30A-200A, 800A-1200A.

# General Duty Enclosed Switches

Plug Fuse and 60A Special Application Type

Selection

## Features

- Compact size
- Horsepower rated
- Indoor and outdoor enclosures
- Quick make-quick break mechanism
- Visible "ON"-"OFF" indications
- Padlock-off handle feature
- Door padlock provision
- Bondable neutral (where indicated)
- Lugs suitable for copper or aluminum wire
- UL Listed
- Fuses — not included
- Switches accept Edison base plug fuses
- Hubs — see page 4-22
- Lugs — see page 4-22



## Dimensions (inches)

Type	Height	Width	Depth
1	8 1/4	5 1/2	3
3R	8 1/4	5 1/2	3 1/2

## Wire Range Table

Switch Type	Wire Range
120/240 Volt Fusible 30 Amp	Cu/Al #14 to #8 AWG <sup>ⓐ</sup>
240 Volt Non-Fusible 60 Amp	Cu #14 to #6 AWG

Ampere Rating	Indoor — Type 1		Outdoor — Type 3R		Horsepower Ratings <sup>ⓑ</sup>	
	Catalog Number	Ship. Wt. (lbs.) Pkg. of 10	Catalog Number	Ship. Wt. (lbs.) Pkg. of 10	1-Phase, 2-Wire	
					Standard	Maximum

## 120/240 Volt Fusible

### 1-Pole and Solid Neutral<sup>ⓐ</sup>

### 120 Volt — 1-Phase, 2-Wire

30	LF111N	35	LF111NR	35	1/2	2
----	--------	----	---------	----	-----	---

### 2-Pole and No Neutral

### 120/240 Volt — 1-Phase, 2-Wire

30	Use 2-Pole and Solid Neutral				
----	------------------------------	--	--	--	--

### 2-Pole and Solid Neutral<sup>ⓐ</sup>

### 120/240 Volt — 1-Phase, 3-Wire

30	LF211N	35	LF211NR	35	1 1/2	3
----	--------	----	---------	----	-------	---

## 240 Volt Non-Fusible

### 2-Pole Special Application Switch

### 1 or 2-Pole — No Fuse

### 240 Volt — 1-Phase, 2-Wire

30	—	—	LNF221RLA <sup>ⓐ</sup>	30	—	3
60	—	—	LNF222RA <sup>ⓐ</sup>	30	—	10
60	—	—	LNF222RL <sup>ⓐ</sup>	40	3	10

For inches / millimeters conversion, multiply inches by 25.4.

<sup>ⓐ</sup>Dual horsepower ratings:

Std. — applies when non-time delay plug fuses are installed.

Max — applies when time-delay plug fuses are installed.

<sup>ⓑ</sup>Has service entrance label.

UL Listed as "Enclosed Switches" (suitable for use as service equipment where indicated) under File #E4776. (NEMA) — Type G.D.

Federal Spec. — W-S-865C — type LD or type NDS

<sup>ⓐ</sup>Bottom cable entry and exit only. No hub provision supplied. Ground lug is included and factory installed.

<sup>ⓑ</sup>Line lugs will accept and are UL approved for #14 to #6 Cu/Al cable.

<sup>ⓐ</sup>Legacy style, oversize enclosure. Ground lug is included and factory installed.

# General Duty Safety Switches

Features (60-600A)

Product Overview

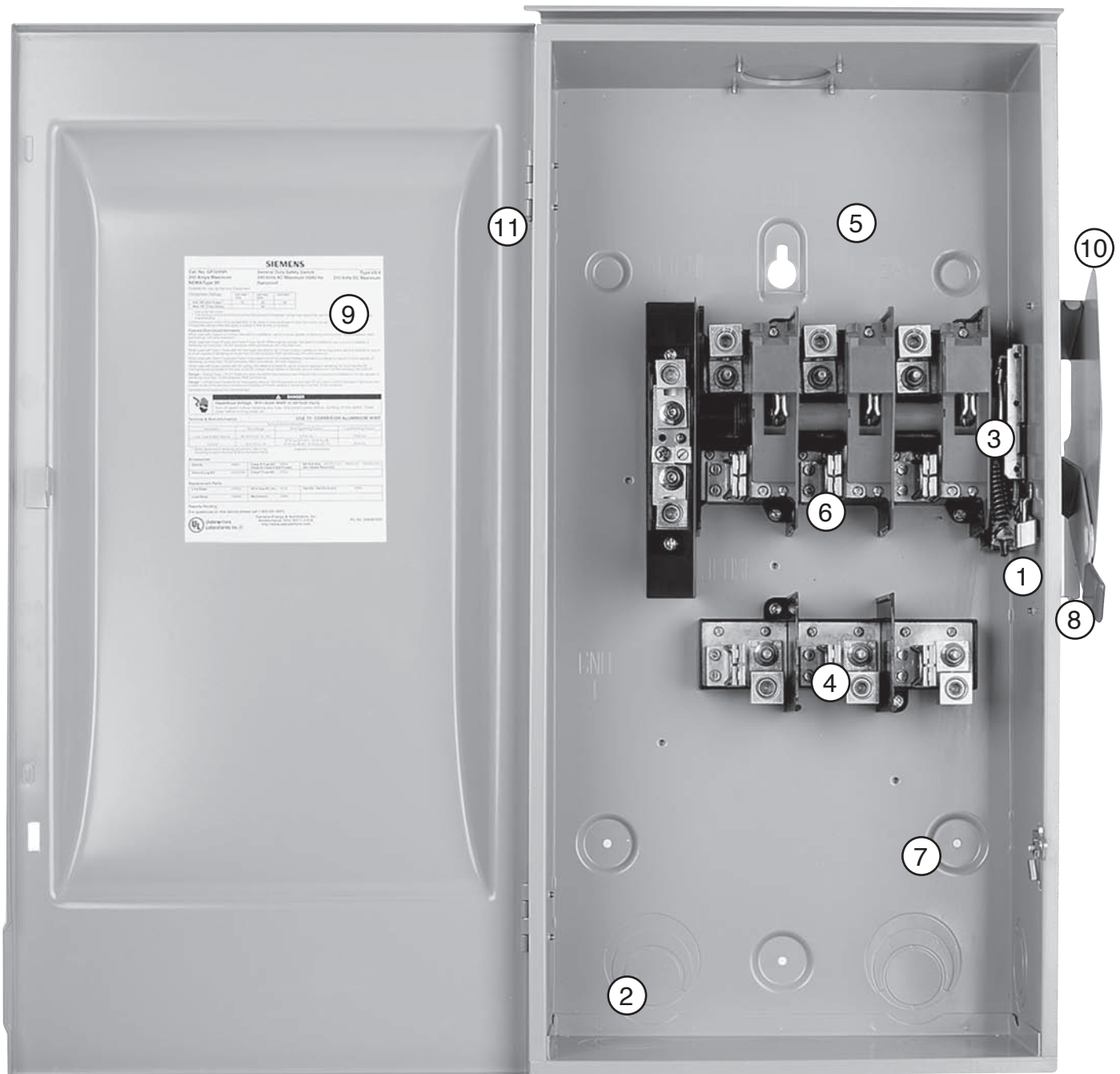
**4**  
SAFETY  
SWITCHES

1. Cover interlock
  2. Tangential knockouts 100-600A for easy conduit lineup
  3. Quick-make, quick-break operating mechanism that ensures positive operation
  4. Provisions for T, R, J, H, and K class fuses (T & J 100-600A)
  5. Wiring gutters that meet or exceed NEC wire-bending space requirements
  6. Visible blade, double-break switch action
  7. Positive 2 or 3 point mounting
  8. Highly visible red handle grip
  9. Informative door labeling which includes replacement parts list
  10. Handle and cover padlocking provisions
  11. 100A and above have side-hinged door that opens 180 degrees for easier wiring
- Note.** 400A and 600A GD switches include internal shields which meet 2020 NEC 230.62 touch safe requirements for service entrance equipment.

# General Duty Safety Switches

Selection

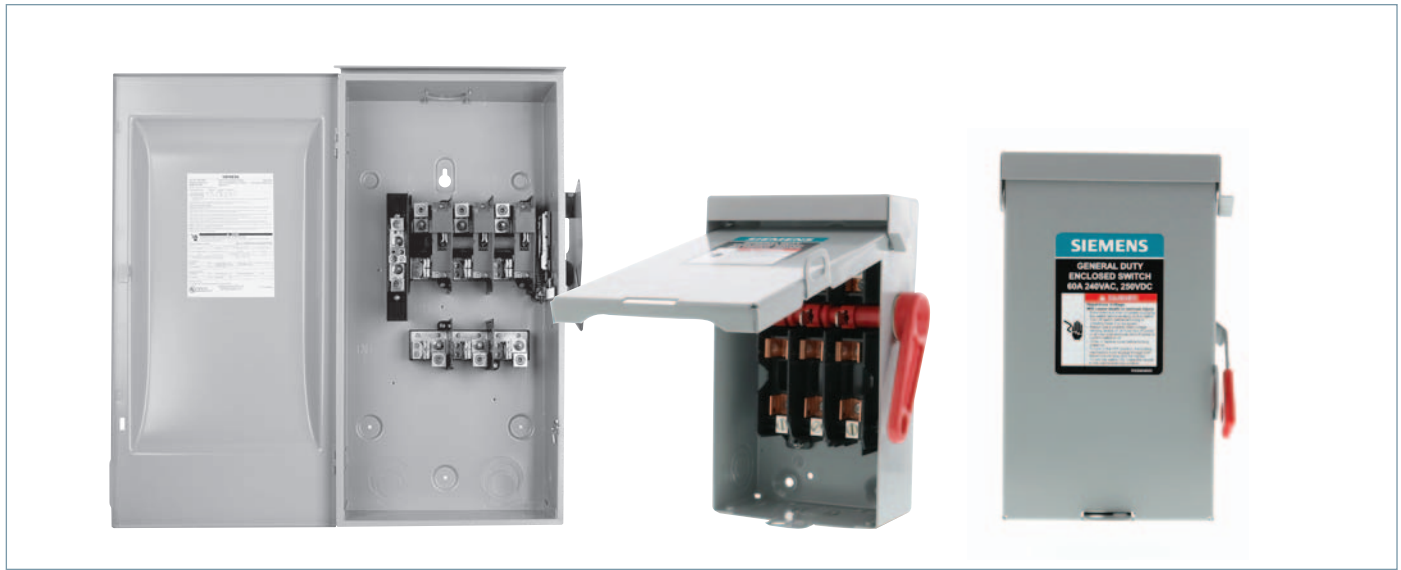

4 SAFETY SWITCHES

System	Ampere Rating	Indoor — Type 1		Outdoor — Type 3R		Horsepower Rating <sup>①</sup>						
		Catalog Number	Ship Wt. (lbs.) Std. Pkg	Catalog Number	Ship Wt. (lbs.) Std. Pkg	240V AC		250 Volt DC				
						1-Phase, 2-Wire	2-Phase, 4-Wire	3-Phase, 3-Wire	Std.	Max.	Std.	Max.

## 240 Volt Fusible<sup>①</sup>

### 2-Pole, 2-Fuse, and Solid Neutral<sup>②③④</sup>

### 240 Volt AC/250 Volt DC

	30	GF221NA	30 <sup>⑦</sup>	GF221NRA <sup>⑤</sup>	30 <sup>⑦</sup>	1½	3	—	—	3	7½	5
	60	GF222NA	20 <sup>⑥</sup>	GF222NRA <sup>⑤</sup>	20 <sup>⑥</sup>	3	10	—	—	7½	15	10
	100	GF223N	23	GF223NR	23	7½	15	—	—	15	30	20
	200	GF224N	47	GF224NR	48	15	—	—	—	25	60	40

### 3-Pole, 3-Fuse, and Solid Neutral<sup>④</sup>

### 240 Volt AC/250 Volt DC

	30	GF321NA	30 <sup>⑦</sup>	GF321NRA <sup>⑤</sup>	30 <sup>⑦</sup>	1½	3	—	—	3	7½	5
	60	GF322NA	20 <sup>⑥</sup>	GF322NRA <sup>⑤</sup>	20 <sup>⑥</sup>	3	10	—	—	7½	15	10
	100	GF323N	25	GF323NR	25	7½	15	—	—	15	30	20
	200	GF324N	49	GF324NR	50	15	—	—	—	25	60	40
	400	GF325NA	94.6	GF325NRA	94.6	15	—	—	—	50	125	50
	600	GF326NA	95.6	GF326NRA	95.6	15	—	—	—	75	200	—

## 240 Volt Non-Fusible<sup>③④⑩</sup>

### 2-Pole or 3-Pole

### 240 Volt AC/250 Volt DC

	30	GNF221A	20 <sup>⑦</sup>	GNF221RA <sup>⑤</sup>	20 <sup>⑦</sup>	—	3	—	—	—	—	5
	30	GNF221LA <sup>⑧</sup>	30 <sup>⑦</sup>	GNF221RLA <sup>⑤⑨</sup>	30 <sup>⑦</sup>	—	3	—	—	—	—	5
	30	GNF321A <sup>⑤</sup>	20 <sup>⑦</sup>	GNF321RA <sup>⑤⑥</sup>	20 <sup>⑦</sup>	—	3	—	—	7½	—	5
	30	GNF321LA <sup>⑧</sup>	30 <sup>⑦</sup>	GNF321RLA <sup>⑤⑩</sup>	30 <sup>⑦</sup>	—	3	—	—	7½	—	5
	60	GNF222A	30 <sup>⑦</sup>	GNF222RA <sup>⑤</sup>	30 <sup>⑦</sup>	—	10	—	—	15	—	10
	60	GNF322A	30 <sup>⑦</sup>	GNF322RA <sup>⑤</sup>	30 <sup>⑦</sup>	—	10	—	—	15	—	10
	100	GNF323	23	GNF323R	24	—	15	—	—	30	—	20
	200	GNF324	46	GNF324R	47	—	15	—	—	60	—	40
	400	GNF325A	114	Use 600V Switch — HNF365RA	—	—	15	—	—	125	—	50
	600	GNF326A	116	Use 600V Switch — HNF366RA	—	—	15	—	—	200	—	—

① Dual horsepower ratings: Std.- applies when non-time delay fuses are installed. Max.- applies when time-delay fuses are installed.  
 ② These switches are UL-listed for application on grounded B-phase systems.  
 ③ Suitable for use on 3-phase motor loads.

④ Service entrance labeled.  
 ⑤ Has provision for ECHA type hub.  
 ⑥ 5 switches per standard package.  
 ⑦ 10 switches per standard package.  
 ⑧ Height reduced switch (45.25 rather than 56 inches in height) for use with 500MCM or smaller conductors.

⑨ Not suitable for service entrance.  
 ⑩ "L" in catalog number indicates oversized enclosure.  
 ⑪ Internal shields for 30A to 200A switches to meet 2020 NEC 230.62 touch safe requirements for service entrance equipment can be purchased separately. See accessory section for catalog numbers.

# Heavy Duty Safety Switches

Features

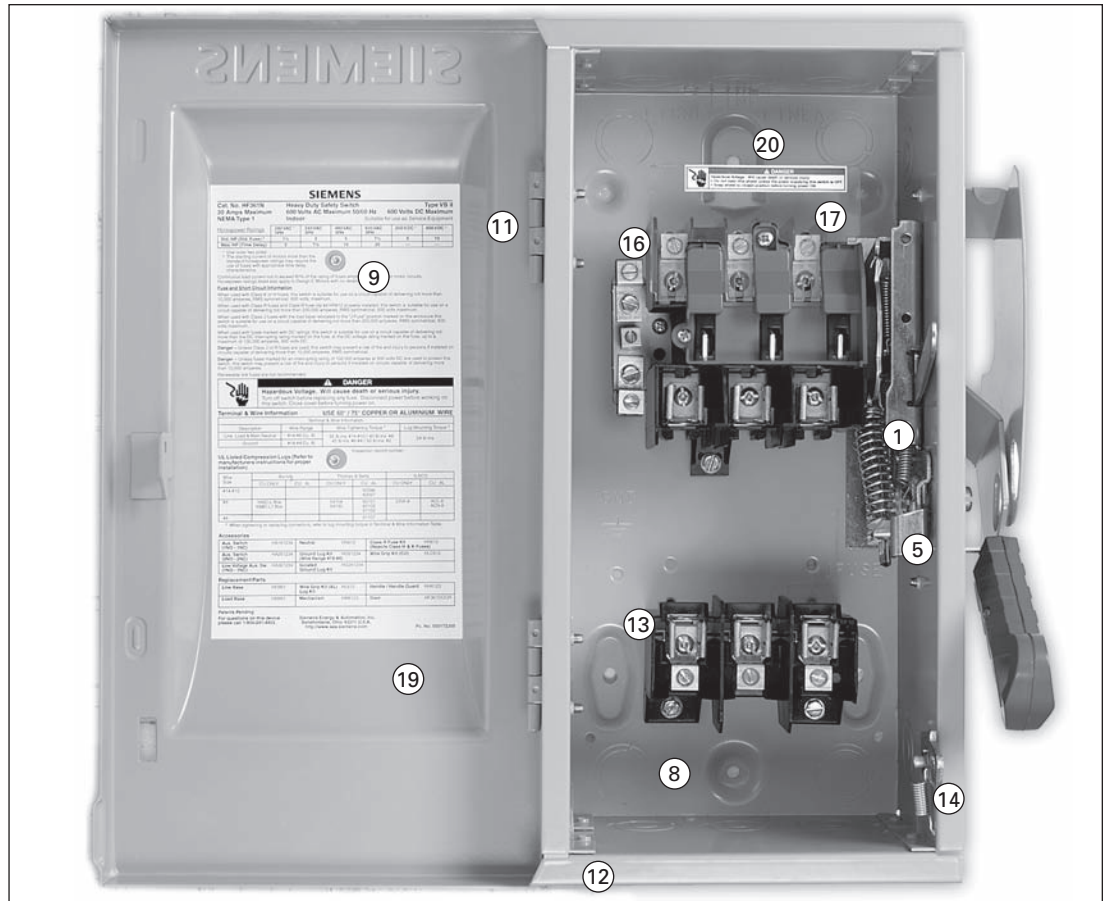
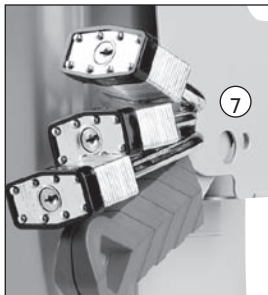
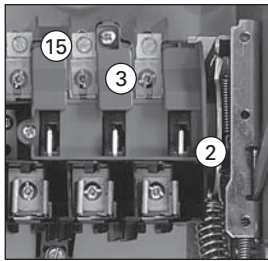

1. Quick-make, quick-break operating mechanism that ensures positive operation.
2. Visible blade, double-break switching action.
3. Arc chutes dissipate heat and prolong switch life.
4. Highly visible red handle grip. Designed for hook stick operation.
5. Defeatable dual cover interlock.
6. Center punch provided for field drilling to allow ON padlocking.
7. Handle can be padlocked in the OFF position with up to (3) padlocks with 5/16" hasps.
8. Generous top, bottom and side gutters that meet or exceed NEC wire-bending space requirements.
9. Informative door labeling which includes replacement parts list.
10. Tangential knockouts through 600A for easy conduit lineup.
11. Side-hinged door that opens past 180 degrees for easier wiring.
12. Unique enclosure design increases rigidity and prevents cuts and scrapes to conductors and installer's hands.
13. Spring reinforced fuse clips that assure reliable contact for cool operation.
14. Door latch securely holds door closed and allows cover padlocking.
15. Front removable mechanical lugs that are suitable for CU/Al 60 or 75° C conductors.
16. Lugs are field convertible to copper body and to a wide variety of compression connectors.
17. Hinged clear line terminal shield with probe holes for inspecting or testing line side terminals.  
All HD switches include internal shields which meet 2020 NEC 230.62 touch safe requirements for service entrance equipment.
18. Embossed aluminum nameplate on Heavy Duty Switches provides highly visible ON/OFF indication.
19. Drawn cover for increased rigidity and resistance to abuse.
20. Top key hole and bottom mounting holes provide easy 2 or 3 point mounting.

# Heavy Duty Safety Switches

Selection



4 SAFETY SWITCHES

System	Ampere Rating	Indoor — Type 1		Outdoor — Type 3R		Horsepower Rating <sup>①</sup>						
		Catalog Number	Ship Wt. (lbs.) Std. Pkg	Catalog Number	Ship Wt. (lbs.) Std. Pkg	240V AC		250 Volt DC				
						1-Phase, 2-Wire	2-Phase, 4-Wire	3-Phase, 3-Wire	Std.	Max.	Std.	Max.
<b>240 Volt Fusible<sup>⑤</sup></b>												
<b>2-Pole, 2-Fuse, and Solid Neutral<sup>③</sup> (Also used for 2-Pole, 2-Wire Applications) 240 Volt AC/250 Volt DC</b>												
	30	HF221N	12	HF221NR	13	1½	3	—	—	3	7½	5
	60	HF222N	18	HF222NR	19	3	10	—	—	7½	15	10
	100	HF223N	23	HF223NR	24	7½	15	—	—	15	30	20
	200	HF224N	47	HF224NR	48	15	—	—	—	25	60	40
	400	HF225NA	91.1	HF225NRA	91.1	15	—	—	—	50	125	50
	600	HF226NA	95.6	HF226NRA	95.6	15	—	—	—	75	200	50
	800	HF227N	365	HF227NR	365	—	—	—	—	100	250	50
	1200	HF228N■	385	HF228NR■	385	—	—	—	—	100	250	50
<b>3-Pole, 3-Fuse, and Solid Neutral (Also used for 3-Pole, 3-Wire Applications) 240 Volt AC/250 Volt DC</b>												
	30	HF321N	14	HF321NR	15	1½	3	—	—	3	7½	5
	60	HF322N	19	HF322NR	20	3	10	—	—	7½	15	10
	100	HF323N	25	HF323NR	26	7½	15	—	—	15	30	20
	200	HF324N	49	HF324NR	50	15	—	—	—	25	60	40
	400	HF325NA	94.6	HF325NRA	94.6	15	—	—	—	50	125	50
	600	HF326NA	99.6	HF326NRA	99.6	15	—	—	—	75	200	50
	800	HF327N	375	HF327NR	375	—	—	—	—	100	250	50
	1200	HF328N	395	HF328NR	388	—	—	—	—	100	250	50
<b>240 Volt Fusible<sup>⑤</sup></b>												
<b>2-Pole, 2-Fuse<sup>④</sup> 240 Volt AC/250 Volt DC</b>												
		Type 4/4X Stainless <sup>②</sup>		Type 12 Industrial <sup>②</sup>								
	30	HF221S	13	HF221J	13	1½	3	—	—	3	7½	5
	60	HF222S	19	HF222J	19	3	10	—	—	7½	15	10
	100	HF223S	24	HF223J	24	7½	15	—	—	15	30	20
	200	HF224S	48	HF224J	48	15	—	—	—	25	60	40
<b>3-Pole, 3-Fuse<sup>④</sup> (Also used for 2-Pole, 2-Wire Applications in 400–800A Ratings) 240 Volt AC/250 Volt DC</b>												
	30	HF321S	14	HF321J	14	1½	3	—	—	3	7½	—
	60	HF322S	20	HF322J	20	3	10	—	—	7½	15	10
	100	HF323S	25	HF323J	25	7½	15	—	—	15	30	20
	200	HF324S	49	HF324J	49	15	—	—	—	25	60	40
	400	HF325SA	93	HF325JA	93	15	—	—	—	50	125	50
	600	HF326SA	98	HF326JA	98	15	—	—	—	75	200	50
	800	HF327S■	370	HF327J■	365	—	—	—	—	100	250	50

■ Built to order. Allow 3-5 weeks for delivery.  
 ① Height reduced switch (45.25 inches rather than 56 inches in height) for use with 500MCM or smaller conductors.  
 ② Dual horsepower ratings: Std.- applies when non-time delay fuses are installed. Max.- applies when time-delay fuses are installed.

③ These switches are UL-listed for application on grounded B-phase systems and are suitable for 3-phase motor applications.  
 ④ When a neutral is required use a field installed neutral kit.

⑤ Suitable for use as service entrance equipment.  
 ⑥ Also rated Type 3S/3R.  
 ⑦ 304 grade stainless steel. For switches with enclosures constructed from 316 grade stainless steel, substitute "SS" in catalog number for "S."

# Heavy Duty Safety Switches

Selection



System	Ampere Rating	Indoor — Type 1		Outdoor — Type 3R		Horsepower Rating <sup>Ⓞ</sup>									
		Catalog Number	Ship Wt. (lbs.) Std. Pkg	Catalog Number	Ship Wt. (lbs.) Std. Pkg	480V AC				600V AC				250 Volt DC	600 Volt DC
						1-Phase, 2-Wire		3-Phase, 3-Wire		1-Phase, 2-Wire		3-Phase, 3-Wire			
Std.	Max.	Std.	Max.	Std.	Max.	Std.	Max.	Std.	Max.	Std.	Max.	Std.	Max.		

## 600 Volt Fusible<sup>Ⓞ</sup>

### 2-Pole, 2-Fuse<sup>Ⓞ</sup>

						480 Volt AC/600 Volt AC/600 Volt DC									
	30	HF261	15	HF261R	15	3	7½	—	—	3	10	—	—	5	15
	60	HF262	20	HF262R	20	5	20	—	—	10	25	—	—	10	30
	100	HF263	26	HF263R	27	10	30	—	—	15	40	—	—	20	50

### 3-Pole, 3-Fuse

						480 Volt AC/600 Volt AC/250 Volt DC <sup>①</sup>									
	30	HF361	14	HF361R	15	3	7½	5	15	3	10	7½	20	5	—
	30	HF361L <sup>②</sup>	19	HF361RL <sup>②</sup>	20	3	7½	5	15	3	10	7½	20	5	—
	60	HF362	19	HF362R	20	5	20	15	30	10	25	15	50	10	30 <sup>Ⓞ</sup>
	60	—	—	HF362RL <sup>②</sup>	25	5	20	15	30	10	25	15	50	10	30 <sup>Ⓞ</sup>
	100	HF363	24	HF363R	25	5	20	25	60	15	40	30	75	20	50 <sup>Ⓞ</sup>
	200	HF364	48	HF364R	49	25	50	50	125	30	50	60	150	40	50
	400	HF365A <sup>①</sup>	93	HF365RA <sup>①</sup>	157	—	—	100	250	—	—	125	350	50	—
	600	HF366A <sup>①</sup>	98	HF366RA <sup>①</sup>	161	—	—	150	400	—	—	200	500	50	—
	800	HF367	365	HF367R	365	—	—	200	500	—	—	250	500	50	—
1200	HF368	383	HF368R	385	—	—	200	500	—	—	250	500	50	—	

### 3-Pole, 3-Fuse and Solid Neutral

						480 Volt AC/600 Volt AC/250 Volt DC <sup>①</sup>									
	30	HF361N	14	HF361NR	15	3	7½	5	15	3	10	7½	20	5	—
	60	HF362N	19	HF362NR	20	5	20	15	30	10	25	15	50	10	30 <sup>Ⓞ</sup>
	100	HF363N	25	HF363NR	26	10	30	25	60	15	40	30	75	20	50 <sup>Ⓞ</sup>
	200	HF364N	49	HF364NR	50	25	50	50	125	30	50	60	150	40	50
	400	HF365NA	94.6	HF365NRA	94.6	—	—	100	250	—	—	125	350	50	—
	600	HF366NA	99.6	HF366NRA	99.6	—	—	150	400	—	—	200	500	50	—
	800	HF367N	375	HF367NR	375	—	—	250	500	—	—	250	500	50	—
	1200	HF368N	395	HF368NR	388	—	—	250	500	—	—	250	500	50	—

## 600 Volt Fusible<sup>Ⓞ</sup> (For 2-Pole Applications use outside poles of 3-Pole Switches)

### 2-Pole, 2-Fuse<sup>Ⓞ</sup>

						480 Volt AC/600 Volt AC/600 Volt DC									
	30	Type 4/4X Stainless <sup>Ⓞ</sup>		Type 12 Industrial <sup>Ⓞ</sup>		3	7½	—	—	3	10	—	—	5	15
		HF261S	15	HF261J■	15										
		HF262S	20	HF262J■	20										
	100	HF263S■	27	HF263J■	27	10	30	—	—	15	40	—	—	20	50

### 3-Pole, 3-Fuse

						480 Volt AC/600 Volt AC/250 Volt DC <sup>①</sup>									
	30	HF361S	13	HF361J	14	—	—	5	15	—	—	7½	20	5	—
	60	HF362S	20	HF362J	20	—	—	15	30	—	—	15	50	10	30 <sup>Ⓞ</sup>
	100	HF363S	25	HF363J	25	—	—	25	60	—	—	30	75	20	50 <sup>Ⓞ</sup>
	200	HF364S	49	HF364J	49	—	—	50	125	—	—	60	150	40	50
	400	HF365SA <sup>①</sup>	93	HF365JA <sup>①</sup>	93	—	—	100	250	—	—	125	350	50	—
	600	HF366SA <sup>①</sup>	98	HF366JA <sup>①</sup>	98	—	—	150	400	—	—	200	500	50	—
	800	HF367S	370	HF367J■	365	—	—	200	500	—	—	250	500	50	—
	1200	HF368S■	388	HF368J■	388	—	—	250	500	—	—	250	500	50	—

■ Built to order. Allow 3-5 weeks for delivery.

① 60-600A 3-Pole switches are also rated 600V DC.

② Height reduced switch (45.25 rather than 56 inches in height) for use with 500MCM or smaller conductors.

③ Use 3-Pole switch for 200A applications.

④ Dual horsepower ratings: Std.- applies when non-time delay fuses are installed. Max.- applies when time-

delay fuses are installed.

⑤ Suitable for use as service entrance equipment except on 1200 Amp solidly grounded wye systems per NEC 230.95.

⑥ Also rated Type 3S/3R.

⑦ Indicates oversized enclosure (30A switch with 60A lugs in a 60A enclosure or 60A switch with 100A lugs in a 100A enclosure).

⑧ 600V DC & 600V DC horsepower rating shown requires (2) poles to be connected in series.

⑨ 304 grade stainless steel. For switches with enclosures constructed from 316 grade stainless steel, substitute "SS" in catalog number for "S."

# Heavy Duty Safety Switches

Selection



4 SAFETY SWITCHES

System	Ampere Rating	Indoor — Type 1		Outdoor — Type 3R		Horsepower Rating							
		Catalog Number	Ship Wt. (lbs.)	Catalog Number	Ship Wt. (lbs.)	240 Volt		480 Volt		600 Volt		250V DC	600V DC
						1-Phase	3-Phase	1-Phase	3-Phase	1-Phase	3-Phase		

## 600 Volt Non-Fusible<sup>④</sup>

### 2-Pole<sup>③</sup>

						480 Volt AC / 600 Volt AC / 600 Volt DC							
	30	HNF261	12	HNF261R	13	—	—	7½	—	10	—	5	15
	60	HNF262	19	HNF262R	20	—	—	20	—	25	—	10	30
	100	HNF263	24	HNF263R	25	—	—	30	—	40	—	20	50

### 3-Pole

						480 Volt AC / 600 Volt AC / 250 Volt DC							
	30	HNF361	12	HNF361R	13	5	10	7½	20	10	30	5	—
	30	—	—	HNF361RL <sup>②</sup>	19	5	10	7½	20	10	30	5	—
	60	HNF362H <sup>②</sup>	11	HNF362RH <sup>②</sup>	11	10	20	20	50	20	40	10	—
	60	HNF362 <sup>①</sup>	18	HNF362R <sup>①</sup>	19	10	20	20	50	25	60	10	30 <sup>②</sup>
	60	—	—	HNF362RL <sup>②</sup>	24	10	20	20	50	25	60	10	30 <sup>②</sup>
	100	HNF363 <sup>①</sup>	23	HNF363R <sup>①</sup>	24	15	40	30	75	40	100	20	50 <sup>②</sup>
	200	HNF364 <sup>①</sup>	46	HNF364R <sup>①</sup>	47	15	60	50	125	50	150	40	50
	400	HNF365A <sup>①</sup>	75	HNF365RA <sup>①</sup>	75	15	125	50	250	50	350	50	—
	600	HNF366A <sup>①</sup>	77	HNF366RA <sup>①</sup>	77	15	200	50	400	50	500	50	—
	800	HNF367	295	HNF367R	295	15	250	50	500	50	500	50	—
1200	HNF368	305	HNF368R	307	15	250	50	500	50	500	50	—	

## 600 Volt Non-Fusible<sup>④</sup>

### 2-Pole<sup>③</sup>

						480 Volt AC / 600 Volt AC / 600 Volt DC							
		Type 4 / 4X Stainless <sup>⑥</sup>	Type 12 Industrial <sup>⑤</sup>										
	30	HNF261S	13	HNF261J	13	—	—	7½	—	10	—	5	15
	60	HNF262S	20	HNF262J	20	—	—	20	—	25	—	10	30
	100	HNF263S■	25	HNF263J■	25	—	—	30	—	40	—	20	50

### 3-Pole

						480 Volt AC / 600 Volt AC / 250 Volt DC							
	30	HNF361S	13	HNF361J	13	5	10	7½	20	10	30	5	—
	60	HNF362SH <sup>②</sup>	15	HNF362JH <sup>②</sup>	14	10	20	20	50	20	40	10	—
	60	HNF362S <sup>①</sup>	19	HNF362J <sup>①</sup>	19	10	20	20	50	25	60	10	30 <sup>②</sup>
	100	HNF363S <sup>①</sup>	24	HNF363J <sup>①</sup>	24	15	40	30	75	40	100	20	50 <sup>②</sup>
	200	HNF364S <sup>①</sup>	47	HNF364J <sup>①</sup>	47	15	60	50	125	50	150	40	50
	400	HNF365SA <sup>①</sup>	75	HNF365JA <sup>①</sup>	75	15	125	50	250	50	350	50	—
	600	HNF366SA <sup>①</sup>	77	HNF366JA <sup>①</sup>	77	15	200	50	400	50	500	50	—
	800	HNF367S	295	HNF367J■	295	15	250	50	500	50	500	50	—
	1200	HNF368S■	310	HNF368J■	310	15	250	50	500	50	500	50	—

■ Built to order. Allow 3-5 weeks for delivery.

① 60-600A 3-Pole switches are also rated 600V DC.

② Compact switch (11.1"H, 6.6"W box less cover and handle).

③ Short circuit withstand rating—100,000 RMS sym. amps.

④ Use 3-Pole switch for 200A application.

⑤ Suitable for use as service entrance equipment except for

1200 when used on a 480 or 600V grounded wye system.

⑥ Also rated type 3S / 3R.

⑦ Indicates oversized enclosure (30A switch in a 60A enclosure or a 60A switch in a 100A enclosure).

⑧ 600V DC and 600V DC horsepower rating shown

requires (2) poles to be connected in series.

⑨ 304 grade stainless steel. For switches with enclosures constructed from 316 grade stainless steel, substitute "SS" in catalog number for "S."

# Heavy Duty Safety Switches

## Safety Switches with Viewing Window

Selection

### Description

30–600A, 3-pole 600V max. in fusible and non-fusible versions in Type 4/4X stainless steel, and Type 12, and select 3R enclosures.

All allow viewing of visible blade position with the door closed. 30–200A also allow viewing of indicating type fuses.

### Features

- Rugged installer-friendly enclosure design features a gasket flange with continuously welded seams
- Tool-free cover latches

- Two, three and four point mounting
- Metal handle with large insulating grip features a positive stop in both ON and OFF position
- Ground lugs provided as standard in Type 12 and 4X switches
- Type 12 enclosures are fabricated from galvanized steel and are also rated for 3R/3S outdoor applications
- Type 4X stainless steel switches (30–200A) are provided with stainless steel interior parts
- The widest range of accessories available including 200% neutrals, gold plated PLC auxiliary contacts and isolated ground kits



System	Ampere Rating	Catalog Number	Ship Wt. (lbs.)	Maximum Horsepower Rating <sup>②</sup>					
				240V AC		480V AC	600V AC	250V DC	600V DC
				1-Phase, 2-Wire	3-Phase	3-Phase	3-Phase		
<b>3-Pole, 3-Wire Fusible, Type 3R<sup>④</sup></b>				<b>600 Volt AC / 250 Volt DC<sup>①</sup></b>					
	30	HF361RW	17	3	7½	15	20	5	—
	60	HF362RW	22	10	15	30	50	10	30 <sup>⑤</sup>
	800	HF367NRW	375	—	—	500	500	50	—
	1200	HF368NRW	388	—	—	500	500	50	—
<b>3-Pole, 3-Wire Non-Fusible, Type 3R<sup>④</sup></b>				<b>600 Volt AC / 250 Volt DC<sup>①</sup></b>					
	30	HNF361RW	14	3	10	20	30	5	—
	60	HNF362RW	21	10	20	50	60	10	30 <sup>⑤</sup>
	800	HNF367RW	295	15	250	500	500	50	—
	1200	HNF368RW	307	15	250	500	500	50	—
<b>3-Pole, 3-Wire Fusible, Type 12<sup>③④</sup></b>				<b>600 Volt AC / 250 Volt DC<sup>①</sup></b>					
	30	HF361JW	17	3	7½	15	20	5	—
	60	HF362JW	22	10	15	30	50	10	30 <sup>⑤</sup>
	100	HF363JW	26	15	30	60	75	20	50 <sup>⑤</sup>
	200	HF364JW	53	—	60	125	150	40	50
	400	HF365JWA	93	—	125	250	350	50	—
	600	HF366JWA	98	—	200	400	500	50	—
	800	HF367JW	365	—	—	500	500	50	—
	1200	HF368JW	388	—	—	500	500	50	—
<b>3-Pole, 3-Wire Non-Fusible, Type 12<sup>③④</sup></b>				<b>600 Volt AC / 250 Volt DC</b>					
	30	HNF361JW	14	3	10	20	30	5	—
	60	HNF362JW	21	10	20	50	60	10	30 <sup>⑤</sup>
	100	HNF363JW	25	15	40	75	100	20	50 <sup>⑤</sup>
	200	HNF364JW	51	15	60	125	150	40	50
	400	HNF365JWA	75	15	125	250	350	50	—
	600	HNF366JWA	77	15	200	400	500	50	—
	800	HNF367JW	295	15	250	500	500	50	—
	1200	HNF368JW	310	15	250	500	500	50	—
<b>3-Pole, 3-Wire Fusible, Type 4X Stainless Steel<sup>④⑥</sup></b>				<b>600 Volt AC / 250 Volt DC<sup>①</sup></b>					
	30	HF361SW	17	3	7½	15	20	5	—
	60	HF362SW	23	10	15	30	50	10	30 <sup>⑤</sup>
	100	HF363SW	28	15	30	60	75	20	50 <sup>⑤</sup>
	200	HF364SW	55	—	60	125	150	40	50
	400	HF365SWA	75	15	125	250	350	50	—
	600	HF366SW	98	—	—	400	500	50	—
	800	HF367SW	365	—	—	500	500	50	—
	1200	HF368SW	388	—	—	500	500	50	—
<b>3-Pole, 3-Wire Non-Fusible, Type 4X Stainless Steel<sup>④⑥</sup></b>				<b>600 Volt AC / 250 Volt DC<sup>①</sup></b>					
	30	HNF361SW	15	3	10	20	30	5	—
	60	HNF362SW	23	10	20	50	60	10	30 <sup>⑤</sup>
	100	HNF363SW	27	15	40	75	100	20	50 <sup>⑤</sup>
	200	HNF364SW	54	15	60	125	150	40	50
	400	HNF365SWA	75	15	125	250	350	50	—
	800	HNF367SW	295	15	250	500	500	50	—
	1200	HNF368SW	310	15	250	500	500	50	—

① 200A switches are also rated 600V DC.

② Maximum HP ratings listed apply only when time delay fuses are used.

③ Also rated 3S/3R for outdoor use.

④ All switches are suitable for use as service entrance equipment.

⑤ 600V DC and 600V DC horsepower rating shown requires (2) poles to be connected in series.

⑥ 304 grade stainless steel. For switches with enclosures constructed from 316 grade stainless steel, substitute "SS" in catalog number for "S."

# Heavy Duty Safety Switches

Type ECS Elevator Control Switches

Catalog Logic

## Elevator Control Switches

### Application

Siemens Type (ECS) Elevator Control disconnect switches are designed for single cable or hydraulic elevator application to interrupt the incoming AC power upon receiving a signal from the Fire Alarm Control Panel (FACP).

### Description

The Elevator Control switch units come completely assembled for quick installation, eliminating the labor and time needed to assemble individual components. Therefore, the numbering system assures that you get all of the correct components, assembled with the correct ratings, without having to individually order accessories.

It is easy to meet Code requirements for selective coordination in a fully fused system. Siemens Type (ECS) Elevator Control disconnect switches utilize Class J fuses that easily coordinate with any upstream fuse by simply using a 2:1 line-side to load-side fuse ratio.

### Standards

- UL 98 Enclosed and Dead Front Switch – Guide 96NK3917, File E182262



### Catalog Number System

The following catalog numbering system defines an Elevator Control Switch construction.

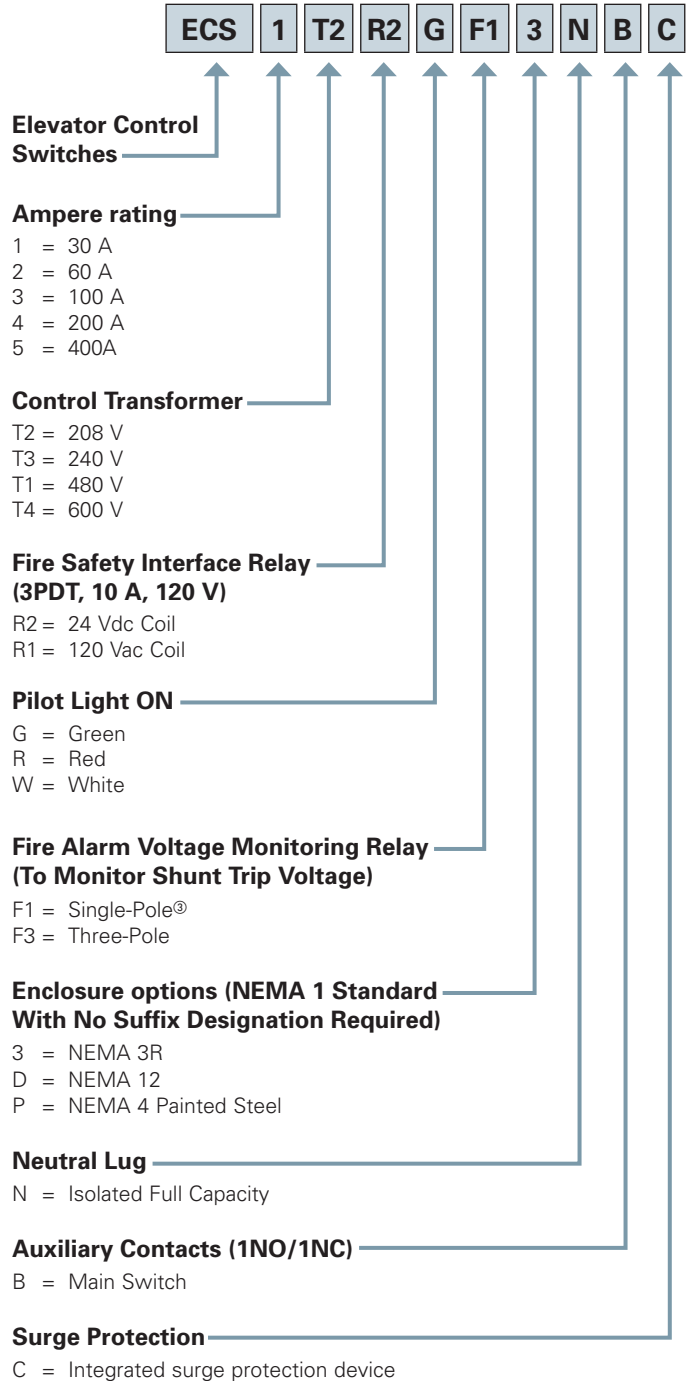

® 100 VA with Primary and Secondary fusing (120 V Secondary)  
 ® For information on Siemens TPS3 03 protection device refer to product literature or Speedfax  
 ® F1 must be selected if 24 Vdc Coil for safety interface relay (R2) is selected

# Heavy Duty Safety Switches

Type ECS Elevator Control Switches

Features

## Elevator Control Switches

### Standard Features

- 30-400 A, 600 Vac, 3-phase fused power switch
- 200 kA RMS assembly short-circuit current rating
- Shunt trip 120 V
- Control power terminal block
- Ground lug compliant with the National Electric Code
- Class J fuse mounting only (Class J fuses not included)
- Key to test switch
- Pilot light – "ON"
- Mechanically interlocked auxiliary contact for hydraulic elevators with battery backup (5 A, 120 Vac rated)
- Handle designed for hook stick operation
- OSHPD Special Seismic Certification Preapproval (OSP)

### Configurable Standard Features

- Control power transformer with fuses and blocks
- Fire safety interface relay
- Isolated neutral lug
- Fire Alarm Voltage Monitoring Relay (to monitor Shunt Trip Voltage)
- NEMA 3R, 4, and 12 enclosures available

### Optional Features

- Oversized 200% rated neutral option available where required by excessive non-linear loads
- Additional auxiliary contact (1NO / 1NC)
- Integrated surge protection device (TPS3 03). Externally viewable through window in door

### Other Options

Optional features include contact closure, i.e. battery lowering/door opening system. The B option offers support for the states of Arizona, Oregon, and Texas requirements to prevent "nuisance" fire alarms by over-riding the "Control Power not Available" signal when the Siemens Elevator control disconnect is manually (intentionally) turned off, and distinctive signaling for ON-OFF-TRIPPED conditions (Option B).

### UL<sub>A</sub> / NEC<sub>B</sub> Listed Horsepower Ratings

Voltage / Poles	30A		60A		100A		200A		400A	
	Std <sup>②</sup>	Max <sup>①</sup>	Std <sup>②</sup>	Max <sup>①</sup>	Std <sup>②</sup>	Max <sup>①</sup>	Std <sup>②</sup>	Max <sup>①</sup>	Std <sup>②</sup>	Max <sup>①</sup>
208VAC / 3 Pole <sub>B</sub>	2	5	5	10	10	15	20	40	40	75
240VAC / 3 Pole <sub>A</sub>	2	7½	7½	15	15	30	25	60	50	75
480VAC / 3 Pole <sub>A</sub>	5	15	15	30	25	60	50	125	100	150
6008VAC / 3 Pole <sub>A</sub>	7½	20	15	50	30	75	60	150	125	200

### Fuse and Short Circuit Information

This switch is suitable for use with Class J Fuses ONLY.

① Max HP with time delay Class J Fuses.  
 ② Max HP with non-time delay Class J Fuses.

All Siemens Elevator Control elevator disconnect switches are UL-Listed and designed for safe access by qualified personnel. When maintenance or shutdown service is required, no energized parts are exposed inside the enclosure when the disconnect switch is manually turned to the OFF position. For proper maintenance safety precautions, always turn off incoming power to the Siemens Elevator Control elevator switch when possible. When servicing any live electrical equipment, always wear appropriate personal protective equipment.

### Shunt-Trip Operation

The disconnect means is a shunt-trip operated switch. The control power source for the shunt-trip operator is a 120 Vac supply originating in the Siemens Elevator Control switch. Current to the shunt-trip device is switched by an isolation relay, which is in turn controlled by the FACP.

The control signal may be either 24 Vdc from the FACP (Option R2) or a "dry" contact closure in the FACP (Option R1). In the case of a "dry" contact closure, the sensing voltage is 120 Vac originating in the Siemens Elevator Control switch.

A key test switch (Option K) is included for testing the shunttrip circuit.

### Supervisory Indication

Additionally, an optional separate relay can be specified to monitor the 120 Vac control power source in the Siemens Elevator Control switch. This relay (Option F1 or F3) is used to provide supervisory indication of "Control Power Available" as required by NFPA 72 Section 6.15.4.4.

### Transformer Fuse Details

ECS Voltage/ Transformer Voltage	Primary Fuse (amps)	Secondary Fuse (amps)
208/120	FNQ-R-2	FNM-1 1/4
240/120	FNQ-R-2	FNM-1 1/4
480/120	FNQ-R-1	FNM-1 1/4
600/120	FNQ-R-1	FNM-1 1/4

# Heavy Duty Safety Switches

## Type VBII 4 & 6-Pole Heavy Duty Safety Switches

Selection

### Application

4 & 6-pole Switches are commonly used as a disconnecting means for two-speed, two-winding motors. Fused switches provide both over current and short circuit protection. Non-fusible switches normally provide a local disconnection means for two-speed motors which are remote from their motor controller. 4-pole switches are also used in 3-phase, 4-wire circuits when a switching neutral is required. All 4 & 6-pole switches are service entrance rated.

### Description

4 & 6-pole switches are available in 30-200A ratings and in both fusible and non-fusible versions. 4-pole switches are supplied with either Type 1 or Type 12/3R enclosures. 6-pole switches are available with either Type 12/3R or Type 4X stainless steel enclosures.

### Standards

- UL & CUL listed under file #E4776
- Meets UL98 for enclosed switches
- 4 & 6-Pole switches are suitable for use as service entrance
- Meets NEMA Standard KS-1 for enclosed switches
- Meets NEC wire bending space requirements

### Features

- Visible blade, double break switching action
- Highly visible ON/OFF indication
- Defeatable dual cover interlock
- Padlock option in OFF position
- All copper current carrying parts<sup>①</sup>
- Tangential knockouts (Type 1, 4-pole switches)



HNF662J

### 4-Pole Type VBII Switches<sup>①②</sup>

System	Amp Rating	Indoor Type 1		Type 12/3R Industrial <sup>③</sup>		Horsepower Ratings <sup>③</sup>				480V, 3Ø		600V, 3Ø		250V DC
		Catalog Number	Ship Wt. (lbs.)	Catalog Number	Ship Wt. (lbs.)	240V, 2Ø, 4W		240V 3Ø		Std.	Max.	Std.	Max.	

#### Fusible 600 Volt AC, 250 Volt DC — 4-Pole, 4 Fuse<sup>④</sup>

	30	HF461	36	HF461J	36	3	10	3	7½	5	15	7½	20	5
	60	HF462	40	HF462J	40	7½	20	7½	15	15	30	15	50	10
	100	HF463	43	HF463J	43	15	30	15	30	25	60	30	75	20
	200	HF464	88	HF464J	88	25	50	25	60	50	125	60	150	40

#### Non-fusible 600 Volt AC, 250 Volt DC — 4-Pole

	30	HNF461	32	HNF461J	32	—	10	—	10	—	20	—	30	5
	60	HNF462	34	HNF462J	34	—	20	—	20	—	50	—	60	10
	100	HNF463	36	HNF463J	36	—	30	—	40	—	75	—	100	20
	200	HNF464	78	HNF464J	78	—	50	—	60	—	125	—	150	4

### 6-Pole Type VBII Switches<sup>①②⑤</sup>

System	Amp Rating	Type 12/3R Industrial		Type 4X Stainless Steel		Horsepower Ratings <sup>③</sup>						250V DC
		Catalog Number	Ship Wt. (lbs.)	Catalog Number	Ship Wt. (lbs.)	240V 3Ø		480V, 3Ø		600V, 3Ø		

#### Fusible 600 Volt AC, 250 Volt DC — 6-Pole, 6 Fuse<sup>④</sup>

	30	HF661J	37	HF661S	37	3	7½	5	15	7½	20	5
	60	HF662J	41	HF662S	41	7½	15	15	30	15	50	10
	100	HF663J	44	HF663S	44	15	30	25	60	30	75	20
	200	HF664J	90	HF664S	90	25	60	50	125	60	150	40

#### Non-fusible 600 Volt AC, 250 Volt DC — 6-Pole

	30	HNF661J	33	HNF661S	33	—	10	—	20	—	30	5
	60	HNF662J	35	HNF662S	35	—	20	—	50	—	60	10
	100	HNF663J	37	HNF663S	37	—	40	—	75	—	100	20
	200	HNF664J	80	HNF664S	80	—	60	—	125	—	150	40

■ Built to order. Allow 3-5 weeks for delivery.

① Lugs are aluminum alloy as standard. Optional copper body lugs are available.

② All 4 & 6-pole VBII switches are suitable for use as service equipment when a neutral is installed or equipment ground kit is properly connected.

③ Dual horsepower ratings: Std. – applies when non-time-delay fuses are installed. Max. – applies when time delay fuses are installed.

④ Fusible switches accept Class H Fuses as the standard. Class R & J fuses can also be installed and increase the rating from 10,000 to 200,000 AIC. For

Class J, the load base is moved upward. For Class R fuses, rejection kits are required.

⑤ Supplied with factory installed ground lugs.

# Heavy Duty Safety Switches

## Application

Receptacle Safety Switches provide cord connection protection of heavy-duty portable equipment (welders, infrared ovens, batch feeders, portable conveyors, assembly line fixtures and tools, refrigerator trucks, etc.) under load or fault conditions.

## Standards

All receptacle switches are UL listed under file #E4776. Those with a viewing window are also CSA certified under file #1079316.

## Description<sup>①②</sup>

Type 12 and 4/4X Receptacle Safety Switches are available with 3-phase, 4-wire grounded type Crouse-Hinds Arkite™ 2 or Pyle-National receptacle, pre-wired and mounted with interlock linkage to the switch mechanism. Insertion or removal of the plug is prevented by the interlock linkage while the switch is in the "ON" position. Receptacle prevents operation of switch if incorrect plug is inserted.



HF362JCH

## Crouse-Hinds Interlocked Receptacle Switches

Ampere Rating <sup>④</sup>	Type 12 <sup>⑤</sup>	Type 4/4X <sup>⑥</sup>	Shipping Wt. (lbs.) Std. Pkg.	Accepts Crouse-Hinds Arkite <sup>®</sup> Plug Catalog Number
	Catalog Number	Catalog Number		

### 240V Fusible, 3-Pole, 3-Wire

30	HF321JCH	HF321SCH▲	23	APJ3485 & NPJ3485
60	HF322JCH	HF322SCH▲	30	APJ6485 & NPJ6485
100	HF323JCH	HF323SCH▲	36	APJ10487 & NPJ10487

### 600V Fusible, 3-Pole, 3-Wire

30	HF361JCH	HF361SCH	24	APJ3485 & NPJ3485
60	HF362JCH	HF362SCH	30	APJ6485 & NPJ6485
100	HF363JCH	HF363SCH▲	36	APJ10487 & NPJ10487

### 600V Non-Fusible, 3-Pole, 3-Wire

30	HNF361JCH▲	HNF361SCH▲	22	APJ3485 & NPJ3485
60	HNF362JCH	HNF362SCH	29	APJ6485 & NPJ6485
100	HNF363JCH▲	HNF363SCH▲	35	APJ10487 & NPJ10487

### 600V Fusible, 3-Pole, 3-Wire with Viewing Window

30	HF361JCHW▲	HF361SCHW▲	24	APJ3485 & NPJ3485
60	HF362JCHW	HF362SCHW	30	APJ6485 & NPJ6485
100	HF363JCHW▲	HF363SCHW▲	36	APJ10487 & NPJ10487

### 600V Non-Fusible, 3-Pole, 3-Wire with Viewing Window

30	HNF361JCHW▲	HNF361SCHW▲	22	APJ3485 & NPJ3485
60	HNF362JCHW	HNF362SCHW▲	29	APJ6485 & NPJ6485
100	HNF363JCHW▲	HNF363SCHW▲	35	APJ10487 & NPJ10487

## Pyle-National Interlocked Receptacle Switches 3-Poles Fusible and Non-Fusible

Ampere Rating		Voltage Rating	Type 12 Catalog Number <sup>⑤</sup>	Type 12 Stainless Steel Catalog Number <sup>⑥</sup>	Shipping Wt. (lbs.) Std. Pkg.	Accepts Pyle-National QuelArc™ <sup>②③</sup> Plugs Plug Catalog Number
Switch	Receptacle					
30	30	600 (F)	HF361JPN▲	HF361SPN▲	23	JPD-83046
		600 (N-F)	HNF361JPN	HNF361SPN	21	
60	60	240 (F)	HF322JPN▲	—	28	JPD-116046
		600 (F)	HF362JPN▲	HF362SPN▲	28	
		600 (N-F)	HNF362JPN	HNF362SPN	27	

▲ Built to order. Allow 6–8 weeks for delivery.

① Arkite™ is a registered trademark of the Crouse-Hinds Company. Plugs are not sold or supplied by Siemens.

② Indicates plug with maximum diameter cable bushing.

③ QuelArc™ is a registered trademark of the Pyle-National Company.

④ Ampere rating of both switch and receptacle.

⑤ Also rated Type 3R/3S.

⑥ Enclosure is constructed of Type 304 stainless steel.

# Heavy Duty Safety Switches

## Special Application Safety Switches / Type VBII Non-Metallic

### Application

Siemens Non-metallic and 316 grade stainless steel switches provide a superior level of corrosion resistance to assure trouble free performance in the most severe conditions. 316 grade stainless steel provides increased corrosion resistance when compared to 304 grade, especially in atmospheres containing a high level of chlorine commonly encountered in marine and waste management applications. Our non-metallic enclosures are constructed from fiberglass reinforced polyester and are extremely resistant to a wide range

of corrosive atmospheres. They allow a wide range of operating temperatures and their insulating properties virtually eliminate problems caused by internal condensation.

### Description

30-200A, 600V Max, fusible and non-fusible switches are available in both non-metallic and 316 grade stainless steel versions. All are supplied with factory installed ground bars as standard. Viewing windows are also available in the stainless offering.



### Type 4/4X Non-Metallic

Ampere Rating	Catalog Number	Ship Weight Std. pkg. (lbs.)	Horsepower Rating—3-Phase						250 Volts DC	600 Volts DC
			240 Volt AC		480 Volt AC		600 Volt AC			
			Std.	Max.	Std.	Max.	Std.	Max.		
<b>3-Pole, 4-Wire, 240 Volt Fusible, Type 4X<sup>⑤</sup></b>										
30	HF321NX	21	3	7½	—	—	—	—	5	—
60	HF322NX▲	22	7½	15	—	—	—	—	10	—
<b>3-Pole, 4-Wire, 600 Volt AC Fusible, Type 4X<sup>②③⑤</sup></b>										
30	HF361NX	21	3	7½	5	15	7½	20	5	15 <sup>④</sup>
60	HF362NX	22	7½	15	15	30	15	50	10	30 <sup>④</sup>
100	HF363NX▲ <sup>①</sup>	39	15	30	25	60	30	75	20	50 <sup>④</sup>
200	HF364NX▲ <sup>①</sup>	83	25	60	50	125	60	150	40	50
<b>3-Pole, 3-Wire, 600 AC Volt Non-Fusible,<sup>①</sup> Type 4X<sup>②③</sup></b>										
30	HNF361X	20	—	7½	—	20	—	30	5	15 <sup>④</sup>
60	HNF362X	20	—	15	—	50	—	60	10	30 <sup>④</sup>
100	HNF363X▲	38	—	30	—	75	—	100	20	50 <sup>④</sup>
200	HNF364X▲	81	—	60	—	125	—	150	40	50

▲ Built to order. Allow 6–8 weeks for delivery.

① Also used for 240 volt applications.

② Add "L" to end of catalog number for switches less line & load lugs with mounting hardware for crimp type or copper body lugs.

③ 200A switches are also rated 600V DC max.

④ 600V DC voltage and horsepower rating shown requires (2) poles to be connected in series.

⑤ Supplied with factory installed neutral.

# Heavy Duty Safety Switches

## Enclosed Solar Photovoltaic (PV) Switches

Selection

### Application

Solar disconnect switches are designed to be used in the DC portion of photovoltaic power generation circuits. They incorporate powerful magnets within the switch line base which work in combination with a double break switching action to quickly dissipate the very hot arc that is generated when a 600V DC circuit is opened under load. These circuits are defined by article 690 of the NEC which requires the grounded conductor to be at ground potential at all times and therefore cannot be switched.

### Description

30-200A switches are available in both Type 1 and 3R enclosures and in both fusible and non-fusible versions. They are provided with an additional door mounted warning label as required by the NEC and are supplied with a factory installed equipment ground bar. They are built to UL98 requirements but are UL listed in file number E335018 as UL1741 photovoltaic disconnect switches. They are 3 pole switches that are approved to switch 3 separate 600V DC circuits (one per pole). The design incorporates

many of the standard VBII switch features including a rolled out enclosure front flange, a large metal operating handle, oversized line and load lugs and large wire gutters. 1000VDC photovoltaic switches are UL98B listed for solar applications and comply with article 690 of the NEC. The new 400-600Amp switches are also UL98B listed at 600VDC and come in NEMA Type 3R.

### Solar Photovoltaic Enclosed Disconnect Switches

Ampere Rating	Indoor – Type 1		Outdoor – Type 3R		Rated Isc Per NEC Article 690
	Catalog Number	Ship Wt* Std. Pkg.	Catalog Number	Ship Wt* Std. Pkg.	
<b>Negative Ground 3 Pole 3 Wire Fusible 600Volt DC</b>					
30	HF361PV	14	HF361RPV	15	19.2 A
60	HF362PV	20	HF362RPV	21	38.4 A
100	HF363PV▲	25	HF363RPV	26	64.0 A
200	HF364PV▲	49	HF364RPV	50	128.0 A
<b>Negative Ground 3 Pole 3 Wire Non-Fusible 600Volt DC</b>					
30	HNF361PV	12	HNF361RPV	13	24.0 A
60	HNF362PV	19	HNF362RPV	20	48.0 A
100	HNF363PV▲	24	HNF363RPV	25	80.0 A
200	HNF364PV▲	47	HNF364RPV	48	160.0 A
<b>Positive and Negative Ground, 1 Pole, Fusible 1000 Volt DC</b>					
200	HF1104NPV▲	52	HF1104NRPV▲	53	128.0A
<b>Positive and Negative Ground, 1 Pole, Non-Fusible 1000 Volt DC</b>					
200	HNF1104NPV▲	50	HNF1104NRPV▲	51	160.0A
<b>Positive Ground 3 Pole 3 Wire Fusible 600Volt DC</b>					
30	HF361PVPG	14	HF361RPVPG	15	19.2 A
60	HF362PVPG▲	20	HF362RPVPG	21	38.4 A
100	HF363PVPG▲	25	HF363RPVPG▲	26	64.0 A
200	HF364PVPG▲	49	HF364RPVPG▲	50	128.0 A
<b>Positive Ground 3 Pole 3 Wire Non-Fusible 600Volt DC</b>					
30	HNF361PVPG	12	HNF361RPVPG	13	24.0 A
60	HNF362PVPG▲	19	HNF362RPVPG	20	48.0 A
100	HNF363PVPG▲	24	HNF363RPVPG▲	25	80.0 A
200	HNF364PVPG▲	47	HNF364RPVPG▲	48	160.0 A
<b>Positive and Negative Ground, 2 Wire, 600Volt DC, Type 3R</b>					
Amperage Rating	No. Poles	Fuse Type	Catalog Number	Ship Wt* Std. Pkg	Rated Isc Per NEC Article 690
400A	1	Fusible	HF165NRPV▲	165	256A
400A	1	Non-fusible	HNF165NRPV▲	127	256A
600A	1	Fusible	HF166NRPV▲	167	384A
600A	1	Non-fusible	HNF166NRPV▲	129	384A

▲ Built to order. Allow 6-8 weeks for delivery.

\* In pounds (lbs)

Note: All disconnects are rated at 10,000 AIC per UL requirements when used with or protected by Class K, J or R fuses rated at 600VDC.



HF361PV



HNF361RPV



HF362RPV

# General and Heavy Duty Safety Switches

Accessories

Selection



HR612

### Class R Fuse Clip Kits

All General Duty and Heavy Duty Switches are field convertible to accept Class R Fuse Clip Kits. The kits prevent the installation of Class H and K fuses (one kit required per 3-pole switch).

### Class R Fuse Clip Kits

Catalog Number	Description
HR21A	30A, 240V Kit (GD only)
HR21	30A, 240V Kit (HD only)
HR612	30A, 600V Kit
HR22A	60A 240V Kit (GD only)
HR62	60A, 600V Kit
HR63	100A Kit
HR64	200A Kit
HR65A	400A Kit
HR66A	600A Kit

### Class J Fusing

All 30-600A, 600V and 100-600A, 240V fusible Heavy Duty Switches are field convertible to accept Class J fuses by moving the load base to a pre-drilled J fuse position. All 100-600A, 240V fusible General Duty switches can also be field converted to accept Class J fuses.

### Class J Fuse Kits

Catalog Number	Description
HJ66A	600A, 240V/600V Kit

### Internal Shield Kits (for fusible switches)

Kits provide a clear plastic inner door to prevent accidental contact with live parts. Test probe holes are provided and fuses can be replaced without removal of kit.

### Internal Shield Kits<sup>③</sup>

Switch Ampere Rating	Kit Catalog Number	Coverage
30-60A GD Non-fusible	HSK212BA	Line side
30A GD Fusible	HSK21BA	Line side
60A GD Fusible	HSK22BA	Line side
100A GD	HSK23B	Line side
200A GD	HSK24B	Line side
30A HD Fusible <sup>②</sup>	HSK61SSW	Full
60A HD <sup>②</sup>	HSK62SSW	Full
100A HD <sup>②</sup>	HSK63SSW	Full
200A HD <sup>②</sup>	HSK64SSW	Full



HT63

### Class T Fuse Adapter Kits

All 100-600A, General Duty and 100-200Amp and 1200Amp Heavy Duty Switches are field convertible to accept Class T fuses.

### Class T Fuse Adapter Kits<sup>①</sup>

Catalog Number	Description
HT23	100A, 240V Kit
HT63	100A, 600V Kit
HT24	200A, 240V Kit
HT64▲	200A, 600V Kit
HT25A	400A, 240V Kit
HT65A	400A, 600V Kit
HT26A	600A, 240V Kit
HT66A	600A, 600V Kit
TFAK72	800A, 240V Kit
TFAK75	800A, 600V Kit
TFAK82	1200A, 240V Kit



HN612

### Neutral Kits

Standard Neutral Kits can be field installed in General and Heavy Duty Switches.

### Neutral Kits

Switch Ampere Rating	Kit Catalog Number
30 GD	n/a
30 HD	HN612
60 GD	HN22A
60, 100 HD, 100 GD	HN623
200	HN64
400 & 600	HN656A
800 & 1200	HN678

▲ Built to order. Allow 6-8 weeks for delivery.

① One kit per pole required.

② Not designed for use in Non-metallic 4X safety switches. Not designed for use with Auxiliary Contacts.



HN264

### 200% Neutral Kits

UL listed 200% Neutrals are available on 100-600A Heavy Duty Switches. They are typically used with non-linear transformers or where increased neutral ampacity/lug capacity is required.

### 200% Neutral Kits

Switch Ampere Rating	Kit Catalog Number	Wire Range Line & Load Lugs (Cu/Al)
100	HN263	(2) #14-1/0 AWG
200	HN264	(2) #6 AWG-300 Kcmil
400	HN656A	(2) 1/0 AWG-600 Kcmil (2) #6 AWG-300 Kcmil
600	HN678A	(4) 1/0 AWG - 600 Kcmil (2) #6 AWG - 300 Kcmil



HP61

### Fuse Puller Kits

Fuse Puller Kits are field installable in 30-100A Type VBII Heavy Duty Switches (one kit required per 3-pole switch).

### Fuse Puller Kits

Switch Ampere Rating	Fuse Puller Kit Catalog Number
30	HP61
60	HP62▲
100	HP63▲

③ Internal shields meet 2020 NEC 230.62 touch safe requirements for service entrance.

# General and Heavy Duty Safety Switches

## Accessories

## Selection



HA261234



HA265678



HLC612

HG261234

### Auxiliary Contacts

Auxiliary Contacts are available only for Heavy Duty Switches. The auxiliary contacts are available in 1 normally open and 1 normally closed or 2 normally open and 2 normally closed configurations. Siemens offers a PLC Auxiliary Switch (30-600A) that has very low resistance for low voltage and current typical in PLC circuits. All auxiliary contacts make after and break before main switch contacts.

### Auxiliary Contacts<sup>①</sup>

Switch Ampere	Aux. Switch Catalog Number	Kit Ampere Rating			Horsepower Rating	
		125V AC Max.	250V AC Max.	28V DC Max.	125V AC Max.	250V AC Max.
30-600	HA161234	10	10	7	1/2	3/4
800-1200	HA165678	10	10	—	1/2	3/4

### With 1 NO & 1 NC Isolated Contacts

30-600	HA161234	10	10	7	1/2	3/4
800-1200	HA165678	10	10	—	1/2	3/4

### With 2 NO & 2 NC Isolated Contacts

30-600	HA261234	10	10	7	1/2	3/4
800-1200	HA265678	10	10	7	1/2	3/4

### Low Current PLC Type with 1 NO & 1 NC Gold Plated Contacts

30-600	HA361234	10	10	7	1/2	3/4
800-1200	HA365678	10	10	—	1/2	3/4

### Copper Lug Kits

Heavy duty switches are UL approved to accept field installed copper lug kits.

### Copper Lug Kits

Switch Ampere Rating	Copper Lug Catalog Number	Description
30-60	HLC612	(9) Lugs/Kit #14-4 AWG Cu
100	HLC63▲	(9) Lugs/Kit #14-1/0 AWG Cu
200	HLC64▲	(9) Lugs/Kit #6 AWG-300 Kcmil Cu
400-600	HCU656A■	(1) Lugs/Kit #1/0 AWG-600 Kcmil Cu
800-1200	HLC65678	(1) Lugs/Kit #1/0 AWG-600 Kcmil Cu

▲ Built to order. Allow 6-8 weeks for delivery.

■ Purchase field replacement kit along with lugs.

① Series A 400A and 600A switches use HA161234, HA261234 or HA361234 auxiliary contacts. Earlier 400A and 600A switches use HA165678, HA265678 or HA365678 auxiliary contacts.

### Quick Connects

They provide two point control power take-off capability and are normally used on two poles on the line side when it is required to have control power available when the switch is in the OFF position. They provide a mounting provision for standard ¼" quick connect terminal. Installed in the line or load side. 30A VBII switches have lugs UL listed to accept (2) wires per pole as standard so a 30A kit is not required.

### Quick Connects

Catalog Number	Description
HQC62	60A 2 wire quick connect kit
HQC63	100A 2 wire quick connect kit
HQC64	200A 2 wire quick connect kit

### Isolated Ground Kits

Isolated Ground Kits are available on 30-600A Heavy Duty Switches. They are normally used on circuits with a high content of computer or other electronic loading which require a ground which is isolated from the building ground and neutral circuits. The kit includes both isolated and grounded terminals as listed below.

### Isolated Ground Kits

Switch Ampere Rating	Catalog Number	Number of Terminals		Wire Range Per Terminal (Cu/Al)
		Isolated	Grounded	
30-200	HG261234	2	2	#14-4 AWG
400-600	HG2656A	4	4	2/0-14 AWG 2/0-6 AWG

### Equipment Ground Kits

Equipment Ground Lug Kits are available for all General and Heavy Duty Switches. They are field installable in Type 1 and Type 3R Switches and are factory installed as standard in Type 4 / 4X and Type 12 and also in all VBII 4&6-pole Switches.

### Equipment Ground Kits

Switch Ampere Rating	Catalog Number	Number of Terminals	Wire Range Per Terminal (Cu/Al)
30-200 GD	HG61234	2	#14-4 AWG
30-200 HD	HG61234	2	#14-4 AWG
400 & 600	HG656A	4	2/0-6 AWG
800-1200	HG678	8	#6 AWG-250 Kcmil

# General and Heavy Duty Safety Switches

## Hub and Lug Data

## Selection

### Interchangeable Hubs

Conduit hubs are available for Type 3R, 12 and 4 / 4X applications. 30-200A Type 3R Switches are provided with a conduit hub provision and a removable hub plate on their top rainshed.

Conduit Size (inches)	Catalog Number	Used On
-----------------------	----------------	---------

#### Type 3R<sup>①</sup>

Cover	Catalog Number	Used On
3/4	ECHA000	30-60A GD Only
1	ECHA075	
1 1/4	ECHA100	
1 1/4	ECHA125	
Cover	Catalog Number	Used On
3/4	ECHS000	100-200A GD 30-200A HD
1	ECHS075	
1 1/4	ECHS100	
1 1/4	ECHS125	
1 1/2	ECHS150	
2	ECHS200	
2 1/2	ECHS250	
2 1/2	ECHS250	
Cover	Catalog Number	Used On
3	ECHV300	400-1200A
3 1/2	ECHV350	
4	ECHV400	
4	ECHV400	

#### Type 4/4X<sup>②</sup>

Cover	Catalog Number	Used On
3/4	SSH075	30-200A
1	SSH100	
1 1/4	SSH125	
1 1/2	SSH150	
2	SSH200	
2	SSH200	

**Note:** 30 thru 200A. Type 3R Switches have removable hub plates on rainshed. 400A and larger Type 3R Switches have no provisions for mounting hubs. Drill or punch hole in the field to accommodate hub size desired.

### Field Replacement Kits and Neutral Barrier Kits

All Heavy Duty Switches are field convertible for (Crimp) type lugs. When compression lugs are required for 30-100A switches, a neutral barrier kit is required for 1-Phase, 3W or 3-Phase, 4W applications. When compression lugs are required on 400-1200A switches, lug mounting kits are required.

#### Field Replacement Kits and Neutral Barrier Kits

Switch Ampere Rating	Catalog Number	Kit Description
30	HCL612	Neutral Barrier Kit
60 & 100	HCL623	Neutral Barrier Kit
400	HCM65A	240V/600V Fusible Kit
400	HNCM65A	240/600V Non-Fusible Kit
600	HCM66A	240V/600V Fusible Kit
600	HNCM66A	240V/600V Non-Fusible Kit
800 & 1200 <sup>③</sup>	HCL65678■	1 Pole, Compression Lug Mounting Kit

### Lugs

30 & 60A HD Switches are suitable for use with 60° or 75°C wire. 100-1200A are suitable for use with 75°C rated wire.

### Multiple Padlock Accessory

A tamper-proof device to provide for multiple padlocking to meet OSHA or plant requirements. Accepts up to 6 1/4" padlocks. Catalog number **SL0420**. Standard Carton-12.



### Wire Ranges (Line, Load and Standard Neutral)

Switch Ampere Rating	Wire Range with Wire Bending Space Per NEC Requirements	Lug Wire Range
30GD	#14-8 AWG (Cu/Al)	#14-2 AWG (Cu/Al) <sup>①</sup>
60GD	#14-6 AWG (Cu)	#14-2 AWG (Cu) <sup>①</sup>
30HD	#14-6 AWG (Cu/Al)	#14-2 AWG (Cu/Al)
60HD <sup>②</sup>	#14-3 AWG (Cu/Al)	#14-2 AWG (Cu/Al)
100 <sup>①</sup>	#14-1/0 AWG (Cu/Al)	#14-1/0 AWG (Cu/Al)
200 <sup>②</sup>	#6 AWG-250 Kcmil (Cu/Al)	#6 AWG-300 Kcmil (Cu/Al)
400 <sup>②</sup>	(1) 1/0 AWG-600 Kcmil (Cu/Al) (2) 1/0 AWG-500 Kcmil (Cu/Al)	(2) 1/0 AWG-600 Kcmil (Cu/Al)
600 <sup>②</sup>	(1) 1/0 AWG-600 Kcmil (Cu/Al) (2) 1/0 AWG-500 Kcmil (Cu/Al)	(2) 1/0 AWG-600 Kcmil (Cu/Al)
800	(3) 1/0 AWG-750 Kcmil (Cu/Al) Line Load (4) 1/0 AWG-750 Kcmil (Cu/Al) neutral	(3) 1/0 AWG-750 Kcmil (Cu/Al) Line Load (4) 1/0 AWG-750 Kcmil (Cu/Al) neutral
1200	(4) 3/0 AWG-750 Kcmil (Cu/Al) Line Load (4) 1/0 AWG-750 Kcmil (Cu/Al) neutral	(4) 1/0 AWG-750 Kcmil (Cu/Al) Line Load (4) 1/0 AWG-750 Kcmil (Cu/Al) neutral

■ Built to order. Allow 3-4 weeks for delivery.

- ① Hubs suitable for 3R Switches.
- ② Also suitable for Type 12 applications.
- ③ Neutral Barrier kits are required on 30-100A switches only and only with 1-Phase / 3W or 3-Phase / 4W loads. Compression Lugs mounting kits are required on 400-1200A switches only.
- ④ Provides mounting for a single line or load lug.
- ⑤ Provides mounting for (2) compression lugs per phase on line or load.
- ⑥ Neutral lugs (only) are UL approved to accept #14-4 CU/Al cable.
- ⑦ Max. wire size for height reduced switches is 500 kcmil (Cu/Al).
- ⑧ Compact HD NF switches are also UL approved for #2 Cu/Al conductors.
- ⑨ All 200A Heavy Duty Switches have a wire range & wire bending space for (1) #6-300 Kcmil (Cu/Al).
- ⑩ Also for 30A oversized heavy duty switches.
- ⑪ Also for 60A oversized heavy duty switches.

# General and Heavy Duty Safety Switches

Dimensions

## Safety Switch Dimensions (Inches)\* & Shipping Weights

Catalog Number	Height			Width		Depth		Knockout Diagram <sup>Ⓞ</sup>	Shipping Weight (lbs.)
	Box A	With Door B	With Rain Shed C	Box D	With Handle E	Box F	With Handle G		
GF221NA	8.4	8.56	—	5.08	5.44	2.93	3.96	S4	30(10)
GF221NRA	8.4	8.56	8.56	5.08	5.44	2.93	3.96	S5	30(10)
GF222NA	9.91	10.07	—	6.06	6.42	3.21	4.24	S21	20(5)
GF222NRA	9.91	10.07	10.07	6.06	6.42	3.21	4.24	S22	20(5)
GF223N	21.95	23.15	—	9.64	11.7	5.05	8.63	S10	23
GF223NR	21.95	—	23.46	9.64	11.67	5.05	8.7	S11	24
GF224N	29.9	31.07	—	14.62	16.68	6.36	10.92	S12	47
GF224NR	29.9	—	31.42	14.61	16.68	6.36	10.92	S13	48
GF225NA	45.32	45.81	—	22.4	23.404	6.94	9.93	S18	91.1
GF225NRA	45.32	45.81	—	22.4	23.404	6.94	9.93	S19	91.1
GF226NA	45.32	45.81	—	22.4	23.404	6.94	9.93	S18	95.6
GF226NRA	45.32	45.81	—	22.4	23.404	6.94	9.93	S19	95.6
GF321NA	8.4	8.56	—	5.08	5.44	2.93	3.96	S4	30(10)
GF321NRA	8.4	8.56	8.56	5.08	5.44	2.93	3.96	S5	30(10)
GF322NA	9.91	10.07	—	6.06	6.42	3.21	4.24	S21	20(5)
GF322NRA	9.91	10.07	10.07	6.06	6.42	3.21	4.24	S22	20(5)
GF323N	21.95	23.15	—	9.64	11.7	5.05	8.63	S10	25
GF323NR	21.95	—	23.46	9.64	11.67	5.05	8.7	S11	25
GF324N	29.9	31.07	—	14.62	16.68	6.36	10.92	S12	49
GF324NR	29.9	—	31.42	14.61	16.68	6.36	10.92	S13	50
GF325NA	45.32	45.81	—	22.4	23.404	6.94	9.93	S18	94.6
GF325NRA	45.32	45.81	—	22.4	23.404	6.94	9.93	S19	94.6
GF326NRA	45.32	45.81	—	22.4	23.404	6.94	9.93	S19	99.6
GF326NA	45.32	45.81	—	22.4	23.404	6.94	9.93	S18	99.6
GF326NRA	45.32	45.81	—	22.4	23.404	6.94	9.93	S19	99.6
GNF221A	6.18	6.35	—	4.2	4.56	2.88	3.93	S4	20(10)
GNF221RA	6.18	6.35	6.35	4.2	4.56	2.88	3.93	S5	20(10)
GNF321LA, GN221LA	8.4	8.56	—	5.08	5.43	2.93	3.95	S4	30(10)
GNF321RLA, GN221RLA	8.4	8.56	8.56	5.08	5.43	2.93	3.95	S5	30(10)
GNF222A	8.4	8.56	—	5.08	5.43	2.93	3.95	S4	30(10)
LNF222RA, LNF221RLA	8.4	8.56	8.56	5.08	5.43	2.93	3.95	S20	30(10)
GNF222RA	8.4	8.56	8.56	5.08	5.43	2.93	3.95	S5	30(10)
GNF321A	6.18	6.35	—	4.2	4.56	2.88	3.93	S4	20(10)
GNF321RA	6.18	6.35	6.35	4.2	4.56	2.88	3.93	S5	20(10)
GNF322A	8.4	8.56	—	5.08	5.43	2.93	3.95	S4	30(10)
GNF322RA	8.4	8.56	8.56	5.08	5.43	2.93	3.95	S5	30(10)
GNF323	21.95	23.15	—	9.64	11.7	5.05	8.63	S10	23
GNF323R	21.95	—	23.46	9.64	11.67	5.05	8.7	S11	24
GNF324	29.9	31.07	—	14.62	16.68	6.36	10.92	S12	46
GNF324R	29.9	—	31.42	14.61	16.68	6.36	10.92	S13	47
GNF325A	33.47	33.96	—	22.4	23.404	6.94	9.93	S18	75
GNF326A	33.47	33.96	—	22.4	23.404	6.94	9.93	S18	77
HF221J also HF261J	14.27	17.33	—	6.65	9.02	5.32	10.46	—	13
HF221N also HF261	14.26	14.60	—	6.64	7.75	4.71	8.89	S6	13
HF221NR also HF261R	14.34	—	14.91	6.64	7.88	5.00	9.18	S8	14
HF221S also HF261S	14.27	17.33	—	6.65	9.02	5.32	10.46	—	13
HF222J also HF262J	16.22	19.31	—	9.17	11.47	5.33	10.46	—	19
HF222N also HF262	16.26	16.62	—	9.16	10.37	4.71	8.67	S16	18
HF222NR also HF262R	16.26	—	16.93	9.16	10.41	5.05	9.21	S17	19
HF222S also HF262S	16.22	19.31	—	9.17	11.47	5.33	10.46	—	19
HF223J also HF263J	21.96	23.16	—	9.65	12.02	5.34	10.46	—	24
HF223N also HF263	21.95	23.15	—	9.64	12.01	5.05	10.17	S10	23
HF223NR also HF263R	21.95	—	23.46	9.64	11.97	5.05	10.17	S11	24
HF223S also HF263S	21.96	23.16	—	9.65	12.02	5.34	10.46	—	24
HF224J	29.96	31.07	—	14.62	16.95	6.63	12.58	—	48
HF224N	29.9	31.07	—	14.62	16.98	6.36	12.33	S12	47
HF224NR	29.9	—	31.42	14.61	16.99	6.36	12.33	S13	48
HF224S	29.96	31.07	—	14.62	16.95	6.63	12.58	—	48
HF225NRA	45.32	45.81	—	22.4	23.404	6.94	9.93	S19	91.1
HF225NA	45.32	45.81	—	22.4	23.404	6.94	9.93	S18	91.1
HF226NA	45.32	45.81	—	22.4	23.404	6.94	9.93	S18	95.6
HF226NRA	45.32	45.81	—	22.4	23.404	6.94	9.93	S19	95.6
HF227N	66.67	67.16	—	38.4	39.96	9.24	14.68	—	360
HF227NR	66.67	—	67.74	38.4	39.96	9.24	14.68	—	362
HF228N	66.67	67.16	—	38.4	39.96	9.24	14.68	—	362
HF228NR	66.67	—	67.74	38.4	39.96	9.24	14.68	—	364

\*For inches / millimeters conversion, multiply inches by 25.4.

Ⓞ Knocks not provided on Type 4 / 4X and 12 or in 800 &amp; 1200A switches.

# General and Heavy Duty Safety Switches

Dimensions

## Safety Switch Dimensions (Inches)\* & Shipping Weights

Catalog Number	Height			Width		Depth		Knockout Diagram <sup>①</sup>	Shipping Weight (lbs.)
	Box A	With Door B	With Rain Shed C	Box D	With Handle E	Box F	With Handle G		
HF261	14.26	14.60	—	6.64	7.75	4.71	8.89	S6	13
HF261R	14.34	—	14.91	6.64	7.88	5.00	9.18	S8	14
HF262	16.26	16.62	—	9.16	10.37	4.71	8.67	S16	18
HF262R	16.26	—	16.93	9.16	10.41	5.05	9.21	S17	19
HF321J	14.27	17.33	—	6.65	9.02	5.32	10.46	—	14
HF321N	14.26	14.60	—	6.64	7.75	4.71	8.89	S6	13
HF321NR	14.34	—	14.91	6.64	7.88	5.00	9.18	S8	14
HF321S, SS	14.27	17.33	—	6.65	9.02	5.32	10.46	—	14
HF322J	16.27	19.31	—	9.17	11.47	5.33	10.46	—	20
HF322N	16.26	16.62	—	9.16	10.37	4.71	8.67	S16	18
HF322NR	16.26	—	16.93	9.16	10.41	5.05	9.21	S17	19
HF322S, SS	16.27	19.31	—	9.17	11.47	5.33	10.46	—	20
HF323J	21.96	23.16	—	9.65	12.02	5.34	10.46	—	25
HF323N	21.95	23.15	—	9.64	12.01	5.05	10.17	S10	25
HF323NR	21.95	—	23.46	9.64	11.97	5.05	10.17	S11	26
HF323S, SS	21.96	23.16	—	9.65	12.02	5.34	10.46	—	25
HF324J	29.96	31.07	—	14.62	16.95	6.63	12.58	—	49
HF324N	29.9	31.07	—	14.62	16.98	6.36	12.33	S12	49
HF324NR	29.9	—	31.42	14.61	16.99	6.36	12.33	S13	50
HF324S, SS	21.96	31.07	—	14.62	16.95	6.63	12.58	—	49
HF325JA	45.32	45.81	—	22.4	23.404	6.97	10.05	—	93
HF325NA	45.32	45.81	—	22.4	23.404	6.94	9.93	S18	94.6
HF325NRA	45.32	45.81	—	22.4	23.404	6.94	9.93	S19	94.6
HF325SA	45.32	45.81	—	22.4	23.404	7.34	10.347	—	93
HF325SSA	45.32	45.81	—	22.4	23.404	7.34	10.347	—	93
HF326JA	45.32	45.81	—	22.4	23.404	6.97	10.05	—	98
HF326NA	45.32	45.81	—	22.4	23.404	6.94	9.93	S18	99.6
HF326NRA	45.32	45.81	—	22.4	23.404	6.94	9.93	S19	99.6
HF326SA	45.32	45.81	—	22.4	23.404	7.34	10.347	—	98
HF326SSA	45.32	45.81	—	22.4	23.404	7.34	10.347	—	98
HF327J	66.67	67.16	—	38.4	39.96	9.24	14.68	—	367
HF327N	66.67	67.16	—	38.4	39.96	9.24	14.68	—	380
HF327NR	66.67	—	67.74	38.4	40.25	9.24	14.68	—	383
HF327S	66.67	67.16	—	38.4	39.96	9.24	14.68	—	367
HF328N	66.67	67.16	—	38.4	39.96	9.24	14.68	—	382
HF328NR	66.67	—	67.74	38.4	40.25	9.24	14.68	—	385
HF361, PV, PVPG	14.26	14.60	—	6.64	7.75	4.71	8.89	S6	13
HF361J, JW	14.27	17.33	—	6.65	9.02	5.32	10.46	—	14
HF361L	16.26	17.46	—	9.15	11.53	5.05	10.17	S16	19
HF361N	14.26	14.60	—	6.64	7.75	4.71	8.89	S6	13
HF361NR	14.34	—	14.91	6.64	7.88	5.00	9.18	S8	14
HF361R, RPV, RPVPG	14.34	—	14.91	6.64	7.88	5.00	9.18	S8	14
HF361RL, RW	16.26	—	16.93	9.16	10.41	5.05	9.21	S17	19
HF361S, SS, SSW, SW	14.27	17.33	—	6.65	9.02	5.32	10.46	—	15
HF362, PV, PVPG	16.26	16.62	—	9.16	10.37	4.71	8.67	S16	18
HF362J, JW	16.27	19.31	—	9.17	11.47	5.33	10.46	—	20
HF362N	16.26	16.62	—	9.16	10.37	4.71	8.67	S16	18
HF362NR	16.26	—	16.93	9.16	10.41	5.05	9.21	S17	19
HF362R, RPV, RPVPG, RW	16.26	—	16.93	9.16	10.41	5.05	9.21	S17	19
HF362RL	21.95	—	23.46	9.64	11.97	5.05	10.17	S11	25
HF362S, SS, SSW, SW	16.27	19.31	—	9.17	11.47	5.33	10.46	—	20
HF363, PV, PVPG	21.95	23.15	—	9.64	12.01	5.05	10.17	S10	24
HF363J, JW	21.96	23.16	—	9.65	12.02	5.34	10.46	—	25
HF363N	21.95	23.15	—	9.64	12.01	5.05	10.17	S10	25
HF363NR	21.95	—	23.46	9.64	11.97	5.05	10.17	S11	26
HF363R, RPV, RPVPG	21.95	—	23.46	9.64	11.97	5.05	10.17	S11	25
HF363S, SS, SSW, SW	21.96	23.16	—	9.65	12.02	5.34	10.46	—	25
HF364, PV, PVPG	29.9	31.07	—	14.62	16.98	6.36	12.33	S12	48
HF364J, JW	29.96	31.07	—	14.62	16.95	6.63	12.58	—	49
HF364N	29.9	31.07	—	14.62	16.98	6.36	12.33	S12	49
HF364NR	29.9	—	31.42	14.61	16.99	6.36	12.33	S13	48
HF364R, RPV, RPVPG	29.9	—	31.42	14.61	16.99	6.36	12.33	S13	49
HF364S, SS, SSW, SW	29.96	31.07	—	14.62	16.95	6.63	12.58	—	49
HF365A	45.32	45.81	—	22.4	23.404	6.94	9.93	S18	93
HF365JA, JWA	45.32	45.81	—	22.4	23.404	6.97	10.05	—	93
HF365NA	45.32	45.81	—	22.4	23.404	6.94	9.93	S18	94.6
HF365NRA	45.32	45.81	—	22.4	23.404	6.94	9.93	S19	94.6

\*For inches / millimeters conversion, multiply inches by 25.4.

① Knocks not provided on Type 4 / 4X and 12 or in 800 &amp; 1200A switches.

# General and Heavy Duty Safety Switches

Dimensions

## Safety Switch Dimensions (Inches)\* & Shipping Weights

Catalog Number	Height			Width		Depth		Knockout Diagram <sup>①</sup>	Shipping Weight (lbs.)
	Box A	With Door B	With Rain Shed C	Box D	With Handle E	Box F	With Handle G		
HF365RA	45.32	45.81	—	22.4	23.404	6.94	9.93	S19	93
HF365SA, SS, SWA, SSWA	45.32	45.81	—	22.4	23.404	7.34	10.347	—	93
HF366A	45.32	45.81	—	22.4	23.404	6.94	9.93	S18	98
HF366JA, JWA	45.32	45.81	—	22.4	23.404	6.97	10.05	—	98
HF366NA	45.32	45.81	—	22.4	23.404	6.94	9.93	S18	99.6
HF366NRA	45.32	45.81	—	22.4	23.404	6.94	9.93	S19	99.6
HF366RA	45.32	45.81	—	22.4	23.404	6.94	9.93	S19	98
HF366SA, SSA	45.32	45.81	—	22.4	23.404	7.34	10.347	—	98
HF367	66.67	67.16	—	38.4	39.96	9.24	14.68	—	380
HF367J, JW	66.67	67.16	—	38.4	39.96	9.24	14.68	—	380
HF367N	66.67	67.16	—	38.4	39.96	9.24	14.68	—	382
HF367NR	66.67	—	67.74	38.4	40.25	9.24	14.68	—	386
HF367R, RW	66.67	—	67.74	38.4	40.25	9.24	14.68	—	382
HF367S, SW	66.67	67.16	—	38.4	39.96	9.24	14.68	—	380
HF368, J, S, JW, SW	66.67	67.16	—	38.4	39.96	9.24	14.68	—	383
HF368N	66.67	67.16	—	38.4	39.96	9.24	14.68	—	385
HF368NR	66.67	—	67.74	38.4	40.25	9.24	14.68	—	388
HF368R, RW	66.67	—	67.74	38.4	40.25	9.24	14.68	—	385
HFC221N	14.26	14.6	—	6.64	7.75	4.71	8.89	S6	13
HFC221NR	14.34	—	14.91	6.64	7.88	5	9.18	S8	14
HFC222N	16.26	16.62	—	9.16	10.37	4.71	8.67	S16	18
HFC222NR	16.26	—	16.93	9.16	10.41	5.05	9.21	S17	19
HFC261	14.26	14.6	—	6.64	7.75	4.71	8.89	S6	13
HFC261R	14.34	—	14.91	6.64	7.88	5	9.18	S8	14
HFC262	16.26	16.62	—	9.16	10.37	4.71	8.67	S16	18
HFC262R	16.26	—	16.93	9.16	10.41	5.05	9.21	S17	19
HFC321N	14.26	14.6	—	6.64	7.75	4.71	8.89	S6	13
HFC321NR	14.34	—	14.91	6.64	7.88	5	9.18	S8	14
HFC322N	16.26	16.62	—	9.16	10.37	4.71	8.67	S16	18
HFC322NR	16.26	—	16.93	9.16	10.41	5.05	9.21	S17	19
HFC361	14.26	14.6	—	6.64	7.75	4.71	8.89	S6	13
HFC361N	14.26	14.6	—	6.64	7.75	4.71	8.89	S6	13
HFC361NR	14.34	—	14.91	6.64	7.88	5	9.18	S8	14
HFC361R	14.34	—	14.91	6.64	7.88	5	9.18	S8	14
HFC362	16.26	16.62	—	9.16	10.37	4.71	8.67	S16	18
HFC362N	16.26	16.62	—	9.16	10.37	4.71	8.67	S16	18
HFC362NR	16.26	—	16.93	9.16	10.41	5.05	9.21	S17	19
HFC362R	16.26	—	16.93	9.16	10.41	5.05	9.21	S17	19
HNF365JA, JWA	45.32	45.81	—	22.4	23.404	6.97	10.05	—	75
HNF365RA	33.47	33.96	—	22.4	23.404	6.94	9.93	S19	75
HNF365SA, SSA, SWA, SSWA	33.47	33.96	—	22.4	23.404	7.34	10.347	—	75
HNF366SA, SSA	33.47	33.96	—	22.4	23.404	7.34	10.347	—	77
HNF366JA, JWA	45.32	45.81	—	22.4	23.404	6.97	10.05	—	77
HNF366RA	33.47	33.96	—	22.4	23.404	6.94	9.93	S19	77
HNF361, PV, PVPG also HNF261 & HNF362H, HNFC261, HNFC361	11.11	11.45	—	6.64	7.72	4.7	9.15	S7	11
HNF361J, JW also HNF261J & HNF362JH	11.12	14.14	—	6.65	9.02	5.56	10.46	—	13
HNF361R, RPV, RPVPG also HNF261R & HNF362RH, HNFC261R, HNFC361R	11.09	—	11.76	6.64	7.88	5	8.91	S9	12
HNF361RL, HNF362R, RPV, RPVPG also HNF262R, HNFC262R, HNFC362R	16.26	—	16.93	9.16	10.41	5.05	9.14	S17	18
HNF361S, SS, SSW, SW also HNF261S & HNF362SH	11.12	14.14	—	6.65	9.02	5.56	10.46	—	13
HNF362, PV, PVPG also HNF262, HNFC262, HNFC362	16.26	16.62	—	9.16	10.26	4.71	9.04	S16	17
HNF362J, JW also HNF262J	16.27	17.46	—	9.17	11.47	5.33	10.46	—	19
HNF362RL, HNFC262R, HNFC362R	21.95	—	23.46	9.64	11.97	5.05	10.17	S11	24
HNF362S, SS, SSW, SW also HNF262S	16.27	17.46	—	9.17	11.47	5.33	10.46	—	19
HNF363, PV, PVPG also HNF263	21.95	23.16	—	9.64	12.01	5.05	10.17	S10	23
HNF363J, JW also HNF263J	21.96	23.16	—	9.65	12.02	5.34	10.46	—	24
HNF363R, RPV, RPVPG also HNF263R	21.95	—	23.46	9.64	11.97	5.05	10.17	S11	24
HNF363S, SS, SSW, SW also HNF263S	21.96	23.16	—	9.65	12.02	5.34	10.46	—	24
HNF364, PV, PVPG	29.9	31.07	—	14.62	16.98	6.36	12.33	S12	46
HNF364J, JW	29.96	31.07	—	14.62	16.95	6.63	12.58	—	47
HNF364R, RPV, RPVPG	29.9	—	31.42	14.61	16.99	6.36	12.33	S13	47
HNF364S, SS, SSW, SW	29.96	31.07	—	14.62	16.95	6.63	12.58	—	47
HNF365JA, JWA	45.32	45.81	—	22.4	23.404	6.97	10.05	—	75

\*For inches / millimeters conversion, multiply inches by 25.4.

① Knocks not provided on Type 4 / 4X and 12 or in 800 &amp; 1200A switches.

# General and Heavy Duty Safety Switches

Dimensions

## Safety Switch Dimensions (Inches)\* & Shipping Weights

Catalog Number	Height			Width		Depth		Knockout Diagram <sup>①</sup>	Shipping Weight (lbs.)
	Box A	With Door B	With Rain Shed C	Box D	With Handle E	Box F	With Handle G		
HN365RA	33.47	33.96	—	22.4	23.404	6.94	9.93	S19	75
HN365SA, SSA, SWA, SSWA	33.47	33.96	—	22.4	23.404	7.34	10.347	—	75
HN366JA, JWA	45.32	45.81	—	22.4	23.404	6.97	10.05	—	77
HN366RA	33.47	33.96	—	22.4	23.404	6.94	9.93	S19	77
HN366SA	33.47	33.96	—	22.4	23.404	7.34	10.347	—	77
HN367, J, JWA	54.67	55.16	—	38.4	39.96	9.24	14.68	—	302
HN367R, RW	54.67	—	55.7	38.4	40.25	9.24	14.68	—	304
HN367S, SW	54.67	55.16	—	38.4	39.96	9.24	14.68	—	302
HN368, J, S, SW, JW	54.67	55.16	—	38.4	39.96	9.24	14.68	—	305
HN368R, RW	54.67	55.16	—	38.4	40.25	9.24	14.68	—	307
LF111N	7.97	8.13	—	5.5	5.94	3	5.38	S2	35 (10)
LF111NR	8.07	—	8.16	5.16	5.94	3.13	5.38	S3	35 (10)
LF211N	7.97	8.13	—	5.5	5.94	3	5.38	S1	35 (10)
LF211NR	8.07	—	8.16	5.16	5.94	3.13	5.38	S3	35 (10)
US2:HF361PV	14.26	14.6	—	6.64	7.75	4.71	8.89	S6	13
US2:HF361PVPG	14.26	14.6	—	6.64	7.75	4.71	8.89	S6	13
US2:HF361RPV	14.34	—	14.91	6.64	7.88	5	9.18	S8	14
US2:HF361RPVPG	14.34	—	14.91	6.64	7.88	5	9.18	S8	14
US2:HF362PV	16.26	16.62	—	9.16	10.37	4.71	8.67	S16	18
US2:HF362PVPG	16.26	16.62	—	9.16	10.37	4.71	8.67	S16	18
US2:HF362RPV	16.26	—	16.93	9.16	10.41	5.05	9.21	S17	19
US2:HF362RPVPG	16.26	—	16.93	9.16	10.41	5.05	9.21	S17	19
US2:HN361PV	11.11	11.45	—	6.64	7.72	4.7	9.15	S7	11
US2:HN361PVPG	11.11	11.45	—	6.64	7.72	4.7	9.15	S7	11
US2:HN361RPV	11.09	—	11.76	6.64	7.88	5	8.91	S9	12
US2:HN361RPVPG	11.09	—	11.76	6.64	7.88	5	8.91	S9	12
US2:HN362PV	16.26	16.62	—	9.16	10.26	4.71	9.04	S16	17
US2:HN362PVPG	16.26	16.62	—	9.16	10.26	4.71	9.04	S16	17
US2:HN362RPV	16.26	—	16.93	9.16	10.41	5.05	9.14	S17	18
US2:HN362RPVPG	16.26	—	16.93	9.16	10.41	5.05	9.14	S17	18

4 SAFETY SWITCHES

**Type 1 or 3R  
30-60A GD**

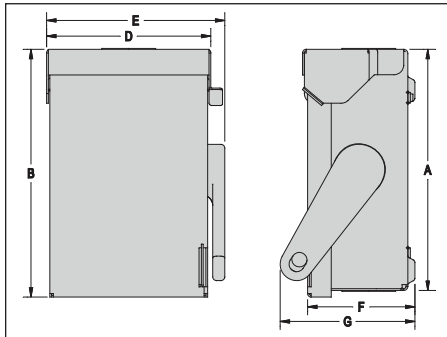

**Type 1 or 3R  
100-200A GD, 30-200A HD Type VBII**

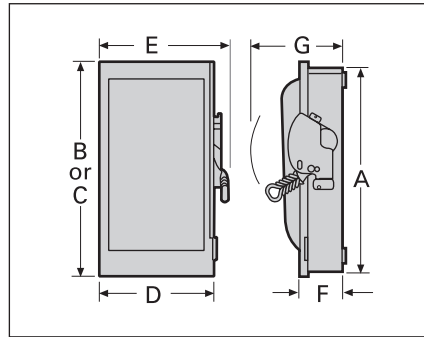

**Type 4/4X or 12  
30-200A HD Type VBII**

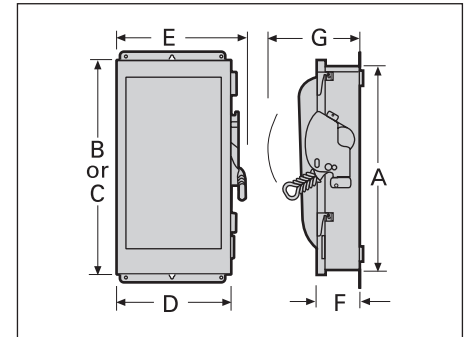

**Type 1 or 3R  
400-1200A Type VBII (GD & HD)**

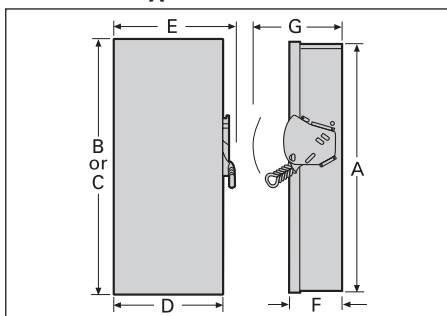

**Type 4/4X or 12  
400-1200A HD Type VBII**

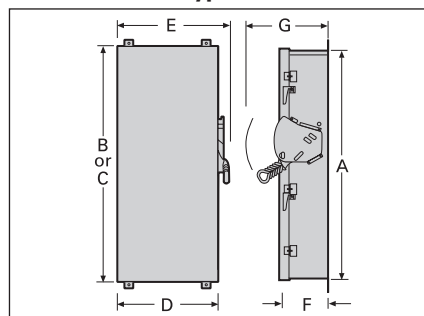

\*For inches / millimeters conversion, multiply inches by 25.4.

① Knocks not provided on Type 4 / 4X and 12 or in 800 & 1200A switches.

# General and Heavy Duty Safety Switches

## Knockout Diagrams

### Type 1 & 3R Enclosures

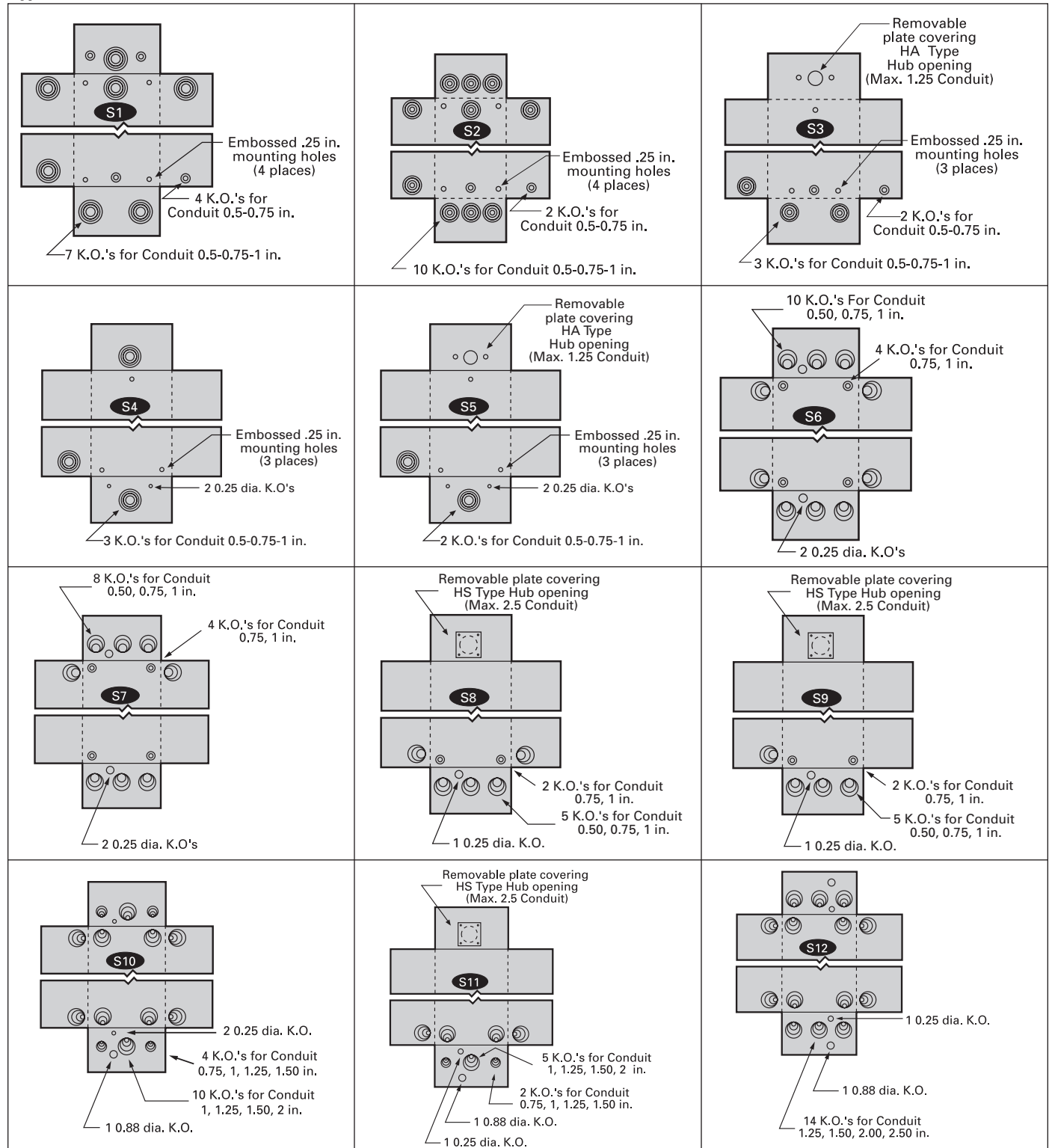

\*For inches / millimeters conversion, multiply inches by 25.4.

# General and Heavy Duty Safety Switches

## Type 1 & 3R Enclosures

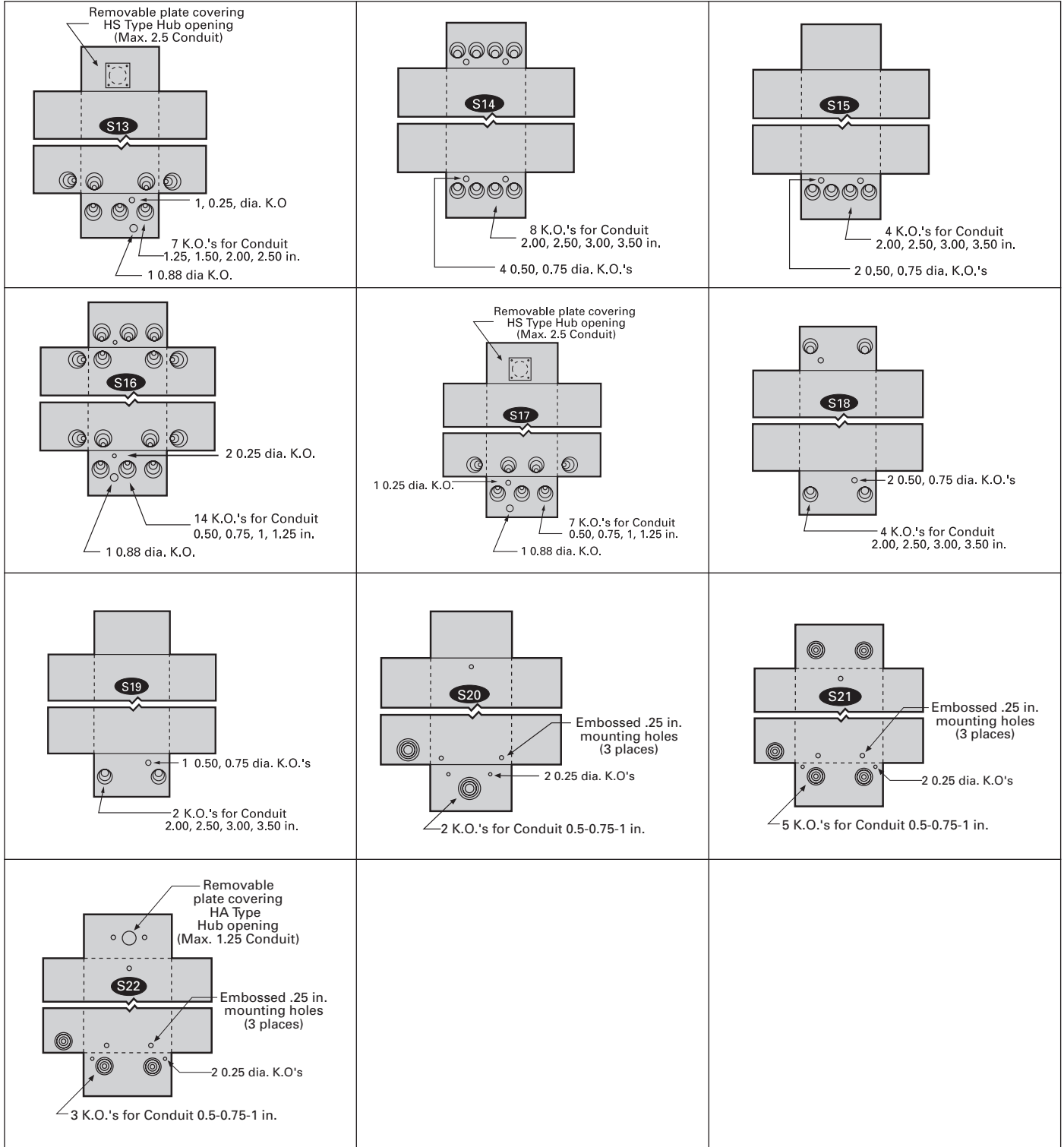

\*For inches / millimeters conversion, multiply inches by 25.4.

# Special Application Safety Switches Dimension Drawings

Non-Metallic

Dimensions

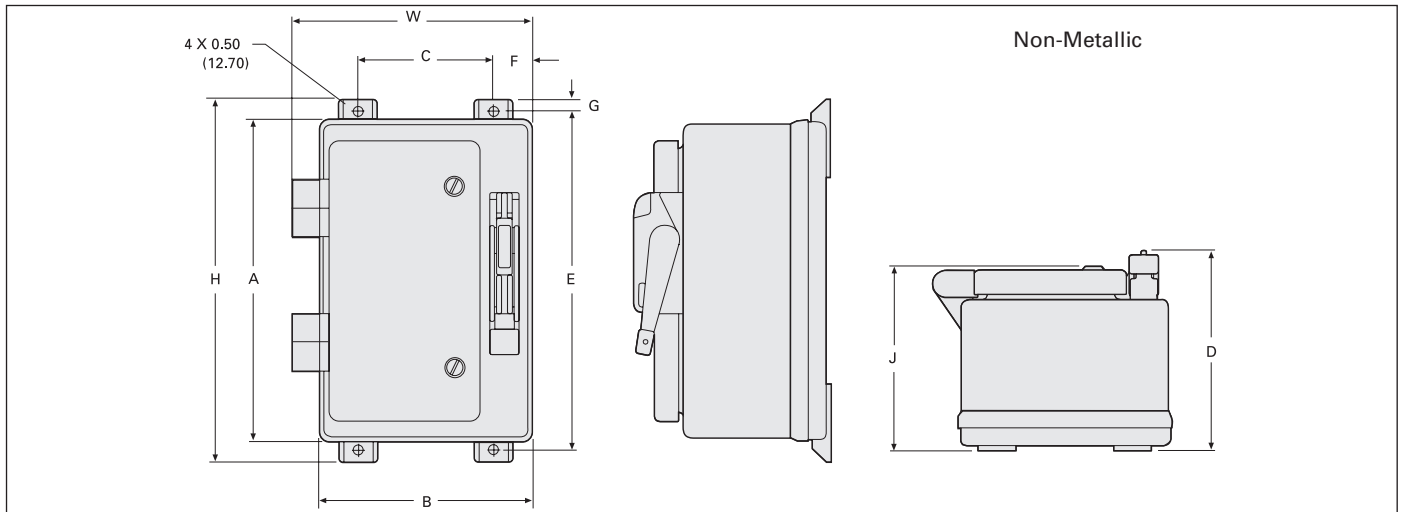

Catalog Number	Dimensions (Inches) Non-Metallic									
	H	W	D	A	B	C	E	F	G	J
HF321NX	18.75	12.11	10.25	16.59	10.97	7.00	17.50	1.98	.46	9.20
HF322NX	18.75	12.11	10.25	16.59	10.97	7.00	17.50	1.98	.46	9.20
HF361NX <sup>Ⓞ</sup>	18.75	12.11	10.25	16.59	10.97	7.00	17.50	1.98	.46	9.20
HF362NX <sup>Ⓞ</sup>	18.75	12.11	10.25	16.59	10.97	7.00	17.50	1.98	.46	9.20
HF363NX <sup>Ⓞ</sup>	26.95	14.87	13.25	24.84	13.72	6.25	25.75	3.75	.46	12.15
HF364NX <sup>Ⓞ</sup>	33.41	27.47	13.19	31.31	26.31	18.50	32.25	3.91	.47	12.10
HNF361X <sup>Ⓞ</sup>	18.75	12.11	10.25	16.59	10.97	7.00	17.50	1.98	.46	9.20
HNF362X <sup>Ⓞ</sup>	18.75	12.11	10.25	16.59	10.97	7.00	17.50	1.98	.46	9.20
HNF363X <sup>Ⓞ</sup>	26.95	14.87	13.25	24.84	13.72	6.25	25.75	3.75	.46	12.15
HNF364X <sup>Ⓞ</sup>	33.41	27.47	13.19	31.31	26.31	18.50	32.25	3.91	.47	12.10

4 SAFETY SWITCHES

## VBI Interlocked Receptacle Switches

Ampere Rating	Dimensions (Inches)						
	A	B	C	D	E	F	G
<b>Cr-H Type Fusible (240 &amp; 600V)</b>							
30	14.27	7.42	9.02	6.22	1.52	6.1	6.0
60	16.27	9.17	11.47	6.34	1.52	6.4	7.4
100	21.96	9.65	12.02	6.80	1.52	6.5	7.6
<b>Cr-H Type Non-Fusible (600V max.)</b>							
30	14.27	7.42	9.02	6.22	1.52	6.1	6.0
60	16.27	9.17	11.47	6.34	1.52	6.4	7.4
100	21.96	9.65	12.02	6.80	1.52	6.5	7.6
<b>Pyle-National Type Fusible (240 &amp; 600V)</b>							
30	14.27	7.42	9.02	6.22	1.52	3.5	3.0
60	16.27	9.17	11.47	6.34	1.52	5.0	4.5
<b>Pyle-National Type Non-Fusible (600V max.)</b>							
30	14.27	7.42	9.02 <sup>Ⓞ</sup>	6.22	1.52	3.5	3.0
60	16.27	9.17	11.47 <sup>Ⓞ</sup>	6.34	1.52	5.0	4.5

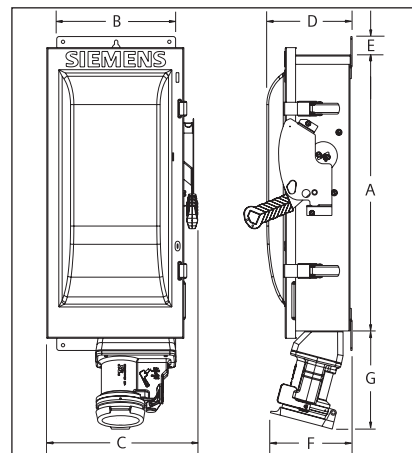

\*For inches / millimeters conversion, multiply inches by 25.4.

<sup>Ⓞ</sup> Dimensions also apply to "L" suffix switches (less lugs).

# Special Application Safety Switches Dimension Drawings

4-Pole & 6-Pole

Dimensions

## 4 & 6-Pole Safety Switch Dimensions – Inches (mm)

Catalog Number	Enclosure			Mounting		
	A	B	C	D	E	F

**Figure 1, 4-Pole Fusible and Non-fusible, Type 1**

HNF461	24.50 (622)	9.53 (242)	6.09 (155)	19.00 (483)	6.75 (171)	0.268 (7)
HF461	29.12 (740)	9.53 (242)	6.09 (155)	23.50 (597)	6.75 (171)	0.268 (7)
HNF462	24.88 (632)	11.50 (292)	6.09 (155)	19.00 (483)	9.38 (238)	0.268 (7)
HF462	33.53 (852)	11.50 (292)	6.09 (155)	27.50 (699)	9.38 (238)	0.268 (7)
HNF463	27.62 (702)	12.18 (309)	6.09 (155)	19.36 (492)	8.00 (203)	0.268 (7)
HF463	36.44 (926)	12.18 (309)	6.09 (155)	28.11 (714)	8.00 (203)	0.268 (7)
HNF464	36.00 (914)	19.12 (486)	6.42 (163)	30.88 (784)	15.00 (381)	0.44 (11)
HF464	49.48 (1257)	19.12 (486)	6.42 (163)	45.50 (1130)	15.00 (381)	0.44 (11)

**Figure 2, 4 & 6-Pole Fusible Type 12/3R and 4X**

HF461J, HF661J, HF661S	29.50 (622)	9.53 (242)	6.48 (165)	31.65 (804)	5.47 (139)	0.27 (7)
HF462J, HF662J, HF662S	33.53 (852)	11.50 (292)	6.48 (165)	35.69 (907)	8.00 (203)	0.27 (7)
HF463J, HF663J, HF663S	36.44 (926)	12.18 (309)	6.48 (165)	38.67 (982)	8.47 (215)	0.27 (7)
HF464J, HF664J, HF664S	49.48 (1257)	19.12 (486)	6.78 (172)	51.64 (1312)	13.44 (341)	0.33 (8)

**Figure 2, 4 & 6-Pole Non-fusible Type 12/3R and 4X**

HNF461J, HNF661J, HNF661S	24.50 (622)	9.53 (242)	6.48 (165)	26.65 (667)	5.47 (139)	0.27 (7)
HNF462J, HNF662J, HNF662S	24.88 (632)	11.50 (292)	6.48 (165)	27.03 (687)	8.00 (203)	0.27 (7)
HNF463J, HNF663J, HNF663S	27.54 (700)	12.18 (309)	6.48 (165)	29.77 (756)	8.47 (215)	0.27 (7)
HNF464J, HNF664J, HNF664S	36.00 (914)	19.12 (486)	6.78 (172)	38.16 (969)	13.44 (341)	0.33 (8)

4 SAFETY SWITCHES

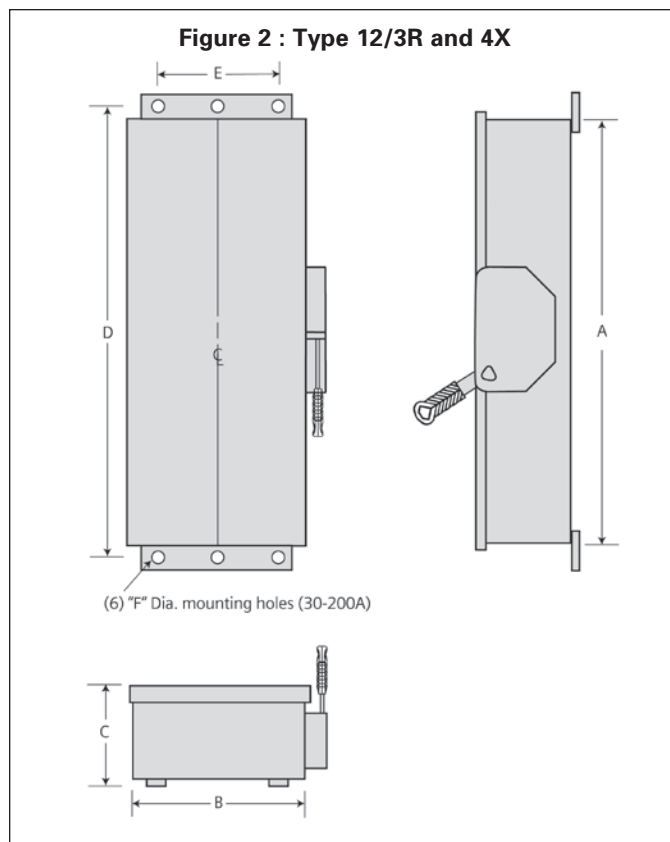
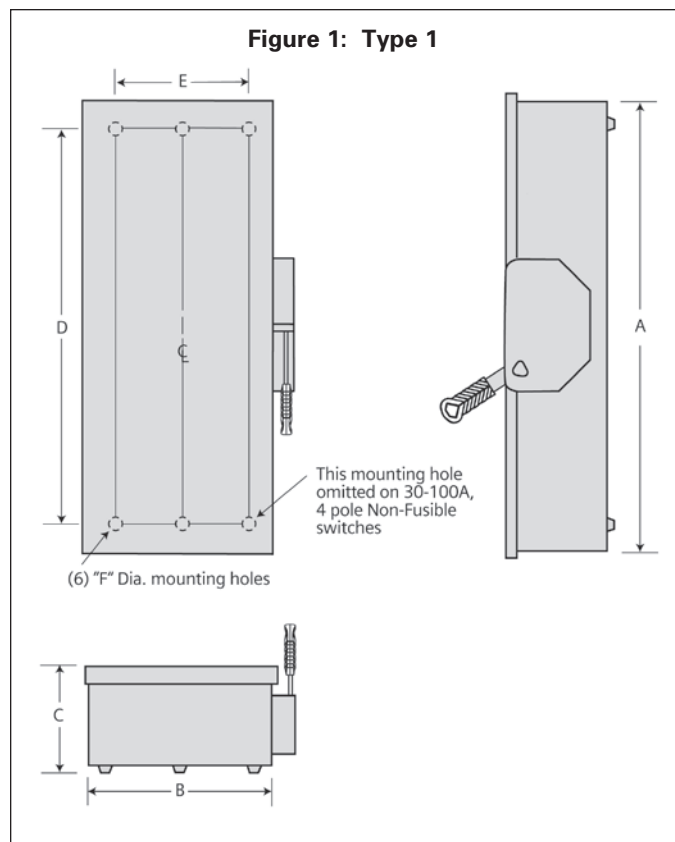

# Special Application Safety Switches Dimension Drawings

Double Throw

Selection

## Description

Double throw switches are intended to transfer loads from one power source to another. All 2 & 3-pole double throw switches are suitable for use as service equipment including non-fusible versions when used in combination with a UL listed circuit breaker or fusible switch. All are UL Listed and both horsepower and load break rated. Switches are rated for use on systems up to 10,000A when protected with Class H fuses or 100,000A when protected with Class R or Class T fuses<sup>②</sup>. They can also be used to connect a single source of power to either of two loads. In this application it is necessary to field modify fusible

switches so that the fuses are on the load side of the switching mechanism.

A cover interlock is provided on all ampere ratings. The operating handle may be padlocked in the off position.

### Fuse Capabilities of Fusible DTF Switches

Amp Rating	Fuse Type			
	H	R	T	J
30 & 60A, 240V	Std	Yes (kit)	No	No
30 & 60A, 600V	Std	Yes (kit)	No	Yes <sup>③</sup>
100 & 200A	Std	Yes (kit)	Yes (kit)	Yes <sup>③</sup>
400 & 600A (DTF)	No	No	Yes <sup>③</sup>	Std

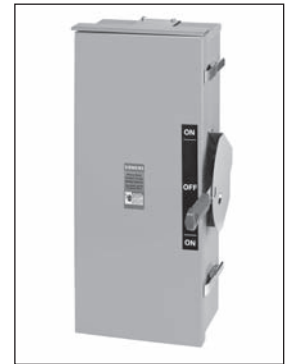

## Double Throw Switches

System	Voltage	Number of Poles	Amps	Type 1 — Indoor	Type 3R — Outdoor <sup>①</sup>	Type 12/3R — Industrial	Type 4X — Stainless Steel
				Catalog Number	Catalog Number	Catalog Number	Catalog Number

### Heavy Duty Fusible (30-200A) with Class H fuse spacings —Less Neutral<sup>②</sup>

	240 Volt AC or 250 Volt DC	2	200	DTF224▲	DTF224R	—	—	
			3	30	DTF321	DTF321R▲	—	—
				60	DTF322	DTF322R▲	—	—
		100		DTF323▲	DTF323R	—	—	
		3	200	DTF324	DTF324R	—	—	
			400	DTF325	FR325DTK <sup>④</sup> ▲	—	—	
	600		DTF326▲	FR326DTK <sup>④</sup> ▲	—	—		
	600 Volt AC, 250 Volt DC	3	30	DTF361	—	—	—	
			60	DTF362▲	—	—	—	
			100	DTF363	DTF363R	—	—	
		200	DTF364	DTF364R	—	F353SSDTK <sup>⑤</sup> ▲		
		400	DTF365	FR354SSDTK <sup>⑤</sup> ▲	—	F355SSDTK <sup>⑤</sup> ▲		
400		DTF365	FR355DTK <sup>④</sup> ▲	—	F355SSDTK <sup>⑤</sup> ▲			

### Heavy Duty Non-Fusible —Less Neutral<sup>②</sup>

	240 Volt AC or 250 Volt DC	2	30	DTNF221	—	—	—	
			3	60	DTNF222	—	—	—
				100	DTNF223	—	—	—
		200		DTNF224	DTNF224R	—	—	
		3	400	DTNF225	DTNF225R	—	—	
			30	DTNF321	—	—	—	
			60	DTNF322	—	—	—	
			100	DTNF323	DTNF323R	—	—	
			200	DTNF324	DTNF324R	—	—	
	400		DTNF325	—	—	—		
	600 Volt AC, or 250 Volt DC	3	600	DTNF326	—	—	—	
			800	DTNF327▲	—	—	—	
			30	DTNF361	DTNF361R	DTNF361J	DTNF361S	
		60	DTNF362	DTNF362R	DTNF362J	DTNF362S		
		100	DTNF363	DTNF363R	DTNF363J	DTNF363S		
		200	DTNF364	DTNF364R	DTNF364J▲	DTNF364S		
		400	DTNF365	DTNF365R	NF355HDTK	NF355SSDTK		
		600	DTNF366	DTNF366R	—	—		
800		DTNF367	DTNF367R	—	—			
4 <sup>⑤</sup>	1200	DTNF368▲	DTNF368R	—	—			
	30	—	NFR451DTK▲	—	—			
	60	—	NFR452DTK▲	—	—			
	100	—	NFR453DTK▲	—	—			
	200	NF454DTK	NFR454DTK▲	—	NF454SSDTK▲			
	400	NF455DTK▲	NFR455DTK▲	—	—			
600	NF456DTK▲	NFR456DTK▲	—	—				
800	NF457DTK▲	NFR457DTK▲	—	—				

### General Duty Non-Fusible

	Voltage	Number of Poles	Amps	Type 3R — Outdoor <sup>①</sup> Less Neutral	Type 3R — Outdoor <sup>①</sup> With Neutral	Type 3R — Outdoor General Duty With Neutral <sup>②</sup>
				Catalog Number	Catalog Number	Catalog Number
	240 Volt AC	2	100	DTGNF223R	DTGNF223NR	DTLNF213NR
			200	DTGNF224R	DTGNF224NR	—
	3	100	DTGNF323R	DTGNF323NR	—	
		200	DTGNF324R	DTGNF324NR	—	

▲ Built to order. Allow 3-4 weeks for delivery.

① Use HS Type hubs for 30-200A switches.

400A and larger switches do not have hub provisions.

② All Heavy Duty double throw switches with a catalog number starting with "DT" are rated 200,000 AIC max.

when protected by Class R, J or T fuses. Fuse ampere rating must not exceed switch ampere rating.

③ Move load base.

④ Will accept class T Fuses only.

⑤ 4-pole switches are not approved for service entrance.

⑥ Will accept class H fuses only.

⑦ General duty Stand-by Power Panel catalog number DTLNF213NR contains (2) 100A, 2P circuit breakers rated 120/240V AC & 10,000 AIC.

# Safety Switches

Double Throw

Selection

## Accessories, Lug Data and Horsepower Ratings

### Accessories – 2 and 3-Pole Switches Type “DT” Only<sup>Ⓞ</sup>

Description	Catalog Number	
<b>Neutral Kits</b>	30A 60 & 100A 200A 400 & 600A 800 & 1200A	HNC612 HN263 HNC264 HN678 HND678
<b>Equipment Ground Kit</b>	30-200A (2) #14-4 AWG 400 & 600A (4) #14-2/0 800-1200A (8) #6-350 Kcmil	HG61234 HG656 HG678
<b>Auxiliary Contacts (HD only) (two required per switch)<sup>Ⓞ</sup></b>	30-200A with (1) NO & (1) NC contact 30-200A with (2) NO & (2) NC contacts 400-1200A with (1) NO & (1) NC contact 400-1200A with (2) NO & (2) NC contacts	HA161234 HA261234 HA165678 HA265678
<b>Class R Fuse Clip Kits (two required per switch)</b>	30A, 240V Kit 30A, 600V Kit/60A, 240V Kit 60A, 600V Kit 100A Kit 200A Kit	HR21 HR612 HR62 HR63 HR64
<b>Class T Fuse Adapter Kits (two required per pole)</b>	100A, 240V Kit 100A, 600V Kit 200A, 240V Kit 200A, 600V Kit	HT23 HT63 HT24 HT64
<b>Type 3R Hubs (30-200A)</b>	For ¾" Conduit For 1" Conduit For 1 ½" Conduit For 2" Conduit For 2 ½" Conduit	ECHS075 ECHS100 ECHS125 ECHS150 ECHS200 ECHS250

### Accessories – 4-Pole and Type “F” & “NF” 3-Pole Switches Only<sup>Ⓞ</sup>

Description	Catalog Number	
<b>Auxiliary Switch (two required per switch)</b>	30-800A (1) NO, (1) NC <sup>Ⓞ</sup> (2) NO, (2) NC <sup>Ⓞ</sup>	DS200EK1 DS200EK2
<b>Ground Lug Kit<sup>Ⓞ</sup></b>	30-60-100A 200A 400-600-800A	DS100GK DS200GK DS468GK
<b>Hubs</b>	30-60-100A Use Type HR Hubs 200-400A Use Type SSH 4, 4X Hubs 600-800A Use Type SSH 4, 4X Hubs	
<b>Neutrals (3-pole only)</b>	30-60-100A 200A 400 & 600A Fusible 400A 3P Non-Fusible	DT100NK DT200NK DS800NK DT600NK

### Maximum Horsepower Ratings

#### Fused

Ampere Rating	1-Phase AC		3-Phase AC			250V DC
	240V	240V	480V	600V	600V	
30	3	7½	15	20	5	
60	10	15	30	50	10	
100	15	30	60	75	20	
200	15	60	125	150	40	
400	—	125	125	125	50	
600	—	125	—	—	50	

#### Non-Fused

30	5	10	20	30	5
60	10	20	50	60	10
100	15	40	75	100	20
200	15	60	125	150	40
400-800	—	125	250	350	50

▲ Built to order. Allow 6-8 weeks for delivery.

Ⓞ For “DT” VBII Type switches only.

Ⓞ Also for fusible stainless & 400A Type 12 & 4x switches.

Ⓞ The following ground lugs are provided as standard in 200A and larger switches 200-(1) #14-4 Cu/Al 400-800A-(3) #6-250MCM Cu/Al.

Ⓞ One aux. required for normal and one required for emergency switch line base.

### Wire Ranges (Line, Load and Neutral) per NEC Requirements

#### 30-200A – 2, 3 & 4-Pole Switches

Switch Ampere Rating	Wire Range (Cu/Al) New VBII Design Line, Load and Neutral
30	(1) #14-6
60	(1) #14-2
100	(1) #14-1/0 AWG
100	(1) #14-1/0 AWG
200	(1) #6-250 kcmil

#### 400-1200A – 2 & 3-Pole Switches

Switch Ampere Rating	Wire Range (Cu/Al) New VBII Design Line, Load and Neutral
400	(1) 1/0 AWG-750 kcmil or (2) 1/0 AWG-250 kcmil
600	(2) 1/0 AWG-500 kcmil
800	(2) 1/0 AWG-750 kcmil or (3) 1/0 AWG-500 kcmil
1200	(3) 1/0 AWG-600 kcmil or (4) 1/0 AWG-500 kcmil

#### 400-800A – 4-Pole switches

Switch Ampere Rating	Wire Range (Cu/Al) New VBII Design Line, Load and Neutral
400	(2) 1/0 AWG-300 kcmil or (1) 1/0 AWG-750 kcmil
600	(2) 250-500 Kcmil
800	(3) 250-500 Kcmil

### Replacement Parts – 2 and 3-Pole Switches Only<sup>Ⓞ</sup>

Description	Catalog Number
Type 1, 3R & 12 Replacement Handle	30-200A HHD61234
Type 4X Replacement Handle	30-200A HHD61234S
Replacement Handle	400-1200A HHD656

# Safety Switches

Double Throw

Dimensions

## VIII Design Double Throw Dimensions (Inches)

Catalog Number	Enclosure			Mounting		
	A	B	C	D	E	F
<b>Figure 1 (30-1200A Type 1 &amp; 3R)</b>						
DTNF221, DTNF321, DTNF361, DTNF361R	24.50	9.53	6.09	19.00	6.75	0.268
DTF321, DTF321R, DTF361	29.12	9.53	6.09	23.50	6.75	0.268
DTNF222, DTNF322, DTNF362, DTNF362R	24.88	11.50	6.09	19.00	9.38	0.268
DTF322, DTF322R, DTF362	33.45	11.50	6.09	27.50	9.38	0.268
DTNF223, DTNF323, DTNF323R, DTNF363, DTNF363R, DTGNF223R, DTGNF223NR, DTGNF323R, DTGNF323NR	27.62	12.18	6.09	19.36	8.00	0.268
DTF323, DTF323R, DTF363, DTF363R	36.44	12.18	6.09	28.11	8.00	0.268
DTNF224, DTNF224R, DTNF324, DTNF324R, DTNF364, DTNF364R, DTGNF224R, DTGNF224NR, DTGNF324R, DTGNF324NR	36.00	19.12	6.42	31.00	15.00	0.44
DTF224, DTF224R, DTF324, DTF324R, DTF364, DTF364R	49.44	19.12	6.42	44.50	15.00	0.44
DTF325, DTF326, DTF365	73.54	28.22	9.44	65.50	16.00	0.56
DTNF225, DTNF225R, DTNF325, DTNF365, DTNF365R	57.71	28.22	9.44	49.75	16.00	0.56
DTNF326, DTNF366, DTNF366R	57.71	28.22	9.44	49.75	16.00	0.56
DTNF327, DTNF367, DTNF367R	71.65	41.60	9.44	63.70	32.00	0.56
DTNF368, DTNF368R	71.65	41.60	9.44	63.70	32.00	0.56
FR325DTK <sup>Ⓞ</sup> , FR355DTK <sup>Ⓞ</sup>	74.31	24.90	8.88	69.50	20.25	0.56
FR326DTK <sup>Ⓞ</sup>	85.65	27.00	8.88	80.75	22.25	0.56
NFR451DTK <sup>Ⓞ</sup> , NFR452DTK <sup>Ⓞ</sup> , NFR453DTK <sup>Ⓞ</sup>	24.63	17.34	4.78	21.50	14.97 <sup>Ⓢ</sup>	0.27 <sup>Ⓢ</sup>
NF454DTK <sup>Ⓞ</sup> , NFR454DTK <sup>Ⓞ</sup>	37.25	19.19	6.32	33.50	16.00 <sup>Ⓢ</sup>	0.56 <sup>Ⓢ</sup>
NF455DTK <sup>Ⓞ</sup> , NF456DTK <sup>Ⓞ</sup> , NF457DTK <sup>Ⓞ</sup> , NFR455DTK <sup>Ⓞ</sup> , NFR456DTK <sup>Ⓞ</sup> , NFR457DTK <sup>Ⓞ</sup>	63.31	27.00	8.88	58.50	22.25 <sup>Ⓢ</sup>	0.56 <sup>Ⓢ</sup>
<b>Figure 2 (30-200A Type 12 &amp; 4X)</b>						
DTNF361J, DTNF361S	24.42	9.65	6.48	26.65	5.47	0.27
DTNF362J, DTNF362S	24.80	11.61	6.48	27.03	8.00	0.27
DTNF363J, DTNF363S	27.54	12.29	6.48	29.77	8.47	0.27
DTNF364J, DTNF364S	35.93	19.24	6.78	38.16	13.44	0.33
NF355HDTK <sup>Ⓞ</sup> , NF355SSDTK <sup>Ⓞ</sup>	53.82	22.66	7.25	56.20	18.00	0.56
NF454SSDTK <sup>Ⓞ</sup>	37.47	19.16	6.48	39.75	15.75	0.50 <sup>Ⓢ</sup>
F353SSDTK <sup>Ⓞ</sup>	37.00	11.62	5.50	38.50	9.00	0.26
F354SSDTK <sup>Ⓞ</sup>	50.90	19.16	6.46	53.27	16.12	0.50
F355SSDTK <sup>Ⓞ</sup>	74.50	25.00	8.92	76.69	20.25	0.56

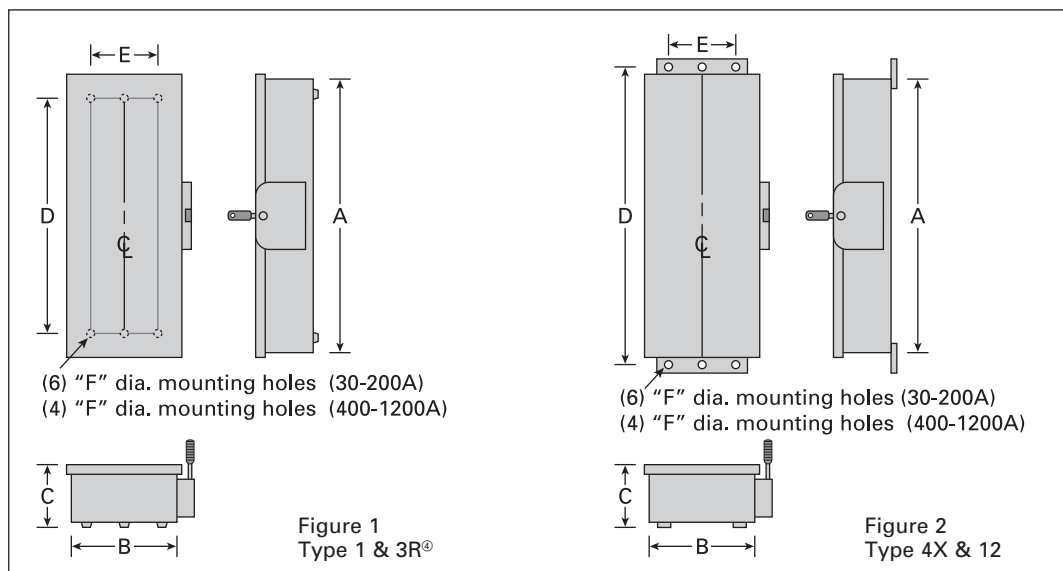

\*For inches / millimeters conversion, multiply inches by 25.4.

Ⓞ (3) Mounting holes supplied (1 at top).  
 Ⓢ (4) Mounting holes provided.

Ⓞ These switches are not Type VIII design.  
 Ⓢ Drip hood not shown but provided on Type 3R enclosures.

# Enclosed Rotary Switches

## 3LD2 Rotary Disconnect Switches in Non-Metallic Enclosures

Selection

### Description

16–125A non-fusible switches are available in fiberglass reinforced polycarbonate enclosures which are UL approved as Type 12 & 4X and for either indoor or outdoor use. All are horsepower and load break rated. All are panel mounted and are either supplied with factory installed aux. contacts or will accept contact kits. All are compact in size while providing ample wiring space for copper line & load conductors.

### Siemens Enclosed Rotary Disconnect Switches

- 16–125A, Non-Fusible
- 600VAC max. rated
- Available in both Type 12 and 4X non-metallic enclosures
- Listed and marked “suitable for use as motor disconnect” per NEC Section 430-109
- Switches are UL listed under File No. E47705 and are CSA certified under File No. 203576
- IEC 60947-3 rated and CE marked (enclosures are IP65 rated)
- HP rated
- 16–63A switches have factory installed ground bars.
- Switches are provided with knockouts
- Padlockable in OFF position with up to (3) padlocks
- Enclosures are constructed from Makrolon 9425.

Amp Rating	Catalog Number		Shipping Weight <sup>①</sup>	Horsepower Ratings			
	3 Pole, 3 Wire	3 Pole, 3 Wire with (1) NO & (1) NC Aux. Contact <sup>②③</sup>		240V AC		480V AC	600V AC
				1 Phase	3 Phase	3 Phase	3 Phase

#### Non-Fusible, Type 1, 4X & 12K<sup>®</sup> with Black Rotary Handle 600V AC Max.

16	3LD2064-0TB51-0US2	3LD2064-1GP51-0US2	1	1½	3	7½	10
25	3LD2164-0TB51-0US2	3LD2164-1GP51-0US2	1	3	7½	10	15
30	3LD2264-0TB51-0US2	3LD2264-1GP51-0US2	1	3	7½	15	20
30	—	3LD2264-1TS51-0US2 <sup>④▲</sup>	1	3	7½	15	20
30	—	3LD2264-2TW51-0US2 <sup>④▲</sup>	1	3	7½	15	20
63	3LD2565-0TB51-0US2	3LD2565-1GP51-0US2▲	3	10	15	40	50
100	3LD2766-0TB51-0US2	3LD2766-1GP51-0US2▲	6	—	30	60	75
125	3LD2866-0TB51-0US2	3LD2866-1GP51-0US2▲	6	—	40	75	100

#### Non-Fusible, Type 1, 4X & 12K<sup>®</sup> with Red and Yellow Rotary Handle 600V AC Max.

16	3LD2064-0TB53-0US2	3LD2064-1GP53-0US2	1	1½	3	7½	10
25	3LD2164-0TB53-0US2	3LD2164-1GP53-0US2	1	3	7½	10	15
30	3LD2264-0TB53-0US2	3LD2264-1GP53-0US2	1	3	7½	15	20
30	—	3LD2264-1TS53-0US2 <sup>④▲</sup>	1	3	7½	15	20
30	—	3LD2264-2TW53-0US2 <sup>④▲</sup>	1	3	7½	15	20
63	3LD2565-0TB53-0US2	3LD2565-1GP53-0US2▲	3	10	15	40	50
100	3LD2766-0TB53-0US2▲	3LD2766-1GP53-0US2▲	6	—	30	60	75
125	3LD2866-0TB53-0US2▲	3LD2866-1GP53-0US2▲	6	—	40	75	100

▲ Built to order. Allow 6–8 weeks for delivery.

① Carton quantity of (1). Shipping weight in pounds (lbs.).

② Approved for indoor/outdoor use. No cover interlock provided.

③ Switch is supplied with (2) NO and no NC aux. contacts.

④ Switch is supplied with (4) NO and no NC aux. contacts.

Ground bar is not provided or available.

⑤ Aux. contacts break about 3 Ms before and make about 3 Ms after main switch contacts.

⑥ 6P, 25A, switch with 1 NO & 1 NC aux. contacts and a black operating handle is also available. Order catalog number **3LD2165-4VD51** (Discount Code: Pilot Devices).

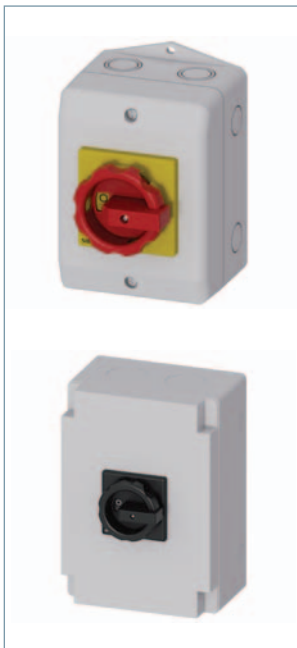

# Enclosed Rotary Switches

## 3LD2 Rotary Disconnect Switches in Non-Metallic Enclosures

Selection

### Enclosed Disconnect Switch Dimensions (Inches)

Catalog Number	Ampere Rating	Dimensions			
		A	B	C	D
3LD2064-	16	5.52 <sup>③</sup>	3.94	3.19	4.57
3LD2164-	25	5.52 <sup>③</sup>	3.94	3.19	4.57
3LD2264-	30	5.52 <sup>③</sup>	3.94	3.19	4.57
3LD2565-	63	6.93 <sup>③</sup>	5.75	4.10	5.87
3LD2766-	100	11.90	8.35	5.36	7.13
3LD2866-	125	11.90	8.35	5.36	7.13

Note: 3LD2 Type switches only have top and bottom end KOs as follows:  
16-30A - 1/2" & 3/4", 63A - 3/4" & 1", 100 & 25A - 1" & 1 1/4"

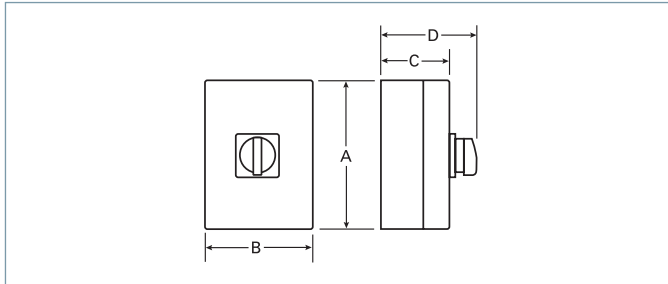

### UL and CUL Short Circuit Withstand Ratings<sup>③</sup>

Ampere Rating	Short Circuit Withstand Rating and Fuse Class				
	With Line Side Fusing			With Load Side Fusing <sup>①</sup>	
	5 kA at 600V Max	10 kA at 600V Max	18 kA at 480V Max	5 kA at 480V Max	18 kA at 480V Max
16	RK5 (50A Max)	—	—	—	—
25 & 30	RK5 (80A Max)	—	—	—	—
63	RK5 (175A Max)	—	—	—	—
100 & 125	—	RK5 (200A Max)	—	—	—

<sup>①</sup> For use as supplemental protection on the load side of the branch circuit over current protective device.  
<sup>②</sup> Factory installed ground lugs supplied as follows: 16-30A #14-10 Cu, 63A #14-8 Cu. Ground lug not provided and is not available on catalog numbers 3LD2264-2TW51-0US2 and 3LD2264-2TW53-0US2.

### Wire ranges 60/75°C Cu Only<sup>②</sup>

16 Amps	(1) #18-10 AWG
25-30 Amps	(1) #14-10 AWG
63 Amps	(1) #14-6 AWG
100-125 Amps	(1) #12-1 AWG

### IEC Fuse and Withstand Ratings

Ampere Rating	gG Fuse Size	Short Circuit Rating
16	20A	5k Arms
25	25A	10k Arms
32	50A	10k Arms
63	63A	15k Arms
100	100A	20k Arms
125	125A	20k Arms

### Accessories<sup>②</sup>

Switch Ampere Rating	Catalog Number	Description
16-30A	3LD9220-2C	Neutral Kit
63A	3LD9250-2CA	Neutral Kit
100-125A	3LD9280-2C	Neutral Kit

<sup>③</sup> 6.38 inches high including mounting feet.  
<sup>④</sup> 7.85 inches high including mounting feet.  
<sup>⑤</sup> 16-63A 3LD switches are also rated 5kA at 600VAC max when protected by a 3RV type MSP of the same or lesser ampere rating.

# Enclosed Switches

## Enclosed Bolted Pressure Switches & Safety Switch Replacement Parts

Selection

For enclosed bolted pressure contact switches order as lug-in/lug-out single section BPS main switchboards using either the SPACE 2000 Switchboard EPM or COMPAS.

### VBII Safety Switch Replacement Parts

Ampere Rating	Line Base	Load Base	Handle / Handle Guard	
	Catalog Number	Catalog Number	General Duty	Heavy Duty

#### Fusible 2- and 3-Pole 60-600A General Duty & 30-1200A Heavy Duty<sup>⑤⑧</sup>

30 HD 240V	HFB21 <sup>②</sup>	HBB21 <sup>②</sup>	—	HH6123 <sup>⑦</sup>
60 GD	HFB612 <sup>②</sup>	HBB612 <sup>②</sup>	GH223	—
60 HD 240V	HFB22 <sup>②</sup>	HBB22 <sup>②</sup>	—	HH6123 <sup>⑦</sup>
30 600V	HFB612 <sup>②</sup>	HBB612 <sup>②</sup>	—	HH6123 <sup>⑦</sup>
60 600V	HFB62 <sup>②</sup>	HBB62 <sup>②</sup>	—	HH6123 <sup>⑦</sup>
100	HFB63 <sup>②</sup>	HBB63 <sup>②</sup>	GH223	HH6123 <sup>⑦</sup>
200	HFB64 <sup>②</sup>	HBB64 <sup>②</sup>	GH24	HH64 <sup>⑦</sup>
400 (Legacy)	HFB65 <sup>③④</sup>	HBB656 <sup>③④</sup>	HH65678	HH65678 <sup>⑦</sup>
400 (Series-A)	HFB65A	HBB65A	HH656A	HH656A
600 (Legacy)	HFB66 <sup>③④</sup>	HBB656 <sup>③④</sup>	HH65678	HH65678 <sup>⑦</sup>
600 (Series-A)	HFB66A	HBB66A	HH656A	HH656A
800	HFB67A <sup>②⑥</sup>	HBB67A <sup>②⑥</sup>	—	HH65678 <sup>⑦</sup>
1200	HFB68 <sup>②⑥</sup>	HBB68 <sup>②⑥</sup>	—	HH68 <sup>⑦</sup>

#### Non-Fusible 3-Pole 60-600A General Duty & 30-1200A Heavy Duty<sup>⑤⑧</sup>

30 HD	HNB612 <sup>②</sup>	—	—	HH6123 <sup>⑦</sup>
60 GD	HNB612 <sup>②</sup>	—	GH223	—
60 HD	HNB623 <sup>②</sup>	—	—	HH6123 <sup>⑦</sup>
100	HNB623 <sup>②</sup>	—	GH223	HH6123 <sup>⑦</sup>
200	HNB64 <sup>②</sup>	—	GH24	HH64 <sup>⑦</sup>
400 (Legacy)	HNB65 <sup>③④</sup>	—	HH65678	HH65678 <sup>⑦</sup>
400 (Series-A)	HNB656A	—	HH656A	HH656A
600 (Legacy)	HNB66 <sup>③④</sup>	—	HH65678	HH65678 <sup>⑦</sup>
600 (Series-A)	HNB656A	—	HH656A	HH656A
800	HNB67A <sup>②⑥</sup>	—	—	HH65678 <sup>⑦</sup>
1200	HNB678 <sup>②</sup>	—	—	HH68 <sup>⑦</sup>

Ampere Rating	Mechanism Assembly Catalog Number	Line & Load Lugs Catalog Number
---------------	-----------------------------------	---------------------------------

#### Fusible 2- and 3-Pole 60-600A General Duty & 30-1200A Heavy Duty<sup>⑤⑧</sup>

30 HD 240V	HM6123 <sup>⑦</sup>	HL612 <sup>①</sup>
60 GD	HM6123	HL612 <sup>①</sup>
60 HD 240V	HM6123 <sup>⑦</sup>	HL612 <sup>①</sup>
30 600V	HM6123 <sup>⑦</sup>	HL612 <sup>①</sup>
60 600V	HM6123 <sup>⑦</sup>	HL612 <sup>①</sup>
100	HM6123 <sup>⑦</sup>	HL63 <sup>①</sup>
200	HM64 <sup>⑦</sup>	HL64 <sup>①</sup>
400 (Legacy)	HM65	HL65678 <sup>②</sup>
400 (series-A)	HM656A	HL656A <sup>⑩</sup>
600 (Legacy)	HM66	HL65678 <sup>②</sup>
600 (series-A)	HM656A	HL66A <sup>⑩</sup>
800	HM67A	⑨
1200	HM678	⑨

#### Non-Fusible 3-Pole 60-600A General Duty & 30-1200A Heavy Duty<sup>⑤⑧</sup>

30 HD	HM6123 <sup>⑦</sup>	HL612 <sup>①</sup>
60 GD	HM6123	HL612 <sup>①</sup>
60 HD	HM6123 <sup>⑦</sup>	HL612 <sup>①</sup>
100	HM6123 <sup>⑦</sup>	HL63 <sup>①</sup>
200	HM64 <sup>⑦</sup>	HL64 <sup>①</sup>
400 (Legacy)	HM65	HL65678 <sup>②</sup>
400 (series-A)	HM656A	HL656A <sup>⑩</sup>
600 (Legacy)	HM66	HL65678 <sup>②</sup>
600 (series-A)	HM656A	HL656A <sup>⑩</sup>
800	HM67A	⑨
1200	HM678	⑨

### Internal Shield Kits

These kits provide an inner door on safety switches to prevent accidental contact with live parts. All kits are constructed from clear plastic, provide test probe holes and allow replacement of fuses without the removal of the kit.

Catalog Number	Switch Ampere Rating	UPC Code 040892_
----------------	----------------------	------------------

#### For use with Fusible Type 1, 3R, 12 and 4X Stainless Steel Enclosed Safety Switches<sup>⑩</sup>

HSK61SSW	30	79020
HSK62SSW	60	79021
HSK63SSW	100	79002
HSK64SSW	200	79023

#### For use with Fusible Type VBII Disconnect Switches

HSK61	30	79024
HSK623	60 & 100	79025
HSK64	200	79026

- ① Three lugs included in kit.
- ② Includes lugs.
- ③ Lugs not included.
- ④ One lug per kit.
- ⑤ One per switch required unless otherwise noted.
- ⑥ One required per pole.
- ⑦ For type 4/4X stainless steel switches add "S" to end of catalog number.

- ⑧ For replacement door for heavy duty switches add "DOOR" to end of switch catalog number.
- ⑨ Lugs included with base only, not available separately.
- ⑩ Not for use with Non-metallic safety switches.
- ⑪ Lug caps only—2 line side caps and 2 load side caps per kit.



HF362 with HSK62SSW installed



VBFS361F with HSK61 Installed