

# Product datasheet

Specifications



## TeSys F contactor - 3P (3 NO) - AC-3 - $\leq 440$ V 1000 A - coil 220 V DC

LC1F1000MD

### Main

Range	TeSys
Range of product	TeSys F
Product or component type	Contacteur
Device short name	LC1F
Contacteur application	Resistive load Motor control
Utilisation category	AC-3 AC-1
Poles description	3P
[Ue] rated operational voltage	$\leq 440$ V AC 50/60 Hz
[Uc] control circuit voltage	220 V DC
[Ie] rated operational current	1250 A (at $\leq 40$ °C) at $\leq 440$ V AC AC-1 1000 A (at $\leq 55$ °C) at $\leq 440$ V AC AC-3

### Complementary

[Uimp] rated impulse withstand voltage	8 kV
[Ith] conventional free air thermal current	1250 A (at 40 °C)
Rated breaking capacity	8 kA conforming to IEC 60947-4-1
[Icw] rated short-time withstand current	10000 A 40 °C - 10 s 7500 A 40 °C - 30 s 5500 A 40 °C - 1 min 4200 A 40 °C - 3 min 3000 A 40 °C - 10 min
Associated fuse rating	1400 A gG at $\leq 440$ V
Average impedance	0.1 mOhm - Ith 1250 A 50 Hz
[Ui] rated insulation voltage	1000 V conforming to IEC 60947-4-1 1500 V conforming to VDE 0110 group C
Power dissipation per pole	200 W AC-1
Overvoltage category	III
power pole contact composition	3 NO
Maximum operating rate	600 cyc/h 55 °C
Operating time	40...80 ms closing 100...200 ms opening

Excluding VAT, FCA Jabal Ali & are subject to change – check with your local distributor.

<b>Connections - terminals</b>	Control circuit: screw clamp terminals 1 cable(s) 1...4 mm <sup>2</sup> flexible without cable end Control circuit: screw clamp terminals 2 cable(s) 1...4 mm <sup>2</sup> flexible without cable end Control circuit: screw clamp terminals 1 cable(s) 1...4 mm <sup>2</sup> flexible with cable end Control circuit: screw clamp terminals 2 cable(s) 1...2.5 mm <sup>2</sup> flexible with cable end Control circuit: screw clamp terminals 1 cable(s) 1...4 mm <sup>2</sup> solid without cable end Control circuit: screw clamp terminals 2 cable(s) 1...4 mm <sup>2</sup> solid without cable end Power circuit: bar 3 cable(s) Power circuit: bar 4 cable(s)
<b>Mounting support</b>	Plate
<b>motor power range</b>	315 kW at 220...230 V 3 phases 560 kW at 380...400 V 3 phases 630 kW at 415 V 3 phases 670 kW at 440 V 3 phases
<b>Motor starter type</b>	Direct on-line contactor
<b>Contactor coil voltage</b>	220 V DC standard
<b>Standards</b>	IEC 60947-4-1 IEC 60947-1 EN 60947-1 EN 60947-4-1
<b>Product certifications</b>	CCC CSA CB
<b>Compatibility code</b>	LC1F
<b>Control circuit type</b>	DC standard

## Environment

<b>IP degree of protection</b>	IP20 front face with shrouds conforming to IEC 60529 IP20 front face with shrouds conforming to VDE 0106
<b>Protective treatment</b>	TH
<b>Ambient air temperature for operation</b>	-5...40 °C
<b>Ambient air temperature for storage</b>	-60...80 °C
<b>Permissible ambient air temperature around the device</b>	-40...60 °C
<b>Height</b>	332 mm
<b>Width</b>	438 mm
<b>Depth</b>	238.6 mm
<b>Operating altitude</b>	3000 m without derating
<b>Net weight</b>	31 kg

## Packing Units

<b>Unit Type of Package 1</b>	PCE
<b>Number of Units in Package 1</b>	1
<b>Package 1 Height</b>	36.1 cm
<b>Package 1 Width</b>	48.3 cm
<b>Package 1 Length</b>	60.3 cm
<b>Package 1 Weight</b>	23 kg

## Contractual warranty

<b>Warranty (in months)</b>	18
-----------------------------	----



## Environmental Data

Schneider Electric aims to achieve Net Zero status by 2050 through supply chain partnerships, lower impact materials, and circularity via our ongoing “Use Better, Use Longer, Use Again” campaign to extend product lifetimes and recyclability.

[Environmental Data explained >](#)

[How we assess product sustainability >](#)



### Environmental footprint

Environmental Disclosure

[Product Environmental Profile](#)

## Use Better



### Materials and Substances

EU RoHS Directive

[Compliant](#)

## Use Longer



### Lifetime extension

Repair

No

## Use Again



### Repack and remanufacture

End of life manual availability

[End of Life Information](#)

WEEE Label



The product must be disposed on European Union markets following specific waste collection and never end up in rubbish bins

Dimensions Drawings

Dimensions and Drawings

LC1 F1000

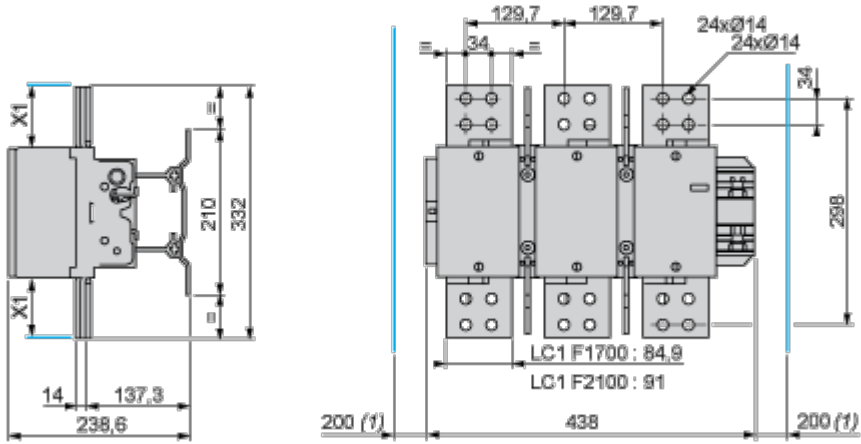

(1) Minimum distance required for coil removal.

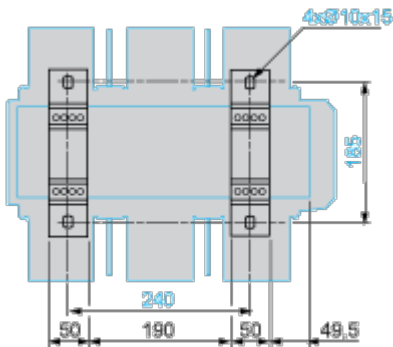

**NOTE:** X1 (mm) = Minimum electrical clearance according to operating voltage and breaking capacity.

Voltage	200...500 V	690...1000 V
X1 (mm)	90	100