

Analog signal converters CC-E I/I

Current / current isolators

The CC-E I/I is an isolator for the electrical isolation of current signals without auxiliary supply. It allows the isolation between sensors, transmitters, actuators etc. and the signal receivers.



2CDC 281 001 F0006

2CDC 281 041 F0003

Features

- Loop-powered I/I isolator without external power supply for analog current signals of 0-20 mA and 4-20 mA
- Electrical isolation between input and output
- Very low internal voltage drop ≤ 2.5 V
- Available with one or two independent channels
- Width only 18 mm (1 and 2 channels)

Approvals

 UL 508, CAN/CSA C22.2 No.14

Marks

 CE

 C-Tick

Order data

Type	Number of channels	Order code
CC-E I/I	1 channel	1SVR 010 200 R1600
CC-E I/I	2 channels	1SVR 010 201 R0300

Functions

Application

The CC-E I/I is an isolator for the electrical isolation of current signals without auxiliary supply. It allows the isolation between sensors, transmitters, actuators etc. and the signal receivers (see "Connection and wiring" on page 3).

Operating mode

One of the most important characteristics of the CC-E I/I is the internal voltage drop of $\leq 2.5\text{ V}$ and the burden to be driven by the input current source.

Calculation of the max. output load R_L of the isolator CC-E I/I depends on the max. load to be connected to the input current source:

Most current sources are designed to drive a load between $20\ \Omega$ and $500\ \Omega$. In our example, a value of $500\ \Omega$ is used, which can be driven by the current source connected to the input of the isolator.

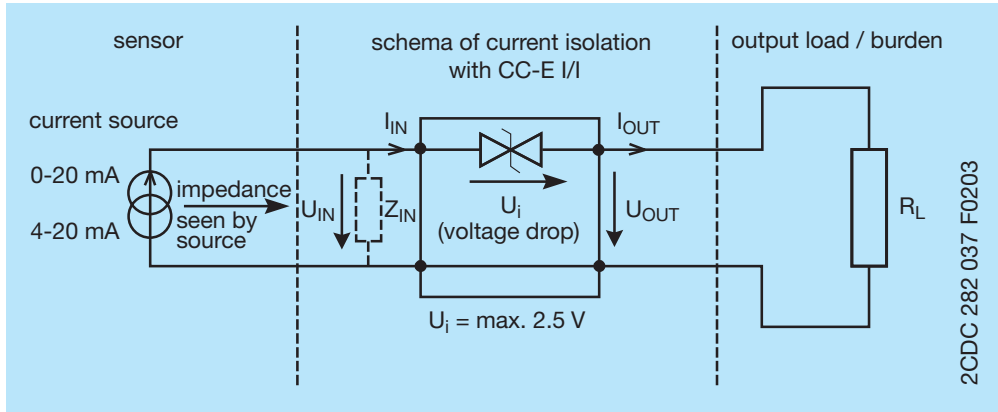

The burden to be driven by the input current source is the input impedance (Z_{IN}) of the isolator CC-E I/I. Z_{IN} will vary with the output load as follows:

$$Z_{IN} = R_L + U_{IN} / I$$

$$Z_{IN} = 500\ \Omega \text{ (max. load, which the input current source can drive)}$$

$$R_L = Z_{IN} - U_{IN} / I$$

$$R_L = 500\ \Omega - U_{IN} / I$$

this means that

$I = 20\text{ mA}$ and $U_i = 2.5\text{ V}$ is followed by:

$$R_L = 500\ \Omega - 2.5\text{ V} / 20\text{ mA}$$

$$R_L = 375\ \Omega$$

In this example, the CC-E I/I can drive a maximum output load R_L of $375\ \Omega$. If the input burden to be driven is larger, the input current source must be increased. At a maximum output load of $R_L = 500\ \Omega$ of the isolator CC-E I/I, the input current source is loaded with $625\ \Omega$.

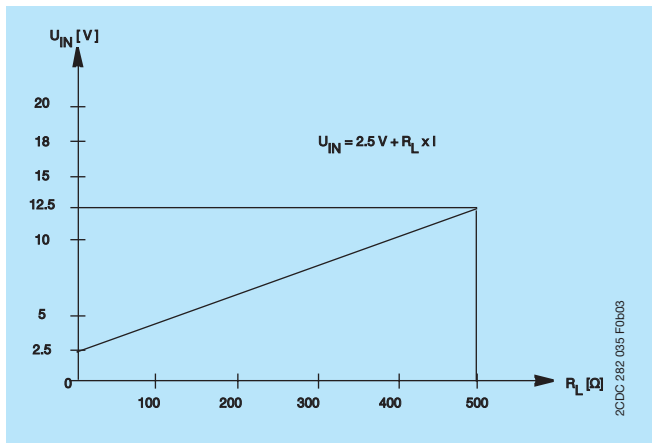

Input voltage depending on the output load R_L at $I = 20\text{ mA}$

Connection and wiring

Position of connecting terminals

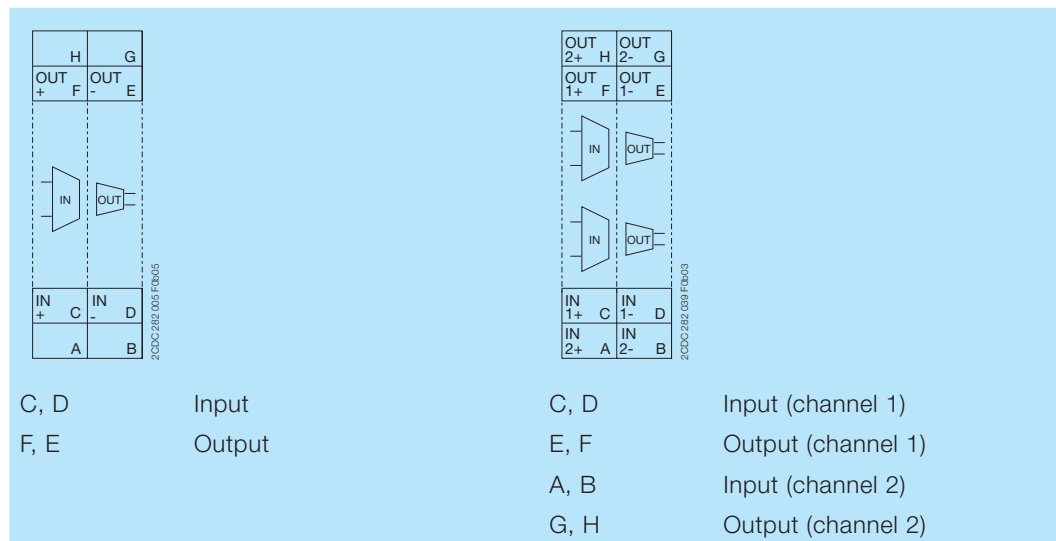

Version: 1 channel
(1SVR 010 200 R1600)

Version: 2 channels
(1SVR 010 201 R0300)

Wiring instructions

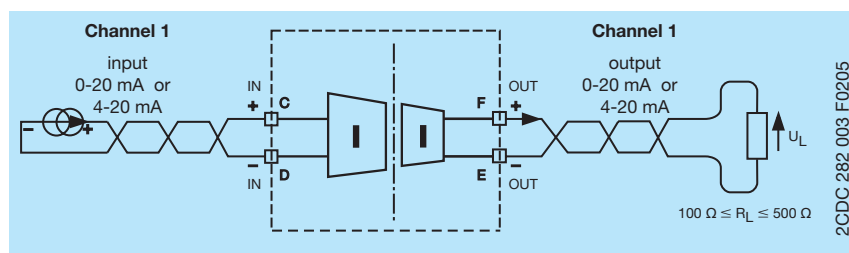

CC-E I/I 1 channel

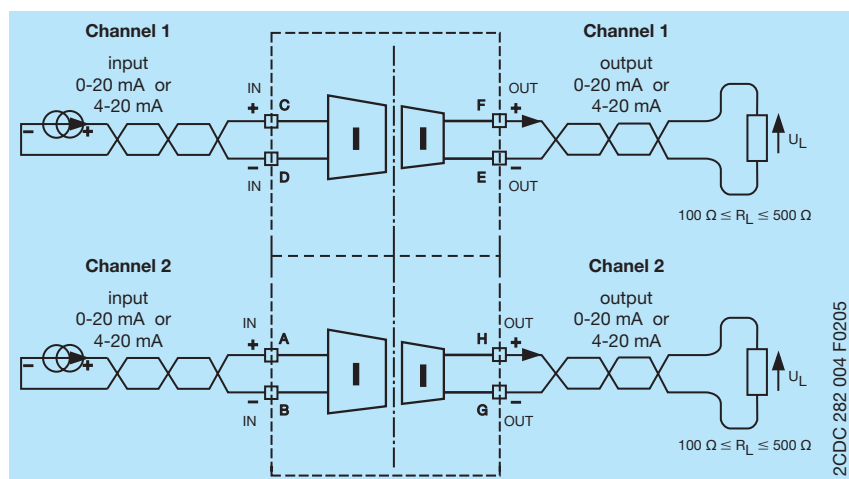

CC-E I/I 2 channels

Technical data

Input circuit - Analog inputs		
Input current I_{IN}		0-20 mA, 4-20 mA
Min. input current		> 100 μ A
Max. input current	$U_{IN} < 18$ V	50 mA ¹⁾
Input voltage U_{IN}		< 2.5 V + ($I_{IN} \times R_L$)
Input voltage drop U_i	20 mA, $R_L = 0 \Omega$	< 2.5 V
Max. input voltage	$I_{IN} < 50$ mA	18 V ¹⁾
Output circuit		
Output current I_{OUT}		0-20 mA, 4-20 mA
Output load R_L		0-500 Ω
Output voltage U_{OUT}		$I_{out} \times R_L$
Residual ripple	500 Ω , 20 mA	< 20 mV _{pp}
Response time (0-100 %)	0-500 Ω , 20 mA	< 15 ms
	500 Ω , 20 mA, 25 °C	< 5 ms
Accuracy		≤ 0.1 % of full-scale (20 mA)
Load influence (0-500 Ω)		$\leq \pm 0.05$ % / 100 Ω
		≤ -0.1 % / 100 Ω (25 °C)
General data		
Width of the enclosure		18 mm
Weight	1 channel	ca. 0.037 kg (0.082 lb)
	2 channels	ca. 0.044 kg (0.097 lb)
Mounting position		any
Degree of protection	enclosure / terminals	IP20 / IP20
Ambient temperature range	operation	-25 °C ... +60 °C
	storage	-40 °C ... +85 °C
Temperature coefficient		< ± 50 ppm / °C
Mounting		DIN rail (IEC/EN 60715)
Operational reliability	IEC/EN 68-2-6	4 g
Mechanical resistance	IEC/EN 68-2-6	10 g
Environmental testing	IEC/EN 68-2-30 Db	24 h cycle, 55 °C, 93 % rel., 96 h
Electrical connection		
Wire size	rigid	0.2-4 mm ² (24-12 AWG)
	fine-strand with(out) wire end ferrule	0.2-2.5 mm ² (24-14 AWG)
Stripping length		7 mm (0.28 in)
Tightening torque		0.5 Nm (4.4 lb.in)
Isolation data		
Insulation voltage input / output		500 V _{eff} / 50 Hz
Insulation voltage between channels	device with 2 channels	5 kV _{eff} / 50 Hz
Pollution category		2
Overvoltage category		II

¹⁾ The input parameters have to be limited to the indicated maximum values.

Standards / directives

Product standard	EN 50178
Low Voltage Directive	2006/95/EC
EMC Directive	2004/108/EC

Electromagnetic compatibility

Interference immunity to		IEC/EN 61000-6-2
electrostatic discharge	IEC/EN 61000-4-2	Level 3, ± 6 kV / ± 8 kV
radiated, radio-frequency, electromagnetic field	IEC/EN 61000-4-3	10 V/m
electrical fast transient / burst	IEC/EN 61000-4-4	Level 3, ± 2 kV / 5 kHz
surge	IEC/EN 61000-4-5	± 2 kV / ± 1 kV
conducted disturbances, induced by radio-frequency fields	IEC/EN 61000-4-6	10 V
power frequency magnetic field	IEC/EN 61000-4-8	30 A/m
Interference emission		IEC/EN 61000-6-4
Radiated noise	EN 55011	Class B

Dimensions

in mm and inches

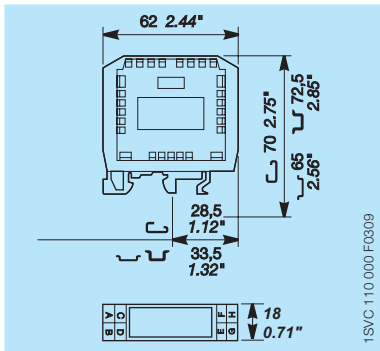

Contact us

ABB STOTZ-KONTAKT GmbH

P. O. Box 10 16 80
69006 Heidelberg, Germany
Phone: +49 (0) 6221 7 01-0
Fax: +49 (0) 6221 7 01-13 25
E-mail: info.desto@de.abb.com

You can find the address of your
local sales organisation on the
ABB home page
<http://www.abb.com/contacts>
-> Low Voltage Products and Systems

Note:

We reserve the right to make technical changes or modify the contents of this document without prior notice. With regard to purchase orders, the agreed particulars shall prevail. ABB AG does not accept any responsibility whatsoever for potential errors or possible lack of information in this document.

We reserve all rights in this document and in the subject matter and illustrations contained therein. Any reproduction, disclosure to third parties or utilization of its contents – in whole or in parts – is forbidden without prior written consent of ABB AG.

Copyright© 2010 ABB
All rights reserved