

Programmable Controller

CC-Link IE Field Network Analog-Digital Converter Module User's Manual

-NZ2GF2BN-60AD4
-NZ2EX2B-60AD4

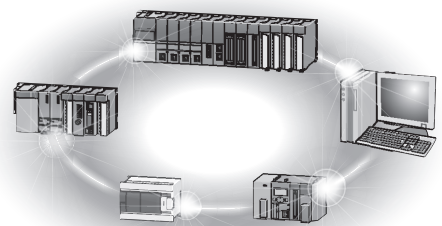

● SAFETY PRECAUTIONS ●

(Read these precautions before using this product.)

Before using this product, please read this manual and the relevant manuals carefully and pay full attention to safety to handle the product correctly.

The precautions given in this manual are concerned with this product only. For the safety precautions of the programmable controller system, refer to the user's manual for the CPU module used.

In this manual, the safety precautions are classified into two levels: "⚠ WARNING" and "⚠ CAUTION".



Indicates that incorrect handling may cause hazardous conditions, resulting in death or severe injury.



Indicates that incorrect handling may cause hazardous conditions, resulting in minor or moderate injury or property damage.

Under some circumstances, failure to observe the precautions given under "⚠ CAUTION" may lead to serious consequences.

Observe the precautions of both levels because they are important for personal and system safety.

Make sure that the end users read this manual and then keep the manual in a safe place for future reference.

[Design Precautions]

⚠ WARNING

- When a communication failure occurs in the network, data in the master module are held. Check Data link status (each station) (SW00B0 to SW00B7) and configure an interlock circuit in the program to ensure that the entire system will operate safely.
- Do not use any "use prohibited" signals as a remote input or output signal. These signals are reserved for system use. Do not write any data to the "use prohibited" areas in the remote register. Doing so may result in an accident due to an incorrect output or malfunction.

[Design Precautions]

⚠ CAUTION

- Do not install the control lines or communication cables together with the main circuit lines or power cables. Keep a distance of 100mm or more between them. Failure to do so may result in malfunction due to noise.

[Installation Precautions]

WARNING

- Shut off the external power supply (all phases) used in the system before mounting or removing a module. Failure to do so may result in electric shock or cause the module to fail or malfunction.

[Installation Precautions]

CAUTION

- Use the module in an environment that meets the general specifications in this manual. Failure to do so may result in electric shock, fire, malfunction, or damage to or deterioration of the product.
- Do not directly touch any conductive parts and electronic components of the module. Doing so can cause malfunction or failure of the module.
- After the first use of the product, do not connect/remove the extension module more than 50 times (IEC 61131-2 compliant). Exceeding the limit may cause malfunction.
- To connect an extension module to a main module, engage the respective connectors and securely lock the module joint levers. Incorrect connection may cause malfunction, failure, or drop of the module.
- Securely connect the cable connectors. Poor contact may cause malfunction.

[Wiring Precautions]

WARNING

- Shut off the external power supply (all phases) used in the system before wiring. Failure to do so may result in electric shock or cause the module to fail or malfunction.

[Wiring Precautions]

CAUTION

- Individually ground the FG terminal of the programmable controller with a ground resistance of 100 ohms or less. Failure to do so may result in electric shock or malfunction.
- Tighten any unused terminal screws within the specified torque range. Undertightening can cause a short circuit due to contact with a solderless terminal.
- Use applicable solderless terminals and tighten them within the specified torque range. If any spade solderless terminal is used, it may be disconnected when a terminal block screw comes loose, resulting in failure.
- Check the rated voltage and terminal layout before wiring to the module, and connect the cables correctly. Connecting a power supply with a different voltage rating or incorrect wiring may cause a fire or failure.
- Tighten the terminal block screws within the specified torque range. Undertightening can cause short circuit, fire, or malfunction. Overtightening can damage the screw and/or module, resulting in drop, short circuit, fire, or malfunction.
- Prevent foreign matter such as dust or wire chips from entering the module. Such foreign matter can cause a fire, failure, or malfunction.
- Place the cables in a duct or clamp them. If not, dangling cable may swing or inadvertently be pulled, resulting in damage to the module or cables or malfunction due to poor contact.
- Do not install the control lines or communication cables together with the main circuit lines or power cables. Keep a distance of 100mm or more between them. Failure to do so may result in malfunction due to noise.
- When disconnecting the cable from the module, do not pull the cable by the cable part. For the cable with connector, hold the connector part of the cable. For the cable connected to the terminal block, loosen the terminal screw. Pulling the cable connected to the module may result in malfunction or damage to the module or cable.
- When an overcurrent caused by an error of an external device or a failure of the programmable controller flows for a long time, it may cause smoke and fire. To prevent this, configure an external safety circuit, such as a fuse.
- Mitsubishi Electric programmable controllers must be installed in control panels. Wiring and replacement of a module must be performed by qualified maintenance personnel with knowledge of protection against electric shock. For wiring methods, refer to "INSTALLATION AND WIRING" in this manual.

[Startup and Maintenance Precautions]

WARNING

- Do not touch any terminal while power is on. Doing so will cause electric shock or malfunction.
- Shut off the external power supply (all phases) used in the system before cleaning the module or retightening the terminal block screws or connector screws. Failure to do so may cause the module to fail or malfunction.

[Startup and Maintenance Precautions]

CAUTION

- Do not disassemble or modify the module. Doing so may cause failure, malfunction, injury, or a fire.
- Do not drop or apply strong shock to the module. Doing so may damage the module.
- Shut off the external power supply (all phases) used in the system before mounting or removing a module. Failure to do so may cause the module to fail or malfunction.
- After the first use of the product, do not connect/remove the terminal block more than 50 times (IEC 61131-2 compliant). Exceeding the limit may cause malfunction.
- Before handling the module or connection cables, touch a conducting object such as a grounded metal to discharge the static electricity from the human body. Failure to do so may cause the module to fail or malfunction.
- Startup and maintenance of a control panel must be performed by qualified maintenance personnel with knowledge of protection against electric shock. Lock the control panel so that only qualified maintenance personnel can operate it.

[Disposal Precautions]

CAUTION

- When disposing of this product, treat it as industrial waste.

● CONDITIONS OF USE FOR THE PRODUCT ●

1) Mitsubishi programmable controller ("the PRODUCT") shall be used in conditions;

i) where any problem, fault or failure occurring in the PRODUCT, if any, shall not lead to any major or serious accident; and

ii) where the backup and fail-safe function are systematically or automatically provided outside of the PRODUCT for the case of any problem, fault or failure occurring in the PRODUCT.

2) The PRODUCT has been designed and manufactured for the purpose of being used in general industries.

MITSUBISHI SHALL HAVE NO RESPONSIBILITY OR LIABILITY (INCLUDING, BUT NOT LIMITED TO ANY AND ALL RESPONSIBILITY OR LIABILITY BASED ON CONTRACT, WARRANTY, TORT, PRODUCT LIABILITY) FOR ANY INJURY OR DEATH TO PERSONS OR LOSS OR DAMAGE TO PROPERTY CAUSED BY the PRODUCT THAT ARE OPERATED OR USED IN APPLICATION NOT INTENDED OR EXCLUDED BY INSTRUCTIONS, PRECAUTIONS, OR WARNING CONTAINED IN MITSUBISHI'S USER, INSTRUCTION AND/OR SAFETY MANUALS, TECHNICAL BULLETINS AND GUIDELINES FOR the PRODUCT.

("Prohibited Application")

Prohibited Applications include, but not limited to, the use of the PRODUCT in;

- Nuclear Power Plants and any other power plants operated by Power companies, and/or any other cases in which the public could be affected if any problem or fault occurs in the PRODUCT.
- Railway companies or Public service purposes, and/or any other cases in which establishment of a special quality assurance system is required by the Purchaser or End User.
- Aircraft or Aerospace, Medical applications, Train equipment, transport equipment such as Elevator and Escalator, Incineration and Fuel devices, Vehicles, Manned transportation, Equipment for Recreation and Amusement, and Safety devices, handling of Nuclear or Hazardous Materials or Chemicals, Mining and Drilling, and/or other applications where there is a significant risk of injury to the public or property.

Notwithstanding the above, restrictions Mitsubishi may in its sole discretion, authorize use of the PRODUCT in one or more of the Prohibited Applications, provided that the usage of the PRODUCT is limited only for the specific applications agreed to by Mitsubishi and provided further that no special quality assurance or fail-safe, redundant or other safety features which exceed the general specifications of the PRODUCTS are required. For details, please contact the Mitsubishi representative in your region.

INTRODUCTION

Thank you for purchasing the CC-Link IE Field Network analog-digital converter module (hereafter abbreviated as A/D converter module).

This manual describes the operating procedure, system configuration, parameter settings, functions, and troubleshooting of the A/D converter module.

Before using this product, please read this manual and the relevant manuals carefully and develop familiarity with the functions and performance of the A/D converter module to handle the product correctly.

When applying the program examples introduced in this manual to an actual system, ensure the applicability and confirm that it will not cause system control problems.

■ Relevant modules: NZ2GF2BN-60AD4, NZ2EX2B-60AD4

Remark

Unless otherwise specified, this manual describes the program examples in which the remote I/O signals and remote registers are assigned for an A/D converter module as follows.

- Remote input signal: RX0 to RX1F (main A/D converter module), RX20 to RX2F (extension A/D converter module)
- Remote output signal: RY0 to RY1F (main A/D converter module), RY20 to RY2F (extension A/D converter module)
- Remote register (RWr): RWr0 to RWrF (main A/D converter module), RWr10 to RWr1F (extension A/D converter module)
- Remote register (RWw): RWw0 to RWwF (main A/D converter module), RWw10 to RWw1F (extension A/D converter module)

For the assignment of remote I/O signals and remote registers, refer to the following.

 User's manual for the master/local module used

RELEVANT MANUALS

(1) CC-Link IE Field Network (relevant) manuals

When using the CC-Link IE Field Network for the first time, refer to CC-Link IE Field Network Master/Local Module User's Manual or Simple Motion Module User's Manual first. The following shows the structure of the CC-Link IE Field Network manuals.

Manual name <manual number (model code)>	Description
MELSEC-Q CC-Link IE Field Network Master/Local Module User's Manual [SH-080917ENG, 13JZ47]	Overview of the CC-Link IE Field Network, and specifications, procedures before operation, system configuration, installation, wiring, settings, functions, programming, and troubleshooting of the QJ71GF11-T2
MELSEC-L CC-Link IE Field Network Master/Local Module User's Manual [SH-080972ENG, 13JZ54]	Overview of the CC-Link IE Field Network, and specifications, procedures before operation, system configuration, installation, wiring, settings, functions, programming, and troubleshooting of the LJ71GF11-T2
MELSEC iQ-R Ethernet/CC-Link IE User's Manual (Startup) [SH-081256ENG, 13JX09]	Specifications, procedures before operation, system configuration, wiring, and communication examples of Ethernet, CC-Link IE Controller Network, and CC-Link IE Field Network
MELSEC iQ-R CC-Link IE Field Network User's Manual (Application) [SH-081259ENG, 13JX18]	Functions, parameter settings, programming, troubleshooting, I/O signals, and buffer memory of CC-Link IE Field Network
MELSEC iQ-R Inter-Module Synchronization Function Reference Manual [SH-081401ENG]	Inter-module synchronization function, which controls multiple modules synchronously
MELSEC-Q QD77GF Simple Motion Module User's Manual (Network) [IB-0300203, 1XB957]	Functions, programming, and troubleshooting for CC-Link IE Field Network of the QD77GF16
MELSEC-Q QD77GF Simple Motion Module User's Manual (Positioning Control) [IB-0300202, 1XB956]	Specifications of the QD77GF16 and information on how to establish a system, maintenance and inspection, and troubleshooting. Also included are functions, programming and buffer memory for the positioning control of the QD77GF16.
CC-Link IE Field Network Remote I/O Module User's Manual [SH-081114ENG, 13JZ82]	Specifications, procedures before operation, system configuration, installation, wiring, various settings, functions, programming, and troubleshooting of the CC-Link IE Field Network remote I/O module
CC-Link IE Field Network Digital-Analog Converter Module User's Manual [SH-081453ENG, 13JX27]	Specifications, procedures before operation, system configuration, installation, wiring, various settings, functions, programming, and troubleshooting of the CC-Link IE Field Network digital-analog converter module

(2) Operating manual

Manual name <manual number (model code)>	Description
GX Works2 Version 1 Operating Manual (Common) [SH-080779ENG, 13JU63]	System configuration, parameter settings, and online operations of GX Works2, which are common to Simple projects and Structured projects
GX Works3 Operating Manual [SH-081215ENG]	System configuration, parameter settings, and online operations of GX Works3

CONTENTS

SAFETY PRECAUTIONS	1
CONDITIONS OF USE FOR THE PRODUCT	5
INTRODUCTION	6
RELEVANT MANUALS	7
MANUAL PAGE ORGANIZATION	11
TERMS	12
PACKING LIST	14
<hr/>	
CHAPTER 1 A/D CONVERTER MODULE	15
<hr/>	
1.1 Application	15
1.2 Features	16
<hr/>	
CHAPTER 2 PART NAMES	20
<hr/>	
2.1 Main A/D Converter Module	20
2.2 Extension A/D Converter Module	23
<hr/>	
CHAPTER 3 SPECIFICATIONS	24
<hr/>	
3.1 General Specifications	24
3.2 Performance Specifications	25
3.2.1 Main A/D converter module	25
3.2.2 Extension A/D converter module	27
3.3 How to Calculate Current Consumption	29
3.4 Function List	30
3.5 List of Remote I/O Signals	32
3.5.1 Main A/D converter module	33
3.5.2 Extension A/D converter module	34
3.6 List of Remote Registers	35
3.6.1 Main A/D converter module	36
3.6.2 Extension A/D converter module	37
3.7 List of Remote Buffer Memory Areas	38
3.7.1 Main A/D converter module	39
3.7.2 Extension A/D converter module	44
<hr/>	
CHAPTER 4 PROCEDURES BEFORE OPERATION	46
<hr/>	
CHAPTER 5 SYSTEM CONFIGURATION	48
<hr/>	
5.1 System Configuration with A/D Converter Module	48
5.2 Applicable Systems	49
<hr/>	
CHAPTER 6 INSTALLATION AND WIRING	51
<hr/>	
6.1 Station Number Setting	51
6.2 Installation Environment and Installation Position	52
6.2.1 Installation environment	52
6.2.2 Installation position	52

6.2.3	Installation direction	53
6.3	Installation	54
6.3.1	How to connect an extension module	54
6.3.2	How to mount modules on a DIN rail	56
6.4	Wiring to Terminal Block for Module Power Supply and FG	59
6.5	Wiring of Ethernet Cable	61
6.6	Wiring of Terminal Block and External Devices	64

CHAPTER 7 VARIOUS SETTINGS	70
-----------------------------------	-----------

7.1	Parameter Settings	70
7.2	How to Change the Parameters	77
7.2.1	Changing the network configuration	77
7.2.2	Changing the parameters without changing the network configuration	81
7.3	Offset/Gain Setting	84

CHAPTER 8 FUNCTIONS	86
----------------------------	-----------

8.1	Mode Shift at Power-On	86
8.2	Drive Mode Switch	87
8.3	Each Function in the Sequence	89
8.4	A/D Conversion Enable/Disable Function	90
8.5	Conversion Speed Switch Function	90
8.5.1	Conversion speed and sampling period	91
8.6	A/D Conversion Method	96
8.7	Range Switching Function	100
8.8	Maximum Value/Minimum Value Hold Function	101
8.9	Input Signal Error Detection Function	102
8.10	Alert Output Function (Process Alarm)	106
8.11	Scaling Function	109
8.12	Shift Function	114
8.13	Digital Clipping Function	118
8.14	Difference Conversion Function	123
8.15	Trigger Conversion Function	128
8.16	CC-Link IE Field Network Synchronous Communication Function	136
8.17	Error Notification Function	143
8.18	Functions with an Extension Module Connected	146
8.18.1	Functions with an extension I/O module connected	146
8.18.2	Functions with the extension A/D converter module connected	151
8.18.3	Functions with the extension D/A converter module connected	152
8.19	CC-Link IE Field Network Diagnostic Function	153

CHAPTER 9 PROGRAMMING	156
------------------------------	------------

9.1	Precautions for Programming	156
9.2	Programming Procedure	157
9.3	Program Example	157

CHAPTER 10 MAINTENANCE AND INSPECTION	167
---------------------------------------	-----

CHAPTER 11 TROUBLESHOOTING	169
----------------------------	-----

11.1 How to Check Error Codes and Alarm Codes	169
11.2 Error Code List	173
11.2.1 Main A/D converter module	174
11.2.2 Extension A/D converter module	179
11.3 Alarm Code List	181
11.3.1 Main A/D converter module	181
11.3.2 Extension A/D converter module	181
11.4 Checking the LEDs	182
11.4.1 Main A/D converter module	182
11.4.2 Extension A/D converter module	185
11.5 Unit Test	186
11.6 Troubleshooting by Symptom	187
11.6.1 Main A/D converter module	187
11.6.2 Extension A/D converter module	189

APPENDICES	190
------------	-----

Appendix 1 Details of Remote I/O Signals	190
Appendix 1.1 Remote input signals	190
Appendix 1.2 Remote output signals	199
Appendix 2 Details of Remote Registers	202
Appendix 3 Details of Remote Buffer Memory	206
Appendix 4 I/O Conversion Characteristics of A/D Conversion	230
Appendix 5 Accuracy of A/D Conversion	233
Appendix 6 Processing Time of CC-Link IE Field Network	234
Appendix 7 EMC and Low Voltage Directives	235
Appendix 7.1 Measures to comply with the EMC Directive	235
Appendix 7.2 Requirements to compliance with the Low Voltage Directive	241
Appendix 8 How to Check Serial Number and Function Version	242
Appendix 9 Comparison with NZ2GF2B-60AD4	244
Appendix 9.1 Comparison of performance specifications	244
Appendix 9.2 Functional comparison	244
Appendix 9.3 About replacement from NZ2GF2B-60AD4 to NZ2GF2BN-60AD4	245
Appendix 10 External Dimensions	246
Appendix 10.1 Main A/D converter module	246
Appendix 10.2 Extension A/D converter module	246

INDEX	247
-------	-----

REVISIONS	250
WARRANTY	251
TRADEMARKS	252

MANUAL PAGE ORGANIZATION

In this manual, pages are organized and the symbols are used as shown below.

The following illustration is for explanation purpose only, and should not be referred to as an actual documentation.

Annotations for the manual page screenshot:

- ""** is used for window names and items.
- 1.** shows operating procedures.
- shows mouse operations.*1
- []** is used for items in the menu bar and the project window.
- Ex.** shows setting or operating examples.
- shows reference manuals.
- shows reference pages.
- Point** shows notes that require attention.
- Remark** shows useful information.

Manual page content highlights:

- CHAPTER 7 VARIOUS SETTINGS
- 7.1.1 Setting method
- (1) Setting parameters
- (a) Operating procedure
 1. Open the "PLC Parameter" dialog box.
Project window ⇨ [Parameter] ⇨ [PLC parameter]
 2. Select the "IO Assignment" tab.
- Table:

Item	Description	Reference
Type	Select the type of the connected module.	Page 74, Section 7.1.2
Model Name	Select the model name of the connected module.	Page 74, Section 7.1.3
Points	Set the number of points assigned to each slot.	Page 74, Section 7.1.4
Start XY	Specify a start I/O number for each slot.	Page 74, Section 7.1.5
Switch setting	Configure the switch setting of the built-in I/O or intelligent function module.	Page 74, Section 7.1.6
Default setting	Set the following: • Error Time Output Mode • PLC Operation Mode at HW Error • I/O Response Time	Page 75, Section 7.1.7
- Setting "Start XY" enables modification on the start I/O numbers assigned to connected modules.
 Ex. When "1000" is specified in "Start XY" to the slot where a 16-point module is connected, the assignment range of an input module is changed to X1000 to X100F.
- For details, refer to the following:
 Ex. MELSEC-L CPU Module User's Manual (Function Explanation, Program Fundamentals)
- Point**
 Set the type of the connected module in "Type". Setting a different type results in "SP.LIMIT LAY ERR."
 Ex. In the intelligent function module, the I/O points must also be the same in addition to the I/O assignment setting.
 Ex. Page 30, Section 4.2.2)
- Remark**
 When an intelligent module is connected, I/O assignment can be omitted by selecting connected modules from "Intelligent Function Module" in the Project window.

*1 The mouse operation example is provided below.





Annotations for the software interface screenshot:

- Menu bar**
 Ex. [Online] ⇨ [Write to PLC...]
 Select [Online] on the menu bar, and then select [Write to PLC...].
- A window selected in the view selection area is displayed.**
 Ex. Project window ⇨ [Parameter] ⇨ [PLC Parameter]
 Select [Project] from the view selection area to open the Project window. In the Project window, expand [Parameter] and select [PLC Parameter].
- View selection area**

TERMS

Unless otherwise specified, this manual uses the following terms.

Term	Description
A/D converter module	A generic term for the main A/D converter module and extension A/D converter module
Buffer memory	A memory in an intelligent function module, where data (such as setting values and monitoring values) exchanged with a CPU module are stored
CC-Link IE Field Network	A high-speed and large-capacity open field network that is based on Ethernet (1000BASE-T)
Cyclic transmission	A function by which data are periodically exchanged among stations on the same network using link devices (RX, RY, RWw, and RWr)
Data link	A generic term for cyclic transmission and transient transmission
Dedicated instruction	An instruction that simplifies programming for using functions of intelligent function modules
Disconnection	A process of stopping data link if a data link error occurs
Extension A/D converter module	The abbreviation for the NZ2EX2B-60AD4 CC-Link IE Field Network extension analog-digital converter module
Extension analog module	A generic term for the extension A/D converter module and extension D/A converter module
Extension D/A converter module	The abbreviation for the NZ2EX2BN-60DA4 CC-Link IE Field Network extension digital-analog converter module
Extension I/O module	A generic term for the extension input module and extension output module
Extension input module	A generic term for extension modules where digital signals can be input
Extension module	A remote module with no CC-Link IE Field Network communication function. This module cannot be used as a single module. However, connecting the module to the main module will increase the number of I/O points per station.
Extension output module	A generic term for extension modules where digital signals can be output
GX Works2	The product name of the software package for the MELSEC programmable controllers
GX Works3	
I/O module	Another term for the CC-Link IE Field Network remote I/O module
Intelligent device station	A station that exchanges I/O signals (bit data) and I/O data (word data) with another station by cyclic transmission. This station responds to a transient transmission request from another station and also issues a transient transmission request to another station.
Link device	A device (RX, RY, RWr, or RWw) in a module on CC-Link IE Field Network
Link special register (SW)	Word data that indicates the operating status and data link status of a module on CC-Link IE Field Network
Link special relay (SB)	Bit data that indicates the operating status and data link status of a module on CC-Link IE Field Network
Local station	A station that performs cyclic transmission and transient transmission with the master station and other local stations. The station is controlled by programs in the CPU module or other equivalent modules on the station.
Main A/D converter module	The abbreviation for the NZ2GF2BN-60AD4 CC-Link IE Field Network main analog-digital converter module
Main analog module	A generic term for the main A/D converter module and main D/A converter module
Main D/A converter module	The abbreviation for the NZ2GF2BN-60DA4 CC-Link IE Field Network main digital-analog converter module
Main module	A module with the CC-Link IE Field Network communication function, which can be used as a single remote module.
Master station	A station that controls the entire network. This station can perform cyclic transmission and transient transmission with all stations. Only one master station can be used in a network.
Master/local module	A generic term for the CC-Link IE Field Network master/local module
Network module	A generic term for the following modules: <ul style="list-style-type: none"> • CC-Link IE Field Network module • CC-Link IE Controller Network module • Ethernet interface module • MELSECNET/H module • MELSECNET/10 module
Relay station	A station that includes two or more network modules. Data are passed through this station to stations on other networks
REMFR	The abbreviation for ZP.REMFR.
Remote buffer memory	Buffer memory in a remote device station
Remote device station	A station that exchanges I/O signals (bit data) and I/O data (word data) with another station by cyclic transmission. This station responds to a transient transmission request from another station.
Remote I/O station	A station that exchanges I/O signals (bit data) with the master station by cyclic transmission

Term	Description
Remote input (RX)	Bit data input from a slave station to the master station (For some areas in a local station, data are input in the opposite direction.)  User's manual for the master/local module used
Remote output (RY)	Bit data output from the master station to a slave station (For some areas in a local station, data are output in the opposite direction.)  User's manual for the master/local module used
Remote register (RWr)	Word data input from a slave station to the master station (For some areas in a local station, data are input in the opposite direction.)  User's manual for the master/local module used
Remote register (RWw)	Word data output from the master station to a slave station (For some areas in a local station, data are output in the opposite direction.)  User's manual for the master/local module used
REMTO	The abbreviation for ZP.REMTO.
Reserved station	A station reserved for future use. This station is not actually connected, but counted as a connected station
Return	A process of restarting data link when a station recovers from an error
Simple motion module	The abbreviation for the QD77GF CC-Link IE Field Network simple motion module
Slave station	A generic term for stations other than a master station: local station, remote I/O station, remote device station, and intelligent device station
Transient transmission	A function of communication with another station, which is used when requested by a dedicated instruction or GX Works2

PACKING LIST

The following items are included in the package of this product. Before use, check that all the items are included.

A/D converter module

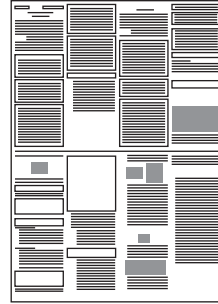
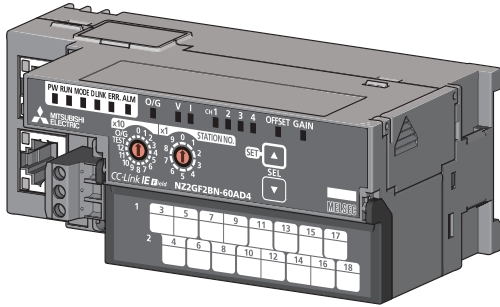

Module (The figure above shows the main A/D converter module.)

Before Using the Product

CHAPTER 1 A/D CONVERTER MODULE

This chapter describes the application and the features of the A/D converter module.

1.1 Application

The A/D converter module converts analog values that are input from external devices to digital operation values.

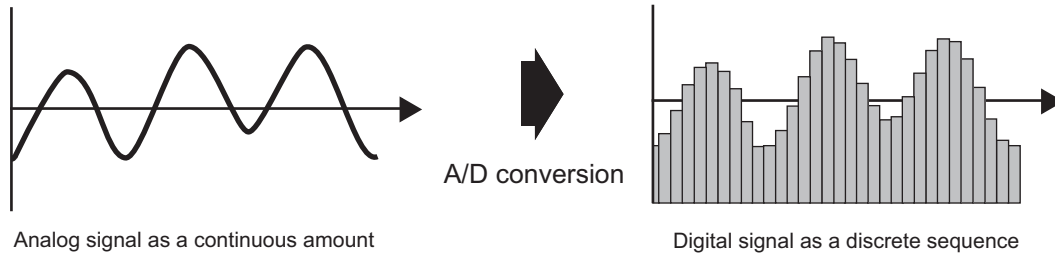

The converted digital operation value can be checked in the master station.

Using the A/D converter module allows the flow or temperature measured by the A/D converter module to be checked through the master station.

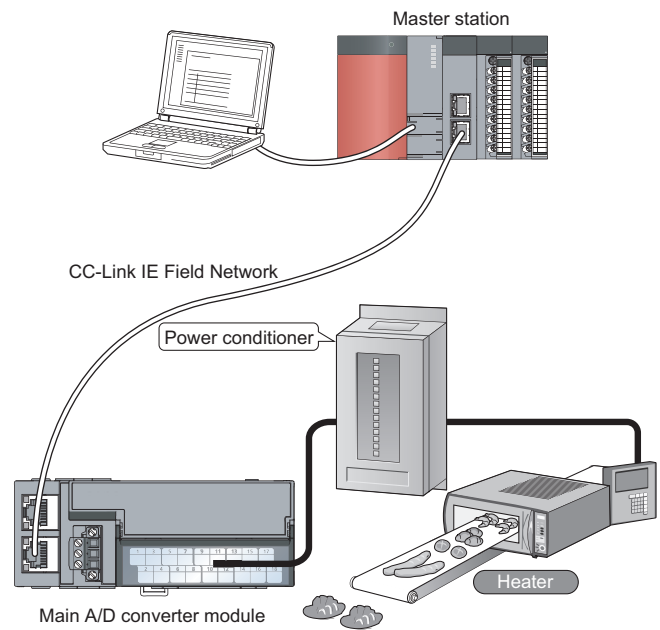
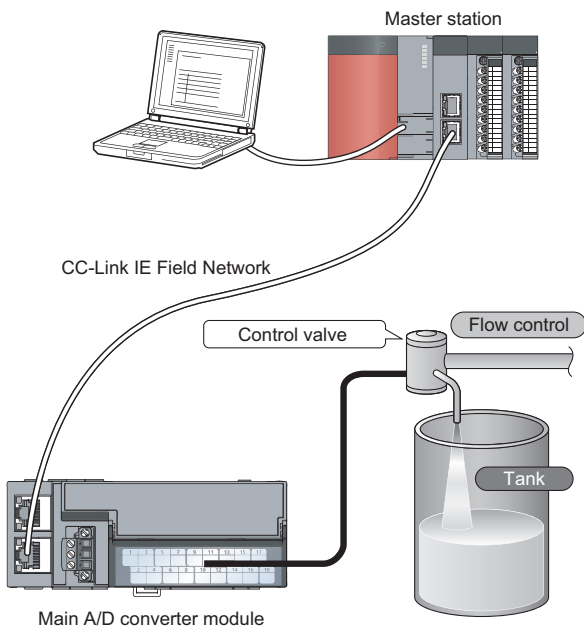

1.1 Application

1.2 Features

(1) Flexible system configuration

The employed connection block type provides the combined use of a main module and an extension module. A flexible configuration can be achieved because various extension modules can be connected. In addition, the main module always monitors the connection status of the extension module, leading to an early detection of connection failure.

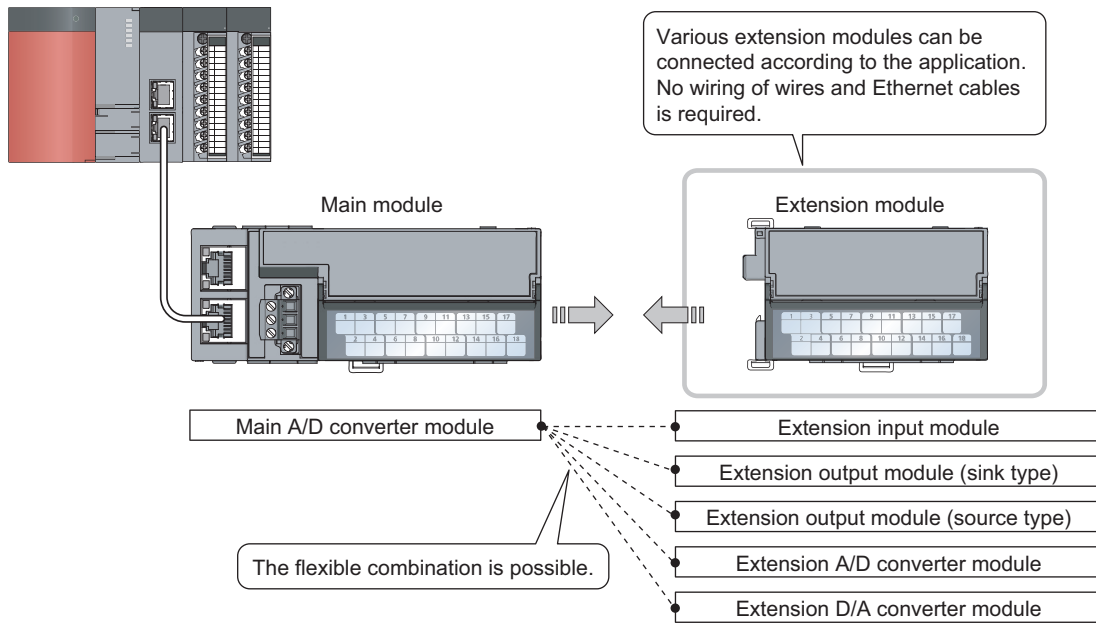

(2) Easy setting of station numbers

Station numbers are set with the rotary switch on the front of the module, where setting and checking the station numbers are easy.

(3) Selectable conversion speed

A/D conversion at $100\mu\text{s}/\text{channel}$ meets the need of a high-speed conversion.

Under the environment in which noise is likely to occur, switching the conversion speed to $400\mu\text{s}/\text{channel}$ or $1\text{ms}/\text{channel}$ minimizes the effect of noise on the digital operation value, the stability of which is improved.

(4) A/D conversion at any desired timing

A/D conversion is performed once immediately after the input of a trigger conversion request to obtain the digital operation value.

The combination with the external signal assignment function allows direct input of a trigger conversion request from the extension input module, with the following advantages:

- Being free from the effect of the sequence scan and link scan, digital operation values can be constantly obtained at a given timing, which leads to the improvement of the reliability.
- Digital operation values can be obtained without any program, which leads to a reduction in the cost of creating a program.

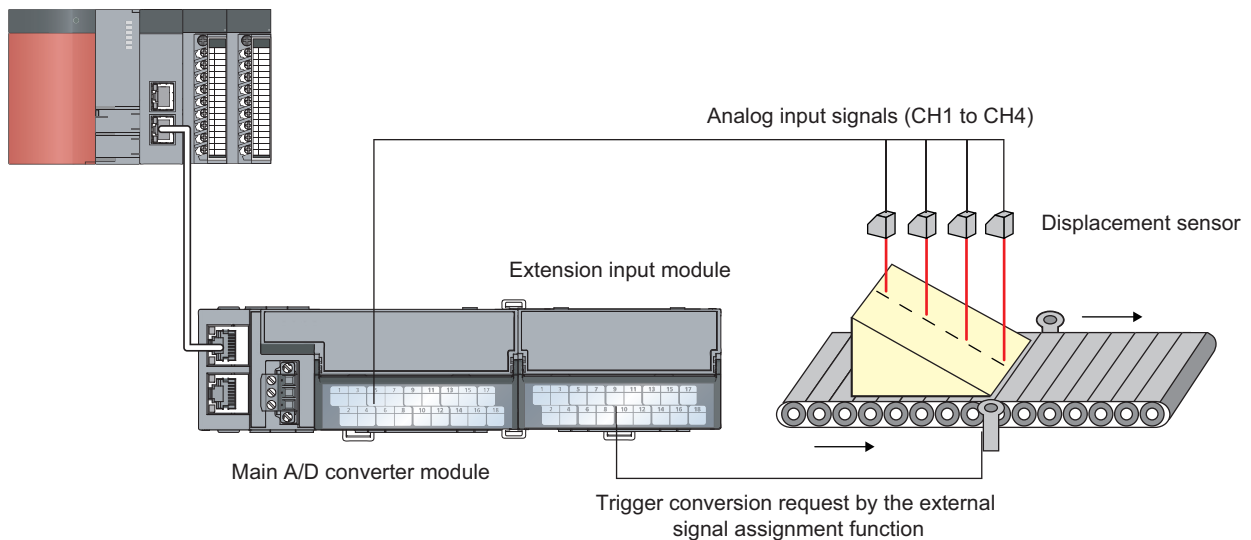

(5) Change to any scale

A/D conversion values can be converted to be within any scale, the range of which is determined arbitrarily. According to the device that handles digital operation values, the scale can be changed without any program, resulting in cost reduction.

(6) Detection of the disconnection

An input range of 1 to 5V, or 4 to 20mA allows the detection of the disconnection of analog input, facilitating the diagnosis of the cause at the time of a trouble.

In combination with the external signal assignment function, the extension output module allows a signal (input signal error detection signal) to be output to the outside without any program upon detection of the disconnection. At this time, there is no influence of the sequence scan and link scan.

(7) Input and output without an influence of the sequence scan and link scan

Using the external signal assignment function allows a trigger conversion request to be input from the extension input module. In the event of an error or an alert, an error status or an alert status can be output from the extension output module.

These input and output are not affected by the sequence scan and link scan.

Ex. To turn on the lamp when an error occurs.

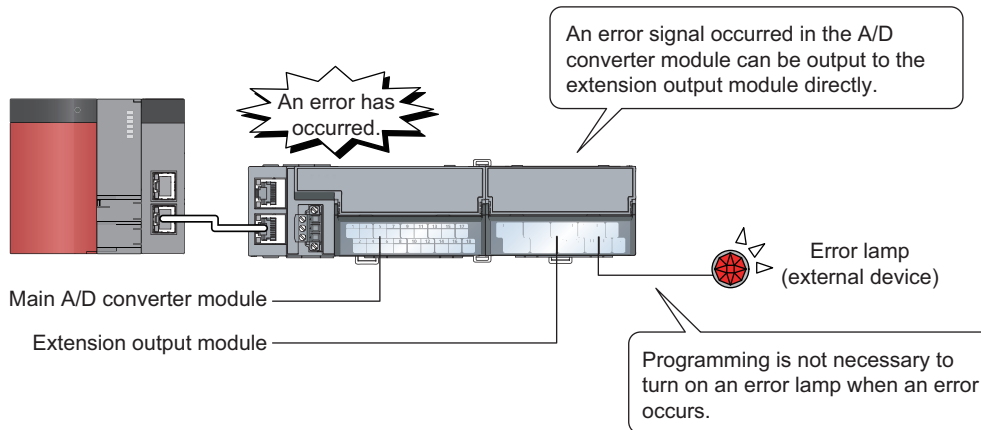

(8) Support for the CC-Link IE Field Network synchronous communication function

A/D conversion can be performed together with the synchronization period of the master station that supports the CC-Link IE Field Network synchronous communication function.

This enables the A/D converter module to operate at the same timing of other slave stations sharing the same network.

(9) Various installation methods

The module can be installed in six directions using a DIN rail.

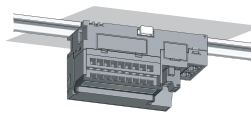

Downward installation

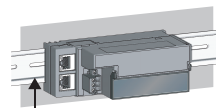

DIN rail

Horizontal installation

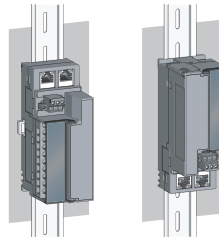

Vertical installation

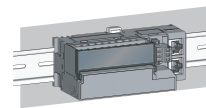

Horizontal installation
(upside down)

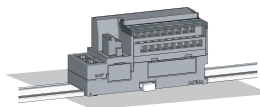

Upward installation

(10) Easy module replacement

The terminal block for module power supply and FG, and the terminal block for analog input signals have a two-piece structure, where the module can be replaced with the wire connected. In addition, the terminal block for analog input signals has a lift-up structure, where the terminal block lifts only by loosening the terminal block mounting screw, enabling it to be removed easily.

(11) Check on the error history

The history of the last 15 errors and occurrence time is stored in the main A/D converter module. Checking the error information of the past helps to identify the cause at the time of a trouble.

(12) Easy settings by CC IE Field configuration of the engineering tool

The CC IE Field configuration of the engineering tool makes it possible to set parameters on its window, thereby reducing the programs. In addition, the setting status and the operating status of modules can be checked easily.

CHAPTER 2 PART NAMES

2.1 Main A/D Converter Module

This section describes part names of the main A/D converter module.

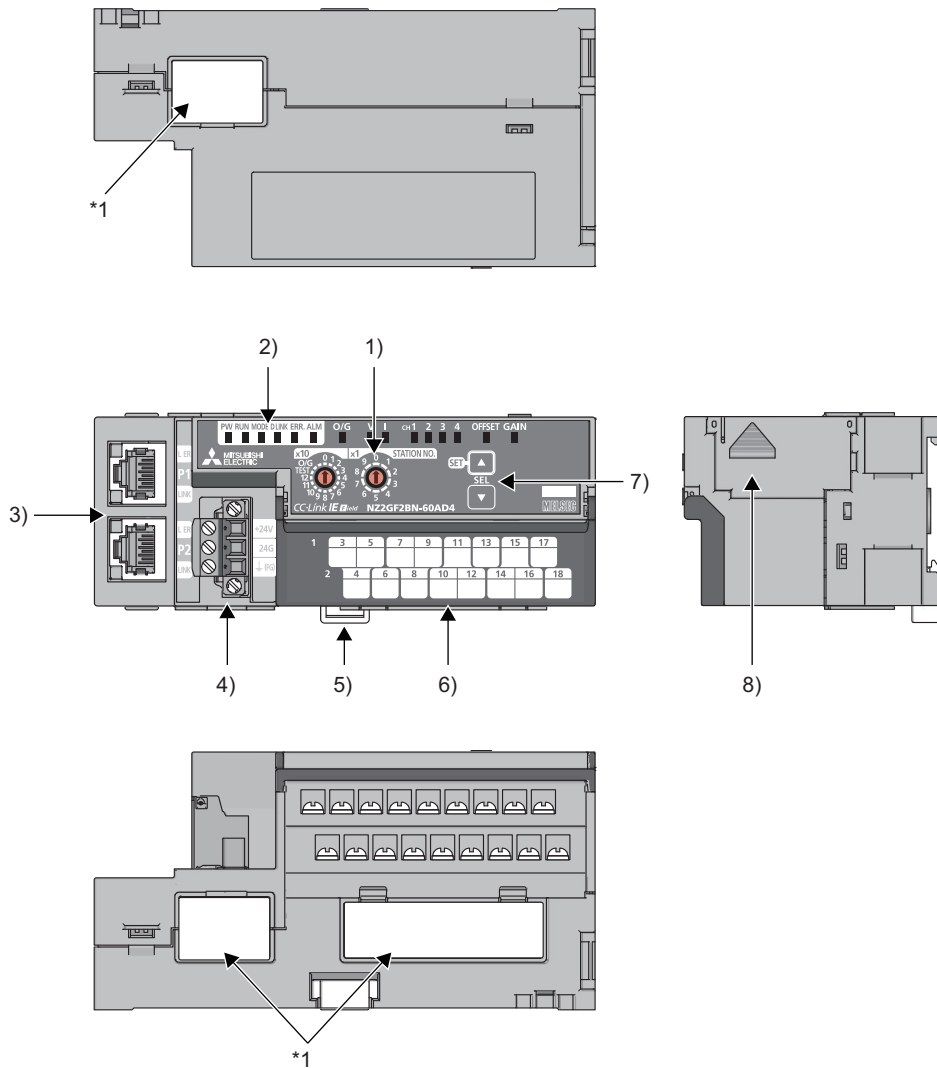

*1 Do not remove this seal because it is used for our maintenance purposes.

No.	Name	Application
1)	Station number setting switch	<p>A rotary switch for the following setting and test.</p> <ul style="list-style-type: none"> • Station Number Setting (☞ Page 51, Section 6.1) • Offset/Gain Setting (☞ Page 84, Section 7.3) • Unit Test (☞ Page 186, Section 11.5) <p>When operating the station number setting switch, use a slotted screwdriver with 3.5mm or less width of the tip.</p>

No.	Name	Application	
2)	PW LED (green)	Indicates the power supply status of the main A/D converter module. • On: Power-on • Off: Power-off	
	RUN LED (green)	Indicates the operating status of the main A/D converter module. • On: Operating normally; Writing data to the non-volatile memory (while in offset/gain setting mode) • Off: Major error occurred	
	MODE LED (green)	Indicates the mode of the main A/D converter module. • On: In online mode • Flashing: In unit test mode • Off: In offset/gain setting mode	
	D LINK LED (green)	Indicates the data link status of the main A/D converter module. • On: Data link in operation (cyclic transmission in progress) • Flashing: Data link in operation (cyclic transmission stopped) • Off: Data link not performed (disconnected)	
	ERR. LED (red)	Indicates the error status of the main A/D converter module and the extension module. • On: Moderate error or major error occurred • Flashing: Warning occurred • Off: In normal operation	
	ALM LED (red)	Indicates the alert status of the main A/D converter module and the extension module. • On: Alert issued • Flashing: Input signal error detected • Off: In normal operation	
	O/G LED (green)	Indicates the module is in offset/gain setting mode. • On: In offset/gain setting mode • Off: In a mode other than offset/gain setting mode	
	V LED (green), I LED (green)	Indicates the user range of a set target selected in offset/gain setting mode.	
		Set target	V LED I LED
		User range setting 1 (-10 to 10V) User range setting 2 (-5 to 5V, -20 to 20mA)	On Off Off On
CH1 to CH4 LED (green)	Indicates the channel of a set target selected in offset/gain setting mode. • On: The channel corresponding to the number being on is the set target. • Off: The channel corresponding to the number being off is not the set target.		
OFFSET LED (green), GAIN LED (green)	Indicates whether the selected setting is offset or gain in the offset/gain setting mode.		
	Set target	OFFSET LED GAIN LED	
	Offset Gain	On Off Off On	
3)	P1	PORT1 connector for the connection to CC-Link IE Field Network (RJ45 connector) Connect an Ethernet cable. (☞ Page 61, Section 6.5) There are no restrictions on the connection order of the cables for the P1 connector and P2 connector.	
	L ER LED (red)	• On: Module received abnormal data, or module performing loopback • Off: Module received normal data, or module not performing loopback	
	LINK LED (green)	• On: Link-up • Off: Link-down	
	P2	PORT2 connector for the connection to CC-Link IE Field Network (RJ45 connector) Connect an Ethernet cable. (☞ Page 61, Section 6.5) There are no restrictions on the connection order of the cables for the P1 connector and P2 connector.	
	L ER LED (red) LINK LED (green)	(same as the LEDs of the P1 connector)	
4)	Terminal block for module power supply and FG	A terminal block for the connection of a module power supply (24VDC) and FG	
5)	DIN rail hook	A hook for mounting a module on a DIN rail	
6)	Terminal cover	Covers for preventing electric shock while the power is on	
	Terminal block for analog input signals	A two-piece screw terminal block for the connection to an external device	
7)	SET/SEL button	In offset/gain setting mode, select the set target by pressing ▲ button or ▼ button.	
8)	Extension connector cover	A cover to protect a connector of an extension module. Do not remove the cover if an extension module is not connected to the connector.	

(1) Module status and LED status

The following table shows how module status and LED status correspond each other.

Module status		Data link status	LED status						
			PW LED	RUN LED	MODE LED	D LINK LED	ERR. LED	ALM LED	O/G LED
Normal mode	Disconnecting	Disconnection	On	On	On	Off	Off	Off	Off
	Data link in operation	Data link in operation	On	On	On	On	Off	Off	Off
	Reserved station specification in progress	Cyclic stop	On	On	On	Flashing	Off	Off	Off
	Link stop	Cyclic stop	On	On	On	Flashing	Off	Off	Off
Offset/gain setting mode		—	On	Off	Off	Off	Off	*1	On
Unit test	In progress	—	On	On	Flashing	Off	Off	Off	Off
	Completed successfully	—	On	On	Off	Off	Off	Off	Off
	Completed with an error	—	On	On	Off	Off	On	Off	Off
Communication error		Cyclic stop	On	On	On	Flashing	Off	Off	Off
Error	Major error	—	On	Off	*2	*1	On*3	*1	Off
	Moderate error	—	On	On	*2	*1	On	*1	Off
Warning	Minor error	—	On	On	*2	*1	Flashing	*1	Off
Alarm	Alert issued	—	On	On	On	*1	*1	On	Off
	Input signal error occurred	—	On	On	On	*1	*1	Flashing	Off

*1 Either On, Flashing, or Off.

*2 Either On or Off.

*3 A failure of the module may not allow the LED to turn on.

2.2 Extension A/D Converter Module

This section describes part names of the extension A/D converter module.

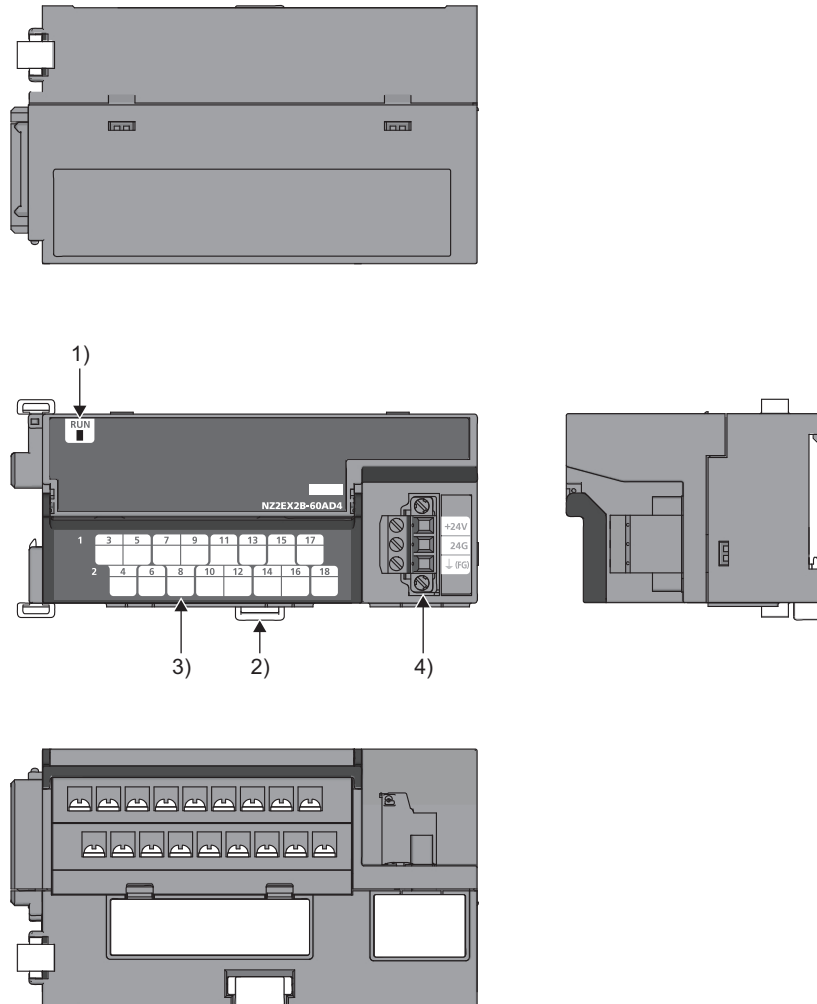

No.	Name	Application
1)	RUN LED (green)	Indicates the operating status of the extension A/D converter module. <ul style="list-style-type: none"> • On: In normal operation • Flashing: External power supply being off • Off: Major error occurred; main analog module being in offset/gain setting mode; or main analog module being in unit test mode
2)	DIN rail hook	A hook for mounting a module on a DIN rail
3)	Terminal cover	Covers for preventing electric shock while the power is on
	Terminal block for analog input signals	A two-piece terminal block for the connection to an external device
4)	Terminal block for external power supply and FG	A terminal block for the connection of an external power supply (24VDC) and FG

CHAPTER 3 SPECIFICATIONS

This chapter describes the specifications of the A/D converter module.

3.1 General Specifications

Item	Specifications					
Operating ambient temperature	0 to 55°C					
Storage ambient temperature	-25 to 75°C					
Operating ambient humidity	5 to 95%RH, non-condensing					
Storage ambient humidity						
Vibration resistance	Compliant with JIS B 3502 and IEC 61131-2	Under intermittent vibration	Frequency	Constant acceleration	Half amplitude	Number of sweeps
			5 to 8.4Hz	—	3.5mm	10 times each in X, Y, and Z directions
		Under continuous vibration	8.4 to 150Hz	9.8m/s ²	—	
			5 to 8.4Hz	—	1.75mm	—
8.4 to 150Hz	4.9m/s ²	—				
Shock resistance	Compliant with JIS B 3502 and IEC 61131-2 (147m/s ² , 3 times each in X, Y, and Z directions)					
Operating atmosphere	No corrosive gases					
Operating altitude*1	0 to 2000m					
Installation location	Inside a control panel*2					
Oversvoltage category*3	II or less					
Pollution degree*4	2 or less					
Equipment class	Class I					

*1 Do not use or store the A/D converter module under pressure higher than the atmospheric pressure at an altitude of 0 meters. Doing so may cause malfunction. When using the A/D converter module under pressure, please consult your local Mitsubishi representative.

*2 If the environment satisfies the operating ambient temperature, operating ambient humidity and other conditions, the module can be used even outside the control panel.

*3 This indicates the assumption that the equipment is connected to which type of power distribution system, from the public electrical power distribution network down to machinery within premises. Category II applies to equipment for which electrical power is supplied from fixed facilities. The surge voltage withstand level for the equipment with up to the rated voltage of 300V is 2500V.

*4 This index indicates the degree to which conductive material is generated in terms of the environment in which the equipment is used. In pollution degree 2, only non-conductive pollution occurs. A temporary conductivity caused by condensation must be expected occasionally.

Point

For compliance with the EMC Directive, refer to "EMC and Low Voltage Directives" in this manual. (Page 235, Appendix 7)

3.2 Performance Specifications

3.2.1 Main A/D converter module



Item		Description				
Station type		Remote device station				
Number of analog input points		4 points (4 channels)/module				
Analog input	Voltage	-10 to 10VDC (input resistance 1M Ω)				
	Current	0 to 20mADC (input resistance 250 Ω)				
Digital output		16-bit signed binary (-16384 to 16383)				
I/O characteristics, maximum resolution ^{*1}		Input	Input range	Digital output value	Maximum resolution	
		Voltage	-10 to 10V	-16000 to 16000	0 to 16000	0.625mV
			User range setting 1 (-10 to 10V)			0.5mV
			User range setting 2 (-5 to 5V)			0.25mV
		Current	0 to 5V	0 to 16000	0 to 16000	0.3125mV
			1 to 5V			0.25mV
			0 to 20mA			1.25 μ A
		Current	4 to 20mA	-16000 to 16000	-16000 to 16000	1 μ A
			User range setting 2 (-20 to 20mA)			1 μ A
Conversion accuracy ^{*2}	Ambient temperature (25 \pm 5 $^{\circ}$ C)	\pm 0.1%				
	Ambient temperature (0 to 55 $^{\circ}$ C)	\pm 0.2%				
Conversion speed ^{*5}		100 μ s/channel 400 μ s/channel 1ms/channel				
Absolute maximum input		Voltage: \pm 15V, Current: \pm 30mA ^{*3}				
Isolation method		Between communication system terminal and all analog input terminals: Photocoupler isolation Between power supply system terminal and all analog input terminals: Transformer isolation Between input channels: Non-isolation				
Withstand voltage		Between all power supply and communication system terminals and all analog input terminals 500VAC for 1 minute				
Noise immunity		Noise voltage 500Vp-p, noise width 1 μ s, noise frequency 25 to 60Hz (noise simulator condition)				
External interface	Communication part	RJ45 connector				
	Module power supply part	Terminal block for module power supply and FG Tightening torque range for terminal screw (M2.5 screw): 0.5 to 0.6N·m				
	I/O part	18-point two-piece terminal block (M3 screw) Tightening torque range for terminal screw (M3 screw \times 5.2): 0.43 to 0.57N·m				
Applicable DIN rail		TH35-7.5Fe, TH35-7.5Al (compliant with IEC 60715)				
Applicable wire size	For power supply	Core: 0.5 to 1.5mm ² (20 to 16 AWG)				
	For I/O	Core: 0.3 to 2.0mm ² (22 to 14 AWG)				

Item	Description	
Applicable solderless terminal	Terminal block for module power supply and FG*4	TE 0.5-10 (NICHIFU Co., Ltd.) [Applicable wire size: 0.5mm ²] TE 0.75-10 (NICHIFU Co., Ltd.) [Applicable wire size: 0.75mm ²] TE 1.0-10 (NICHIFU Co., Ltd.) [Applicable wire size: 0.9 to 1.0mm ²] TE 1.5-10 (NICHIFU Co., Ltd.) [Applicable wire size: 1.25 to 1.5mm ²] AI 0.5-10WH (Phoenix Contact Co., Ltd.) [Applicable wire size: 0.5mm ²] AI 0.75-10GY (Phoenix Contact Co., Ltd.) [Applicable wire size: 0.75mm ²] AI 1-10RD (Phoenix Contact Co., Ltd.) [Applicable wire size: 1.0mm ²] AI 1.5-10BK (Phoenix Contact Co., Ltd.) [Applicable wire size: 1.5mm ²]
	Terminal block for analog input signals	RAV1.25-3 (compliant with JIS C 2805) [Applicable wire size: 0.3 to 1.25mm ²] V2-MS3 (JST Mfg. Co., Ltd) [Applicable wire size: 1.25 to 2.0mm ²] RAP2-3SL (Nippon Tanshi Co., Ltd.) [Applicable wire size: 1.25 to 2.0mm ²] TGV2-3N (NICHIFU Co., Ltd.) [Applicable wire size: 1.25 to 2.0mm ²]
Cyclic transmission	RX/Ry points	32 points + 16 points × Number of extension modules
	RWr/RWw points	16 points + Points of each extension module
Communication cable	An Ethernet cable that meets the 1000BASE-T standard: Category 5e or higher (double shielded, STP), straight cable	
Applicability of extension module	Connectable (Max. one module)	
External power supply	24VDC (20.4 to 28.8VDC) Inrush current: 36.5A, 1ms or lower Current consumption: 210mA	
Weight	0.30kg	

- *1 For details on the I/O conversion characteristics, refer to the following:
 - I/O Conversion Characteristics of A/D Conversion (☞ Page 230, Appendix 4)
- *2 Except for the conditions under noise influence.
- *3 This current value is an instantaneous value at which no breakdown occurs in the internal resistance of the module. The maximum input current value for constant application is 24mA.
- *4 Do not connect two or more cables to the terminal.
- *5 The sampling period varies depending on whether an extension analog module is connected or not. For details, refer to the following:
 - Conversion Speed and Sampling Period (☞ Page 91, Section 8.5.1)

3.2.2 Extension A/D converter module

Item		Description			
Number of analog input points		4 points (4 channels)/module			
Analog input	Voltage	-10 to 10VDC (input resistance 1M Ω)			
	Current	0 to 20mADC (input resistance 250 Ω)			
Digital output		16-bit signed binary (-16384 to 16383)			
I/O characteristics, maximum resolution*1		Input	Input range	Digital output value	Maximum resolution
		Voltage	-10 to 10V	-16000 to 16000	0.625mV
			0 to 5V	0 to 16000	0.3125mV
			1 to 5V		0.25mV
		Current	0 to 20mA	0 to 16000	1.25 μ A
			4 to 20mA		1 μ A
Conversion accuracy*2	Ambient temperature (25 \pm 5 $^{\circ}$ C)	\pm 0.1%			
	Ambient temperature (0 to 55 $^{\circ}$ C)	\pm 0.2%			
Conversion speed*5		100 μ s/channel 400 μ s/channel 1ms/channel			
Absolute maximum input		Voltage: \pm 15V, Current: \pm 30mA*3			
Isolation method		Between communication system terminal and all analog input terminals: Photocoupler isolation Between power supply system terminal and all analog input terminals: Transformer isolation Between input channels: Non-isolation			
Withstand voltage		Between all power supply and communication system terminals and all analog input terminals 500VDC for 1 minute			
Noise immunity		Noise voltage 500Vp-p, noise width 1 μ s, noise frequency 25 to 60Hz (noise simulator condition)			
External interface	External power supply part	Terminal block for external power supply and FG Tightening torque range for terminal screw (M2.5 screw): 0.5 to 0.6N-m			
	I/O part	18-point two-piece terminal block (M3 screw) Tightening torque range for terminal screw (M3 screw \times 5.2): 0.43 to 0.57N-m			
Applicable DIN rail		TH35-7.5Fe, TH35-7.5Al (compliant with IEC 60715)			
Applicable wire size	For power supply	Core: 0.5 to 1.5mm 2 (20 to 16 AWG)			
	For I/O	Core: 0.3 to 2.0mm 2 (22 to 14 AWG)			
Applicable solderless terminal	Terminal block for external power supply and FG*4	TE 0.5-10 (NICHIFU Co., Ltd.) [Applicable wire size: 0.5mm 2] TE 0.75-10 (NICHIFU Co., Ltd.) [Applicable wire size: 0.75mm 2] TE 1.0-10 (NICHIFU Co., Ltd.) [Applicable wire size: 0.9 to 1.0mm 2] TE 1.5-10 (NICHIFU Co., Ltd.) [Applicable wire size: 1.25 to 1.5mm 2] AI 0.5-10WH (Phoenix Contact Co., Ltd.) [Applicable wire size: 0.5mm 2] AI 0.75-10GY (Phoenix Contact Co., Ltd.) [Applicable wire size: 0.75mm 2] AI 1-10RD (Phoenix Contact Co., Ltd.) [Applicable wire size: 1.0mm 2] AI 1.5-10BK (Phoenix Contact Co., Ltd.) [Applicable wire size: 1.5mm 2]			
	Terminal block for analog input signals	RAV1.25-3 (compliant with JIS C 2805) [Applicable wire size: 0.3 to 1.25mm 2] V2-MS3 (JST Mfg. Co., Ltd) [Applicable wire size: 1.25 to 2.0mm 2] RAP2-3SL (Nippon Tanshi Co., Ltd.) [Applicable wire size: 1.25 to 2.0mm 2] TGV2-3N (NICHIFU Co., Ltd.) [Applicable wire size: 1.25 to 2.0mm 2]			
Cyclic transmission	RX/Ry points	16 points			
	RW r /RW w points	16 points			
Module power supply (supplied from a main module)	Voltage	24VDC (20.4 to 28.8VDC)			
	Current	90mA			
External power supply		24VDC (20.4 to 28.8VDC) Inrush current: 22.0A, 1ms or lower Current consumption: 45mA			
Weight		0.22kg			

- *1 For details on the I/O conversion characteristics, refer to the following:
 - I/O Conversion Characteristics of A/D Conversion ( Page 230, Appendix 4)
- *2 Except for the conditions under noise influence.
- *3 This current value is an instantaneous value at which no breakdown occurs in the internal resistance of the module. The maximum input current value for constant application is 24mA.
- *4 Do not connect two or more wires to the terminal.
- *5 The module operates at the conversion speed of a main analog module. For details, refer to the following:
 - Conversion Speed and Sampling Period ( Page 91, Section 8.5.1)

3.3 How to Calculate Current Consumption

The total current consumption of the modules is calculated by summing the module power supply current in the main A/D converter module and extension module.

For the value of the module power supply current, refer to the specifications of each module.

- Performance specifications of main A/D converter module (☞ Page 25, Section 3.2.1)
- Performance specifications of extension A/D converter module (☞ Page 27, Section 3.2.2)
- Performance specifications of extension I/O module (📖 CC-Link IE Field Network Remote I/O Module User's Manual)
- Performance specifications of extension D/A converter module (📖 CC-Link IE Field Network Digital-Analog Converter Module User's Manual)

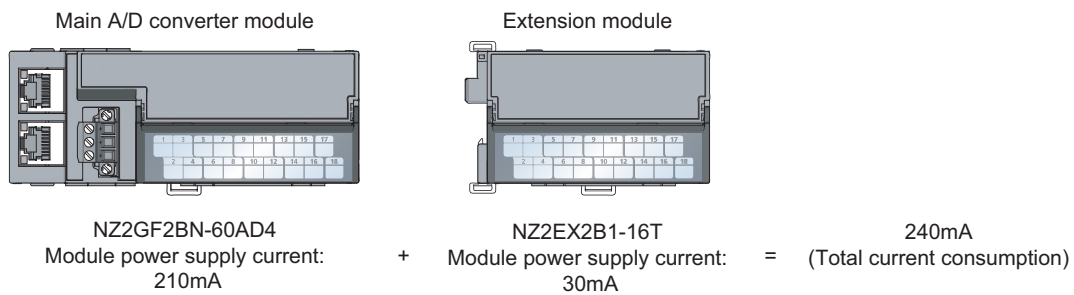

The value of the module power supply current in the extension module described in the specifications is the value of the module power supply current supplied from the main A/D converter module.



3.4 Function List

○: Available, ×: Not available

Item		Description	Available or not		Reference	
			Main ^{*1}	Extension ^{*1}		
A/D conversion enable/disable function		Allows A/D conversion to be enabled or disabled for each channel. Disabling the A/D conversion for unused channels reduces the conversion cycles.	○	○	Page 90, Section 8.4	
Conversion speed switch function		Allows the selection of the conversion speeds to be either 100μs, 400μs or 1ms.	○	○	Page 90, Section 8.5	
A/D conversion method	Sampling processing	Performs A/D conversion on analog input values sequentially, storing the digital operation values into the remote register.			Page 96, Section 8.6 (1)	
	Averaging processing	Time average			Page 96, Section 8.6 (2) (a)	
		Count average	Performs A/D conversion a set number of times and averages the total value excluding the maximum and the minimum values, storing the averaged value into the remote register. Time taken to store the average value by count average varies depending on the number of channels used (the number of channels where A/D conversion is enabled).	○	○	Page 97, Section 8.6 (2) (b)
		Moving average	Takes in digital operation values a set number of times at every sampling period and averages these values, storing the averaged value into the remote register. The target range for average processing moves at each sampling, thereby allowing the latest digital operation value to be obtained.			Page 98, Section 8.6 (2) (c)
Range switching function		Allows the input range to be selected for each channel from the following: <ul style="list-style-type: none"> Factory default range (4 to 20mA, 0 to 20mA, 1 to 5V, 0 to 5V, -10 to 10V) User range (user range setting 1, user range setting 2) 	○	○ ^{*2}	Page 100, Section 8.7	
Offset/gain setting function		Allows the correction of errors in digital output values.	○	×	Page 84, Section 7.3	
Maximum value/minimum value hold function		For each channel, stores the maximum and minimum values of digital operation values into the remote buffer memory.	○	○	Page 101, Section 8.8	
Input signal error detection function		Detects a disconnection of analog input signals.	○	○	Page 102, Section 8.9	
Alert output function (process alarm)		Outputs an alert when a digital operation value falls within the alert output range set in advance.	○	○	Page 106, Section 8.10	
Scaling function		Performs scale conversion on a digital operation value within the range of the scaling upper limit value and the scaling lower limit value, both of which are set at desired values.	○	○	Page 109, Section 8.11	
Shift function		Adds the conversion value shift amount specified to a digital operation value and stores it into the remote register. This function facilitates fine adjustment at the system start-up.	○	○	Page 114, Section 8.12	
Digital clipping function		Allows the maximum value and the minimum value of a digital output value to be fixed at 16000 and 0 or -16000 respectively if a voltage or current exceeding the input range is input.	○	○	Page 118, Section 8.13	

Item	Description	Available or not		Reference
		Main* ¹	Extension* ¹	
Difference conversion function	Subtracts the difference conversion reference value from a digital operation value and stores the obtained value into the remote register.	○	○	Page 123, Section 8.14
Trigger conversion function	Provides A/D conversion in accordance with the input of Trigger conversion request.	○	○	Page 128, Section 8.15
	Trigger conversion request that is input to the extension input module via an external device also allows A/D conversion.	○	×	
CC-Link IE Field Network synchronous communication function	Performs A/D conversion with a synchronization period of the master station that supports the CC-Link IE Field Network synchronous communication function. This makes it possible to synchronize the operation with other slave stations sharing the same network.	○	○	Page 136, Section 8.16
Error notification function	Notifies an error to the master station by the remote input signal if a moderate error or a major error occurs in the A/D converter module.	○	○	Page 143, Section 8.17
Functions with an extension I/O module connected	The main A/D converter module permits the connection of one extension I/O module. <ul style="list-style-type: none"> • With an extension input module connected, remote output signals of the main A/D converter module can be assigned to remote input signals of the extension input module connected. • With an extension output module connected, remote input signals of the main A/D converter module can be assigned to remote output signals of the extension output module connected. Functions unique to an extension I/O module can also be used.	○	×	Page 146, Section 8.18.1
Functions with an extension analog module connected	The main A/D converter module permits the connection of one extension A/D converter module. With the extension A/D converter module connected, A/D conversion processing of up to eight channels is possible.	○	○	Page 151, Section 8.18.2
	The main A/D converter module permits the connection of one extension D/A converter module. With the extension D/A converter module connected, A/D conversion processing of four channels and D/A conversion processing of four channels is possible.	○	×	Page 152, Section 8.18.3
CC-Link IE Field Network diagnostic function	Allows the presence or absence of a network error to be checked by accessing the engineering tool connected to the CPU module.	○	×	Page 153, Section 8.19
Automatic detection of connected device	Automatically generates "List of devices" and "Device map area" of the device supporting iQSS connected to the master module with an engineering tool.	○	×	 iQ Sensor Solution Reference Manual
Sensor parameter read/write	Reads or writes parameters of the device supporting iQSS.	○	×	 iQ Sensor Solution Reference Manual
Data backup/restoration	Backs up the slave module information in the SD memory card. Also restores the slave module information backed up in the SD memory card.	○	×	 iQ Sensor Solution Reference Manual

*1 "Main" and "Extension" indicate the following modules, respectively:

Main: Main A/D converter module

Extension: Extension A/D converter module

*2 The extension A/D converter module does not support user range.

3.5 List of Remote I/O Signals

This section lists I/O signals for a master/local module.

The I/O signal assignment shown assumes that the remote I/O signals of the main module are assigned to RX0 to RX1F and RY0 to RY1F.

Remote input (RX) indicates the input signal from A/D converter module to master/local module.

Remote output (RY) indicates the output signal from master/local module to A/D converter module.

The remote I/O signals of the main A/D converter module and extension module are assigned as shown below.

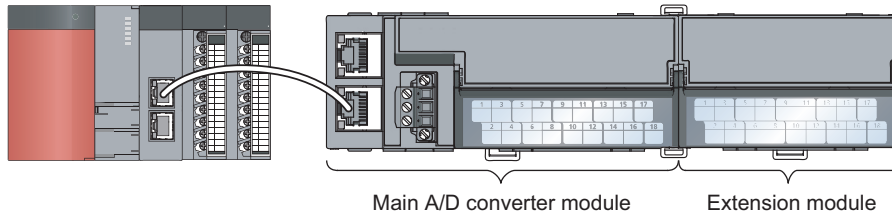

Module	Remote input (RX)	Remote output (RY)
Main A/D converter module	RX0 to RX1F	RY0 to RY1F
Extension module	RX20 to RX2F	RY20 to RY2F

For details on the remote I/O signals, refer to the following:

-  Page 190, Appendix 1

3.5.1 Main A/D converter module



Module type	Remote input		Remote output	
	Signal direction: Main A/D converter module → Master/local module		Signal direction: Master/local module → Main A/D converter module	
	Device No.	Description	Device No.	Description
Main A/D converter module	RX0	Use prohibited	RY0	Use prohibited
	RX1	Use prohibited	RY1	Use prohibited
	RX2	Use prohibited	RY2	Use prohibited
	RX3	Use prohibited	RY3	Use prohibited
	RX4	Use prohibited	RY4	Use prohibited
	RX5	Use prohibited	RY5	Use prohibited
	RX6	Use prohibited	RY6	Use prohibited
	RX7	Warning flag	RY7	Use prohibited
	RX8	Use prohibited	RY8	Use prohibited
	RX9	Initial data setting completion flag	RY9	Initial data setting request flag
	RXA	Error flag	RYA	Error clear request flag
	RXB	Remote READY	RYB	Use prohibited
	RXC	Use prohibited	RYC	Use prohibited
	RXD	Use prohibited	RYD	Use prohibited
	RXE	Use prohibited	RYE	Use prohibited
	RXF	Use prohibited	RYF	Use prohibited
	RX10	CH1 A/D conversion completed flag	RY10	Use prohibited
	RX11	CH2 A/D conversion completed flag	RY11	Use prohibited
	RX12	CH3 A/D conversion completed flag	RY12	Use prohibited
	RX13	CH4 A/D conversion completed flag	RY13	Use prohibited
	RX14	CH1 Difference conversion state flag	RY14	CH1 Difference conversion trigger
	RX15	CH2 Difference conversion state flag	RY15	CH2 Difference conversion trigger
	RX16	CH3 Difference conversion state flag	RY16	CH3 Difference conversion trigger
	RX17	CH4 Difference conversion state flag	RY17	CH4 Difference conversion trigger
	RX18	Alert output signal	RY18	Use prohibited
	RX19	Trigger conversion completed flag	RY19	Trigger conversion request
	RX1A	Use prohibited	RY1A	Trigger conversion completed clear request
	RX1B	Use prohibited	RY1B	Use prohibited
	RX1C	Input signal error detection signal	RY1C	Use prohibited
	RX1D	Maximum value/minimum value reset completed flag	RY1D	Maximum value/minimum value reset request
RX1E	Use prohibited	RY1E	Use prohibited	
RX1F	External power supply monitor status flag (for extension output module)	RY1F	External power supply monitor request flag (for extension output module)	

Point

Do not use any "Use prohibited" remote I/O signals. Doing so may result in an accident due to an incorrect output or malfunction.

(1) Remote I/O signals of extension modules

The remote I/O signals differ depending on the model of extension module.

- For the extension A/D converter module, refer to  Page 34, Section 3.5.2.
- For the extension D/A converter module, refer to  CC-Link IE Field Network Digital-Analog Converter Module User's Manual.
- For the extension I/O module, refer to  CC-Link IE Field Network Remote I/O Module User's Manual.

3.5.2 Extension A/D converter module

Module type	Remote input		Remote output	
	Signal direction: Extension A/D converter module→Master/local module		Signal direction: Master/local module→Extension A/D converter module	
	Device No.	Description	Device No.	Description
Extension A/D converter module	RX20	CH1 A/D conversion completed flag	RY20	Use prohibited
	RX21	CH2 A/D conversion completed flag	RY21	Use prohibited
	RX22	CH3 A/D conversion completed flag	RY22	Use prohibited
	RX23	CH4 A/D conversion completed flag	RY23	Use prohibited
	RX24	CH1 Difference conversion state flag	RY24	CH1 Difference conversion trigger
	RX25	CH2 Difference conversion state flag	RY25	CH2 Difference conversion trigger
	RX26	CH3 Difference conversion state flag	RY26	CH3 Difference conversion trigger
	RX27	CH4 Difference conversion state flag	RY27	CH4 Difference conversion trigger
	RX28	Alert output signal	RY28	Use prohibited
	RX29	Trigger conversion completed flag	RY29	Trigger conversion request
	RX2A	Use prohibited	RY2A	Trigger conversion completed clear request
	RX2B	Use prohibited	RY2B	Use prohibited
	RX2C	Input signal error detection signal	RY2C	Use prohibited
	RX2D	Maximum value/minimum value reset completed flag	RY2D	Maximum value/minimum value reset request
	RX2E	Use prohibited	RY2E	Use prohibited
RX2F	External power supply READY flag	RY2F	Use prohibited	

Point

Do not use any "Use prohibited" remote I/O signals. Doing so may result in an accident due to an incorrect output or malfunction.

3.6 List of Remote Registers

This section lists remote registers for a master/local module.

The remote register assignment shown assumes that the remote registers of the main module are assigned to RWr0 to RWrF and RWw0 to RWwF.

Remote register (RWr) is the information input from A/D converter module to master/local module.

Remote register (RWw) is the information output from master/local module to A/D converter module.

The remote registers of the main A/D converter module and extension module are assigned as shown below.

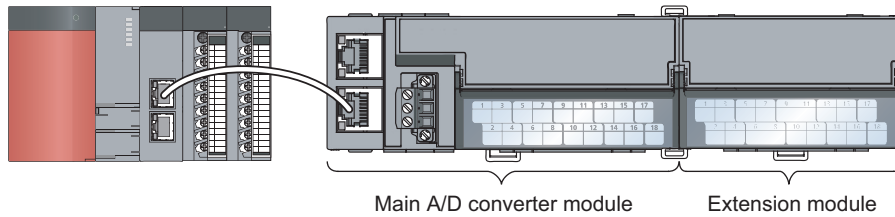

Module	Remote register (RWr)	Remote register (RWw)
Main A/D converter module	RWr0 to RWrF	RWw0 to RWwF
Extension module	(depends on the type of the extension module)	

For details on the remote register, refer to the following:

- Page 202, Appendix 2

3.6.1 Main A/D converter module

Module type	Remote register (RWr)		Remote register (RWw)	
	Signal direction: Main A/D converter module → Master/local module		Signal direction: Master/local module → Main A/D converter module	
	Device No.	Description	Device No.	Description
Main A/D converter module	RWr0	Latest error code	RWw0	Use prohibited
	RWr1	Latest warning code	RWw1	Use prohibited
	RWr2	CH1 Digital operation value	RWw2	CH1 Shifting amount to conversion value
	RWr3	CH2 Digital operation value	RWw3	CH2 Shifting amount to conversion value
	RWr4	CH3 Digital operation value	RWw4	CH3 Shifting amount to conversion value
	RWr5	CH4 Digital operation value	RWw5	CH4 Shifting amount to conversion value
	RWr6	CH1 Difference conversion reference value	RWw6	Use prohibited
	RWr7	CH2 Difference conversion reference value	RWw7	Use prohibited
	RWr8	CH3 Difference conversion reference value	RWw8	Use prohibited
	RWr9	CH4 Difference conversion reference value	RWw9	Use prohibited
	RWrA	Input signal error detection flag	RWwA	Use prohibited
	RWrB	Alert output flag	RWwB	Use prohibited
	RWrC	Use prohibited	RWwC	Use prohibited
	RWrD	Use prohibited	RWwD	Use prohibited
	RWrE	Use prohibited	RWwE	Use prohibited
	RWrF ^{*1}	Use prohibited	RWwF ^{*1}	Use prohibited



*1 The registers RWrF and RWwF are used by the system in synchronous communication mode.

Point

Do not read/write data from/to any "Use prohibited" remote registers. Doing so may result in an accident due to an incorrect output or malfunction.

(1) Remote registers of extension analog modules

The remote registers differ depending on the model of extension analog module.

- For the extension A/D converter module, refer to  Page 37, Section 3.6.2.
- For the extension D/A converter module, refer to  CC-Link IE Field Network Digital-Analog Converter Module User's Manual.

3.6.2 Extension A/D converter module

Module type	Remote register (RWr)		Remote register (RWw)	
	Signal direction: Extension A/D converter module → Master/local module		Signal direction: Master/local module → Extension A/D converter module	
	Device No.	Description	Device No.	Description
Extension module	RWr10	Use prohibited	RWw10	Use prohibited
	RWr11	Use prohibited	RWw11	Use prohibited
	RWr12	CH1 Digital operation value	RWw12	CH1 Shifting amount to conversion value
	RWr13	CH2 Digital operation value	RWw13	CH2 Shifting amount to conversion value
	RWr14	CH3 Digital operation value	RWw14	CH3 Shifting amount to conversion value
	RWr15	CH4 Digital operation value	RWw15	CH4 Shifting amount to conversion value
	RWr16	CH1 Difference conversion reference value	RWw16	Use prohibited
	RWr17	CH2 Difference conversion reference value	RWw17	Use prohibited
	RWr18	CH3 Difference conversion reference value	RWw18	Use prohibited
	RWr19	CH4 Difference conversion reference value	RWw19	Use prohibited
	RWr1A	Input signal error detection flag	RWw1A	Use prohibited
	RWr1B	Alert output flag	RWw1B	Use prohibited
	RWr1C	Use prohibited	RWw1C	Use prohibited
	RWr1D	Use prohibited	RWw1D	Use prohibited
	RWr1E	Use prohibited	RWw1E	Use prohibited
	RWr1F	Use prohibited	RWw1F	Use prohibited

Point

Do not read or write the data from/to any "Use prohibited" remote registers. Doing so may result in an accident due to an incorrect output or malfunction.

3.7 List of Remote Buffer Memory Areas

This section lists the remote buffer memory areas of the A/D converter module.

The remote buffer memory areas of the main module and extension module are assigned as shown below.

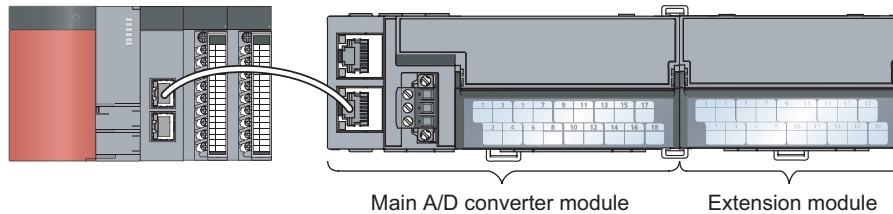

Ex. How the individual areas of remote buffer memory are shown in the manual

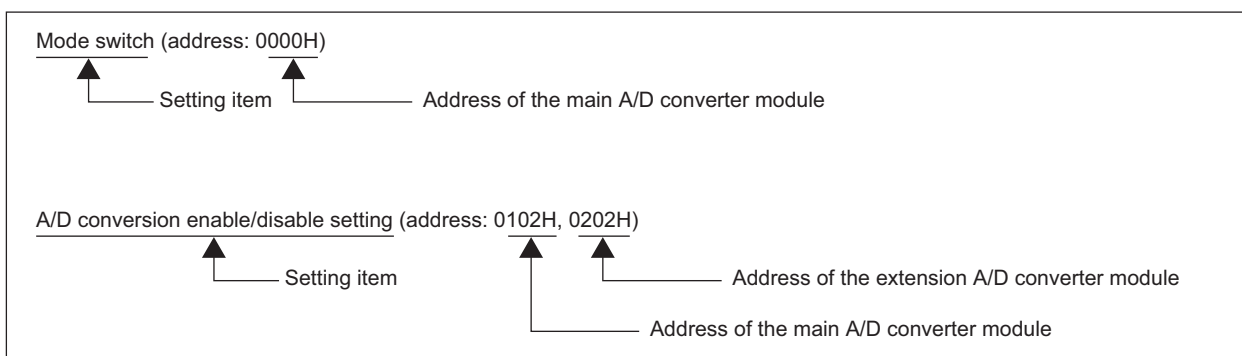

For details on the remote buffer memory, refer to the following:

- Page 206, Appendix 3

○: Access permitted, ×: Access not permitted

Remote buffer memory address		Area	Target	Access method		
Decimal	Hexadecimal			CC IE Field configuration of the engineering tool	REMFR instruction, REMTO instruction ^{*1}	
0 to 255	0000H to 00FFH	Parameter area	Station-based parameter data	○ ^{*2}	○	
256 to 511	0100H to 01FFH		Module-based parameter data			Main module
512 to 767	0200H to 02FFH					Extension module 1
768 to 1279	0300H to 04FFH		System area			
1280 to 1535	0500H to 05FFH	Monitor area	Station-based monitor data	×	○	
1536 to 1791	0600H to 06FFH		Module-based monitor data			Main module
1792 to 2047	0700H to 07FFH					Extension module 1
2048 to 2559	0800H to 09FFH		System area			
2560 to 4095	0A00H to 0FFFH	Error history area	Station-based error history data	○ ^{*2}	○	
4096 to 4351	1000H to 10FFH	Module control data area	Station-based control data	×	○	
4352 to 4607	1100H to 11FFH		Module-based control data			Main module
4608 to 4863	1200H to 12FFH					Extension module 1
4864 to 5375	1300H to 14FFH		System area			

*1 For the REMFR and REMTO instructions, refer to the following:

User's manual for the master/local module used

*2 For the access method, refer to the following:

- Parameter area (Page 70, Section 7.1)
- Error history area (Page 169, Section 11.1)



Do not access any system area using the REMFR or REMTO instruction. Doing so may cause malfunction.

3.7.1 Main A/D converter module

(1) Parameter area (address: 0000H to 04FFH)

For the parameter area, parameters can be set by means of the CC IE Field configuration of the engineering tool, or the REMTO instruction.

The parameters in the parameter area are backed up to the non-volatile memory.

The parameters backed up to the non-volatile memory are read out to the parameter area when the module power supply is turned off and on or the module is reset by remote reset.

For the parameters written from the parameter settings of the CC IE Field configuration of the engineering tool, the write to the non-volatile memory is also completed at the same time. For the parameters written using the REMTO instruction, the timing of the write to the non-volatile memory is at the time of turning on Initial data setting request flag (RY9) from off. At this time, even an invalid parameter is written to the non-volatile memory as well. With an invalid parameter written, turning off and on the power supply causes the invalid parameter to be read from the non-volatile memory, resulting in the error code being stored into Latest error code (RWr0). Take corrective action with reference to the error code list. (Page 173, Section 11.2)

Type	Address		Description	Default value ^{*1}	Read/Write ^{*2}	Necessity of RY9 ^{*3}
	Decimal	Hexadecimal				
Station-based parameter data	0	0000H	Mode switch	0009H	R/W	○
	1	0001H	Conversion speed switch	0000H	R/W	○
	2	0002H	Trigger conversion signal assignment (for external signal assignment function)	FFFFH	R/W	○
	3	0003H	Input signal error detection signal assignment (for external signal assignment function)	FFFFH	R/W	○
	4	0004H	Alert output signal assignment (for external signal assignment function)	FFFFH	R/W	○
	5	0005H	Error flag assignment (for external signal assignment function)	FFFFH	R/W	○
	6	0006H	Warning flag assignment (for external signal assignment function)	FFFFH	R/W	○
	7	0007H	Cyclic data update watch time setting	0000H	R/W	○
	8 to 15	0008H to 000FH	System area	—	—	—
	16	0010H	Input response time setting	0005H	R/W	○
	17	0011H	Digital output HOLD/CLEAR setting	0000H	R/W	○
	18 to 255	0012H to 00FFH	System area	—	—	—

Type	Address		Description	Default value ^{*1}	Read/Write ^{*2}	Necessity of RY9 ^{*3}
	Decimal	Hexadecimal				
Main module Module-based parameter data	256, 257	0100H, 0101H	System area	—	—	—
	258	0102H	A/D conversion enable/disable setting	0000H	R/W	○
	259	0103H	Range setting	0000H	R/W	○
	260	0104H	Averaging process setting	0000H	R/W	○
	261	0105H	CH1 Time average/Count average/Moving average	0	R/W	○
	262	0106H	CH2 Time average/Count average/Moving average	0	R/W	○
	263	0107H	CH3 Time average/Count average/Moving average	0	R/W	○
	264	0108H	CH4 Time average/Count average/Moving average	0	R/W	○
	265	0109H	Input signal error detection setting	0000H	R/W	○
	266 to 269	010AH to 010DH	System area	—	—	—
	270	010EH	Alert output setting	000FH	R/W	○
	271	010FH	CH1 Process alarm lower lower limit value	0	R/W	○
	272	0110H	CH1 Process alarm lower upper limit value	0	R/W	○
	273	0111H	CH1 Process alarm upper lower limit value	0	R/W	○
	274	0112H	CH1 Process alarm upper upper limit value	0	R/W	○
	275	0113H	CH2 Process alarm lower lower limit value	0	R/W	○
	276	0114H	CH2 Process alarm lower upper limit value	0	R/W	○
	277	0115H	CH2 Process alarm upper lower limit value	0	R/W	○
	278	0116H	CH2 Process alarm upper upper limit value	0	R/W	○
	279	0117H	CH3 Process alarm lower lower limit value	0	R/W	○
	280	0118H	CH3 Process alarm lower upper limit value	0	R/W	○
	281	0119H	CH3 Process alarm upper lower limit value	0	R/W	○
	282	011AH	CH3 Process alarm upper upper limit value	0	R/W	○
	283	011BH	CH4 Process alarm lower lower limit value	0	R/W	○
	284	011CH	CH4 Process alarm lower upper limit value	0	R/W	○
	285	011DH	CH4 Process alarm upper lower limit value	0	R/W	○
	286	011EH	CH4 Process alarm upper upper limit value	0	R/W	○
	287	011FH	Digital clipping enable/disable setting	000FH	R/W	○
	288	0120H	Scaling enable/disable setting	000FH	R/W	○
	289	0121H	CH1 Scaling lower limit value	0	R/W	○
	290	0122H	CH1 Scaling upper limit value	0	R/W	○
	291	0123H	CH2 Scaling lower limit value	0	R/W	○
	292	0124H	CH2 Scaling upper limit value	0	R/W	○
293	0125H	CH3 Scaling lower limit value	0	R/W	○	
294	0126H	CH3 Scaling upper limit value	0	R/W	○	
295	0127H	CH4 Scaling lower limit value	0	R/W	○	
296	0128H	CH4 Scaling upper limit value	0	R/W	○	
297 to 511	0129H to 01FFH	System area	—	—	—	
Extension module 1 Module-based parameter data	512 to 767	0200H to 02FFH	The remote buffer memory areas of the connected extension module are assigned.	—	—	—
—	768 to 1279	0300H to 04FFH	System area	—	—	—



*1 This value is the value of factory default or the value of initialization by Parameter area initialization command (address: 1002H).

*2 This shows whether reading/writing data from/to a program is possible.
R: Readable
W: Writable

*3 This shows the items enabled by turning on and off Initial data setting request flag (RY9).

(a) Parameter area of extension modules

The remote buffer memory areas differ depending on the model of extension module.

- For the extension A/D converter module, refer to  Page 44, Section 3.7.2 (1).
- For the extension D/A converter module, refer to  CC-Link IE Field Network Digital-Analog Converter Module User's Manual.
- For the extension I/O module, refer to  CC-Link IE Field Network Remote I/O Module User's Manual.

(2) Monitoring area (address: 0500H to 09FFH)

Type	Address		Description	Default value*1	Read/Write*2
	Decimal	Hexadecimal			
Station-based monitor data	1280 to 1535	0500H to 05FFH	System area	—	—
Main module Module-based monitor data	1536	0600H	System area	—	—
	1537	0601H	CH1 Maximum value	0	R
	1538	0602H	CH1 Minimum value	0	R
	1539	0603H	CH2 Maximum value	0	R
	1540	0604H	CH2 Minimum value	0	R
	1541	0605H	CH3 Maximum value	0	R
	1542	0606H	CH3 Minimum value	0	R
	1543	0607H	CH4 Maximum value	0	R
	1544	0608H	CH4 Minimum value	0	R
	1545 to 1791	0609H to 06FFH	System area	—	—
Extension module 1 Module-based monitor data	1792 to 2047	0700H to 07FFH	The remote buffer memory areas of the connected extension module are assigned.	—	—
—	2048 to 2559	0800H to 09FFH	System area	—	—

*1 Value at the time of turning off and on the module power supply or at the time of remote reset.



*2 This shows whether reading/writing data from/to a program is possible.

R: Readable

W: Writable

(a) Monitor area of extension modules

The remote buffer memory differs depending on the model of the extension module.

- For the extension A/D converter module, refer to  Page 45, Section 3.7.2 (2).
- For the extension D/A converter module, refer to  CC-Link IE Field Network Digital-Analog Converter Module User's Manual.
- For the extension I/O module, refer to  CC-Link IE Field Network Remote I/O Module User's Manual.

(3) Error history area (address: 0A00H to 0FFFH)

Type	Address		Description	Default value ^{*1}	Read/Write ^{*2}	
	Decimal	Hexadecimal				
Station-based error history data	2560	0A00H	Error history data 1	Error code	0000H	R
	2561	0A01H		Order of generation	0000H	R
	2562	0A02H		[Error time] First two digits of the year/Last two digits of the year	0000H	R
	2563	0A03H		[Error time] Month/Day	0000H	R
	2564	0A04H		[Error time] Hour/Minute	0000H	R
	2565	0A05H		[Error time] Second/00H (Fixed)	0000H	R
	2566	0A06H		CH1 Digital operation value	0000H	R
	2567	0A07H		CH2 Digital operation value	0000H	R
	2568	0A08H		CH3 Digital operation value	0000H	R
	2569	0A09H		CH4 Digital operation value	0000H	R
	2570 to 2575	0A0AH to 0A0FH		System area	—	—
	2576 to 2591	0A10H to 0A1FH	Error history data 2	Same as Error history data 1.		
	2592 to 2607	0A20H to 0A2FH	Error history data 3	Same as Error history data 1.		
	2608 to 2623	0A30H to 0A3FH	Error history data 4	Same as Error history data 1.		
	2624 to 2639	0A40H to 0A4FH	Error history data 5	Same as Error history data 1.		
	2640 to 2655	0A50H to 0A5FH	Error history data 6	Same as Error history data 1.		
	2656 to 2671	0A60H to 0A6FH	Error history data 7	Same as Error history data 1.		
	2672 to 2687	0A70H to 0A7FH	Error history data 8	Same as Error history data 1.		
	2688 to 2703	0A80H to 0A8FH	Error history data 9	Same as Error history data 1.		
	2704 to 2719	0A90H to 0A9FH	Error history data 10	Same as Error history data 1.		
	2720 to 2735	0AA0H to 0AAFH	Error history data 11	Same as Error history data 1.		
	2736 to 2751	0AB0H to 0ABFH	Error history data 12	Same as Error history data 1.		
	2752 to 2767	0AC0H to 0ACFH	Error history data 13	Same as Error history data 1.		
	2768 to 2783	0AD0H to 0ADFH	Error history data 14	Same as Error history data 1.		
	2784 to 2799	0AE0H to 0AEFH	Error history data 15	Same as Error history data 1.		
	2800 to 4095	0AF0H to 0FFFH	System area	—	—	

*1 This value is the value of factory default or the value of initialization by Error history clear command (address: 1000H).

*2 This shows whether reading/writing data from/to a program is possible.

R: Readable

W: Writable

(4) Module control data area (address: 1000H to 14FFH)

Type	Address		Description	Default value *1	Read/Write *2
	Decimal	Hexadecimal			
Station-based control data	4096	1000H	Error history clear command	0	R/W
	4097	1001H	Error history clear completed	0	R
	4098	1002H	Parameter area initialization command	0	R/W
	4099	1003H	Parameter area initialization completed	0	R
	4100	1004H	Module operation information initialization command	0	R/W
	4101	1005H	Module operation information initialization completed	0	R
Station-based control data	4102 to 4351	1006H to 10FFH	System area	—	—
Main module Module-based control data	4352 to 4607	1100H to 11FFH	System area	—	—
Extension module 1 Module-based control data	4608 to 4863	1200H to 12FFH	The remote buffer memory areas of the connected extension module are assigned.	—	—
—	4864 to 5375	1300H to 14FFH	System area	—	—

*1 Value at the time of turning off and on the module power supply or at the time of remote reset.



*2 This shows whether reading/writing data from/to a program is possible.

R: Readable

W: Writable

(a) Module control data area of the extension module

The remote buffer memory differs depending on the model of the extension module.

- For the extension A/D converter module, refer to  Page 45, Section 3.7.2 (3).
- For the extension D/A converter module, refer to  CC-Link IE Field Network Digital-Analog Converter Module User's Manual.
- For the extension I/O module, refer to  CC-Link IE Field Network Remote I/O Module User's Manual.

3.7.2 Extension A/D converter module

(1) Parameter area (address: 0200H to 02FFH)

Type	Address		Description	Default value*1	Read/Write*2	Necessity of RY9*3
	Decimal	Hexadecimal				
Extension module Module-based parameter data	512	0200H	Extension module identification code	0000H	R/W	○
	513	0201H	System area	—	—	—
	514	0202H	A/D conversion enable/disable setting	0000H	R/W	○
	515	0203H	Range setting	0000H	R/W	○
	516	0204H	Averaging process setting	0000H	R/W	○
	517	0205H	CH1 Time average/Count average/Moving average	0	R/W	○
	518	0206H	CH2 Time average/Count average/Moving average	0	R/W	○
	519	0207H	CH3 Time average/Count average/Moving average	0	R/W	○
	520	0208H	CH4 Time average/Count average/Moving average	0	R/W	○
	521	0209H	Input signal error detection setting	0000H	R/W	○
	522 to 525	020AH to 020DH	System area	—	—	—
	526	020EH	Alert output setting	000FH	R/W	○
	527	020FH	CH1 Process alarm lower lower limit value	0	R/W	○
	528	0210H	CH1 Process alarm lower upper limit value	0	R/W	○
	529	0211H	CH1 Process alarm upper lower limit value	0	R/W	○
	530	0212H	CH1 Process alarm upper upper limit value	0	R/W	○
	531	0213H	CH2 Process alarm lower lower limit value	0	R/W	○
	532	0214H	CH2 Process alarm upper lower limit value	0	R/W	○
	533	0215H	CH2 Process alarm upper lower limit value	0	R/W	○
	534	0216H	CH2 Process alarm upper upper limit value	0	R/W	○
	535	0217H	CH3 Process alarm lower lower limit value	0	R/W	○
	536	0218H	CH3 Process alarm lower upper limit value	0	R/W	○
	537	0219H	CH3 Process alarm upper lower limit value	0	R/W	○
	538	021AH	CH3 Process alarm upper upper limit value	0	R/W	○
	539	021BH	CH4 Process alarm lower lower limit value	0	R/W	○
	540	021CH	CH4 Process alarm lower upper limit value	0	R/W	○
	541	021DH	CH4 Process alarm upper lower limit value	0	R/W	○
	542	021EH	CH4 Process alarm upper upper limit value	0	R/W	○
	543	021FH	Digital clipping enable/disable setting	000FH	R/W	○
	544	0220H	Scaling enable/disable setting	000FH	R/W	○
	545	0221H	CH1 Scaling lower limit value	0	R/W	○
	546	0222H	CH1 Scaling upper limit value	0	R/W	○
	547	0223H	CH2 Scaling lower limit value	0	R/W	○
	548	0224H	CH2 Scaling upper limit value	0	R/W	○
	549	0225H	CH3 Scaling lower limit value	0	R/W	○
	550	0226H	CH3 Scaling upper limit value	0	R/W	○
	551	0227H	CH4 Scaling lower limit value	0	R/W	○
	552	0228H	CH4 Scaling upper limit value	0	R/W	○
	553 to 767	0229H to 02FFH	System area	—	—	—

- *1 This value is the value of factory default or the value of initialization by Parameter area initialization command (address: 1002H).
- *2 This shows whether reading/writing data from/to a program is possible.
R: Readable
W: Writable
- *3 This shows the items enabled by turning on and off Initial data setting request flag (RY9).

(2) Monitor area (address: 0700H to 07FFH)

Type	Address		Description	Default value ^{*1}	Read/Write ^{*2}
	Decimal	Hexadecimal			
Extension module 1 Module-based monitor data	1792	0700H	Extension module identification code	0000H	R
	1793	0701H	CH1 Maximum value	0	R
	1794	0702H	CH1 Minimum value	0	R
	1795	0703H	CH2 Maximum value	0	R
	1796	0704H	CH2 Minimum value	0	R
	1797	0705H	CH3 Maximum value	0	R
	1798	0706H	CH3 Minimum value	0	R
	1799	0707H	CH4 Maximum value	0	R
	1800	0708H	CH4 Minimum value	0	R
	1801 to 2047	0709H to 07FFH	System area	—	—

- *1 Value at the time of turning off and on the module power supply or at the time of remote reset.
- *2 This shows whether reading/writing data from/to a program is possible.
R: Readable
W: Writable

(3) Module control data area (address: 1200H to 12FFH)

Type	Address		Description	Default value ^{*1}	Read/Write ^{*2}
	Decimal	Hexadecimal			
Extension module 1 Module-based control data	4608 to 4863	1200H to 12FFH	System area	—	—

- *1 Value at the time of turning off and on the module power supply or at the time of remote reset.
- *2 This shows whether reading/writing data from/to a program is possible.
R: Readable
W: Writable

CHAPTER 4 PROCEDURES BEFORE OPERATION

This chapter describes the procedures before operation.

Check box

Setting a station number

Set the station number of the main A/D converter module.



Page 51, Section 6.1



Connection

When using an extension module, connect the extension module to the main A/D converter module.
After that, mount the main A/D converter module on a DIN rail.



Page 52, Section 6.2
Page 54, Section 6.3



Wiring

Carry out wiring of a power supply, Ethernet cables, and external devices to the main A/D converter module.
To use an extension module, carry out wiring of a power supply and external devices to the extension module.



Page 54, Section 6.3
Page 59, Section 6.4
Page 61, Section 6.5



Parameter settings and programming

Set parameters and create a program.



Page 70, Section 7.1
Page 77, Section 7.2*¹
Page 156, CHAPTER 9



Offset/gain setting

If the user range is necessary, set up the offset/gain setting.



Page 84, Section 7.3

*1 To replace the module, refer to the point below.

Point

To replace the module, follow the procedure described below:

- Turn off the module power supply and remove the A/D converter module.
 - Prepare a new A/D converter module and follow the illustration above as instructed from "Setting a station number" to "Parameter settings and programming". (No re-setting of network parameters of the master station is required.)
 - If necessary to use the user range, perform the offset/gain setting.
 - Carry out operation check and then restart the control.
-

Memo

CHAPTER 5 SYSTEM CONFIGURATION

This chapter describes how to configure the system using A/D converter modules.

For the configuration on CC-Link IE Field Network, refer to the following:

📖 User's manual for the master/local module used

5.1 System Configuration with A/D Converter Module

The following figure shows the system configuration including an A/D converter module.

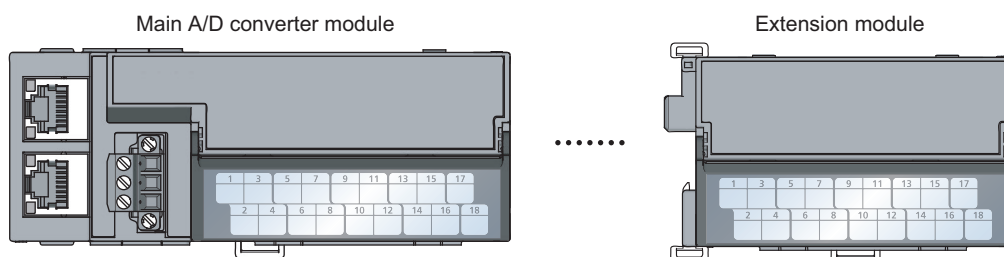

5.2 Applicable Systems

(1) Supported master station

For the use of an A/D converter module, select a product for the master station from the following list.

Model	First five digits of serial number
RJ71GF11-T2 RJ71EN71	(no restriction)
RD77GF32, RD77GF16, RD77GF8, RD77GF4	
LJ71GF11-T2 QJ71GF11-T2	14102 or later
QD77GF16	14111 or later

The above information of "supported master station" is information at the time of this revision.

For the latest information, refer to the CC-Link Partner Association's website.

www.cc-link.org

(2) Connectable modules

(a) Extension modules that can be connected to the main A/D converter module

Either one of the following extension modules can be connected to the main A/D converter module.

Classification	Model
Extension input module	NZ2EX2B1-16D
Extension output module	NZ2EX2B1-16T
	NZ2EX2B1-16TE
Extension A/D converter module	NZ2EX2B-60AD4
Extension D/A converter module	NZ2EX2B-60DA4

(b) Main modules to which the extension A/D converter module can be connected

The extension A/D converter module can be connected to either one of the following main modules.

Classification	Model
Main A/D converter module	NZ2GF2BN-60AD4
Main D/A converter module	NZ2GF2BN-60DA4

(3) Ethernet cables

For the specifications of the Ethernet cable, refer to the following:

 User's manual for the master/local module used

(4) Supported software package

Configuring and diagnosing the A/D converter module requires GX Works2 or GX Works3. According to the master station used, install the following version of GX Works2 or GX Works3.

Engineering tool	Software version
GX Works2	Version 1.525X or later
GX Works3	Version 1.005F or later

Point!

When the latest profile of the A/D converter module is necessary, please consult your local Mitsubishi representative.

The profile is a setting file that stores information required for the start-up, operation, and maintenance of devices supporting the CC-Link family. A module is added to "Module List" of "CC IE Field Configuration" window by profile registration to GX Works2 or GX Works3. For the profile registration, refer to the following.

 GX Works2 Version 1 Operating Manual (Common)

 GX Works3 Operating Manual

CHAPTER 6 INSTALLATION AND WIRING

This chapter describes the installation and wiring of the A/D converter module.

6.1 Station Number Setting

(1) Setting method

Set the station number with the rotary switch on the front of the module. Set the station number in the power-off state because the set value is enabled at power-on.

- The dial x10 is used to set the hundreds and tens place of a station number.
- The dial x1 is used to set the ones place of a station number.

Ex. For the station number 115, set the switch as shown below.

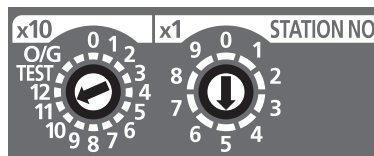

(2) Setting range

Set the station number, which can be from 1 to 120. A value other than 1 to 120 causes a communication error, resulting in the D LINK LED flashing.

Point

- While the module power supply is in an on state, changing the station number setting switch causes a minor error, resulting in the ERR. LED flashing. When the station number setting switch is set back to the previous state, the module recovers from the error after five seconds, resulting in the ERR. LED turning off.
- For the station number setting, avoid duplication with the other station numbers. Number duplication causes a communication error, which does not allow the D LINK LED to light up.

6.2 Installation Environment and Installation Position

6.2.1 Installation environment

(1) Installation location

Do not install the A/D converter module in places where:

- Ambient temperature is outside the range of 0 to 55°C;
- Ambient humidity is outside the range of 5 to 95% RH;
- Condensation occurs due to rapid temperature change;
- Corrosive gas or combustible gas is present;
- There are a high level of conductive powder such as dust and iron powder, oil mist, salinity, or organic solvent;
- It is exposed to direct sunlight;
- A strong electric field or strong magnetic field is generated; and
- The module is subject to vibration and shock.

(2) Installation surface

Install the A/D converter module on a flat surface. Unevenness on the installation surface causes application of an excessive force to the printed-circuit board, which may lead to a malfunction.

6.2.2 Installation position

When installing the A/D converter module in a control panel, provide a clearance of at least 60mm from the surroundings including adjacent structures and modules to ensure good ventilation and easy module change.

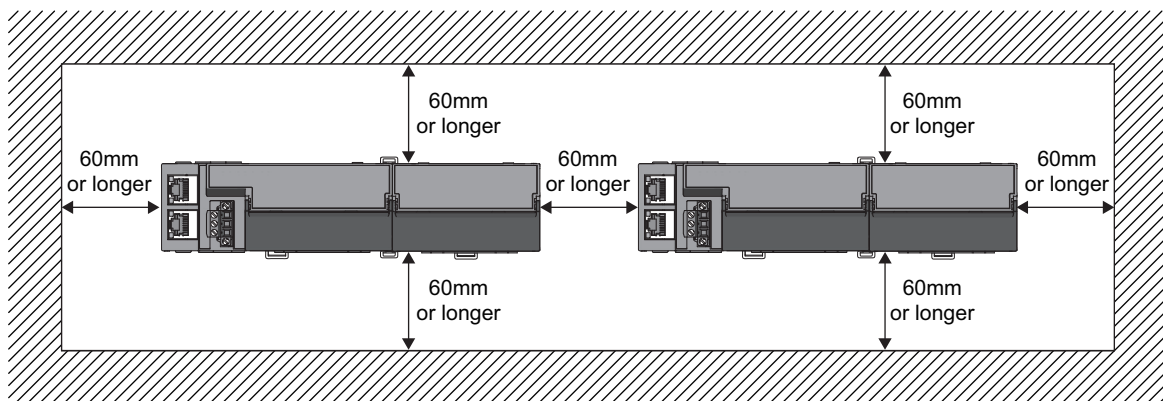

6.2.3 Installation direction

The A/D converter module can be installed in six directions.
Use a DIN rail to install the module.

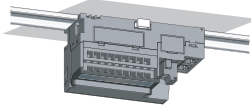

Downward installation

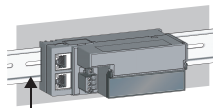

DIN rail
Horizontal installation

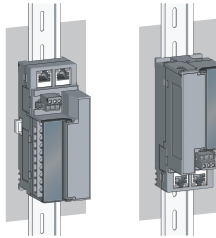

Vertical installation

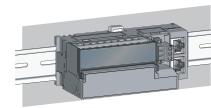

Horizontal installation
(upside down)

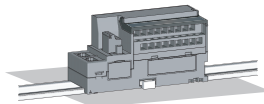

Upward installation

6.3 Installation

6.3.1 How to connect an extension module

(1) Connecting procedure

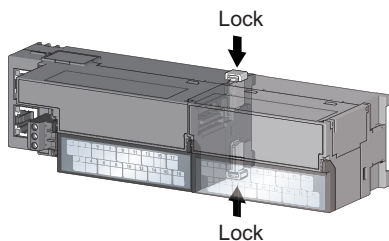
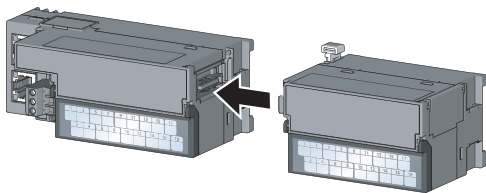
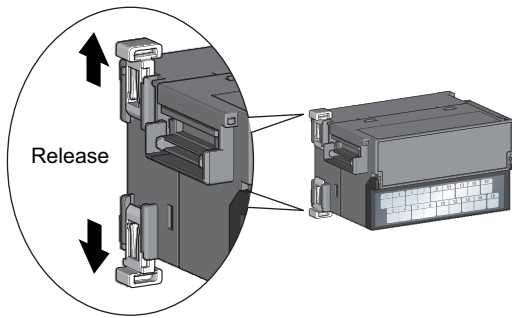
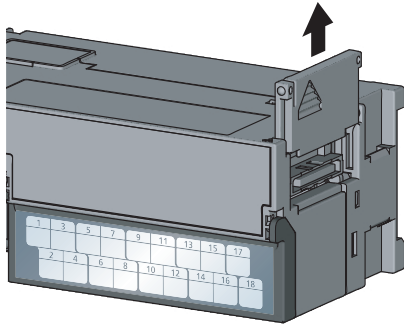

1. Remove the cover on the side of the main module. Save the removed cover without losing it.

2. Release the module joint levers (two points) on the side of the extension module. Slide the levers vertically.

3. Insert one module straight into the other so that the connectors of both modules engage.

4. Lock the module joint levers (two points) on the side of the extension module. Slide the levers toward the module.

Check that the modules are securely connected.

(2) Disconnecting procedure

Disconnect the extension module in a procedure opposite to the connecting procedure.

Point

-
- Shut off the external power supply for the system in all phases before connecting or disconnecting extension modules.
 - Lock the module joint levers securely. Failure to do so may cause malfunction, failure, or drop of the module.
-

6.3.2 How to mount modules on a DIN rail

Point

The usage instructions for a DIN rail stopper is shown as one example. Fix the module according to the manual of the DIN rail stopper used.

(1) Mounting procedure

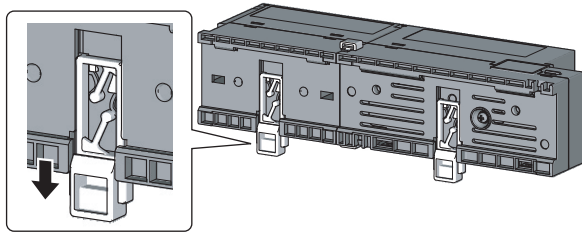

- 1. Pull down all DIN rail hooks on the back of the modules.**

The levers should be pulled down until it clicks.

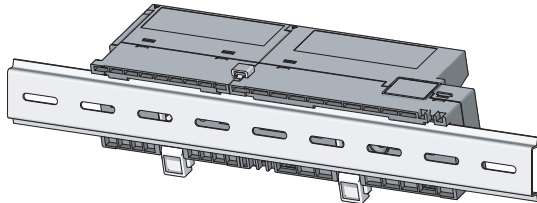

- 2. Hang the upper tabs of the modules on a DIN rail, and push the modules in position.**

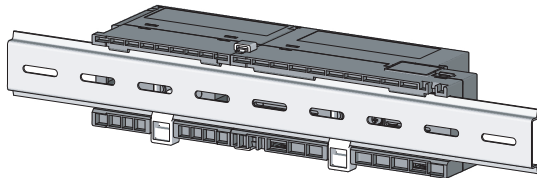

- 3. Lock the DIN rail hooks to the DIN rail to secure the modules in position.**

Push each hook up until it clicks. If the hooks are beyond the reach, use a tool such as a screwdriver.

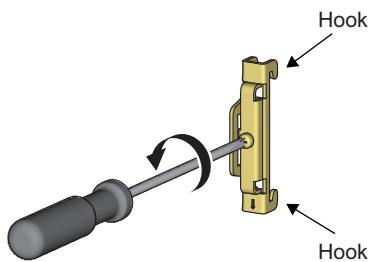

- 4. Loosen the screw on the DIN rail stopper.**

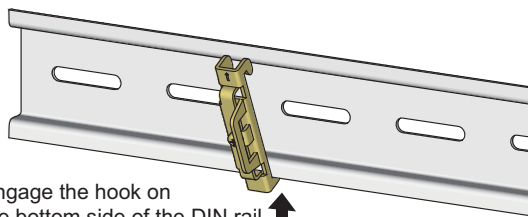

- 5. Hitch the bottom hook of the DIN rail stopper to the bottom of the DIN rail.**

Hitch the hook according to the orientation of the arrow on the front of the stopper.

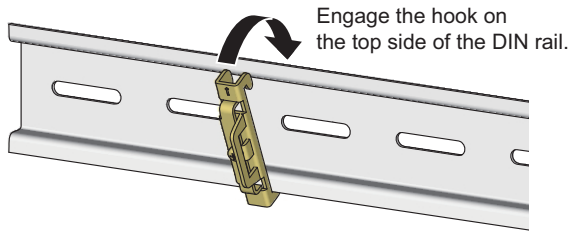

6. Hitch the upper hook of the DIN rail stopper to the top of the DIN rail.

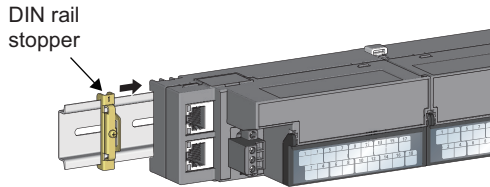

7. Slide the DIN rail stopper up to the left side of the modules.

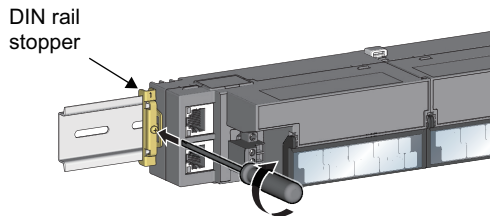

8. Hold the DIN rail stopper in the direction opposite to the arrow on the stopper and tighten the screw with a screwdriver.

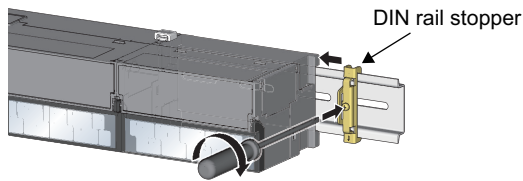

9. Install the DIN rail stopper on the right side of the module in the same procedure.

For the installation on the right side, be aware that the orientation of the DIN rail stopper is upside down.

Point

Do not slide modules from the edge of the DIN rail when mounting them. Doing so may damage the metal part located on the back of the module.

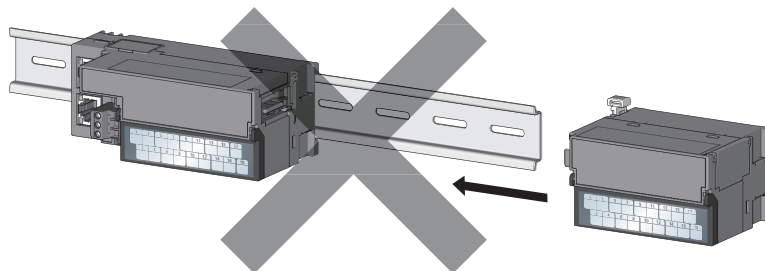

(2) Removal procedure

Remove the modules from the DIN rail in a procedure opposite to the mounting procedure.

(3) Applicable DIN rail model (compliant with IEC 60715)

- TH35-7.5Fe
- TH35-7.5Al

(4) Space between DIN rail mounting screws

When installing a DIN rail, tighten the screws at a pitch of 200mm or less.

(5) DIN rail stopper

Use a stopper that is attachable to the DIN rail.

6.4 Wiring to Terminal Block for Module Power Supply and FG

This section describes how to wire a terminal block for module power supply and FG to the main A/D converter module.

Note that the descriptions are the same for the extension A/D converter module.

(1) Tightening torque

Tighten the terminal block screws within the following specified torque range.

Tightening the screws too much may damage the module case.

Screw type	Tightening torque range
Terminal block mounting screw (M2.5)	0.2 to 0.3N·m
Terminal screw (M2.5)	0.5 to 0.6N·m

(2) Suitable wire

The table below shows the suitable wire for connection to the terminal block for module power supply and FG.

Diameter	Type	Material	Temperature rating
20 to 16 AWG	Stranded	Copper	75°C or higher

(3) Installing and removing the terminal block

To remove the terminal block, loosen the terminal block mounting screw with a flathead screwdriver.

To install the terminal block, tighten the terminal block mounting screw with a flathead screwdriver.

Failure to secure the terminal block may cause drop, short circuit, or malfunction.

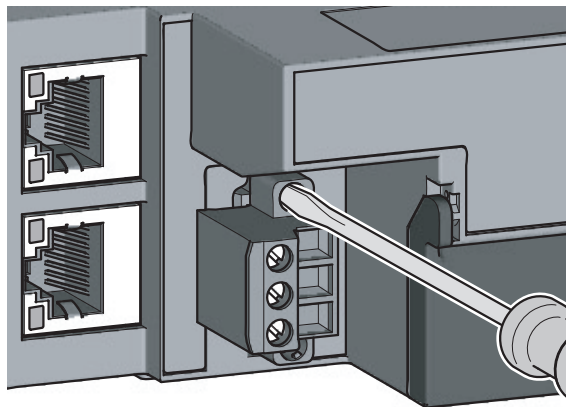

(4) Connecting and disconnecting a cable

To connect a cable, with the terminal screw loosened using a flathead screwdriver, insert the wire and then tighten the terminal screw.

To disconnect the cable, with the terminal screw loosened using a flathead screwdriver, pull out the wire.

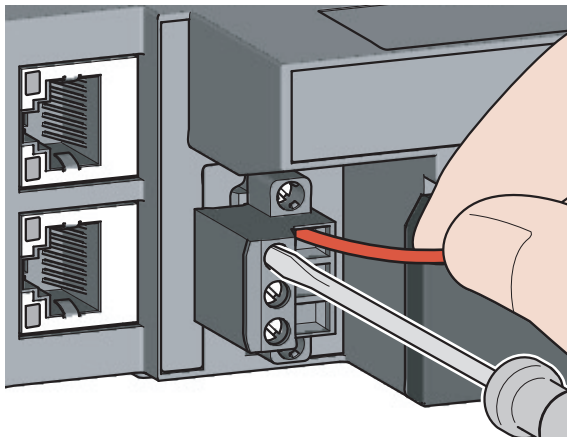

(5) Cable terminal processing

Strip the cable sheath approximately 10mm from the end.

To use a bar solderless terminal, connect it to the stripped part.

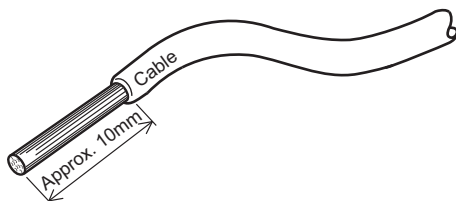

(6) List of bar solderless terminals

The following table lists recommended bar solderless terminals.

Product name	Model	Applicable wire size	Contact
Bar solderless terminal	TE 0.5-10	0.5mm ²	NICHIFU Co., Ltd.
	TE 0.75-10	0.75mm ²	
	TE 1.0-10	0.9 to 1.0mm ²	
	TE 1.5-10	1.25 to 1.5mm ²	
Bar solderless terminal tool	NH79	—	
Bar solderless terminal	AI 0.5-10WH	0.5mm ²	Phoenix Contact Co., Ltd.
	AI 0.75-10GY	0.75mm ²	
	AI 1-10RD	1.0mm ²	
	AI 1.5-10BK	1.5mm ²	
Bar solderless terminal tool	CRIMPFOX6	—	

6.5 Wiring of Ethernet Cable

(1) Connecting an Ethernet cable

(a) Connecting

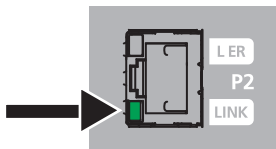
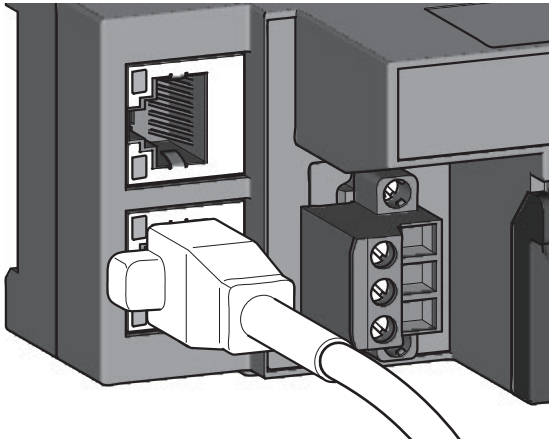

1. Turn off the module power supply of the main A/D converter module and the power supply of the external devices.
2. With attention to the orientation of the cable, push the Ethernet cable connector into the main A/D converter module until it clicks.
3. Power on the module.
4. Power on the external device.
5. Check if the LINK LED on the port into which the Ethernet cable is connected is on.

- The time taken for the LINK LED to turn on after connection of the cable may vary. The LINK LED normally turns on in a few seconds. However, if link-up processing is repeated due to a condition of a device on the line, the longer time may be required. If the LINK LED does not turn on, refer to the following and take a corrective action.
☞ Page 184, Section 11.4.1 (8)

- PORT1 connector and PORT2 connector need not to be distinguished. When only one connector is used in star topology, either PORT1 connector or PORT2 connector can be used.

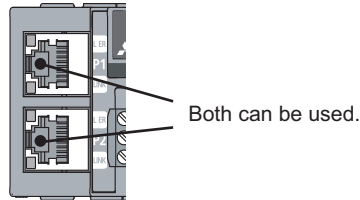

- When two connectors are used in line topology or ring topology, there is no restriction on the connection combination of PORT1 connector and PORT 2 connector. For example, the connection from PORT1 to PORT1 and the connection from PORT1 to PORT2 are both possible.

Connection from port 1 to port 1, and from port 2 to port 2

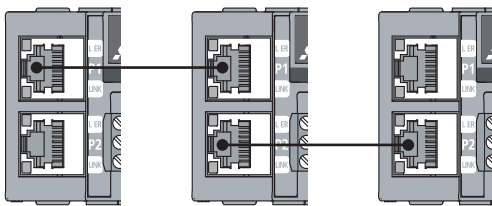

Connection from port 1 to port 2

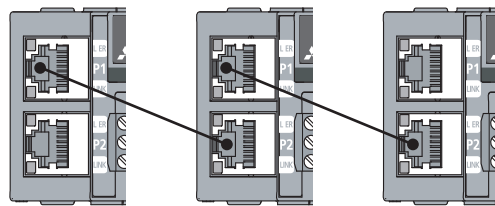

(b) Disconnecting

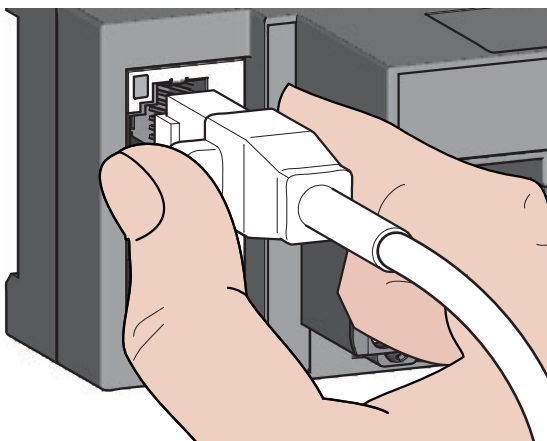

1. Power off the module.
2. With the latch of the Ethernet cable pressed, unplug the cable.

(2) Precautions

(a) Laying Ethernet cables

- The Ethernet cables must be placed in the duct or fixed by clamp. If not, dangling cable may swing or inadvertently be pulled, resulting in damage to the module or cables or malfunction due to poor contact.
- Do not touch the core of the connector of the cable or the module, and protect it from dirt and dust. If any oil from your hand, or any dirt or dust sticks to the core, it can increase transmission loss, causing data link to fail.
- Check the following:
 - Is any Ethernet cable disconnected?
 - Does any Ethernet cable short?
 - Are the connectors securely connected?

(b) Broken cable latch

Do not use Ethernet cables with broken latches. Doing so may cause the cable to unplug or malfunction.

(c) Connecting and disconnecting an Ethernet cable

Hold the connector part when connecting and disconnecting the Ethernet cable. Pulling the cable connected to the module may result in damage to the module or cable or malfunction due to poor contact.

(d) Connector to which an Ethernet cable is not connected

To prevent dust from entering the module, attach the provided connector cover.

(e) Maximum station-to-station distance for an Ethernet cable (maximum cable length)

The maximum station-to-station distance is 100m. However, the distance may be shorter depending on the operating environment of the cable. For details, contact the manufacturer of the cables used.

(f) Bending radius of an Ethernet cable

There are restrictions on the bending radius of the Ethernet cable. Check the bending radius in the specifications of the Ethernet cables used.

6.6 Wiring of Terminal Block and External Devices

(1) Tightening torque

Tighten the terminal block screws within the following specified torque range.

Tightening the screws too much may damage the module case.

Screw type	Tightening torque range
Terminal screw (M3)	0.43 to 0.57N·m
Terminal block mounting screw (M3.5)	0.68 to 0.92N·m

The following table shows applicable solderless terminals to be connected to the terminal block. For wiring, use the wire and tightening torque as specified in the table below. Use UL-listed solderless terminals, and for processing, use the tool recommended by their manufacturers. Note that a solderless terminal with an insulation sleeve cannot be used.

Solderless terminal		Wire			
Model	Applicable tightening torque	Diameter	Type	Material	Temperature rating
R1.25-3	0.43 to 0.57N·m	22 to 14 AWG	Stranded	Copper	75°C or higher
V2-MS3					
RAP2-3SL					
TGV2-3N					

(2) Removing and installing the terminal block

(a) Removal procedure

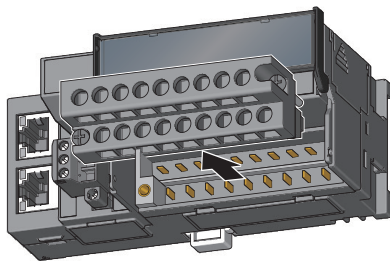
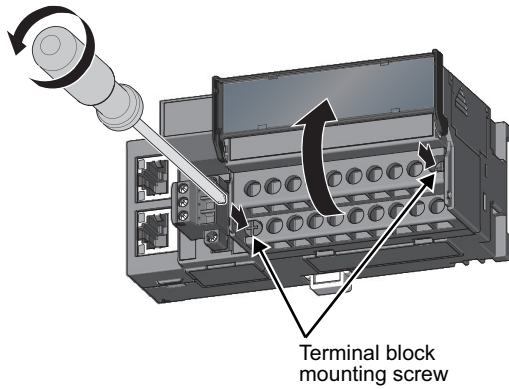

1. Open the terminal block cover and loosen the terminal block mounting screws (two points).

2. Loosening the terminal block mounting screws (two points) allows the two-piece terminal block to lift and be removed.

(b) Installation procedure

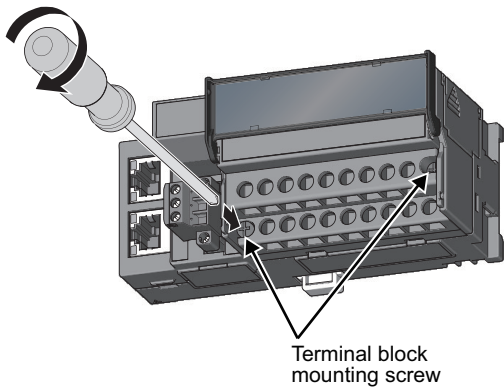
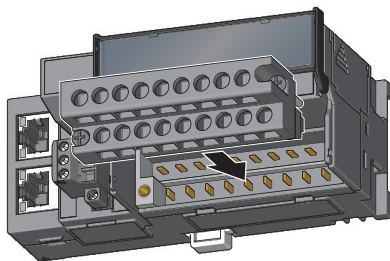

1. Open the terminal block cover to install the two-piece terminal block.

2. Tighten the terminal block mounting screws.

(3) Wiring of the terminal block and external devices

(a) Signal name

The following shows signal names of the terminal block.

1	NC	3	CH1 V+	5	CH1 I+	7	CH2 V+	9	CH2 I+	11	CH3 COM	13	SLD	15	CH4 COM	17	AG
2	NC	4	CH1 COM	6	SLD	8	CH2 COM	10	CH3 V+	12	CH3 I+	14	CH4 V+	16	CH4 I+	18	FG1

Pin number	Signal name	
1	NC	
2	NC	
3	CH1	
4		V+
5		COM
6	SLD	
7	CH2	
8		V+
9		COM
10	CH3	
11		V+
12		COM
13	SLD	
14	CH4	
15		V+
16		COM
17	AG	
18	FG1	



Do not wire the NC terminals. Incorrect wiring may cause failure or malfunction of the module.

(b) Wiring to the terminal block

The following shows wiring to the terminal block.

- For voltage input

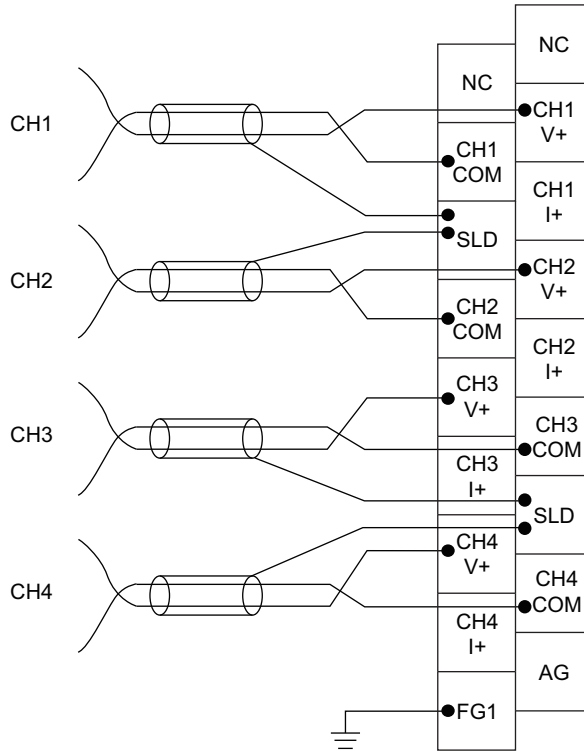

- For current input

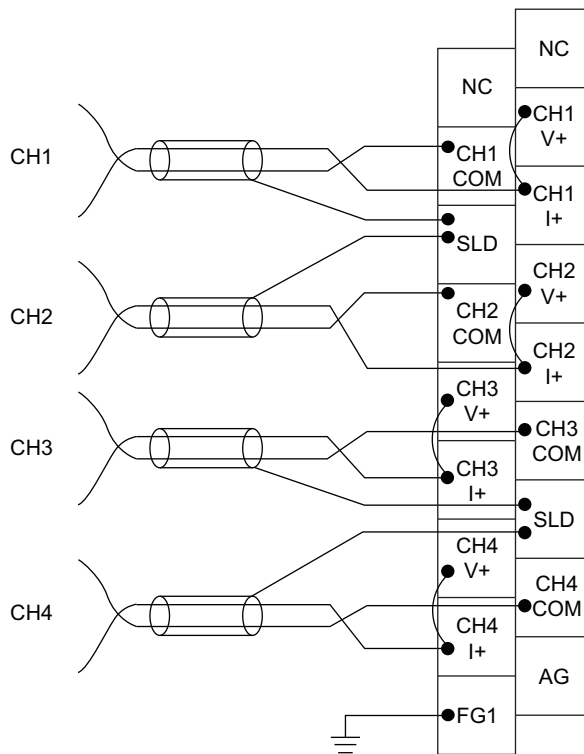

(c) Precautions for external wiring

To obtain the maximum performance from the functions of the A/D converter module and improve the system reliability, an external wiring with high durability against noise is required. Precautions for external wiring are as follows:

- Use separate cables for the AC control circuit and the external input signals of the A/D converter module to avoid the influence of the AC side surges or induction.
- Do not install cables together with the main circuit lines, high voltage lines, or power cables for equipment other than the programmable controller. Noise, surges, or induction may affect the system.
- Ground the shielded wires or shielded cables at one point on the programmable controller side. However, depending on the external noise conditions, it may be better to ground them externally.
- For the voltage input, do not exceed a range of $\pm 15V$. Doing so can cause breakdown of the elements.
- For the current input, do not exceed a range of $\pm 30mA$. Doing so can cause breakdown of the elements.

(d) External wiring

The following figure shows the external wiring.

- For voltage input

Signal source: -10 to 10V

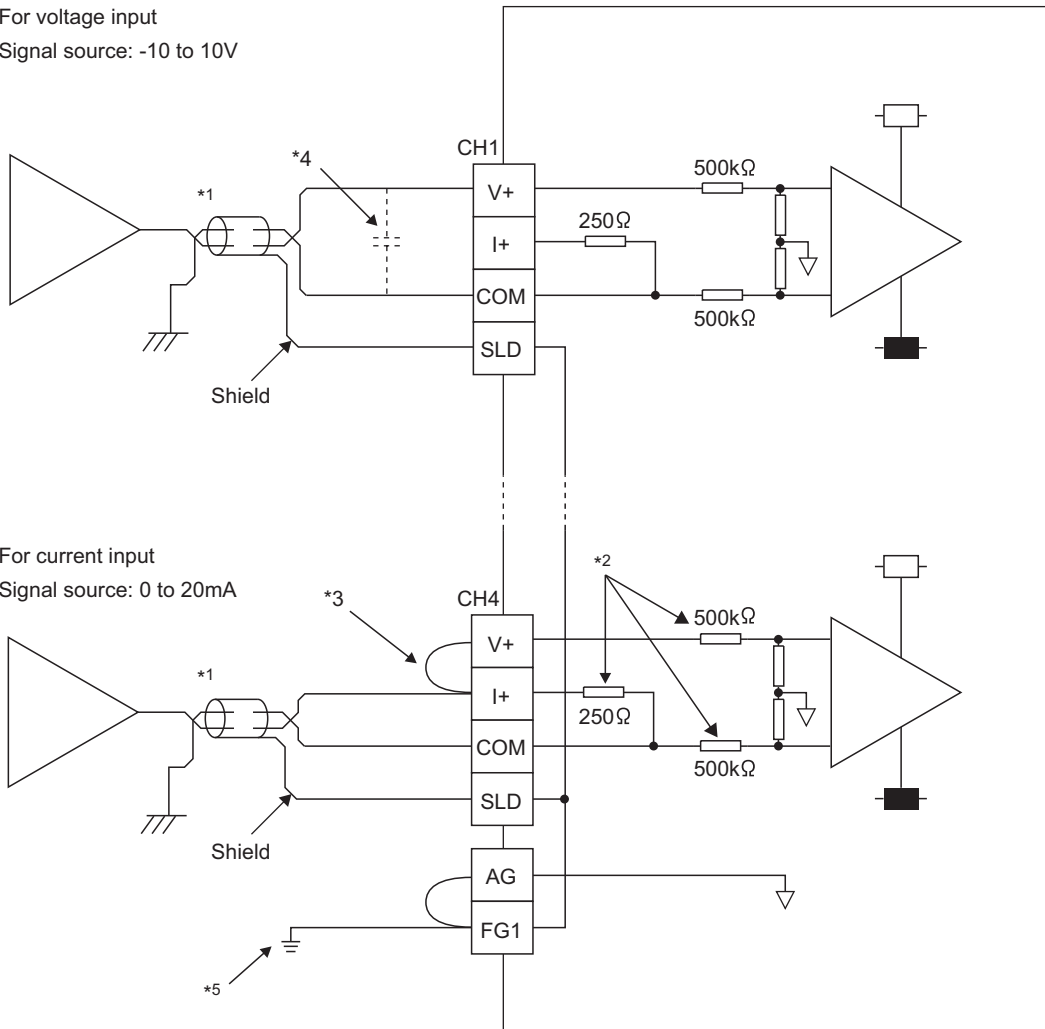

- *1 For the cable, use the 2-core shielded twisted pair cable.
- *2 This indicates the input resistance of the A/D converter module.
- *3 For the current input, always connect the terminals (V+) and (I+).
- *4 If noise or ripple is generated in the external wiring, connect a capacitor of approximately 0.1 to 0.47 μF (product with a voltage-resistance of 25V or higher) between the V+ and COM terminals.
- *5 Ground the FG1 terminal without fail. If there is much noise, it may be better to ground the AG terminal as well. If the grounding status of the AG terminal is changed after the offset/gain values are set, set the values again.

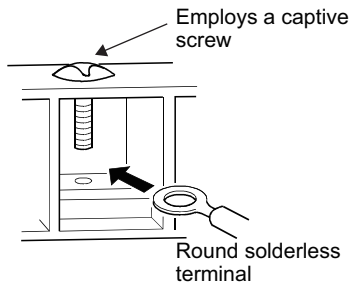
(e) Wiring method

- 1. Loosen the terminal screw. A round solderless terminal can be connected as it is.**

Point

- Avoid contact of the terminal and the screw with oil. Failure to do so may damage the screw.
- The number of the inserted applicable solderless terminals must be two or less. When inserting two applicable solderless terminals, insert them back-to-back. Otherwise the screw cannot be tightened, possibly causing damage to it.
- Tighten the terminal screw with an applicable screwdriver. Tightening with an inapplicable screwdriver may damage the screw.

CHAPTER 7 VARIOUS SETTINGS

This chapter describes how to set up various settings of the A/D converter module.

7.1 Parameter Settings

Set the parameter of this module with the network parameter written to the CPU module of the master station. For the setting procedure of the master station, refer to the following:

 User's manual for the master/local module used

Remark

- Place a checkmark in the "Set the network configuration settings in CC IE Field configuration window" box on the "MELSECNET/CC IE/Ethernet Module Configuration" window in advance.

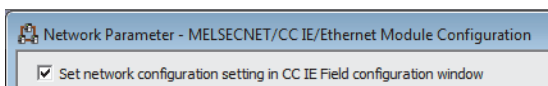

- To select the main A/D converter module in the CC IE Field Configuration window, select "NZ2GF2B-60AD4" from the "Module List" window.
- To select an extension module in the "CC IE Field Configuration" window, select the following models from the "Module List" window.

Extension module type	Name
Extension Digital Input Module	NZ2EX-16 (DI)
Extension Digital Output Module	NZ2EX-16 (DO)
Extension A/D Converter Module	NZ2EX2B-60AD4
Extension D/A Converter Module	NZ2EX2B-60DA4

- Setting fewer points of the remote I/O signal or remote register than actual points that the main A/D converter module or the extension module possesses does not cause an error. In this case, data of all the set points are subject to cyclic transmission in order.

(1) Precautions

(a) Before parameter settings

For the precautions before parameter settings, refer to the following.



 GX Works3 Operating Manual

 GX Works2 Version 1 Operating Manual (Common)

(b) Parameter settings

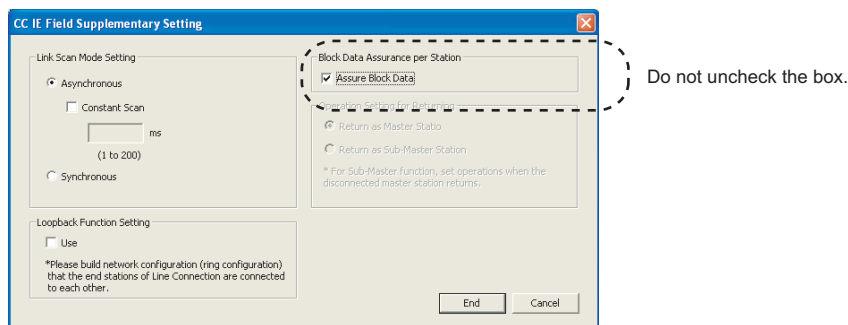
- When using the A/D converter module, always enable the block data assurance per station. When it is disabled, correct operation of the A/D converter module cannot be guaranteed. For details on the block data assurance per station, refer to the following:  User's manual for the master/local module used.



- Do not set the parameters using the CCPASET instruction in the master station. Executing the CCPASET instruction results in the module operating with block data assurance per station deactivated, where proper performance as the A/D converter module cannot be guaranteed. (The CCPASET instruction is intended to configure parameters for a master/local module. For details on the CCPASET instruction, refer to the following:  User's manual for the master/local module used.)
- When using an extension module, be sure to write the module parameters ( Page 72, Section 7.1 (2)). If the parameters of the extension module has not been written, the error code (1F30H) is stored in Latest error code (RWr0), Error flag (RXA) turns on, and the ERR. LED lights up.

(2) Setting procedure

1. Open the "CC IE Field Configuration" window.

- For the master/local module QJ71GF11-T2

Project window ⇒ [Parameter] ⇒ [Network Parameter] ⇒
[Ethernet/CC IE/MELSECNET] ⇒ **CC IE Field Configuration Setting** button

- For the master/local module LJ71GF11-T2

Project window ⇒ [Parameter] ⇒ [Network Parameter] ⇒
[Ethernet/CC IE Field] ⇒ **CC IE Field Configuration Setting** button

2. On the "CC IE Field Configuration" window, from "List of stations", select the main A/D converter module.

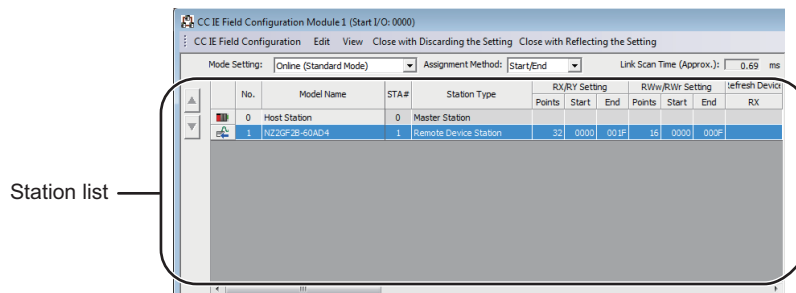

3. Open the "Parameter Processing of Slave Station" window.

[CC IE Field Configuration] ⇒ [Online] ⇒ [Parameter Processing of Slave Station]

4. Set "Method selection" to "Parameter write".

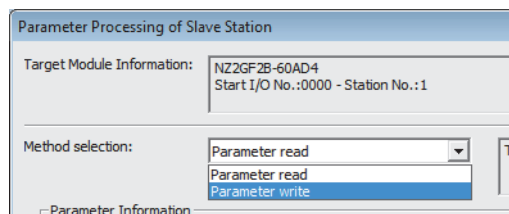

5. Double-click the item to be changed, and enter the setting value.

- Items to be selected from a pull-down list
Double-click the item to be set, and from the pull-down list that appears, select the desired item.
- Items to be entered via text box
Double-click the item to be set, and enter the desired value.

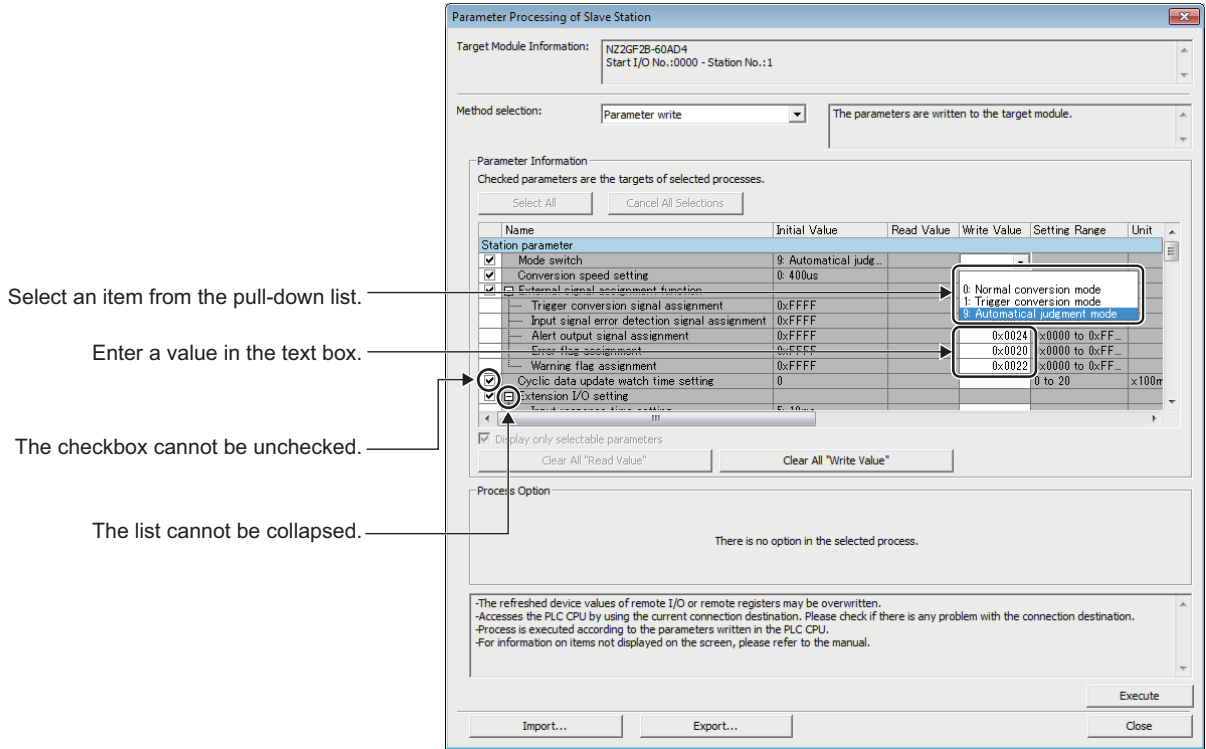

- Station parameter

Setting item		Reference
Mode switch		Page 87, Section 8.2
Conversion speed setting		Page 90, Section 8.5
External signal assignment function	Trigger conversion signal assignment	Page 147, Section 8.18.1 (2)
	Input signal error detection signal assignment	
	Alert output signal assignment	
	Error flag assignment	
	Warning flag assignment	
Cyclic data update watch time setting		Page 146, Section 8.18.1
Extension I/O setting	Input response time setting	
	Digital output HOLD/CLEAR setting	

- Basic module parameter

Setting item		Reference
A/D conversion enable/disable setting	CH1 A/D conversion enable/disable setting	Page 90, Section 8.4
	CH2 A/D conversion enable/disable setting	
	CH3 A/D conversion enable/disable setting	
	CH4 A/D conversion enable/disable setting	
Range setting	CH1 Range setting	Page 100, Section 8.7
	CH2 Range setting	
	CH3 Range setting	
	CH4 Range setting	

	Setting item	Reference
Averaging process setting	CH1 Averaging process setting	Page 96, Section 8.6
	CH1 Time average/Count average/Moving average	
	CH2 Averaging process setting	
	CH2 Time average/Count average/Moving average	
	CH3 Averaging process setting	
	CH3 Time average/Count average/Moving average	
	CH4 Averaging process setting	
	CH4 Time average/Count average/Moving average	
Input signal error detection function	CH1 Input signal error detection setting	Page 102, Section 8.9
	CH2 Input signal error detection setting	
	CH3 Input signal error detection setting	
	CH4 Input signal error detection setting	
Alert output function	CH1 Alert output setting	Page 106, Section 8.10
	CH1 Process alarm upper upper limit value	
	CH1 Process alarm upper lower limit value	
	CH1 Process alarm lower upper limit value	
	CH1 Process alarm lower lower limit value	
	CH2 Alert output setting	
	CH2 Process alarm upper upper limit value	
	CH2 Process alarm upper lower limit value	
	CH2 Process alarm lower upper limit value	
	CH2 Process alarm lower lower limit value	
	CH3 Alert output setting	
	CH3 Process alarm upper upper limit value	
	CH3 Process alarm upper lower limit value	
	CH3 Process alarm lower upper limit value	
	CH3 Process alarm lower lower limit value	
	CH4 Alert output setting	
CH4 Process alarm upper upper limit value		
CH4 Process alarm upper lower limit value		
CH4 Process alarm lower upper limit value		
CH4 Process alarm lower lower limit value		
Digital clipping function	CH1 Digital clipping enable/disable setting	Page 118, Section 8.13
	CH2 Digital clipping enable/disable setting	
	CH3 Digital clipping enable/disable setting	
	CH4 Digital clipping enable/disable setting	
Scaling function	CH1 Scaling enable/disable setting	Page 109, Section 8.11
	CH1 Scaling upper limit value	
	CH1 Scaling lower limit value	
	CH2 Scaling enable/disable setting	
	CH2 Scaling upper limit value	
	CH2 Scaling lower limit value	
	CH3 Scaling enable/disable setting	
	CH3 Scaling upper limit value	
	CH3 Scaling lower limit value	
	CH4 Scaling enable/disable setting	
	CH4 Scaling upper limit value	
	CH4 Scaling lower limit value	

• Ext. module 1_Module parameter

Setting item		Reference
Ext. module 1_A/D conversion enable/disable setting	Ext. module 1_CH1 A/D conversion enable/disable setting	Page 90, Section 8.4
	Ext. module 1_CH2 A/D conversion enable/disable setting	
	Ext. module 1_CH3 A/D conversion enable/disable setting	
	Ext. module 1_CH4 A/D conversion enable/disable setting	
Ext. module 1_Range setting	Ext. module 1_CH1 Range setting	Page 100, Section 8.7
	Ext. module 1_CH2 Range setting	
	Ext. module 1_CH3 Range setting	
	Ext. module 1_CH4 Range setting	
Ext. module 1_Average processing setting	Ext. module 1_CH1 Averaging process setting	Page 96, Section 8.6
	Ext. module 1_CH1 Time average/Count average/Moving average	
	Ext. module 1_CH2 Averaging process setting	
	Ext. module 1_CH2 Time average/Count average/Moving average	
	Ext. module 1_CH3 Averaging process setting	
	Ext. module 1_CH3 Time average/Count average/Moving average	
	Ext. module 1_CH4 Averaging process setting	
Ext. module 1_Input signal error detection function	Ext. module 1_CH1 Input signal error detection function setting	Page 102, Section 8.9
	Ext. module 1_CH2 Input signal error detection function setting	
	Ext. module 1_CH3 Input signal error detection function setting	
	Ext. module 1_CH4 Input signal error detection function setting	
Ext. module 1_Alert output function	Ext. module 1_CH1 Alert output setting	Page 106, Section 8.10
	Ext. module 1_CH1 Process alarm upper upper limit value	
	Ext. module 1_CH1 Process alarm upper lower limit value	
	Ext. module 1_CH1 Process alarm lower upper limit value	
	Ext. module 1_CH1 Process alarm lower lower limit value	
	Ext. module 1_CH2 Alert output setting	
	Ext. module 1_CH2 Process alarm upper upper limit value	
	Ext. module 1_CH2 Process alarm upper lower limit value	
	Ext. module 1_CH2 Process alarm lower upper limit value	
	Ext. module 1_CH2 Process alarm lower lower limit value	
	Ext. module 1_CH3 Alert output setting	
	Ext. module 1_CH3 Process alarm upper upper limit value	
	Ext. module 1_CH3 Process alarm upper lower limit value	
	Ext. module 1_CH3 Process alarm lower upper limit value	
	Ext. module 1_CH3 Process alarm lower lower limit value	
	Ext. module 1_CH4 Alert output setting	
	Ext. module 1_CH4 Process alarm upper upper limit value	
Ext. module 1_CH4 Process alarm upper lower limit value		
Ext. module 1_CH4 Process alarm lower upper limit value		
Ext. module 1_CH4 Process alarm lower lower limit value		
Ext. module 1_Digital clipping function	Ext. module 1_CH1 Digital clipping enable/disable setting	Page 118, Section 8.13
	Ext. module 1_CH2 Digital clipping enable/disable setting	
	Ext. module 1_CH3 Digital clipping enable/disable setting	
	Ext. module 1_CH4 Digital clipping enable/disable setting	

	Setting item	Reference
Ext. module 1_Scaling function	Ext. module 1_CH1 Scaling enable/disable setting	Page 109, Section 8.11
	Ext. module 1_CH1 Scaling upper limit value	
	Ext. module 1_CH1 Scaling lower limit value	
	Ext. module 1_CH2 Scaling enable/disable setting	
	Ext. module 1_CH2 Scaling upper limit value	
	Ext. module 1_CH2 Scaling lower limit value	
	Ext. module 1_CH3 Scaling enable/disable setting	
	Ext. module 1_CH3 Scaling upper limit value	
	Ext. module 1_CH3 Scaling lower limit value	
	Ext. module 1_CH4 Scaling enable/disable setting	
	Ext. module 1_CH4 Scaling upper limit value	
	Ext. module 1_CH4 Scaling lower limit value	

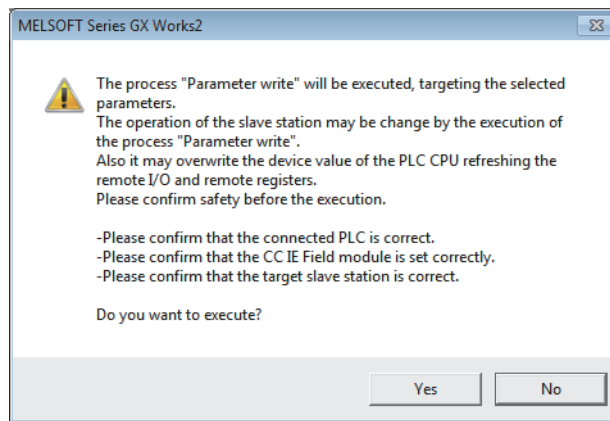

6. Click  button to open the following window.



7. Click  button.

8. The parameters are written to the A/D converter module.

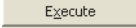
Point

- When using an extension module, also set the parameters of the extension module. For the parameters of the extension module, refer to the following:
 Manual of the extension module used
- Set all the items for the parameter. If any blank exists, the parameters cannot be written to the A/D converter module.
- To read the parameter from the A/D converter module, set "Method selection" to "Parameter read" and click  button.
- The parameters are checked when they are written to the A/D converter module. If the following message is displayed during the writing, take corrective action for the error code in < >. For details on the error codes, refer to the list of error codes ( Page 173, Section 11.2) and the user's manual for the master/local module used.

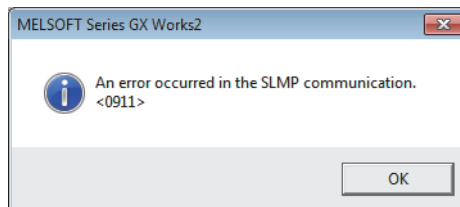

7.2 How to Change the Parameters

This section describes the procedures to change the parameters.

The precautions to take when changing the parameters are the same as the following:

- Precautions (☞ Page 71, Section 7.1 (1))

7.2.1 Changing the network configuration

To change the network configuration reusing the already created project, set the parameters in the following steps:

1. Turn off the module power supply from on.
2. Connect the modules again according to the desired network configuration.
3. Turn on the module power supply from off.
4. Open the "CC IE Field Configuration" window.
 - For the master/local module QJ71GF11-T2
 - ☞ Project window ⇒ [Parameter] ⇒ [Network Parameter] ⇒ [Ethernet/CC IE/MELSECNET] ⇒ **CC IE Field Configuration Setting** button
 - For the master/local module LJ71GF11-T2
 - ☞ Project window ⇒ [Parameter] ⇒ [Network Parameter] ⇒ [Ethernet/CC IE Field] ⇒ **CC IE Field Configuration Setting** button
5. Set up the slave station with drag and drop, and enter the station number for the slave station. Change values as necessary.

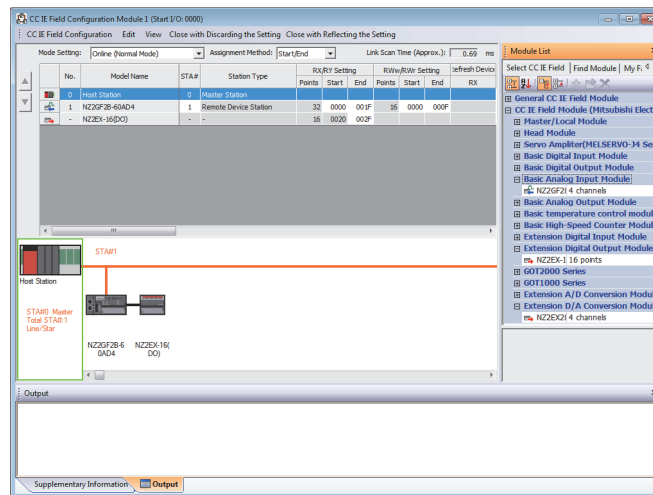

- On the "CC IE Field Configuration" window, from "List of stations", select the main A/D converter module.

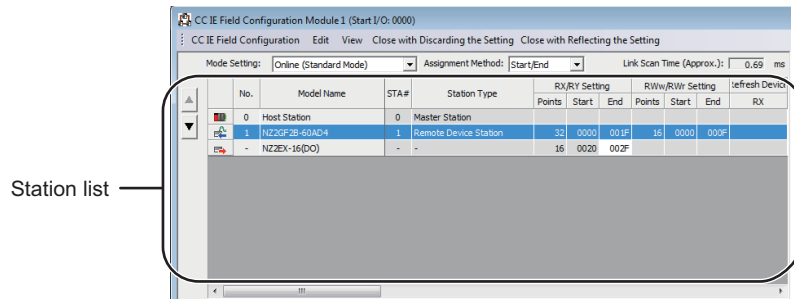

- Open the "Parameter Processing of Slave Station" window.

[CC IE Field Configuration] ⇒ [Online] ⇒ [Parameter Processing of Slave Station]

- Set "Method selection" to "Parameter read".

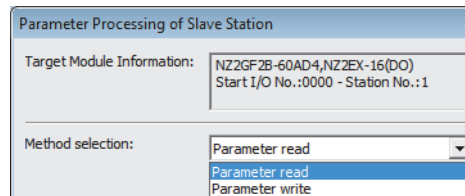

- Click  button to open the following window.

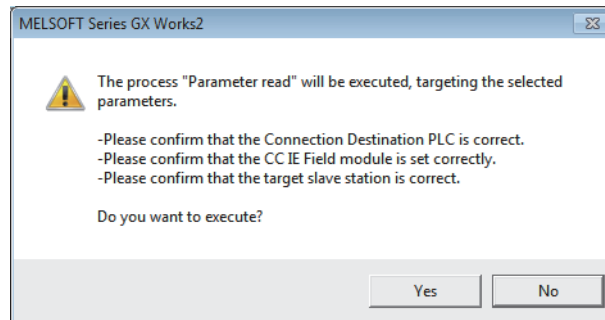

- Click  button.

- The parameters are read from the A/D converter module.

Name	Initial Value	Read Value	Write Value	Setting Range
Station parameter				
<input checked="" type="checkbox"/> Mode switch	9: Automatical jud...	1: Trigger conve...		
<input checked="" type="checkbox"/> Conversion speed setting	0: 400us	0: 400us		
<input checked="" type="checkbox"/> External signal assignment function				
..... Trigger conversion signal assignment	0xFFFF	0xFFFF		0x0000 to 0xFF...
..... Input signal error detection signal assignment	0xFFFF	0xFFFF		0x0000 to 0xFF...
..... Alert output signal assignment	0xFFFF	0xFFFF		0x0000 to 0xFF...
..... Error flag assignment	0xFFFF	0xFFFF		0x0000 to 0xFF...
..... Warning flag assignment	0xFFFF	0xFFFF		0x0000 to 0xFF...
<input checked="" type="checkbox"/> Cyclic data update watch time setting	0	0		0 to 20
<input checked="" type="checkbox"/> Extension I/O setting				

12. Set "Method selection" to "Parameter write".

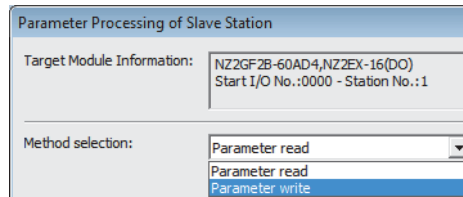



13. Set "Write Value". Follow the next steps to set the value:

- Click the title cell of "Read Value" to select all the items and copy them.
- Click the title cell of "Write Value" to select all the items and paste the copy.
- Select the items to be changed, and set new values.

Name	Initial Value	Read Value	Write Value	Setting Range
Station parameter				
<input checked="" type="checkbox"/> Mode switch	9: Automatical j...	9: Automatical j...	9: Automatical j...	
<input checked="" type="checkbox"/> Conversion speed setting	0: 400us	0: 400us	0: 400us	
<input checked="" type="checkbox"/> External signal assignment function				
..... Trigger conversion signal assignment	0xFFFF	0xFFFF	0xFFFF	0x0000 to 0xFF...
..... Input signal error detection signal assignment	0xFFFF	0xFFFF	0xFFFF	0x0000 to 0xFF...
..... Alert output signal assignment	0xFFFF	0xFFFF	0xFFFF	0x0000 to 0xFF...
..... Error flag assignment	0xFFFF	0xFFFF	0xFFFF	0x0000 to 0xFF...
..... Warning flag assignment	0xFFFF	0xFFFF	0xFFFF	0x0000 to 0xFF...
<input checked="" type="checkbox"/> Cyclic data update watch time setting	0	0	0	0 to 20
<input checked="" type="checkbox"/> Extension I/O setting				

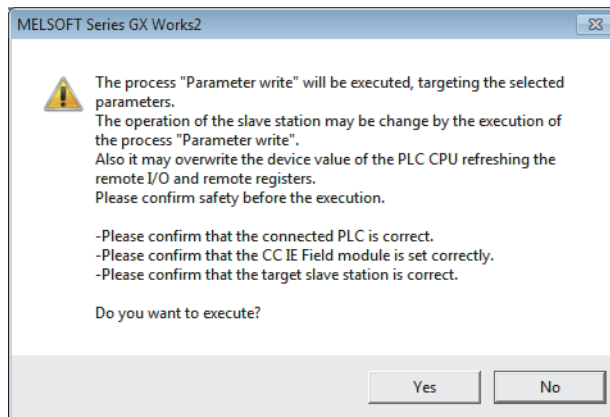
14. Click  button to open the following window.





15. Click  button.

16. The parameters are written to the A/D converter module.

Setting up the module parameters of the slave station is now complete.

17. Close the "CC IE Field Configuration" window.

 [CC IE Field Configuration] ⇒ [Close with Reflecting the Setting]

18. Click  button to open the refresh parameter setting window.

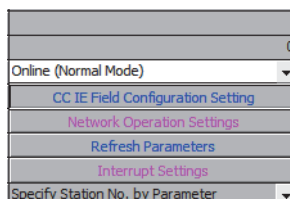

19. Set up the refresh parameters. Change values as necessary.

Assignment Method
 Points/Start
 Start/End

	Link Side					PLC Side			
	Dev. Name	Points	Start	End		Dev. Name	Points	Start	End
Transfer SB	SB	512	0000	01FF	↔	SB	512	0000	01FF
Transfer SW	SW	512	0000	01FF	↔	SW	512	0000	01FF
Transfer 1	RX	64	0000	003F	↔	X	64	1000	103F
Transfer 2	RY	64	0000	003F	↔	Y	64	1000	103F
Transfer 3	RWw	16	0000	000F	↔	W	16	001000	00100F
Transfer 4	RWr	16	0000	000F	↔	W	16	001100	00110F
Transfer 5					↔				
Transfer 6					↔				
Transfer 7					↔				
Transfer 8					↔				

20. Write the set parameters to the CPU module of the master station, and reset the CPU module.

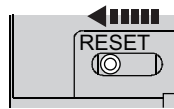

21. Put the CPU module of the master station into RUN.

Setting up the network configuration is now complete.

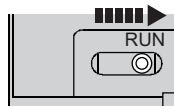

7.2.2 Changing the parameters without changing the network configuration

To change only the module parameters of the already set-up slave station without changing the network configuration, take the following steps:

1. Open the "CC IE Field Configuration" window.
 - For the master/local module QJ71GF11-T2
 - ☞ Project window ⇒ [Parameter] ⇒ [Network Parameter] ⇒ [Ethernet/CC IE/MELSECNET] ⇒ **CC IE Field Configuration Setting** button
 - For the master/local module LJ71GF11-T2
 - ☞ Project window ⇒ [Parameter] ⇒ [Network Parameter] ⇒ [Ethernet/CC IE Field] ⇒ **CC IE Field Configuration Setting** button
2. On the "CC IE Field Configuration" window, from "List of stations", select the A/D converter module.

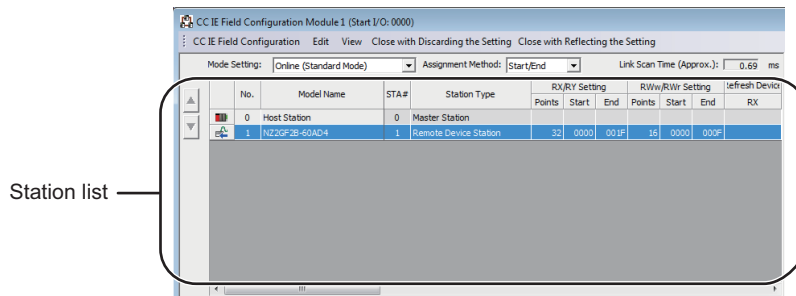

3. Open the "Parameter Processing of Slave Station" window.
 - ☞ [CC IE Field Configuration] ⇒ [Online] ⇒ [Parameter Processing of Slave Station]
4. Set "Method selection" to "Parameter read".

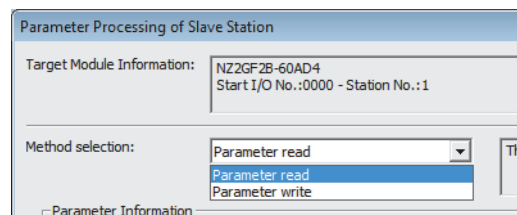

5. Click  button to open the following window.

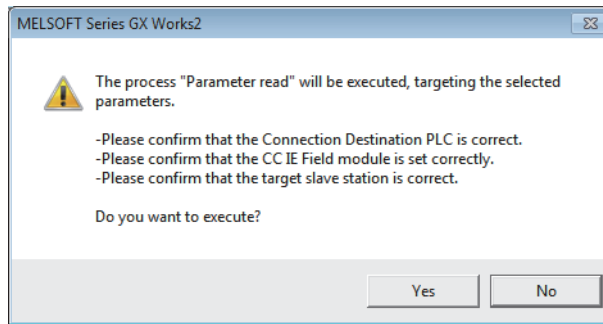

6. Click  button.
 7. The parameters are read from the A/D converter module.

Name	Initial Value	Read Value	Write Value	Setting Range
Station parameter				
<input checked="" type="checkbox"/> Mode switch	9: Automatical jud...	1: Trigger conver...		
<input checked="" type="checkbox"/> Conversion speed setting	0: 400us	0: 400us		
<input checked="" type="checkbox"/> External signal assignment function				
..... Trigger conversion signal assignment	0xFFFF	0xFFFF		0x0000 to 0xFF...
..... Input signal error detection signal assignment	0xFFFF	0xFFFF		0x0000 to 0xFF...
..... Alert output signal assignment	0xFFFF	0xFFFF		0x0000 to 0xFF...
..... Error flag assignment	0xFFFF	0xFFFF		0x0000 to 0xFF...
..... Warning flag assignment	0xFFFF	0xFFFF		0x0000 to 0xFF...
<input checked="" type="checkbox"/> Cyclic data update watch time setting	0	0		0 to 20
<input checked="" type="checkbox"/> Extension I/O setting				

8. Set "Method selection" to "Parameter write".

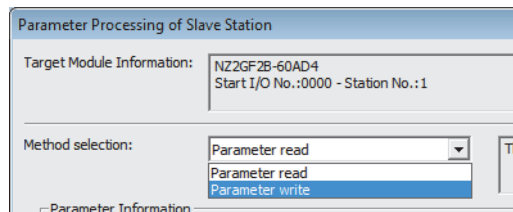



9. Set "Write Value". Follow the next steps to set the value:

- Click the title cell of "Read Value" to select all the items and copy them.
- Click the title cell of "Write Value" to select all the items and paste the copy.
- Select the items to be changed, and set new values.

Name	Initial Value	Read Value	Write Value	Setting Range
Station parameter				
<input checked="" type="checkbox"/> Mode switch	9: Automatical j...	1: Trigger conv...	9: Automatical ju...	
<input checked="" type="checkbox"/> Conversion speed setting	0: 400us	0: 400us	0: 400us	
<input checked="" type="checkbox"/> External signal assignment function				
..... Trigger conversion signal assignment	0xFFFF	0xFFFF	0xFFFF	0x0000 to 0xFF...
..... Input signal error detection signal assignment	0xFFFF	0xFFFF	0xFFFF	0x0000 to 0xFF...
..... Alert output signal assignment	0xFFFF	0xFFFF	0xFFFF	0x0000 to 0xFF...
..... Error flag assignment	0xFFFF	0xFFFF	0xFFFF	0x0000 to 0xFF...
..... Warning flag assignment	0xFFFF	0xFFFF	0xFFFF	0x0000 to 0xFF...
<input checked="" type="checkbox"/> Cyclic data update watch time setting	0	0	0	0 to 20
<input checked="" type="checkbox"/> Extension I/O setting				

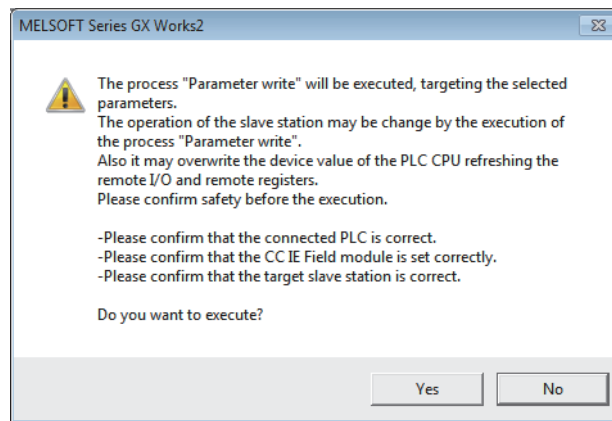
10. Click  button to open the following window.



11. Click  button.

12. The parameters are written to the A/D converter module.

Setting the module parameters of the slave station is complete.

7.3 Offset/Gain Setting

If the user range is necessary, set up the offset/gain setting by following the instructions as illustrated below.
 Note that using the factory default range does not require the offset/gain setting.

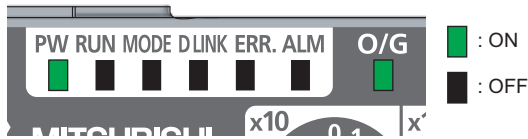
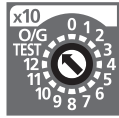

1. Turn off the module power supply.
2. Set x10 of the station number setting switch to O/G.

3. Turn on the module power supply and check that the LEDs are in the following state:
 RUN LED: Off
 O/G LED: On

4. Select the setting target using SET/SEL button.

[User range setting 1 (-10 to 10V)]

	V	I	ch1	2	3	4	OFFSET	GAIN
CH1: Offset	■	■	■	■	■	■	■	■
CH1: Gain	■	■	■	■	■	■	■	■
CH2: Offset	■	■	■	■	■	■	■	■
CH2: Gain	■	■	■	■	■	■	■	■
CH3: Offset	■	■	■	■	■	■	■	■
CH3: Gain	■	■	■	■	■	■	■	■
CH4: Offset	■	■	■	■	■	■	■	■
CH4: Gain	■	■	■	■	■	■	■	■

[User range setting 2 (-5 to 5V, -20 to 20mA)]

	V	I	ch1	2	3	4	OFFSET	GAIN
CH1: Offset	■	■	■	■	■	■	■	■
CH1: Gain	■	■	■	■	■	■	■	■
CH2: Offset	■	■	■	■	■	■	■	■
CH2: Gain	■	■	■	■	■	■	■	■
CH3: Offset	■	■	■	■	■	■	■	■
CH3: Gain	■	■	■	■	■	■	■	■
CH4: Offset	■	■	■	■	■	■	■	■
CH4: Gain	■	■	■	■	■	■	■	■

▲ button ▼ button

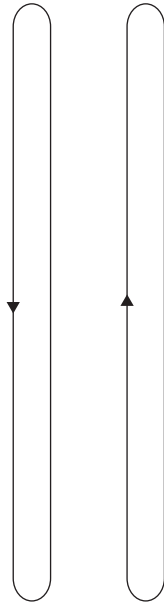

5. Apply the offset value or gain value to the selected channel for one second or more.

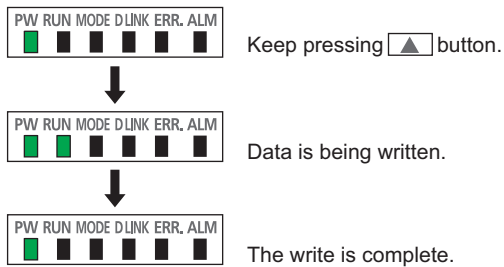

6. Keep pressing ▲ button until the RUN LED lights up.

Once the RUN LED lights up, release ▲ button. While the RUN LED lights up, the offset value or gain value is being written to the non-volatile memory.

After the writing, the RUN LED lights out.

After checking that the RUN LED lights out, go to the next step.

7. To set up another channel, go back to step 4.

8. After setting all the channels to be used, turn off the module power supply.

Point

- Set up the offset value and the gain value under actual use conditions. Connection to the CC-Link IE Field Network is not necessary.
- Set up the offset/gain setting in the range satisfying the following condition. If the range is exceeded, the maximum resolution and accuracy may not fall within the range described in the performance specifications.
 - I/O Conversion Characteristics of A/D Conversion (Page 230, Appendix 4)
- Set values are held and available even after turning off the module power supply because a offset value and a gain value are written into the non-volatile memory in the main A/D converter module.
- Set up the offset/gain setting so that the offset value is smaller than the gain value. With Range setting (address: 0103H) set to User range setting 1 or User range setting 2, the main A/D converter module performs a check on the offset/gain set values when Initial data setting request flag (RY9) is turned on from off. For invalid condition (offset value \geq gain value), this check results in the error code (040□H) being stored into Latest error code (RWr0), Error flag (RXA) turning on, and the ERR. LED lighting up.
- The extension A/D converter module does not support user range. Therefore, the offset/gain setting cannot be set up for the extension A/D converter module.

CHAPTER 8 FUNCTIONS

This chapter describes the details of the functions available in the A/D converter module, and the setting procedures for those functions.

For details on remote I/O signals, remote registers, and remote buffer memory, refer to the following:

- Details of Remote I/O Signals (☞ Page 190, Appendix 1)
- Details of Remote Registers (☞ Page 202, Appendix 2)
- Details of Remote Buffer Memory (☞ Page 206, Appendix 3)

8.1 Mode Shift at Power-On

At power-on, the main A/D converter module enters any of the following modes:

- Offset/gain setting mode
- Unit test mode
- Normal mode
- Trigger conversion mode
- Synchronous communication mode

The conditions of shift to these modes are shown below:

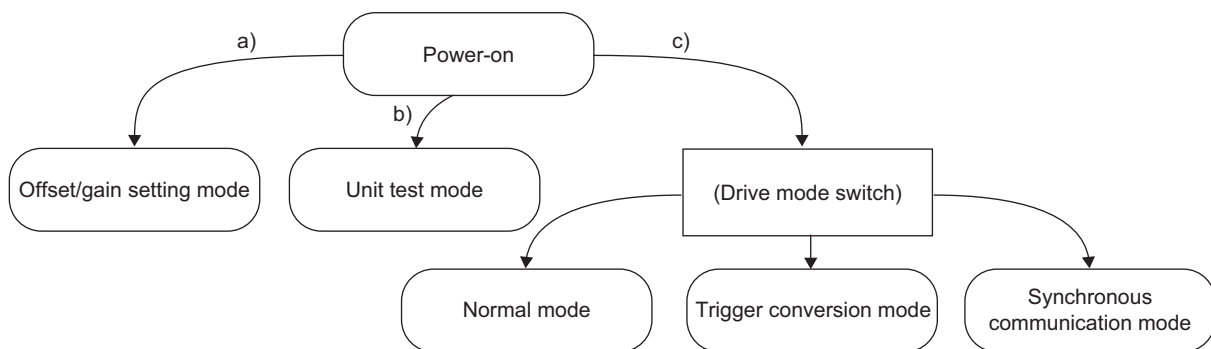

Mark	Mode	Condition
a)	Offset/gain setting mode	If x10 of the station number setting switch is set to O/G, the mode shifts to offset/gain setting mode. For details, refer to the following: • Offset/Gain Setting (☞ Page 84, Section 7.3)
b)	Unit test mode	If x10 of the station number setting switch is set to TEST and x1 of the switch is set to 0, the mode shifts to the unit test mode. For details, refer to the following: • Unit Test (☞ Page 186, Section 11.5)
c)	(Drive mode switch)	With the station number setting switch set to 1 to 120, the module enters each drive mode according to the setting of Mode switch (address: 0000H). For details, refer to the following: • Drive Mode Switch (☞ Page 87, Section 8.2)

8.2 Drive Mode Switch

The A/D converter module operates in the following modes: normal mode, trigger conversion mode, and synchronous communication mode.

The following table lists the types of drive mode and their operation.

Type of drive mode	Operation
Normal mode	A/D conversion is performed based on the internal clock of the main A/D converter module.
Trigger conversion mode	A/D conversion is performed at the time of turning on Trigger conversion request (RY19, RY29) from off.
Synchronous communication mode	A/D conversion is performed with a synchronization period of the master station that supports the CC-Link IE Field Network synchronous communication function.

The drive mode can be selected by setting Mode switch (address: 0000H).

(1) Setting procedure

1. Set "Method selection" to "Parameter write".

 "CC IE Field Configuration" window ⇒ Select a main A/D converter module from "List of stations" ⇒ [CC IE Field Configuration] ⇒ [Online] ⇒ [Parameter Processing of Slave Station]

2. In "Station parameter", set "Mode switch" to either "0: Normal conversion mode", "1: Trigger conversion mode", or "9: Automatical judgment mode".

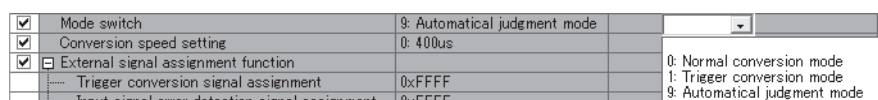

The following table lists the setting value of "Mode switch" and the drive mode.

Setting value of "Mode switch"	Drive mode
"0: Normal conversion mode"	The A/D converter module operates in normal mode.
"1: Trigger conversion mode"	The A/D converter module operates in trigger conversion mode.
"9: Automatical judgment mode"	The drive mode is automatically set according to the type of the module that operates as the master station of the A/D converter module.*1

*1 The drive mode varies depending on the module of the master station as shown below.

Master station	Setting of the master station*2	Drive mode when "Mode switch" is set to "9: Automatical judgment mode"
Master/local module (CC-Link IE Field Network synchronous communication function not supported)	—	Normal mode
Master/local module (CC-Link IE Field Network synchronous communication function supported)	Setting the CC-Link IE Field Network synchronous communication function to be disabled	Normal mode
	Setting the CC-Link IE Field Network synchronous communication function to be enabled	Synchronous communication mode
Simple motion module	First five digits of the serial number are 15091 or earlier.	Normal mode
	First five digits of the serial number are 15092 or later.	Synchronous communication mode

*2 For how to set the master station, refer to the MELSEC iQ-R Inter-Module Synchronization Function Reference Manual.

3. Click button to write the parameters to the A/D converter module.

4. Check that "0920H" is stored in Latest warning code (RWr1).

 [Online] ⇒ [Monitor] ⇒ [Device/Buffer Memory Batch]

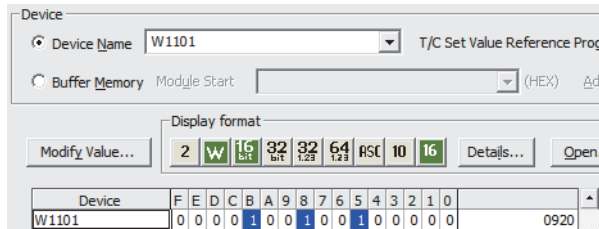

5. The A/D converter module starts operating in the set drive mode by turning off and on the module power supply or performing remote reset.

Point

- For normal conversion mode operation of the A/D converter module connected to a master station that supports the CC-Link IE Field Network synchronous communication function, set to "0: Normal conversion mode".
- In the MELSEC iQ-R series master station, setting each slave station to Synchronous or Asynchronous allows their operation (synchronous communication mode or normal mode) to be managed and configured at a time by the master station. Note, however, that settings for the extension modules have no effect. Their operation follows the settings of the main module connected.

Detect Now											
Mode Setting:		Assignment Method:		Link Scan Time (Approx.):							
Online (Standard Mode)		Start/End		0.76 ms							
No.	Model Name	STA#	Station Type	RX/RV Setting			RWw/RWr Setting			Reserved/Error Invalid Station	Network Synchronous Communication
				Points	Start	End	Points	Start	End		
0	Host Station	0	Master Station								
1	NZ2GF2B-60AD4	1	Remote Device Station	32	0000	001F	15	0000	000F	No Setting	Synchronous
-	NZ2EX2B-60AD4	-	-	16	0020	002F	16	0010	001F		Asynchronous
2	NZ2GF2B-60DA4	2	Remote Device Station	32	0000	001F	16	0000	000F	No Setting	Synchronous
-	NZ2EX2B-60AD4	-	-	16	0020	002F	16	0010	001F		Asynchronous
3	NZ2GF2B1-16D	3	Remote Device Station	16	0000	000F	20	0000	0013	No Setting	Asynchronous

(2) Drive mode of extension modules

When an extension analog module is connected to a main analog module, the extension analog module operates in the drive mode corresponding to that of the main analog module.

The following table lists the details.

Main analog module	Extension analog module	Drive mode of main analog module	Drive mode of extension analog module
Main A/D converter module	Extension A/D converter module	Normal mode	
		Trigger conversion mode	
		Synchronous communication mode	
	Extension D/A converter module	Normal mode	
		Trigger conversion mode	Trigger output mode
		Synchronous communication mode	
Main D/A converter module	Extension A/D converter module	Normal mode	
		Trigger output mode	Trigger conversion mode
		Synchronous communication mode	
	Extension D/A converter module	Normal mode	
		Trigger output mode	
		Synchronous communication mode	

8.3 Each Function in the Sequence

An analog input value and digital operation value are processed by the functions in the order shown below. If multiple functions are enabled, the output of the first-processed function is used as the input of the next function.

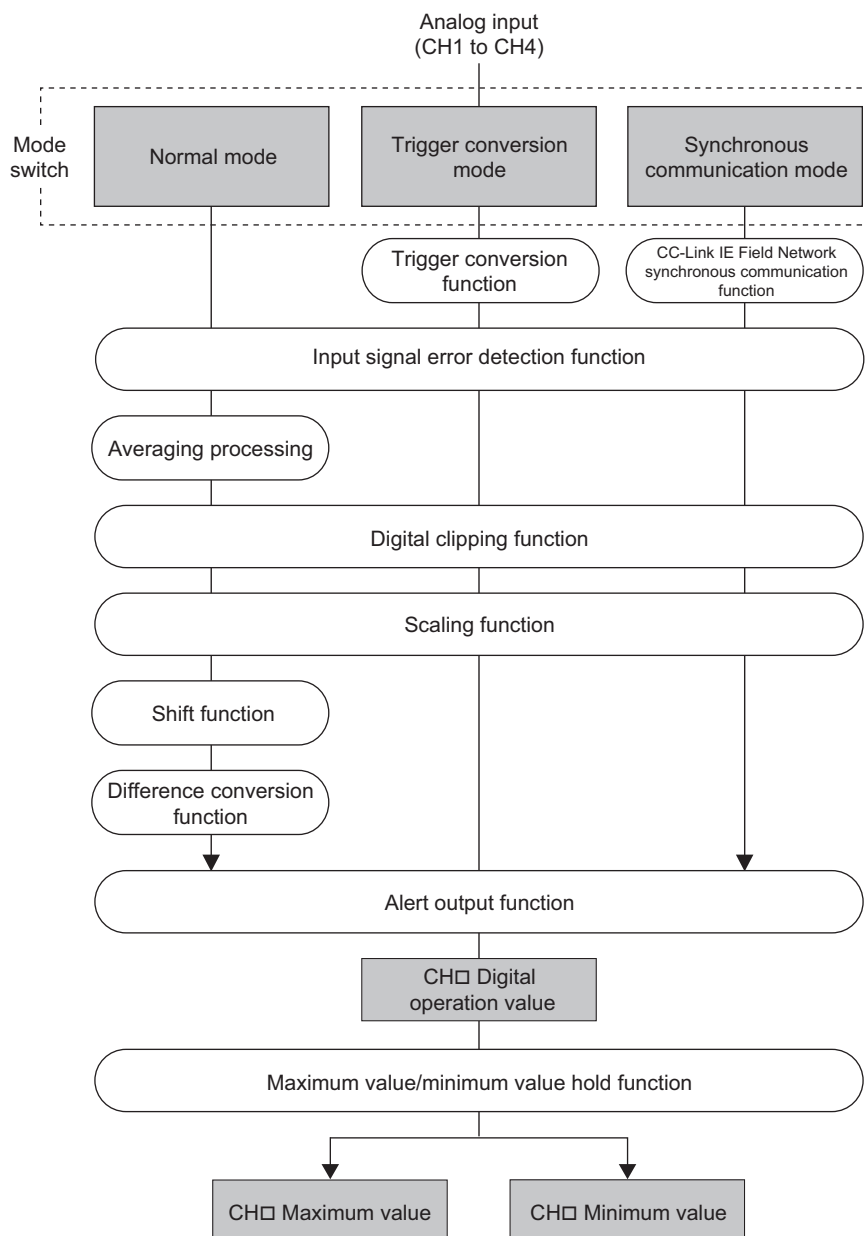

(1) Digital operation value

Digital values after sampling processing or averaging processing have been performed are called digital output values.

The values obtained by operating the digital output value using the digital clipping function, scaling function, shift function, or difference conversion function are stored.

(2) Maximum and minimum values

The maximum and minimum values of the digital operation values are stored.

8.4 A/D Conversion Enable/Disable Function

This function allows A/D conversion to be enabled or disabled for each channel.
Disabling the A/D conversion for unused channels reduces the conversion cycles.

(1) Setting procedure

The setting procedure for the main A/D converter module is as follows:

1. Set "Method selection" to "Parameter write".

 "CC IE Field Configuration" window ⇒ Select a main A/D converter module from "List of stations" ⇒ [CC IE Field Configuration] ⇒ [Online] ⇒ [Parameter Processing of Slave Station]

2. In "Basic module parameter", set "CH□ A/D conversion enable/disable setting" to either "0: Enable" or "1: Disable".

<input checked="" type="checkbox"/>	A/D conversion enable/disable setting			
<input type="checkbox"/>	CH1 A/D conversion enable/disable setting	0: Enable		
<input type="checkbox"/>	CH2 A/D conversion enable/disable setting	0: Enable		
<input type="checkbox"/>	CH3 A/D conversion enable/disable setting	0: Enable		
<input type="checkbox"/>	CH4 A/D conversion enable/disable setting	0: Enable		

Point

For the extension A/D converter module, go to "Ext. module 1_Module parameter", and make the setting of "Ext. module 1_CH□ A/D conversion enable/disable setting".

8.5 Conversion Speed Switch Function

Conversion speed of the main A/D converter module can be selected from the following three rates:

- 100μs
- 400μs
- 1ms

(1) Setting procedure

1. Set "Method selection" to "Parameter write".

 "CC IE Field Configuration" window ⇒ Select a main A/D converter module from "List of stations" ⇒ [CC IE Field Configuration] ⇒ [Online] ⇒ [Parameter Processing of Slave Station]

2. In "Station parameter", from "Conversion speed setting", select the conversion speed.

<input checked="" type="checkbox"/>	Conversion speed setting	0: 400us		
<input checked="" type="checkbox"/>	External signal assignment function			
<input type="checkbox"/>	Trigger conversion signal assignment	0xFFFF		0: 400us
<input type="checkbox"/>	Input signal error detection signal assignment	0xFFFF		1: 1ms
<input type="checkbox"/>	Alert output signal assignment	0xFFFF		2: 100us

8.5.1 Conversion speed and sampling period

Conversion speed is the rate at which an A/D converter module converts analog input values.

A sampling period is the period of conversion processing within the one channel.

A conversion period is the period of the update of a digital operation value with the A/D conversion method (sampling processing or averaging processing) taken into account, and is equivalent to an integral multiple of the sampling period. (Page 96, Section 8.6)

The following figure shows the relationship between conversion speed and a sampling period.

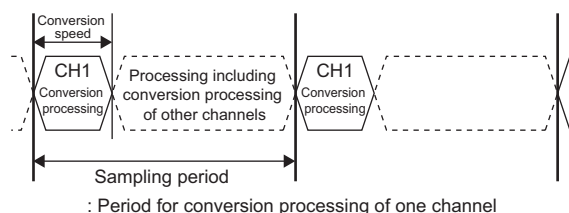

The sampling cycle varies depending on the type of main analog module, the conversion speed, the type of extension module, and the number of conversion enabled channels.

The following table shows the classification.

Main analog module	Extension module	Conversion speed setting	Sampling period ^{*1}	Reference
Main A/D converter module	<ul style="list-style-type: none"> Not connected Extension I/O module 	<ul style="list-style-type: none"> 100μs 400μs 1ms 	Conversion speed \times Number of conversion enabled channels	Page 92, Section 8.5.1 (1)
	Extension A/D converter module	100 μ s	200 μ s \times Number of conversion enabled channels	Page 92, Section 8.5.1 (2) (a)
		400 μ s	500 μ s \times Number of conversion enabled channels	Page 93, Section 8.5.1 (2) (b)
		1ms	1ms \times Number of conversion enabled channels	Page 93, Section 8.5.1 (2) (c)
Extension D/A converter module	<ul style="list-style-type: none"> 100μs 400μs 1ms 	200 μ s \times Number of conversion enabled channels	Page 94, Section 8.5.1 (3)	
Main D/A converter module	<ul style="list-style-type: none"> Not connected Extension I/O module 	–	100 μ s \times Number of conversion enabled channels	^{*2}
	Extension A/D converter module	–	200 μ s \times Number of conversion enabled channels	Page 95, Section 8.5.1 (4)
	Extension D/A converter module	–	200 μ s \times Number of conversion enabled channels	^{*2}

^{*1} For a D/A converter module, this column corresponds to the conversion period.

^{*2} For details, refer to the following:

- CC-Link IE Field Network Digital-Analog Converter Module User's Manual

(1) When an extension module is not connected or an extension I/O module is connected

The sampling period is given by the following:

Sampling period = Conversion speed × Number of conversion enabled channels

Ex. Assuming that the conversion speed setting is 100μs and the number of conversion enabled channels is 4

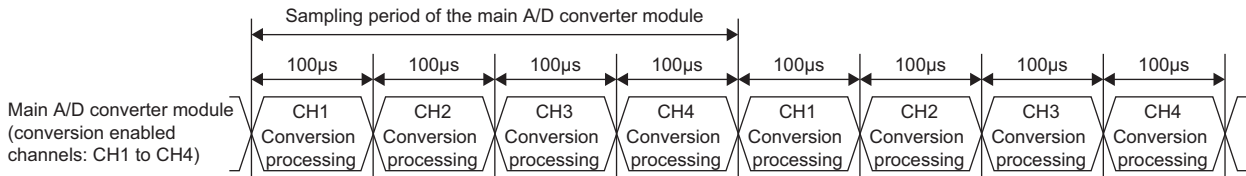

Sampling period of the main A/D converter module = 100μs × 4 = 400μs

(2) When an extension A/D converter module is connected to a main A/D converter module

When an extension A/D converter module is connected to a main A/D converter module, processing time (100μs) is generated between the conversion processing of each channel.

(a) With a conversion speed of 100μs

Between the conversion processing (100μs) of each channel, processing time (100μs) is generated. Therefore, the sampling period is given by the following:

Sampling period = (Conversion speed (100μs) + Processing time (100μs)) × Number of conversion enabled channels

Ex. Assuming that the conversion speed setting is 100μs and the number of conversion enabled channels is 4 for both the main A/D converter module and the extension A/D converter module

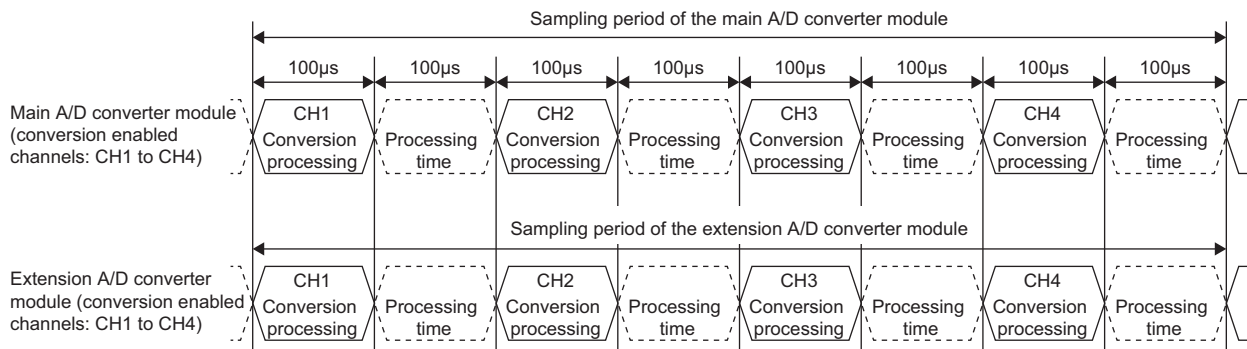

Sampling period of the main A/D converter module = (100μs + 100μs) × 4 = 800μs

Sampling period of the extension A/D converter module = (100μs + 100μs) × 4 = 800μs

(b) With a conversion speed of 400μs

Between the conversion processing (400μs) of each channel, processing time (100μs) is generated. Therefore, the sampling period is given by the following:

Sampling period = (Conversion speed (400μs) + Processing time (100μs)) × Number of conversion enabled channels

Ex. Assuming that the conversion speed setting is 400μs and the number of conversion enabled channels is 4 for both the main A/D converter module and the extension A/D converter module

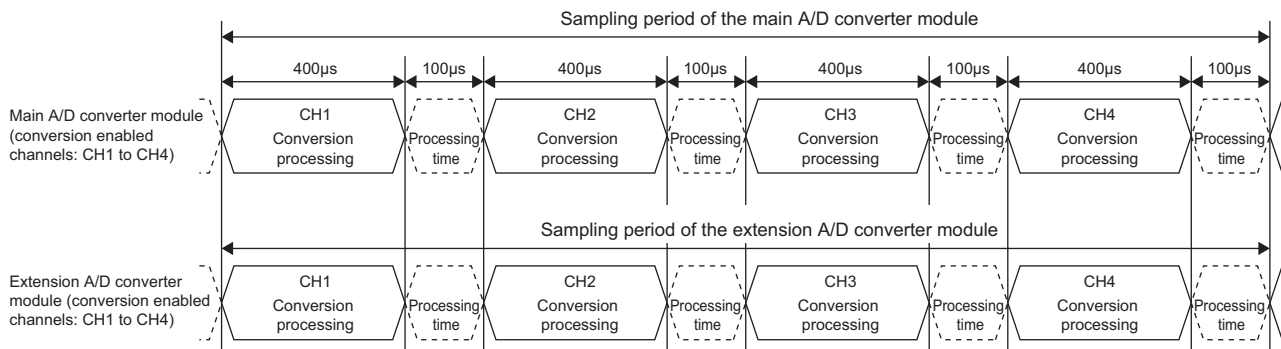

Sampling period of the main A/D converter module = $(400\mu\text{s} + 100\mu\text{s}) \times 4 = 2000\mu\text{s} = 2\text{ms}$

Sampling period of the extension A/D converter module = $(400\mu\text{s} + 100\mu\text{s}) \times 4 = 2000\mu\text{s} = 2\text{ms}$

(c) With a conversion speed of 1ms

With a conversion speed of 1ms, the time interval is 1ms including the processing time (100μs). Therefore, the sampling period is given by the following:

Sampling period = Conversion speed (1ms) × Number of conversion enabled channels

Ex. Assuming that the conversion speed setting is 1ms and the number of conversion enabled channels is 4 for both the main A/D converter module and the extension A/D converter module

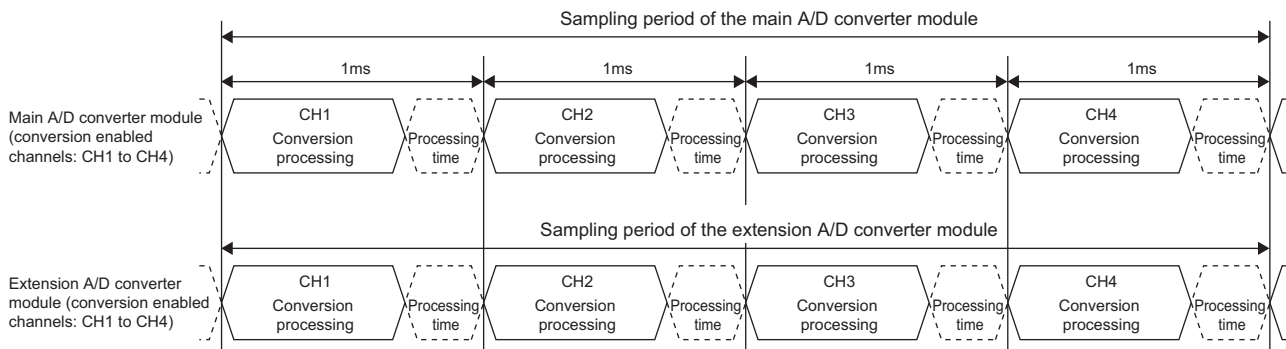

Sampling period of the main A/D converter module = $1\text{ms} \times 4 = 4\text{ms}$

Sampling period of the extension A/D converter module = $1\text{ms} \times 4 = 4\text{ms}$

If the number of conversion enabled channels is different between a main A/D converter module and an extension A/D converter module, the main A/D converter module and the extension A/D converter module perform A/D conversion at each different sampling period.

For example, assuming the following settings:

- Conversion speed setting: 100μs
- Conversion enabled channels of the main A/D converter module: CH1, CH2, CH3 (number of conversion enabled channels: 3)
- Conversion enabled channels of the extension A/D converter module: CH1, CH2 (number of conversion enabled channels: 2)

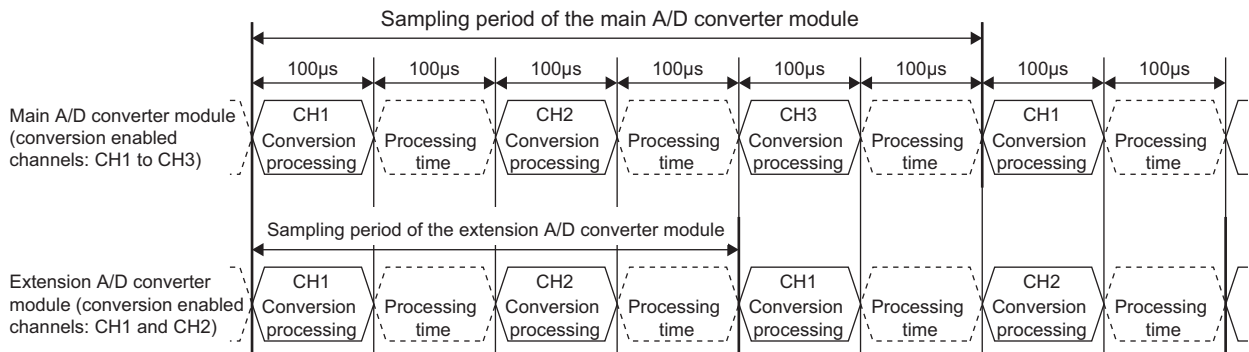

Sampling period of the main A/D converter module = (Conversion speed (100μs) + Processing time (100μs)) × 3 = 600μs
 Sampling period of the extension A/D converter module = (Conversion speed (100μs) + Processing time (100μs)) × 2 = 400μs

(3) When an extension D/A converter module is connected to a main A/D converter module

When an extension D/A converter module is connected to a main A/D converter module, the conversion speed is fixed to 100μs for the main A/D converter module and the extension D/A converter module. The setting of the conversion speed switch (address: 0001H) is ignored. In addition, between the conversion processing of each channel, processing time (100μs) is generated.

Therefore, the sampling period of the main A/D converter module is given by the following:

Sampling period = (Conversion speed (100μs) + Processing time (100μs)) × Number of conversion enabled channels

Ex. Assuming that the number of conversion enabled channels is 4 for both the main A/D converter module and the extension D/A converter module

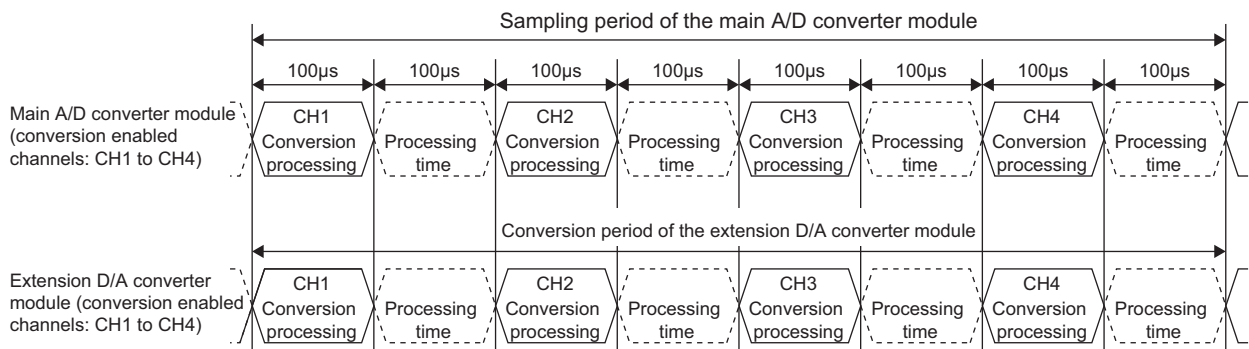

Sampling period of the main A/D converter module = (100μs + 100μs) × 4 = 800μs

Sampling period of the extension D/A converter module = (100μs + 100μs) × 4 = 800μs

(4) When an extension A/D converter module is connected to a main D/A converter module

When an extension A/D converter module is connected to a main D/A converter module, the conversion speed is fixed to 100μs for the main D/A converter module and the extension A/D converter module. In addition, between the conversion processing of each channel, processing time (100μs) is generated.

Therefore, the sampling period of the extension A/D converter module is given by the following:

Sampling period = (Conversion speed (100μs) + Processing time (100μs)) × Number of conversion enabled channels

Ex. Assuming that the number of conversion enabled channels is 4 for both the main D/A converter module and the extension A/D converter module

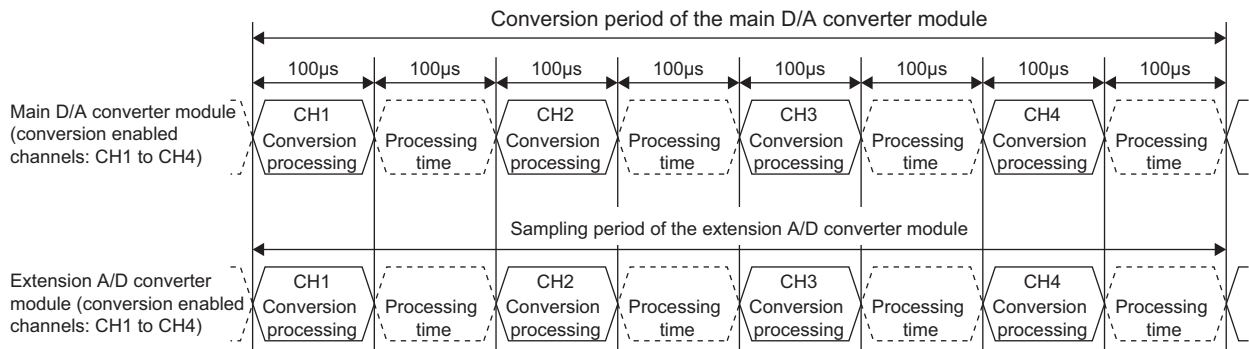

Sampling period of the main D/A converter module = (100μs + 100μs) × 4 = 800μs

Sampling period of the extension A/D converter module = (100μs + 100μs) × 4 = 800μs

8.6 A/D Conversion Method

Set whether to perform sampling processing or averaging processing for each channel.

(1) Sampling processing

This processing performs A/D conversion on analog input values in sequence. The converted values at this time are referred to as digital operation values.

For a main A/D converter module, digital operation values are stored into CH□ Digital operation value (RWr2 to RWr5) at every sampling periods. For an extension A/D converter module, digital operation values are stored into CH□ Digital operation value (RWr12 to RWr15) at every sampling periods.

The sampling period of the main A/D converter module and the extension A/D converter module depends on the conversion speed setting and the number of conversion enabled channels. For details, refer to the following:

- Conversion Speed and Sampling Period (📖 Page 91, Section 8.5.1)

(2) Averaging processing

This processing performs averaging processing on digital operation values for each channel, storing the average values into CH□ Digital operation value (RWr2 to RWr5, RWr12 to RWr15).

There are three types of averaging processing as follows:

- Time average
- Count average
- Moving average

(a) Time average

This processing performs A/D conversion for a set time and averages the total excluding the maximum and minimum values, storing the average value into CH□ Digital operation value (RWr2 to RWr5, RWr12 to RWr15).

The number of processing times varies depending on the sampling period.

$$\text{Number of processing times (times)} = \frac{\text{Setting time}}{\text{Sampling period}}$$

Ex. The number of processing times assuming the following settings with no extension module connected

Item	Setting
Number of channels used (number of channels where A/D conversion is enabled)	4 channels (CH1 to CH4)
Conversion speed	400µs/channel
Setting time	15ms

For the time average, the valid lower limit value to be set is given by: Minimum number of processing times, or $4 \times \text{Sampling period}$.

$$\frac{15}{(4 \times 0.4)} = 9.375 \text{ (times)} \cdot \cdot \cdot \text{Rounded down to the nearest whole number}$$

→ Nine times of measurement is performed to output the average value.

Point

For the time average, the valid lower limit value to be set is given by: Minimum number of processing times, or $4 \times$ Sampling period.

Example: A maximum of 4 channels is used (conversion speed: 1ms/channel)

$$(1\text{ms} \times 4) \times 4 = 16\text{ms}$$

If the number of processing times falls below four due to the set time, an error occurs (error code: 020□), where the digital operation value becomes 0.

(b) Count average

This processing performs A/D conversion for a set number of times and averages the total excluding the maximum and minimum values, storing the average value into CH□ Digital operation value (RWr2 to RWr5, RWr12 to RWr15).

The time taken to store the average value obtained by count average into CH□ Digital operation value (RWr2 to RWr5, RWr12 to RWr15) varies depending on the sampling period.

$$\text{Number of processing times} = \text{Set number of times} \times \text{Sampling period}$$

Ex. Processing times assuming the following settings with no extension module connected:

Item	Setting
Number of channels used (number of channels where A/D conversion is enabled)	4 channels (CH1 to CH4)
Conversion speed	400 μ s/channel
Set number of times	20 times

$$20 \times (4 \times 0.4) = 32.0 \text{ (ms)}$$

→ An average value is output every 32.0 ms.

Point

Because the count average requires a sum of at least two counts except the maximum and minimum values, the set number of times should be set to four or more.

(c) Moving average

This processing averages the digital output values taken in at each sampling cycle for a specified number of times, storing the average value into CH□ Digital operation value (RWr2 to RWr5, RWr12 to RWr15). Because the averaging processing is performed on a moving set of sampling processing, the latest digital operation values can be obtained.

The moving average processing for a set number of times of four is shown below:

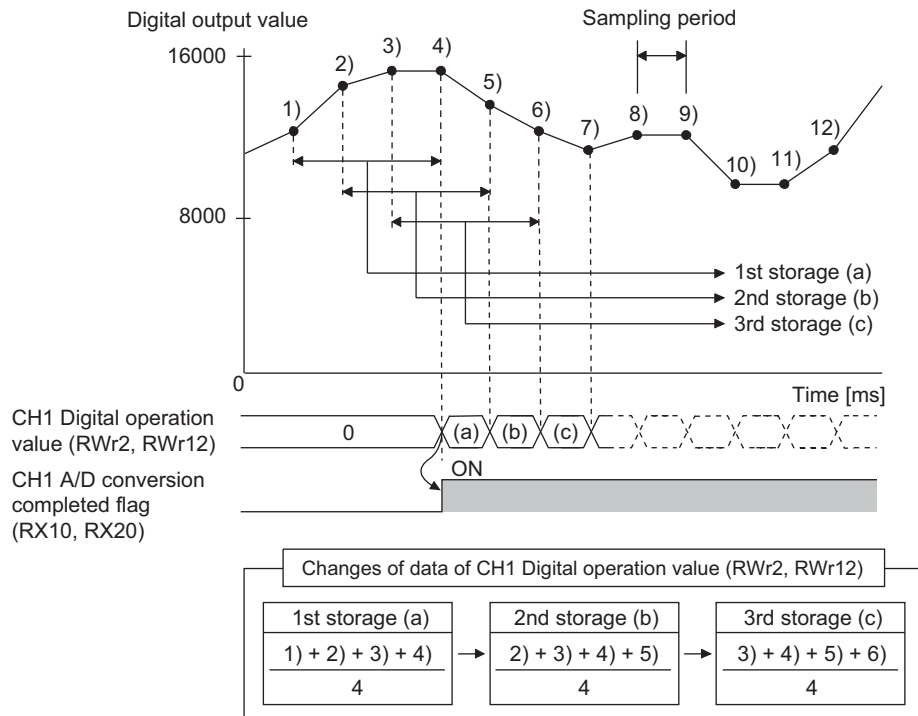

(3) Setting procedure

The setting procedure for the main A/D converter module is as follows:

(a) Sampling processing

1. Set "Method selection" to "Parameter write".

☞ "CC IE Field Configuration" window ⇒ Select the main A/D converter module from "List of stations"
 ⇒ [CC IE Field Configuration] ⇒ [Online] ⇒ [Parameter Processing of Slave Station]

2. In "Basic module parameter", set "CH□ A/D conversion enable/disable setting" to "0: Enable".

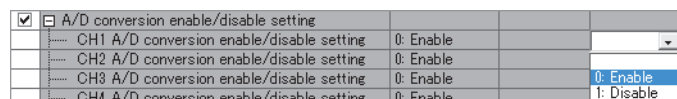

3. In "Basic module parameter", set "CH□ Averaging process setting" to "0: Sampling processing".

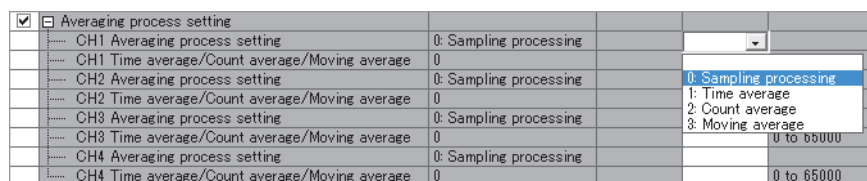

Point

For the extension A/D converter module, make the settings for each item of "Ext. module 1_Module parameter".

(b) Averaging processing**1. Set "Method selection" to "Parameter write".**

 "CC IE Field Configuration" window ⇒ Select the main A/D converter module from "List of stations"
⇒ [CC IE Field Configuration] ⇒ [Online] ⇒ [Parameter Processing of Slave Station]

2. In "Basic module parameter", set "CH□ A/D conversion enable/disable setting" to "0: Enable".

<input checked="" type="checkbox"/>	A/D conversion enable/disable setting			
<input type="checkbox"/>	CH1 A/D conversion enable/disable setting	0: Enable		
<input type="checkbox"/>	CH2 A/D conversion enable/disable setting	0: Enable		
<input type="checkbox"/>	CH3 A/D conversion enable/disable setting	0: Enable		0: Enable
<input type="checkbox"/>	CH4 A/D conversion enable/disable setting	0: Enable		1: Disable

3. In "Basic module parameter", specify the type of averaging processing for "CH□ Averaging process setting".

<input checked="" type="checkbox"/>	Averaging process setting			
<input type="checkbox"/>	CH1 Averaging process setting	0: Sampling processing		
<input type="checkbox"/>	CH1 Time average/Count average/Moving average	0		
<input type="checkbox"/>	CH2 Averaging process setting	0: Sampling processing		0: Sampling processing
<input type="checkbox"/>	CH2 Time average/Count average/Moving average	0		1: Time average
<input type="checkbox"/>	CH3 Averaging process setting	0: Sampling processing		2: Count average
<input type="checkbox"/>	CH3 Time average/Count average/Moving average	0		3: Moving average
<input type="checkbox"/>	CH4 Averaging process setting	0: Sampling processing		
<input type="checkbox"/>	CH4 Time average/Count average/Moving average	0		

Setting item	Setting range
CH□ Averaging process setting	<ul style="list-style-type: none"> • 1: Time average • 2: Count average • 3: Moving average

4. In "Basic module parameter", set the value of averaging processing in "CH□ Time average/Count average/Moving average".

<input checked="" type="checkbox"/>	Averaging process setting			
<input type="checkbox"/>	CH1 Averaging process setting	0: Sampling processing		1: Time average
<input type="checkbox"/>	CH1 Time average/Count average/Moving average	0		1000

Setting item	Selected processing for "CH□ Averaging process setting"	Setting range
CH□ Time average/Count average/Moving average	1: Time average*1	2 to 5000 (ms)
	2: Count average	4 to 65000 (times)
	3: Moving average	2 to 128 (times)

*1 For time average, set a value of (4 × Sampling period) ms or more. A value that does not satisfy this condition results in the error code (020□H, 120□H) being stored in Latest error code (RWr0), Error flag (RXA) turning on, and the ERR. LED lighting up. In CH□ Digital operation value (RWr2 to RWr5, RWr12 to RWr15), 0 is stored.

Point

For the extension A/D converter module, make the settings for each item of "Ext. module 1_Module parameter".

8.7 Range Switching Function

The input range can be selected for each channel from the following ranges:

- Factory default range (4 to 20mA, 0 to 20mA, 1 to 5V, 0 to 5V, -10 to 10V)
- User range (user range setting 1, user range setting 2)*1

*1 The main A/D converter module only permits the selection.

(1) Setting procedure

The setting procedure for the main A/D converter module is as follows:

1. Set "Method selection" to "Parameter write".

 "CC IE Field Configuration" window ⇒ Select the main A/D converter module from "List of stations"
 ⇒ [CC IE Field Configuration] ⇒ [Online] ⇒ [Parameter Processing of Slave Station]

2. In "Basic module parameter", set "CH□ A/D conversion enable/disable setting" to "0: Enable".

<input checked="" type="checkbox"/>	A/D conversion enable/disable setting				
	CH1 A/D conversion enable/disable setting	0: Enable			
	CH2 A/D conversion enable/disable setting	0: Enable			
	CH3 A/D conversion enable/disable setting	0: Enable		0: Enable	
	CH4 A/D conversion enable/disable setting	0: Enable		1: Disable	

3. In "Basic module parameter", set up "CH□ Range setting".

<input checked="" type="checkbox"/>	Range setting					
	CH1 Range setting	0: 4 to 20mA				Set
	CH2 Range setting	0: 4 to 20mA				
	CH3 Range setting	0: 4 to 20mA		0: 4 to 20mA		
	CH4 Range setting	0: 4 to 20mA		1: 0 to 20mA		
<input checked="" type="checkbox"/>	Averaging process setting			2: 1 to 5V		
	CH1 Averaging process setting	0: Sampling pr...		3: 0 to 5V		
	CH1 Time average/Count average/Mov...	0		4: -10 to 10V		
	CH2 Averaging process setting	0: Sampling pr		5: User range setting1(-10 to 10V)		
				6: User range setting2(-5 to 5V,0 to 20mA)		



For the extension A/D converter module, make the settings for each item of "Ext. module 1_Module parameter".

8.8 Maximum Value/Minimum Value Hold Function

For each channel, this function stores the maximum value and the minimum value of digital operation values into the following remote buffer memory.

Main or extension	Remote buffer memory address							
	CH1		CH2		CH3		CH4	
	Maximum value	Minimum value	Maximum value	Minimum value	Maximum value	Minimum value	Maximum value	Minimum value
Main A/D converter module	0601H	0602H	0603H	0604H	0605H	0606H	0607H	0608H
Extension A/D converter module	0701H	0702H	0703H	0704H	0705H	0706H	0707H	0708H

If averaging processing is specified, the values are updated per averaging process cycle. Otherwise they are updated per sampling cycle.

(1) Resetting maximum and minimum values

- Turning on and off Maximum value/minimum value reset request (RY1D) of the main A/D converter module allows the maximum and minimum values of the main A/D converter module to be updated to the current values.
- Turning on and off Maximum value/minimum value reset request (RY2D) of the extension A/D converter module allows the maximum and minimum values of the extension A/D converter module to be updated to the current values.
- Turning on and off Initial data setting request flag (RY9) allows the maximum and minimum values of both the main A/D converter module and the extension A/D converter module to be updated to the current values.

(2) Target of the maximum and minimum values

The maximum and minimum values of digital operation values are stored into the remote buffer memory.

For details, refer to the following:

- Each Function in the Sequence (👉 Page 89, Section 8.3)

8.9 Input Signal Error Detection Function

This function detects a disconnection of an analog input signal.

The following figure schematically shows how the input signal error detection works in the main A/D converter module.

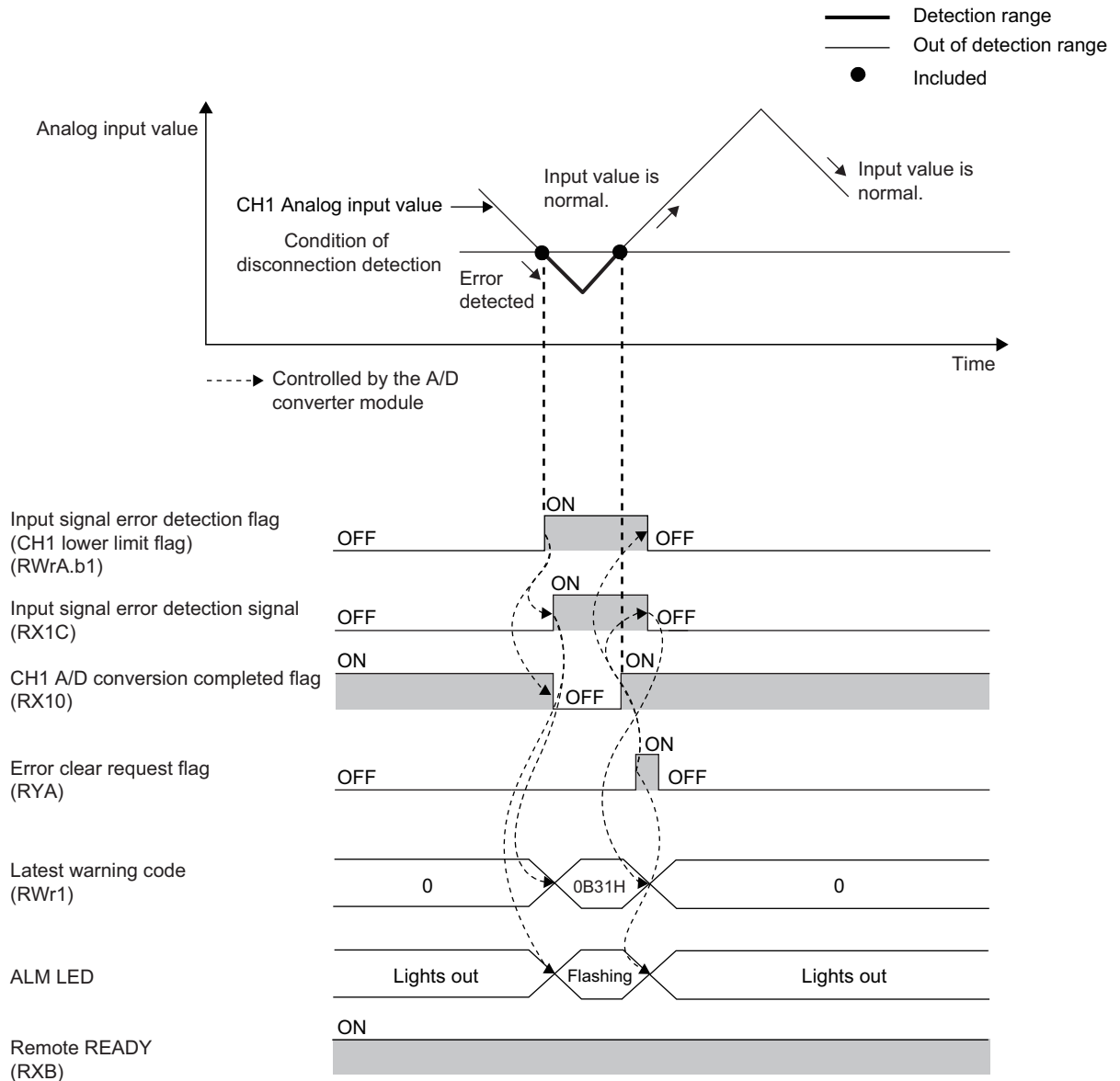

(1) Detection condition

When the following condition is satisfied, a disconnection is detected.

Input range*1	Disconnection detection condition
4 to 20mA	Input analog value $\leq 2\text{mA}$
1 to 5V	Input analog value $\leq 0.5\text{V}$

*1 An input range other than the above results in the error code (082□H or 182□H) being stored in Latest error code (RWr0), Error flag (RXA) turning on, and the ERR. LED lighting up, with operation at the previous settings.

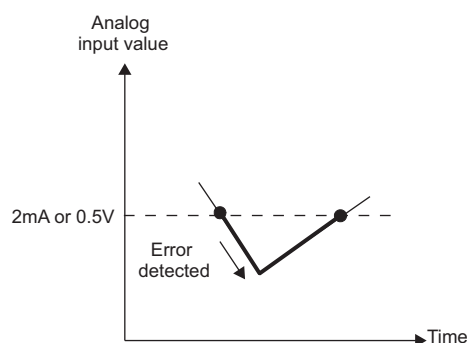

(2) Notification of an input signal error

(a) For the main A/D converter module

If the analog input value is satisfied the disconnection detection condition, the A/D converter module results in the following state and an error is notified.

- Input signal error detection flag (RWrA): The bit of the corresponding channel turns on. (☞ Page 203, Appendix 2 (5))
- Input signal error detection signal (RX1C): On
- ALM LED of the main module: Flashing

In addition, the alarm code 0B△□ is stored in Latest warning code (RWr1).

(b) For the extension A/D converter module

If the analog input value is satisfied the disconnection detection condition, the A/D converter module results in the following state and an error is notified.

- Input signal error detection flag (RWr1A): The bit of the corresponding channel turns on. (☞ Page 203, Appendix 2 (5))
- Input signal error detection signal (RX2C): On
- ALM LED of the main module: Flashing

In addition, the alarm code 1B△□ is stored in Latest warning code (RWr1).

For details on alarm codes, refer to the following:

- Alarm Code List (☞ Page 181, Section 11.3)

(3) How the input signal error detection function operates

(a) For the main A/D converter module

The digital operation value of the channel in which an error is detected is held at the value just before the error detection, and CH□ A/D conversion completed flag (RX10 to RX13) of the corresponding channel turns off. In addition, once the analog input value returns to a value that is larger than the criteria of disconnection detection, A/D conversion resumes regardless of the reset of Input signal error detection flag (RWrA) and Input signal error detection signal (RX1C). After the first update, CH□ A/D conversion completed flag (RX10 to RX13) of the corresponding channel turns on again. (The ALM LED of the main module keeps flashing.)

(b) For the extension A/D converter module

The digital operation value of the channel in which an error is detected is held at the value just before the error detection, and CH□ A/D conversion completed flag (RX20 to RX23) of the corresponding channel turns off. In addition, once the analog input value returns to a value that is larger than the criteria of disconnection detection, A/D conversion resumes regardless of the reset of Input signal error detection flag (RWr1A) and Input signal error detection signal (RX2C). After the first update, CH□ A/D conversion completed flag (RX20 to RX23) of the corresponding channel turns on again. (The ALM LED of the main module keeps flashing.)

Point

The digital operation value is not updated while the input signal error is being detected. Once the analog input value is out of the disconnection detection condition, updating the digital operation value resumes.

(4) Detection cycle

This function is executed per sampling cycle.

(5) Clearing the input signal error detection

Check that the analog input value returns to a value that is larger than the criteria of disconnection detection and Error flag (RXA) turns off, and then turn on and off Error clear request flag (RYA).

When the input signal error is cleared, the A/D converter module results in the following state:

- Input signal error detection flag (RWrA, RWr1A) is cleared.
- Input signal error detection signal (RX1C, RX2C) turns off.
- The ALM LED turns off.
- The alarm code stored in Latest warning code (RWr1) is cleared.

(6) Setting procedure

The setting procedure for the main A/D converter module is as follows:

1. Set "Method selection" to "Parameter write".

 "CC IE Field Configuration" window ⇒ Select the main A/D converter module from "List of stations"
⇒ [CC IE Field Configuration] ⇒ [Online] ⇒ [Parameter Processing of Slave Station]

2. In "Basic module parameter", set "CH□ A/D conversion enable/disable setting" to "0: Enable".

<input checked="" type="checkbox"/>	A/D conversion enable/disable setting			
<input type="checkbox"/>	CH1 A/D conversion enable/disable setting	0: Enable		
<input type="checkbox"/>	CH2 A/D conversion enable/disable setting	0: Enable		
<input type="checkbox"/>	CH3 A/D conversion enable/disable setting	0: Enable		0: Enable
<input type="checkbox"/>	CH4 A/D conversion enable/disable setting	0: Enable		1: Disable

3. In "Basic module parameter", set "CH□ Input signal error detection setting" to "4: Disconnection detection".

<input checked="" type="checkbox"/>	Input signal error detection function			
<input type="checkbox"/>	CH1 Input signal error detection setting	0: Disable		
<input type="checkbox"/>	CH2 Input signal error detection setting	0: Disable		
<input type="checkbox"/>	CH3 Input signal error detection setting	0: Disable		0: Disable
<input type="checkbox"/>	CH4 Input signal error detection setting	0: Disable		4: Disconnection detection

Point

For the extension A/D converter module, make the settings for each item of "Ext. module 1_Module parameter".

8.10 Alert Output Function (Process Alarm)

This function outputs an alert when a digital operation value falls within the alert output range set in advance. The following figure schematically shows how the alert output behaves in the main A/D converter module.

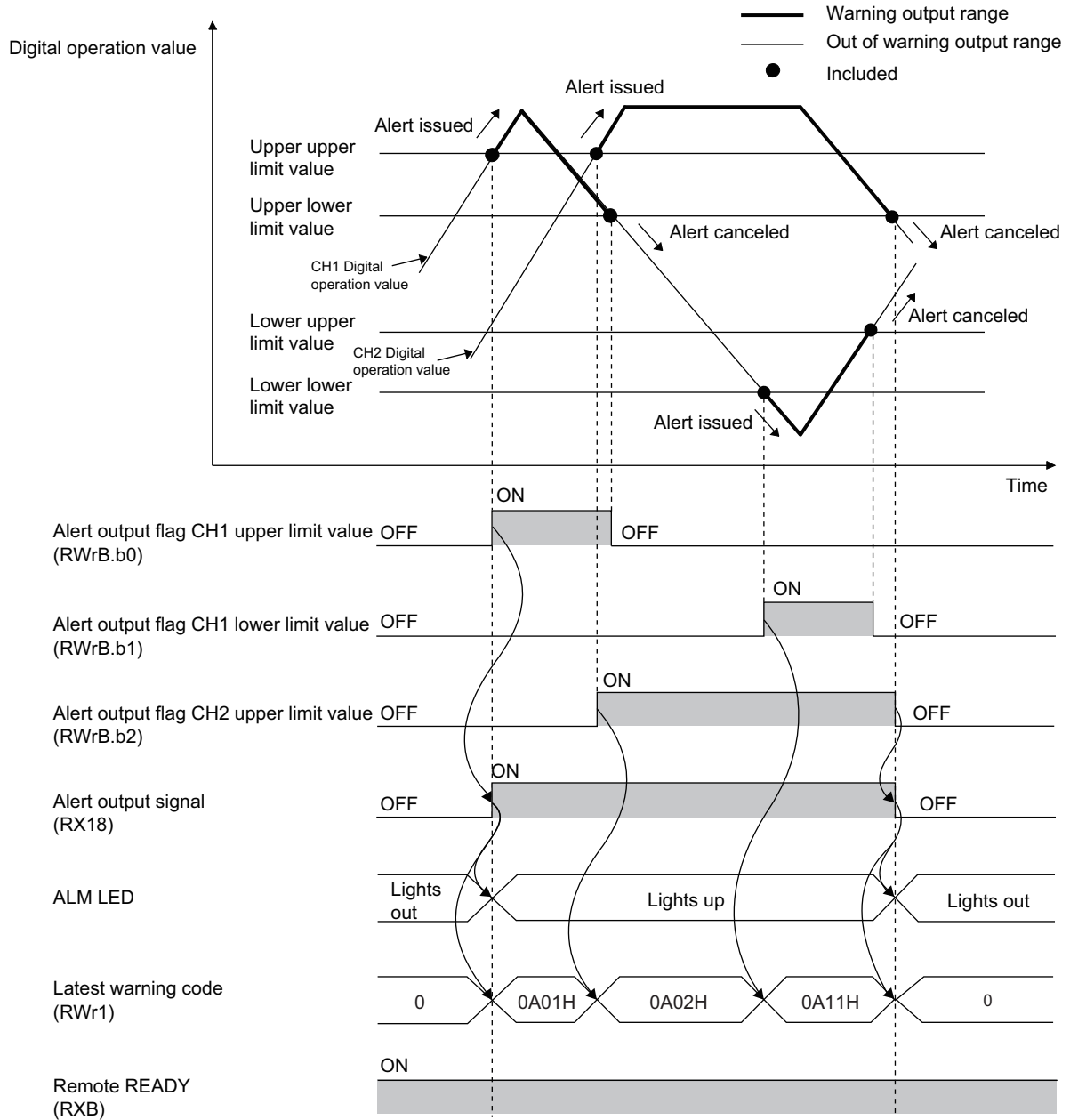

(1) Process alarm notification

(a) For the main A/D converter module

If a digital operation value enters the alert output range, being equal to or greater than the process alarm upper upper limit value, or being equal to or less than the process alarm lower lower limit value, Alert output flag (RWrB), Alert output signal (RX18), and the turning on of the ALM LED of the main module notify an alert.

- Alert output flag (RWrB): The bit corresponding to the contents of the alert turns on. (☞ Page 204, Appendix 2 (6))
- Alert output signal (RX18): On
- ALM LED of the main module: On

In addition, the alarm code 0A△□ is stored in Latest warning code (RWr1).

(b) For the extension A/D converter module

If a digital operation value enters the alert output range, being equal to or greater than the process alarm upper upper limit value, or being equal to or less than the process alarm lower lower limit value, Alert output flag (RWr1B), Alert output signal (RX28), and the turning on of the ALM LED of main module notify an alert.

- Alert output flag (RWr1B): The bit corresponding to contents of the alert turns on. (☞ Page 204, Appendix 2 (6))
- Alert output signal (RX28): On
- ALM LED of the main module: On

In addition, the alarm code 1A△□ is stored in Latest warning code (RWr1).

For details on alarm codes, refer to the following:

- Alarm Code List (☞ Page 181, Section 11.3)

(2) How the alert output function (process alarm) operates

After alert output, if a digital operation value enters the alert output set range, being less than the process alarm upper lower limit value, or being greater than the process alarm lower upper limit value, "0" is stored in the bit position corresponding to the channel number of Alert output flag (RWrB, RWr1B).

Once all the channels return to within the set range, Alert output signal (RX18, RX28) turns off and the ALM LED goes off.

(3) Detection cycle

When time average is specified, the function is executed per set time (for averaging). When count average is specified, the function is executed per set count (for averaging).

In addition, when sampling processing and moving average are specified, the function is executed per sampling cycle.

(4) Clearing the alarm code

When a digital operation value enters the range "Process alarm lower upper limit value < Digital operation value < Process alarm upper lower limit value", the alarm code (0A△□H or 1A△□H) stored in Latest warning code (RWr1) is automatically cleared.

(5) Alert output target

Alert output target is CH□ Digital operation value (RWr2 to RWr5, RWr12 to RWr15).

When using the digital clipping function, scaling function, shift function, and difference conversion function, set values considering these functions for the process alarm upper upper limit value, upper lower limit value, lower upper limit value, and lower lower limit value.

(6) Setting procedure

The setting procedure for the main A/D converter module is as follows:

1. Set "Method selection" to "Parameter write".

 "CC IE Field Configuration" window ⇒ Select the main A/D converter module from "List of stations"
⇒ [CC IE Field Configuration] ⇒ [Online] ⇒ [Parameter Processing of Slave Station]

2. In "Basic module parameter", set "CH□ A/D conversion enable/disable setting" to "0: Enable".

<input checked="" type="checkbox"/>	A/D conversion enable/disable setting			
	CH1 A/D conversion enable/disable setting	0: Enable		
	CH2 A/D conversion enable/disable setting	0: Enable		
	CH3 A/D conversion enable/disable setting	0: Enable	0: Enable	
	CH4 A/D conversion enable/disable setting	0: Enable		1: Disable

3. In "Basic module parameter", set "CH□ Alert output setting" to "0: Enable".

<input checked="" type="checkbox"/>	Alert output function			
	CH1 Alert output setting	1: Disable		
	CH1 Process alarm upper upper limit value	0		
	CH1 Process alarm upper lower limit value	0	0: Enable	
	CH1 Process alarm lower upper limit value	0		1: Disable

4. In "Basic module parameter", specify the values for "CH□; Process alarm upper upper limit value", "CH□ Process alarm upper lower limit value", "CH□ Process alarm lower upper limit value", and "CH□ Process alarm lower lower limit value".

<input checked="" type="checkbox"/>	Alert output function			
	CH1 Alert output setting	1: Disable		0: Enable
	CH1 Process alarm upper upper limit value	0		16000
	CH1 Process alarm upper lower limit value	0		10000
	CH1 Process alarm lower upper limit value	0		3000
	CH1 Process alarm lower lower limit value	0		0

Item	Setting range
CH□ Process alarm upper upper limit value	-32768 to 32767
CH□ Process alarm upper lower limit value	
CH□ Process alarm lower upper limit value	
CH□ Process alarm lower lower limit value	

Point

- Alert output function must meet the following condition:
Process alarm upper upper limit value ≥ Process alarm upper lower limit value ≥ Process alarm lower upper limit value ≥ Process alarm lower lower limit value
- For the extension A/D converter module, make the settings for each item of "Ext. module 1_Module parameter".

8.11 Scaling Function

This function performs scale conversion on a digital output value with the range of the scaling lower limit value and the scaling upper limit value, both of which are set at desired values.

The value after scale conversion is stored in CH□ Digital operation value (RWr2 to RWr5, RWr12 to RWr15).

(1) How to interpret the scaling setting

Ex. If the input range is set to -10 to 10V:

For the scaling lower limit value, set a value corresponding to the lower limit of the input range (-16000), and for the scaling upper limit value, set a value corresponding to the upper limit of the input range (16000).

(2) Calculation of the digital operation value

Scale conversion is performed on the digital values using the following formula:

(A value is rounded off to the nearest whole number during scale conversion.)

- If the input range is -10 to 10V

$$\text{Digital operation value} = \frac{D_X \times (S_H - S_L)}{32000} + \frac{(S_H + S_L)}{2}$$

- If the input range is user range setting 1, user range setting 2, 0 to 5V, 1 to 5V, 0 to 20mA, or 4 to 20mA

$$\text{Digital operation value} = \frac{D_X \times (S_H - S_L)}{16000} + S_L$$

Item	Description
D_X	Digital output value
S_H	Scaling upper limit value
S_L	Scaling lower limit value

(3) Setting procedure

The setting procedure for the main A/D converter module is as follows:

1. Set "Method selection" to "Parameter write".

 "CC IE Field Configuration" window ⇒ Select the main A/D converter module from "List of stations"
⇒ [CC IE Field Configuration] ⇒ [Online] ⇒ [Parameter Processing of Slave Station]

2. In "Basic module parameter", set "CH□ A/D conversion enable/disable setting" to "0: Enable".

<input checked="" type="checkbox"/>	A/D conversion enable/disable setting			
 CH1 A/D conversion enable/disable setting	0: Enable		
 CH2 A/D conversion enable/disable setting	0: Enable		
 CH3 A/D conversion enable/disable setting	0: Enable		0: Enable
 CH4 A/D conversion enable/disable setting	0: Enable		1: Disable

3. In "Basic module parameter", set "CH□ Scaling enable/disable setting" to "0: Enable".

<input checked="" type="checkbox"/>	Scaling function			
 CH1 Scaling enable/disable setting	1: Disable		
 CH1 Scaling upper limit value	0		
 CH1 Scaling lower limit value	0		0: Enable
 CH2 Scaling enable/disable setting	1: Disable		1: Disable

4. In "Basic module parameter", set the values in "CH□ Scaling upper limit value" and "CH□ Scaling lower limit value".

<input checked="" type="checkbox"/>	Scaling function			
 CH1 Scaling enable/disable setting	1: Disable		0: Enable
 CH1 Scaling upper limit value	0		16000
 CH1 Scaling lower limit value	0		4000

Item	Setting range
CH□ Scaling upper limit value	-32000 to 32000
CH□ Scaling lower limit value	

Point

- Even if the scaling upper limit value and the scaling lower limit value are set so that the change is larger than the maximum resolution described in the performance specifications, the resolution will not increase.
- Scaling settings must meet the following condition:
Scaling upper limit value > Scaling lower limit value
- For the extension A/D converter module, make the settings for each item of "Ext. module 1_Module parameter".

(4) Example of the scaling setting

Ex. 1: For the channel with the set input range of 0 to 5V, of the main A/D converter module, settings are made as follows:

- "CH□ Scaling enable/disable setting": "0: Enable"
- "CH□ Scaling upper limit value": 12000
- "CH□ Scaling lower limit value": 4000

<input checked="" type="checkbox"/>	Scaling function		
	CH1 Scaling enable/disable setting	1: Disable	0: Enable
	CH1 Scaling upper limit value	0	12000
	CH1 Scaling lower limit value	0	4000

The digital output value and the digital operation value would be as follows:

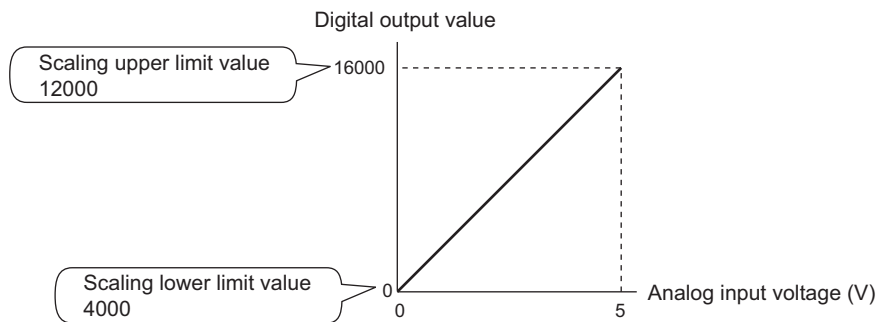

Analog input voltage (V)	Digital output value	Digital operation value
0	0	4000
1	3200	5600
2	6400	7200
3	9600	8800
4	12800	10400
5	16000	12000

Ex. 2: For the channel with the set input range of -10 to 10V, of the main A/D converter module, settings are made as follows:

- "CH \square Scaling enable/disable setting": "0: Enable"
- "CH \square Scaling upper limit value": 12000
- "CH \square Scaling lower limit value": 4000

<input checked="" type="checkbox"/>	Scaling function			
	CH1 Scaling enable/disable setting	1: Disable		0: Enable
	CH1 Scaling upper limit value	0		12000
	CH1 Scaling lower limit value	0		4000

The digital output value and the digital operation value would be as follows:

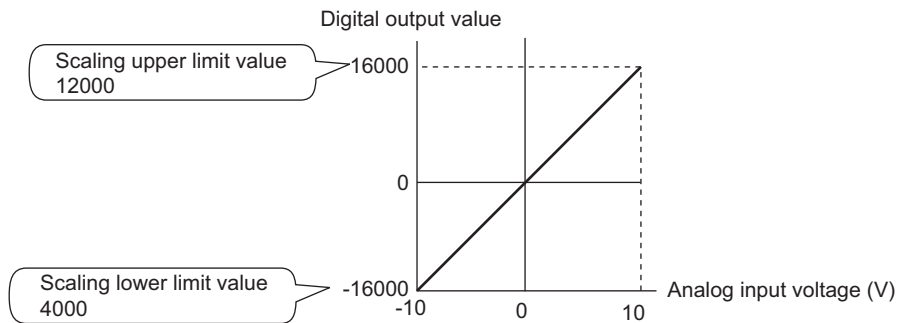

Analog input voltage (V)	Digital output value	Digital operation value
-10	-16000	4000
-5	-8000	6000
0	0	8000
5	8000	10000
10	16000	12000

Ex. 3: For the channel with the set user range of 2 to 10V, of the main A/D converter module, settings are made as follows:

- "CH□ Scaling enable/disable setting": "0: Enable"
- "CH□ Scaling upper limit value": 12000
- "CH□ Scaling lower limit value": 4000

<input checked="" type="checkbox"/>	Scaling function		
<input type="checkbox"/>	CH1 Scaling enable/disable setting	1: Disable	0: Enable
<input type="checkbox"/>	CH1 Scaling upper limit value	0	12000
<input type="checkbox"/>	CH1 Scaling lower limit value	0	4000

The digital output value and the digital operation value would be as follows:

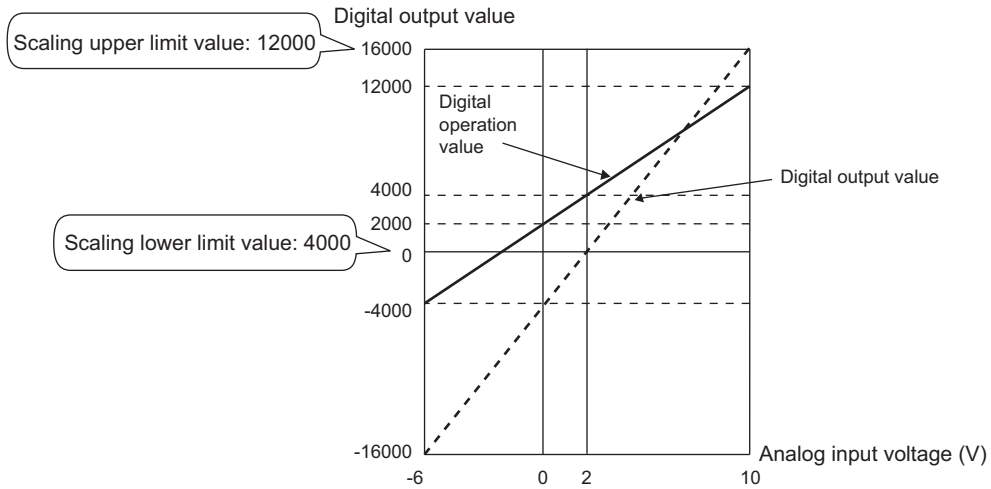

Analog input voltage (V)	Digital output value	Digital operation value
-6	-16000	-4000
-4	-12000	-2000
-2	-8000	0
0	-4000	2000
2	0	4000
4	4000	6000
6	8000	8000
8	12000	10000
10	16000	12000

8.12 Shift Function

This function adds (shifts) the set conversion value shift amount to a digital output value. When the conversion value shift amount is changed, it is reflected to the digital operation value in real time. Therefore, fine adjustment can be easily performed when the system starts.

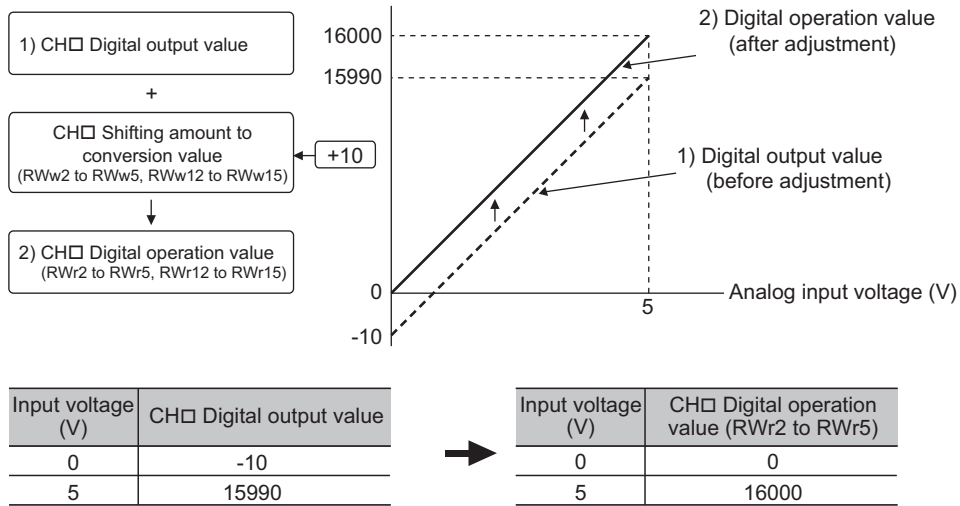

(1) How the shift function operates

The set conversion value shift amount is added to digital output value. Then, the digital operation value after shift-and-add is stored in CH□ Digital operation value (RWr2 to RWr5, RWr12 to RWr15).
 When the scaling function is used, the conversion value shift amount is added to the value to which the scale-conversion is performed.
 The shift amount is added in every sampling cycle for sampling processing, while it is added in every averaging process cycle for averaging processing.
 The default value of the conversion value shift amount is "0". If a value is set to the conversion value shift amount, this conversion value shift amount is added regardless of turning on and off Initial data setting request flag (RY9).

(2) Setting procedure

The setting procedure for the main A/D converter module is as follows:

1. Set "Method selection" to "Parameter write".

☞ "CC IE Field Configuration" window ⇒ Select the main A/D converter module from "List of stations"
 ⇒
 [CC IE Field Configuration] ⇒ [Online] ⇒ [Parameter Processing of Slave Station]

2. In "Basic module parameter", set "CH□ A/D conversion enable/disable setting" to "0: Enable".

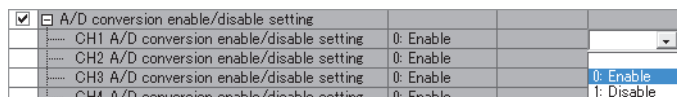

3. Set the value to be added to CH□ Shifting amount to conversion value (RWw2 to RWw5).

Item	Setting range
CH□ Shifting amount to conversion value (RWw2 to RWw5)	-32768 to 32767

Point

- If the digital operation value exceeds the range of -32768 to 32767 as a result of shift addition, the digital operation value is fixed to the lower limit value (-32768) or the upper limit value (32767).
- For the extension A/D converter module, go to "Ext. module 1_Module parameter" and set "Ext. module 1_CH□ A/D conversion enable/disable setting" to "0: Enable", and then set the value to be added in CH□ Shifting amount to conversion value (RWw12 to RWw15).

(3) Setting example

Ex. For the channel with the set input range of -10 to 10V, of the main A/D converter module, settings are made as follows:

- CH□ Shifting amount to conversion value (RWw2 to RWw5): 20000

The digital output values and digital operation values are as follows:

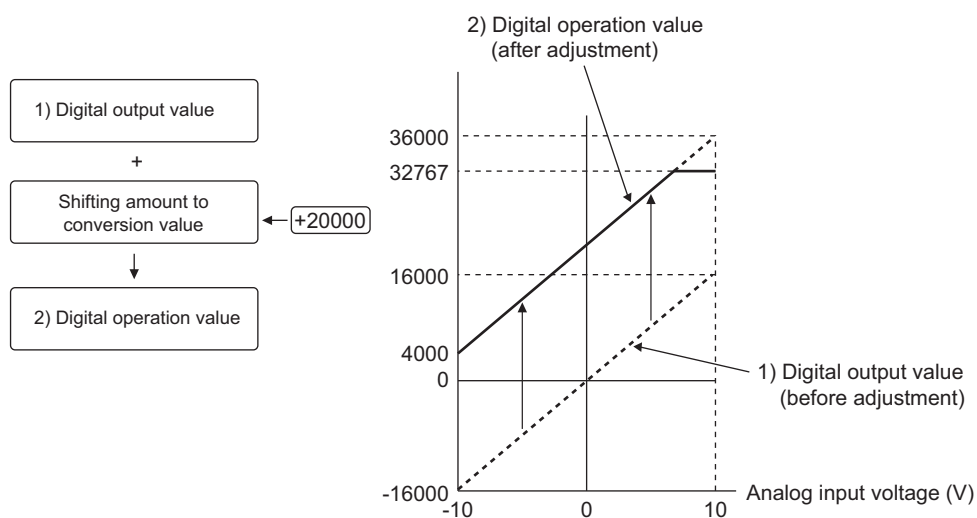

Input voltage (V)	Digital output value	Digital operation value
-10	-16000	4000
-5	-8000	12000
0	0	20000
5	8000	28000
10	16000	32767 ^{*1}

*1 Because the value exceeds the range of -32768 to 32767, it is fixed to 32767 (the upper limit value).

(4) Example of the combined use of the scaling function and the shift function

Ex. For the channel with the set input range of 0 to 5V, of the main A/D converter module, settings are made as follows:

- "CH□ Scaling enable/disable setting": "0: Enable"
- "CH□ Scaling upper limit value": 12000
- "CH□ Scaling lower limit value": 2000
- CH□ Shifting amount to conversion value (RWw2 to RWw5): 2000

The digital output values and digital operation values are as follows:

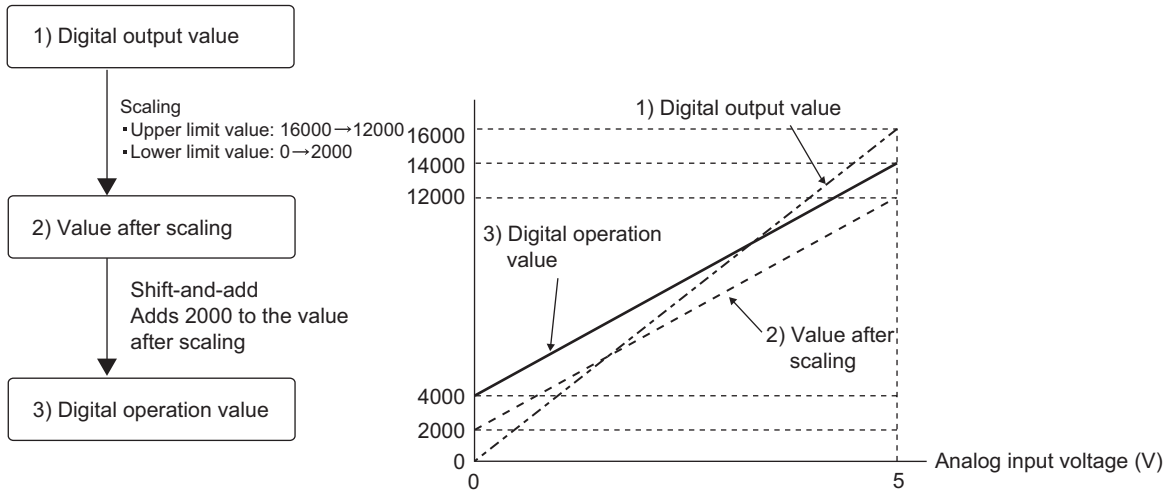

Input voltage (V)	Digital output value	Value after scaling	Digital operation value
0	0	2000	4000
1	3200	4000	6000
2	6400	6000	8000
3	9600	8000	10000
4	12800	10000	12000
5	16000	12000	14000

1. Set "Parameter write" for "Method selection".

"CC IE Field Configuration" window ⇒ Select the main A/D converter module from "List of stations"
⇒ [CC IE Field Configuration] ⇒ [Online] ⇒ [Parameter Processing of Slave Station]

2. In "Basic module parameter", set "CH□ A/D conversion enable/disable setting" to "0: Enable".

A/D conversion enable/disable setting			
CH1 A/D conversion enable/disable setting	0: Enable		
CH2 A/D conversion enable/disable setting	0: Enable		
CH3 A/D conversion enable/disable setting	0: Enable		0: Enable
CH4 A/D conversion enable/disable setting	0: Enable		1: Disable

3. In "Basic module parameter", set "CH□ Scaling enable/disable setting" to "0: Enable".

Scaling function			
CH1 Scaling enable/disable setting	1: Disable		
CH1 Scaling upper limit value	0		
CH1 Scaling lower limit value	0		0: Enable
CH2 Scaling enable/disable setting	1: Disable		1: Disable

4. In "Basic module parameter", set the values in "CH□ Scaling upper limit value" and "CH□ Scaling lower limit value".

<input checked="" type="checkbox"/>	Scaling function		
	CH1 Scaling enable/disable setting	1: Disable	0: Enable
	CH1 Scaling upper limit value	0	12000
	CH1 Scaling lower limit value	0	2000

5. Set CH□ Shifting amount to conversion value (RWw2 to RWw5) to "2000".

Point

When the shift function, digital clipping function, and scaling function are used together, shift addition is executed on the value after digital clipping and scale conversion. In this case, the range of the digital operation value is determined as -32768 to 32767.

For a setting example of when the digital clipping function, scaling function, and shift function are used together, refer to the following:

- Example of the combined use of the digital clipping function, the scaling function, and the shift function ( Page 121, Section 8.13 (4))

8.13 Digital Clipping Function

The range of a digital operation value is fixed between the maximum digital output value and the minimum digital output value if the input voltage or current exceeds the input range.

(1) How to interpret the digital clipping setting

The following table shows how the output range of a digital output value changes by enabling the digital clipping function for each range.

Input range	Output range of a digital operation value	
	Digital clipping function disabled	Digital clipping function enabled
4 to 20mA	-384 to 16383	0 to 16000
0 to 20mA		
1 to 5V		
0 to 5V		
-10 to 10V	-16384 to 16383	-16000 to 16000
User range setting 1 (-10 to 10V)		
User range setting 2 (-5 to 5V, -20 to 20mA)		

(2) Setting procedure

The setting procedure for the main A/D converter module is as follows:

1. Set "Method selection" to "Parameter write".

 "CC IE Field Configuration" window ⇒ Select the main A/D converter module from "List of stations"
⇒ [CC IE Field Configuration] ⇒ [Online] ⇒ [Parameter Processing of Slave Station]

2. In "Basic module parameter", set "CH□ A/D conversion enable/disable setting" to "0: Enable".

<input checked="" type="checkbox"/>	A/D conversion enable/disable setting			
	CH1 A/D conversion enable/disable setting	0: Enable		
	CH2 A/D conversion enable/disable setting	0: Enable		
	CH3 A/D conversion enable/disable setting	0: Enable		
	CH4 A/D conversion enable/disable setting	0: Enable		1: Disable

3. In "Basic module parameter", set "CH□ Digital clipping enable/disable setting" to "0: Enable".

<input checked="" type="checkbox"/>	Digital clipping function			
	CH1 Digital clipping enable/disable setting	1: Disable		
	CH2 Digital clipping enable/disable setting	1: Disable		
	CH3 Digital clipping enable/disable setting	1: Disable		0: Enable
	CH4 Digital clipping enable/disable setting	1: Disable		1: Disable



For the extension A/D converter module, make the settings for each item of "Ext. module 1_Module parameter".

(3) Example of the combined use of the digital clipping function and the scaling function

Ex. For the channel with the set input range of 0 to 5V, of the main A/D converter module, settings are made as follows:

- "CH□ Scaling enable/disable setting": "0: Enable"
- "CH□ Scaling upper limit value": 24000
- "CH□ Scaling lower limit value": 0
- "CH□ Digital clipping enable/disable setting": "0: Enable"

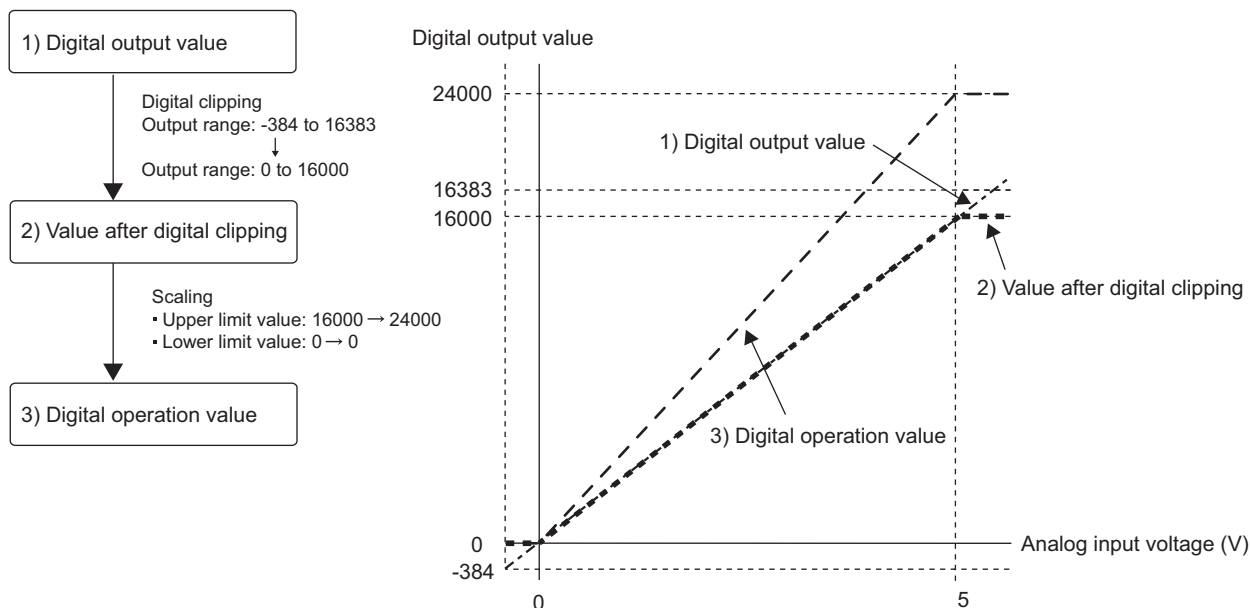

Input voltage (V)	Digital output value	Digital operation value
-0.12	-384	0
0	0	0
1	3200	4800
2	6400	9600
3	9600	14400
4	12800	19200
5	16000	24000
5.12	16383	24000

1. Set "Parameter write" for "Method selection".

☞ "CC IE Field Configuration" window ⇒ Select the main A/D converter module from "List of stations"
 ⇒ [CC IE Field Configuration] ⇒ [Online] ⇒ [Parameter Processing of Slave Station]

2. In "Basic module parameter", set "CH□ A/D conversion enable/disable setting" to "0: Enable".

<input checked="" type="checkbox"/>	A/D conversion enable/disable setting		
<input type="checkbox"/>	CH1 A/D conversion enable/disable setting	0: Enable	
<input type="checkbox"/>	CH2 A/D conversion enable/disable setting	0: Enable	
<input type="checkbox"/>	CH3 A/D conversion enable/disable setting	0: Enable	0: Enable
<input type="checkbox"/>	CH4 A/D conversion enable/disable setting	0: Enable	1: Disable

3. In "Basic module parameter", set "CH□ Scaling enable/disable setting" to "0: Enable".

<input checked="" type="checkbox"/>	Scaling function			
	CH1 Scaling enable/disable setting	1: Disable		
	CH1 Scaling upper limit value	0		
	CH1 Scaling lower limit value	0		0: Enable
	CH2 Scaling enable/disable setting	1: Disable		1: Disable

4. In "Basic module parameter", set the values in "CH□ Scaling upper limit value" and "CH□ Scaling lower limit value".

<input checked="" type="checkbox"/>	Scaling function			
	CH1 Scaling enable/disable setting	1: Disable		0: Enable
	CH1 Scaling upper limit value	0		24000
	CH1 Scaling lower limit value	0		0

5. In "Basic module parameter", set "CH□ Digital clipping enable/disable setting" to "0: Enable".

<input checked="" type="checkbox"/>	Digital clipping function			
	CH1 Digital clipping enable/disable setting	1: Disable		
	CH2 Digital clipping enable/disable setting	1: Disable		
	CH3 Digital clipping enable/disable setting	1: Disable		0: Enable
	CH4 Digital clipping enable/disable setting	1: Disable		1: Disable

(4) Example of the combined use of the digital clipping function, the scaling function, and the shift function

Ex. For the channel with the set input range of 0 to 5V, of the main A/D converter module, settings are made as follows:

- "CH□ Scaling enable/disable setting": "0: Enable"
- "CH□ Scaling upper limit value": 12000
- "CH□ Scaling lower limit value": 2000
- "CH□ Digital clipping enable/disable setting": "0: Enable"
- CH□ Shifting amount to conversion value (RWw2 to RWw5): 2000

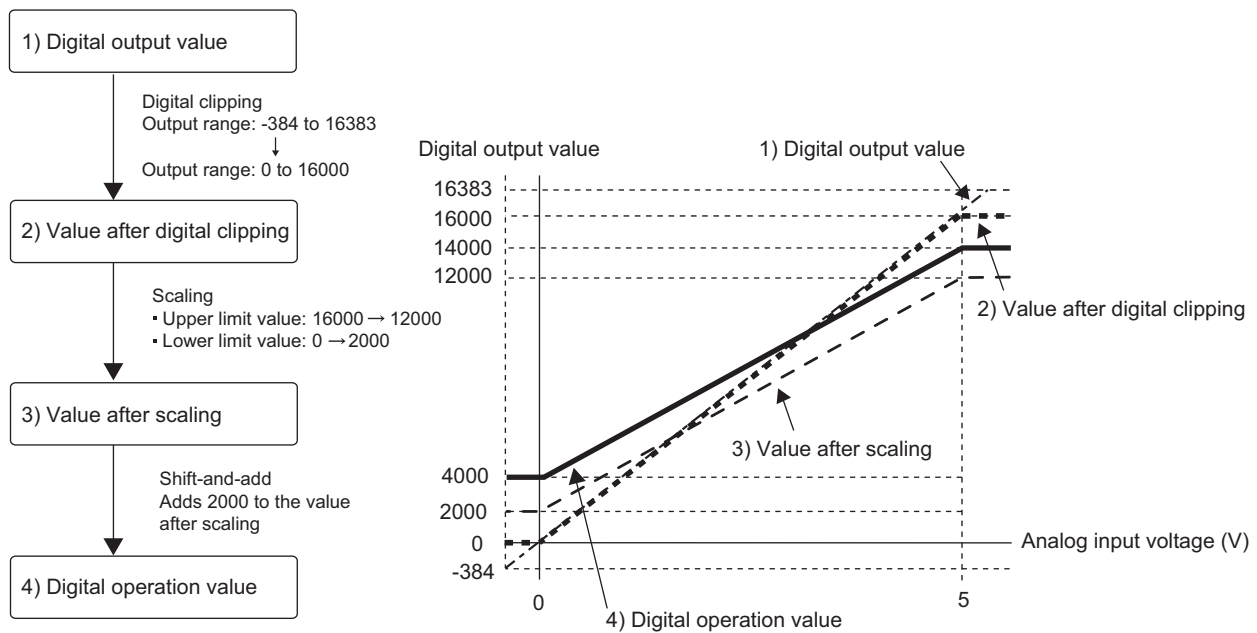

Input voltage (V)	Digital output value	Digital operation value
-0.12	-384	4000
0	0	4000
1	3200	6000
2	6400	8000
3	9600	10000
4	12800	12000
5	16000	14000
5.12	16383	14000

1. Set "Method selection" to "Parameter write".

☞ "CC IE Field Configuration" window ⇒ Select the main A/D converter module from "List of stations"
 ⇒ [CC IE Field Configuration] ⇒ [Online] ⇒ [Parameter Processing of Slave Station]

2. In "Basic module parameter", set "CH□ A/D conversion enable/disable setting" to "0: Enable".

<input checked="" type="checkbox"/>	A/D conversion enable/disable setting		
<input type="checkbox"/>	CH1 A/D conversion enable/disable setting	0: Enable	
<input type="checkbox"/>	CH2 A/D conversion enable/disable setting	0: Enable	
<input type="checkbox"/>	CH3 A/D conversion enable/disable setting	0: Enable	0: Enable
<input type="checkbox"/>	CH4 A/D conversion enable/disable setting	0: Enable	1: Disable

3. In "Basic module parameter", set "CH□ Scaling enable/disable setting" to "0: Enable".

<input checked="" type="checkbox"/>	Scaling function			
	CH1 Scaling enable/disable setting	1: Disable		
	CH1 Scaling upper limit value	0		
	CH1 Scaling lower limit value	0		0: Enable
	CH2 Scaling enable/disable setting	1: Disable		1: Disable

4. In "Basic module parameter", set the values in "CH□ Scaling upper limit value" and "CH□ Scaling lower limit value".

<input checked="" type="checkbox"/>	Scaling function			
	CH1 Scaling enable/disable setting	1: Disable		0: Enable
	CH1 Scaling upper limit value	0		12000
	CH1 Scaling lower limit value	0		2000

5. In "Basic module parameter", set "CH□ Digital clipping enable/disable setting" to "0: Enable".

<input checked="" type="checkbox"/>	Digital clipping function			
	CH1 Digital clipping enable/disable setting	1: Disable		
	CH2 Digital clipping enable/disable setting	1: Disable		
	CH3 Digital clipping enable/disable setting	1: Disable		0: Enable
	CH4 Digital clipping enable/disable setting	1: Disable		1: Disable

6. Set CH□ Shifting amount to conversion value (RWw2 to RWw5) to "2000".

Point 

When the digital clipping function is used with the scaling function, shift function, and difference conversion function, the scale conversion, shift addition, and difference conversion are executed on the value after digital clipping.

8.14 Difference Conversion Function

The digital operation value at the start of this function is treated as "0" (reference value). Thereafter, the difference between the actual digital operation value and the reference value is stored as the digital operation value.

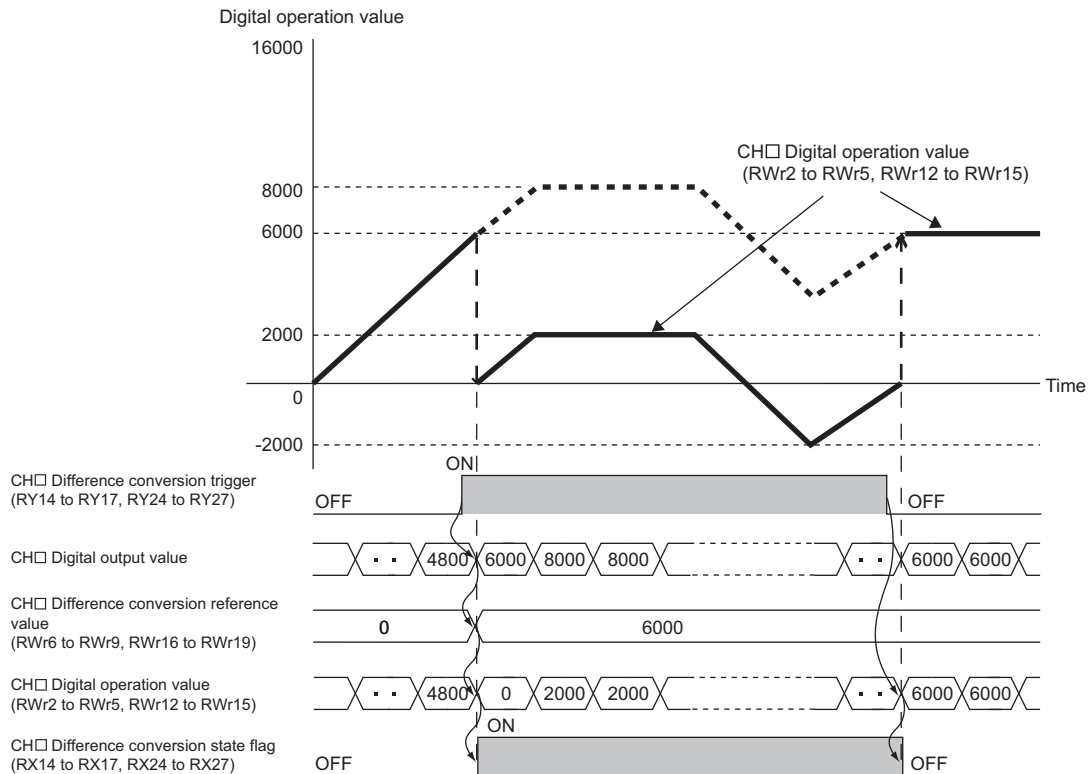

(1) How the difference conversion function

When the difference conversion starts, the digital operation value at that time (the data stored inside the A/D converter module before difference conversion) is determined as the difference conversion reference value. The value acquired by subtracting the difference conversion reference value from the digital operation value is stored in CH□ Digital operation value (RWr2 to RWr5, RWr12 to RWr15). CH□ Digital operation value (RWr2 to RWr5, RWr12 to RWr15) at the start of this function is "0" (because the digital operation value equals to the difference conversion reference value at the start).

$$\text{Digital operation value after difference conversion} = \text{Digital operation value} - \text{Difference conversion reference value}$$

(2) How to use difference conversion

(a) Starting difference conversion

1. Change CH□ Difference conversion trigger (RY14 to RY17, RY24 to RY27) from No request (OFF) to Trigger request (ON).

The rising edge from No request (OFF) to Trigger request (ON) is detected as a trigger. When a trigger is detected, the digital operation value at the starting point is output to CH□ Difference conversion reference value (RWr6 to RWr9, RWr16 to RWr19) and the value obtained by subtracting the difference conversion reference value from the digital operation value is stored in CH□ Digital operation value (RWr2 to RWr5, RWr12 to RWr15). After the storage, CH□ Difference conversion state flag (RX14 to RX17, RX24 to RX27) changes to Converting difference (ON).

(b) Stopping difference conversion

1. Change CH□ Difference conversion trigger (RY14 to RY17, RY24 to RY27) from Trigger request (ON) to No request (OFF).

Change from Trigger request (ON) to No request (OFF) results in the difference conversion stopping and CH□ Difference conversion state flag (RX14 to RX17, RX24 to RX27) changing to Not converted (OFF). After that, the digital output value before difference conversion is stored in CH□ Digital operation value (RWr2 to RWr5, RWr12 to RWr15).

(3) Points for the use of the difference conversion function

(a) Operation when an input signal error occurs

In the event of an input signal error, changing CH□ Difference conversion trigger (RY14 to RY17, RY24 to RY27) from No request (OFF) to Trigger request (ON) does not allow difference conversion to start. After the analog input value returns within the setting range, change CH□ Difference conversion trigger (RY14 to RY17, RY24 to RY27) from No request (OFF) to Trigger request (ON) again. If an input signal error occurs in the status of Trigger request (ON), the difference conversion starts just when the analog input value returns within the setting value, treating the digital output value as the difference conversion reference value.

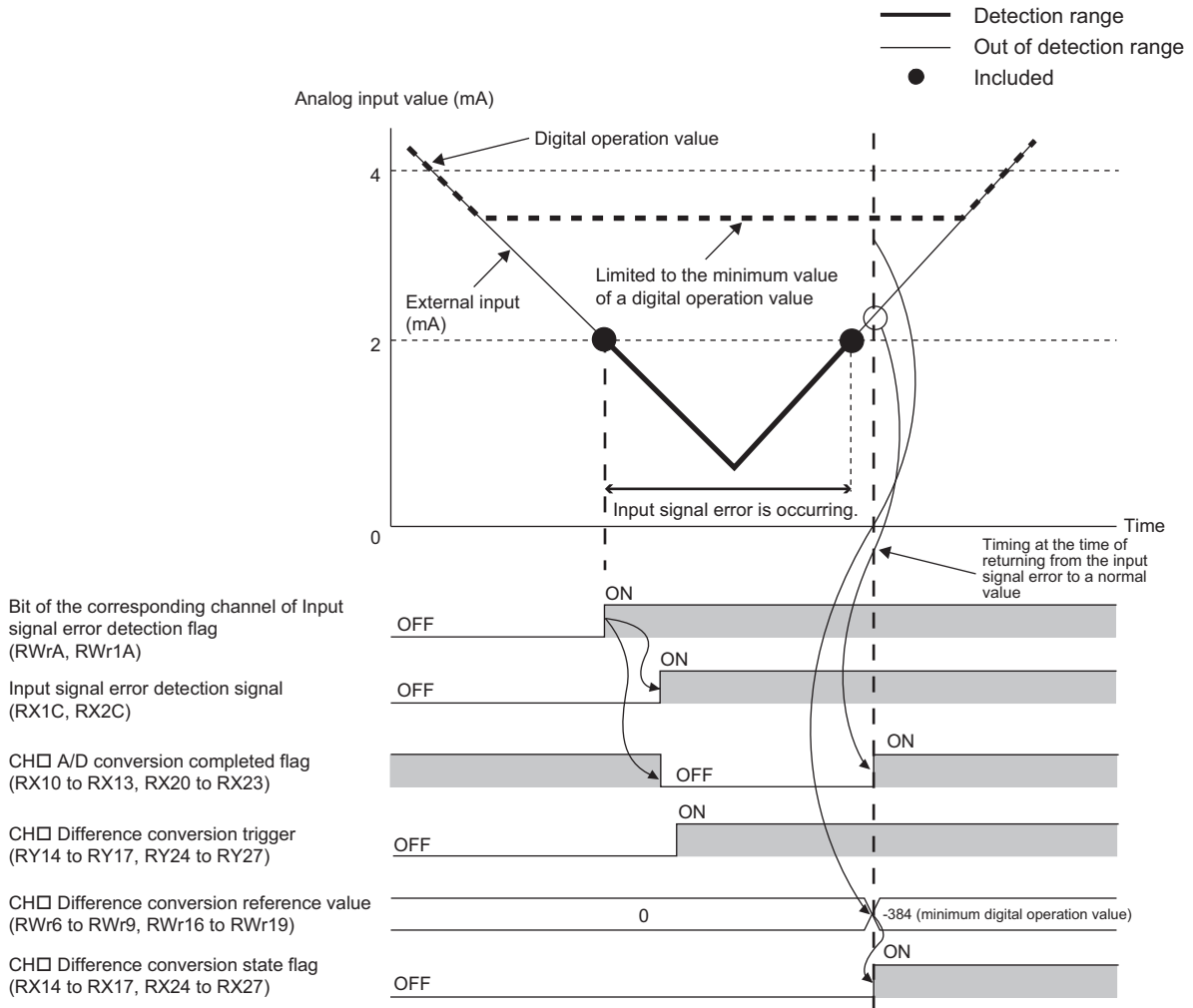

(b) Operation when Initial data setting request flag (RY9) is switched

- During difference conversion, turning on and off Initial data setting request flag (RY9) results in the difference conversion continuing without updating the difference conversion reference value. At this time, even if the digital clipping function, scaling function, and shift function are set valid, the difference conversion reference value is not updated. To update the difference conversion reference value, change CH□ Difference conversion trigger (RY14 to RY17, RY24 to RY27) as follows: Trigger request (ON)→No request (OFF)→Trigger request (ON).

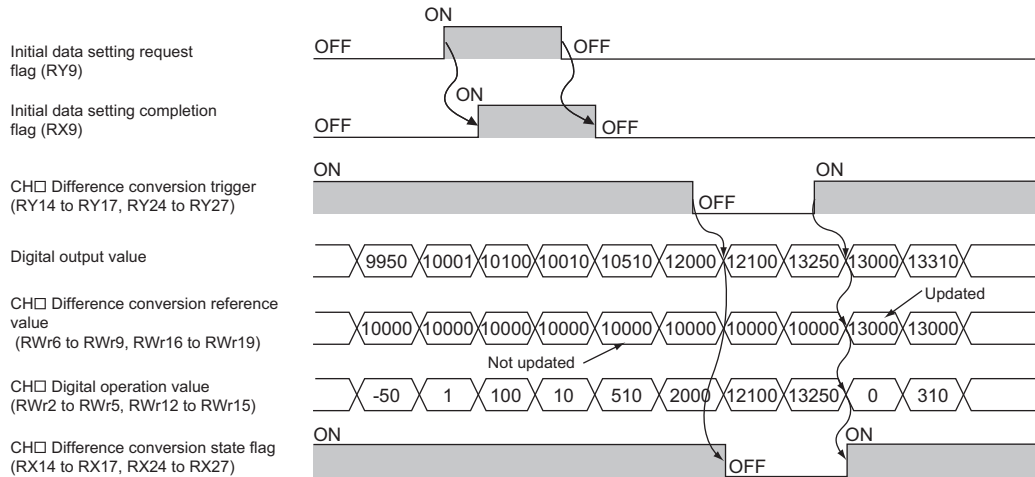

- Before CH□ A/D conversion completed flag (RX10 to RX13, RX20 to RX23) turns on from off by turning on Initial data setting request flag (RY9) from off, changing CH□ Difference conversion trigger (RY14 to RY17, RY24 to RY27) from No request (OFF) to Trigger request (ON) results in operation with the difference conversion reference value taking on the digital operation value at the time when CH□ A/D conversion completed flag (RX10 to RX13, RX20 to RX23) turns on from off.

(c) How the maximum value/minimum value operates

When the difference conversion starts, the maximum value and the minimum value of the values resulting from the difference conversion are stored in Maximum value and Minimum value. Turning on Maximum value/minimum value reset request (RY1D, RY2D) allows the maximum value and the minimum value after the start of the difference conversion to be checked.

Not turning on Maximum value/minimum value reset request (RY1D, RY2D) causes the maximum and minimum values before the difference conversion and the maximum and minimum values after the difference conversion to be mixed up.

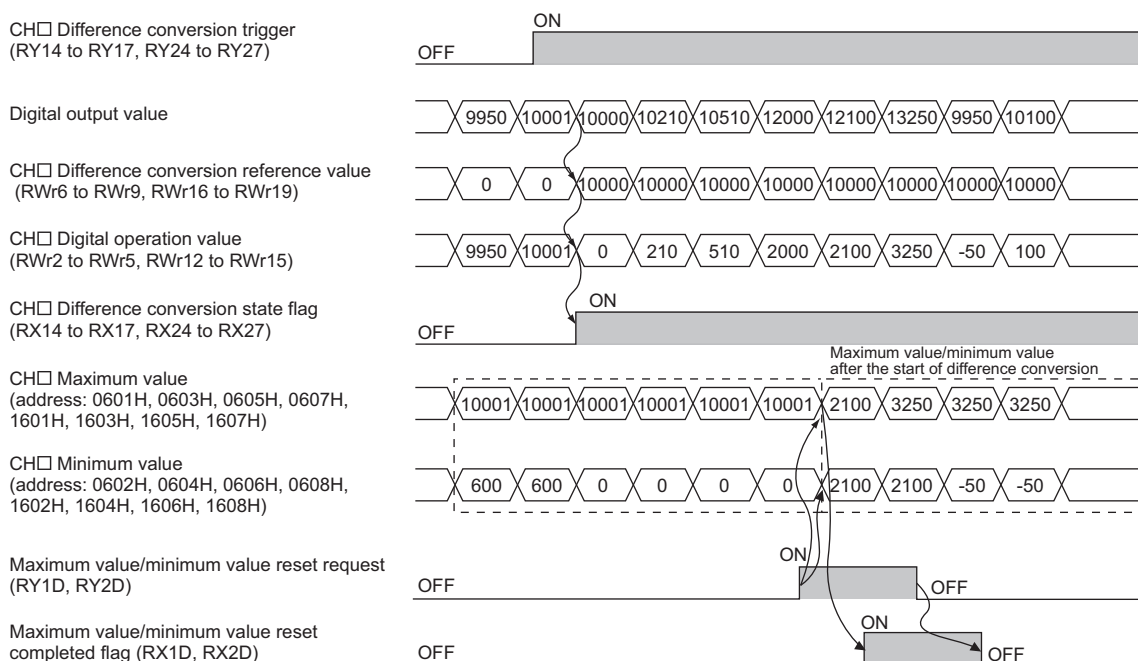

(d) Operation with the averaging processing set

If the difference conversion starts while the averaging processing is set, the digital output value at the completion of the averaging processing is determined as the difference conversion reference value. In addition, CH□ Difference conversion state flag (RX14 to RX17, RX24 to RX27) changes to Converting difference (ON).

Point

- The difference conversion function can be started at any timing.
- When the difference conversion function is used with the digital clipping function, scaling function, and shift function, each processed digital operation value is determined as a difference conversion reference value.

8.15 Trigger Conversion Function

This function provides A/D conversion in accordance with Trigger conversion request that is input.

Point

- This function can be used only when the drive mode is set to trigger conversion mode.
- Every time Trigger conversion request (RY19, RY29) is turned on from off, the A/D converter module performs A/D conversion once for each channel where A/D conversion is enabled.

(1) Combination with the external signal assignment function

In combination with the external signal assignment function, this function initiates A/D conversion by trigger conversion request just at the timing of turning on a remote input signal of an extension input module from off. For the external signal assignment function, refer to the following:

- External Signal Assignment Function ( Page 147, Section 8.18 (2))

Point

An extension input module is required when the trigger conversion function is used with the external signal assignment function.

(2) Restrictions

The following table lists the restrictions on the trigger conversion function.

Function name	Restrictions
Averaging processing	Performs the sampling processing. The setting of "Averaging process setting" will be ignored.
Conversion speed switch function	The conversion speed is determined by the value of "Conversion speed setting" as in the following: <ul style="list-style-type: none">• With "Conversion speed setting" set to a value of 100μs: 100μs/channel• With "Conversion speed setting" set to a value of 400μs or 1ms: 400μs/channel For the conversion timing, refer to the following: <ul style="list-style-type: none">•  Page 129, Section 8.15 (3)
Shift function	Cannot be used. The setting of CH□ Shifting amount to conversion value (RWw2 to RWw5, RWw12 to RWw15) will be ignored.
Difference conversion function	Cannot be used. Turning on CH□ Difference conversion trigger (RY14 to RY17, RY24 to RY27) from off does not allow difference conversion to start.

(3) How the trigger conversion function operates

After setting up the A/D conversion enabled channels and other settings, turning on and off Initial data setting request flag (RY9) results in the module entering the waiting for trigger input state.

Turning on Trigger conversion request (RY19, RY29) from off enables A/D conversion in all the channels where A/D conversion is enabled.

Ex. Operation until Trigger conversion completed flag (RX19) turns on from off after turning on Trigger conversion request (RY19) from off, with the main A/D converter module set to the following conditions:

- "Conversion speed setting": 400 μ s
- A/D conversion enabled: CH1, CH2, CH3, CH4

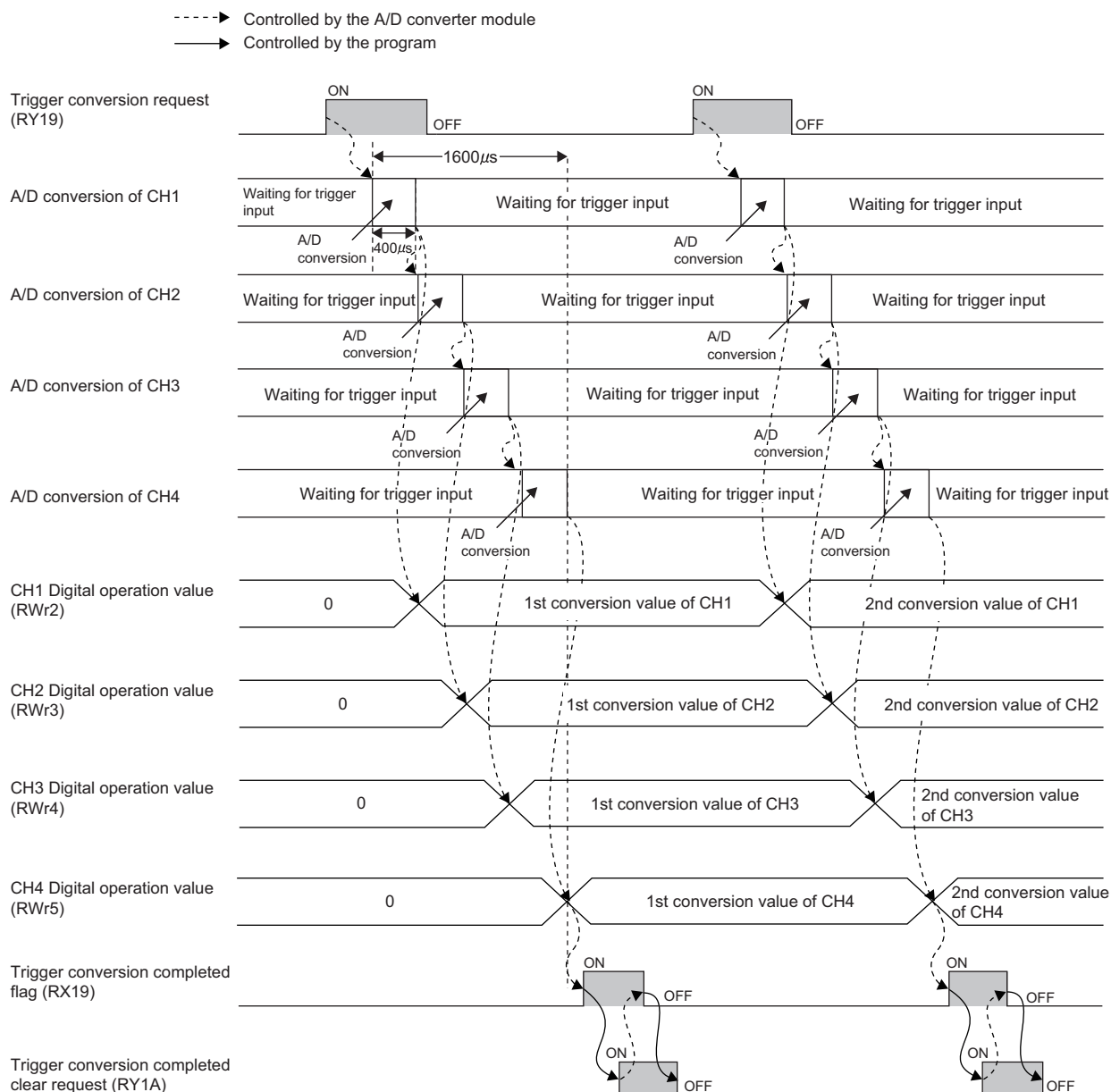

- With the extension A/D converter module connected, processing time (100μs) arises in the period from the completion of conversion processing of each channel to the start of conversion processing of the next channel. Therefore, the conversion time per channel of the main A/D converter module and the extension A/D converter module is given by the following:
 - With the conversion speed switch (address: 0001H) set to 100μs: 100μs + 100μs = 200μs
 - With the conversion speed switch (address: 0001H) set to 400μs: 400μs + 100μs = 500μs
- With the extension D/A converter module connected, the setting of the conversion speed switch (address: 0001H) is ignored, and the conversion speed is fixed to 100μs. In addition, processing time (100μs) arises in the period from the completion of conversion processing of each channel to the start of conversion processing of the next channel. Therefore, the conversion time per channel of the main A/D converter module and the extension D/A converter module is 200μs.

(4) From start to end of trigger conversion

Set Mode switch (address: 0000H) to Trigger conversion mode (1H).

Turning on and off Initial data setting request flag (RY9) results in the error code "0920H" being stored into Latest warning code (RWr1).

Turning off and on the module power supply results in the A/D converter module being in the following state and in the state of waiting for trigger conversion input:

- Trigger conversion completed flag (RX19, RX29) turns off.
- CH□ A/D conversion completed flag (RX10 to RX13, RX20 to RX23) turns off.

The figure below shows the operation until the completion of A/D conversion after turning on Trigger conversion request (RY19, RY29) from off.

Turning on Trigger conversion request (RY19, RY29) from off allows the A/D converter module to start A/D conversion processing. Once the A/D conversion has been completed, Trigger conversion completed flag (RX19, RX29) turns on from off.

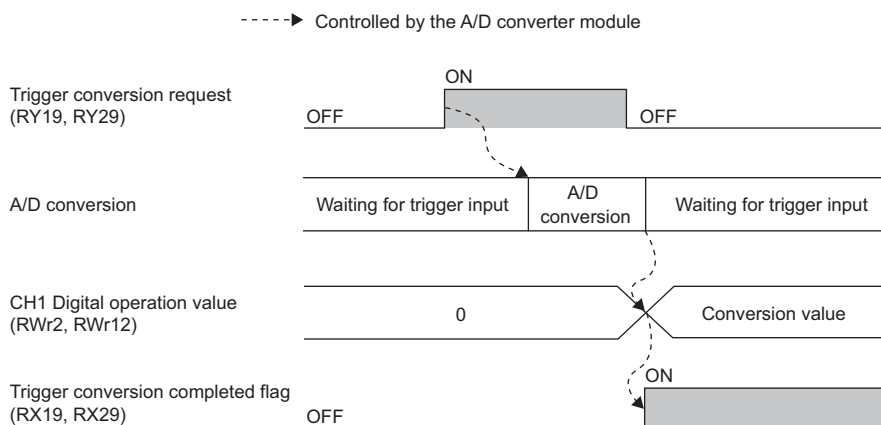

- CH□ A/D conversion completed flag (RX10 to RX13, RX20 to RX23) turns on in order from the channel where A/D conversion has been completed earlier after the start of trigger conversion.
- After that, if the following events occur, CH□ A/D conversion completed flag (RX10 to RX13, RX20 to RX23) turns off:
- Turning on Initial data setting request flag (RY9) from off
 - Detection of an input signal error

(5) About Trigger conversion clear request

The following describes the trigger conversion clear request.

(a) Trigger conversion clear request

The following figure shows the operation where Trigger conversion completed flag (RX19, RX29) turns off from on by turning on Trigger conversion completed clear request (RY1A, RY2A) from off.

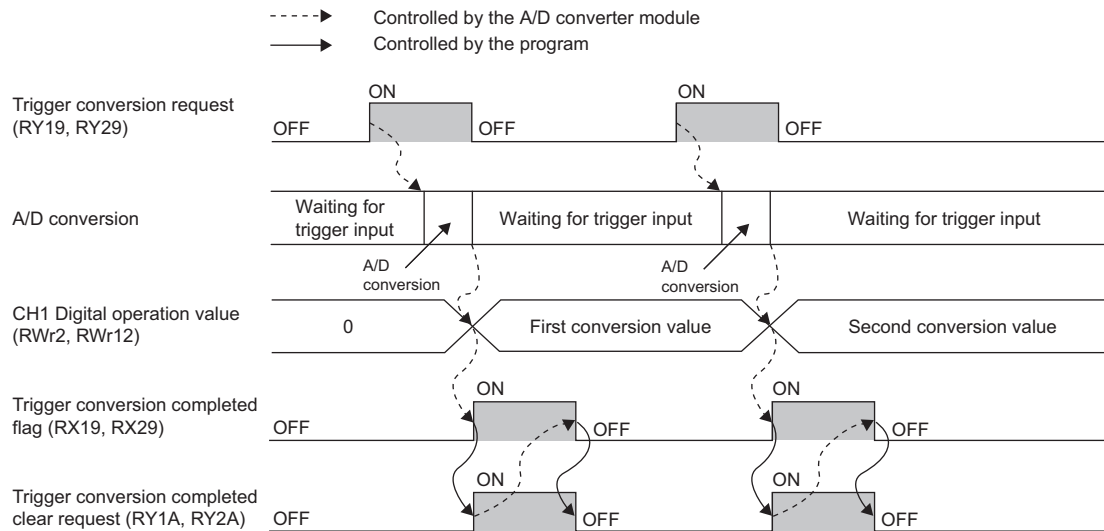

Even while Trigger conversion completed flag (RX19, RX29) is on, turning on Trigger conversion completed clear request (RY1A, RY2A) from off allows the A/D converter module to accept a trigger conversion request and then update the digital operation value.

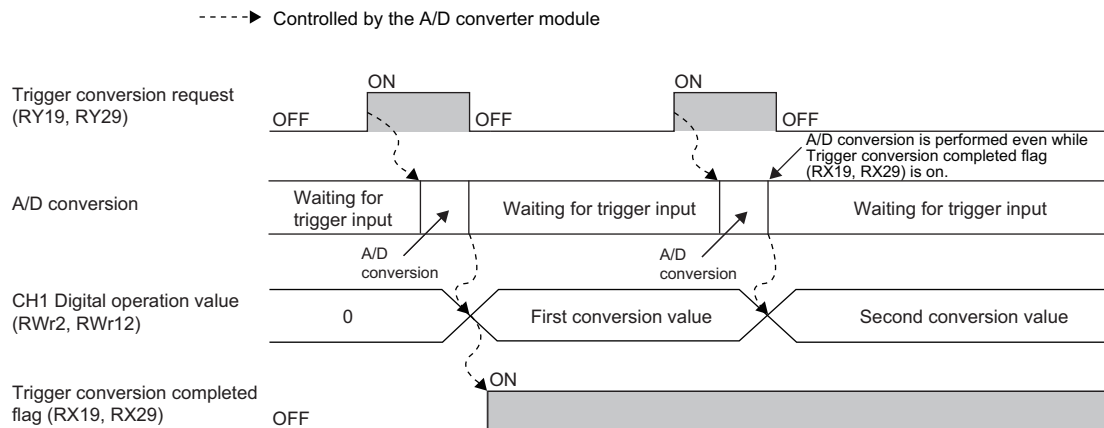

(b) Method for Trigger conversion completed clear request

The time until Trigger conversion completed flag (RX19, RX29) turns off from on by means of Trigger conversion completed clear request (RY1A, RY2A) is influenced by the sequence scan time and the link scan time.

To use Trigger conversion completed flag (RX19, RX29) as an interlock, turn on Trigger conversion request (RY19, RY29) from off after Trigger conversion completed flag (RX19, RX29) turns off from on.

Remark

Turning on Trigger conversion completed clear request (RY1A, RY2A) from off does not clear CH□ A/D conversion completed flag (RX10 to RX13, RX20 to RX23). To clear CH□ A/D conversion completed flag (RX10 to RX13, RX20 to RX23), turn on Initial data setting request flag (RY9) from off.

.....

(6) Response time

The following describes the response time until Trigger conversion completed flag (RX19, RX29) turns on from off after trigger conversion is requested.

(a) When Trigger conversion request (RY19) of the main A/D converter module is assigned to Remote input (RX) using the external signal assignment function

(Response time of the main A/D converter module)^{*1} + (Response time of the extension input module)^{*2} [ms]

*1 The response time of the main A/D converter module is given by the following formulae.

Set value of Conversion speed switch (address: 0001H)	Response time of the main A/D converter module
100μs/channel	Number of A/D conversion enabled channels of the main A/D converter module × 0.1 [ms]
400μs/channel or 1ms/channel	Number of A/D conversion enabled channels of the main A/D converter module × 0.4 [ms]

*2 The response time of the extension input module is the minimum time period from an input of the extension input module until the notification of the input to the main A/D conversion module. This time is given by the following:
(Input response time setting) + 0.5 [ms]

(b) When Trigger conversion request (RY19, RY29) is not assigned to Remote input (RX) using the external signal assignment function

SM^{*1} + LS^{*2} + (Response time of the A/D converter module)^{*3} [ms]

*1 SM: Sequence scan time [ms] (📖 User's manual for the CPU module used in the master station)

*2 LS: Link scan time [ms] (📖 User's manual for the master/local module used)

*3 The response time of the A/D converter module is calculated as shown below.

Set value of Conversion speed switch (address: 0001H)	Presence or absence of an extension analog module	A/D converter module response time
100μs/channel	Absent	Response time of the main A/D converter module: Number of A/D conversion enabled channels of the main A/D converter module × 0.1 [ms]
	Present	Response time of the main A/D converter module: Number of A/D conversion enabled channels of the main A/D converter module × 0.2 [ms] Response time of the extension A/D converter module: Number of A/D conversion enabled channels of the extension A/D converter module × 0.2 [ms]
400μs/channel or 1ms/channel	Absent	Response time of the main A/D converter module: Number of A/D conversion enabled channels of the main A/D converter module × 0.4 [ms]
	Present	Response time of the main A/D converter module: Number of A/D conversion enabled channels of the main A/D converter module × 0.5 [ms] Response time of the extension A/D converter module: Number of A/D conversion enabled channels of the extension A/D converter module × 0.5 [ms]

(7) Input interval and ON and OFF time of Trigger conversion request

When turning on Trigger conversion request from off, the ON/OFF operation of Trigger conversion request should satisfy the reference values of the following items:

- Input interval of Trigger conversion request
- ON time of Trigger conversion request
- OFF time of Trigger conversion request

(a) When Trigger conversion request (RY19) of the main A/D converter module is assigned to Remote input (RX) using the external signal assignment function

The following table lists the input interval, ON time, and OFF time of Remote input (RX) to which Trigger conversion request (RY19) is assigned.

Item	Reference value
Input interval of the trigger conversion request	(Response time of the extension input module) ^{*1} [ms] or longer
ON time of the trigger conversion request	
OFF time of the trigger conversion request	

- *1 The response time of the extension input module is the minimum time period from an input of the extension input module until the notification of the input to the main A/D conversion module. This time is given by the following:
(Input response time setting) + 0.5 [ms]

(b) When Trigger conversion request (RY19, RY29) is not assigned to Remote input (RX) using the external signal assignment function

The following table shows the input interval, ON time, and OFF time of Trigger conversion request (RY19, RY29).

Item	Reference value
Input interval of the trigger conversion request	$SM^{*1} + LS^{*2} + T^{*3}$ [ms]
ON time of the trigger conversion request	
OFF time of the trigger conversion request	

*1 SM: Sequence scan time [ms] (User's manual for the CPU module used in the master station)

*2 LS: Link scan time [ms] (User's manual for the master/local module used)

*3 T takes on the following values:

Set value of Conversion speed switch (address: 0001H)	Presence or absence of an extension analog module	Value of T
100μs/channel	Absent	0.2
	Present	0.3
400μs/channel or 1ms/channel	Absent	0.2
	Present	0.6

-----> Controlled by the A/D converter module

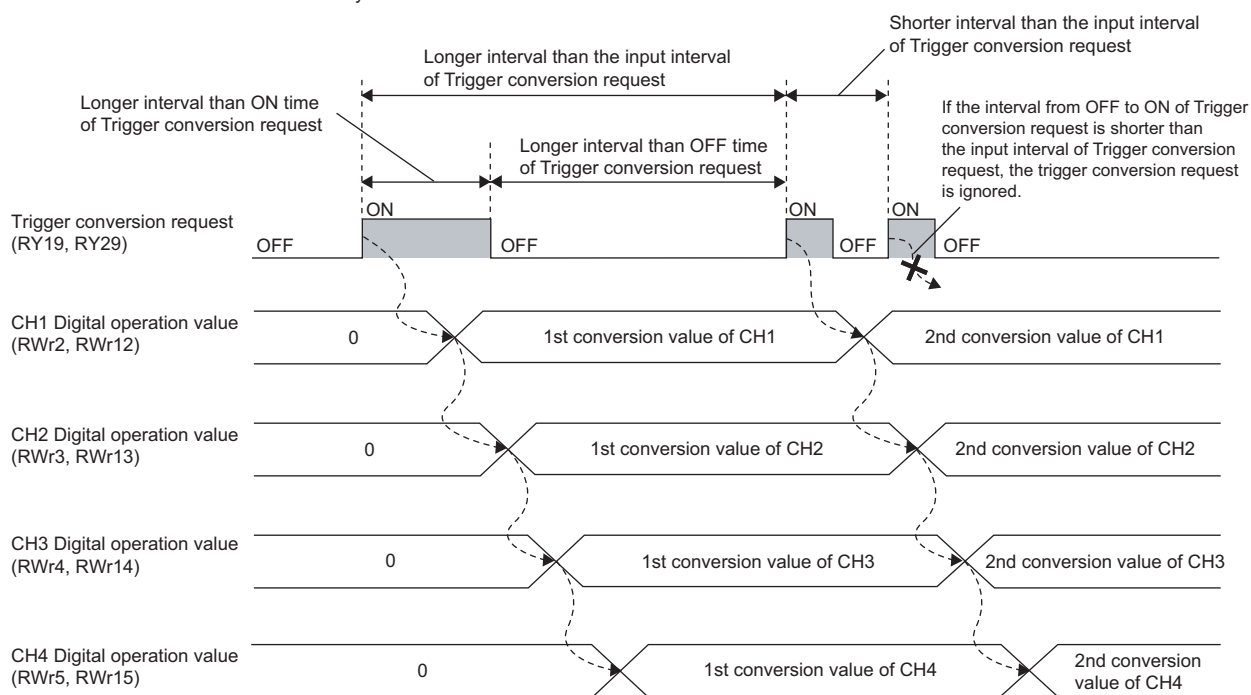

(8) Setting procedure

1. Set "Method selection" to "Parameter write".

 "CC IE Field Configuration" window ⇒ Select a main A/D converter module from "List of stations" ⇒ [CC IE Field Configuration] ⇒ [Online] ⇒ [Parameter Processing of Slave Station]

2. In "Station parameter", set "Mode switch" to "1: Trigger conversion mode".

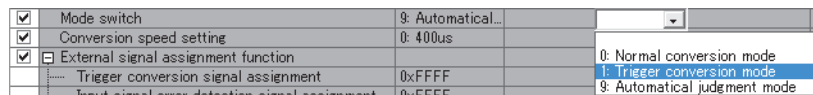

3. In "Basic module parameter", set "CH□ A/D conversion enable/disable setting" to "0: Enable".

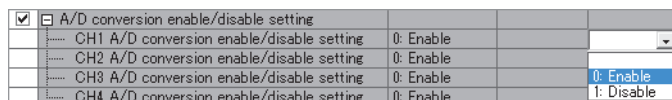

4. Click button to write the parameters to the A/D converter module.

5. Check that "0920H" is stored in Latest warning code (RW1).

 [Online] ⇒ [Monitor] ⇒ [Device/Buffer Memory Batch]

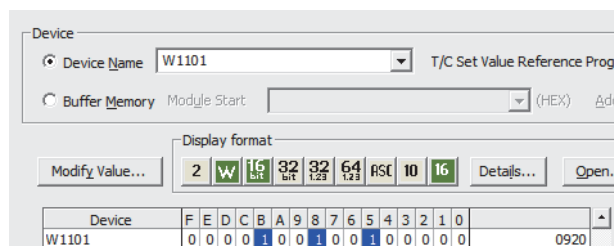

6. Turn off and on the module power supply or perform the remote reset to switch the A/D converter module to trigger conversion mode.

Point

For the extension A/D converter module, make the settings for each item of "Ext. module 1_Module parameter".

8.16 CC-Link IE Field Network Synchronous Communication Function

This function performs A/D conversion with a synchronization period of the master station that supports the CC-Link IE Field Network synchronous communication function.

This enables the A/D converter module to operate at the same timing of other slave stations on the same network.

(1) Supported versions of the modules and software

The table below lists modules and software required to use the CC-Link IE Field Network synchronous communication function.

Module and software	Serial number (first five digits)/version of GX Works2
Simple motion module	15092 or later
GX Works2	Version 1.525X or later
RJ71GF11-T2 or RJ71EN71	(no restriction)
GX Works3	Version 1.005F or later

(2) Restrictions

This section describes restrictions to use the CC-Link IE Field Network synchronous communication function.

(a) Restrictions to use this function with other functions

Function name	Restrictions
Averaging processing	Performs the sampling processing. The setting of "Averaging process setting" will be ignored.
Conversion speed switch function	The conversion speed is determined by the value of "Conversion speed setting" as in the following: <ul style="list-style-type: none"> • With "Conversion speed setting" set to a value of 100μs: 100μs/channel • With "Conversion speed setting" set to a value of 400μs or 1ms: 400μs/channel The conversion processing of the A/D converter module synchronizes with the synchronization period set in the master station. For the conversion timing, refer to the following. <ul style="list-style-type: none"> • Page 137, Section 8.16 (3)
Shift function	Cannot be used. The setting of CH□ Shifting amount to conversion value (RWw2 to RWw5, RWw12 to RWw15) will be ignored.
Difference conversion function	Cannot be used. Turning on CH□ Difference conversion trigger (RY14 to RY17, RY24 to RY27) from off does not allow difference conversion to start.
Extension I/O function	The extension I/O module can be used, but input and output of the extension I/O module is not synchronized with the operation cycle of the simple motion module.
Cyclic data update watch function	The setting of Cyclic data update watch time setting (address: 0007H) will be ignored.

(b) Restrictions on the number of A/D conversion enabled channels

There are restrictions on the number of conversion enabled channels for the A/D converter module depending on the settings of the synchronization period of the master station and "Conversion speed setting" of the main A/D converter module. For details, refer to the following:

Page 141, Section 8.16 (4)

(c) Restrictions on the network parameter settings (RWw/RWr)

In the RWw/RWr settings of network parameters, set the network parameters so that RWwF/RWrF are assigned.

(3) How the CC-Link IE Field Network synchronous communication function operates

At every synchronization period of the master station, A/D conversion processing is performed on the A/D conversion enabled channels.

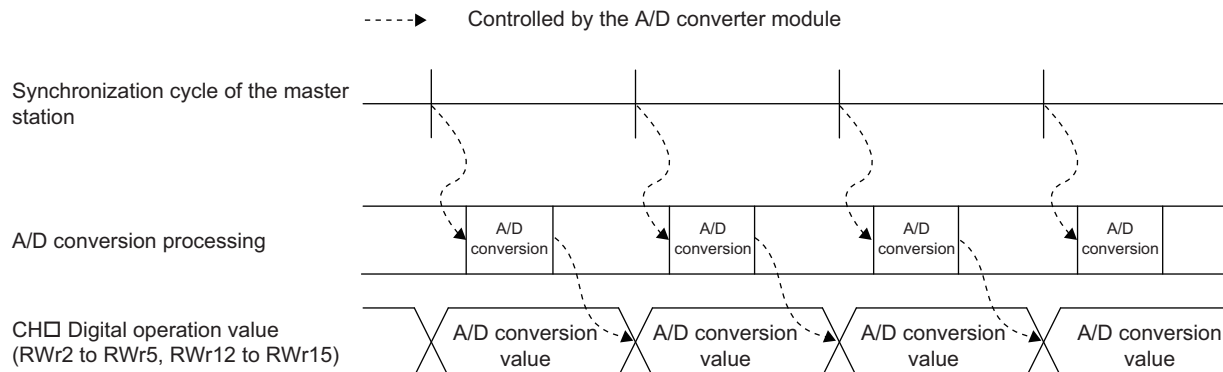

(a) With no extension module connected, or with an extension I/O module connected

The figure below shows the operation timing under the following settings:

- Synchronization period of the master station: 0.88ms
- Conversion speed setting: 100μs
- Number of conversion enabled channels of the main A/D converter module: 4 channels

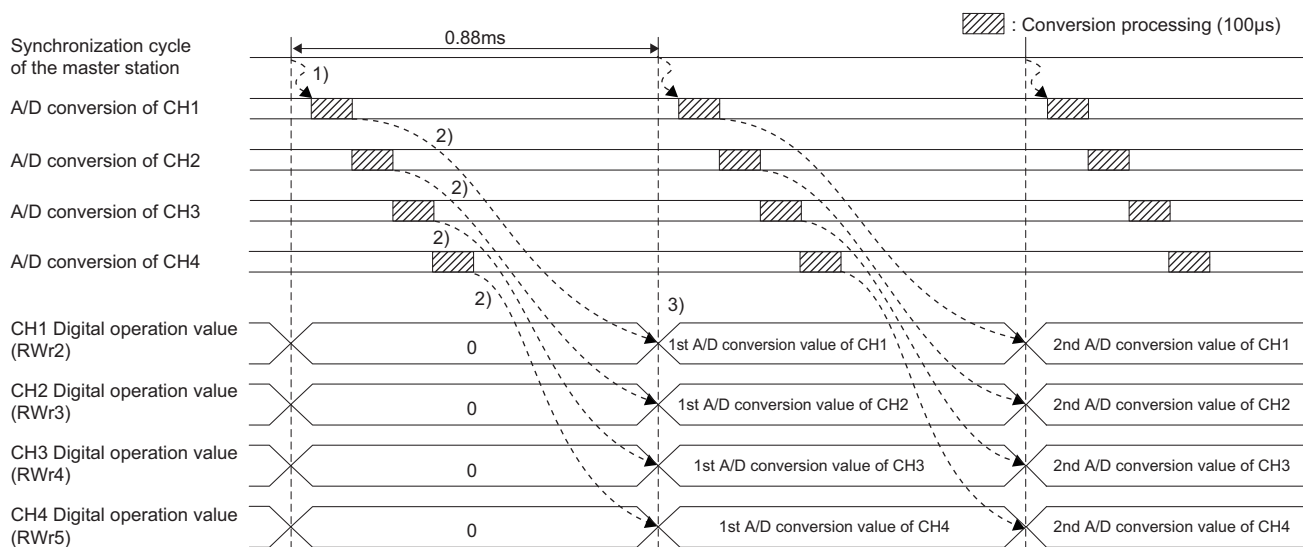

No.	Description
1)	At the starting point of the synchronization period of the master station, A/D conversion starts.
2)	A/D conversion takes place in the order of from CH1 to CH4 at an interval of 100μs.
3)	At the starting point of the synchronization period of the master station, the values after A/D conversion are transferred to the master station.

(b) With the extension A/D converter module connected

At every synchronization period of the master station, A/D conversion processing of the main A/D converter module and A/D conversion processing of the extension A/D converter module take place as in the following:

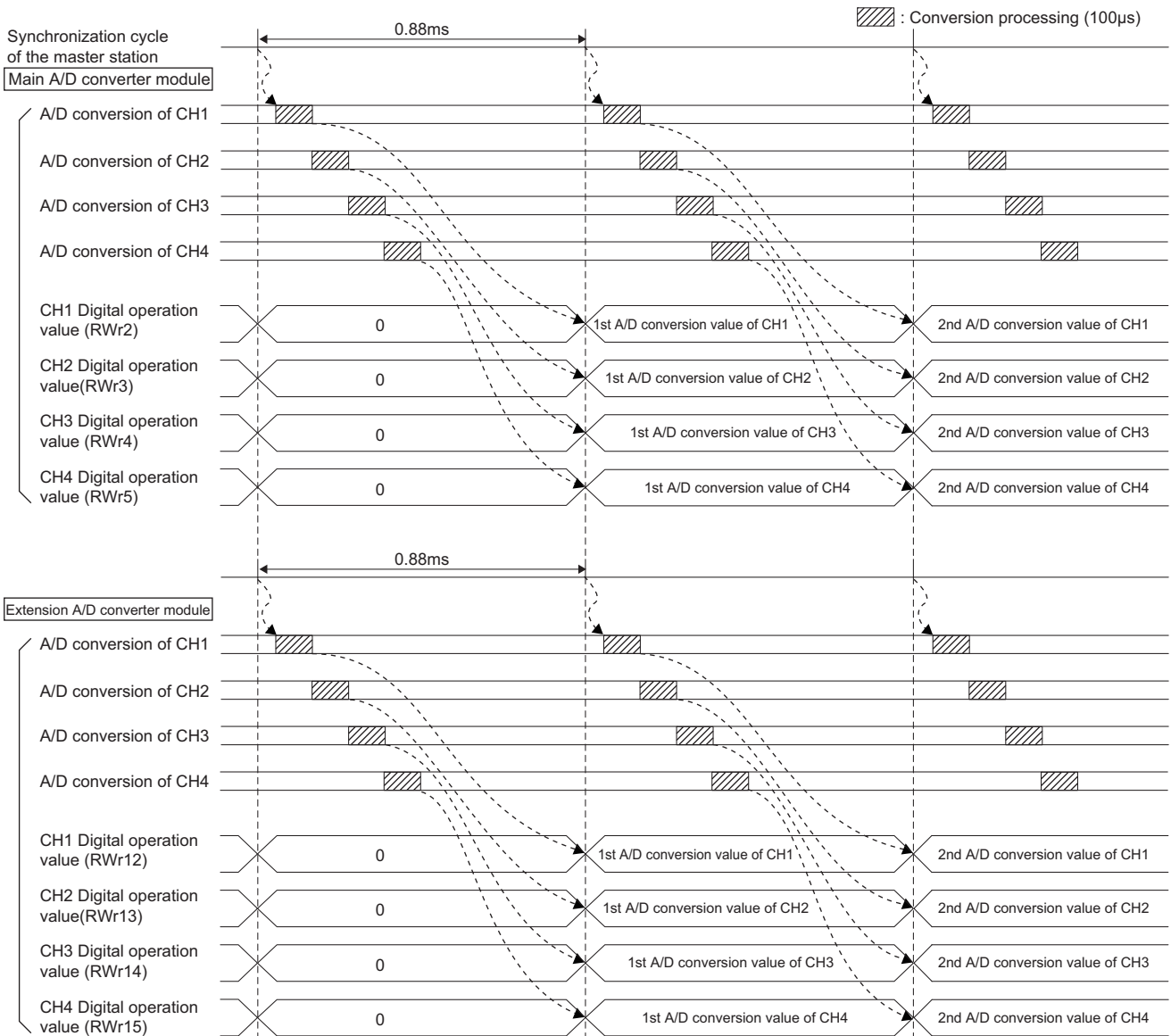

Point

With an extension analog module connected, normal mode or trigger conversion mode involves processing time (100µs) in the period from the completion of conversion processing of each channel to the start of conversion processing of the next channel; however, synchronous communication mode does not involve this processing time.

(c) With the extension D/A converter module connected

At every synchronization period of the master station, A/D conversion processing of the main A/D converter module and D/A conversion processing of the extension D/A converter module take place as in the following:

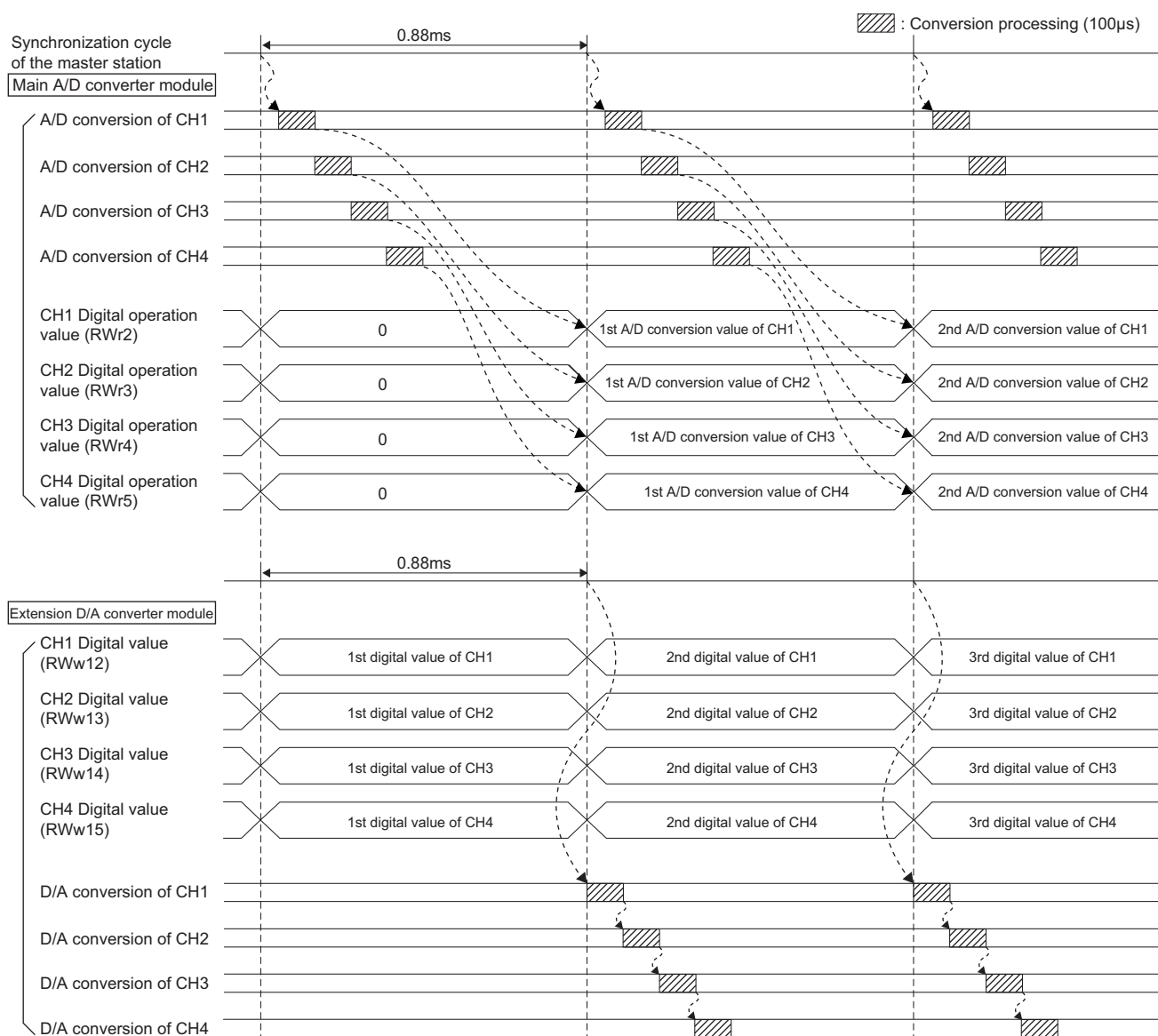
**Point**

- With the extension D/A converter module connected, the conversion speed is fixed to 100µs. The setting of the conversion speed switch (address: 0001H) is ignored.
- With an extension analog module connected, normal mode or trigger conversion mode involves processing time (100µs) in the period from the completion of conversion processing of each channel to the start of conversion processing of the next channel; however, synchronous communication mode does not involve this processing time.

(d) SB/SW signals used with the CC-Link IE Field Network synchronous communication function

To check the operating status of the A/D converter module (synchronous or asynchronous), use the following link special register (SW) on the master station.

- Synchronous/asynchronous operation status information of each station (of master station) (SW01C8 to SW01CF)

For details, refer to the following.

When the master station is RJ71GF11-T2 or RJ71EN71:

-  MELSEC iQ-R CC-Link IE Field Network User's Manual (Application)

When the master station is the simple motion module:

-  MELSEC-Q QD77GF Simple Motion Module User's Manual (Network)

When read digital operation values, use the condition of the above mentioned link special register (SW) (the corresponding bit of the register being on) as an interlock.

The following figure shows the program example for reading CH1 Digital operation value and CH2 Digital operation value of the main A/D converter module with station number 17.

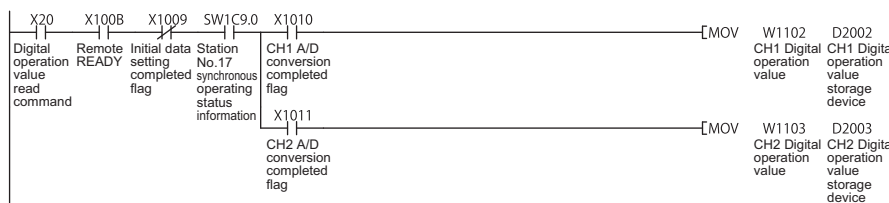

(4) Setting method (master station)

1. Set the synchronization period of the master station to either of the following:

- 0.88ms
- 1.77ms
- 3.55ms

For details on the setting method, refer to the following:

When the master station is RJ71GF11-T2 or RJ71EN71:

 MELSEC iQ-R Inter-Module Synchronization Function Reference Manual

When the master station is the simple motion module:

 MELSEC-Q QD77GF Simple Motion Module User's Manual (Positioning Control)

Point

Set the synchronization period of the master station, and "Conversion speed setting" and the number of conversion enabled channels of the A/D converter modules so that the following conditions are satisfied:

Set value in "Conversion speed setting"	Synchronization period of the master station	Number of conversion enabled channels (maximum)	
		Main A/D converter module	Extension A/D converter module
0: 400μs/channel; or 1: 1ms/channel	0.88ms	1	1
	1.77ms	2	2
	3.55ms	4	4
2: 100μs/channel	<ul style="list-style-type: none"> • 0.88ms • 1.77ms • 3.55ms 	4	4

Setting the number of conversion enabled channels beyond the limits shown above results in the error code (0E40H or 1E40H) being stored in Latest error code (RWr0), Error flag (RXA) turning on, and the ERR. LED turning on, with no A/D conversion performed. In addition, the occurrence of an error (error code: 0E40H or 1E40H) during operation causes the A/D conversion to be interrupted.

(5) Setting procedure (A/D converter module)

1. On the "CC IE Field Configuration" window, select the main A/D converter module from "List of stations", and set the values as follows:
 - When the master station is the simple motion module, set "Station No." to 17 or more.
 - In "RX/Ry Setting", make an assignment of 32 points.
 - In "RWw/RWr Setting", make an assignment of 16 points.
2. Open the "Parameter Processing of Slave Station" window, and set "Method selection" to "Parameter write".

☞ "CC IE Field Configuration" window ⇒ Select the main A/D converter module from "List of stations"
 ⇒ [CC IE Field Configuration] ⇒ [Online] ⇒ [Parameter Processing of Slave Station]

3. In "Station parameter", set "Mode switch" to "9: Automatical judgment mode".

<input checked="" type="checkbox"/>	Mode switch	9: Automatical judgment mode	0: Nor...
<input checked="" type="checkbox"/>	Conversion speed setting	0: 400us	
<input checked="" type="checkbox"/>	External signal assignment function		0: Normal conversion mode
	Trigger conversion signal assignment	0xFFFF	1: Trigger conversion mode
	Input signal error detection signal assignment	0xFFFF	9: Automatical judgment mode

4. In "Basic module parameter", set "CH□ A/D conversion enable/disable setting" to "0: Enable".

<input checked="" type="checkbox"/>	A/D conversion enable/disable setting		
	CH1 A/D conversion enable/disable setting	0: Enable	
	CH2 A/D conversion enable/disable setting	0: Enable	
	CH3 A/D conversion enable/disable setting	0: Enable	0: Enable
	CH4 A/D conversion enable/disable setting	0: Enable	1: Disable

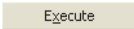
5. Click  button to write the parameters to the A/D converter module.
6. Check that "0920H" is stored in Latest warning code (RWr1).

☞ [Online] ⇒ [Monitor] ⇒ [Device/Buffer Memory Batch]

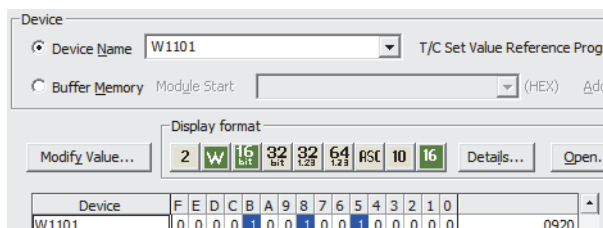

7. Turn off and on the module power supply or perform remote reset to operate the A/D converter module in synchronous communication mode.

Point

For the extension A/D converter module, make the settings for each item of "Ext. module 1_Module parameter".

8.17 Error Notification Function

When an error, warning, or alarm occurs, the A/D converter module notifies the master station of it using remote input signals and remote registers.

Remark

The notification of the error, warning, or alarm can be checked on the LED on the front of the module.

For details, refer to the following:

- PART NAMES ( Page 20, CHAPTER 2)

(1) Notification of an error

The A/D converter module notifies the master station of an error in the following method.

Item	Description	Reference
Error flag (RXA)	Turns on when a moderate error or major error occurs.	Page 192, Appendix 1.1 (3)
Latest error code (RWr0)	An error code is stored when a moderate error or major error occurs.	Page 202, Appendix 2 (1)

Point

For an error occurred in the extension module as well, the occurrence of an error is notified by the ERR. LED, Error flag (RXA), and Latest error code (RWr0) of the main module.

(a) Method for clearing an error

The method for clearing an error depends on the error type.

Error type	Clearing an error
Major error	The error cannot be cleared.
Moderate error	Eliminate the cause of the error and then turn on Error clear request flag (RYA) or Initial data setting request flag (RY9) from off.

(2) Notification of a warning or alarm

The A/D converter module notifies that a warning or alarm occurs to the master station in the following method.

Item	Description	Reference
Warning flag (RX7)	Turns on when a minor error occurs.	Page 190, Appendix 1.1 (1)
Latest warning code (RWr1)	The error code or alarm code is stored when a minor error occurs.	Page 202, Appendix 2 (2)

Point

For an alarm occurred in the extension analog module, the occurrence of an alarm is notified by the ALM LED, Latest warning code (RWr1) of the main analog module.

(a) How to clear a warning or an alarm

The method for clearing an error depends on the error type.

Error type		Clearing an error	
Minor error	Warning	A warning is cleared five seconds after the error cause is removed.*1	
	Alarm	Input signal error detection*2	After the analog input value returns to a value that is larger than the criteria of disconnection detection, turn on Error clear request flag (RYA) or Initial data setting request flag (RY9) from off.
		Alert output	The error is automatically cleared when the digital operation value returns to within the set range between the process alarm upper lower limit value and the process alarm lower upper limit value.

*1 A warning results in the following state five seconds after the error cause is removed.

- Warning flag (RX7) turns off.
- Latest warning code (RWr1) is cleared.
- The ERR. LED turns off.

*2 The error of the input signal error detection is not automatically cleared. Latest warning code (RWr1) is cleared when the other minor errors are cleared while an input signal error occurs.

The warning codes can be checked in the error history on GX Works2. For the error history, refer to the following:

- Checking by executing a command of the slave station (☞ Page 169, Section 11.1 (1))
- Error history data☐ (☞ Page 223, Appendix 3 (23))

Ex. Operation to clear Station number switch changing error (error code: 0940H)

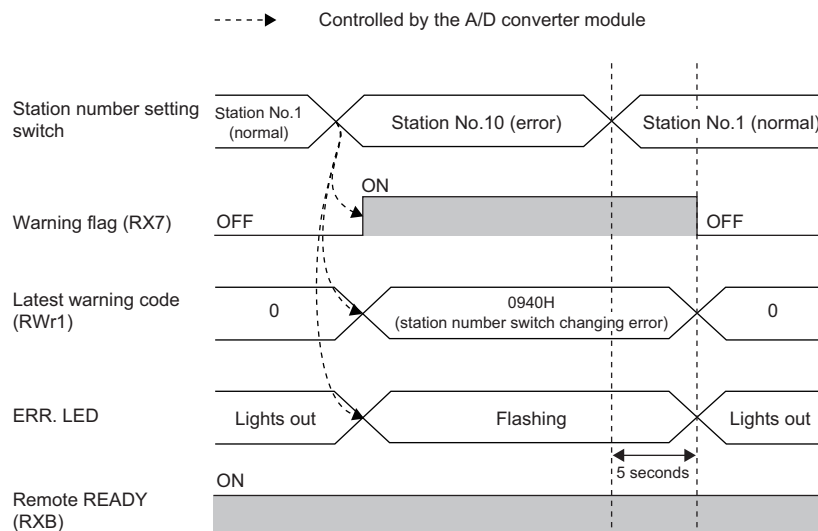

For the method for clearing an alarm, refer to the following:

- Input Signal Error Detection Function (☞ Page 102, Section 8.9)
- Alert Output Function (Process Alarm) (☞ Page 106, Section 8.10)

(3) Method for clearing an error by executing the command of the slave station

The following shows how to clear an error by executing the command of the slave station.

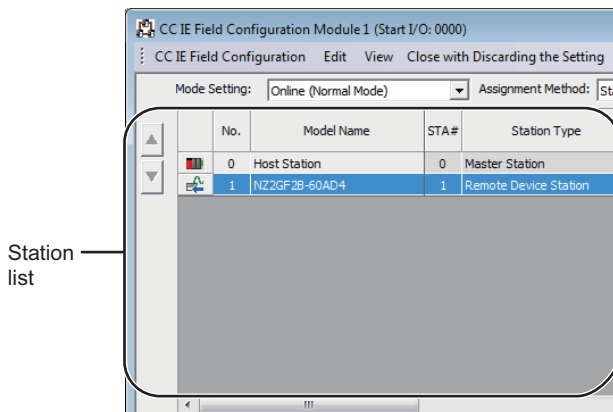



1. On the "CC IE Field Configuration" window, from "List of stations", select the main A/D converter module.

2. Open the "Command Execution of Slave Station" window.

 [CC IE Field Configuration] ⇒ [Online] ⇒ [Command Execution of Slave Station]

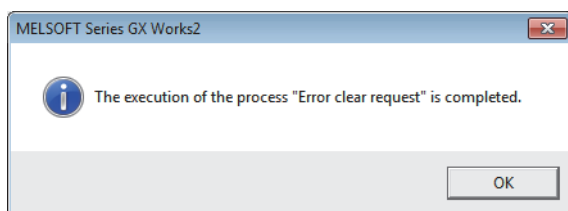
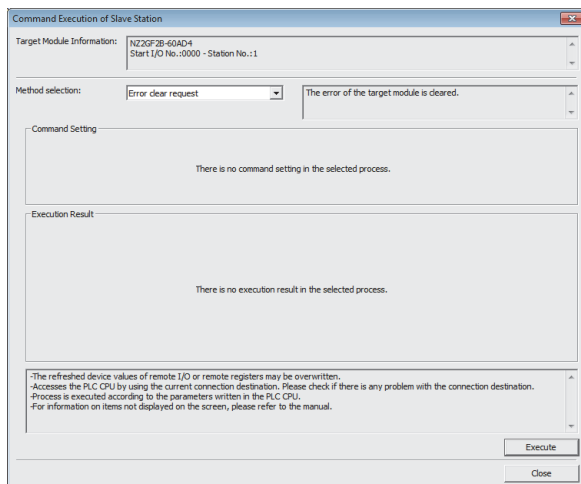
3. Set "Method selection" to "Error clear request" and click  button.



4. In the window that appears (shown left), click  button.

5. The error for the A/D converter module is cleared.

8.18 Functions with an Extension Module Connected

The main A/D converter module permits one extension module to be connected.

Point

- Before replacing the extension module, turn off the module power supply. Disconnecting an extension module during the power-on of the module results in the error code (1F00H) being stored into Latest error code (RWr0), Error flag (RXA) being turned on, and ERR. LED being lit up, which stops the operation.
- After replacing the extension module, write parameters again.

8.18.1 Functions with an extension I/O module connected

Here is the list of the available functions with an extension I/O module connected:

Function	Reference
External power supply monitoring function	Page 146, Section 8.18.1 (1)
External signal assignment function	Page 147, Section 8.18.1 (2)
Digital output HOLD/CLEAR setting function (referred to as the output HOLD/CLEAR setting function in the manual of I/O modules)	CC-Link IE Field Network Remote I/O Module User's Manual
Cyclic data update watch function	
Input response time setting function	
Number of ON times integration function	

(1) External power supply monitoring function

This function monitors the on/off state of the external power supply with the I/O PW LED of an extension output module indicating the state.

By using External power supply monitor request flag (RY1F), a moderate error is generated when the external power supply is off. Thus, the ON/OFF status of the external power supply is notified and the extension output module can be stopped.

(a) External power supply monitoring function

While External power supply monitor request flag (RY1F) is on, power off of the external power supply causes a moderate error to occur. When using this function, check that the external power supply stabilizes before turning on External power supply monitor request flag (RY1F). When turning off the external power supply, turn off External power supply monitor request flag (RY1F) in advance.

(b) Setting and checking the external power supply monitoring function

Item	Description	Reference
External power supply monitor request flag (RY1F)	Set whether to enable or disable the external power supply monitoring function.	Page 201, Appendix 1.2 (7)
External power supply monitor status flag (RX1F)	Indicates whether the external power supply monitoring function is enabled or disabled.	Page 197, Appendix 1.1 (11)

(2) External signal assignment function

This function allows remote input or output signals of the main A/D converter module to be assigned to remote I/O signals of the extension I/O module connected. Signals can be input from the extension I/O module and error signals can be output to the external at the fixed timing without influence from the sequence scan or link scan.

Target remote I/O signal of external signal assignment	Buffer memory to be set
Trigger conversion request (RY19)	"Trigger conversion signal assignment"
Input signal error detection signal (RX1C)	"Input signal error detection signal assignment"
Alert output signal (RX18)	"Alert output signal assignment"
Error flag (RXA)	"Error flag assignment"
Warning flag (RX7)	"Warning flag assignment"

(a) How the external signal assignment function operates

Ex. 1: Assigning Trigger conversion request (RY19) of a main A/D converter module to RX2E of an extension input module

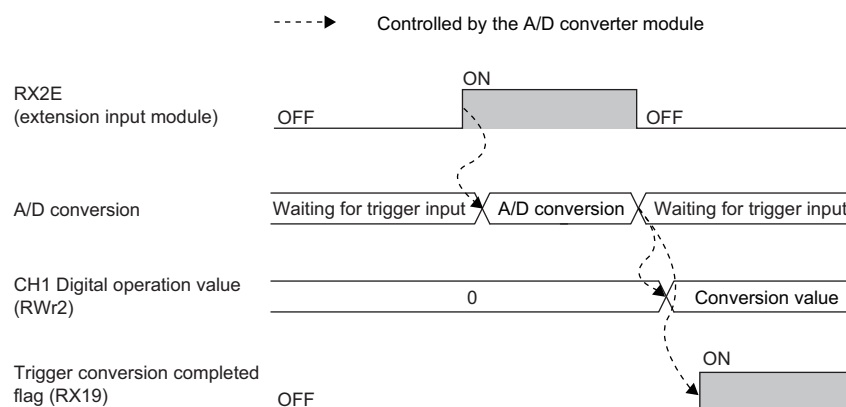
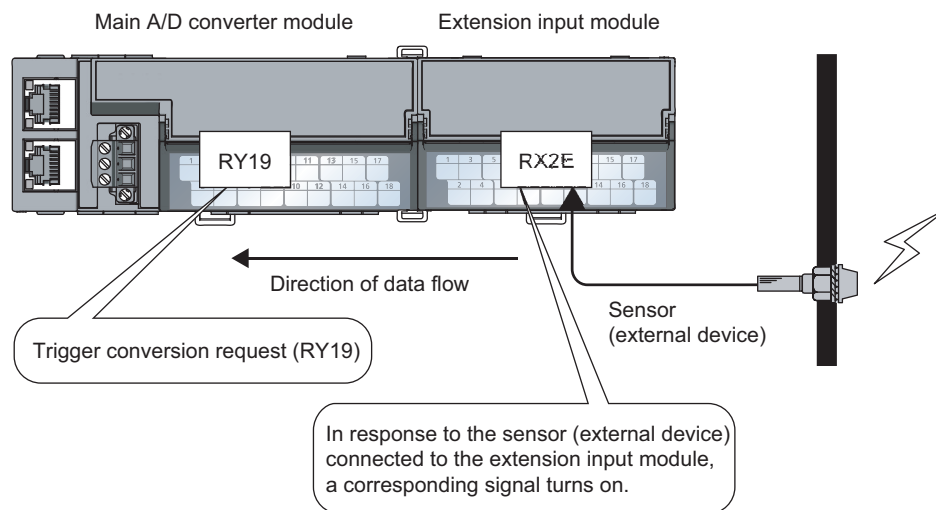

Point

Assigning a remote output signal of the main A/D converter module to a remote input signal of the extension input module does not allow the pre-assigned remote output signal to be turned on/off or monitored by program. Change or monitor the assigned remote input signal of the extension input module. (In the above example, change or monitor RX2E.)

Ex. 2: Assigning Alert output signal (RX18) of a main A/D converter module to RY2A of an extension output module

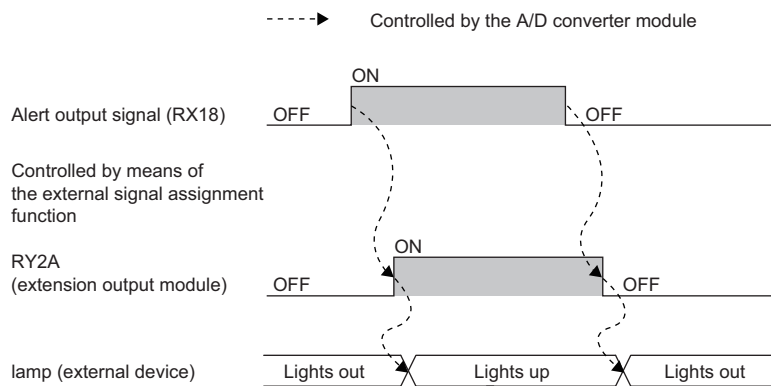
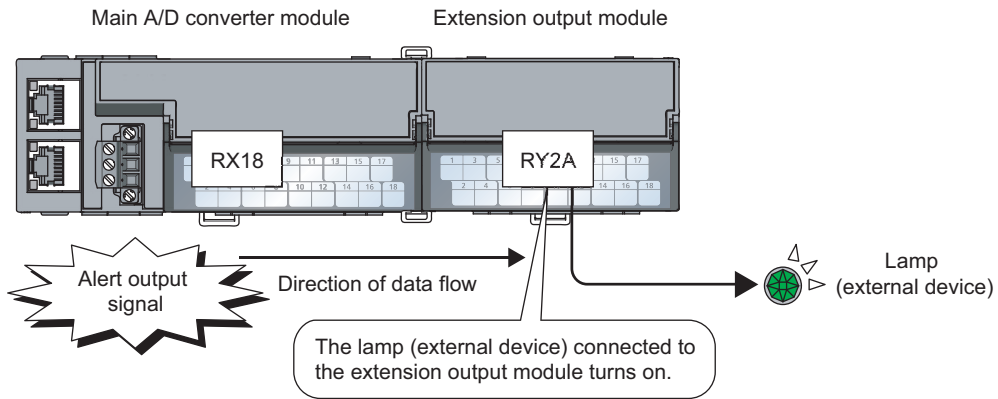

Point

Assigning a remote input signal of the main A/D converter module to a remote output signal of the extension output module does not allow the assigned remote output signal to be turned on/off or monitored by program. Change or monitor the pre-assigned remote input signal of the main module. (In the above example, change or monitor Alert output signal (RX18).)

(b) Setting procedure**1. Set "Method selection" to "Parameter write".**

 "CC IE Field Configuration" window ⇒ Select a main A/D converter module from "List of stations" ⇒ [CC IE Field Configuration] ⇒ [Online] ⇒ [Parameter Processing of Slave Station]

2. In "Basic module parameter", set "CH□ A/D conversion enable/disable setting" to "0: Enable".

<input checked="" type="checkbox"/>	A/D conversion enable/disable setting			
<input type="checkbox"/>	CH1 A/D conversion enable/disable setting	0: Enable		
<input type="checkbox"/>	CH2 A/D conversion enable/disable setting	0: Enable		
<input type="checkbox"/>	CH3 A/D conversion enable/disable setting	0: Enable		0: Enable
<input type="checkbox"/>	CH4 A/D conversion enable/disable setting	0: Enable		1: Disable

3. In "Basic module parameter", set "CH□ Alert output setting" to "0: Enable".

Name	Initial Value	Read Value	Write Value
<input checked="" type="checkbox"/>	Alert output function		
<input type="checkbox"/>	CH1 Alert output setting	1: Disable	
<input type="checkbox"/>	CH1 Process alarm upper upper limit value	0	
<input type="checkbox"/>	CH1 Process alarm upper lower limit value	0	0: Enable
<input type="checkbox"/>	CH1 Process alarm lower upper limit value	0	1: Disable

4. In "Basic module parameter", specify the values for "CH□ Process alarm upper upper limit value", "CH□ Process alarm upper lower limit value", "CH□ Process alarm lower upper limit value", and "CH□ Process alarm lower lower limit value".

Name	Initial Value	Read ...	Write Value
<input checked="" type="checkbox"/>	Alert output function		
<input type="checkbox"/>	CH1 Alert output setting	1: Disable	0: Enable
<input type="checkbox"/>	CH1 Process alarm upper upper limit value	0	16000
<input type="checkbox"/>	CH1 Process alarm upper lower limit value	0	10000
<input type="checkbox"/>	CH1 Process alarm lower upper limit value	0	3000
<input type="checkbox"/>	CH1 Process alarm lower lower limit value	0	0

5. In "Basic module parameter", set "Alert output signal assignment" to 0x002A. (The string 2A is derived from RY2A.)

Name	Initial Value	Read ...	Write Value
<input checked="" type="checkbox"/>	External signal assignment function		
<input type="checkbox"/>	Trigger conversion signal assignment	0xFFFF	
<input type="checkbox"/>	Input signal error detection signal assignme...	0xFFFF	
<input type="checkbox"/>	Alert output signal assignment	0xFFFF	0x002A

Point

- Signals other than remote I/O signals assigned to the external module cannot be set with the external signal assignment function.
Such a setting would result in the error code (017△H) being stored in Latest error code (RWr0), Error flag (RXA) turning on, and the ERR. LED turning on.
- Multiple remote I/O signals of the main module cannot be assigned to a remote output signal of the extension module.
If the above is set, the error code (0180H) is stored in Latest error code (RWr0), Error flag (RXA) turns on, and the ERR. LED turns on.
- The external signal assignment function cannot be used together with the digital output HOLD/CLEAR function.
When "Digital output HOLD/CLEAR setting" is set to "1: HOLD", the setting is ignored and the A/D converter module operates with "0: CLEAR" set.

(c) Operation when an error occurs

Depending on whether the remote I/O signals of the extension I/O module are used as general-purpose I/O signals or assigned for the external signal assignment function, the operation of the A/D converter module for an error differs as shown in the following table.

Remote I/O signal		Remote input (RX)		Remote output (RY)			
Digital output HOLD/CLEAR setting function		—		CLEAR		HOLD	
External signal assignment function		Not assigned	Assigned	Not assigned	Assigned	Not assigned	Assigned* ¹
Status of the A/D converter module	Minor error	Same as the normal operation		Same as the normal operation		Same as the normal operation	
	Moderate error	Clear	Same as the normal operation	Clear	Same as the normal operation	Clear	Same as the normal operation
	Major error	Clear		Clear		Clear	
	In disconnection, or the CPU module being in STOP status	Clear	Same as the normal operation	Clear	Same as the normal operation	Hold* ²	Same as the normal operation

*1 When the external signal assignment function is used, the operation of the A/D converter module is the same as that of when the CLEAR is set for the digital output HOLD/CLEAR setting function, even if HOLD is set.

*2 When "HOLD" is set to Digital output HOLD/CLEAR setting, the Y signal of an extension digital output module is held at the time of disconnection or CPU module STOP.

For different types of errors, the resulting error condition follows the following order of priority:

- Major error > Moderate error > Minor error > In disconnection, or the CPU module being in STOP status

8.18.2 Functions with the extension A/D converter module connected

With the extension A/D converter module connected, A/D conversion processing of up to eight channels is possible.

(1) Available function with the extension A/D converter module connected

Here is the list of the available function with the extension A/D converter module connected:

Function	Description
External power supply monitoring function	Monitors the on/off state of the external power supply of the extension A/D converter module, indicating the monitored state by the RUN LED and External power supply READY flag (RX2F) of the extension A/D converter module. For details, refer to the following: <ul style="list-style-type: none"> External power supply READY flag (Page 198, Appendix 1.1 (12))

(2) Supplementary information related to the connection of the extension A/D converter module

Here is the list of the supplementary information related to the connection of the extension A/D converter module for each drive mode:

Drive mode	Supplementary information related to the connection of the extension A/D converter module	Reference
Normal mode	Processing time (100 μ s) arises in the period from the completion of conversion processing of each channel to the initiation of conversion processing of the next channel.	Page 92, Section 8.5.1 (2)
Trigger conversion mode	Processing time (100 μ s) arises in the period from the completion of conversion processing of each channel to the start of conversion processing of the next channel.	Page 128, Section 8.15

8.18.3 Functions with the extension D/A converter module connected

With the extension D/A converter module connected, A/D conversion processing of four channels and D/A conversion processing of four channels is possible.

(1) Available function with the extension D/A converter module connected

Here is the list of the available function with the extension D/A converter module connected:

Function	Description
External power supply monitoring function	Monitors the on/off state of the external power supply of the extension D/A converter module, indicating the monitored state by the RUN LED and External power supply READY flag (RX2F) of the extension D/A converter module. For details, refer to the following:  CC-Link IE Field Network Digital-Analog Converter Module User's Manual

(2) Supplementary information related to the connection of the extension D/A converter module

Here is the list of the supplementary information related to the connection of the extension D/A converter module for each drive mode:

Drive mode	Supplementary information related to the connection of the extension D/A converter module	Reference
Normal mode	<ul style="list-style-type: none"> The conversion speed is fixed to 100μs. The setting of the conversion speed switch (address: 0001H) is ignored. Processing time (100μs) arises in the period from the completion of conversion processing of each channel to the start of conversion processing of the next channel. 	Page 94, Section 8.5.1 (3)
Trigger conversion mode	<ul style="list-style-type: none"> The extension D/A converter module operates in trigger output mode 	Page 88, Section 8.2 (2)
	<ul style="list-style-type: none"> The conversion speed is fixed to 100μs. The setting of the conversion speed switch (address: 0001H) is ignored. Processing time (100μs) arises in the period from the completion of conversion processing of each channel to the start of conversion processing of the next channel. 	Page 128, Section 8.15
Synchronous communication mode	<ul style="list-style-type: none"> The conversion speed is fixed to 100μs. The setting of the conversion speed switch (address: 0001H) is ignored. 	Page 136, Section 8.16

8.19 CC-Link IE Field Network Diagnostic Function

This function can be used by accessing the engineering tool connected to the CPU module, enabling the detection of a network error.

(1) How to use the function

The following instructions assume the use of GX Works2 as the engineering tool.

1. Establish a connection between GX Works2 and the CPU module.
2. Go to the menu of GX Works2 and start up the CC-Link IE Field Network diagnostics.

 [Diagnostics] ⇒ [CC IE Field Diagnostics]

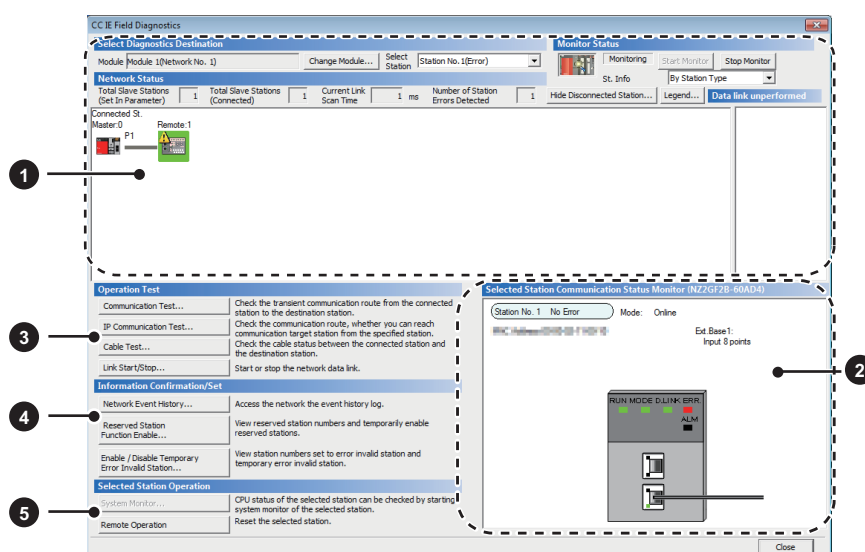

Item to be diagnosed	Description	Reference
① Network configuration and error condition	Allows the condition of the CC-Link IE Field Network to be checked. If an error or a warning occurs in the A/D converter module, an icon appears to show the status of the station.	
② Display of selected-station status and error details	The communication status of the station selected in "Networks Status" can be checked. *1	
③	Communication Test	The transient communication route and whether the communication is established from the connected station to the destination station can be checked.
	IP Communication Test	The reaching time and the route of the IP communication from the connected station to the target station can be checked.
	Cable Test	The cable status between the connected station and the destination station can be checked.
	Link Start/Stop	The network data link can be started and stopped.
④	Network Event History	The history of various events that occurred in the network can be checked.
	Reserved Station Function Enable	A reservation for a station can be temporarily cancelled, and the cancellation can be disabled. Also, the station numbers for the modules set as reserved stations can be checked on a list.
⑤	Enable/Disable Ignore Station Errors	A station not set as an error invalid station can be temporarily set as an error invalid station, and the error invalid station setting can be disabled. Also, the station numbers for the modules set as (temporarily) error ignore stations can be checked on a list.
	System Monitor	The system monitor on the selected station is activated and the status of the module can be checked. This function is unavailable for the A/D converter module.
	Remote Operation	The selected station can be reset through the remote operation.
		User's manual for the master/local module used Page 154, Section 8.19 (1) (a)

- *1 "Selected Station Communication Status Monitor", which appears at the bottom right in the window, indicates the communication status of the main A/D converter module. The model name of the main A/D converter module is displayed as "NZ2GF2B-60AD4" there.
- For how to check the error and alarm of the main A/D converter module and extension A/D converter module, refer to the following:
- How to Check Error Codes and Alarm Codes (📖 Page 169, Section 11.1)

Point

Some master/local module or simple motion module may not support all the diagnostics. For details, refer to the user's manual for the master/local module or the simple motion module used.

- 📖 User's manual for the master/local module used
- 📖 MELSEC-Q QD77GF Simple Motion Module User's Manual (Network)

(a) Remote operation

1. Select the slave station to be reset and click  button.

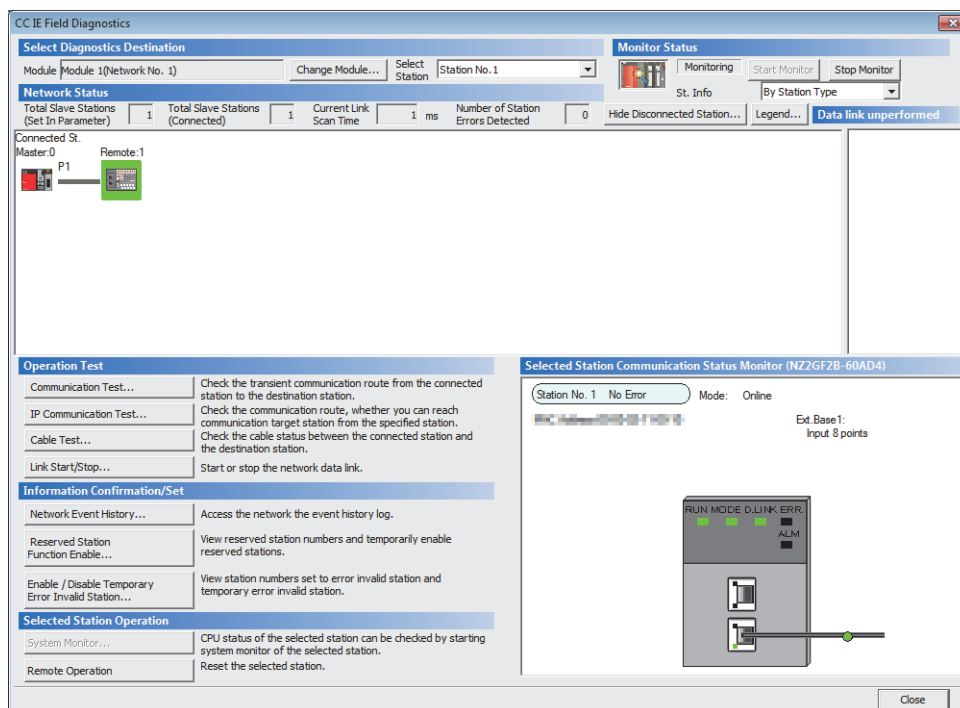

2. In the dialog box that appears (shown below), click  button to start remote reset.

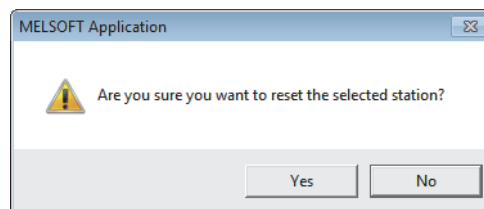

3. In the dialog box that appears (shown below), click  button.

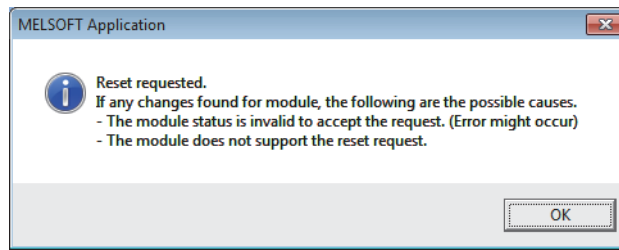

CHAPTER 9 PROGRAMMING

This chapter describes the programming of the A/D converter module.

9.1 Precautions for Programming

This section describes precautions when creating the program of CC-Link IE Field Network.

(1) Program for cyclic transmission

For a program for cyclic transmission, provide interlock between the following link special relay (SB) and the link special register (SW).

- Data link status of the own station (or master station) (SB0049)
- Data link status of each station (SW00B0 to SW00B7)

For the link special relay (SB) and link special register (SW), refer to the following:

User's manual for the master/local module used

Ex. Interlock example

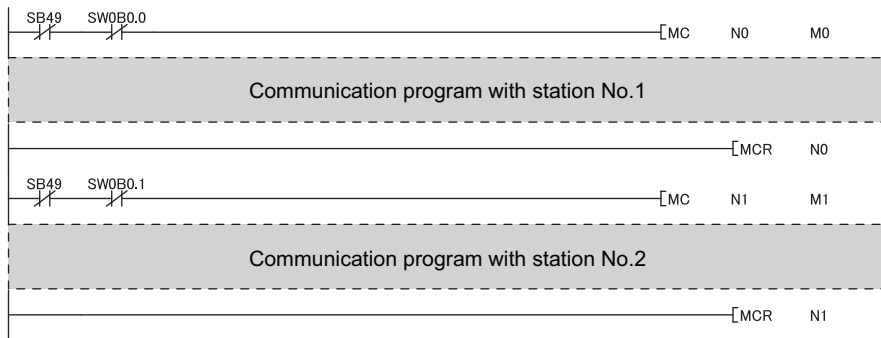

(2) Program for transient transmission

For a program for transient transmission, provide interlock between the following link special relay (SB) and the link special register (SW).

- Baton pass status of the own station (or master station) (SB0047)
- Baton pass status of each station (SW00A0 to SW00A7)

For the link special relay (SB) and link special register (SW), refer to the following:

User's manual for the master/local module used

Ex. Interlock example



9.2 Programming Procedure

Create a program to execute A/D conversion as illustrated by the following procedure.

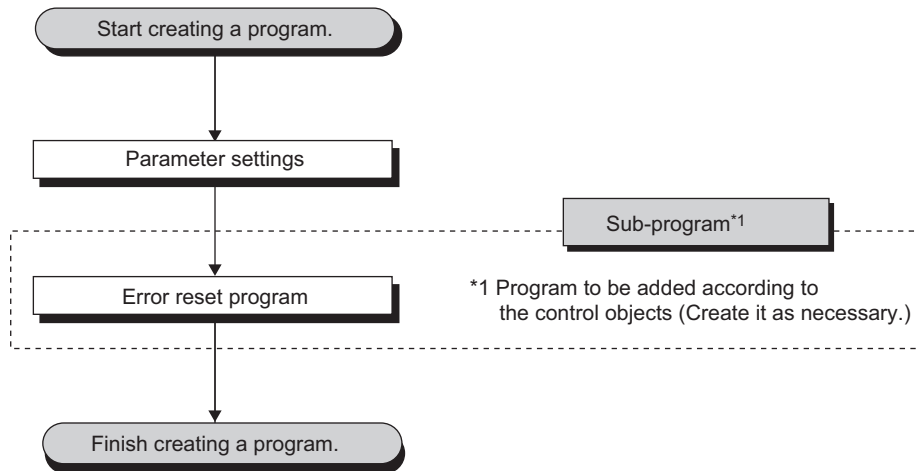

9.3 Program Example

(1) System configuration

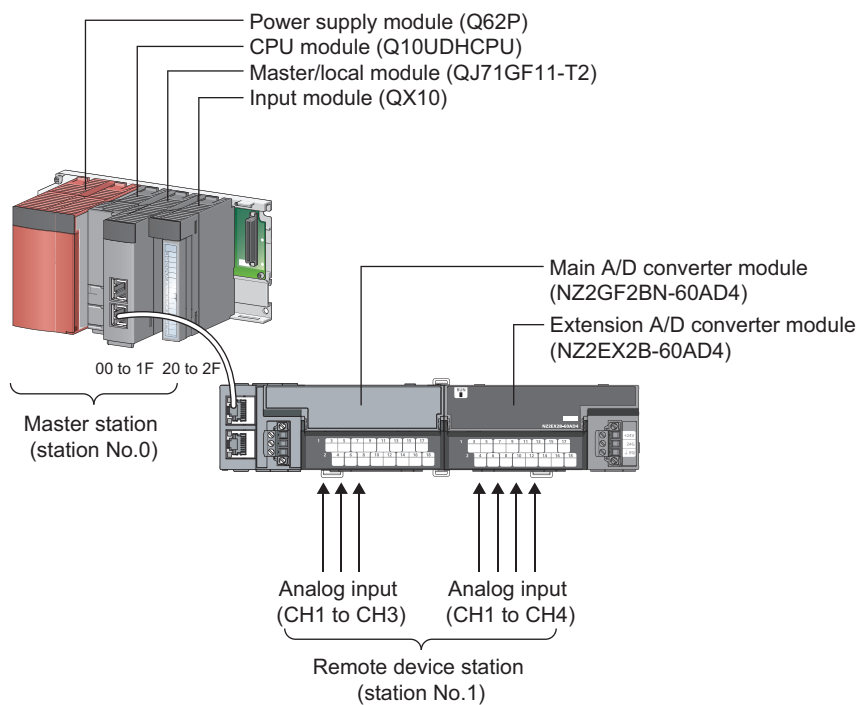

Point

- For the settings using the engineering tool, the procedure is described based on the use of GX Works2.

(a) Assignment of link devices

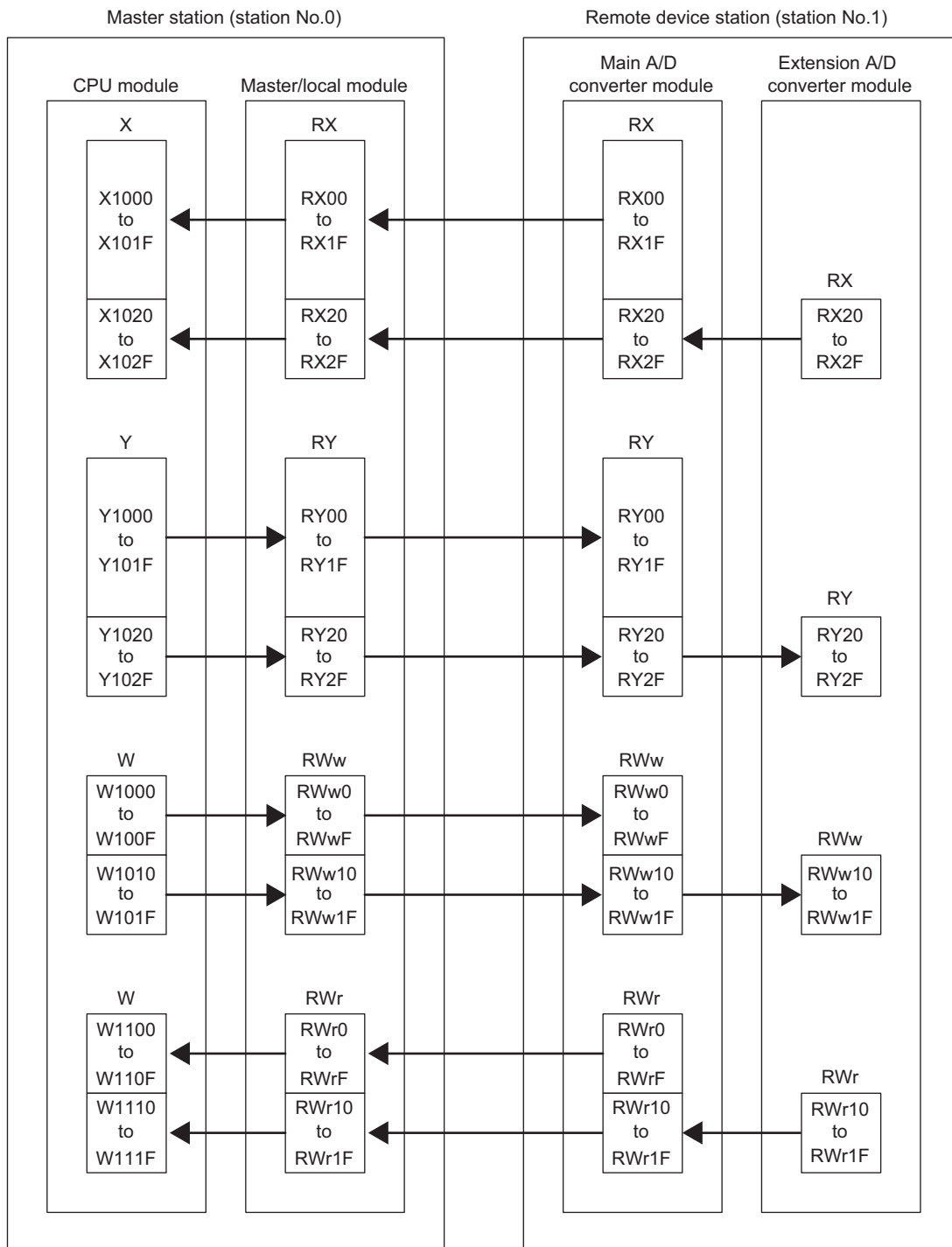

(2) Programming conditions

Here is the programming conditions:

- Digital operation values resulting from A/D conversion of CH1 to CH3 of the main A/D converter module are read out to the master station. A/D conversion takes place at the time of sampling processing for CH1, averaging processing every 50 times for CH2, and every 10 moving averages for CH3.
- Digital operation values resulting from A/D conversion of CH1 to CH4 of the extension A/D converter module are read out to the master station. A/D conversion takes place at the time of sampling processing for CH1 and CH4, averaging processing every 50 times for CH2, and every 10 moving averages for CH3.

(3) Initial settings**(a) Station parameter**

Setting item	Setting value
Conversion speed setting	2: 100 μ s
Cyclic data update watch time setting	5

For the parameters other than the above, use the initial value.

(b) Basic module parameter

Setting item	Setting value
A/D conversion enable/disable setting	CH4 A/D conversion enable/disable setting 1: Disable
Average processing setting	CH2 Averaging process setting 2: Count average
	CH2 Time average/Count average/Moving average 50
	CH3 Averaging process setting 3: Moving average
	CH3 Time average/Count average/Moving average 10
Input signal error detection function	CH1 Input signal error detection setting 4: Disconnection detection
	CH3 Input signal error detection setting 4: Disconnection detection
Alert output function	CH2 Alert output setting 0: Enable
	CH2 Process alarm upper upper limit value 16000
	CH2 Process alarm upper lower limit value 10000
	CH2 Process alarm lower upper limit value 3000
	CH2 Process alarm lower lower limit value 0
Digital clipping function	CH2 Digital clipping enable/disable setting 0: Enable
	CH3 Digital clipping enable/disable setting 0: Enable
Scaling function	CH3 Scaling enable/disable setting 0: Enable
	CH3 Scaling upper limit value 32000
	CH3 Scaling lower limit value 0

For the parameters other than the above, use the initial value.

(c) Ext. module 1_Module parameter

Setting item	Setting value
Ext. module 1_Average processing setting	Ext. module 1_CH2 Averaging process setting 2: Count average
	Ext. module 1_CH2 Time average/Count average/Moving average 50
	Ext. module 1_CH3 Averaging process setting 3: Moving average
	Ext. module 1_CH3 Time average/Count average/Moving average 10
Ext. module 1_Input signal error detection function	Ext. module 1_CH1 Input signal error detection function setting 4: Disconnection detection
Ext. module 1_Alert output function	Ext. module 1_CH2 Alert output setting 0: Enable
	Ext. module 1_CH2 Process alarm upper upper limit value 16000
	Ext. module 1_CH2 Process alarm upper lower limit value 10000
	Ext. module 1_CH2 Process alarm lower upper limit value 3000
	Ext. module 1_CH2 Process alarm lower lower limit value 0
Ext. module 1_Digital clipping function	Ext. module 1_CH1 Digital clipping enable/disable setting 0: Enable
	Ext. module 1_CH2 Digital clipping enable/disable setting 0: Enable
Ext. module 1_Scaling function	Ext. module 1_CH1 Scaling enable/disable setting 0: Enable
	Ext. module 1_CH1 Scaling upper limit value 32000
	Ext. module 1_CH1 Scaling lower limit value 0

For the parameters other than the above, set up the initial value.

(4) Devices used by user

Device	Description	
X20	Main A/D converter module Digital operation value read command	QX10 (X20 to X2F)
X22	Error reset command	
X24	Main A/D converter module Maximum value/minimum value read command	
X26	Main A/D converter module Maximum value/minimum value reset command	
X28	Extension A/D converter module Maximum value/minimum value read command	
X2A	Extension A/D converter module Maximum value/minimum value reset command	
X1007	Warning flag	NZ2GF2BN-60AD4 (RX0 to RX1F)
X1009	Initial data setting completed flag	
X100A	Error flag	
X100B	Remote READY	
X1010	Main A/D converter module CH1 A/D conversion completed flag	
X1011	Main A/D converter module CH2 A/D conversion completed flag	
X1012	Main A/D converter module CH3 A/D conversion completed flag	
X101C	Main A/D converter module Input signal error detection signal	
X101D	Main A/D converter module Maximum value/minimum value reset completed flag	
X1020	Extension A/D converter module CH1 A/D conversion completed flag	
X1021	Extension A/D converter module CH2 A/D conversion completed flag	
X1022	Extension A/D converter module CH3 A/D conversion completed flag	
X1023	Extension A/D converter module CH4 A/D conversion completed flag	
X102C	Extension A/D converter module Input signal error detection signal	
X102D	Extension A/D converter module Maximum value/minimum value reset completed flag	
X102F	External power supply READY flag	NZ2GF2BN-60AD4 (RY0 to RY1F)
Y100A	Error clear request flag	
Y101D	Main A/D converter module Maximum value/minimum value reset request	
Y102D	Extension A/D converter module Maximum value/minimum value reset request	NZ2EX2B-60AD4 (RY20 to RY2F)
W1100	Latest error code	Remote register RWr
W1101	Latest warning code	
W1102	Main A/D converter module CH1 Digital operation value	
W1103	Main A/D converter module CH2 Digital operation value	
W1104	Main A/D converter module CH3 Digital operation value	
W110A	Main A/D converter module Input signal error detection flag	
W110B	Main A/D converter module Alert output flag	
W1112	Extension A/D converter module CH1 Digital operation value	
W1113	Extension A/D converter module CH2 Digital operation value	
W1114	Extension A/D converter module CH3 Digital operation value	
W1115	Extension A/D converter module CH4 Digital operation value	
W111A	Extension A/D converter module Input signal error detection flag	
W111B	Extension A/D converter module Alert output flag	

Device	Description	
D2002	Main A/D converter module CH1 Digital operation value	Device for storage
D2003	Main A/D converter module CH2 Digital operation value	
D2004	Main A/D converter module CH3 Digital operation value	
D2010 to D2015	Main A/D converter module CH1 Maximum value to CH3 Minimum value	
D2020	Main A/D converter module Latest error code	
D2021	Main A/D converter module Latest warning code	
D2022	Main A/D converter module Input signal error detection flag	
D2023	Main A/D converter module Alert output flag	
D2032	Extension A/D converter module CH1 Digital operation value	
D2033	Extension A/D converter module CH2 Digital operation value	
D2034	Extension A/D converter module CH3 Digital operation value	
D2035	Extension A/D converter module CH4 Digital operation value	
D2040 to D2047	Extension A/D converter module CH1 Maximum value to CH4 Minimum value	
D2052	Extension A/D converter module Input signal error detection flag	
D2053	Extension A/D converter module Alert output flag	
F0	Main A/D converter module CH2 upper limit alert issued	
F1	Main A/D converter module CH2 lower limit alert issued	
F2	Main A/D converter module CH1 disconnection occurred	
F3	Main A/D converter module CH3 disconnection occurred	
F4	Main A/D converter module Maximum value/minimum value read completed with an error	
F10	Extension A/D converter module CH2 upper limit alert issued	
F11	Extension A/D converter module CH2 lower limit alert issued	
F12	Extension A/D converter module CH1 disconnection occurred	
F13	Extension A/D converter module Maximum value/minimum value read completed with an error	
M0	Communication ready flag (station number 1)	
M300	Main A/D converter module Maximum value/minimum value read flag	
M310	Main A/D converter module REMFR instruction completed flag	
M311	Main A/D converter module REMFR instruction completed-with-error flag	
M320	Extension A/D converter module Maximum value/minimum value read flag	
M330	Extension A/D converter module REMFR instruction completed flag	
M331	Extension A/D converter module REMFR instruction completed-with-error flag	
SM400	Always ON	
SB47	Baton pass status of own station	
SB49	Data link status of own station (master station)	
SW0A.0	Baton pass status of each station (station number 1)	
SW0B0.0	Data link status of each station (station number 1)	
N0	Nesting (station number 1)	

(5) Setting procedure

Connect GX Works2 to the master station to set up the settings.

1. Create a project on GX Works2.

For "PLC Series", select "QCPU (Q mode)" and for "PLC Type", select "Q10UDH".

 [Project] ⇒ [New...]

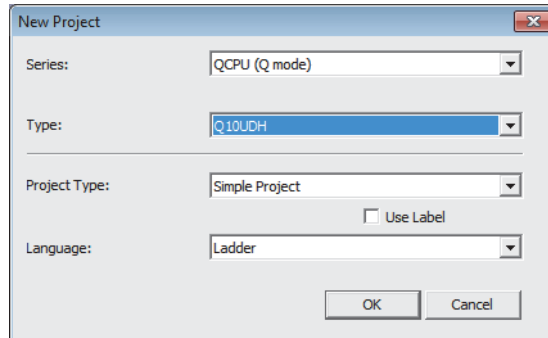

2. Open the network parameter setting window and configure the settings as shown below.

 Project window ⇒ [Parameter] ⇒ [Network Parameter] ⇒ [Ethernet/CC IE/MELSECNET]

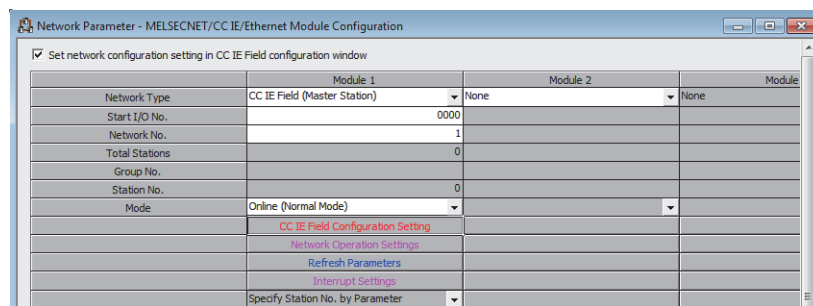

- Open the CC IE Field Configuration window and set up the configuration and station number of a slave station as shown below.

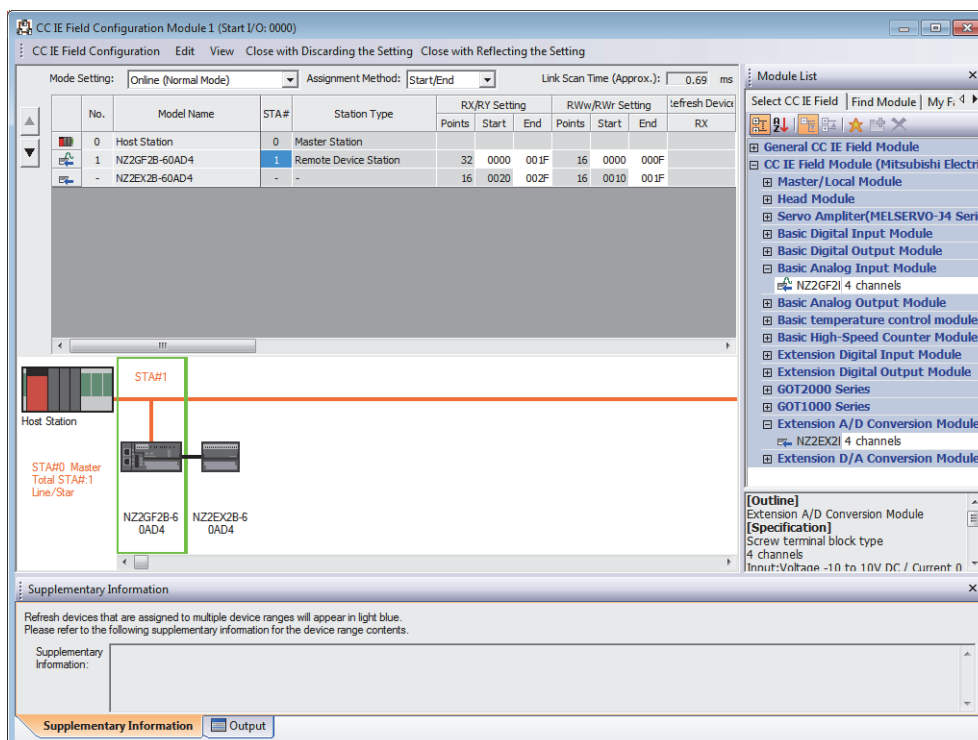

- Close the CC IE Field Configuration window.



- Open the refresh parameter setting window and configure the settings as shown below.

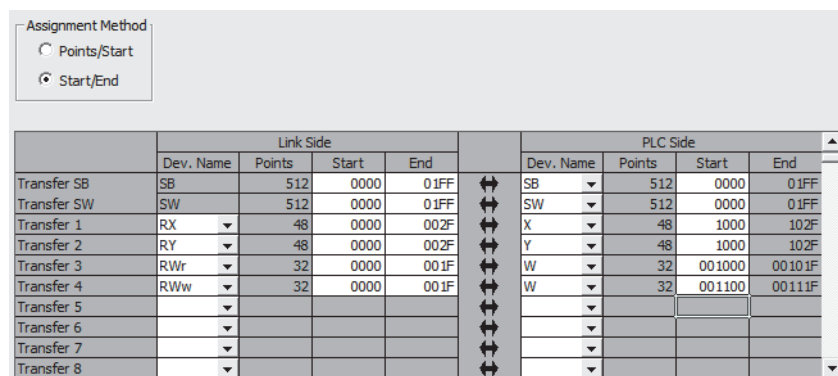

- Write the set parameter to the CPU module of the master station, and reset the CPU module, or turn off and on the power supply.

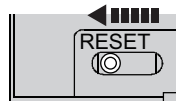
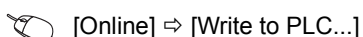

or Power OFF → ON

7. Open the "Parameter Processing of Slave Station" window.

- Project window ⇒ [Parameter] ⇒ [Network Parameter] ⇒ [Ethernet/CC IE/MELSECNET] ⇒ **CC IE Field Configuration Setting** button ⇒ Select the main A/D converter module in "List of stations". ⇒ [CC IE Field Configuration] ⇒ [Online] ⇒ [Parameter Processing of Slave Station]

8. Set "Method selection" to "Parameter write".

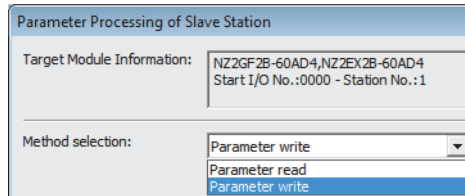

9. Set "Write Value". Follow the next steps to set the value:

- Click the title cell of "Initial Value" to select all the items, and copy them.
- Click the title cell of "Write Value" to select all the items, and paste the copy.
- Select the items to be changed, and set new values as described in Initial settings (Page 159, Section 9.3 (3)).

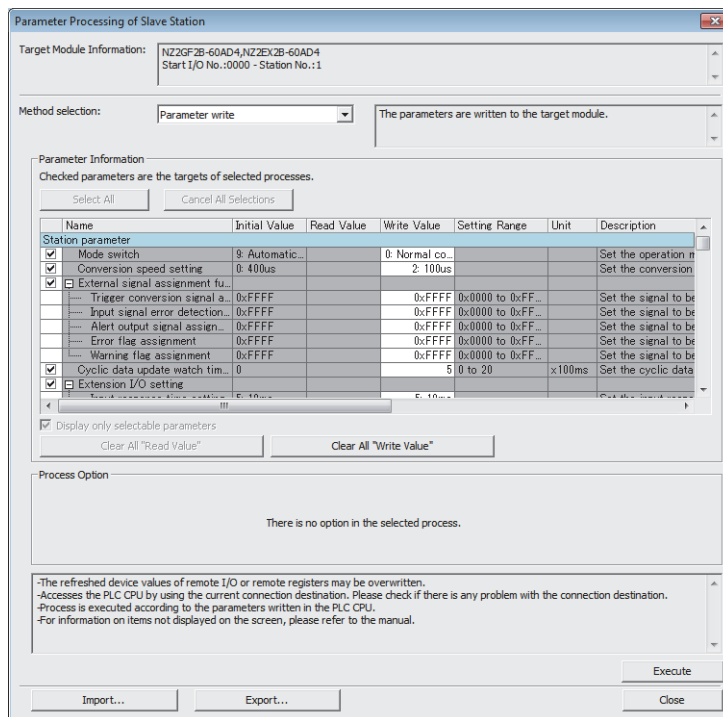

10. Click **Execute button to write the parameters to the A/D converter module.**

(6) Program example

1. Create the following programs with GX Works2.
 - Program for the main A/D converter module

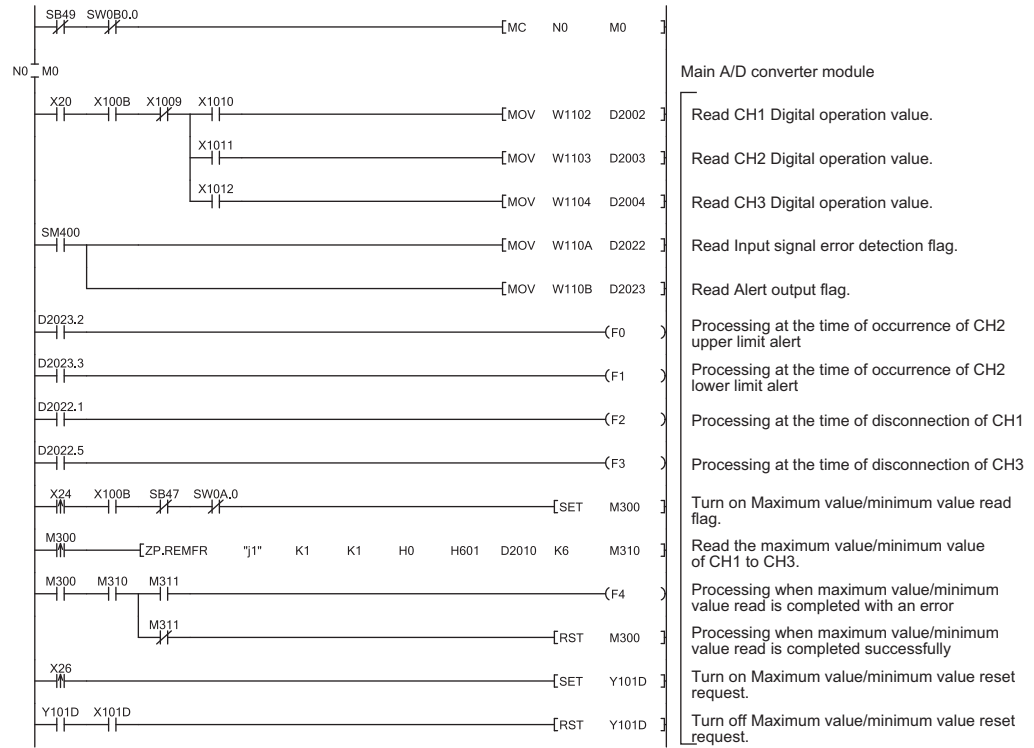

- Program for the extension A/D converter module

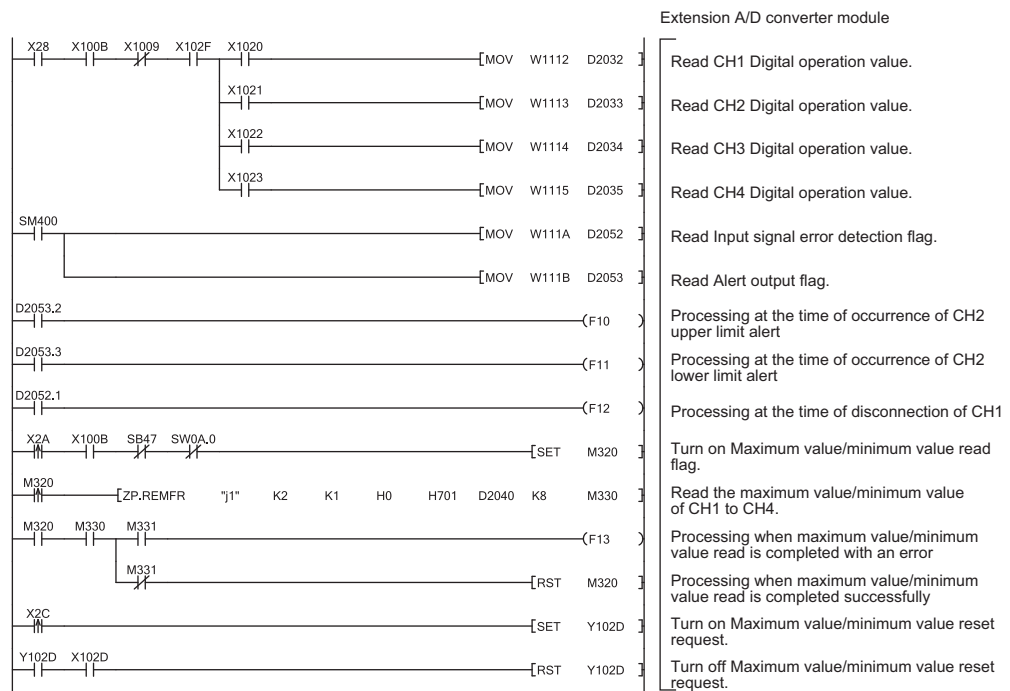

9.3 Program Example

- Program for the common parts

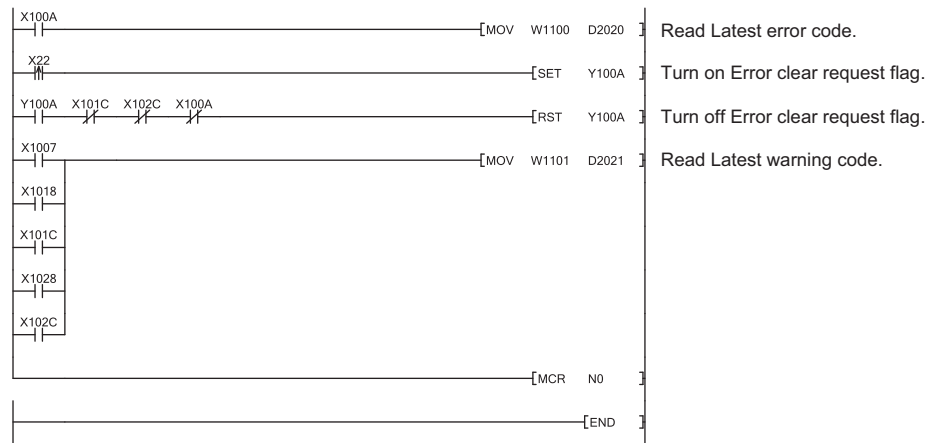

Point!

If the master station does not receive a response for several link scans from the A/D converter module, it is recognized as a cyclic transmission faulty station, resulting in the corresponding bit of the data link status of each station (SW00B0 to SW00B7) turning on.

2. Write the programs to the CPU module of the master station, and reset the CPU module, or turn off and on the power supply.

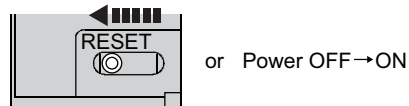

3. Put the CPU module of the master station into RUN.

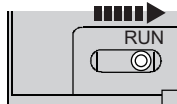

CHAPTER 10 MAINTENANCE AND INSPECTION

There are no special inspection item as an A/D converter module; however, to maintain the best condition of the system, perform the inspection in accordance with the items described in the user's manual for the CPU module used.

Memo

CHAPTER 11 TROUBLESHOOTING

This chapter describes errors that may occur while the A/D converter module is used, and those troubleshooting.

11.1 How to Check Error Codes and Alarm Codes

11

Error codes can be checked by any of the following methods:

- Checking by executing a command of the slave station (☞ Page 169, Section 11.1 (1))
- Checking by Latest error code (RWr0) (☞ Page 172, Section 11.1 (2))
- Checking by Latest warning code (RWr1) (☞ Page 172, Section 11.1 (3))

Alarm codes can be checked by any of the following methods:

- Checking by executing a command of the slave station (☞ Page 169, Section 11.1 (1))
- Checking by Latest warning code (RWr1) (☞ Page 172, Section 11.1 (3))

(1) Checking by executing a command of the slave station

The procedure below shows how to check the errors by executing a command of the slave station.

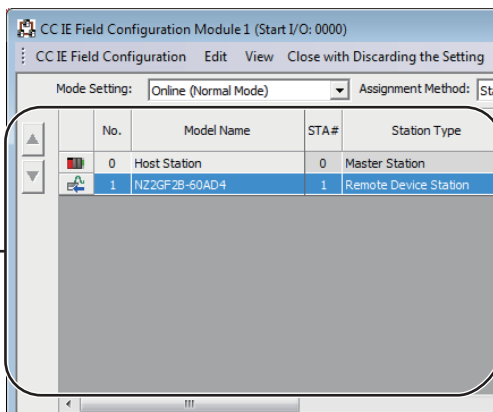

Station list

1. On the "CC IE Field Configuration" window, from "List of stations", select the main A/D converter module.

2. Open the "Command Execution of Slave Station" window.

☞ [CC IE Field Configuration] ⇒ [Online] ⇒ [Command Execution of Slave Station]

3. Set "Method selection" to "Error history read" and click **Execute** button.

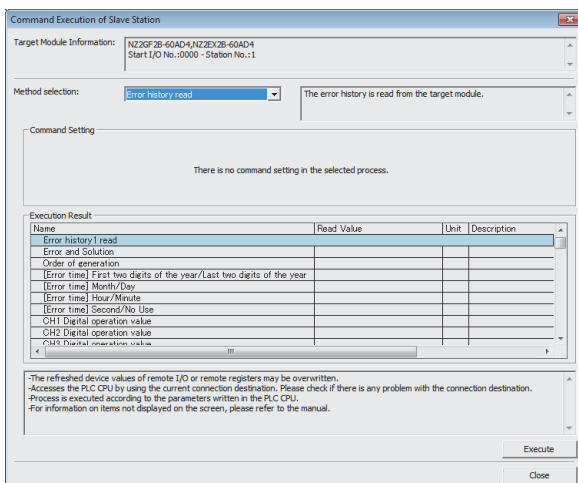

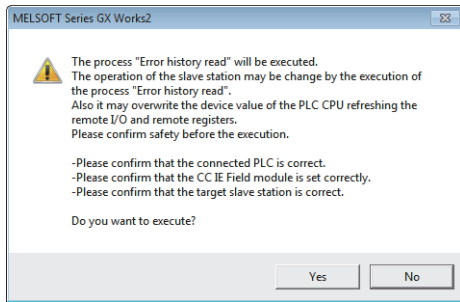

4. In the window that appears (shown left), click **Yes** button.

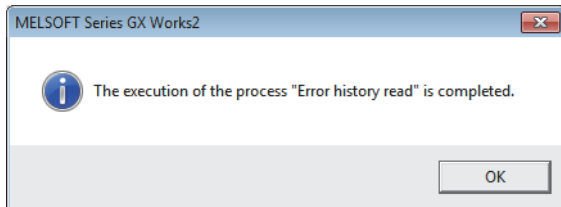

5. In the window that appears (shown left), click **OK** button.

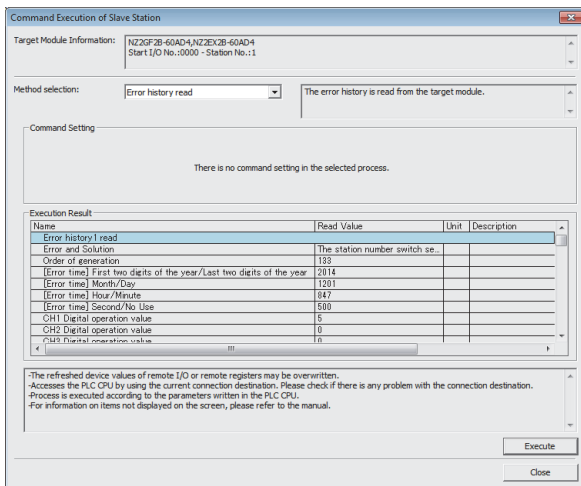

6. The error history of the main A/D converter module and the extension module is displayed in "Execution Result".

Item	Storage contents
Error and Solution	Shows how to take the appropriate action for the error that has occurred.
Order of generation	Shows the order of error occurrence. (A value in the range of 0 to 65535 is stored.)
[Error time] First two digits of the year/Last two digits of the year	Shows the date and time of error occurrence. (When the tens place of Month, Hour and Second is "0", "0" is omitted.)
[Error time] Month/Day	
[Error time] Hour/Minute	
[Error time] Second/No Use	Stores the value in CH□ Digital operation value (RWr2 to RWr5, RWr12 to RWr15) at the time of occurrence of an error.
CH1 Digital operation value	
CH2 Digital operation value	
CH3 Digital operation value	
CH4 Digital operation value	

Point

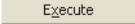
- The error history registers 15 errors at a maximum. If 16 or more errors occur, errors are deleted from the oldest.
- If the same error occurs continuously, only the error that occurred first is stored to the error history.
- Even after the module power supply is turned off and on, the error history remains.
- The clock information of the error that occurred is based on the clock information acquired from the CPU module of the master station. To obtain the accurate data and time of an error, synchronize the clock information of the CPU module to the real time.
- Reading the error history of this module requires the CPU module to be in the STOP status. With the RUN status, the read would fail.
- To initialize the error history, go to the "Command Execution of Slave Station" window to set "Method selection" to "Error history clear request", and then click  button.

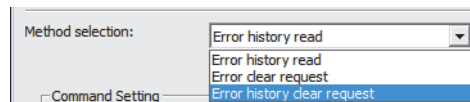

(2) Checking by Latest error code (RWr0)

Carry out a check with the remote register of the master/local module.

 [Online] ⇒ [Monitor] ⇒ [Device/Buffer Memory Batch]

Ex. When the refresh target device for Latest error code (RWr0) is W1100

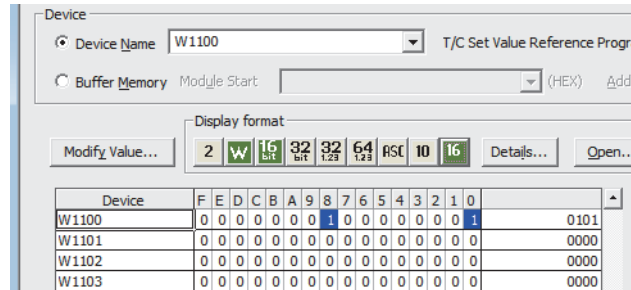

The screenshot shows the 'Device' section of the software interface. The 'Device Name' is set to 'W1100'. The 'Display format' section shows '2 W 16 bit 32 bit 32 bit 64 bit Asc 10 16'. Below this is a table with columns for bits F through 0 and a 'Device' column. The row for 'W1100' shows a '1' in the bit 8 position and a '1' in the bit 0 position, with a hexadecimal value of '0101' in the 'Device' column.

Device	F	E	D	C	B	A	9	8	7	6	5	4	3	2	1	0	
W1100	0	0	0	0	0	0	0	1	0	0	0	0	0	0	0	1	0101
W1101	0	0	0	0	0	0	0	0	0	0	0	0	0	0	0	0	0000
W1102	0	0	0	0	0	0	0	0	0	0	0	0	0	0	0	0	0000
W1103	0	0	0	0	0	0	0	0	0	0	0	0	0	0	0	0	0000

(3) Checking by Latest warning code (RWr1)

Carry out a check with the remote register of the master/local module.

 [Online] ⇒ [Monitor] ⇒ [Device/Buffer Memory Batch]

Ex. When the refresh target device for Latest warning code (RWr1) is W1101

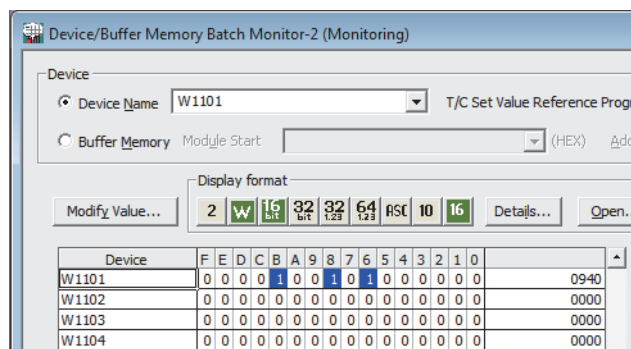

The screenshot shows the 'Device/Buffer Memory Batch Monitor-2 (Monitoring)' window. The 'Device Name' is set to 'W1101'. The 'Display format' section shows '2 W 16 bit 32 bit 32 bit 64 bit Asc 10 16'. Below this is a table with columns for bits F through 0 and a 'Device' column. The row for 'W1101' shows '1's in the bit 9, bit 8, and bit 6 positions, with a hexadecimal value of '0940' in the 'Device' column.

Device	F	E	D	C	B	A	9	8	7	6	5	4	3	2	1	0	
W1101	0	0	0	0	1	0	0	1	0	1	0	0	0	0	0	0	0940
W1102	0	0	0	0	0	0	0	0	0	0	0	0	0	0	0	0	0000
W1103	0	0	0	0	0	0	0	0	0	0	0	0	0	0	0	0	0000
W1104	0	0	0	0	0	0	0	0	0	0	0	0	0	0	0	0	0000

11.2 Error Code List

This section describes error codes.

Error codes are classified by error number as follows.

Error code	Classification	Reference
0000H to 0FFFH, 1F00H to 1F40H, D529H, D52BH	Errors relating to the main A/D converter module	Page 174, Section 11.2.1 (1)
1000H to 1FFFH	Errors relating to the extension A/D converter module	Page 179, Section 11.2.2 (1)
D000H to DFFFH (D529H and D52BH excluded)	Errors relating to the CC-Link IE Field Network (communication error)	Page 178, Section 11.2.1 (2)

11.2.1 Main A/D converter module

(1) Error code list (0000H to 0FFFH, 1F00H to 1F40H, D529H, D52BH)

The errors are classified into the following three types:

Classification	Description
Major error	This error is a sign that recovery is impossible, with the RUN LED turning off.
Moderate error	This error is a sign that the module cannot continue to operate, with the ERR. LED turning on.
Minor error	This error is a sign that the module can continue to operate, with the ERR. LED flashing.

If any of these errors occur, check that the D LINK LED lights up, and take the corrective actions corresponding to the error code with the list below.

Error code (hexadecimal)	Classification	Error name	Description and cause	Action
0010H	Major error	Hardware failure	Module hardware error	Turn off and on the module power supply. If this error persists, the failure of the module is a possible cause. Please consult your local Mitsubishi representative.
010□H	Moderate error	Range setting out-of-range	The value set in Range setting (address: 0103H) is out of the range. □ indicates the number of the channel that has been incorrectly set.	Set the value of Range setting (address: 0103H) within the allowable range.
0110H ^{*1}	Moderate error	Non-volatile memory data error (module working information)	The non-volatile memory data are abnormal.	<ul style="list-style-type: none"> Change Module operation information initialization command (address: 1004H) as follows: Not commanded (0) → Commanded (1) → Not commanded (0). Then, adjust the module operation information of the non-volatile memory to the default value. Take anti-noise measures including the use of shielded cables for connection. If this error persists, the failure of the module is a possible cause. Please consult your local Mitsubishi representative.
0120H ^{*1}	Moderate error	User range data damaged (The channel cannot be identified.)	The value set in the offset/gain setting is invalid. The channel where the error has occurred cannot be identified.	Start over the offset/gain setting of all channels where the user range setting is used. If an error occurs, please consult your local Mitsubishi representative.
0130H	Moderate error	Non-volatile memory data error (parameter)	The parameter data stored in the non-volatile memory are abnormal.	<ul style="list-style-type: none"> Set no request (0), request (1), and no request (0) in Parameter information clear request (address: 1002H) and set the parameters of the non-volatile memory to default. Set the parameters again. Take measures against noise with a shielded cable for connection. If this error persists, the failure of the module is a possible cause. Please consult your local Mitsubishi representative.
0140H	Minor error	Non-volatile memory data error (error history)	The error history data stored in the non-volatile memory are abnormal.	<ul style="list-style-type: none"> The module will be automatically recovered immediately after the error occurs. Note that the error history of the errors that have occurred will be lost. Take measures against noise with a shielded cable for connection. If this error persists, the failure of the module is a possible cause. Please consult your local Mitsubishi representative.
0150H	Minor error	Incorrect network parameter access error	Access to A/D converter module when network parameter was in the incorrect status.	Reset network parameter correctly.
0160H	Minor error	Remote buffer memory access error	A buffer memory area other than the remote buffer memory areas has been accessed using the REMFR/REMTO instruction.	Correct the setting data of the REMFR/REMTO instruction to access the remote buffer memory.

Error code (hexadecimal)	Classification	Error name	Description and cause	Action
017△H	Moderate error	External signal assignment setting error	The addresses set in the external signal assignment function are different from those assigned to the extension I/O module. △ indicates a type of the following errors: 0: Trigger conversion function 1: Input signal error detection function 2: Alert output function 3: Error output 4: Warning output	Adjust the external signal assignment function to fall within the addresses assigned to the extension I/O module.
0180H	Moderate error	Same address for the external signal assignment function	The same address has been set in multiple extension output modules for the external signal assignment function.	Set a unique address.
020□H ^{*1}	Moderate error	Averaging time setting out-of-range	The averaging time value set in CH□ Time average/Count average/Moving average (address: 0105H to 0108H) is outside the range of 2 to 5000ms. □ indicates the number of the channel where an error has occurred.	Set the averaging time to a value in the range of 2 to 5000ms.
			The time average value set in CH□ Time average/Count average/Moving average (address: 0105H to 0108H) is less than "4 × Sampling period" (ms). □ indicates the number of the channel where an error has occurred.	Adjust the time average value to be equal to or greater than "4 × Sampling period" (ms).
030□H ^{*1}	Moderate error	Count average setting out-of-range	The averaging count value set in CH□ Time average/Count average/Moving average (address: 0105H to 0108H) is outside the range of 4 to 65000. □ indicates the number of the channel where an error has occurred.	Set the averaging count to a value in the range of 4 to 65000.
031□H ^{*1}	Moderate error	Moving average setting out-of-range	The moving average count value set in CH□ Time average/Count average/Moving average (address: 0105H to 0108H) is outside the range of 2 to 128. □ indicates the number of the channel where an error has occurred.	Set the moving average count to a value in the range of 2 to 128.
0360H ^{*1}	Moderate error	Conversion speed setting out-of-range	The value set in Conversion speed setting (address: 0001H) is other than 0 and 2.	Set one of the following values in Conversion speed setting (address: 0001H). • 400μs/channel (0H) • 1ms/channel (1H) • 100μs/channel (2H)
040□H ^{*1}	Moderate error	Offset/gain setting value inverted	The user range setting value has been set to a value where the offset value is equal to or greater than the gain value. □ indicates the number of the channel where an error has occurred.	Correct the setting so that the offset value is smaller than the gain value.
06△□H ^{*1}	Moderate error	Process alarm setting error	The settings in CH1 Process alarm lower lower limit value (address: 010FH) to CH4 Process alarm upper upper limit value (address: 011EH) are invalid. □ indicates the number of the channel that has been incorrectly set. △ indicates that the set values are in one of the following conditions: 2: Process alarm lower lower limit value > Process alarm lower upper limit value 3: Process alarm lower upper limit value > Process alarm upper lower limit value 4: Process alarm upper lower limit value > Process alarm upper upper limit value	Correct the settings in CH1 Process alarm lower lower limit value (address: 010FH) to CH4 Process alarm upper upper limit value (address: 011EH).
0730H	Moderate error	Mode switch setting error	A value out of the range is set in mode switch (address: 0000H).	Reset the mode switch (address: 0000H) to either of the followings. • Normal Mode (0H) • Trigger conversion mode (1H) • Automatic judgment mode (9H)

Error code (hexadecimal)	Classification	Error name	Description and cause	Action
081□H ^{*1}	Moderate error	Input signal error detection setting out-of-range	A value out of the range is set for a bit corresponding to any channel of Input signal error detection setting (address: 0109H). □ indicates the number of the channel where an error has occurred.	Set the value in the channel, where an error has occurred in Input signal error detection setting (address: 0109H), to either of the following: <ul style="list-style-type: none"> • Disable (0H) • Disconnection detection (4H)
082□H	Moderate error	Disconnection detection setting error	Disconnection detection (4H) has been set in Input signal error detection setting (address: 0109H), and the input range has been set to a value other than the following values. <ul style="list-style-type: none"> • 4 to 20mA • 1 to 5V □ indicates the number of the channel where an error has occurred.	<ul style="list-style-type: none"> • Set the input range of the channel that detects disconnection within the range of 4 to 20mA or 1 to 5V. • Set Input signal error detection setting (address: 0109H) of the corresponding channel to a value other than Disconnection detection (4H).
090□H ^{*1}	Moderate error	Scaling setting out-of-range	The values set in CH1 Scaling lower limit value (address: 0121H) to CH4 Scaling upper limit value (address: 0128H) are outside the range of -32000 to 32000. □ indicates the number of the channel where an error has occurred.	Set a value within the range of -32000 to 32000 in CH1 Scaling lower limit value (address: 0121H) to CH4 Scaling upper limit value (address: 0128H).
091□H ^{*1}	Moderate error	Scaling upper/lower limit value inverted	The scaling lower limit value has been set equal to or greater than the scaling upper limit value in CH1 Scaling lower limit value (address: 0121H) to CH4 Scaling upper limit value (address: 0128H). □ indicates the number of the channel where an error has occurred.	Correct the settings of CH1 Scaling lower limit value (address: 0121H) to CH4 Scaling upper limit value (address: 0128H) so that the scaling lower limit value is smaller than the scaling upper limit value.
0920H ^{*2}	Minor error	Mode switch setting change	The value set in Mode switch (address: 0000H) has been changed.	Turn off and on the module power supply to operate the module as specified in Mode switch (address: 0000H).
0930H	Moderate error	Cyclic data update watch time setting out-of-range	The value set in Cyclic data update watch time (address: 0007H) is outside the range of 0 to 20.	Set a value within the range of 0 to 20 in Cyclic data update watch time (address: 0007H).
0940H	Minor error	Station number switch changed error	The setting of the station number switch has been changed while the module power is on.	While the module power is on, set the switch again to the station number that has been set before.
0950H	Moderate error	Clock data out-of-range	The clock data acquired from the CPU module is invalid.	The influence of noise or the hardware failure is a possible cause. If the same error occurs again even after measures have been taken against noise, please consult your local Mitsubishi representative.
0960H	Major error	Communication error 3	An invalid data that implies an altered setting of the communication LSI has been received.	Take measures against noise and reset the module. If the same error occurs again, the hardware failure of the module is a possible cause. Please consult your local Mitsubishi representative.
0970H	Major error	Communication error 4	An invalid data that implies an altered setting of the communication LSI has been received.	Take measures against noise and reset the module. If the same error occurs again, the hardware failure of the module is a possible cause. Please consult your local Mitsubishi representative.
0E00H ^{*3}	Moderate error	RWw/RWr setting error	In synchronous communication mode, RWwF/RWrF has not been set in the RWw/RWr setting.	Set RWwF/RWrF to be assigned with the RWw/RWr setting and then turn off and on the power supply, or perform remote reset.
0E10H ^{*3}	Moderate error	Synchronous communication error 1	Synchronous communication with the master station has failed for a certain period of time.	Take the following actions and then turn off and on the power supply, or perform remote reset: <ul style="list-style-type: none"> • Change the synchronization period of the master station to a longer period. Alternatively, reduce the number of slave stations being active in synchronous communication mode. • Taking measures against noise on the transmission path

Error code (hexadecimal)	Classification	Error name	Description and cause	Action
0E20H ^{*3}	Moderate error	Synchronization period setting error	The synchronization period set in the master station is not supported by the A/D converter module.	Adjust the synchronization period of the master station and then turn off and on the power supply of the A/D converter module, or perform remote reset.
0E30H ^{*3}	Moderate error	Synchronous communication error 2	Synchronous communication with the master station has failed for a certain period of time.	Take measures against noise on the transmission path and then turn off and on the module power supply, or perform remote reset.
0E40H ^{*3}	Moderate error	Excessive number of conversion enabled channels	The number of A/D conversion enabled channels is too large to accommodate all the channels in the synchronization period set in the master station.	Take the following actions and then turn off and on the power supply, or perform remote reset: <ul style="list-style-type: none"> • Reduce the number of conversion enabled channels. • Change the synchronization period of the master station to a longer period.
1F00H	Major error	Extension module connection error	The extension module is not connected properly or the connected extension module itself is not supported.	Check whether the extension modules are in contact with each other and whether the extension module is a connectable module. If the same error occurs again, the failure of the module is a possible cause. Please consult your local Mitsubishi representative.
1F20H	Moderate error	External power supply OFF error	The external power supply monitoring function is enabled; however, the external power supply of the extension output module is in an off state.	<ul style="list-style-type: none"> • Check the state of the external power supply of the extension output module. • If an error occurs at the system startup or the system stop, correct the timing to enable the external power supply monitoring function.
1F30H	Moderate error	Extension module parameter error	The mode name reflecting the parameter is different from that of the connected extension module.	Adjust Extension module identification code (address: 0200H) to match the type and the number of points with the connected extension module.
1F40H	Moderate error	Input response time setting error	In the low 3 bits of Input response setting (address: 0010H), 000b or 001b has been set.	Set a value other than 000b and 001b to the low 3 bits of Input response setting (address: 0010H).
D529H	Major error	Communication error 1	An error has occurred in the communication.	<ul style="list-style-type: none"> • The malfunction due to noise or other factors is a possible cause. Check the distance of the wire and cables and the grounding condition of the individual devices. and then take measures against noise. • Execute a unit test for the module. If the same error occurs again, the hardware failure of the module is a possible cause. Please consult your local Mitsubishi representative.
D52BH	Major error	Communication error 2		

*1 To clear the error, modify the set value within the range and perform one of the following two operations:

- Turning on and off Error clear request flag (RYA)
- Turning on and off Initial data setting request flag (RY9)

*2 Mode switch setting change (error code: 0920H) is not cleared even if five seconds has passed since the error occurred. During the error, the operation continues in the mode previous to the change of Mode switch (address: 0000H).

To clear the error staying in the previous mode, set Mode switch (address: 0000H) back to the original value and then turn on and off Initial data setting request flag (RY9).

*3 Turning on and off Error clear request flag (RYA) or Initial data setting request flag (RY9) does not clear this error. The error is cleared only by the method described in the action column.

Point

For two or more errors, only the latest error code is stored in Latest error code (RWr0) or Latest warning code (RWr1). The errors that have occurred in the past can be checked in the error history of the engineering tool.

For the error history, refer to the following:

- Checking by executing a command of the slave station (Page 169, Section 11.1 (1))
- Error history data (Page 223, Appendix 3 (23))

(2) Error code list (D000H to DFFFH (D529H and D52BH excluded))

While any of these errors occurs, the ERR. LED does not turn on. Based on the behavior of the D LINK LED at the occurrence of an error, the errors are classified into two types, each of which requires different troubleshooting.

(a) Communication errors where the D LINK LED flashes or turns off

This type of communication error results in the D LINK LED flashing or being turned off. Troubleshoot the problem with the CC-Link IE Field Network diagnostics. ( Page 153, Section 8.19)

Error code (hexadecimal)	Error name	Description and cause	Action
D0E0H	Station type mismatch	The network parameters are incorrect or out of the range.	In the network configuration settings of the master station, change the station type of the module to the remote device station.
D0E1H	Own station set to reserved station	The network parameters are incorrect or out of the range.	<ul style="list-style-type: none"> In the network configuration settings of the master station, cancel the reserved station specification. Change the station number of the module to a station number that is not specified as a reserved station.
D0E2H	Own station's station number duplication error	The settings of the station number switch are invalid or out of the range.	<ul style="list-style-type: none"> Change the station number avoiding duplication of the station number with other stations. After taking the above action, power off and on or reset all the stations where a own station's station number error has been detected.
D0E3H	Own station's station number out-of-range	The network parameters are incorrect or out of the range.	Add the station information of the module to the network configuration settings of the master station.
D72AH	Station number switch out-of-range (a value other than 1 to 120)	A station number out of the range has been set.	Set the station number within the allowable range.

(b) Communication errors where the D LINK LED does not change

This type of communication error results in no change of the D LINK LED. These errors are not shown in CC-Link IE Field Network diagnostics because they are automatically recovered after the occurrence.



Troubleshooting them requires the error history to be read out. ( Page 169, Section 11.1 (1))

Error code (hexadecimal)	Error name	Description and cause	Action
D217H	Transient data request command error	The transient data request command is incorrect.	Correct the request command at the transient request source, and execute the command again.
D2A0H	Receive buffer full error	There is an overload of the received transient data.	<ul style="list-style-type: none"> Check the network status using CC-Link IE Field Network diagnostics of the engineering tool to take the appropriate action. If the received transient data of the target station is overloaded, leave the send source for a certain time and try to send the data.
D2A3H	Transient data length error	The received transient data is incorrect.	Correct the number of data (frame length) at the request source, and retry the execution.
DF01H	Received transient split error	The received transient data is split.	Set the transient data size that the module can accommodate, and modify the transient data to the one that is not split. Then send it again.

Point

For two or more errors, only the latest error code is stored in Latest error code (RWr0) or Latest warning code (RWr1). The errors that have occurred in the past can be checked in the error history of the engineering tool.

For the error history, refer to the following:

- Checking by executing a command of the slave station ( Page 169, Section 11.1 (1))
- Error history data  ( Page 223, Appendix 3 (23))

11.2.2 Extension A/D converter module

(1) Error code list (1000H to 1FFFH)

The errors are classified into the following two types:

Classification	Description
Major error	This error is a sign that recovery is impossible, with the RUN LED turning off.
Moderate error	This error is a sign that the module cannot continue to operate, with the ERR. LED of the main analog module turning on.

If any of these errors occurs, check that the D LINK LED lights up, and take the corrective actions corresponding to the error code with the list below.

Error code (hexadecimal)	Classification	Error name	Description and cause	Action
1010H	Major error	Hardware failure	Module hardware error	Turn off and on the module power supply. If this error persists, the failure of the module is a possible cause. Please consult your local Mitsubishi representative.
110□H	Moderate error	Range setting out-of-range	The value set in Range setting (address: 0203H) is out of the range. □ indicates the number of the channel that has been incorrectly set.	Adjust the value of Range setting (address: 0203H) to fall within the range.
120□H ^{*1}	Moderate error	Averaging time setting out-of-range	The time average value set in CH□ Time average/Count average/Moving average (address: 0205H to 0208H) is out of the range of 2 to 5000ms. □ indicates the number of the channel where an error has occurred.	Set the averaging time to a value in the range of 2 to 5000ms.
			The time average value set in CH□ Time average/Count average/Moving average (address: 0205H to 0208H) is less than "4 × Sampling period" (ms). □ indicates the number of the channel where an error has occurred.	Adjust the time average value to be equal to or greater than "4 × Sampling period" (ms).
130□H ^{*1}	Moderate error	Count average setting out-of-range	The count average value set in CH□ Time average/Count average/Moving average (address: 0205H to 0208H) is out of the range of 4 to 65000 times. □ indicates the number of the channel where an error has occurred.	Adjust the count average value to fall within the range of 4 to 65000 times.
131□H ^{*1}	Moderate error	Moving average setting out-of-range	The moving average count value set in CH□ Time average/Count average/Moving average (address: 0205H to 0208H) is out of the range of 2 to 128 times. □ indicates the number of the channel where an error has occurred.	Set the moving average count to a value in the range of 2 to 128.
16△□H ^{*1}	Moderate error	Process alarm setting error	The settings in CH1 Process alarm lower limit value (address: 020FH) to CH4 Process alarm upper upper limit value (address: 021EH) have an inconsistency in magnitude relation. □ indicates the number of the channel that has been incorrectly set. △ indicates that the set values are in one of the following conditions: 2: Process alarm lower limit value > Process alarm lower upper limit value 3: Process alarm lower upper limit value > Process alarm upper lower limit value 4: Process alarm upper lower limit value > Process alarm upper upper limit value	Adjust the settings in CH1 Process alarm lower limit value (address: 020FH) to CH4 Process alarm upper upper limit value (address: 021EH).

Error code (hexadecimal)	Classification	Error name	Description and cause	Action
181□H ^{*1}	Moderate error	Input signal error detection setting out-of-range	A bit corresponding to any channel of Input signal error detection setting (address: 0209H) has been set to a value other than the setting range. □ indicates the number of the channel where an error has occurred.	Set one of the following values in the channel, where an error has occurred, of Input signal error detection setting (address: 0209H). • Disable (0H) • Disconnection detection (4H)
182□H	Moderate error	Disconnection detection setting error	A channel where the input range is other than the following is set to Disconnection detection (4H) in Input signal error detection setting (address: 0209H). • 4 to 20mA • 1 to 5V □ indicates the number of the channel where an error has occurred.	• Set the input range of the channel that detects disconnection within the range of 4 to 20mA or 1 to 5V. • Set Input signal error detection setting (address: 0209H) of the corresponding channel to a value other than Disconnection detection (4H).
190□H ^{*1}	Moderate error	Scaling setting out-of-range	The values set in CH1 Scaling lower limit value (address: 0221H) to CH4 Scaling upper limit value (address: 0228H) are out of the range of -32000 to 32000. □ indicates the number of the channel where an error has occurred.	Adjust the value to fall within the range of -32000 to 32000 in CH1 Scaling lower limit value (address: 0221H) to CH4 Scaling upper limit value (address: 0228H).
191□H ^{*1}	Moderate error	Scaling setting upper/lower limit inversion	CH1 Scaling lower limit value (address: 0221H) to CH4 Scaling upper limit value (address: 0228H) have been set as follows: Scaling lower limit value ≥ Scaling upper limit value. □ indicates the number of the channel where an error has occurred.	Adjust the settings of CH1 Scaling lower limit value (address: 0221H) to CH4 Scaling upper limit value (address: 0228H) as follows: Scaling lower limit value < Scaling upper limit value.
1E40H ^{*2}	Moderate error	Excessive number of conversion enabled channels	The number of A/D conversion enabled channels is too large to accommodate all the channels in the synchronization period set in the master station.	Take the following actions and then turn off and on the module power supply, or perform remote reset: • Reduce the number of conversion enabled channels. • Change the synchronization period of the master station to a longer period.
1F00H	Major error	Extension module connection error	The extension module is not connected properly or the connected extension module itself is not supported.	Check the contact state of the extension module and whether the extension module is a connectable module. If the same error occurs again, the failure of the module is a possible cause. Please consult your local Mitsubishi representative.
1F30H	Moderate error	Extension module parameter error	The model name reflecting the parameter is different from that of the connected extension module.	Adjust Extension module identification code (address: 0200H) to match the type and the number of points with the connected extension module.
1F50H	Major error	Extension analog module receive data error	The data received from the extension analog module is abnormal.	• Poor contact of the extension analog module or the influence of noise is a possible cause. • If the error persists even after contact check and anti-noise action, the failure of the module is a possible cause. Please consult your local Mitsubishi representative.
1F60H	Major error	Extension analog module send data error	The data sent to the extension analog module is abnormal.	• Poor contact of the extension analog module or the influence of noise is a possible cause. • If the error persists even after contact check and anti-noise action, the failure of the module is a possible cause. Please consult your local Mitsubishi representative.

*1 To clear the error, modify the set value within the range and perform one of the following two operations:

- Turning on and off Error clear request flag (RYA)
- Turning on and off Initial data setting request flag (RY9)

*2 Turning on and off Error clear request flag (RYA) or Initial data setting request flag (RY9) does not clear this error. The error is cleared only by the method described in the action column.

Point

For two or more errors, only the latest error code is stored in Latest error code (RWr0) or Latest warning code (RWr1). The errors that have occurred in the past can be checked in the error history of the engineering tool.

For the error history, refer to the following:

- Checking by executing a command of the slave station (Page 169, Section 11.1 (1))
- Error history data (Page 223, Appendix 3 (23))

11.3 Alarm Code List

11.3.1 Main A/D converter module

Here is the list of alarm codes:

Alarm code (hexadecimal)	Classification	Alarm name	Description and cause	Action
0A△□H	Minor error	Process alarm occurrence	A process alarm has occurred. □ indicates the number of the channel where a process alarm has occurred. △ indicates the status as follows: 0: Process alarm upper limit 1: Process alarm lower limit	When the digital operation value falls within the setting range, the corresponding bit of Alert output flag (RWrB) and Alert output signal (RX18) turn off automatically and Latest warning code (RWr1) is cleared.
0B△□H	Minor error	Input signal error detection	An input signal error has occurred. □ indicates the number of the channel where an input signal error has occurred. △ indicates the status as follows: 3: Disconnection detection This alarm code is stored when an input signal error is detected according to the setting of the input signal error detection function.	After the analog input value falls within the range, turning on and off Error clear request flag (RYA) results in the corresponding bit of Input signal error detection flag (RWrA) and Input signal error detection signal (RX1C) turning off.

11.3.2 Extension A/D converter module

Here is the list of alarm codes:

Alarm code (hexadecimal)	Classification	Alarm name	Description and cause	Action
1A△□H	Minor error	Process alarm occurrence	A process alarm has occurred. □ indicates the number of the channel where a process alarm has occurred. △ indicates the status as follows: 0: Process alarm upper limit 1: Process alarm lower limit	When the digital operation value falls within the setting range, the corresponding bit of Alert output flag (RWr1B) and Alert output signal (RX28) turn off automatically and Latest warning code (RWr1) is cleared.
1B△□H	Minor error	Input signal error detection	An input signal error has occurred. □ indicates the number of the channel where an input signal error has occurred. △ indicates the status as follows: 3: Disconnection detection This alarm code is stored when an input signal error is detected according to the setting of the input signal error detection function.	After the analog input value falls within the range, turning on and off Error clear request flag (RYA) results in the corresponding bit of Input signal error detection flag (RWr1A) and Input signal error detection signal (RX2C) turning off.

11.4 Checking the LEDs

This section describes how to troubleshoot the system by the LEDs.

Point

For the troubleshooting using the LEDs of the extension I/O module, refer to the following:

☞ CC-Link IE Field Network Remote I/O Module User's Manual

For the troubleshooting using the LEDs of the extension D/A module, refer to the following:

☞ CC-Link IE Field Network Digital-Analog Converter Module User's Manual

11.4.1 Main A/D converter module

(1) When the PW LED does not turn on

Check item	Action
Is any LED other than the PW LED turned on?	If any LED other than the PW LED turns on, the hardware failure is a possible cause. Please consult your local Mitsubishi representative.
Is the module power supply (24VDC) wired?	Wire the module power supply (24VDC).
Is the module power supply (24VDC) supplied?	Supply the module power supply (24VDC).
Does the voltage of the module power supply (24VDC) conform to the specified range?	Adjust the voltage value to conform to the range of performance specifications.

(2) When the RUN LED does not turn on

Check item	Action
Does the voltage of the module power supplied externally reach to the voltage of the performance specifications?	Verify that the voltage of the module power supply lies in the range of performance specifications. (☞ Page 25, Section 3.2)
Does any hardware error occur?	After the check, turn off and on the module power supply. If the RUN LED does not turn on even after the module power supply is turned from off to on, the failure of the module is a possible cause. Please consult your local Mitsubishi representative.

(3) When the MODE LED flashes

Check item	Action
Is the main A/D converter module in the unit test?	If the A/D converter module is in the unit test, the MODE LED turns off after the unit test is completed. Take corrective action according to the result of the unit test. (☞ Page 186, Section 11.5)

(4) When the MODE LED turns off

Check item	Action
Is the main A/D converter module in offset/gain setting mode?	When the A/D converter module is in the offset/gain setting, change the mode to the normal mode after the setting is completed.
Does any hardware error occur?	If the MODE LED does not turn on even after the module power supply is turned from off to on, the hardware failure is a possible cause. Please consult your local Mitsubishi representative.

(5) When the D LINK LED turns off

Check item	Action
Does the own station in network operate normally?	Connect the engineering tool to the master station, and then check if a data link is established in the own station by using CC-Link IE Field Network diagnostics. (📖 User's manual for the master/local module used)
Are 1000BASE-T-compliant Ethernet cables used?	Replace the cable with a 1000BASE-T-compliant Ethernet cable. (📖 User's manual for the master/local module used)
Is the station-to-station distance 100m or less?	Change the station-to-station distance to 100m or less.
Does the cabling condition (bend radius) meet the specifications?	Refer to the manual for the Ethernet cable used, and correct the bend radius.
Is any Ethernet cable disconnected?	Replace the Ethernet cable.
Do other stations connected to the main A/D converter module operate normally?	Check if the power supplies of the other stations are turned on.
Does the switching hub used in the system operate normally?	<ul style="list-style-type: none"> • Check if a 1000BASE-T-compliant switching hub is used. (📖 User's manual for the master/local module used) • Check if the power supply of the switching hub is turned on.
Does the station number of the main A/D converter module overlap with the other stations?	Two or more stations are overlapping. Change the setting so that all the station numbers differ.

(6) When the D LINK LED flashes

Check item	Action
Does the set station number of the main A/D converter module match the station number of the main A/D converter module that is set up in the network configuration settings of the master station or in the CC IE Field configuration?	Match the station number of the main A/D converter module with the station number that is set up in the network configuration settings of the master station or in the CC IE Field configuration.
Is the station type remote device station?	In the network configuration settings of the master station, change the station type to the remote device station.
Is the A/D converter module a reserved station?	Change the setting of reserved/ignored error station to other than the reserved station in the network configuration settings of the master station.
Is stop of the data link checked through CC-Link IE Field Network diagnostics?	Check the link status through CC-Link IE Field Network diagnostics and start the link when the data link is stopped.
Is the station number setting switch set to other than 1 to 120?	The setting range for the station number setting switch is 1 to 120. Set the number between 1 and 120.
Has the connection been changed to the other master station with a different network number?	<ul style="list-style-type: none"> • Correct the connection to the previous master station. • To communicate with the master station with a different network number, power off and on the main A/D converter module.

(7) When the L ER LED turns on

Check item	Action
Are Ethernet cables normal?	<ul style="list-style-type: none"> • Check if 1000BASE-T-compliant Ethernet cables are used. (📖 User's manual for the master/local module used) • Check if the station-to-station distance is 100m or less. • Check if the Ethernet cables are not disconnected.
Does the switching hub in the system normally operate?	<ul style="list-style-type: none"> • Check if a 1000BASE-T-compliant switching hub is used. (📖 User's manual for the master/local module used) • Check if the power supply of the switching hub is turned on.
Do other stations connected to the main A/D converter module operate normally?	Check if the power supplies of the other stations are turned on.
Is the mode of the master station set to other than Online?	Change the mode of the master station to Online.
Is there any noise affecting the system?	Ground the control panel where the A/D converter module is installed.
Is the loopback function enabled for the master station?	When the loopback function is enabled, check if the ring topology is correctly configured for the port where the L ER LED is on. (📖 User's manual for the master/local module used)

(8) When the LINK LED turns off

Check item	Action
Are Ethernet cables normal?	<ul style="list-style-type: none"> • Check if 1000BASE-T-compliant Ethernet cables are used. (📖 User's manual for the master/local module used) • Check if the station-to-station distance is 100m or less. • Check if the Ethernet cables are not disconnected.
Do the switching hub and other stations used in the system operate normally?	Check if the power supplies of the switching hub and other stations are turned on.

Point

If link-up processing is repeated due to a condition of a device on the line, it may take a longer time for the LINK LED to turn on. This phenomenon may be eliminated by changing the module PORT into which the Ethernet cable is connected (example: PORT1 → PORT2). For the wiring of Ethernet cable, refer to the following.

📖 Page 61, Section 6.5

(9) When the ERR. LED turns on

Check item	Action
Does any error occur?	Identify the error factor of the A/D converter module with the engineering tool to take the corrective action. (📖 Page 169, Section 11.1)

(10) When the ALM LED turns on or flashes

(a) When ALM LED turns on

Check item	Action
Has an alert been issued in the main A/D converter module?	Check Alert output flag (RWrB).
Has an alert been issued in the extension A/D converter module?	Check Alert output flag (RWr1B).
Has an alert been issued in the extension D/A converter module?	Check Alert output flag (RWr1A).

(b) When the ALM LED flashes

Check item	Action
Has an input signal error occurred in the main A/D converter module?	Check Input signal error detection flag (RWrA).
Has an input signal error occurred in the extension A/D converter module?	Check Input signal error detection flag (RWr1A).
Has a digital value out-of-range error occurred in the extension D/A converter module?	Check Setting value check code (RWr12 to RWr15) of the corresponding channels.

11.4.2 Extension A/D converter module

(1) When the RUN LED flashes

Check item	Action
Is the external power supply (24VDC) wired?	Carry out the wiring of the external power supply (24VDC).
Is the external power supply (24VDC) supplied?	Supply the external power supply (24VDC).
Does the voltage of the external power supply (24VDC) conform to the specified range?	Adjust the voltage value to conform to the range of performance specifications.

(2) When the RUN LED does not turn on

Check item	Action
Does the main analog module operate in offset/gain setting mode or unit test mode?	If the drive mode of the main analog module is offset/gain setting mode or unit test mode, change the drive mode to another one.
Is the extension A/D converter module properly connected to the main analog module?	<ul style="list-style-type: none"> • If not connected, connect the extension A/D converter module to the main analog module. • If properly connected, refer to the following to verify the connection between the main analog module and the extension A/D converter module: (☞ Page 54, Section 6.3.1) • If the RUN LED does not turn on even after the module power supply is turned from off to on, the hardware failure is a possible cause. Please consult your local Mitsubishi representative.
Has a hardware failure occurred in the main analog module or the extension A/D converter module?	<ul style="list-style-type: none"> • Turn off and on the power supply of the main analog module and the extension A/D converter module. • Replace either of the main analog module and the extension A/D converter module with another module. • If this error persists, the hardware failure is a possible cause. Please consult your local Mitsubishi representative.

11.5 Unit Test

The purpose of a unit test is to check if there is any abnormality in the main A/D converter module.

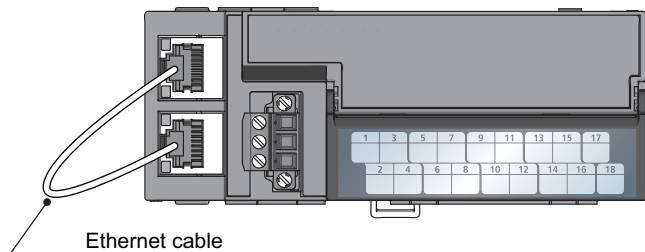

Ethernet cable

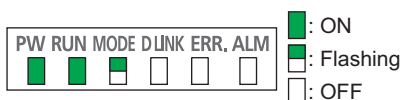
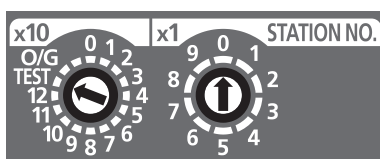

When completed successfully



When completed with an error



1. Turn off the module power supply.
2. Connect the PORT1 and PORT2 connectors of the main A/D converter module with an Ethernet cable.

3. Set up the station number setting switch as follows:

- x10: TEST
- x1: 0

4. Turn on the module power supply.

5. Unit test begins.

The MODE LED flashes during the unit test.

6. Upon the completion of the unit test, the MODE LED turns off.

- When completed normally, the ERR. LED does not turn on, remaining off.
- When completed with an error, the ERR. LED turns on. If the unit test is completed with an error, replace the Ethernet cable and run the test again. If completed with an error again, the hardware failure in the main A/D converter module is a possible cause. Please consult your local Mitsubishi representative.

Remark

When the unit test is completed with an error, the error details can be checked in the error history.

To check the error history, set the station number of the main A/D converter module and connect the module to the master station with an Ethernet cable.

For the error history, refer to the following:

- Checking by executing a command of the slave station (Page 169, Section 11.1 (1))
- Error history data (Page 223, Appendix 3 (23))

11.6 Troubleshooting by Symptom

This section describes troubleshooting problem by problem.

Troubleshooting by symptom is suitable for the case where modules fail to operate normally even though no error has occurred in the A/D converter module. If an error occurs in the A/D converter module, identify the cause of the error using the engineering tool.

11.6.1 Main A/D converter module

(1) When digital operation value cannot be read

Check item	Action
Is there any problem with the wiring, such as looseness or disconnection of analog signal lines?	Identify the faulty area of signal lines by a visual check and a continuity check.
Is the CPU module in the STOP status?	Change the status of the CPU module to RUN.
Is the offset/gain setting correct?	Check if the offset/gain setting is correct. If the user range is used, change the input range to any of the default settings, and then check if the A/D conversion is performed properly. If the A/D conversion is properly executed, configure the offset/gain setting again.
Is the input range setting correct?	Verify Range setting (address: 0103H) by using the engineering tool or the dedicated instruction. If the input range setting is incorrect, set the range again by engineering tool or program.
Is A/D conversion disabled for the channels where the analog value is to be input?	Check A/D conversion enable/disable setting (address: 0102H) by using the engineering tool or the dedicated instruction. Then, set A/D conversion to be enabled by program or engineering tool.
Is Initial data setting request flag (RY9) executed?	Turn on and off Initial data setting request flag (RY9) using the engineering tool to check if the digital operation value is stored in CH□ Digital operation value (RWr2 to RWr5). When the problem has been solved, check the program again.
Are the (V+) and (I+) terminals connected when the current is input?	For the current input, always connect the terminals (V+) and (I+) referring to the following. • Wiring of External Device and Terminal Block (Page 64, Section 6.6)
Are the setting values of the averaging process setting correct?	When the time average processing is selected, set the value to be not less than "Four (times) × Sampling period". If the condition above is not met, 0 is stored into the digital operation value.
Is there any potential difference between the AG terminal and the external device GND?	Connect the AG terminal and the external device GND.
Is the network synchronous communication setting (Synchronous or Asynchronous) changed in the network configuration setting?	If the network synchronous communication setting is changed, turn off and on the power or perform remote reset.
Is an inter-module synchronous interrupt program prepared when the CC-Link IE Field Network synchronous communication function is used together with the inter-module synchronization function on the MELSEC iQ-R series?	For the combined use of the CC-Link IE Field Network synchronous communication function and the inter-module synchronization function on the MELSEC iQ-R series, prepare an inter-module synchronous interrupt program. For the inter-module synchronous interrupt program, refer to the following: MELSEC iQ-R Inter-Module Synchronization Function Reference Manual

Point

If the digital operation value cannot be read even after the above actions are taken, the failure of the main A/D converter module is a possible cause.

Please consult your local Mitsubishi representative.

(2) When an A/D conversion completed flag does not turn on in the normal mode

Check item	Action
Does any input signal error occur?	Check Input signal error detection flag (RWrA).

(3) When the digital operation value is out of the accuracy range

Check item	Action
Is any measure against noise taken?	Take anti-noise measures including the use of shielded cables for connection.

(4) When the output status of the extension output module differs from the link device status of the master station

Check item	Action
Is the setting of the external signal assignment function correct?	<p>Check that the following assignments are not used in the external signal assignment function.</p> <ul style="list-style-type: none"> • Input signal error detection signal assignment (☞ Page 208, Appendix 3 (4)) • Alert output signal assignment (☞ Page 209, Appendix 3 (5)) • Error flag assignment (☞ Page 210, Appendix 3 (6)) • Warning flag assignment (☞ Page 211, Appendix 3 (7))

(5) When parameter read or write, or CC-Link IE Field Network diagnostics fails by engineering tool

Check item	Action
Is the D LINK LED of the main A/D converter module on?	<p>Check the D LINK LED of the main A/D converter module and if it is not on, perform troubleshooting by referring to the following:</p> <ul style="list-style-type: none"> • When the D LINK LED turns off (☞ Page 183, Section 11.4 (5)) • When the D LINK LED flashes (☞ Page 183, Section 11.4 (6)) <p>Check for other LEDs by referring to the following.</p> <ul style="list-style-type: none"> • Checking the LEDs (☞ Page 182, Section 11.4)
Is the version of the module on the master station correct?	<p>Check the serial number (first five digits) of the module on the master station, and if it is prior to the supported versions, replace the module with a module of the supported version. For the supported version, refer to the following:</p> <ul style="list-style-type: none"> • Supported master station (☞ Page 49, Section 5.2 (1))
Is the version of the engineering tool supported?	<p>Check the version of the engineering tool, and if it is prior to the supported versions, update the engineering tool. For the supported version, refer to the following:</p> <ul style="list-style-type: none"> • Supported software package (☞ Page 49, Section 5.2 (4))
Are network parameter settings same as the settings of the CPU module?	<p>Perform "Verify with PLC" and check that network parameter settings match the settings of the CPU module. If they differ, match the settings by performing "Read from PLC" and "Write to PLC", and write the parameters to modules on slave stations.</p>

11.6.2 Extension A/D converter module

(1) When digital operation value cannot be read

Check item	Action
Is there any problem with the wiring, such as looseness or disconnection of analog signal lines?	Check the faulty area by checking signal line visually or conductively.
Is the CPU module in the STOP status?	Change the status of the CPU module to RUN.
Is the input range setting correct?	Verify Range setting (address: 0203H) by using the engineering tool or the dedicated instruction. If the input range setting is incorrect, set the range again by program or engineering tool.
Is A/D conversion disabled for the channels where the analog value is to be input?	Check A/D conversion enable/disable setting (address: 0202H) by using the engineering tool or the dedicated instruction. Then, set A/D conversion to be enabled by program or engineering tool.
Is Initial data setting request flag (RY9) executed?	Turn on and off Initial data setting request flag (RY9) using the engineering tool to check if the digital operation value is stored in CH□ Digital operation value (RWr12 to RWr15). When the problem has been solved, check the program again.
Are the (V+) and (I+) terminals connected when the current is input?	For the current input, always connect the terminals (V+) and (I+) referring to the following. • Wiring of External Device and Terminal Block (☞ Page 64, Section 6.6)
Are the setting values of the averaging process setting correct?	When the time average processing is selected, set the value to be not less than "Four (times) × Sampling period". If the condition above is not met, digital operation values remain 0.
Is there any potential difference between the AG terminal and the external device GND?	Connect the AG terminal and the external device GND.
Is External power supply READY flag (RX2F) on?	If the digital operation value cannot be read out from the extension A/D converter module, check the status of external power supply READY flag (RX2F). If external power supply READY flag (RX2F) is off, adjust external power supply READY flag (RX2F) to turn on with reference to the following: (☞ Page 198, Appendix 1.1 (12))
Does the main analog module operate in offset/gain setting mode or unit test mode?	If the drive mode of the main analog module is offset/gain setting mode or unit test mode, change the drive mode to another one.
Is it impossible to read out an on or off state of the external input normally if the following actions are taken: checking all the items listed above; checking the LEDs of the module; performing CC IE Field diagnostics by engineering tool; and checking the error codes?	Please consult your local Mitsubishi representative.

Point

If the digital operation value cannot be read even after the above actions are taken, the failure of the extension A/D converter module is a possible cause.
Please consult your local Mitsubishi representative.

(2) When an A/D conversion completed flag does not turn on in the normal mode

Check item	Action
Does any input signal error occur?	Check Input signal error detection flag (RWrA).
Is external power supply READY flag (RX2F) on?	If A/D conversion completed flag is not turned on for the extension A/D converter module, check the status of external power supply READY flag (RX2F). If external power supply READY flag (RX2F) is off, adjust external power supply READY flag (RX2F) to turn on with reference to the following: (☞ Page 198, Appendix 1.1 (12))
Does the main analog module operate in offset/gain setting mode or unit test mode?	If the drive mode of the main analog module is offset/gain setting mode or unit test mode, change the drive mode to another one.

(3) When the digital operation value is out of the accuracy range

Check item	Action
Is any measure against noise taken?	Take anti-noise measures including the use of shielded cables for connection.

APPENDICES

Appendix 1 Details of Remote I/O Signals

This section describes the details of remote I/O signals assigned to the master/local module.

The described assignment of device numbers assumes that the remote I/O signals of A/D converter modules are assigned as follows:

Signal name	Main A/D converter module	Extension A/D converter module
Remote input signals	RX0 to RX1F	RX20 to RX2F
Remote output signals	RY0 to RY1F	RY20 to RY2F

Appendix 1.1 Remote input signals

(1) Warning flag

At the occurrence of a minor error, Warning flag (RX7) turns on.

Eliminating the cause of the minor error occurred and waiting for five seconds results in Latest warning code (RWr1) turning to 0000H and Warning flag (RX7) turning off.

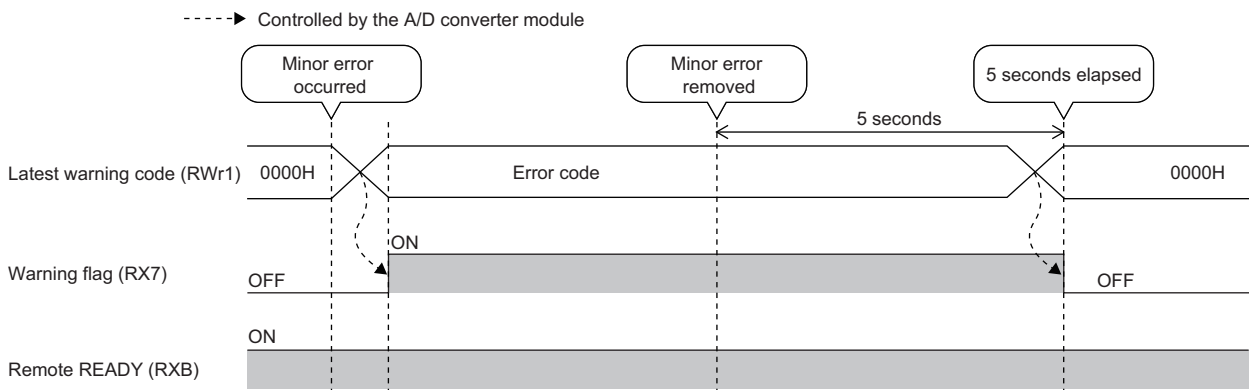

(a) Device number

The device number of this input signal is as follows:

Signal name	Main A/D converter module	Extension A/D converter module
Warning flag	RX7	

(2) Initial data setting completed flag

After writing parameter data to the remote buffer memory using the REMTO instruction, turn on Initial data setting request flag (RY9).

Upon completion of the change of operating conditions, Initial data setting completed flag (RX9) turns on.

For the buffer memory areas that require Initial data setting request flag (RY9) to be turned on and off to enable the written parameter data, refer to the following:

(☞ Page 38, Section 3.7)

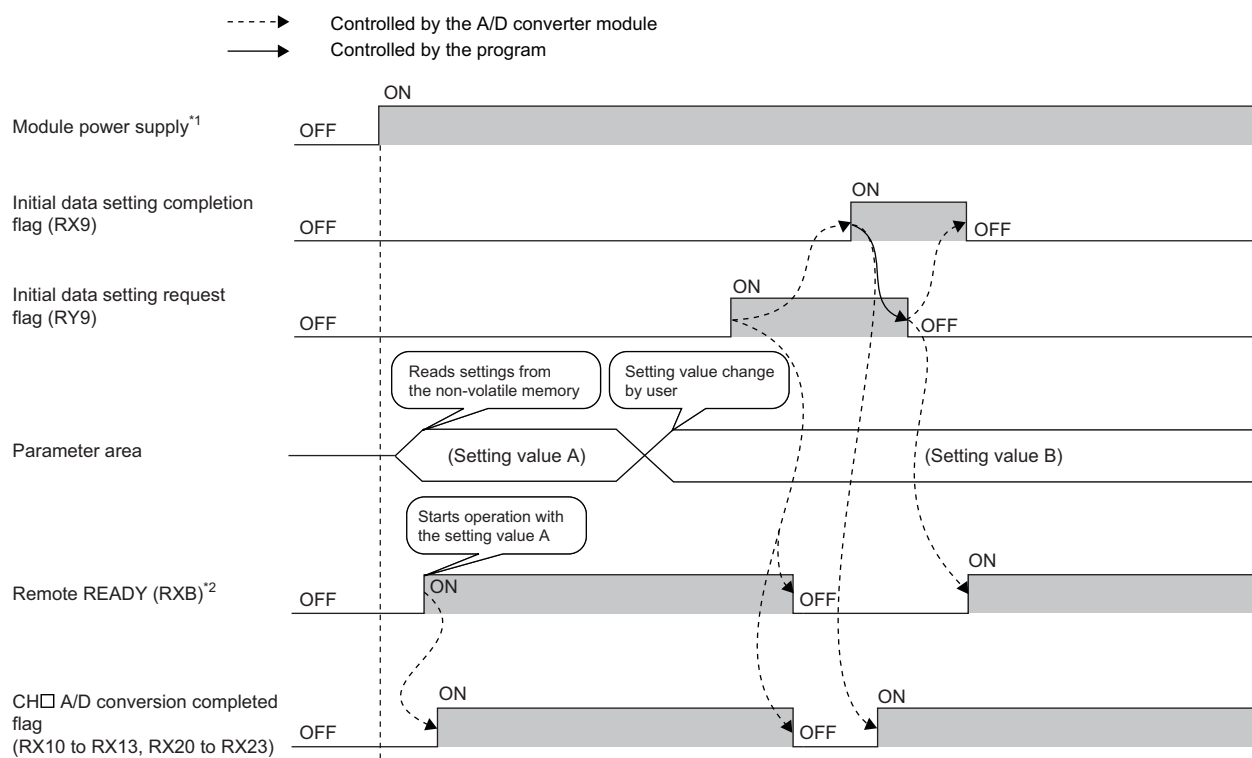

*1 For data link to be made at the power-on of the module power supply

*2 When turning on and off Initial data setting request flag (RY9), check that Remote READY (RXB) turns on before starting the control.

(a) Device number

The device number of this input signal is as follows:

Signal name	Main A/D converter module	Extension A/D converter module
Initial data setting completed flag	RX9	

(3) Error flag

In the event of a moderate error or a major error, Error flag (RXA) turns on.

To clear Latest error code (RWr0), turn on and off Error clear request flag (RYA).

- With a moderate error

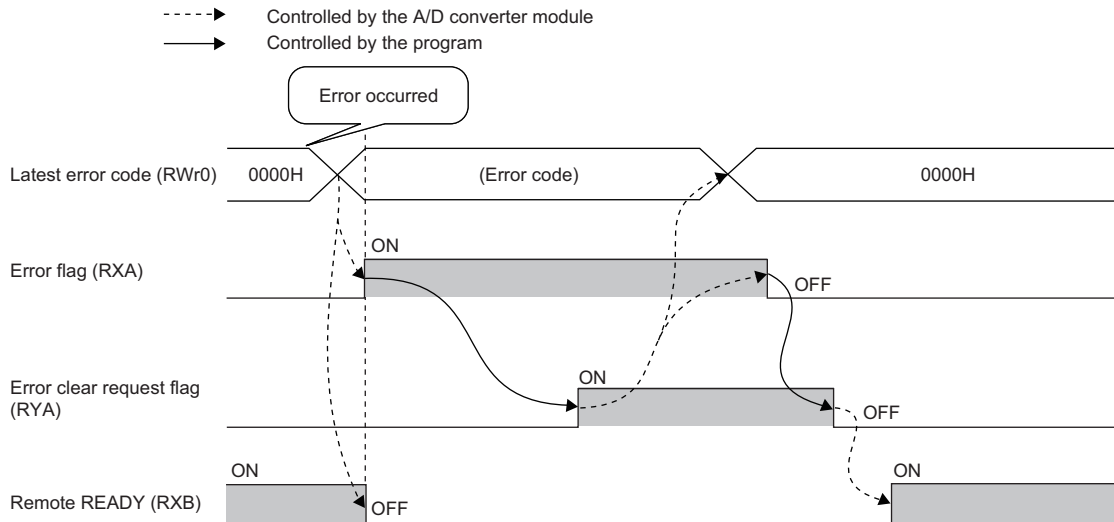

- With a major error

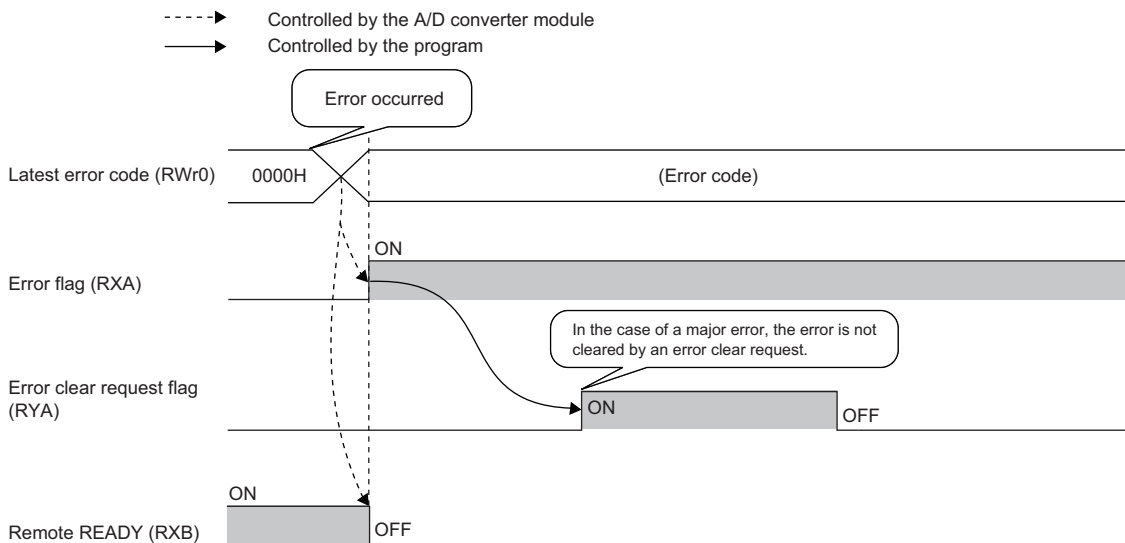

(a) Error history

The error history is not cleared even if Error clear request flag (RYA) is turned on and off. To clear the error history, set "1" in Error history clear command (address: 1000H).

For the error history clear, refer to the following:

- Error history clear command (📄 Page 224, Appendix 3 (24))

(b) Device number

The device number of this input signal is as follows:

Signal name	Main A/D converter module	Extension A/D converter module
Error flag	RXA	

(4) Remote READY

This signal is used as an interlock condition when the master station reads/writes data to/from the remote register or remote buffer memory areas of the A/D converter module.

Upon turning on the module power supply, Remote READY (RXB) turns on.

As Error flag (RXA) turns on, Remote READY (RXB) turns off.

(a) Device number

The device number of this input signal is as follows:

Signal name	Main A/D converter module	Extension A/D converter module
Remote READY	RXB	

(5) CH□ A/D conversion completed flag

CH□ A/D conversion completed flag (RX10 to RX13, RX20 to RX23) turns on as the A/D conversion is completed in the A/D conversion enabled channels.

Turning on and off Initial data setting request flag (RY9) makes the signal return to the default state (off). When A/D conversion is completed, the signal turns on.

(a) Device number

The device numbers of this input signal are as follows:

Signal name	Main A/D converter module				Extension A/D converter module			
	CH1	CH2	CH3	CH4	CH1	CH2	CH3	CH4
CH□ A/D conversion completed flag	RX10	RX11	RX12	RX13	RX20	RX21	RX22	RX23

(6) CH□ Difference conversion state flag

This signal allows the difference conversion status to be checked.

Difference conversion status	CH□ Difference conversion state flag (RX14 to RX17, RX24 to RX27)
Not converted	OFF
Converting difference	ON

- Changing CH□ Difference conversion trigger (RY14 to RY17, RY24 to RY27) from No request (OFF) to Trigger request (ON) results in CH□ Difference conversion state flag (RX14 to RX17, RX24 to RX27) turning to Converting difference (ON).
- Changing CH□ Difference conversion trigger (RY14 to RY17, RY24 to RY27) from Trigger request (ON) to No request (OFF) results in CH□ Difference conversion state flag (RX14 to RX17, RX24 to RX27) turning from Converting difference (ON) to Not converted (OFF).

(a) Device number

The device numbers of this input signal are as follows:

Signal name	Main A/D converter module				Extension A/D converter module			
	CH1	CH2	CH3	CH4	CH1	CH2	CH3	CH4
CH□ Difference conversion state flag	RX14	RX15	RX16	RX17	RX24	RX25	RX26	RX27

(7) Alert output signal

Alert output signal (RX18, RX28) turns on at the detection of a process alarm.

(a) Process alarm

- The signal turns on when the digital operation value, in the channel where the alert output setting (process alarm) is active and A/D conversion is enabled, exceeds the range set in CH1 Process alarm lower limit value (address: 010FH, 020FH) to CH4 Process alarm upper limit value (address: 011EH, 021EH). In addition, the corresponding bit in Alert output flag (RWrB, RWr1B) turns to "1" and the ALM LED of the main A/D converter module turns on.
- When the digital operation values for all the conversion-enabled channels are obtained within the setting range, the corresponding values and status become as follows.

Item	Status
Latest warning code (RWr1)	0000H
Bit position corresponding to the channel relevant to Alert output flag (RWrB, RWr1B)	OFF
Alert output signal (RX18, RX28)	OFF
ALM LED of the main A/D converter module	Lights out

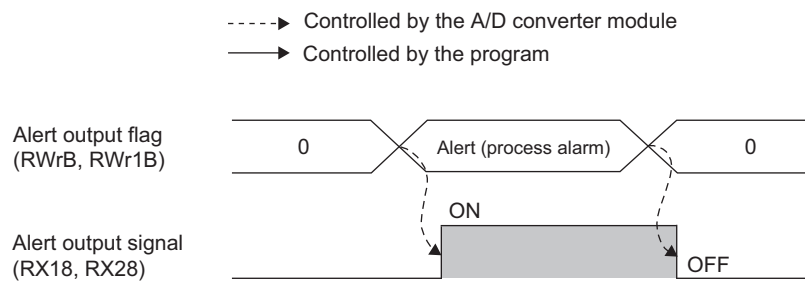

(b) Device number

The device numbers of this input signal are as follows:

Signal name	Main A/D converter module	Extension A/D converter module
Alert output signal	RX18	RX28

(8) Trigger conversion completed flag

- Turning on Trigger conversion request (RY19, RY29) with trigger conversion mode allows A/D conversion in all the channels that enable A/D conversion, resulting in the digital operation values being stored in CH□ Digital operation value (RWr2 to RWr5, RWr12 to RWr15). Once the digital operation values are stored in CH□ Digital operation value (RWr2 to RWr5, RWr12 to RWr15) in all the channels that enable A/D conversion, Trigger conversion completed flag (RX19, RX29) turns from Waiting for conversion (OFF) to Conversion completed (ON).
- Changing Trigger conversion completed clear request (RY1A, RY2A) from No request (OFF) to Clear request (ON) during Conversion completed (ON) of Trigger conversion completed flag (RX19, RX29) results in Trigger conversion completed flag (RX19, RX29) turning from Conversion completed (ON) to Waiting for conversion (OFF). Check that Trigger conversion completed flag (RX19, RX29) turns to Waiting for conversion (OFF), and then turn off Trigger conversion completed clear request (RY1A, RY2A) from on.
- Even if Trigger conversion request (RY19, RY29) is turned on from off during Conversion completed (ON) of Trigger conversion completed flag (RX19, RX29), the A/D conversion is performed and the digital operation value is updated.
- Turning on and off Initial data setting request flag (RY9) results in Trigger conversion completed flag (RX19, RX29) turning off.

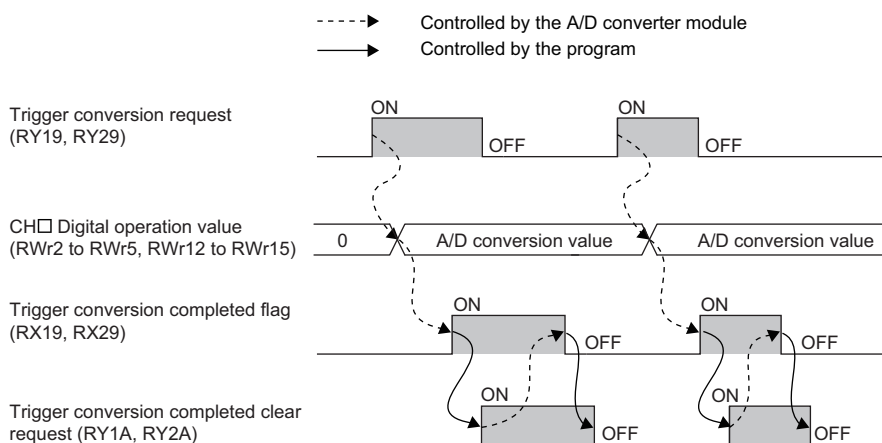

For the trigger conversion function, refer to the following:

- Trigger Conversion Function (👉 Page 128, Section 8.15)

(a) Device number

The device numbers of this input signal are as follows:

Signal name	Main A/D converter module	Extension A/D converter module
Trigger conversion completed flag	RX19	RX29

(9) Input signal error detection signal

(a) ON of Input signal error detection signal

With Input signal error detection setting (address: 0109H, 0209H) set to Disconnection detection (4H), this signal turns on at the detection of a disconnection in any of the A/D conversion enabled channels.

(b) OFF of Input signal error detection signal

After the analog input value returns to a value that is larger than the criteria of disconnection detection (2mA or lower, or 0.5V or lower), turning on and off Error clear request flag (RYA) results in Input signal error detection signal (RX1C, RX2C) turning off.

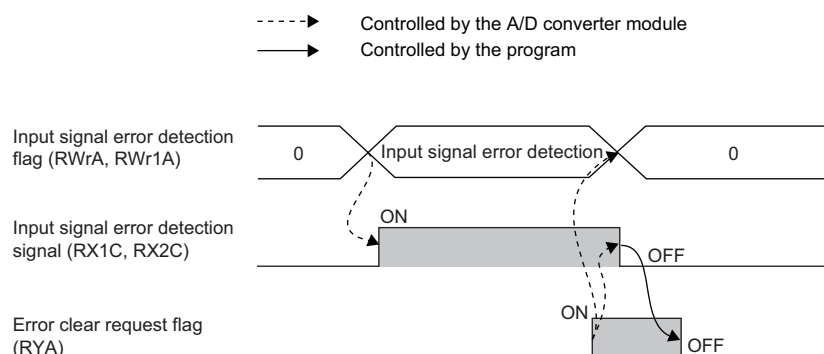

Check that Input signal error detection signal (RX1C, RX2C) is off before turning off Error clear request flag (RYA) from on. Turning on and off Error clear request flag (RYA) before Input signal error detection signal (RX1C, RX2C) turns off does not allow Input signal error detection signal (RX1C, RX2C) to be cleared.

(c) When Input signal error detection signal turns on

- CH□ A/D conversion completed flag (RX10 to RX13, RX20 to RX23) in the corresponding channels turns off.
- For the error-detected channel, the digital operation value immediately before the error detection is held in the buffer memory.
- The ALM LED flashes.

(d) When Input signal error detection signal turns off

- The ALM LED turns off.
- Latest warning code (RW1) is cleared.

Point

Once the analog input value returns to a value enough to pass the disconnection detection criterion (2mA or lower, or 0.5V or lower), A/D conversion resumes whether Input signal error detection signal (RX1C, RX2C) is reset or not. Completion of the first A/D conversion after the restart results in CH□ A/D conversion completed flag (RX10 to RX13, RX20 to RX23) in the corresponding channel turning on again. Averaging processing starts over after the A/D conversion resumed.

(e) Device number

The device numbers of this input signal are as follows:

Signal name	Main A/D converter module	Extension A/D converter module
Input signal error detection signal	RX1C	RX2C

(10) Maximum value/minimum value reset completed flag

This signal turns on when the maximum value stored in CH□ Maximum value (address: 0601H, 0603H, 0605H, 0607H, 0701H, 0703H, 0705H, 0707H) and the minimum value stored in CH□ Minimum value (address: 0602H, 0604H, 0606H, 0608H, 0702H, 0704H, 0706H, 0708H) are reset by turning on and off Maximum value/minimum value reset request (RY1D).

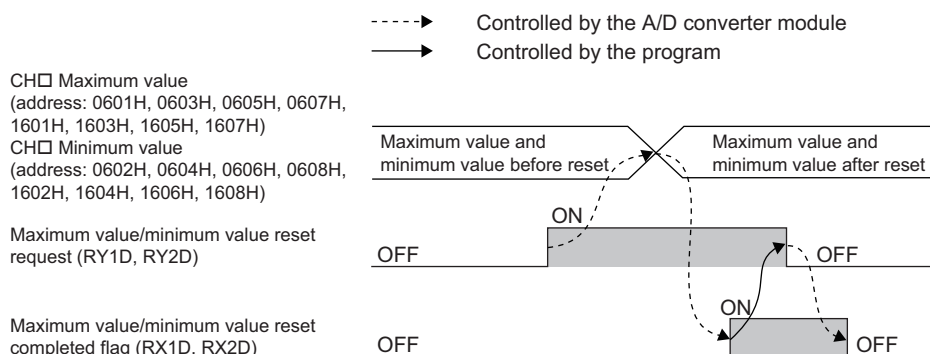

(a) Device number

The device numbers of this input signal are as follows:

Signal name	Main A/D converter module	Extension A/D converter module
Maximum value/minimum value reset completed flag	RX1D	RX2D

(11) External power supply monitor state flag

This signal turns on when the external power supply monitoring function is being activated by External power supply monitor request flag (RY1F).

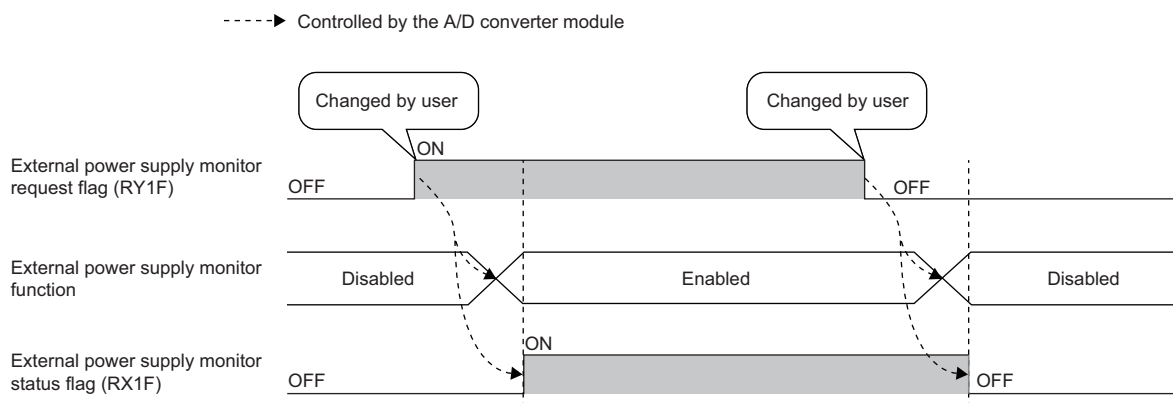

For the external power supply monitoring function, refer to the following:

- External power supply monitoring function (Page 146, Section 8.18.1 (1))

(a) Device number

The device number of this input signal is as follows:

Signal name	Main A/D converter module	Extension A/D converter module
External power supply monitor state flag	RX1F	—

(12) External power supply READY flag

This signal indicates the state of the external power supply of the extension A/D converter module.

(a) Behavior when the external power supply of the extension A/D converter module is in an off state

External power supply READY flag (RX2F) remains off, and the RUN LED of the extension A/D converter module flashes.

A/D conversion processing is not performed on the extension A/D converter module, and A/D conversion completed flag (RX20 to RX23) of the extension A/D converter module remains off.

(b) Behavior when the external power supply of the extension A/D converter module is turned on from off

When the external power supply is turned from off to on, External power supply READY flag (RX2F) turns on, and the RUN LED of the extension A/D converter module lights up. A/D conversion processing starts in the conversion enabled channels of the extension A/D converter module.

(c) Behavior when the external power supply of the extension A/D converter module is turned off from on

When the external power supply is turned from on to off, External power supply READY flag (RX2F) turns off, and the RUN LED of the extension A/D converter module flashes.

A/D conversion processing stops on the extension A/D converter module, and A/D conversion completed flag (RX20 to RX23) of the extension A/D converter module turns off.

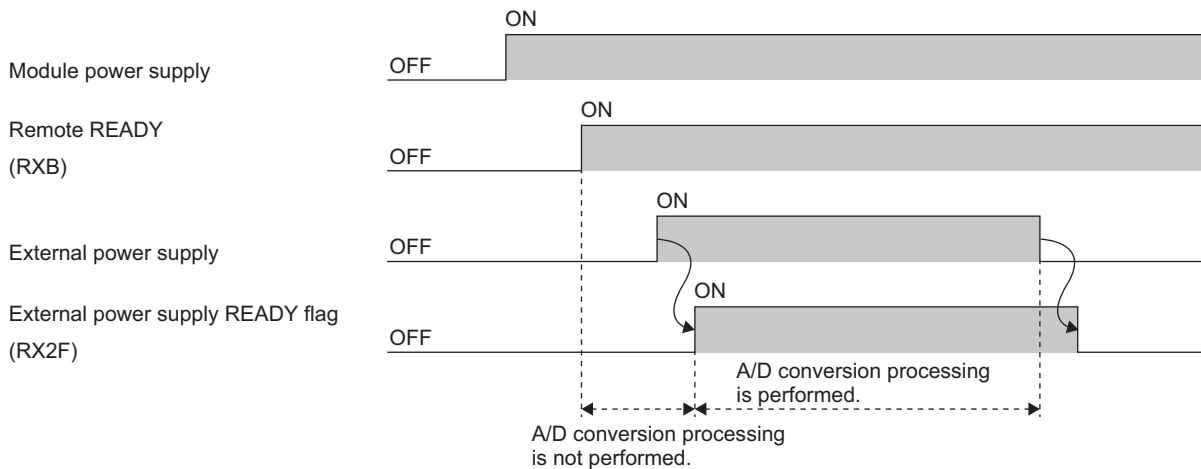

(d) Device number

The device number of this input signal is as follows:

Signal name	Main A/D converter module	Extension A/D converter module
External power supply READY flag	—	RX2F

Point

- A/D conversion processing on the main A/D converter module works regardless of an on or off state of the external power supply of the extension A/D converter module.
- Use an external power supply that meets the specifications described in Performance specifications (Page 27, Section 3.2.2). If it does not meet the specifications, External power supply READY flag (RX2F) remains off.
- When using the extension A/D converter module, use it with an interlock condition.

Appendix 1.2 Remote output signals

(1) Initial data setting request flag

Turn on Initial data setting request flag (RY9) after writing parameter data to the remote buffer memory. Upon completion of the change of operating conditions, Initial data setting completed flag (RX9) turns on.

For the timing "OFF→ON→OFF", refer to the following:

- Initial data setting completed flag (☞ Page 191, Appendix 1.1 (2))

(a) Device number

The device number of this output signal is as follows:

Signal name	Main A/D converter module	Extension A/D converter module
Initial data setting request flag	RY9	

(2) Error clear request flag

This signal is used for clearing Error flag (RXA), Input signal error detection signal (RX1C, RX2C), and Latest error code (RWr0).

(a) When a moderate error or input signal error detection occurs

Eliminating the cause of the error and turning on Error clear request flag (RYA) from off allows the error status to be cleared, resulting in Error flag (RXA) turning off.

Before Error flag (RXA) turns off, turning off Error clear request flag (RYA) from on does not allow Error flag (RXA) to turn off.

For the timing "OFF→ON→OFF", refer to the following:

- Error flag (☞ Page 192, Appendix 1.1 (3))
- Input signal error detection signal (☞ Page 196, Appendix 1.1 (9))

(b) When a major error occurs

Error flag (RXA) does not turn off even by turning on and off Error clear request flag (RYA).

For the timing "OFF→ON→OFF", refer to the following:

- Error flag (☞ Page 192, Appendix 1.1 (3))

(c) Device number

The device number of this output signal is as follows:

Signal name	Main A/D converter module	Extension A/D converter module
Error clear request flag	RYA	

(3) CH□ Difference conversion trigger

This signal is used as a trigger to start and stop the difference conversion.

For details on the difference conversion function, refer to the following:

- Difference Conversion Function (☞ Page 123, Section 8.14)

Difference conversion trigger	Setting value
No request	OFF
Trigger request	ON

(a) Starting/Stopping the difference conversion

- Changing CH□ Difference conversion trigger (RY14 to RY17, RY24 to RY27) from No request (OFF) to Trigger request (ON) initiates difference conversion.
- Changing CH□ Difference conversion trigger (RY14 to RY17, RY24 to RY27) from Trigger request (ON) to No request (OFF) stops the difference conversion.

(b) Device number

The device numbers of this output signal are as follows:

Signal name	Main A/D converter module				Extension A/D converter module			
	CH1	CH2	CH3	CH4	CH1	CH2	CH3	CH4
CH□ Difference conversion trigger	RY14	RY15	RY16	RY17	RY24	RY25	RY26	RY27

(4) Trigger conversion request

In trigger conversion mode, turning on Trigger conversion request (RY19, RY29) from off allows A/D conversion to be performed only once in all the channels that are set to enable A/D conversion using the trigger conversion function.

For the timing "OFF→ON→OFF", refer to the following:

- Trigger conversion completed flag (☞ Page 195, Appendix 1.1 (8))

For the trigger conversion function, refer to the following:

- Trigger Conversion Function (☞ Page 128, Section 8.15)

(a) Device number

The device numbers of this output signal are as follows:

Signal name	Main A/D converter module	Extension A/D converter module
Trigger conversion request	RY19	RY29

(5) Trigger conversion completed clear request

- Changing Trigger conversion completed clear request (RY1A, RY2A) from No request (OFF) to Clear request (ON) during Conversion completed (ON) of Trigger conversion completed flag (RX19, RX29) results in Trigger conversion completed flag (RX19, RX29) turning from Conversion completed (ON) to Waiting for conversion (OFF).
- Changing Trigger conversion completed clear request (RX19, RX29) from No request (OFF) to Clear request (ON) during Waiting for conversion (OFF) of Trigger conversion completed flag (RX19, RX29) does not affect Trigger conversion completed flag (RX19, RX29), which remains Waiting for conversion (OFF).
- Even after Trigger conversion completed flag (RX19, RX29) turns to Conversion completed (ON), Trigger conversion completed flag (RX19, RX29) remains Conversion completed (ON) unless Trigger conversion completed clear request (RY1A, RY2A) is turned from No request (OFF) to Clear request (ON).

For the timing "OFF→ON→OFF", refer to the following:

- Trigger conversion completed flag (☞ Page 195, Appendix 1.1 (8))

For the trigger conversion function, refer to the following:

- Trigger Conversion Function (☞ Page 128, Section 8.15)

(a) Device number

The device numbers of this output signal are as follows:

Signal name	Main A/D converter module	Extension A/D converter module
Trigger conversion completed clear request	RY1A	RY2A

(6) Maximum value/minimum value reset request

Turning on and off Maximum value/minimum value reset request (RY1D, RY2D) allows CH□ Maximum value (address: 0601H, 0603H, 0605H, 0607H, 0701H, 0703H, 0705H, 0707H) and CH□ Minimum value (address: 0602H, 0604H, 0606H, 0608H, 0702H, 0704H, 0706H, 0708H) to be cleared.

For the timing "OFF→ON→OFF", refer to the following:

- Maximum value/minimum value reset completed flag (☞ Page 197, Appendix 1.1 (10))

(a) Device number

The device numbers of this output signal are as follows:

Signal name	Main A/D converter module	Extension A/D converter module
Maximum value/minimum value reset request	RY1D	RY2D

(7) External power supply monitor request flag

Turn on this signal to activate the external power supply monitoring function.

For the timing "OFF→ON→OFF", refer to the following:

External power supply monitor state flag (☞ Page 197, Appendix 1.1 (11))

(a) Device number

The device number of this output signal is as follows:

Signal name	Main A/D converter module	Extension A/D converter module
External power supply monitor request flag	RY1F	—

Appendix 2 Details of Remote Registers

This section describes the details of the remote registers for a master/local module.

The described assignment of device numbers assumes that the remote registers of the main module are assigned to RWr0 to RWrF and RWw0 to RWwF.

(1) Latest error code

An error code is stored when a moderate error or major error occurs.

Turning on Error clear request flag (RYA) after eliminating the cause of the error clears the error code.

Errors that occurred in the past can be checked with Error history □ (address: 0A00H to 0AEFH). For the error history, refer to the following:

- Error history data□ (☞ Page 223, Appendix 3 (23))

(a) Device number

The device number of this remote register is as follows:

Remote register name	Main A/D converter module	Extension A/D converter module
Latest error code	RWr0	

(2) Latest warning code

An error code is stored when a minor error occurs. An alarm code is stored when an alarm occurs.

After a minor error has occurred, eliminating the cause of the error and then waiting for five seconds results in Latest warning code (RWr1) being automatically cleared.

Errors or alarms that occurred in the past can be checked with Error history □ (address: 0A00H to 0AEFH). For error history, refer to the following:

- Error history data□ (☞ Page 223, Appendix 3 (23))

(a) Device number

The device number of this remote register is as follows:

Remote register name	Main A/D converter module	Extension A/D converter module
Latest warning code	RWr1	

(3) CH□ Digital operation value

The digital operation value which is obtained by the digital clipping function, scaling function, shift function, and difference conversion function is stored as signed 16-bit binary.

(a) Device number

The device numbers of this remote register are as follows:

Remote register name	Main A/D converter module				Extension A/D converter module			
	CH1	CH2	CH3	CH4	CH1	CH2	CH3	CH4
CH□ Digital operation value	RWr2	RWr3	RWr4	RWr5	RWr12	RWr13	RWr14	RWr15

(4) CH□ Difference conversion reference value

The digital operation value at the start of the difference conversion is stored as signed 16-bit binary as the difference conversion reference value.

Point

- The difference conversion reference value is updated when CH□ Difference conversion trigger (RY14 to RY17, RY24 to RY27) is turned from No request (OFF) to Trigger request (ON).
- Even if CH□ Difference conversion state flag (RX14 to RX17, RY24 to RY27) is turned from Converting difference (ON) to Not converted (OFF), CH□ Difference conversion reference value (RWr6 to RWr9, RWr16 to RWr19) is not cleared.
 - Difference Conversion Function (Page 123, Section 8.14)

(a) Device number

The device numbers of this remote register are as follows:

Remote register name	Main A/D converter module				Extension A/D converter module			
	CH1	CH2	CH3	CH4	CH1	CH2	CH3	CH4
CH□ Difference conversion reference value	RWr6	RWr7	RWr8	RWr9	RWr16	RWr17	RWr18	RWr19

(5) Input signal error detection flag

Input signal status can be checked with this flag for each channel.

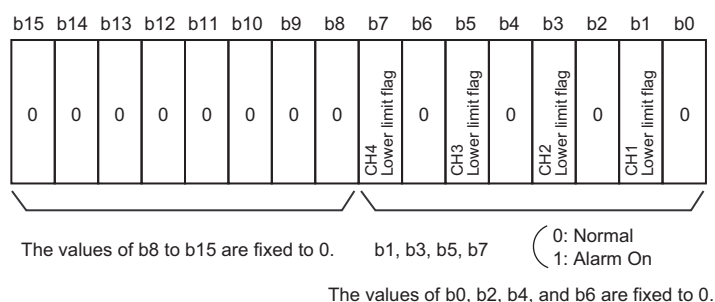

(a) The state of Input signal error detection flag

- When Input signal error detection setting (address: 0109H, 0209H) is set to Disconnection detection (4H), the set channel is monitored to detect a disconnection. When the analog input value satisfies the disconnection detection condition (2mA or 0.5V or less), the bit of the lower limit flag in the corresponding channel turns to Alarm ON (1).
- With the input signal error detection function used, an error detected in any of the channels where A/D conversion is set to be enabled results in Input signal error detection signal (RX1C, RX2C) being turned on.

(b) Clearing Input signal error detection flag

- After the analog input value returns to a value that is larger than the criteria of disconnection detection (2mA or lower or 0.5V or lower), turning on and off Error clear request flag (RYA) results in this flag being cleared.
- Turning on and off Initial data setting request flag (RY9) results in this flag being cleared.

(c) Device number

The device numbers of this remote register are as follows:

Remote register name	Main A/D converter module				Extension A/D converter module			
	CH1	CH2	CH3	CH4	CH1	CH2	CH3	CH4
Input signal error detection flag	RWrA				RWr1A			

(6) Alert output flag

Whether the upper limit value or the lower limit value causes the alert can be checked for each channel.

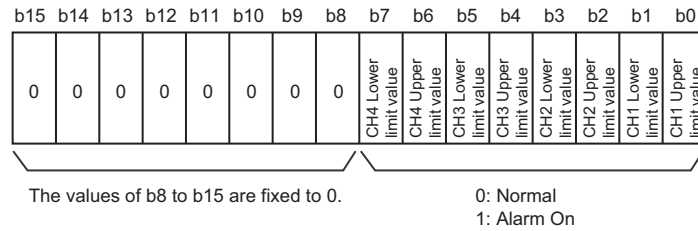

(a) The state of Alert output flag (RWrB)

- If the value is out of the range specified in CH1 Process alarm lower lower limit value (address: 010FH, 020FH) to CH4 Process alarm upper upper limit value (address: 011EH, 021EH), Alert output flag (RWrB, RWr1B) corresponding to each channel turns to Alarm ON (1).
- Of the A/D conversion enabled channels and the alert output enabled channels, an alert detected even in one channel results in Alert output signal (RX18, RX28) being turned on.

(b) Clearing Alert output flag

- When the digital operation value returns within the setting range, Alert output flag (RWrB) is automatically cleared.
- Turning on and off Initial data setting request flag (RY9) results in this flag being cleared.

(c) Device number

The device numbers of this remote register are as follows:

Remote register name	Main A/D converter module				Extension A/D converter module			
	CH1	CH2	CH3	CH4	CH1	CH2	CH3	CH4
Alert output flag	RWrB				RWr1B			

(7) CH□ Conversion value shift amount

Set the shifting amount to conversion value that is to be used for the shift function in signed 16-bit binary. The digital operation values after shift-and-add are stored to CH□ Digital operation value (RWr2 to RWr5, RWr12 to RWr15).

For details on the shift function, refer to the following:

- Shift Function (📖 Page 114, Section 8.12)

(a) Setting range

Setting range is -32768 to 32767.

(b) Enabling the setting

Once a value is set, the conversion value shift amount is valid regardless of turning on and off Initial data setting request flag (RY9).

(c) Device number

The device numbers of this remote register are as follows:

Remote register name	Main A/D converter module				Extension A/D converter module			
	CH1	CH2	CH3	CH4	CH1	CH2	CH3	CH4
CH□ Conversion value shift amount	RWw2	RWw3	RWw4	RWw5	RWw12	RWw13	RWw14	RWw15

Appendix 3 Details of Remote Buffer Memory

This section describes the details of the remote buffer memory.

(1) Mode switch

Set the mode for all channels.

Mode	Setting value
Normal mode	0H
Trigger conversion mode	1H
Automatic judgment mode	9H

Setting a value other than the above results in the error code (0730H) being stored in Latest error code (RWr0), Error flag (RXA) turning on, and the ERR. LED lighting up, with Automatic judgment mode (9H) set up.

(a) Enabling the setting

1. Turn on and off Initial data setting request flag (RY9).
2. Check that "0920H" is stored in Latest warning code (RWr1).
3. Turn off and on the power supply.

(b) Default value

The default value is Automatic judgment mode (9H).

(c) Remote buffer memory address

The remote buffer memory address of this area is as follows:

Remote buffer memory name	Main A/D converter module	Extension A/D converter module
Mode switch	0000H	

(2) Conversion speed switch

Set the conversion speed for all channels.

Conversion speed	Setting value
400 μ s/channel	0H
1ms/channel	1H
100 μ s/channel	2H

In trigger conversion mode or synchronous communication mode, setting the conversion speed to 1ms/channel (1H) results in operation at 400 μ s/channel.

A value out of the range above results in the error code (0360H) being stored in Latest error code (RWr0), Error flag (RXA) turning on, and the ERR. LED lighting up.

(a) Enabling the setting

Turn on and off Initial data setting request flag (RY9) to enable the setting.

(b) Default value

The default value is 400 μ s/channel (0H).

(c) Remote buffer memory address

The remote buffer memory address of this area is as follows:

Remote buffer memory name	Main A/D converter module	Extension A/D converter module
Conversion speed switch	0001H	

(3) Trigger conversion signal assignment

Assign Trigger conversion request (RY19) of the main A/D converter module to Remote input (RX) of the extension input module by using the external signal assignment function. Turning on the assigned Remote input (RX) from off allows A/D conversion to be performed through the trigger conversion function.

(a) Setting range

With the head of Remote input (RX) of the main A/D converter module as a starting point (0000H), set the number, which is counted from the head, of Remote input (RX) of the extension input module.

Ex. When Trigger conversion request (RY19) is assigned to Remote input (RX) numbered 8H as counted from the head (0H) of the extension input module

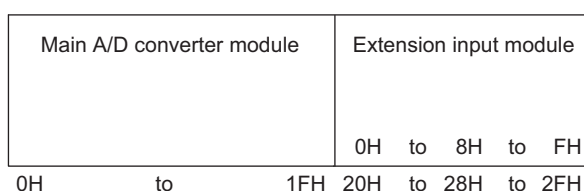

Remote input (RX) numbered 8H as counted from the head of the extension input module corresponds to Remote input (RX) numbered 28H as counted from the head of the main A/D converter module.

Thus, set 28H for Trigger conversion signal assignment (address: 0002H).

(b) Enabling the setting

Turn on and off Initial data setting request flag (RY9) to enable the setting.

(c) Default value

The default value is No assignment (FFFFH).

(d) Remote buffer memory address

The remote buffer memory address of this area is as follows:

Remote buffer memory name	Main A/D converter module	Extension A/D converter module
Trigger conversion signal assignment	0002H	—

Point

- Setting a value out of the range results in the error code (0170H) being stored in Latest error code (RW_r0), Error flag (RXA) turning on, and the ERR. LED lighting up. with the previously set operation.
- With Trigger conversion signal assignment (address: 0002H) set to Remote input (RX) of the extension input module, turning on Trigger conversion request (RY19) of the main A/D converter module from off does not allow A/D conversion. Turn on Remote input (RX), which is set in Trigger conversion signal assignment (address: 0002H), from off.

(4) Input signal error detection signal assignment

Assign Input signal error detection signal (RX1C) of the main A/D converter module to Remote output (RY) of the extension output module by using the external signal assignment function. When an error of an input signal is detected, assigned Remote output (RY) turns on.

(a) Setting range

With the head of Remote output (RY) of the main A/D converter module as a starting point (0000H), set the number, which is counted from the head, of Remote output (RY) of the extension output module.

Ex. When Input signal error detection signal (RX1C) is assigned to the first Remote output (RY) of the extension output module

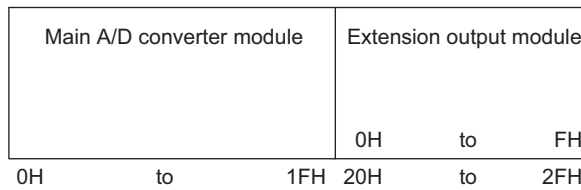

The first Remote output (RY) of the extension output module corresponds to Remote output (RY) numbered 20H as counted from the head of the main A/D converter module.

Thus, set 20H for Input signal error detection signal assignment (address: 0003H).

(b) Enabling the setting

Turn on and off Initial data setting request flag (RY9) to enable the setting.

(c) Default value

The default value is No assignment (FFFFH).

(d) Remote buffer memory address

The remote buffer memory address of this area is as follows:

Remote buffer memory name	Main A/D converter module	Extension A/D converter module
Input signal error detection signal assignment	0003H	—



Setting a value out of the range results in the error code (0171H) being stored in Latest error code (RWr0), Error flag (RXA) turning on, and the ERR. LED lighting up, with the previously set operation.

(5) Alert output signal assignment

Assign Alert output signal (RX18) of the main A/D converter module to Remote output (RY) of the extension output module by using the external signal assignment function. When an alert is issued, assigned Remote output (RY) is turned on.

(a) Setting range

With the head of Remote output (RY) of the main A/D converter module as a starting point (0000H), set the number, which is counted from the head, of Remote output (RY) of the extension output module.

Ex. When Alert output signal (RX18) is assigned to Remote output (RY) numbered 2H as counted from the head (0H) of the extension output module

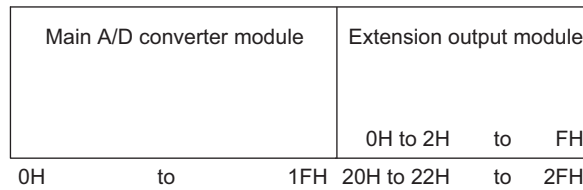

Remote output (RY) numbered 2H as counted from the head of the extension output module corresponds to Remote output (RY) numbered 22H as counted from the head of the main A/D converter module. Thus, set 22H for Alert output signal assignment (address: 0004H).

(b) Enabling the setting

Turn on and off Initial data setting request flag (RY9) to enable the setting.

(c) Default value

The default value is No assignment (FFFFH).

(d) Remote buffer memory address

The remote buffer memory address of this area is as follows:

Remote buffer memory name	Main A/D converter module	Extension A/D converter module
Alert output signal assignment	0004H	—

Point

Setting a value out of the range results in the error code (0172H) being stored in Latest error code (RWr0), Error flag (RXA) turning on, and the ERR. LED lighting up, with the previously set operation.

(6) Error flag assignment

Assign Error flag (RXA) to Remote output (RY) of the extension output module using the external signal assignment function. When a moderate error or major error occurs, assigned Remote output (RY) is turned on.

(a) Setting range

With the head of Remote output (RY) of the main A/D converter module as a starting point (0000H), set the device number for Remote output (RY) of the connected extension output module.

Ex. When Error flag (RXA) is assigned to Remote output (RY) numbered 4H as counted from the head (0H) of the extension output module

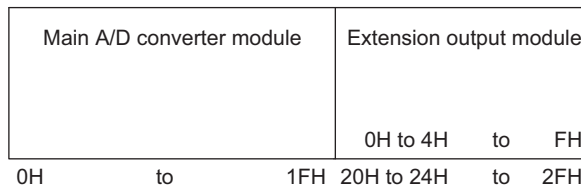

Remote output (RY) numbered 4H as counted from the head of the extension output module corresponds to Remote output (RY) numbered 24H as counted from the head of the main A/D converter module.

Thus, set 24H for Error flag assignment (address: 0005H).

(b) Enabling the setting

Turn on and off Initial data setting request flag (RY9) to enable the setting.

(c) Default value

The default value is No assignment (FFFFH).

(d) Remote buffer memory address

The remote buffer memory address of this area is as follows:

Remote buffer memory name	Main A/D converter module	Extension A/D converter module
Error flag assignment	0005H	—



Setting a value out of the range results in the error code (0173H) being stored in Latest error code (RWr0), Error flag (RXA) turning on, and the ERR. LED lighting up, with the previously set operation.

(7) Warning flag assignment

Assign Warning flag (RX7) to Remote output (RY) of the extension output module using the external signal assignment function. When a minor error occurs, assigned Remote output (RY) is turned on.

(a) Setting range

With the head of Remote output (RY) of the main A/D converter module as a starting point (0000H), set the device number for Remote output (RY) of the connected extension output module.

Ex. When Warning flag (RX7) is assigned to Remote output (RY) numbered 6H as counted from the head (0H) of the extension output module

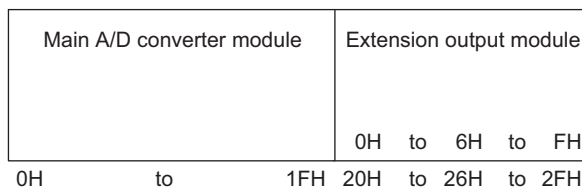

Remote output (RY) numbered 6H as counted from the head of the extension output module corresponds to Remote output (RY) numbered 26H as counted from the head of the main A/D converter module.

Thus, set 26H for Warning flag assignment (address: 0006H).

(b) Enabling the setting

Turn on and off Initial data setting request flag (RY9) to enable the setting.

(c) Default value

The default value is No assignment (FFFFH).

(d) Remote buffer memory address

The remote buffer memory address of this area is as follows:

Remote buffer memory name	Main A/D converter module	Extension A/D converter module
Warning flag assignment	0006H	—

Point

Setting a value out of the range results in the error code (0174H) being stored in Latest error code (RWr0), Error flag (RXA) turning on, and the ERR. LED lighting up, with the previously set operation.

(8) Cyclic data update watch time setting

This signal is used to set the time to monitor the data update interval of the cyclic transmission (watch time). A cyclic transmission stop state that persists over the cyclic data update watch time is regarded as being in disconnection, where the output status of the extension output module becomes HOLD (1H) or CLEAR (0H) according to Digital output HOLD/CLEAR setting (address: 0011H). For Digital output HOLD/CLEAR setting (address: 0011H), refer to the following:

- Digital output HOLD/CLEAR setting (☞ Page 214, Appendix 3 (10))

(a) Setting range

Setting range is Not monitor (0) or 0.1 to 2 seconds (1 to 20). Set the value in increments of 100ms (1).

(b) Enabling the setting

Turn on and off Initial data setting request flag (RY9) to enable the setting.

(c) Default value

The default value is Not monitor (0).

(d) Remote buffer memory address

The remote buffer memory address of this area is as follows:

Remote buffer memory name	Main A/D converter module	Extension A/D converter module
Cyclic data update watch time setting	0007H	—

Point

- Setting a value out of the range results in the error code (0930H) being stored in Latest error code (RWr0), Error flag (RXA) turning on, and the ERR. LED lighting up, with the I/O operation stopping.
- Synchronous communication mode ignores the set value, resulting in operation with Not monitor (0).

(9) Input response time setting

Set the input response time of the extension input module.

Input response time	Setting value
1.0ms	2H
1.5ms	3H
5ms	4H
10ms	5H
20ms	6H
70ms	7H

(a) Enabling the setting

Turn on and off Initial data setting request flag (RY9) to enable the setting.

(b) Default value

The default value is 10ms (5H).

(c) Remote buffer memory address

The remote buffer memory address of this area is as follows:

Remote buffer memory name	Main A/D converter module	Extension A/D converter module
Input response time setting	0010H	—

Point

- Setting data other than the above results in the error code (1F40H) being stored in Latest error code (RWr0), Error flag (RXA) turning on, and the ERR. LED lighting up.
- When no extension input module is connected, the setting of Input response time setting (address: 0010H) is ignored.

(10) Digital output HOLD/CLEAR setting

Set the output HOLD/CLEAR of the extension output module.

For the output HOLD/CLEAR setting function, refer to the following:

 CC-Link IE Field Network Remote I/O Module User's Manual

Output HOLD/CLEAR setting	Setting value
CLEAR	0H
HOLD	1H

(a) Enabling the setting

Turn on and off Initial data setting request flag (RY9) to enable the setting.

(b) Default value

The default value is CLEAR (0H).

(c) Remote buffer memory address

The remote buffer memory address of this area is as follows:

Remote buffer memory name	Main A/D converter module	Extension A/D converter module
Digital output HOLD/CLEAR setting	0011H	—

Point

- When no extension output module is connected, the setting of Digital output HOLD/CLEAR setting (address: 0011H) is ignored.
- Setting data other than the above results in operation with the set value of the lower 1 bit.

(11) A/D conversion enable/disable setting

Set whether to enable or disable A/D conversion for each channel.

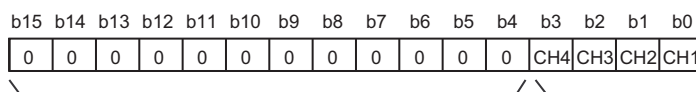

The values of b4 to b15 are fixed to 0.

0: A/D conversion enabled
1: A/D conversion disabled

(a) Enabling the setting

Turn on and off Initial data setting request flag (RY9) to enable the setting.

(b) Default value

The default value is Enabled (0) for all channels.

(c) Remote buffer memory address

The remote buffer memory addresses of this area are as follows:

Remote buffer memory name	Main A/D converter module				Extension A/D converter module			
	CH1	CH2	CH3	CH4	CH1	CH2	CH3	CH4
A/D conversion enable/disable setting	0102H				0202H			

(12) Range setting

Set the input range for each channel.

b15 to b12	b11 to b8	b7 to b4	b3 to b0
CH4	CH3	CH2	CH1

Input range	Setting value	
	Main A/D converter module	Extension A/D converter module
4 to 20mA	0H	0H
0 to 20mA	1H	1H
1 to 5V	2H	2H
0 to 5V	3H	3H
-10 to 10V	4H	4H
User range setting 1	5H	—
User range setting 2	6H	—

The range is not changed if A/D conversion enable/disable setting (address: 0102H, 0202H) is set to A/D conversion disabled. To change the range, set A/D conversion enable/disable setting (address: 0102H, 0202H) to A/D conversion enabled and turn on and off Initial data setting request flag (RY9).

(a) Enabling the setting

Turn on and off Initial data setting request flag (RY9) to enable the setting.

(b) Default value

The default value is 4 to 20mA (0H).

(c) Remote buffer memory address

The remote buffer memory addresses of this area are as follows:

Remote buffer memory name	Main A/D converter module				Extension A/D converter module			
	CH1	CH2	CH3	CH4	CH1	CH2	CH3	CH4
Range setting	0103H				0203H			

Point

Setting data other than the above results in the error code (010□H or 110□H) being stored in Latest error code (RW_r0), Error flag (RXA) turning on, and the ERR. LED turning on. A channel where data other than the above is set operates in the same way as when the A/D conversion is disabled.

(13) Averaging process specification

This area is used for setting sampling processing or selecting the type of averaging processing for each channel. There are the following types of averaging processing: time average, count average, and moving average.

b15 to b12	b11 to b8	b7 to b4	b3 to b0
CH4	CH3	CH2	CH1

Processing method	Setting value
Sampling processing	0H
Time average	1H
Count average	2H
Moving average	3H

(a) Enabling the setting

Turn on and off Initial data setting request flag (RY9) to enable the setting.

(b) Default value

The default value is Sampling processing (0H) for all channels.

(c) Remote buffer memory address

The remote buffer memory addresses of this area are as follows:

Remote buffer memory name	Main A/D converter module				Extension A/D converter module			
	CH1	CH2	CH3	CH4	CH1	CH2	CH3	CH4
Averaging process specification	0104H				0204H			

Point

- In the trigger conversion mode or synchronous communication mode, the setting of Averaging process setting (address: 0104H and 0204H) is ignored and the sampling processing is performed.
- A channel to which a value out of the above range is written operates with the sampling processing.

(14)CH□ Time average/Count average/Moving average

This area is used for setting the time average, count average, or moving average for each channel where the averaging processing is specified.

The following shows the setting range.

Processing method	Setting value
Time average ^{*1}	2 to 5000(ms)
Count average ^{*2}	4 to 65000 (times)
Moving average ^{*2}	2 to 128 (times)

*1 For time average, set a value of (4 × Sampling period) ms or more. A value less than this criterion results in the error code (020□H, 120□H) being stored in Latest error code (RWr0), Error flag (RXA) turning on, and the ERR. LED lighting up. In CH□ Digital operation value (RWr2 to RWr5, RWr12 to RWr15), 0 is stored.

*2 Setting data other than the above results in the error code (030□H and 130□H, or 031□H and 131□H) being stored in Latest error code (RWr0), Error flag (RXA) turning on, and the ERR. LED lighting up. The A/D conversion processing is performed with the settings just before the error.

(a) Enabling the setting

Turn on and off Initial data setting request flag (RY9) to enable the setting.

(b) Default value

The default value is 0 for all channels.

(c) Remote buffer memory address

The remote buffer memory addresses of this area are as follows:

Remote buffer memory name	Main A/D converter module				Extension A/D converter module			
	CH1	CH2	CH3	CH4	CH1	CH2	CH3	CH4
CH□ Time average/Count average/Moving average	0105H	0106H	0107H	0108H	0205H	0206H	0207H	0208H

Point

- By default, 0 is set and so change the value according to the processing method.
- For the channel where any value is set up, setting the sampling processing results in the set value being ignored.

(15) Input signal error detection setting

Set the condition for detecting an error of input signals for each channel.

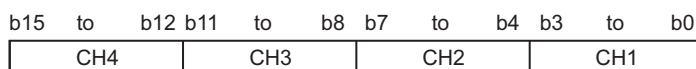

Detection method for input signal error	Setting value
Disable	0H
Disconnection detection	4H

(a) Enabling the setting

Turn on and off Initial data setting request flag (RY9) to enable the setting.

(b) Default value

The default value is Disable (0H) for all channels.

(c) Remote buffer memory address

The remote buffer memory addresses of this area are as follows:

Remote buffer memory name	Main A/D converter module				Extension A/D converter module			
	CH1	CH2	CH3	CH4	CH1	CH2	CH3	CH4
Input signal error detection setting	0109H				0209H			

Point

Disconnection detection (4H) is valid only when the input range is 1 to 5V or 4 to 20mA. Setting a channel with the other input ranges to Disconnection detection (4H) causes a disconnection detection setting error (error code: 082□H or 182□H).

(16) Alert output setting

Set whether to enable or disable the alert output of process alarm for each channel.

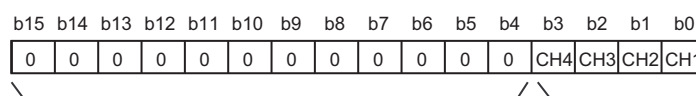

The values of b4 to b15 are fixed to 0.

0: Enabled
1: Disabled

(a) Enabling the setting

Turn on and off Initial data setting request flag (RY9) to enable the setting.

(b) Default value

The default value is Disable (1) for all channels.

(c) Remote buffer memory address

The remote buffer memory addresses of this area are as follows:

Remote buffer memory name	Main A/D converter module				Extension A/D converter module			
	CH1	CH2	CH3	CH4	CH1	CH2	CH3	CH4
Alert output setting	010EH				020EH			

(17) CH□ Process alarm lower lower limit value, CH□ Process alarm lower upper limit value, CH□ Process alarm upper lower limit value, CH□ Process alarm upper upper limit value

Set the range of digital operation value for each channel.

For details on Alert output function (process alarm), refer to the following:

- Alert Output Function (Process Alarm) ( Page 106, Section 8.10)

(a) Setting range

- Setting range is -32768 to 32767.
- The settings consist of the four items: process alarm upper upper limit value, process alarm upper lower limit value, process alarm lower upper limit value, and process alarm lower lower limit value.

(b) Enabling the setting

Turn on and off Initial data setting request flag (RY9) to enable the setting.

(c) Default value

The default value is 0.

(d) Remote buffer memory address

The remote buffer memory addresses of this area are as follows:

Remote buffer memory name	Main A/D converter module				Extension A/D converter module			
	CH1	CH2	CH3	CH4	CH1	CH2	CH3	CH4
CH□ Process alarm lower lower limit value	010FH	0113H	0117H	011BH	020FH	0213H	0217H	021BH
CH□ Process alarm lower upper limit value	0110H	0114H	0118H	011CH	0210H	0214H	0218H	021CH
CH□ Process alarm upper lower limit value	0111H	0115H	0119H	011DH	0211H	0215H	0219H	021DH
CH□ Process alarm upper upper limit value	0112H	0116H	011AH	011EH	0212H	0216H	021AH	021EH

Point

- An error occurs in a channel with a set value out of the range above or a set value not meeting the following condition: Process alarm upper upper limit value \geq Process alarm upper lower limit value \geq Process alarm lower upper limit value \geq Process alarm lower lower limit value. An error results in the error code (06△□H or 16△□H) being stored in Latest error code (RWr0), Error flag (RXA) turning on, and the ERR. LED lighting up, resulting in operation just before the error.
- By default, 0 is set and so change the set value.
- When the following functions are used, alert targets are digital operation values that reflect the operations of each function. Set values considering operation results of each function.
 - Digital clipping function
 - Scaling function
 - Shift function
 - Difference conversion function

(18) Digital clipping enable/disable setting

Set whether to enable or disable the digital clipping function for each channel.

For details on the digital clipping function, refer to the following:

- Digital Clipping Function (📖 Page 118, Section 8.13)

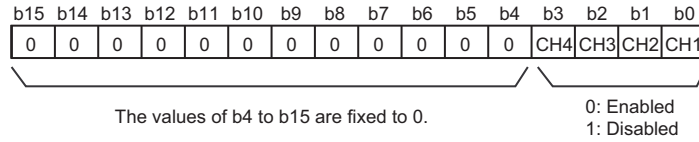

(a) Enabling the setting

Turn on and off Initial data setting request flag (RY9) to enable the setting.

(b) Default value

The default value is Disabled (1) for all channels.

(c) Remote buffer memory address

The remote buffer memory addresses of this area are as follows:

Remote buffer memory name	Main A/D converter module				Extension A/D converter module			
	CH1	CH2	CH3	CH4	CH1	CH2	CH3	CH4
Digital clipping enable/disable setting	011FH				021FH			

(19) Scaling enable/disable setting

Set whether to enable or disable scaling for each channel.

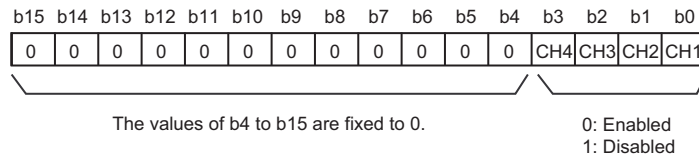

(a) Enabling the setting

Turn on and off Initial data setting request flag (RY9) to enable the setting.

(b) Default value

The default value is Disabled (1) for all channels.

(c) Remote buffer memory address

The remote buffer memory addresses of this area are as follows:

Remote buffer memory name	Main A/D converter module				Extension A/D converter module			
	CH1	CH2	CH3	CH4	CH1	CH2	CH3	CH4
Scaling enable/disable setting	0120H				0220H			

(20)CH□ Scaling lower limit value, CH□ Scaling upper limit value

Set the range of scale conversion for each channel.

For details on the scaling function, refer to the following:

- Scaling Function (🔍 Page 109, Section 8.11)

(a) Setting range

Setting range: -32000 to 32000 (scaling upper limit value > scaling lower limit value)

(b) Enabling the setting

Turn on and off Initial data setting request flag (RY9) to enable the setting.

(c) Default value

The default value is 0 for all channels.

(d) Remote buffer memory address

The remote buffer memory addresses of this area are as follows:

Remote buffer memory name	Main A/D converter module				Extension A/D converter module			
	CH1	CH2	CH3	CH4	CH1	CH2	CH3	CH4
CH□ Scaling lower limit value	0121H	0123H	0125H	0127H	0221H	0223H	0225H	0227H
CH□ Scaling upper limit value	0122H	0124H	0126H	0128H	0222H	0224H	0226H	0228H

Point

- An error occurs in a channel with a set value out of the range or a set value not meeting the following condition: Scaling upper limit value > Scaling lower limit value. An error results in the error code (090□H and 190□H, or 091□H and 191□H) being stored in Latest error code (RWr0), Error flag (RXA) turning on and the ERR. LED lighting up, resulting operation just before the error.
- By default, 0 is set and so change the set value.
- With Scaling enable/disable setting (address: 0120H, 0220H) set to Disabled (1), the settings of the following areas are ignored:
 - CH□ Scaling lower limit value
 - CH□ Scaling upper limit value

(21)CH□ Maximum value, CH□ Minimum value

The maximum and minimum values of converted digital operation value are stored as signed 16-bit binary. See below for reset.

- Turning on and off Maximum value/minimum value reset request (RY1D) of the main A/D converter module results in CH□ Maximum value and CH□ Minimum value of the main A/D converter module being updated to the current value.
- Turning on and off Maximum value/minimum value reset request (RY2D) of the extension A/D converter module results in CH□ Maximum value and CH□ Minimum value of the extension A/D converter module being updated to the current value.
- Turning on and off Initial data setting request flag (RY9) results in CH□ Maximum value and CH□ Minimum value of both the main A/D converter module and the extension A/D converter module being updated to the current value.

(a) Remote buffer memory address

The remote buffer memory addresses of this area are as follows:

Remote buffer memory name	Main A/D converter module				Extension A/D converter module			
	CH1	CH2	CH3	CH4	CH1	CH2	CH3	CH4
CH□ Maximum value	0601H	0603H	0605H	0607H	0701H	0703H	0705H	0707H
CH□ Minimum value	0602H	0604H	0606H	0608H	0702H	0704H	0706H	0708H

Point

- With the averaging processing specified, the maximum and minimum values are updated per averaging process cycle; otherwise, updated per sampling cycle.
- With the following functions used, values computed by each function are stored in the maximum value and the minimum value:
 - Digital clipping function
 - Scaling function
 - Shift function
 - Difference conversion function

(22)Extension module identification code

The identification code for a connected extension module is stored.

If the extension A/D converter module is connected, 2111H is stored.

For the identification code for extension modules other than the extension A/D converter module, refer to the following:

 Manual including the description of the extension module used

(a) Remote buffer memory address

The remote buffer memory address of this area is as follows:

Remote buffer memory name	Main A/D converter module	Extension A/D converter module
Extension module identification code	—	0700H

(23) Error history data

Up to 15 errors occurred in the module are recorded.

The following table and figure show the storage contents for Error history 1 (address: 0A00H to 0A0FH).

	b15	to	b8	b7	to	b0
0A00H	Error code					
0A01H	Number of chronological order					
0A02H	First two digits of year			Last two digits of year		
0A03H	Month			Day		
0A04H	Hour			Minute		
0A05H	Second			00H (fixed)		
0A06H	CH1 Digital operation value					
0A07H	CH2 Digital operation value					
0A08H	CH3 Digital operation value					
0A09H	CH4 Digital operation value					
0A0AH to 0A0FH	System area					

Item	Storage contents	Storage example ^{*1}
Error code	The error code of the error that occurred is stored.	—
Order of generation	The order of error occurrence is stored. (A value in the range of 0 to 65535 is stored.)	0001H
First two digits of the year/Last two digits of the year ^{*2}	The items on the left are stored in BCD code.	2014H
Month/Date ^{*2}		1101H
Hour/Minute ^{*2}		1330H
Second/00H (Fixed) ^{*2}		5000H
CH1 Digital operation value		The value in CH□ Digital operation value (RWr2 to RWr5, RWr12 to RWr15) at the time of occurrence of an error is stored.
CH2 Digital operation value		
CH3 Digital operation value		
CH4 Digital operation value		

*1 This example assumes that a second error has occurred at 13:30:50 on November 1, 2014.

*2 The clock information of the error that occurred is based on the clock information acquired from the CPU module of the master station.

When an error has occurred before the clock information is acquired from the CPU module, the error time is not recorded.

Error history 2 to Error history 15 (address: 0A10H to 0AEFH) are stored in the same format as that of Error history 1 (address: 0A00H to 0A0FH).

For the error code, refer to the following:

- Error Code List (Page 173, Section 11.2)

(a) Storage order of the error history

The latest error is stored in Error history 1 (address: 0A00H to 0A0FH).

Errors that occurred in the past are stored in Error history 2 to Error history 15 (address: 0A10H to 0AEFH) in reverse chronological order.

If 16 or more errors occur, errors are deleted from the oldest.

(b) Remote buffer memory address

The remote buffer memory addresses of this area are as follows:

Remote buffer memory name	Main A/D converter module	Extension A/D converter module
Error history data□	0A00H to 0AEFH	

(24) Error history clear command

This command is used to clear the error history stored in the non-volatile memory.

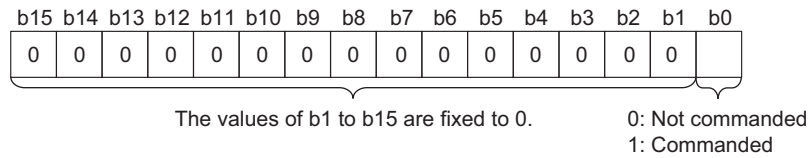

(a) Behavior of error history clear

Setting Error history clear command (address: 1000H) to Commanded (1) allows the error history to be cleared.

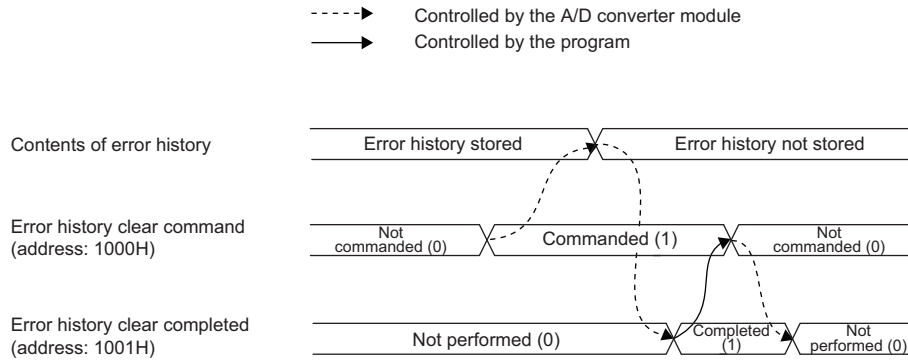

(b) Default value

The default value is Not commanded (0).

(c) Remote buffer memory address

The remote buffer memory address of this area is as follows:

Remote buffer memory name	Main A/D converter module	Extension A/D converter module
Error history clear command	1000H	—

(25) Error history clear completed

This remote buffer memory shows the error history clear completed status stored in the non-volatile memory.

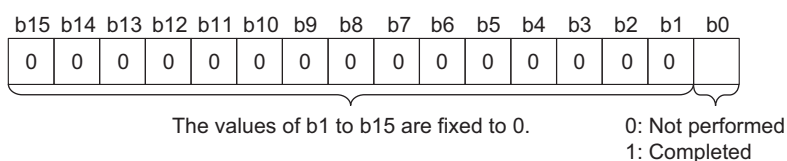
**(a) Behavior of error history clear**

Upon completion of the error history clear, Error history clear completed (address: 1001H) turns to Completed (1).

For the timing "Not performed (0)→Completed (1)→Not performed (0)", refer to the following:

- Error history clear command (📄 Page 224, Appendix 3 (24))

(b) Default value

The default value is Not performed (0).

(c) Remote buffer memory address

The remote buffer memory address of this area is as follows:

Remote buffer memory name	Main A/D converter module	Extension A/D converter module
Error history clear completed	1001H	—

(26)Parameter area initialization command

This command is used to set parameters in remote buffer memory areas and non-volatile memory to a default value.

In the event of a non-volatile memory data error (parameter) (error code: 0130H), using this command makes it possible to recover the module.

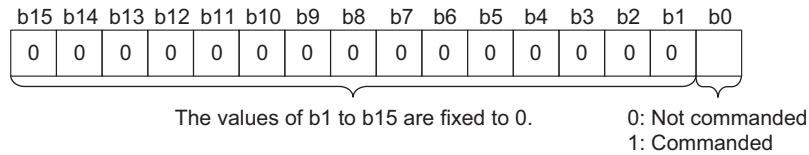

(a) Behavior of parameter area initialization

Setting Parameter area initialization command (address:1002H) to Commanded (1) sets the parameters in the non-volatile memory back to default values.

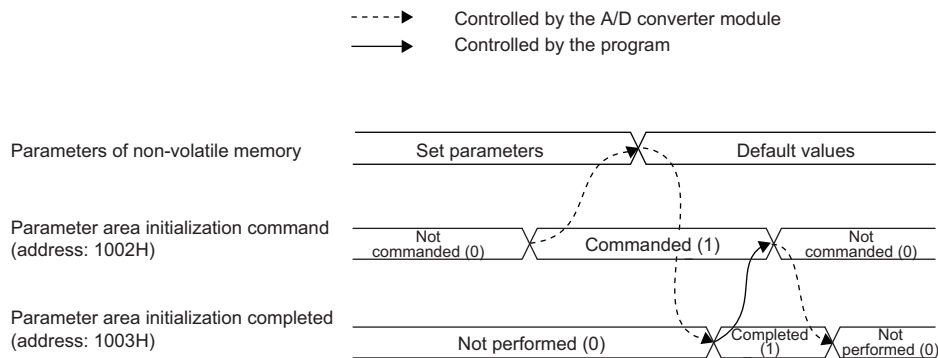

(b) Default value

The default value is Not commanded (0).

(c) Remote buffer memory address

The remote buffer memory address of this area is as follows:

Remote buffer memory name	Main A/D converter module	Extension A/D converter module
Parameter area initialization command	1002H	—

Point

An execution of Parameter area initialization command (address: 1002H) does not clear the following remote input signals and remote registers:

- Warning flag (RX7)
- Error flag (RXA)
- Alert output signal (RX18, RX28)
- Input signal error detection signal (RX1C, RX2C)

In addition, Remote READY (RXB) does not turn on.

After the execution of Parameter area initialization command (address: 1002H), turning off and on the module power supply enables the module to operate normally.

(27)Parameter area initialization completed

This memory area shows whether the parameters stored in the non-volatile memory is initialized or not.

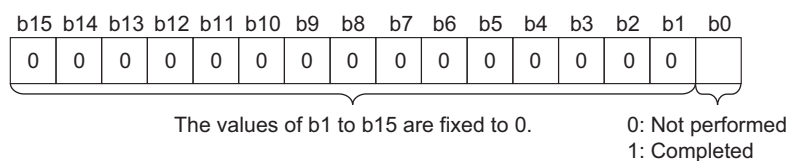

(a) Behavior of parameter area initialization

Upon the completion of setting the parameters stored in the non-volatile memory back to their default values, Parameter area initialization completed (address: 1003H) turns to Completed (1). For the timing "Not performed (0)→Completed (1)→Not performed (0)", refer to the following:

- Parameter area initialization command ( Page 226, Appendix 3 (26))

(b) Default value

The default value is Not performed (0).

(c) Remote buffer memory address

The remote buffer memory address of this area is as follows:

Remote buffer memory name	Main A/D converter module	Extension A/D converter module
Parameter area initialization completed	1003H	—

(28) Module operation information initialization command

This command is used to clear the module operation information stored in the non-volatile memory. Initialization of the module operation information is permitted provided that a non-volatile memory data error (module operation information) (error code: 0110H) occurs.

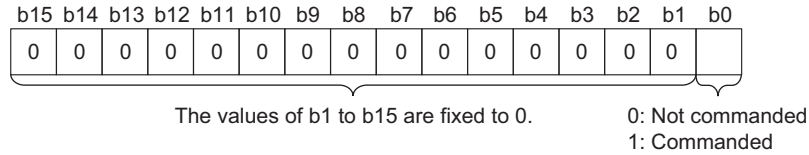

(a) Behavior of module operation information initialization

Setting Module operation information initialization command (address: 1004H) to Commanded (1) allows the module operation information to be initialized.

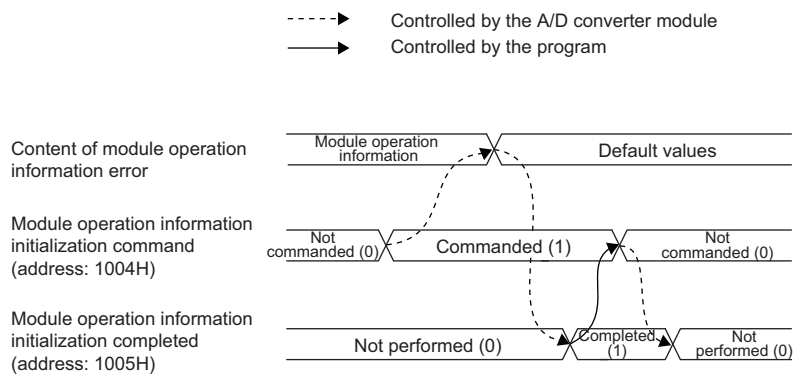

(b) Default value

The default value is Not commanded (0).

(c) Remote buffer memory address

The remote buffer memory address of this area is as follows:

Remote buffer memory name	Main A/D converter module	Extension A/D converter module
Module operation information initialization command	1004H	—

(29) Module operation information initialization completed

This memory area shows whether the module operation information stored in the non-volatile memory is initialized or not.

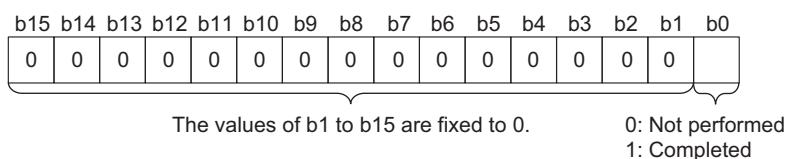

(a) Behavior of module operation information initialization

Upon the completion of initializing the module operation information, Module operation information initialization completed (address: 1005H) turns to Completed (1).

For the timing "Not performed (0) → Completed (1) → Not performed (0)", refer to the following:

- Module operation information initialization command ( Page 228, Appendix 3 (28))

(b) Default value

The default value is Not performed (0).

(c) Remote buffer memory address

The remote buffer memory address of this area is as follows:

Remote buffer memory name	Main A/D converter module	Extension A/D converter module
Module operation information initialization completed	1005H	—

Appendix 4 I/O Conversion Characteristics of A/D Conversion

The I/O conversion characteristics of A/D conversion are expressed by the slope of the straight line connecting the offset value and the gain value, both of which are used when an analog signal from outside the programmable controller (voltage or current input) is converted to the corresponding digital value.

(1) Offset value

An analog input value (voltage or current) which turns 0 as a digital output value after conversion

(2) Gain value

An analog input value (voltage or current) which turns 16000 as a digital output value after conversion

(3) Voltage input characteristics

The following graph shows the voltage input characteristics.

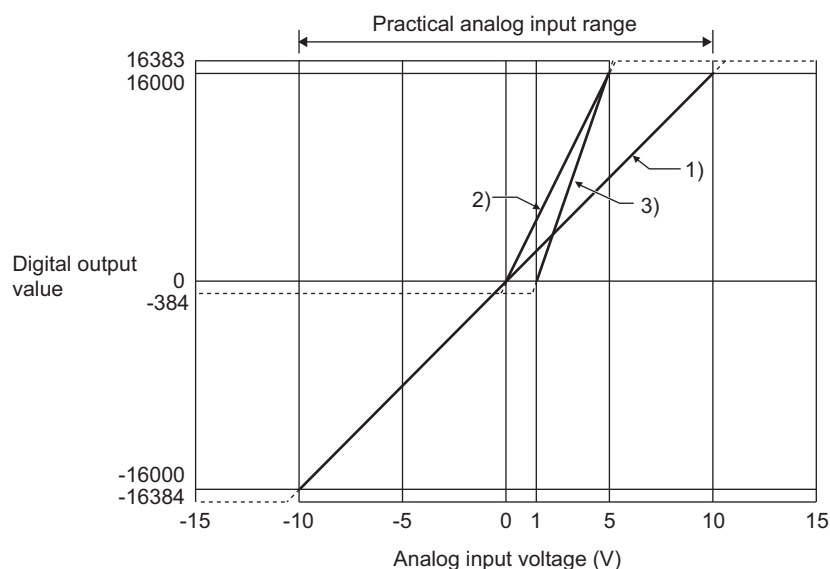

No.	Input range setting	Offset value	Gain value	Digital output value ^{*2}	Maximum resolution
1)	-10 to 10V	0V	10V	-16000 to 16000	0.625mV
—	User range setting 1 ^{*3} (-10 to 10V)	*1	*1	-16000 to 16000	0.5mV
—	User range setting 2 ^{*3} (-5 to 5V)	*1	*1	-16000 to 16000	0.25mV
2)	0 to 5V	0V	5V	0 to 16000	0.3125mV
3)	1 to 5V	1V	5V	0 to 16000	0.25mV

*1 Set the offset value and gain value in the user range setting within the range satisfying the following conditions. If the following conditions are not satisfied, A/D conversion may not be properly performed.

<User range setting 1>

- Setting range for offset value and gain value: -10 to 10V
- ((Gain value) - (Offset value)) ≥ 8.0V
- 10.433V ≥ (Gain value - (Offset value × 2))

<User range setting 2>

- Setting range for offset value and gain value: -5 to 5V
- ((Gain value) - (Offset value)) ≥ 4.0V
- 5.21V ≥ (Gain value - (Offset value × 2))

*2 When the analog input value exceeds the range of digital output values, the digital output value is fixed to the maximum or minimum value.

Input range setting	Digital output value	
	Minimum	Maximum
-10 to 10V	-16384	16383
User range setting 1 (-10 to 10V) ^{*3}		
User range setting 2 (-5 to 5V) ^{*3}		
0 to 5V	-384	
1 to 5V		

*3 The extension A/D converter module does not support User range 1 and User range 2.

- Use the value within the practical analog input range and practical digital output range. If a value is out of the range, the maximum resolution and accuracy may not fall within the range of performance specifications. (Do not use the value in the dotted line region in the graph of voltage input characteristics.)
- Do not set the voltage over $\pm 15V$. Doing so can cause breakdown of the elements.

(4) Current input characteristics

The following graph shows the current input characteristics.

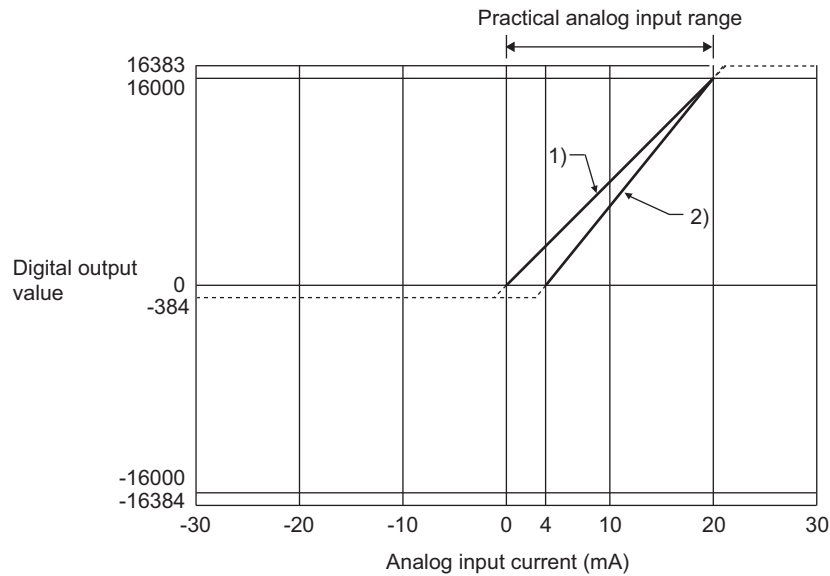

No.	Input range setting	Offset value	Gain value	Digital output value ^{*2}	Maximum resolution
1)	0 to 20mA	0mA	20mA	0 to 16000	1.25 μ A
2)	4 to 20mA	4mA	20mA		1 μ A
—	User range setting 2 ^{*3} (-20 to 20mA)	*1	*1	-16000 to 16000	1 μ A

*1 Set the offset value and gain value in the user range setting within the range satisfying the following conditions. If the following conditions are not satisfied, A/D conversion may not be properly performed.

- Gain value $\leq 20mA$, offset value $\geq -20mA$
- $((\text{Gain value}) - (\text{Offset value})) \geq 16mA$
- $20.84mA \geq (\text{Gain value} - (\text{Offset value} \times 2))$

*2 When the analog input value exceeds the range of digital output values, the digital output value is fixed to the maximum or minimum value.

Input range setting	Digital output value	
	Minimum	Maximum
0 to 20mA	-384	16383
4 to 20mA		
User range setting 2 ^{*3} (-20 to 20mA)	-16384	

*3 The extension A/D converter module does not support User range 2.

- Use the value within the practical analog input range and practical digital output range. If a value is out of the range, the maximum resolution and accuracy may not fall within the range of performance specifications. (Do not use the value in the dotted line region in the graph of current input characteristics.)
- Do not set the voltage over $\pm 30mA$. Doing so can cause breakdown of the elements.

Appendix 5 Accuracy of A/D Conversion

Accuracy of A/D conversion is the accuracy for the maximum value of digital output value.

An input characteristic change caused by changing the offset/gain setting and the input range does not sacrifice the accuracy, which is maintained within the described range of the performance specifications.

The following graph shows the fluctuation range of accuracy with the range of -10 to 10V selected.

The accuracy of digital output is $\pm 0.1\%$ (± 16 digits) at an ambient temperature of $25\pm 5^\circ\text{C}$; $\pm 0.2\%$ (± 32 digits) at an ambient temperature of 0 to 55°C (except for the conditions under noise influence).

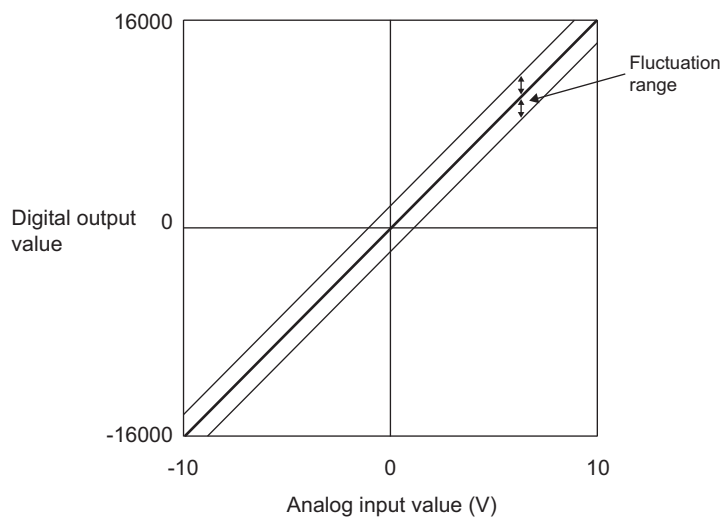

Appendix 6 Processing Time of CC-Link IE Field Network

The processing time of CC-Link IE Field Network is the time taken for the A/D converter module to take in analog input values and store the data into devices of the CPU module at the master station.

The processing time of CC-Link IE Field Network depends on the following processing time:

- Sequence scan time of the master station
- Link scan time
- Processing time of the remote device station: sampling period (☞ Page 91, Section 8.5.1)

For details on the processing time of CC-Link IE Field Network, refer to the following:

 User's manual for the master/local module used

Appendix 7 EMC and Low Voltage Directives

Compliance to the EMC Directive, which is one of the EU Directives, has been a legal obligation for the products sold in European countries since 1996 as well as the Low Voltage Directive since 1997.

Manufacturers who recognize their products are compliant to the EMC and Low Voltage Directives are required to attach a "CE mark" on their products.

(1) Sales representative in EU member states

Authorized representative in EU member states is shown below.

Name: Mitsubishi Electric Europe BV

Address: Gothaer Strasse 8, 40880 Ratingen, Germany

Appendix 7.1 Measures to comply with the EMC Directive

The EMC Directive specifies that "products placed on the market must be so constructed that they do not cause excessive electromagnetic interference (emissions) and are not unduly affected by electromagnetic interference (immunity)".

This section summarizes the precautions on compliance with the EMC Directive of the machinery constructed with the module.

These precautions are based on the requirements and the standards of the regulation, however, it does not guarantee that the entire machinery constructed according to the descriptions will comply with abovementioned directives.

The method and judgement for complying with the EMC Directive must be determined by the person who constructs the entire machinery.

(1) EMC Directive related standards

(a) Emission requirements

Specification	Test item	Test details	Standard value
EN61131-2: 2007	CISPR16-2-3 Radiated emission ^{*2}	Radio waves from the product are measured.	<ul style="list-style-type: none"> • 30M to 230MHz QP: 40dBμV/m (measured over 10m)^{*1} • 230M to 1000MHz QP: 47dBμV/m (measured over 10m)
	CISPR16-2-1, CISPR16-1-2 Conducted emission ^{*2}	Noise from the product to the power line is measured.	<ul style="list-style-type: none"> • 150k-500kHz QP: 79dB, Mean: 66dB^{*1} • 500k-30MHz QP: 73dB, Mean: 60dB

*1 QP (Quasi-Peak): quasi-peak value, Mean: mean value

*2 The module is an open type device (a device designed to be housed in other equipment) and must be installed inside a conductive control panel. The tests were conducted with the module installed in a control panel.

(b) Immunity requirements

Specification	Test item	Test details	Standard value
EN61131-2: 2007	EN61000-4-2 Electrostatic discharge immunity ^{*1}	Immunity test in which electrostatic is applied to the cabinet of the equipment.	<ul style="list-style-type: none"> • 8kV air discharge • 4kV contact discharge
	EN61000-4-3 Radiated, radio-frequency, electromagnetic field immunity ^{*1}	Immunity test in which electric fields are irradiated to the product.	<ul style="list-style-type: none"> • 80% AM modulation@1kHz • 80M-1000MHz: 10V/m • 1.4G-2.0GHz: 3V/m • 2.0G-2.7GHz: 1V/m
	EN61000-4-4 Electrical fast transient/burst immunity ^{*1}	Immunity test in which burst noise is applied to the power line and signal line.	<ul style="list-style-type: none"> • AC/DC main power, I/O power, AC I/O (unshielded): 2kV • DC I/O, analog, communication: 1kV
	EN61000-4-5 Surge immunity ^{*1}	Immunity test in which lightning surge is applied to the power line and signal line.	<ul style="list-style-type: none"> • AC power line, AC I/O power, AC I/O (unshielded): 2kV CM, 1kV DM • DC power line, DC I/O power: 0.5kV CM, DM • DC I/O, AC I/O (shielded), analog^{*2}, communication: 1kV CM
	EN61000-4-6 Immunity to conducted disturbances, induced by radio-frequency fields ^{*1}	Immunity test in which high frequency noise is applied to the power line and signal line	<ul style="list-style-type: none"> • 0.15M-80MHz, • 80% AM modulation @1kHz, 10Vrms
	EN61000-4-8 Power-frequency magnetic field immunity ^{*1}	Immunity test in which the product is installed in inductive magnetic field	<ul style="list-style-type: none"> • 50Hz/60Hz, 30A/m
	EN61000-4-11 Voltage dips and interruption immunity ^{*1}	Immunity test in which power supply voltage is momentarily interrupted	<ul style="list-style-type: none"> • Apply at 0%, 0.5 cycles and zero-cross point • 0%, 250/300 cycles (50/60Hz) • 40%, 10/12 cycles (50/60Hz) • 70%, 25/30 cycles (50/60Hz)

*1 The module is an open type device (a device designed to be housed in other equipment) and must be installed inside a conductive control panel. The tests were conducted with the module installed in a control panel.

*2 The accuracy of an analog-digital converter module can indicate momentary fluctuation within $\pm 10\%$.

(2) Installation in a control panel

The module is open type devices and must be installed inside a control panel.

This ensures safety as well as effective shielding of programmable controller-generated electromagnetic noise.

(a) Control panel

- Use a conductive control panel.
- When securing the top or bottom plate using bolts, cover the grounding part on the control panel so that the part will not be painted.
- To ensure electrical contact between the inner plate and control panel, take measures such as covering the bolts so that conductivity can be ensured in the largest possible area.
- Ground the control panel with a thick ground cable so that low impedance can be ensured even at high frequencies.
- Holes in the control panel must be 10cm diameter or less. If the holes are larger than 10cm, radio wave may be emitted. In addition, because radio waves leak through a clearance between the control panel and its door, reduce the clearance as much as possible. The leakage of radio waves can be suppressed by the direct application of an EMI gasket on the paint surface.
- Our tests have been carried out on a control panel having the attenuation characteristics of 37dB (max.) and 30dB (mean) (measured by 3m method, 30 to 300MHz).

(b) Wiring of power cables and ground cables

- Near the power supply part, provide a ground point to the control panel. Ground the FG terminal with the thickest and shortest possible ground cable (30cm or shorter).

(3) Cables

Use shielded cables for the cables which are connected to the module and run out from the control panel. If a shielded cable is not used or not grounded correctly, the noise immunity will not meet the specified value.

(a) Cables for the CC-Link IE Field Network

The precautions for using CC-Link IE Field Network cables are as follows:

- CC-Link IE Field Network cables are made up of shielded wires. Strip a part of the jacket as shown below and ground the exposed shield in the largest possible area.

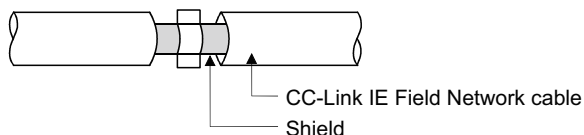

(b) Grounding the cable clamp

Use shielded cables for external wiring and ground the shields of the external wiring cables to the control panel with the AD75CK-type cable clamp (Mitsubishi). (Ground the shield section 20 to 30cm away from the module.)

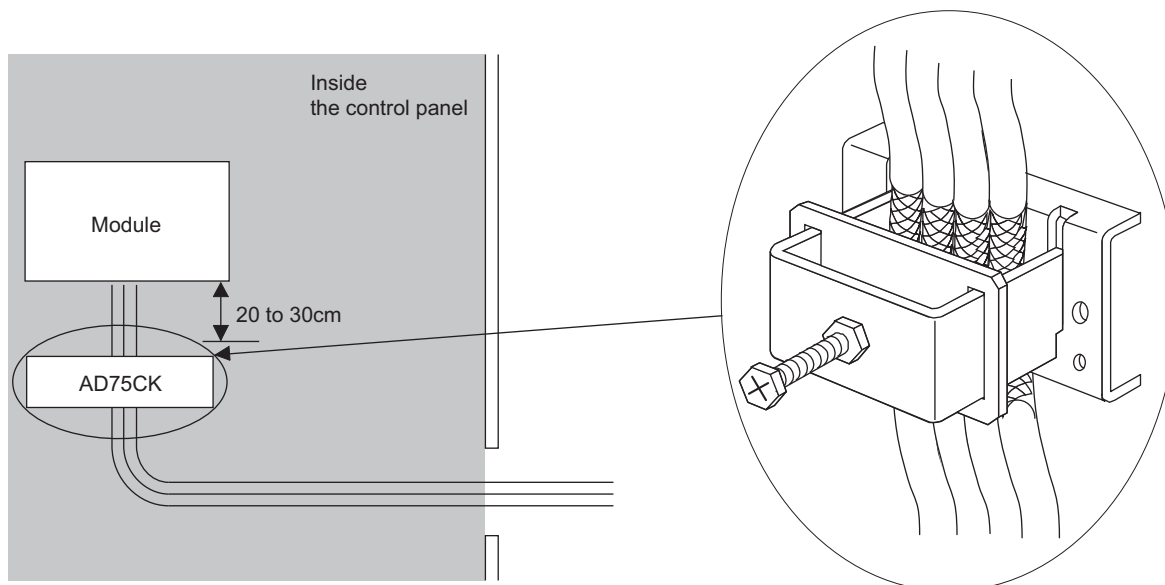

For details of the AD75CK, refer to the following:

📖 AD75CK-type Cable Clamping Instruction Manual

(c) Analog I/O signal line

Use a signal line of 30m or shorter when connecting it to the analog I/O terminals of the module.

(4) External power supply

- Use a CE-marked product for an external power supply and always ground the FG terminal. (External power supply used for the tests conducted by Mitsubishi: TDK-Lambda DLP-120-24-1, IDEC PS5R-SF24, PS5R-F24)
- Use a power cable of 10m or shorter when connecting it to the module power supply terminal.

(5) Others

(a) Ferrite core

A ferrite core has the effect of reducing radiated noise in the 30MHz to 100MHz band.

It is recommended to attach ferrite cores if shielded cables coming out of the control panel do not provide sufficient shielding effects.

Note that the ferrite cores must be attached at the position closest to the cable hole inside the control panel. If attached at an improper position, the ferrite core will not produce any effect.

For the FG terminal on a main module that is connected to the external power supply, the external power supply of an extension module, and CC-Link IE Field Network cables, attach a ferrite core 4cm away from the module.

(Ferrite core used for the tests conducted by Mitsubishi: NEC TOKIN ESD-SR-250, TDK ZCAT3035-1330)

Example

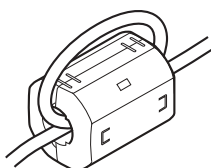

(b) Noise filter (power supply line filter)

A noise filter is a component which has an effect on conducted noise. Attaching the filter can suppress more noise. (The noise filter has the effect of reducing conducted noise of 10MHz or less.)

Connect a noise filter to the external power supply of a main module and the external power supply of an extension module. Use a noise filter with the damping characteristics equivalent to those of MA1206 (manufactured by TDK-Lambda Corporation). Note that a noise filter is not required if the module is used in Zone A defined in EN61131-2.

The precautions for attaching a noise filter are described below.

- Do not bundle the cables on the input side and output side of the noise filter. If bundled, the output side noise will be induced into the input side cables from which the noise was filtered.

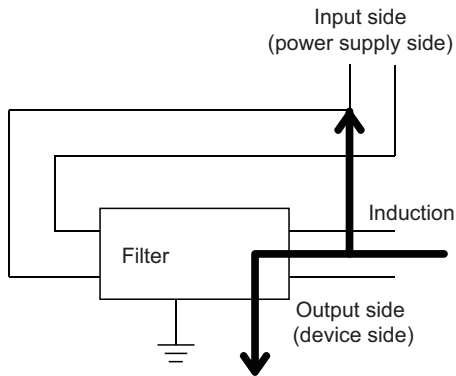

Noise is induced if an input line and an output line are bundled.

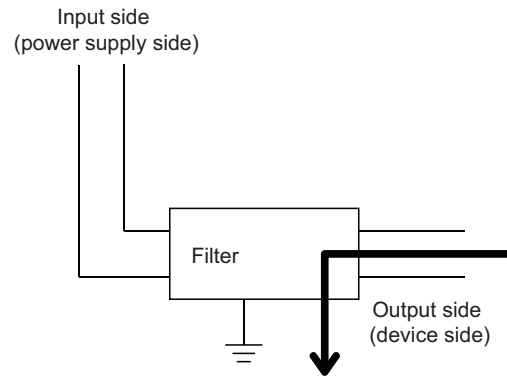

Arrange the wires with the input lines and the output lines separated.

- Ground the noise filter grounding terminal to the control panel with the shortest cable possible (approx. 10cm).

Appendix 7.2 Requirements to compliance with the Low Voltage Directive

A

The module operates at the rated voltage of 24VDC.

The Low Voltage Directive is not applied to the modules that operate at the rated voltage of less than 50VAC and 75VDC.

Appendix 8 How to Check Serial Number and Function Version

The serial number and function version of the A/D converter module can be checked on the rating plate. The serial number can be also checked from production information in CC-Link IE Field Network diagnostics.

(1) Checking on the rating plate

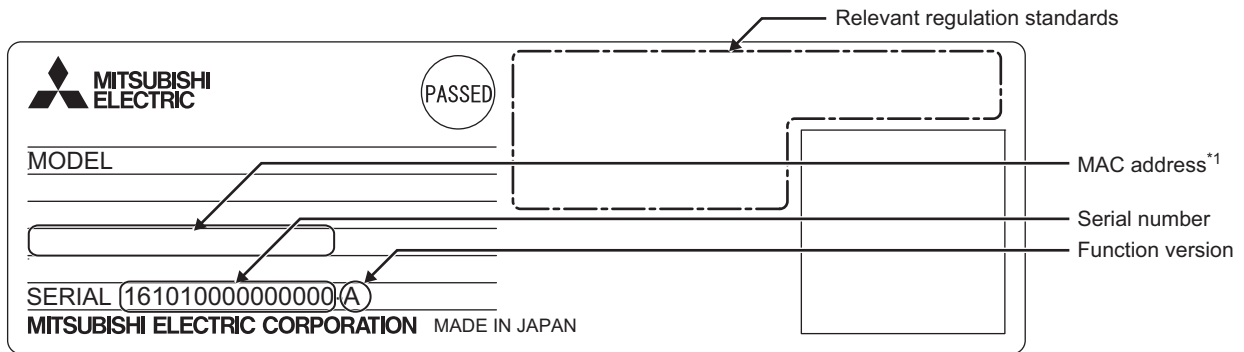

*1 The extension A/D converter module does not have a MAC address.

(2) Checking by using CC-Link IE Field Network diagnostics

1. Connect GX Works2 to the CPU module.
2. Start CC-Link IE Field Network diagnostics from the menu of GX Works2.
 - [Diagnostics] ⇒ [CC IE Field Diagnostics]
3. Right-click the slave station whose production information to be displayed, and select "Production Information".

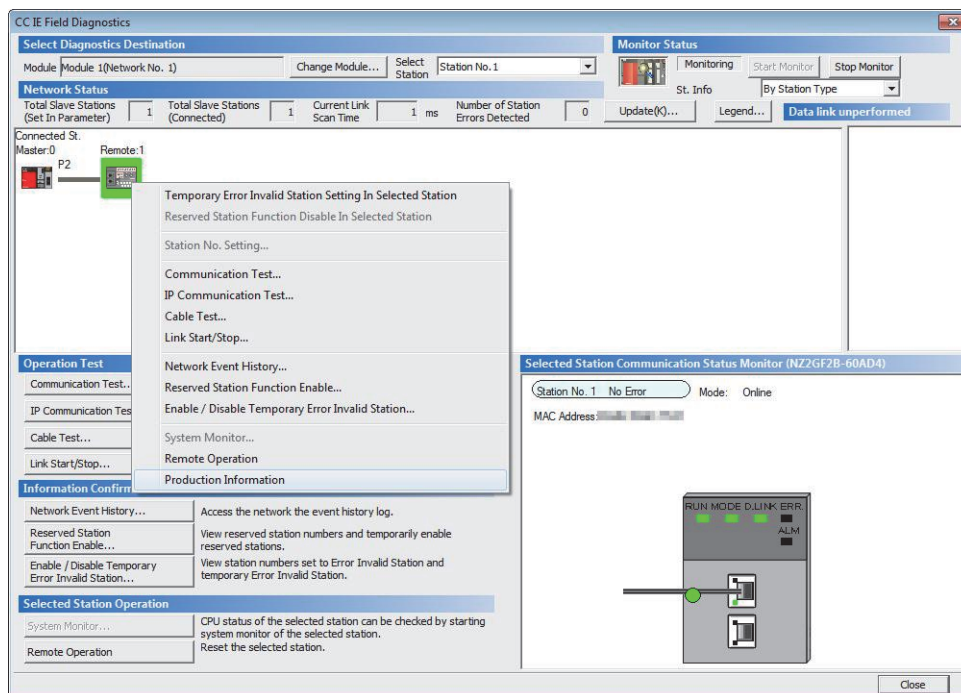

4. The production information appears.

The production information shows the serial number written on the rating plate.

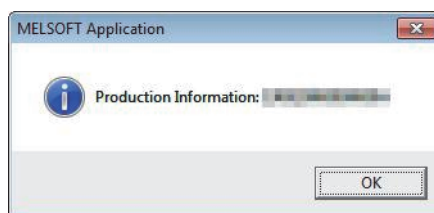

Appendix 9 Comparison with NZ2GF2B-60AD4

Appendix 9.1 Comparison of performance specifications

The following table shows the differences in the performance specifications between the NZ2GF2BN-60AD4 and the NZ2GF2B-60AD4.

Item		NZ2GF2BN-60AD4	NZ2GF2B-60AD4
Accuracy	Ambient temperature (25±5°C)	±0.1%	±0.2%
	Ambient temperature (0 to 55°C)	±0.2%	
Conversion speed		<ul style="list-style-type: none"> • 100µs/channel • 400µs/channel • 1ms/channel 	<ul style="list-style-type: none"> • 400µs/channel • 1ms/channel
External power supply		24VDC (20.4 to 28.8VDC) Inrush current: 36.5A, 1ms or lower Current consumption: 210mA	24VDC (20.4 to 28.8VDC) Inrush current: 31.2A (for 1.5ms or shorter) Current consumption: 230mA

Appendix 9.2 Functional comparison

The following table shows the differences in the functions between the NZ2GF2BN-60AD4 and the NZ2GF2B-60AD4.

Item	NZ2GF2BN-60AD4	NZ2GF2B-60AD4
Conversion speed switch function	Allows switching into the following conversion speeds: <ul style="list-style-type: none"> • 100µs/channel • 400µs/channel • 1ms/channel 	Allows switching into the following conversion speeds: <ul style="list-style-type: none"> • 400µs/channel • 1ms/channel
Speed switching of the trigger conversion function	Allows switching between 100µs/channel and 400µs/channel	Not available
Conversion speed switching of the CC-Link IE Field Network synchronous communication function	Allows switching between 100µs/channel and 400µs/channel	Not available
Support for extension modules	The following extension modules can be mounted: <ul style="list-style-type: none"> • Extension input module • Extension output module • Extension A/D converter module • Extension D/A converter module 	The following extension modules can be mounted: <ul style="list-style-type: none"> • Extension input module • Extension output module

Appendix 9.3 About replacement from NZ2GF2B-60AD4 to NZ2GF2BN-60AD4

This section describes the information on replacing the NZ2GF2B-60AD4 with the NZ2GF2BN-60AD4.

(1) Integration into the existing system

The terminal blocks of the NZ2GF2B-60AD4 can be installed into the NZ2GF2BN-60AD4 with the wiring left unchanged.

(2) Reusing the programs

Programs running in the NZ2GF2B-60AD4 can be reused as they are.

(3) Precautions when replacing the NZ2GF2B-60AD4 with a serial number (first five digits) of 15101 or earlier

The NZ2GF2B-60AD4 with a serial number (first five digits) of 15101 or earlier is the module designed before the addition of the CC-Link IE Field Network synchronous communication function. The remote buffer memory therefore differs in the following:

Item	NZ2GF2B-60AD4 (First five digits of the serial number are 15101 or earlier.)	NZ2GF2B-60AD4 (First five digits of the serial number are 15102 or later.), NZ2GF2BN-60AD4
Setting values of Mode switch (address: 0000H)	"0: Normal conversion mode" (default value) "1: Trigger conversion mode"	"0: Normal conversion mode" "1: Trigger conversion mode" "9: Automatical judgment mode" (default value)

For the NZ2GF2BN-60AD4, Mode switch (address: 0000H) is set to "9: Automatical judgment mode" by default. Hence, if the default value is left, using a master station that supports the CC-Link IE Field Network synchronous communication function results in the NZ2GF2BN-60AD4 operating in synchronous communication mode. To operate the NZ2GF2BN-60AD4 in normal mode, change the set value of its Mode switch (address: 0000H) to "0: Normal conversion mode".

Appendix 10 External Dimensions

Appendix 10.1 Main A/D converter module

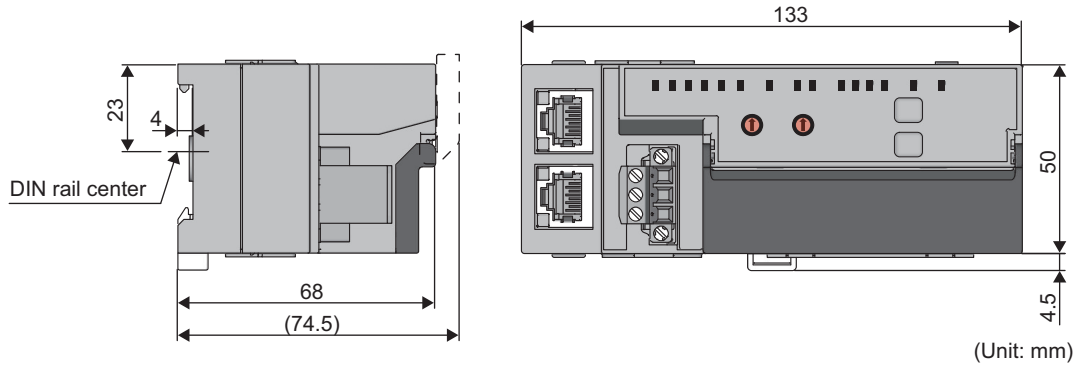

Appendix 10.2 Extension A/D converter module

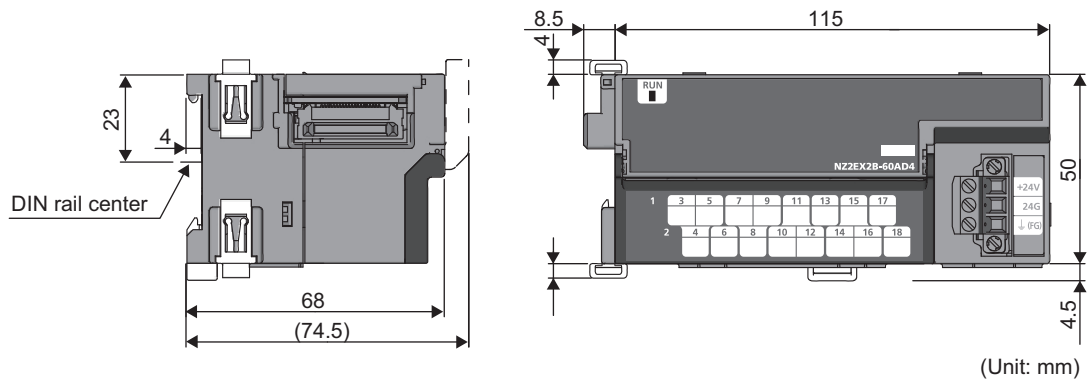

INDEX

A

A/D conversion enable/disable function	90
A/D conversion enable/disable setting	214
A/D conversion method	96
Alarm code list	181
Alert output flag	204
Alert output function (process alarm)	106
Alert output setting	218
Alert output signal	194
Alert output signal assignment	209
ALM LED	21
Applicable DIN rail model (compliant with IEC 60715)	58
Applicable systems	49
Application	15
Averaging process specification	216
Averaging processing	96

B

Bending radius of an Ethernet cable	63
-------------------------------------	----

C

Cables	238
CC-Link IE Field Network diagnostic function	153
CC-Link IE Field Network synchronous communication function	136
CH1 to CH4 A/D conversion completed flag	193
CH1 to CH4 Conversion value shift amount	204
CH1 to CH4 Difference conversion reference value	203
CH1 to CH4 Difference conversion state flag	193
CH1 to CH4 Difference conversion trigger	200
CH1 to CH4 Digital operation value	202
CH1 to CH4 LED	21
CH1 to CH4 Maximum value	222
CH1 to CH4 Minimum value	222
CH1 to CH4 Process alarm lower lower limit value	219
CH1 to CH4 Process alarm lower upper limit value	219
CH1 to CH4 Process alarm upper lower limit value	219
CH1 to CH4 Process alarm upper upper limit value	219
CH1 to CH4 Scaling lower limit value	221
CH1 to CH4 Scaling upper limit value	221
CH1 to CH4 Time average/Count average/Moving average	217
Checking by executing a command of the slave station	169
Checking by latest error code (RWr0)	172
Checking by latest warning code (RWr1)	172
Checking the LEDs	182
Connectable modules	49
Connecting an Ethernet cable	61
Conversion speed switch	206
Conversion speed switch function	90

Count average	97
Current input characteristics	232
Cyclic data update watch function	146
Cyclic data update watch time setting	212

D

D LINK LED	21
Details of remote I/O signals	190
Difference conversion function	123
Digital clipping enable/disable setting	220
Digital clipping function	118
Digital operation value	89
Digital output HOLD/CLEAR setting	214
Digital output HOLD/CLEAR setting function	146
DIN rail hook	21,23
DIN rail stopper	58
Disconnecting	62

E

EMC Directive related standards	235
ERR. LED	21
Error clear request flag	199
Error code list	173
Error flag	192
Error flag assignment	210
Error history area (address: 0A00H to 0FFFH)	42
Error history clear command	224
Error history clear completed	225
Error history data 1 to 15	223
Error notification function	143
Ethernet cables	49
Extension connector cover	21
Extension module identification code	222
External dimensions	246
External power supply	239
External power supply monitor request flag	201
External power supply monitor state flag	197
External power supply monitoring function	146
External power supply READY flag	198
External signal assignment function	147

F

Features	16
Functions with an extension module connected	146

G

GAIN LED	21
Gain value	230
General specifications	24

H

How to calculate current consumption	29
How to check error codes and alarm codes	169
How to connect an extension module	54

How to mount modules on a DIN rail 56

I

I LED 21
Initial data setting completed flag 191
Initial data setting request flag 199
Input response time setting 213
Input response time setting function 146
Input signal error detection flag 203
Input signal error detection function 102
Input signal error detection setting 218
Input signal error detection signal 196
Input signal error detection signal assignment 208
Installation and wiring 51
Installation direction 53
Installation environment 52
Installation environment and installation position 52
Installation in a control panel 237
Installation position 52

L

L ER LED 21
Latest error code 202
Latest warning code 202
Laying Ethernet cables 63
LINK LED 21
List of remote buffer memory areas 38
List of remote I/O signals 32
List of remote registers 35

M

Maintenance and inspection 167
Maximum and minimum values 89
Maximum station-to-station distance for an Ethernet cable (maximum cable length) 63
Maximum value/minimum value hold function 101
Maximum value/minimum value reset completed flag 197
Maximum value/minimum value reset request 201
Measures to comply with the EMC Directive 235
MODE LED 21
Mode switch 206
Module control data area (address: 1000H to 14FFH) 43
Module control data area (address: 1200H to 12FFH) 45
Module operation information initialization command 228
Module operation information initialization completed 229
Monitor area (address: 0500H to 09FFH) 41
Monitor area (address: 0700H to 07FFH) 45
Moving average 98

N

Number of ON times integration function 146

O

O/G LED 21
OFFSET LED 21
Offset value 230
Offset/gain setting 84
Others 239

P

P1 21
P2 21
Packing list 14
Parameter area (address: 0000H to 04FFH) 39
Parameter area (address: 0200H to 02FFH) 44
Parameter area initialization command 226
Parameter area initialization completed 227
Parameter settings 70
Part names 20
Performance specifications 25
Precautions for programming 156
Procedures before operation 46
Program example 157
Programming 156
Programming procedure 157
PW LED 21

R

Range setting 215
Range switching function 100
Remote READY 193
Replacing the module 46
Requirements to compliance with the Low Voltage Directive 241
RUN LED 21,23

S

Sampling processing 96
Scaling enable/disable setting 220
Scaling function 109
SET/SEL button 21
Shift function 114
Station number setting 51
Station number setting switch 20
Supported master station 49
Supported software package 49
System configuration 48

T

Terminal block for analog input signals 21,23
Terminal block for external power supply and FG 23
Terminal block for module power supply and FG 21
Terminal cover 21,23
Terms 12
Time average 96
Trigger conversion completed clear request 201
Trigger conversion completed flag 195
Trigger conversion function 128
Trigger conversion request 200
Trigger conversion signal assignment 207

Troubleshooting	169
Troubleshooting by symptom	187

U

Unit test	186
---------------------	-----

V

V LED	21
Voltage input characteristics.	231

W

Warning flag	190
Warning flag assignment	211
Wiring of Ethernet cable.	61
Wiring of terminal block and external devices.	64
Wiring to terminal block for module power supply and FG	59



REVISIONS

*The manual number is given on the bottom left of the back cover.

Print date	*Manual number	Revision
January 2015	SH(NA)-081451ENG-A	First edition
March 2015	SH(NA)-081451ENG-B	■Added or modified parts Section 7.1, 8.2, 9.3, 11.6.1
March 2016	SH(NA)-081451ENG-C	■Added or modified parts SAFETY PRECAUTIONS, Section 2.1, 5.2, 6.5, 7.1, 7.2.1, 7.2.2, 7.3, 8.1, 8.2, 8.16, 11.4, Appendix 9.3
July 2017	SH(NA)-081451ENG-D	■Added or modified parts SAFETY PRECAUTIONS, Section 2.1, 3.7.1, 8.19, 11.1, 11.4, Appendix 3, 10
November 2017	SH(NA)-081451ENG-E	■Added or modified parts SAFETY PRECAUTIONS, Section 2.1, 3.4, 3.5, 3.6, 5.2, 8.11, 11.4, Appendix 3, 8

Japanese manual number: SH-081450-E

This manual confers no industrial property rights or any rights of any other kind, nor does it confer any patent licenses. Mitsubishi Electric Corporation cannot be held responsible for any problems involving industrial property rights which may occur as a result of using the contents noted in this manual.

© 2015 MITSUBISHI ELECTRIC CORPORATION

WARRANTY

Please confirm the following product warranty details before using this product.

1. Gratis Warranty Term and Gratis Warranty Range

If any faults or defects (hereinafter "Failure") found to be the responsibility of Mitsubishi occurs during use of the product within the gratis warranty term, the product shall be repaired at no cost via the sales representative or Mitsubishi Service Company.

However, if repairs are required onsite at domestic or overseas location, expenses to send an engineer will be solely at the customer's discretion. Mitsubishi shall not be held responsible for any re-commissioning, maintenance, or testing on-site that involves replacement of the failed module.

[Gratis Warranty Term]

The gratis warranty term of the product shall be for one year after the date of purchase or delivery to a designated place. Note that after manufacture and shipment from Mitsubishi, the maximum distribution period shall be six (6) months, and the longest gratis warranty term after manufacturing shall be eighteen (18) months. The gratis warranty term of repair parts shall not exceed the gratis warranty term before repairs.

[Gratis Warranty Range]

- (1) The range shall be limited to normal use within the usage state, usage methods and usage environment, etc., which follow the conditions and precautions, etc., given in the instruction manual, user's manual and caution labels on the product.
- (2) Even within the gratis warranty term, repairs shall be charged for in the following cases.
 1. Failure occurring from inappropriate storage or handling, carelessness or negligence by the user. Failure caused by the user's hardware or software design.
 2. Failure caused by unapproved modifications, etc., to the product by the user.
 3. When the Mitsubishi product is assembled into a user's device, Failure that could have been avoided if functions or structures, judged as necessary in the legal safety measures the user's device is subject to or as necessary by industry standards, had been provided.
 4. Failure that could have been avoided if consumable parts (battery, backlight, fuse, etc.) designated in the instruction manual had been correctly serviced or replaced.
 5. Failure caused by external irresistible forces such as fires or abnormal voltages, and Failure caused by force majeure such as earthquakes, lightning, wind and water damage.
 6. Failure caused by reasons unpredictable by scientific technology standards at time of shipment from Mitsubishi.
 7. Any other failure found not to be the responsibility of Mitsubishi or that admitted not to be so by the user.

2. Onerous repair term after discontinuation of production

- (1) Mitsubishi shall accept onerous product repairs for seven (7) years after production of the product is discontinued. Discontinuation of production shall be notified with Mitsubishi Technical Bulletins, etc.
- (2) Product supply (including repair parts) is not available after production is discontinued.

3. Overseas service

Overseas, repairs shall be accepted by Mitsubishi's local overseas FA Center. Note that the repair conditions at each FA Center may differ.

4. Exclusion of loss in opportunity and secondary loss from warranty liability

Regardless of the gratis warranty term, Mitsubishi shall not be liable for compensation to:

- (1) Damages caused by any cause found not to be the responsibility of Mitsubishi.
- (2) Loss in opportunity, lost profits incurred to the user by Failures of Mitsubishi products.
- (3) Special damages and secondary damages whether foreseeable or not, compensation for accidents, and compensation for damages to products other than Mitsubishi products.
- (4) Replacement by the user, maintenance of on-site equipment, start-up test run and other tasks.

5. Changes in product specifications

The specifications given in the catalogs, manuals or technical documents are subject to change without prior notice.

TRADEMARKS

Ethernet is a registered trademark of Fuji Xerox Co., Ltd. in Japan.

The company names, system names and product names mentioned in this manual are either registered trademarks or trademarks of their respective companies.

In some cases, trademark symbols such as [™] or [®] are not specified in this manual.

SH(NA)-081451ENG-E(1711)MEE

MODEL: CCIEF-N-AD-U-E

MODEL CODE: 13JX26

mitsubishi electric corporation

HEAD OFFICE : TOKYO BUILDING, 2-7-3 MARUNOUCHI, CHIYODA-KU, TOKYO 100-8310, JAPAN
NAGOYA WORKS : 1-14, YADA-MINAMI 5-CHOME, HIGASHI-KU, NAGOYA, JAPAN

When exported from Japan, this manual does not require application to the
Ministry of Economy, Trade and Industry for service transaction permission.

Specifications subject to change without notice.