

Smart Laser Sensors E3NC

E72I-E-01

Smart Laser Sensors Ideal for Long Range or Pinpoint Presence/Absence Sensing



- Ideal for applications that cannot be solved with a standard photoelectric sensor and are out of the sensing range of a fiber optic sensor.
- A wide variety of easy-to-use Laser Photoelectric Sensor Heads.
 - Coaxial Retro-reflective Models (E3NC-LH03).
 - Long-distance, variable spot, Diffuse-reflective Models (E3NC-LH02)
 - Small-spot (0.1 mm dia.), Limited-reflective Models (E3NC-LH01).
 - CMOS Reflective Models (E3NC-SH series).
- Smart Tuning to achieve stable detection with easy setup.
- White on black display characters for high visibility.
- Robot cables for reliable operation in harsh environments.



For the most recent information on models that have been certified for safety standards, refer to your OMRON website.

 Refer to the *Safety Precautions* on page 14.

Features

Retro-reflective Models: E3NC-LH03

- Maximum sensing distance of 8 m.
- Stable detection of many types of workpieces.
- Stable detection of highly transparent films.

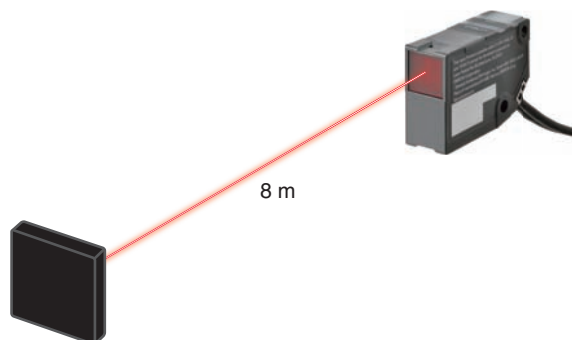

Diffuse-reflective Models: E3NC-LH02 **PAT.P**

- Long-distance detection at up to 1.2 m.
- Spot can be adjusted to the workpiece or application.

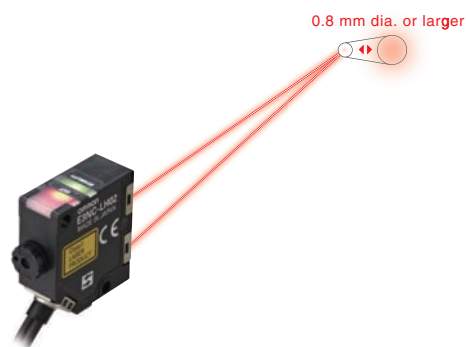

CMOS Laser, Reflective Models: E3NC-SH250H/SH250/SH100

- Stable detection even for varying workpiece colors and materials.
- Stable detection for inclined Head installation and varying workpiece shapes.

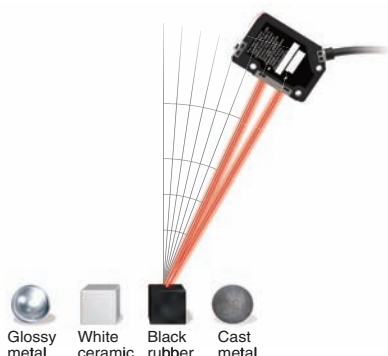







Amplifier Units

- Same shape as Fiber Amplifier Units plus easy operation.
- Smart Tuning with one button.



Ordering Information





Sensor Heads: E3NC-L Compact Laser Sensor Series (Dimensions → page 17)

Sensing method	Appearance	Beam shape	Sensing distance	Laser class	Cable length	Model
Coaxial Retro-reflective with MSR function		Spot	 8 m *	Class 1	2 m	E3NC-LH03 2M
					5 m	E3NC-LH03 5M
Diffuse-reflective		Variable spot	 1.2 m		2 m	E3NC-LH02 2M
					5 m	E3NC-LH02 5M
Limited-reflective		Spot	 70±15 mm		2 m	E3NC-LH01 2M
					5 m	E3NC-LH01 5M

* These values apply when an E39-R21, E39-R22, E39-RS10, or E39-RS11 Reflector is used. A Reflector is not included. Purchase a Reflector separately to match the intended use of the Sensor.

Note: Only an E3NC-LA□□ Amplifier Unit can be connected.



Amplifier Units: E3NC-L Compact Laser Sensor Series (Dimensions → page 19)

Connecting method	Appearance	Inputs/outputs	Model	
			NPN output	PNP output
Pre-wired (2 m)		2 outputs + 1 input	E3NC-LA21 2M	E3NC-LA51 2M
Wire-saving Connector		1 output + 1 input	E3NC-LA7	E3NC-LA9
M8 Connector		1 output + 1 input	E3NC-LA24	E3NC-LA54
Connector for Sensor Communications Unit *		---	E3NC-LA0	

* A Sensor Communications Unit is required if you want to use the Amplifier Unit on a network.





Note: Only an E3NC-LH□□ Sensor Head can be connected.

Sensor Heads: E3NC-S Ultra-compact CMOS Laser Sensor Series (Dimensions → page 18)

Sensing method	Appearance	Beam shape	Measurement range	Laser class	Cable length	Model
Distance-settable		Spot	 35 to 250 mm	Class 2	2 m	E3NC-SH250H 2M
				Class 1	2 m	E3NC-SH250 2M
					2 m	E3NC-SH100 2M

Note: Only an E3NC-SA□□ Amplifier Unit can be connected.

Amplifier Units: E3NC-S Ultra-compact CMOS Laser Sensor Series (Dimensions → page 19)

Connecting method	Appearance	Inputs/outputs	Model	
			NPN output	PNP output
Pre-wired (2 m)		2 outputs + 1 input	E3NC-SA21 2M	E3NC-SA51 2M
Wire-saving Connector		1 output + 1 input	E3NC-SA7	E3NC-SA9
M8 Connector		1 output + 1 input	E3NC-SA24	E3NC-SA54
Connector for Sensor Communications Unit *		---	E3NC-SA0	

* A Sensor Communications Unit is required if you want to use the Amplifier Unit on a network.

Note: Only an E3NC-SH□□ or E3NC-SH□□H Sensor Head can be connected.

Accessories (Sold Separately)

Sensor Head Accessories

Reflectors for Retro-reflective Sensors (Dimensions → page 21)

A Reflector is not provided with the Sensor Head. It must be ordered separately as required.

Applicable Sensor Head	Appearance	Model	Quantity
E3NC-LH03		E39-R21	1
		E39-R22	
		E39-RS10	
		E39-RS11	

Lens Attachments for Sensor Heads (Dimensions → page 21)





A Lens Attachment is not provided with the Sensor Head. It must be ordered separately as required.

Applicable Sensor Head	Appearance	Model	Quantity
E3NC-LH03		E39-P51	1
E3NC-LH02		E39-P52	

Note: You can combine the Lens Attachment with an applicable Sensor Head to create a line beam.

Sensor Head Mounting Brackets (Dimensions → page 22)



A Mounting Bracket is not provided with the Sensor Head. It must be ordered separately as required.

Applicable Sensor Head	Appearance	Model	Quantity	Contents
E3NC-LH03		E39-L190	1	Mounting Bracket: 1 Nut plate: 1 Phillips screws (M3x18): 2
E3NC-LH02		E39-L185		
E3NC-LH01		E39-L186		
E3NC-SH250H E3NC-SH250 E3NC-SH100		E39-L187		
		E39-L188		

Amplifier Unit Accessories



Wire-saving Connectors (Required for models for Wire-saving Connectors.) (Dimensions → page 26)

Connectors are not provided with the Amplifier Unit and must be ordered separately. *Protective stickers are provided.

Type	Appearance	Cable length	No. of conductors	Model
Master Connector		2 m	4	E3X-CN21
Slave Connector			2	E3X-CN22

Sensor I/O Connectors (Required for models for M8 Connectors.) (Dimensions → page 26)

Connectors are not provided with the Amplifier Unit and must be ordered separately.

Size	Cable	Appearance	Cable type	Model	
M8	Standard cable	Straight 	2 m	4-wire	XS3F-M8PVC4S2M
			5 m		XS3F-M8PVC4S5M
		L-shaped 	2 m		XS3F-M8PVC4A2M
			5 m		XS3F-M8PVC4A5M

Note: For details, refer to XS3 which can be accessed from your OMRON website.

Amplifier Unit Mounting Bracket (Dimensions → page 27)

A Mounting Bracket is not provided with the Amplifier Unit. It must be ordered separately as required.

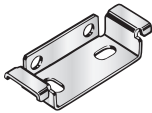
Appearance	Model	Quantity
	E39-L143	1

Note: For details, refer to Mounting Brackets on E39-L/E39-S/E39-R which can be accessed from your OMRON website.

DIN Track (Dimensions → page 27)

A DIN Track is not provided with the Amplifier Unit. It must be ordered separately as required.

Appearance	Type	Model	Quantity
	Shallow type, total length: 1 m	PFP-100N	1
	Shallow type, total length: 0.5m	PFP-50N	
	Deep type, total length: 1 m	PFP-100N2	





End Plate (Dimensions → page 27)

Two End Plates are provided with the Sensor Communications Unit. End Plates are not provided with the Amplifier Unit. They must be ordered separately as required.

Appearance	Model	Quantity
	PFP-M	1

Related Products

Sensor Communications Units

Type	Appearance	Model
Sensor Communications Unit for EtherCAT		E3NW-ECT
Sensor Communications Unit for CompoNet		E3NW-CRT
Sensor Communications Unit for CC-Link		E3NW-CCL
Distributed Sensor Unit *		E3NW-DS

Refer to your OMRON website for details.

* The Distributed Sensor Unit can be connected to any of the Sensor Communications Units.

EtherCAT® is a registered trademark and patented technology, licensed by Beckhoff Automation GmbH, Germany.

CompoNet is a registered trademark of the ODVA.
CC-Link is a registered trademark of Mitsubishi Electric Corporation. The trademark is managed by the CC-Link Partner Association.

Ratings and Specifications

Compact Laser Sensors: E3NC-L

Sensor Heads

Sensing method		Coaxial Retro-reflective with MSR function		Diffuse-reflective		Limited-reflective
		E3NC-LH03	E3NC-LH03+ E39-P51	E3NC-LH02	E3NC-LH02+ E39-P52	E3NC-LH01
Light source (wavelength)*1		Visible semiconductor laser diode (660 nm), 1.35 mW (average output: 315 μW) (JIS Class 1, IEC/EN Class 1, and FDA Class 1)				
Sensing distance*2	Giga-power mode (GIGA)	8 m	0.5 m	1,200 mm	1,000 mm	70±15 mm
	Standard mode (Std)	6 m		750 mm	600 mm	
	High-speed mode (HS)	3.5 m		250 mm	200 mm	
	Super-high-speed mode (SHS)	2 m		200 mm	150 mm	
Beam shape		Spot	Line	Spot	Line	Spot
Beam size*3		Approx. 2 mm dia. at 1 m	Line length: Approx. 25 mm at 250 mm Line length: Approx. 50 mm at 500 mm	Approx. 0.8 mm dia. at 300 mm	Line length: Approx. 45 mm at 500 mm Line length: Approx. 100 mm at 1,000 mm	Approx. 0.1 mm dia. at 70 mm
Differential distance*4		---		10% of sensing distance max.		
Indicators		OUT indicator (orange) and STABILITY indicator (green)				
Ambient illumination (Receiver side)		Incandescent lamp: 10,000 lx max., Sunlight: 20,000 lx max.				
Ambient temperature range		Operating: -10 to 55°C; Storage: -25 to 70°C (with no icing or condensation)				
Ambient humidity range		Operating and storage: 35% to 85% (with no condensation)				
Altitude		2,000 m max.				
Installation environment		Pollution degree 3 (as per IEC 60947-1)				
Insulation resistance		20 MΩ min. (at 500 VDC)				
Dielectric strength		1,000 VAC at 50/60 Hz for 1 min				
Vibration resistance (destruction)		10 to 55 Hz with a 1.5-mm double amplitude or 100 m/s ² for 2 hours each in X, Y, and Z directions				
Shock resistance (destruction)		500 m/s ² for 3 times each in X, Y, and Z directions				
Degree of protection		IEC IP67*5		IEC IP65 (E3NC-LH02: Applies only when adjuster is locked.)*5		
Connecting method		Pre-wired connector (standard length: 2 m)				
Materials	Sensor Head	Case	Polybutylene terephthalate (PBT)			
		Lens	Methacrylic resin (PMMA)			
		Cable	Vinyl chloride (PVC)			
	Lens Attachment	Case	---	ABS	---	ABS
Lens		---	Methacrylic resin (PMMA)	---	Methacrylic resin (PMMA)	---
Weight (packed state/Sensor Head only)	Models with 2-m cable	Approx. 120 g/approx. 70 g		Approx. 115 g/approx. 65 g		
	Models with 5-m cable	Approx. 180 g/approx. 130 g		Approx. 175 g/approx. 125 g		
	Lens Attachment	---	Approx. 25 g/ approx. 2 g	---	Approx. 25 g/ approx. 2 g	---
Accessories		Instruction Manual				

*1. These Sensors excluding the E3NC-LH03 are classified as Class 1 laser devices under IEC 60825-1 and the regulations of Laser Notice No. 50 for FDA certification. CDRH (Center for Devices and Radiological Health) registration has been completed. (Accession Number: 1220690)
Application to the CDRH (Center for Devices and Radiological Health) is scheduled for the E3NC-LH03.

*2. The values were measured using the OMRON standard sensing object (white paper) for the E3NC-LH01, E3NC-LH02, and E3NC-LH02 + E39-P52.
The values for the E3NC-LH03, and E3NC-LH03 + E39-P51 apply when an E39-R21, E39-R22, E39-RS10, or E39-RS11 Reflector is used. Other Reflectors are not recommended.

*3. Defined at the 1/e² (13.5%) of the central intensity at the measurement distance.
Measurement may be influenced if there is light leakage outside the defined region and the surroundings of the target object have a high reflectance in comparison to the target object.

*4. Measured at the rated sensing distance.

*5. The E39-P5□ contains a packing to prevent entry of foreign matter. The degree of protection between the E3NC-LH□□ and E39-P5□ is not specified.

Amplifier Units

Item	Type	Standard models			Model for Sensor Communications Unit	
		NPN output	E3NC-LA21	E3NC-LA7	E3NC-LA24	E3NC-LA0
		PNP output	E3NC-LA51	E3NC-LA9	E3NC-LA54	
Connecting method	Pre-wired	Wire-saving Connector	M8 Connector	Connector for Sensor Communications Unit		
Inputs/outputs	Outputs	2 outputs		1 output	---*1	
	External inputs	1 input				
Power supply voltage *2		10 to 30 VDC, including 10% ripple (p-p)			Supplied from the connector through the Sensor Communications Unit	
Power consumption *3		At Power Supply Voltage of 24 VDC Normal mode: 1,560mW max. (Current consumption: 65mA max.) Eco ON: 1,320 mW max. (Current consumption: 55 mA max.) Eco LO: 1,440 mW max. (Current consumption: 60 mA max.)				
Control outputs *4		Load power supply voltage: 30 VDC max., open-collector output Load current: Groups of 1 to 3 Amplifier Units: 100 mA max., Groups of 4 to 30 Amplifier Units: 20 mA max. (Residual voltage: At load current of less than 10 mA: 1 V max. At load current of 10 to 100 mA: 2 V max.) OFF current: 0.1 mA max.			--	
External inputs		Refer to *5.			--	
Indicators		7-segment displays (Sub digital display: green, Main digital display: white) Display direction: Switchable between normal and reversed. OUT indicator (orange), L/D indicator (orange), ST indicator (blue), DPC indicator (green), and OUT selection indicator (orange, only on models with 2 outputs)				
Protection circuits		Power supply reverse polarity protection, output short-circuit protection, and output reverse polarity protection			Power supply reverse polarity protection and output short-circuit protection	
Response time	Super-high-speed mode (SHS)*6	Operate or reset: 80 μs				
	High-speed mode (HS)	Operate or reset: 250 μs				
	Standard mode (Stdnd)	Operate or reset: 1 ms				
	Giga-power mode (GIGA)	Operate or reset: 16 ms				
Sensitivity adjustment		Smart Tuning (2-point tuning, full auto tuning, position tuning, maximum sensitivity tuning, power tuning, or percentage tuning (-99% to +99%)), or manual adjustment.				
Maximum connectable Units		30			With E3NW-ECT: 30 units *7 With E3NW-CRT: 16 units With E3NW-CCL: 16 units	
No. of Units for mutual interference prevention	Super-high-speed mode (SHS)*6	0				
	High-speed mode (HS)	2				
	Standard mode (Stdnd)	2				
	Giga-power mode (GIGA)	4				
Functions	Dynamic power control (DPC)	Provided				
	Timer	Select from timer disabled, OFF-delay, ON-delay, one-shot, or ON-delay + OFF-delay timer: 1 to 9,999 ms				
	Zero reset	Negative values can be displayed. (Threshold value is shifted.)				
	Resetting settings*8	Select from initial reset (factory defaults) or user reset (saved settings).				
	Eco mode*9	Select from OFF (digital display lit), ECO ON (digital display not lit), and ECO LO (digital display dimmed).				
	Bank switching	Select from banks 1 to 4.				
	Power tuning	Select from ON or OFF.				
	Output 1	Select from Normal Detection Mode or Area Detection Mode.				
	Output 2	Select from normal detection mode, alarm output mode, or error output mode.	---		Select from normal detection mode, alarm output mode, or error output mode.	
	External input	Select from input OFF, tuning, power tuning, laser OFF, zero reset, or bank switching.			--	
Hysteresis width	Select from standard setting or user setting.					

*1. Two sensor outputs are allocated in the programmable logic controller PLC I/O table.

PLC operation via Communications Unit enables reading detected values and changing settings.

*2. Applicable Sensor Head is the series of E3NC-LH□□ (Input/Output 10-30V DC Class 2)

*3. At Power Supply Voltage of 10 to 30 VDC.

Normal mode: 1,650 mW max. (Current consumption: 55 mA max. at 30 VDC, 115 mA max. at 10 VDC)

Eco ON: 1,410 mW max. (Current consumption: 47 mA max. at 30 VDC, 95 mA max. at 10 VDC)

Eco LO: 1,530 mW max. (Current consumption: 51 mA max. at 30 VDC, 105 mA max. at 10 VDC)

*4. The total for both outputs of a model with 2 outputs is 100 mA max. (Residual voltage: Load current of less than 10 mA: 1 V max., Load current of 10 to 100 mA: 2 V max.)

*5. The following details apply to the input.

	Contact input (relay or switch)	Non-contact input (transistor)	Input time*5-1
NPN	ON: Shorted to 0 V (Sourcing current: 1 mA max.) OFF: Open or shorted to Vcc.	ON: 1.5 V max. (Sourcing current: 1 mA max.) OFF: Vcc - 1.5 V to Vcc (Leakage current: 0.1 mA max.)	ON: 9 ms min. OFF: 20 ms min.
PNP	ON: Shorted to Vcc (Sinking current: 3 mA max.) OFF: Open or shorted to 0 V.	ON: Vcc - 1.5 V to Vcc (Sinking current: 3 mA max.) OFF: 1.5 V max. (Leakage current: 0.1 mA max.)	

*5-1. Input time is 25 ms (ON)/(OFF) only when (in tUnE) or (in PtUn) input is selected.

*6. The mutual interference prevention function is disabled if the detection mode is set to super-high-speed mode.

*7. When connected to an OMRON NJ-series Controller.

*8. The bank is not reset by the user reset function or saved by the user save function.

*9. Eco LO is supported for Amplifier Units manufactured in July 2014 or later.

Item	Type	Standard models			Model for Sensor Communications Unit
	NPN output	E3NC-LA21	E3NC-LA7	E3NC-LA24	E3NC-LA0
	PNP output	E3NC-LA51	E3NC-LA9	E3NC-LA54	
Connecting method	Pre-wired	Wire-saving Connector	M8 Connector	Connector for Sensor Communications Unit	
Ambient temperature range*	Operating: Groups of 1 or 2 Amplifier Units: -25 to 55°C, Groups of 3 to 10 Amplifier Units: -25 to 50°C, Groups of 11 to 16 Amplifier Units: -25 to 45°C, Groups of 17 to 30 Amplifier Units: -25 to 40°C Storage: -30 to 70°C (with no icing or condensation)			Operating: Groups of 1 or 2 Amplifier Units: 0 to 55°C, Groups of 3 to 10 Amplifier Units: 0 to 50°C, Groups of 11 to 16 Amplifier Units: 0 to 45°C, Groups of 17 to 30 Amplifier Units: 0 to 40°C, Storage: -30 to 70°C (with no icing or condensation)	
Ambient humidity range	Operating and storage: 35% to 85% (with no condensation)				
Altitude	2,000 m max.				
Installation environment	Pollution degree 3 (as per IEC 60947-1)				
Insulation resistance	20 MΩ (at 500 VDC)				
Dielectric strength	1,000 VAC at 50/60 Hz for 1 min				
Vibration resistance (destruction)	10 to 55 Hz with a 1.5-mm double amplitude for 2 hours each in X, Y, and Z directions				
Shock resistance (destruction)	500 m/s ² for 3 times each in X, Y, and Z directions			150m/s ² for 3 times each in X, Y, and Z directions	
Weight (packed state/Amplifier Unit only)	Approx. 115 g/approx. 75 g	Approx. 60 g/approx. 20 g	Approx. 65 g/approx. 25 g		
Materials	Case	Polycarbonate (PC)			
	Cover	Polycarbonate (PC)			
	Cable	Vinyl chloride (PVC)			
Accessories	Instruction Manual				

* When the number of connected units is 11 or more, the ambient temperature is less than 50°C.

Accessories

Reflectors

Item	Model	E39-R21	E39-R22	E39-RS10	E39-RS11
Ambient temperature	Operating: -10 to 55°C; Storage: -25 to 70°C (with no icing or condensation)				
Ambient humidity	Operating/storage: 35% to 85% (with no condensation)				
Vibration resistance (destruction)	10 to 55 Hz with a 1.5-mm double amplitude or 100 m/s ² for 2 hours each in X, Y, and Z directions				
Shock resistance (destruction)	500 m/s ² 3 times each in X, Y, and Z directions				
Degree of protection	IEC IP67 (E39-R21 and E39-R22 only)				
Materials	Reflective surface: Methacrylic resin (PMMA) Back surface: Polybutylene terephthalate (PBT)			Methacrylic resin (PMMA)	
Weight (packed state/Reflector only)	Approx. 30 g/approx. 5 g	Approx. 35 g/approx. 10 g	Approx. 26 g/approx. 1 g	Approx. 30 g/approx. 5 g	
Accessories	Instruction manual				

Ultra-compact CMOS Laser Sensor: E3NC-S

Sensor Heads

Sensing method		Distance-settable		
Item	Model	E3NC-SH250H	E3NC-SH250	E3NC-SH100
Light source (wavelength)*1		Visible semiconductor laser diode (660 nm), 1 mW (average output: 220 μ W) (JIS Class 2, IEC/EN Class 2, and FDA Class 2)	Visible semiconductor laser diode (660 nm), 0.5 mW (average output: 100 μ W) (JIS Class 1, IEC/EN Class 1, and FDA Class 1)	
Measurement range		35 to 250 mm (display value: 350 to 2,500)		35 to 100 mm (display value: 350 to 1,000)
Standard detected level difference*2		35 to 180mm: 9 mm 180 to 250 mm: 25 mm		35 to 50 mm: 1.5 mm 50 to 100 mm: 3 mm
Beam size*3		Approx. 1 mm dia. at 250 mm		Approx. 0.5 mm dia. at 100 mm
Indicators		OUT indicator (orange), STABILITY indicator (green), and ST indicator (blue)		
Ambient illumination (Receiver side)		Incandescent lamp: 4,000 lx max., Sunlight: 8,000 lx max.	Incandescent lamp: 2,000 lx max., Sunlight: 4,000 lx max.	Incandescent lamp: 4,000 lx max., Sunlight: 8,000 lx max.
Ambient temperature range		Operating: -10 to 50°C; Storage: -25 to 70°C (with no icing or condensation)		
Ambient humidity range		Operating and storage: 35% to 85% (with no condensation)		
Altitude		2,000 m max.		
Installation environment		Pollution degree 3 (as per IEC 60947-1)		
Insulation resistance		20 M Ω min. (at 500 VDC)		
Dielectric strength		1,000 VAC at 50/60 Hz for 1 min		
Vibration resistance (destruction)		10 to 55 Hz with a 1.5-mm double amplitude for 2 hours each in X, Y, and Z directions		
Shock resistance (destruction)		500 m/s ² 3 times each in X, Y, and Z directions		
Degree of protection		IEC IP67		
Connecting method		Pre-wired connector (Standard cable length: 2 m)		
Materials	Case	Polybutylene terephthalate (PBT)		
	Lens	Methacrylic resin (PMMA)		
	Cable	Vinyl chloride (PVC)		
Weight (packed state/Sensor Head only)		Approx. 125 g/approx. 75 g		
Accessories		Instruction Manual, laser warning label (E3NC-SH250H only)		

Note: Incorrect detection may occur outside the measurement range if the object has a high reflection factor.

*1. These Sensors are classified as Class 1 laser devices under IEC 60825-1 and the regulations of Laser Notice No. 50 for FDA certification. CDRH (Center for Devices and Radiological Health) registration has been completed. (Accession Number: 1220691)

*2. The values were measured at the center of the sensing distance using OMRON's standard sensing object (white ceramic).

*3. Beam size: Defined at the 1/e² (13.5 %) of the central intensity at the measurement center distance.

Measurement may be influenced if there is light leakage outside the defined region and the surroundings of the target object have a high reflectance in comparison to the target object.

Also, when detecting a workpiece that is smaller than the beam size, a correct value may not be obtained.

Amplifier Units

Item	Type	Standard models			Model for Sensor Communications Unit	
		NPN output	E3NC-SA21	E3NC-SA7	E3NC-SA24	E3NC-SA0
		PNP output	E3NC-SA51	E3NC-SA9	E3NC-SA54	
Connecting method	Pre-wired	Wire-saving Connector	M8 Connector	Connector for Sensor Communications Unit		
Inputs/ outputs	Outputs	2 outputs	1 output		-- *1	
	External inputs	1 input				
Power supply voltage *2		10 to 30 VDC, including 10% ripple (p-p)			Supplied from the connector through the Sensor Communications Unit	
Power consumption *3		At Power Supply Voltage of 24 VDC Normal mode: 1,920 mW max. (Current consumption: 80 mA max.) Eco ON: 1,680 mW max. (Current consumption: 70 mA max.) Eco LO: 1,800 mW max. (Current consumption: 75 mA max.)				
Control outputs *4		Load power supply voltage: 30 VDC max., open-collector output Load current: Groups of 1 to 3 Amplifier Units: 100 mA max., Groups of 4 to 30 Amplifier Units: 20 mA max. (Residual voltage: At load current of less than 10 mA: 1 V max. At load current of 10 to 100 mA: 2 V max.) OFF current: 0.1 mA max.			--	
External inputs		Refer to *5.				
Indicators		7-segment displays (Sub digital display: green, Main digital display: white) Display direction: Switchable between normal and reversed. OUT indicator (orange), L/D indicator (orange), ST indicator (blue), ZERO indicator (green), and OUT selection indicator (orange, only on models with 2 outputs)				
Protection circuits		Power supply reverse polarity protection, output short-circuit protection, and output reverse polarity protection			Power supply reverse polarity protection and output short-circuit protection	
Response time	Super-high-speed mode (SHS) *6	Operate or reset: 1.5 ms				
	High-speed mode (HS)	Operate or reset: 5 ms				
	Standard mode (Std)	Operate or reset: 10 ms				
	Giga-power mode (GIGA)	Operate or reset: 50 ms				
Sensitivity adjustment		Smart Tuning (2-point tuning, full auto tuning, 1-point tuning, tuning without workpiece, 2-point area tuning, 1-point area tuning, or area tuning without workpiece), or manual adjustment				
Maximum connectable Units		30			With E3NW-ECT: 30 units *7 With E3NW-CRT: 16 units With E3NW-CCL: 16 units	
No. of Units for mutual interference prevention	Super-high-speed mode (SHS) *6	0				
	High-speed mode (HS)	2				
	Standard mode (Std)	2				
	Giga-power mode (GIGA)	2				
Functions	Timer	Select from timer disabled, OFF-delay, ON-delay, one-shot, or ON-delay + OFF-delay timer: 1 to 9,999 ms				
	Zero reset	Negative values can be displayed. (Threshold value is shifted.)				
	Resetting settings *8	Select from initial reset (factory defaults) or user reset (saved settings).				
	Eco mode *9	Select from OFF (digital display lit), ECO ON (digital display not lit), and ECO LO (digital display dimmed).				
	Bank switching	Select from banks 1 to 4.				
	Output 1	Select from Normal detection mode, Area detection mode, or hold mode.				
	Output 2	Select from Normal detection mode or Error output mode.	--		Select from Normal detection mode or Error output mode.	
	External input	Select from input OFF, tuning, laser OFF, zero reset, or bank switching.			--	
	Keep function *10	Select from ON or OFF.				
	Background suppression *11	Select from ON or OFF.				
Hysteresis width		Select from standard setting or user setting.				

*1. Two sensor outputs are allocated in the programmable logic controller PLC I/O table.

PLC operation via Communications Unit enables reading detected values and changing settings.

*2. Applicable Sensor Head is the series of E3NC-SH□□ (Input/Output 10-30V DC Class 2).

*3. At Power Supply Voltage of 10 to 30 VDC.

Normal mode: 2,250 mW max. (Current consumption: 75 mA max. at 30 VDC, 145 mA max. at 10 VDC)

Eco ON: 2,010 mW max. (Current consumption: 67 mA max. at 30 VDC, 125 mA max. at 10 VDC)

Eco LO: 2,130 mW max. (Current consumption: 71 mA max. at 30 VDC, 135 mA max. at 10 VDC)

*4. The total for both outputs of a model with 2 outputs is 100 mA max. (Residual voltage: Load current of less than 10 mA: 1 V max., Load current of 10 to 100 mA: 2 V max.).

*5. The following details apply to the input.

	Contact input (relay or switch)	Non-contact input (transistor)	Input time*5-1
NPN	ON: Shorted to 0 V (Sourcing current: 1 mA max.) OFF: Open or shorted to Vcc.	ON: 1.5 V max. (Sourcing current: 1 mA max.) OFF: Vcc - 1.5 V to Vcc (Leakage current: 0.1 mA max.)	ON: 9 ms min. OFF: 20 ms min.
PNP	ON: Shorted to Vcc (Sinking current: 3 mA max.) OFF: Open or shorted to 0 V.	ON: Vcc - 1.5 V to Vcc (Sinking current: 3 mA max.) OFF: 1.5 V max. (Leakage current: 0.1 mA max.)	

*5-1. Input time is 25 ms (ON)/(OFF) only when (in tUnE) input is selected.

*6. The mutual interference prevention function is disabled if the detection mode is set to super-high-speed mode.

*7. When connected to an OMRON NJ-series Controller.

*8. The bank is not reset by the user reset function or saved by the user save function.

*9. Eco LO is supported for Amplifier Units manufactured in August 2014 or later.

*10. The output for a measurement error is set. ON: The value of the output from before the measurement error is retained. OFF: The output is turned OFF when a measurement error occurs.

*11. Only the sensing object is detected when tuning.

Item	Type	Standard models			Model for Sensor Communications Unit
	NPN output	E3NC-SA21	E3NC-SA7	E3NC-SA24	E3NC-SA0
	PNP output	E3NC-SA51	E3NC-SA9	E3NC-SA54	
Connecting method	Pre-wired	Wire-saving Connector	M8 Connector	Connector for Sensor Communications Unit	
Ambient temperature range*	Operating: Groups of 1 or 2 Amplifier Units: -25 to 55°C, Groups of 3 to 10 Amplifier Units: -25 to 50°C, Groups of 11 to 16 Amplifier Units: -25 to 45°C, Groups of 17 to 30 Amplifier Units: -25 to 40°C Storage: -30 to 70°C (with no icing or condensation)				Operating: Groups of 1 or 2 Amplifier Units: 0 to 55°C, Groups of 3 to 10 Amplifier Units: 0 to 50°C, Groups of 11 to 16 Amplifier Units: 0 to 45°C, Groups of 17 to 30 Amplifier Units: 0 to 40°C Storage: -30 to 70°C (with no icing or condensation)
Ambient humidity range	Operating and storage: 35% to 85% (with no condensation)				
Insulation resistance	20 MΩ (at 500 VDC)				
Altitude	2,000 m max.				
Installation environment	Pollution degree 3 (as per IEC 60947-1)				
Dielectric strength	1,000 VAC at 50/60 Hz for 1 min				
Vibration resistance (destruction)	10 to 55 Hz with a 1.5-mm double amplitude for 2 hours each in X, Y, and Z directions				
Shock resistance (destruction)	500 m/s ² for 3 times each in X, Y, and Z directions				150 m/s ² for 3 times each in X, Y, and Z directions
Weight (packed state/Amplifier Unit only)	Approx. 115 g/approx. 75 g	Approx. 60 g/approx. 20 g	Approx. 65 g/approx. 25 g		
Materials	Case	Polycarbonate (PC)			
	Cover	Polycarbonate (PC)			
	Cable	Vinyl chloride (PVC)			
Accessories	Instruction Manual				

* When the number of connected units is 11 or more, the ambient temperature is less than 50°C.

Engineering Data (Reference Value)

Beam Diameter Vs. Distance

**Retro-reflective Model
E3NC-LH03**

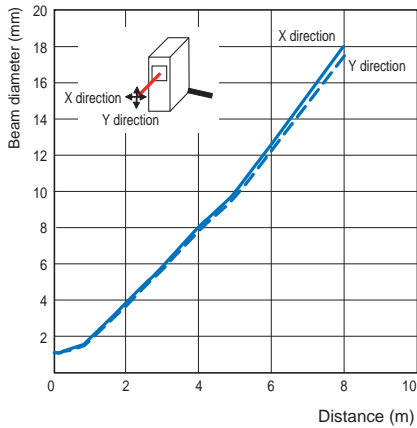

**Retro-reflective Model
E3NC-LH03 + E39-P51**

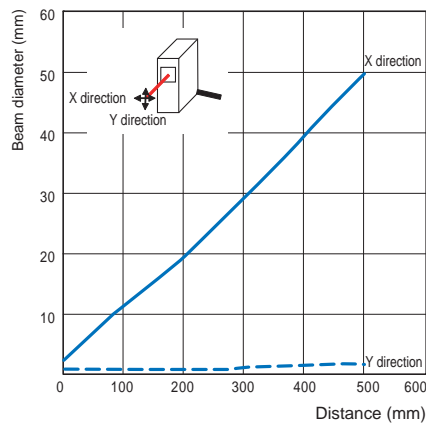

**Diffuse-reflective Model
E3NC-LH02**

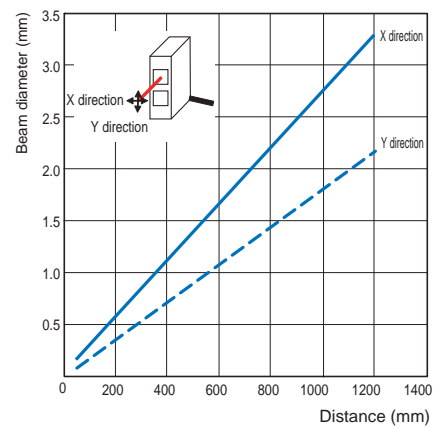

**Diffuse-reflective Model
E3NC-LH02 + E39-P52**

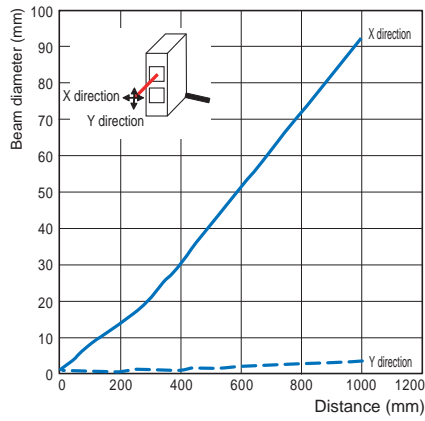

**Limited-reflective Model
E3NC-LH01**

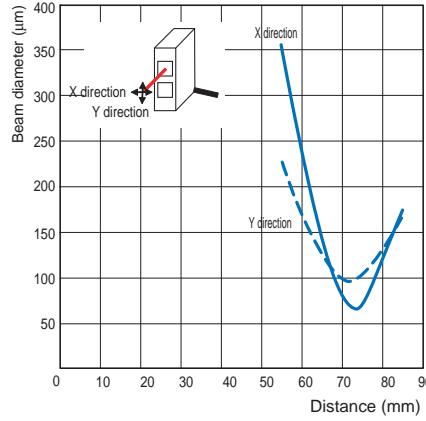

**Distance-settable Model
E3NC-SH250/SH250H**

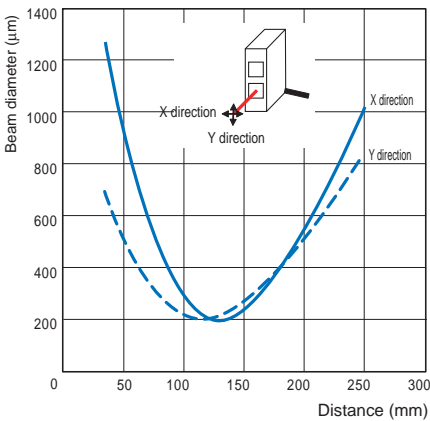

**Distance-settable Model
E3NC-SH100**

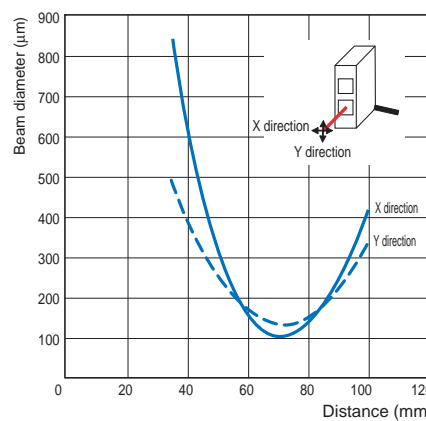

I/O Circuit Diagrams

NPN Output

Model	Operation mode	Timing chart	L/D indicator	Output circuit
E3NC-LA21 E3NC-SA21	Light-ON	ch1/ Incident light ch2 No incident light OUT indicator Lit (orange) Not lit Output ON transistor OFF Load Operate (e.g., relay) Reset (Between brown and black (orange) leads)	L lit.	
	Dark-ON	ch1/ Incident light ch2 No incident light OUT indicator Lit (orange) Not lit Output ON transistor OFF Load Operate (e.g., relay) Reset (Between brown and black (orange) leads)	D lit.	
E3NC-LA7 E3NC-LA24 E3NC-SA7 E3NC-SA24	Light-ON	Incident light No incident light OUT indicator Lit (orange) Not lit Output ON transistor OFF Load Operate (e.g., relay) Reset (Between brown and black leads)	L lit.	
	Dark-ON	Incident light No incident light OUT indicator Lit (orange) Not lit Output ON transistor OFF Load Operate (e.g., relay) Reset (Between brown and black leads)	D lit.	

PNP Output

Model	Operation mode	Timing chart	L/D indicator	Output circuit
E3NC-LA51 E3NC-SA51	Light-ON	ch1/ Incident light ch2 No incident light OUT indicator Lit (orange) Not lit Output ON transistor OFF Load Operate (e.g., relay) Reset (Between blue and black (orange) leads)	L lit.	
	Dark-ON	ch1/ Incident light ch2 No incident light OUT indicator Lit (orange) Not lit Output ON transistor OFF Load Operate (e.g., relay) Reset (Between blue and black (orange) leads)	D lit.	
E3NC-LA9 E3NC-LA54 E3NC-SA9 E3NC-SA54	Light-ON	Incident light No incident light OUT indicator Lit (orange) Not lit Output ON transistor OFF Load Operate (e.g., relay) Reset (Between blue and black leads)	L lit.	
	Dark-ON	Incident light No incident light OUT indicator Lit (orange) Not lit Output ON transistor OFF Load Operate (e.g., relay) Reset (Between blue and black leads)	D lit.	

Nomenclature

Compact Laser Sensors

E3NC-LA21/LA51/LA0

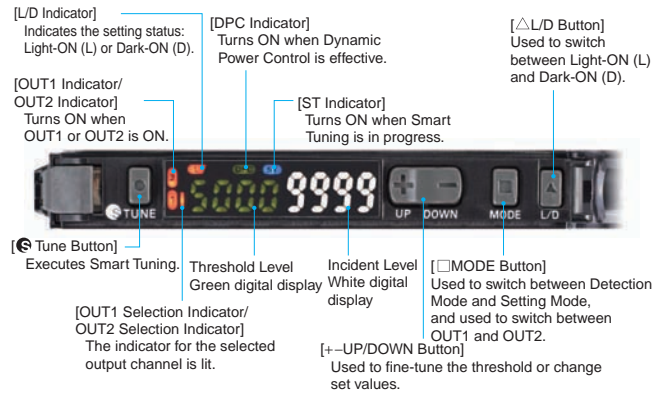

E3NC-LA7/LA9/LA24/LA54

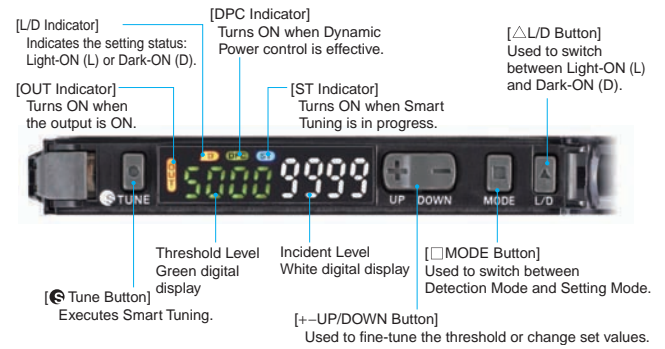

Ultra-compact CMOS Laser Sensors

E3NC-SA21/SA51/SA0

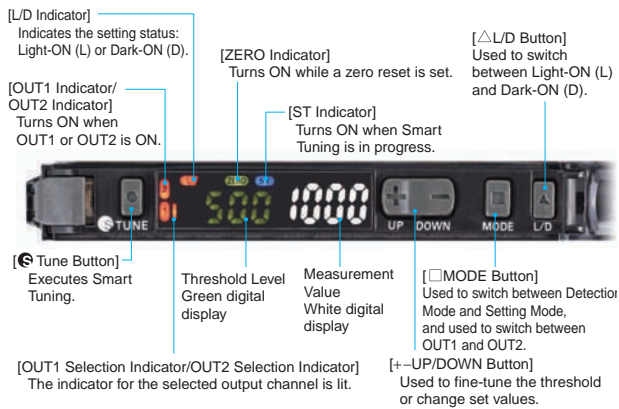

E3NC-SA7/SA9/SA24/SA54

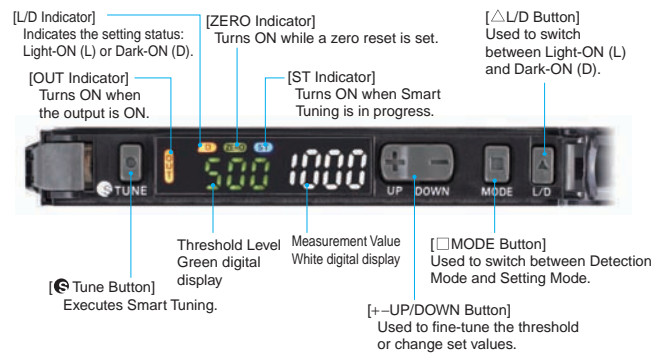

Safety Precautions

To ensure safe operation, be sure to read and follow the Instruction Manual provided with the Sensor.

Indication and Meaning for Safe Use

 WARNING	Indicates a potentially hazardous situation which, if not avoided, will result in minor or moderate injury, or may result in serious injury or death. Additionally there may be significant property damage.
Precautions for Safe Use	Supplementary comments on what to do or avoid doing, to use the product safely.
Precautions for Correct Use	Supplementary comments on what to do or avoid doing, to prevent failure to operate, malfunction or undesirable effect on product performance.

Sensor Heads

Laser Safety

Various safety standards regarding laser devices are stipulated in Japan and abroad. When this Sensor Head is used in Japan and when it is assembled in Japan but exported to a foreign country, the safety standards are classified into three cases.

1. When Using the Sensor Head in Japan

JIS C6802 stipulates the safety measures that must be observed by the user for each type of laser equipment.

E3NC-LH□□ Sensor Heads: Class 1

E3NC-SH□□ Sensor Heads: Class 1

E3NC-SH□□H Sensor Heads: Class 2

WARNING

Do not expose your eyes to the laser beam either directly or indirectly (i.e., after reflection from a mirror or shiny surface). The laser beam has a high power density and exposure may result in loss of sight.



Attention

Use of controls or adjustments or performance of procedures other than those specified herein may result in hazardous radiation exposure.

Do not disassemble the Sensor Head. Doing so may cause the laser beam to leak, resulting in a risk of visual impairment.



- The following laser warning label and laser description labels are attached to the sides of the Sensor Heads.

E3NC-LH03

Description Label



Certification Label



E3NC-LH01 /E3NC-LH02

Description Label



Certification Label



E3NC-SH□□

Description Label



Certification Label



E3NC-SH□□H

Laser Warning Label



Certification Label



2. Using in the USA

When using devices in which the Sensor Head is installed in the USA, the devices are subject to FDA (Food and Drug Administration) laser regulations of the USA.

E3NC-LH03:

These Sensor Heads are classified as Class 1 laser devices under IEC/EN 60825-1 and the regulations of Laser Notice No. 50 for this certification. Application to the CDRH (Center for Devices and Radiological Health) is scheduled.

E3NC-LH01, E3NC-LH02:

These Sensor Heads are classified as Class 1 laser devices under IEC/EN 60825-1 and the regulations of Laser Notice No. 50 for this certification. CDRH (Center for Devices and Radiological Health) registration has been completed. (Accession Number: 1220690)

E3NC-SH□□, E3NC-SH□□H:

These Sensor Heads are classified as Class 1 or Class 2 laser devices under IEC/EN 60825-1 and the regulations of Laser Notice No. 50 for this certification. CDRH (Center for Devices and Radiological Health) registration has been completed. (Accession Number: 1220691)

- For countries other than Japan

Replace the warning label with the corresponding English label (supplied with SH□□H).



3. Using in Europe

E3NC-LH□□, E3NC-SH□□:

These Sensor Heads are classified in Class 1 under EN 60825-1.

E3NC-SH□□H:

These Sensor Heads are classified in Class 2 under EN 60825-1.

Precautions for Safe Use

The following precautions must be observed to ensure safe operation of the Sensor Head.

- 1. Installation Environment**
 - Do not use the Sensor Head in an environment where explosive or flammable gas is present.
 - To secure the safety of operation and maintenance, do not install the Sensor Head close to high-voltage devices or power devices.
- 2. Power Supply and Wiring**
 - Always use an E3NC-LA□□, E3NC-LA0, E3NC-SA□□ or E3NC-SA0 Amplifier Unit. If a different Amplifier Unit is used, damage or fire may occur.
 - If you short the cable, reconnect it as specified. If the connections are not correct, damage or fire may occur.
 - High-voltage lines and power lines must be wired separately from the Sensor Head. Wiring them together or placing them in the same duct may cause induction, resulting in malfunction or damage.
 - Always turn OFF the power supply before connecting or disconnecting the connectors.
- 3. Installation**
 - Use screws for installation and tighten the screws securely, but do not exceed the specified tightening torque.
Specified torque (M3): 0.5 N·m
- 4. Others**
 - Never disassemble (including removing labels), repair, modify, deform by pressure, or incinerate the Sensor Head. Do not turn the adjuster on the E3NC-LH02 with a force that is greater than 40 mN·m. Damage or fire may occur.
 - Dispose of the Sensor Head as industrial waste.
 - If you notice any abnormalities, immediately stop using the Sensor Head, turn OFF the power supply, and contact your OMRON representative.
- 5. Conditions of UL**
(Applicable Models: E3NC-LH01/LH02 Only)
 - The E3NC-LH series sensor head accessories shall be used with the E3NC-LA amplifiers.
These amplifiers and sensor head accessories shall be installed within a suitable enclosure where all components, including cords and connectors, shall be entirely contained within the same enclosure.
(Applicable Models: E3NC-SH100/SH250 Only)
 - The E3NC-SH series sensor head accessories shall be used with the E3NC-SA amplifiers.
These amplifiers and sensor head accessories shall be installed within a suitable enclosure where all components, including cords and connectors, shall be entirely contained within the same enclosure.
- 6. Shortening the connection cable for use**
(Applicable Models: E3NC-LH01/LH02/SH100/SH250 Only)
 - The shortened cable has not been evaluated by UL.)

Precautions for Correct Use

Observe the following precautions to prevent failure to operate, malfunctions, or undesirable effects on Sensor Head performance.

- 1. Installation Environment**
Do not install the Sensor Head in locations subject to the following conditions:
 - Ambient temperatures outside of the rated range
 - Condensation caused by rapid changes in temperature
 - Relative humidity that is not between 35% and 85%
 - Corrosive or flammable gas
 - Dust, salt, or iron particles
 - Direct vibration or shock
 - Strong external light interference (such as other laser beams or electric arc-welding machines)
 - Direct sunlight or near heaters
 - Water, oil, or chemical fumes or spray
 - Strong magnetic or electric fields

- 2. Warming Up**
 - The circuits will be unstable just after the power supply is turned ON, so measurement values may fluctuate gradually.
 - For accurate measurements, allow the product to stand for at least 10 minutes after turning ON the power supply before use. (E3NC-S Series)
- 3. Maintenance and Inspection**
 - Always turn OFF the power supply before adjusting or connecting/disconnecting the Sensor Head.
 - Do not use thinner, benzene, acetone, or kerosene to clean the Sensor Head.
 - If large dust particles or dirt adheres to the filter on the front of the Sensor Head, use a blower brush (such as one used to clean camera lenses) to blow it off. Do not blow the dust particles or dirt with your mouth. To remove dust particles or dirt, wipe it off gently with a soft cloth (such as one for cleaning lenses) moistened with a small amount of alcohol. Do not wipe it off with excessive force. Scratches on the filter may cause errors.
- 4. Sensing Object**
 - The Sensor Head cannot accurately measure objects with the following materials and shapes: Transparent objects (with the E3NC-LH03, objects that are extremely transparent), objects with an extremely low reflection ratio, objects smaller than the spot diameter, objects with a large curvature, excessively inclined objects, etc. Also, for long-distance detection, the Sensor may falsely operate if a white object approaches near the Sensor Head (E3NC-LH03).
- 5. Do not use the Sensor in water, rainfall, or outdoors.**
- 6. A ferrite core is attached to the Sensor Head end of the cable connected to the E3NC-LH03 5M. Do not remove the ferrite core or change its position. Also, do not bend the cable within 12 mm of each end of the ferrite core. Doing so may damage the cable.**

Attaching a Lens Attachment (E39-P51 or E39-P52)

- Check the widths of the slots in the Sensor and the widths of the tabs on the Lens Attachment and attach the Lens Attachment as shown below. (The Lens Attachment must be in the correct orientation, so the widths of the tabs on the Lens Attachment are different on the top and bottom.)

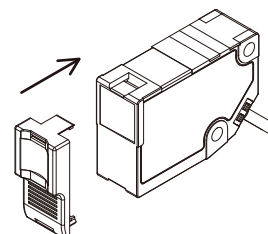

- After you attach the Lens Attachment, make sure that the tabs are completely engaged in the slots in the Sensor.

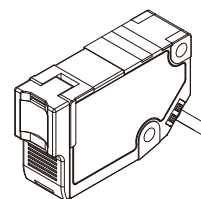

Amplifier Units

WARNING

This Amplifier Unit is not designed or rated for ensuring safety of persons either directly or indirectly.

Do not use it for such purposes.



Do not use the Amplifier Unit with voltage in excess of the rated voltage.

Excess voltage may result in malfunction or fire.



Never use the Amplifier Unit with an AC power supply.

Otherwise, explosion may result.



Precautions for Safe Use

The following precautions must be observed to ensure safe operation of the Amplifier Unit. Doing so may cause damage or fire.

- Do not install the Amplifier Unit in the following locations.
 - Locations subject to direct sunlight
 - Locations subject to condensation due to high humidity
 - Locations subject to corrosive gas
 - Locations subject to vibration or mechanical shocks exceeding the rated values
 - Locations subject to exposure to water, oil, chemicals
 - Locations subject to steam
 - Locations subjected to strong magnetic field or electric field
- Do not use the Amplifier Unit in environments subject to flammable or explosive gases.
- Do not use the Amplifier Unit in any atmosphere or environment that exceeds the ratings.
- To secure the safety of operation and maintenance, do not install the Amplifier Unit close to high-voltage devices or power devices.
- High-voltage lines and power lines must be wired separately from the Amplifier Unit. Wiring them together or placing them in the same duct may cause induction, resulting in malfunction or damage.
- Do not apply any load exceeding the ratings. Otherwise, damage or fire may result.
- Do not short the load. Otherwise, damage or fire may result.
- Connect the load correctly.
- Do not miswire such as the polarity of the power supply.
- Do not use the Amplifier Unit if the case is damaged.
- Burn injury may occur. The Amplifier Unit surface temperature rises depending on application conditions, such as the ambient temperature and the power supply voltage. Attention must be paid during operation or cleaning.
- When setting the sensor, be sure to check safety such as by stopping the equipment.
- Be sure to turn off the power supply before connecting or disconnecting wires.
- Do not attempt to disassemble, repair, or modify the Amplifier Unit in any way.
- When disposing of the Amplifier Unit, treat it as industrial waste.
- Do not use the Sensor in water, rainfall, or outdoors.
- UL Standard Certification (Applicable Models: E3NC-LA21/LA51/SA21/SA51 Only)

Only the sensors with Enhanced UL Certification Mark are certified by UL. They are intended to be supplied by a "Class 2 circuit". When used in United States and Canada, Please use the same Class 2 source for input and output. The overcurrent protection current rating is 2A max. They were evaluated as Open type and shall be installed within a enclosure.

Precautions for Correct Use

- Be sure to mount the unit to the DIN track until it clicks.
- When using the Amplifier Units with Wire-saving Connectors, attach the protective stickers (provided with E3X-CN-series Connectors) on the unused power pins to prevent electrical shock and short circuiting.

When using the Amplifier Units with Connectors for Communications Units, attach the protective caps (provided with E3NW-series Sensor Communications Unit).

Amplifier Unit with Wire-saving Connector

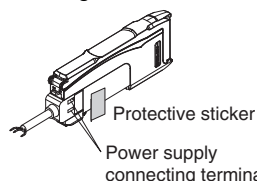

Amplifier Unit with Connector for Sensor Communications Unit

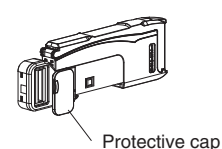

- Use an extension cable with a minimum thickness of 0.3 mm² and less than 10 m long.
- Do not apply the forces on the cord exceeding the following limits: Pull: 40 N; torque: 0.1 N·m; pressure: 20 N; bending: 29.4 N
- Do not apply excessive force (9.8 N max.) such as tension, compression or torsion to the connector of the Sensor Head that is fixed to the Amplifier Unit.
- Always keep the protective cover in place when using the Amplifier Unit. Not doing so may cause malfunction.
- It may take time until the received light intensity and measured value become stable immediately after the power is turned on depending on use environment.
- The product is ready to operate 200 ms after the power supply is turned ON.
- The Mobile Console E3X-MC11, E3X-MC11-SV2 and E3X-MC11-S cannot be connected.
- The mutual interference prevention function does not work when in combination with E3C/E2C/E3X.
- If the unit receives excessive sensor light, the mutual interference prevention function may not work properly, resulting in malfunction of the unit. In such case, increase the threshold.
- Standard models (E3NC-□A21/51/7/9)

The Sensor Communications Unit E3X-DRT21-S, E3X-CRT, E3X-ECT and E3NW cannot be connected.

Model for Sensor Communications Unit (E3NC-□A0)

The Sensor Communications Unit E3NW can be connected. E3X-DRT21-S, E3X-CRT, E3X-ECT cannot be connected.
- If you notice an abnormal condition such as a strange odor, extreme heating of the unit, or smoke immediately stop using the product, turn off the power, and consult your dealer.
- Do not use thinner, benzene, acetone, and lamp oil for cleaning.

Dimensions

Sensor Heads

Retro-reflective Model E3NC-LH03

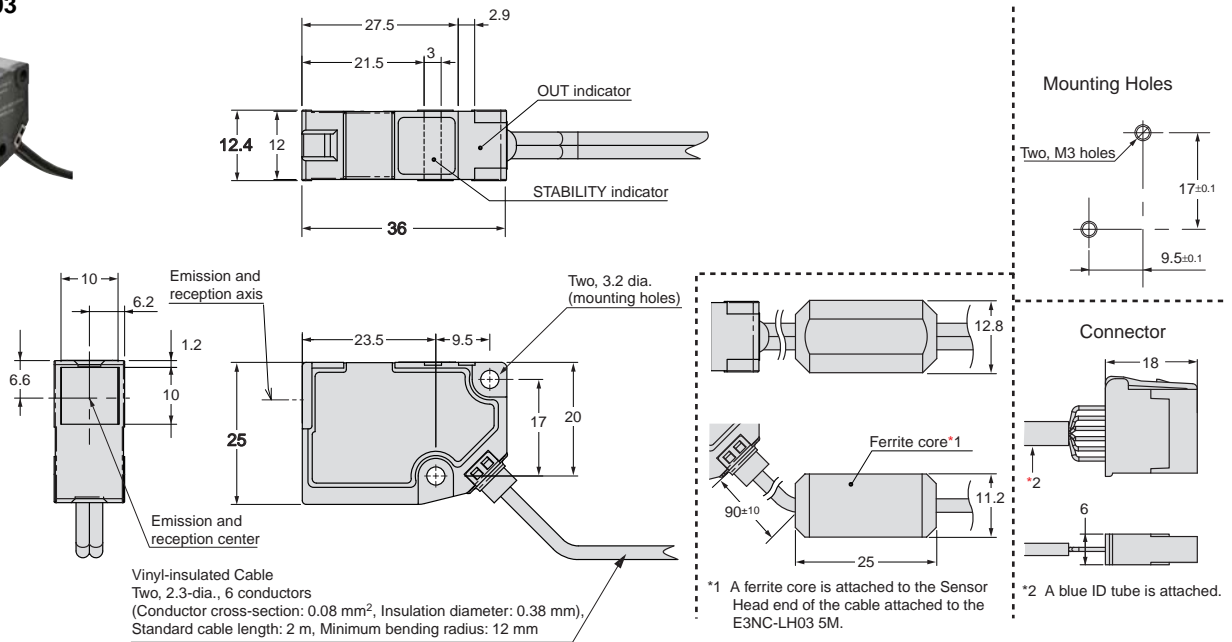

Diffuse-reflective Model E3NC-LH02

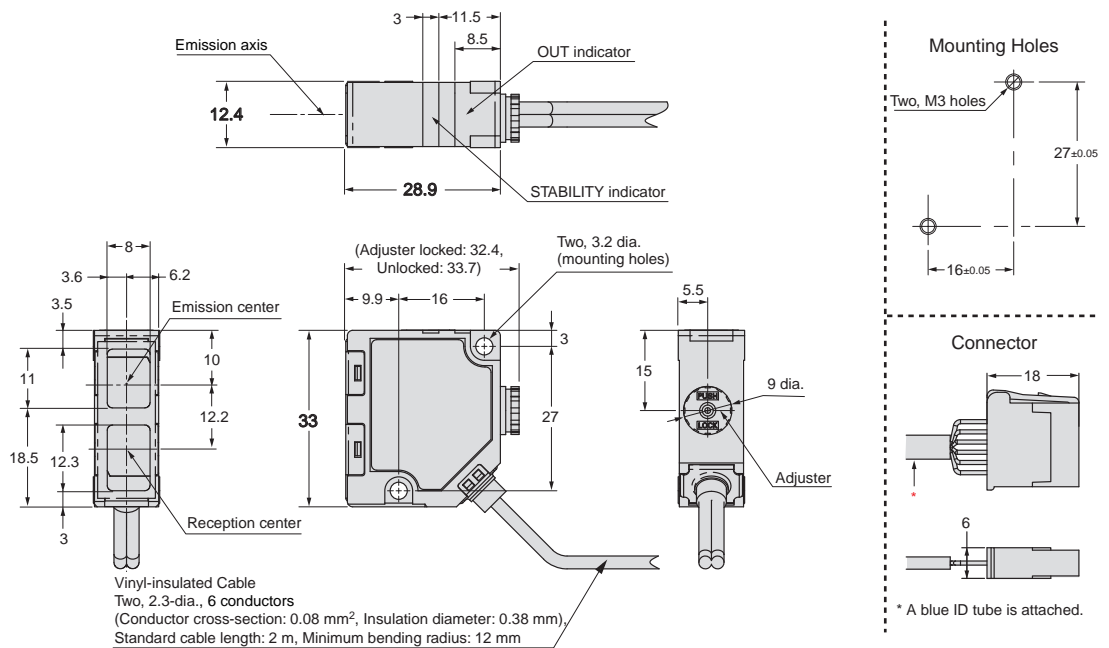

Limited-reflective Model
E3NC-LH01

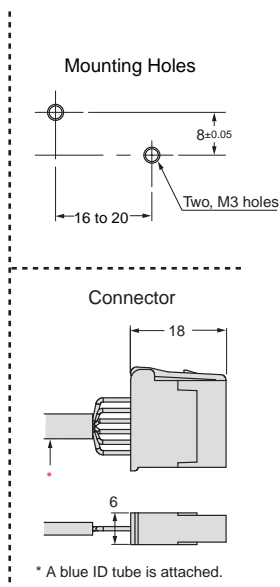
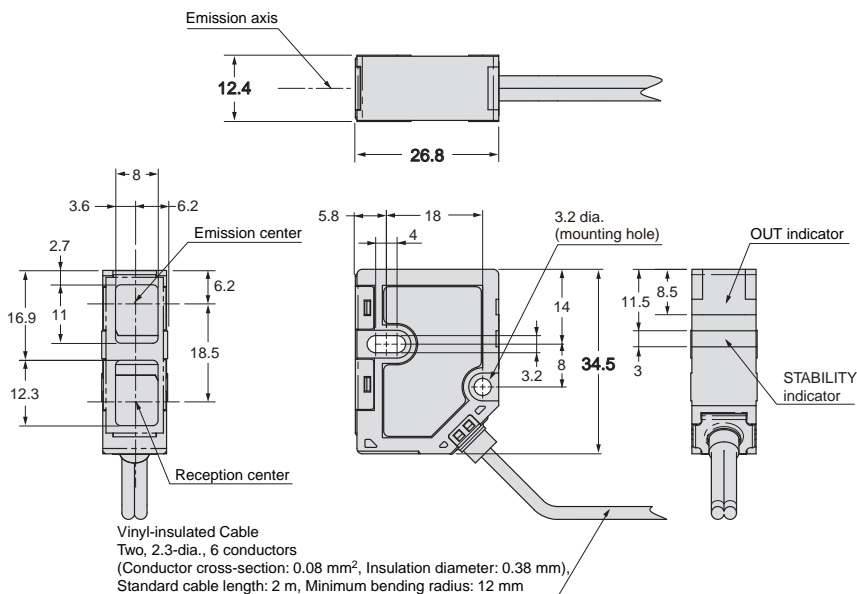

Distance-settable Models
E3NC-SH250H
E3NC-SH250
E3NC-SH100



*1 E3NC-SH100
L = 35 to 100 mm,
A = 15.92° to 5.67°

E3NC-SH250H/250
L = 35 to 250 mm,
A = 15.92° to 2.27°

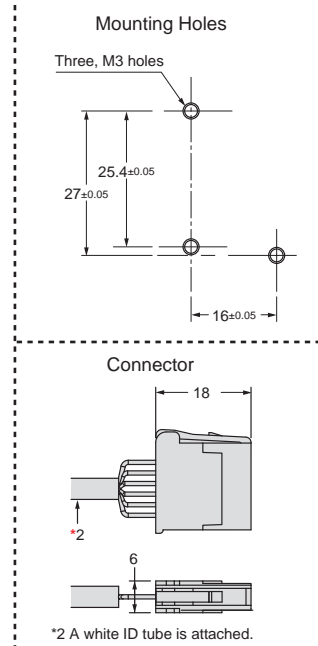
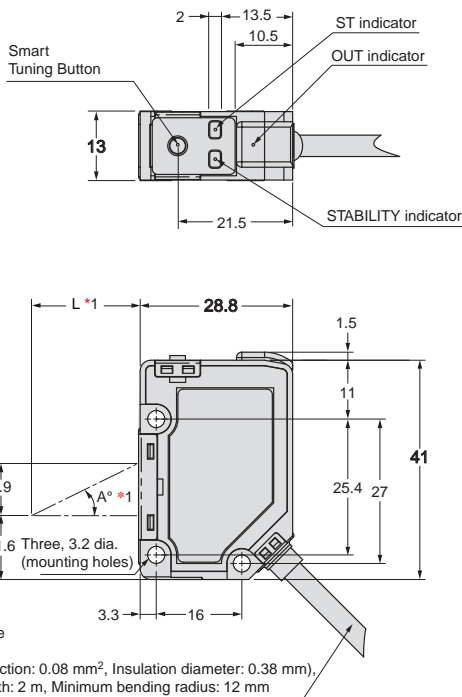

Amplifier Units

Pre-wired Amplifier Units

- E3NC-LA21
- E3NC-LA51
- E3NC-SA21
- E3NC-SA51

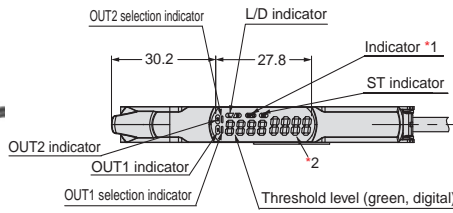

*1. The indicators are as follows:

E3NC-LA21	DPC indicator
E3NC-LA51	DPC indicator
E3NC-SA21	ZERO indicator
E3NC-SA51	ZERO indicator

*2. The display is as follows:

E3NC-LA21	Incident level (white, digital)
E3NC-LA51	Incident level (white, digital)
E3NC-SA21	Measurement value (white, digital)
E3NC-SA51	Measurement value (white, digital)

*3. Cable Specifications

Round vinyl-insulated cable, 4 dia., 5 conductors
 (Conductor cross-section: 0.2 mm², Insulation diameter: 0.9 mm),
 Standard cable length: 2 m, Minimum bending radius: 12 mm

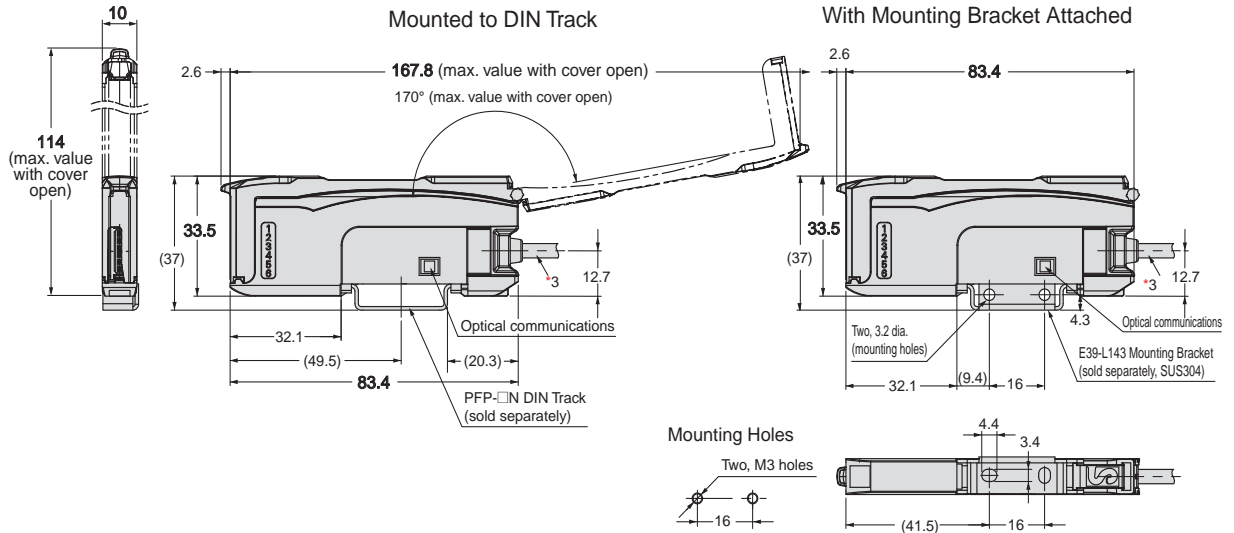

Amplifier Units with Wire-saving Connectors

- E3NC-LA7
- E3NC-LA9
- E3NC-SA7
- E3NC-SA9

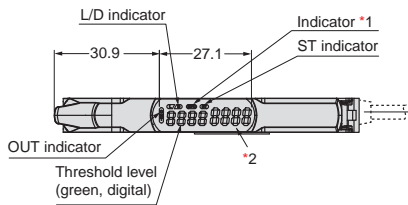

*1. The indicators are as follows:

E3NC-LA7	DPC indicator
E3NC-LA9	DPC indicator
E3NC-SA7	ZERO indicator
E3NC-SA9	ZERO indicator

*2. The display is as follows:

E3NC-LA7	Incident level (white, digital)
E3NC-LA9	Incident level (white, digital)
E3NC-SA7	Measurement value (white, digital)
E3NC-SA9	Measurement value (white, digital)

*3. Cable Specifications

Model	Outer diameter	No. of conductors
E3X-CN22	4.0	2
E3X-CN21		4

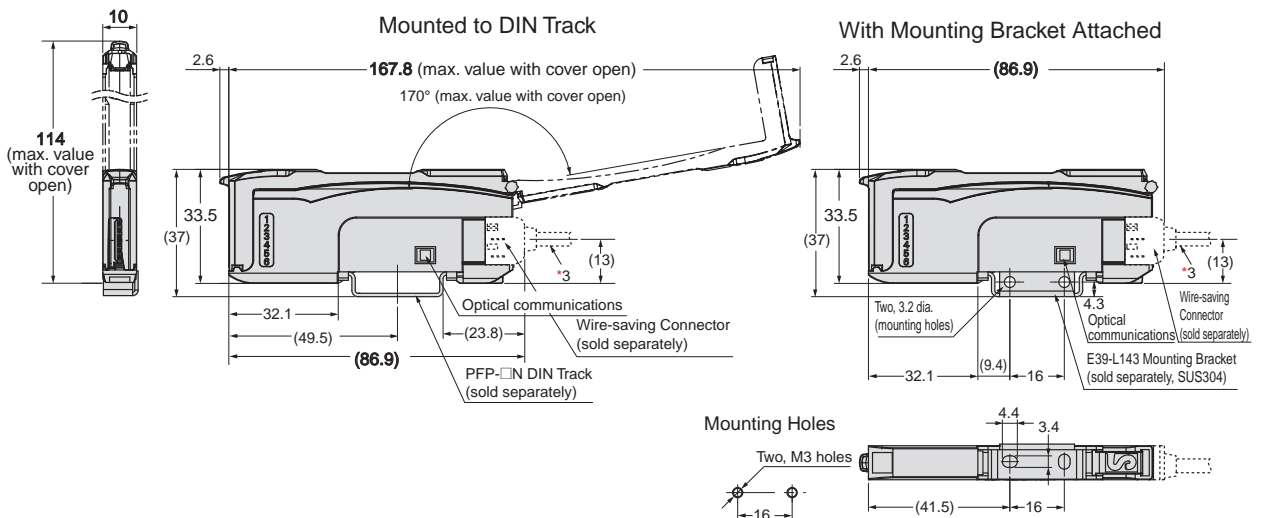

Amplifier Units with M8 Connectors

E3NC-LA24
E3NC-LA54
E3NC-SA24
E3NC-SA54

*1. The indicators are as follows:

E3NC-LA24	DPC indicator
E3NC-LA54	indicator
E3NC-SA24	ZERO indicator
E3NC-SA54	indicator

*2. The display is as follows:

E3NC-LA24	Incident level (white, digital)
E3NC-LA54	
E3NC-SA24	Measurement value (white, digital)
E3NC-SA54	

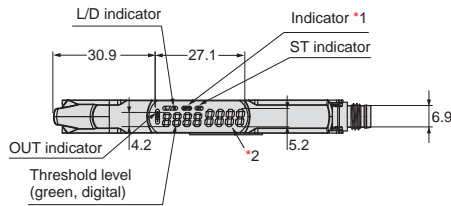

Connector pin arrangement

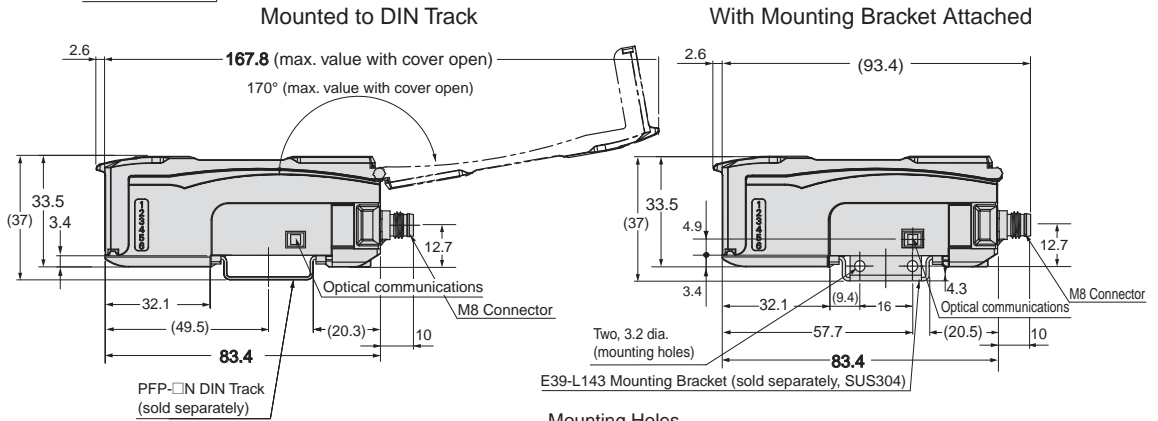
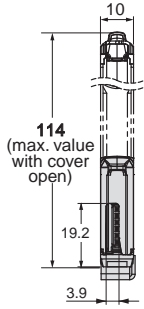
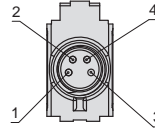

Mounting Holes

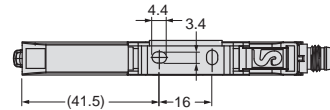
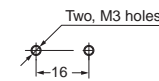

Amplifier Units with Connectors for Sensor Communications Unit

E3NC-LA0
E3NC-SA0

*1. The indicators are as follows:

E3NC-LA0	DPC indicator
E3NC-SA0	ZERO indicator

*2. The display is as follows:

E3NC-LA0	Incident level (white, digital)
E3NC-SA0	Measurement value (white, digital)

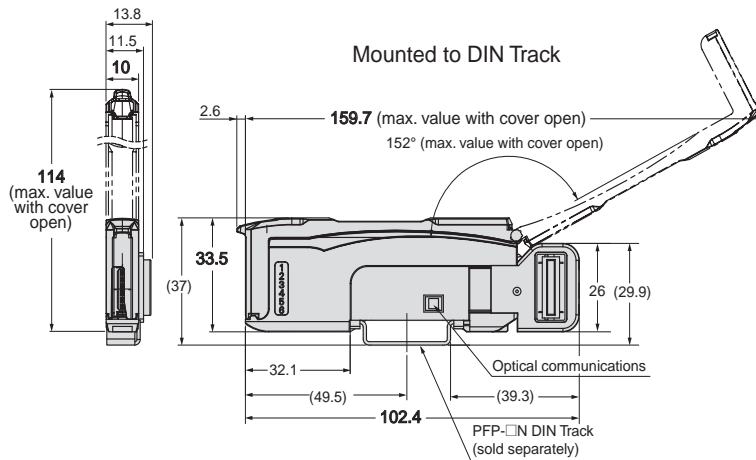
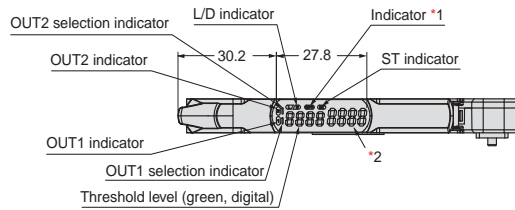

Accessories (Sold Separately)

Reflectors for Retro-reflective Sensors

E39-R21

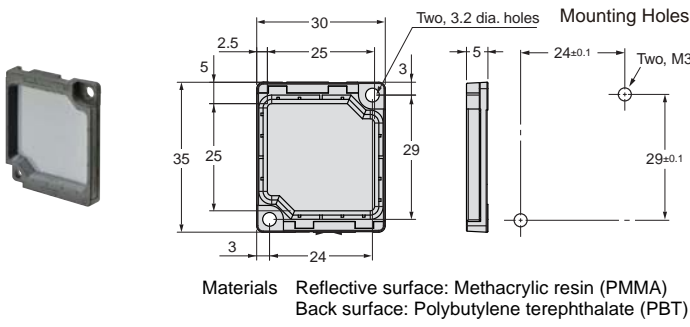

E39-RS10

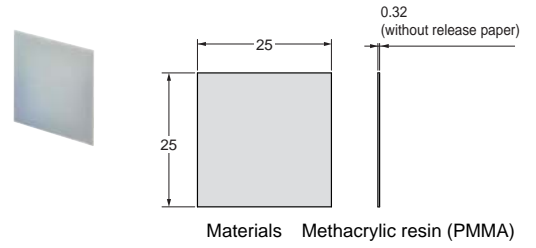

E39-R22

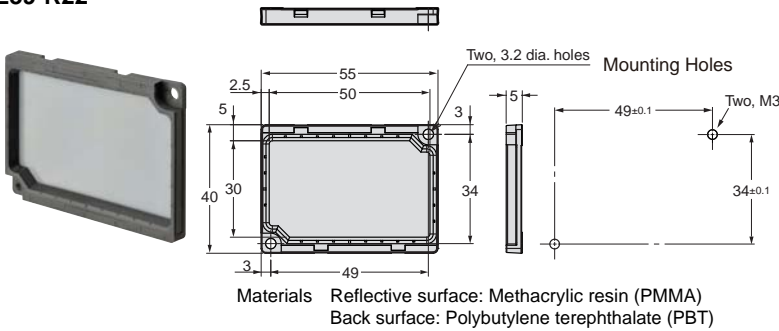

E39-RS11

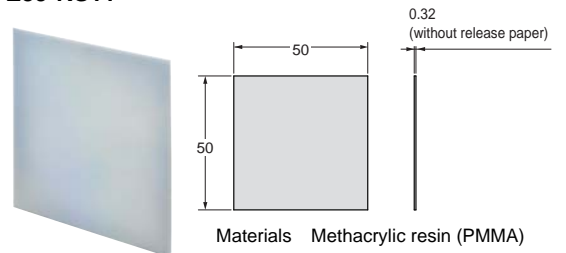

Lens Attachment

E39-P51

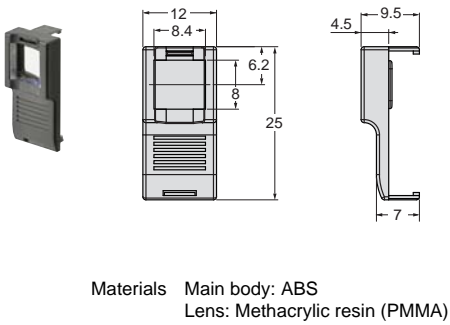

With E39-P51 Lens Attachment Attached

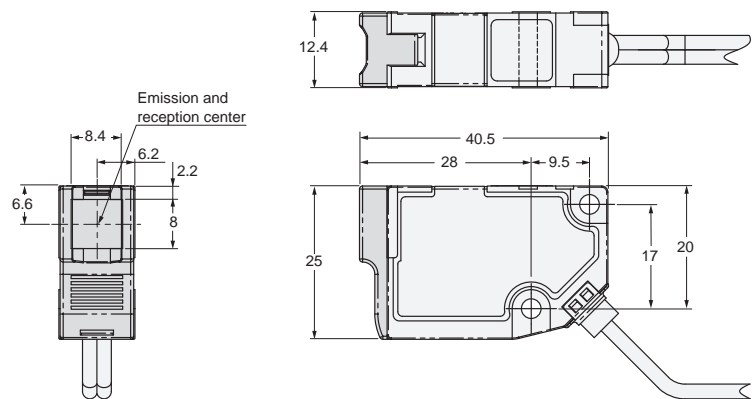

E39-P52

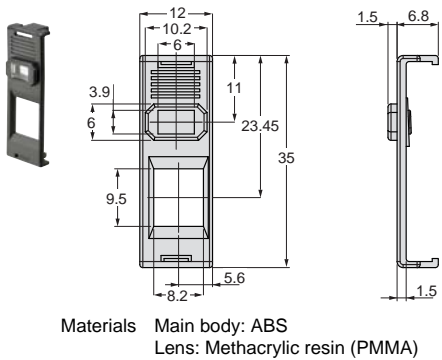

With E39-P52 Lens Attachment Attached

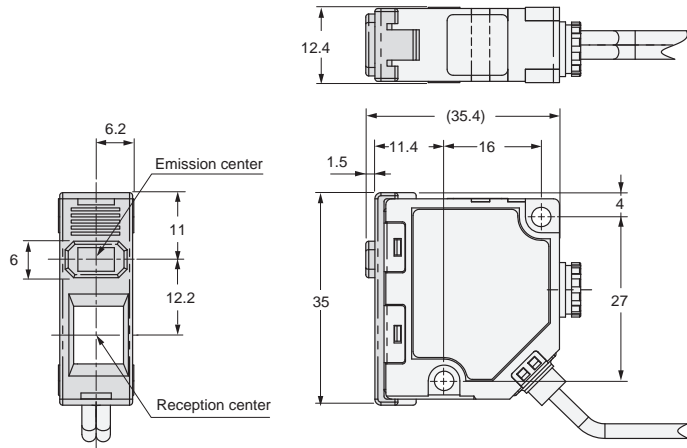

Sensor Head Mounting Brackets
E39-L190

Mounting Bracket
 Materials: Stainless steel (SUS304)
 Thickness: 1.2 mm
 Accessories: Phillips screws (M3x18, P = 0.5, stainless steel): 2, Nut plate: 1

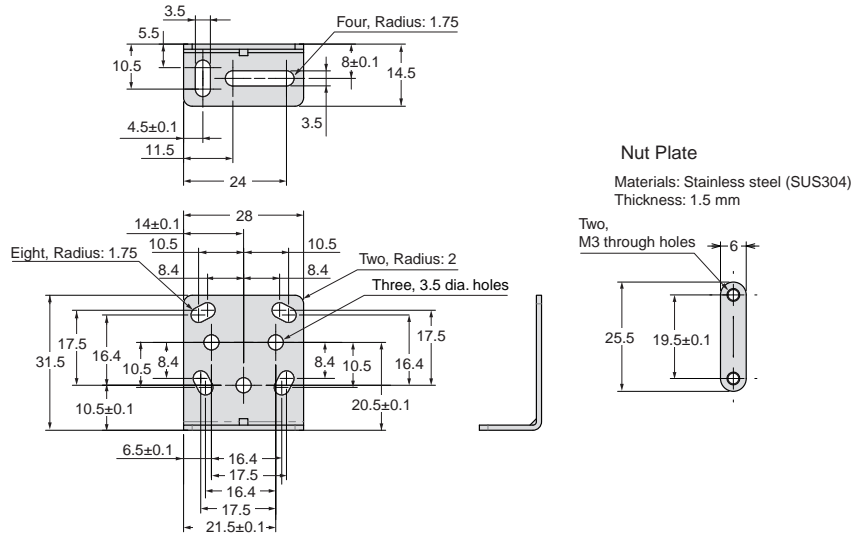

With E39-L190 Mounting Bracket Attached for Bottom Mounting

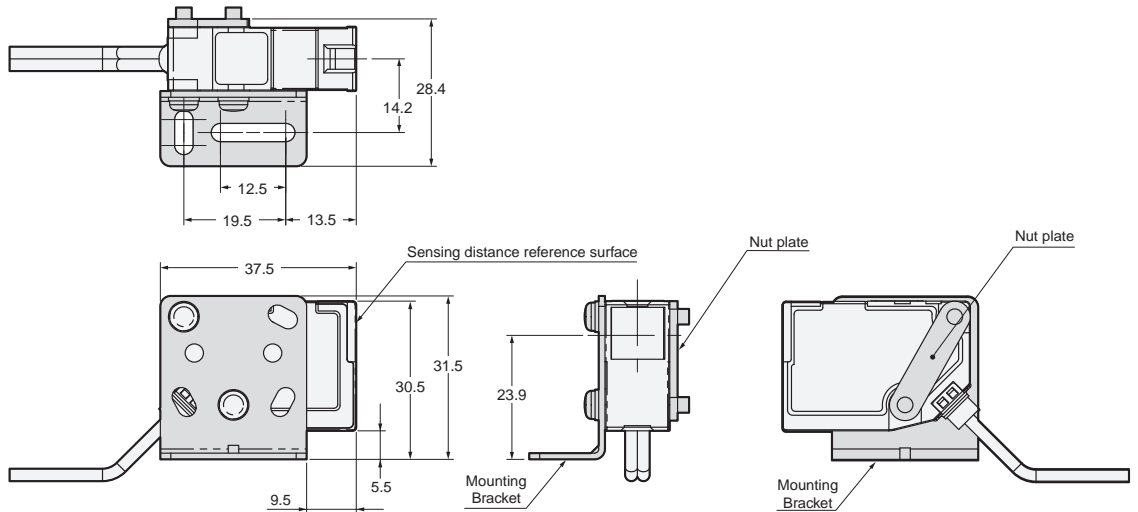

With E39-L190 Mounting Bracket Attached for Back Mounting

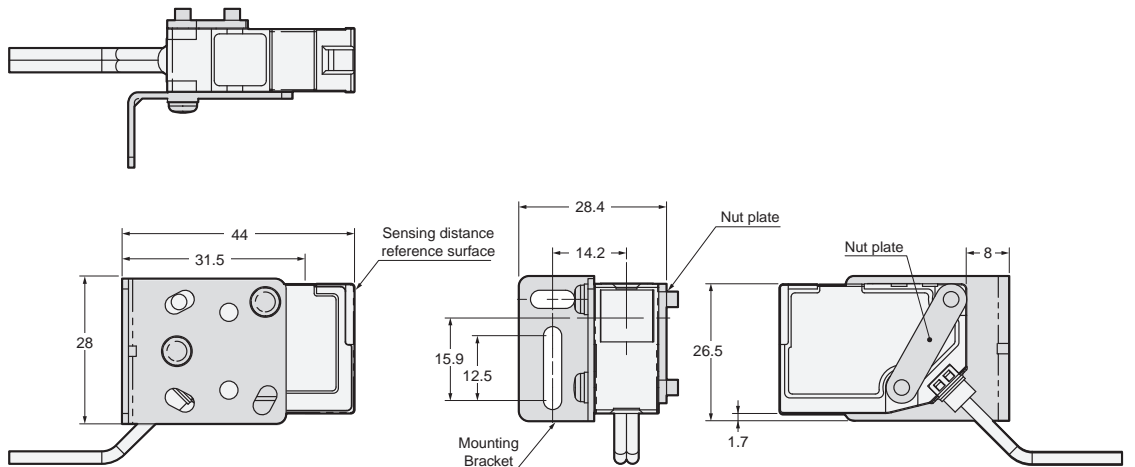

E39-L185

Mounting Bracket

Material: Stainless steel (SUS304)
 Thickness: 1.2 mm
 Accessories: Phillips screws (M3x18, P = 0.5, stainless steel): 2
 Nut plate: 1

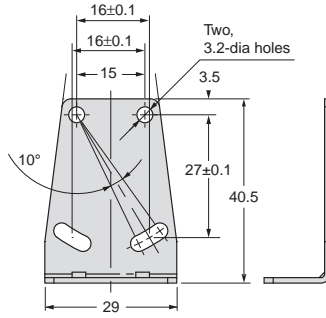
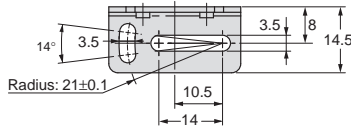

Nut Plate

Material: Stainless steel (SUS304)
 Thickness: 1.5 mm

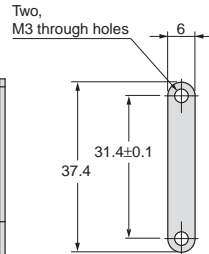

With E39-L185 Mounting Bracket Attached

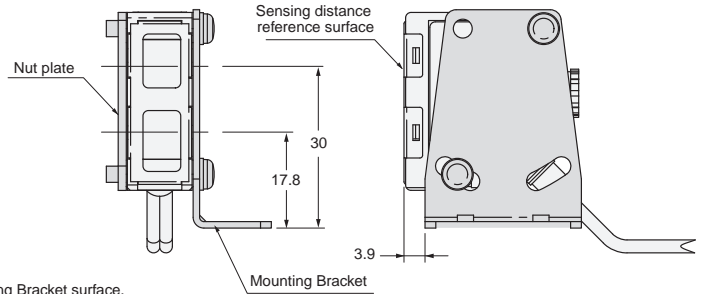
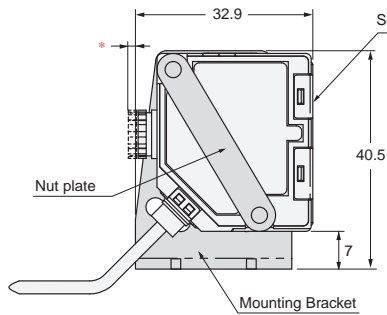
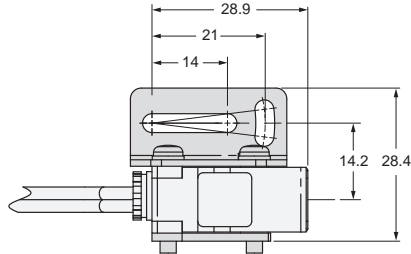

* When adjusted, the adjuster extends 0.8 mm from the Mounting Bracket surface.

E39-L186

Mounting Bracket

Material: Stainless steel (SUS304)
 Thickness: 1.2 mm
 Accessories: Phillips screws (M3x18, P = 0.5, stainless steel): 2
 Nut plate: 1

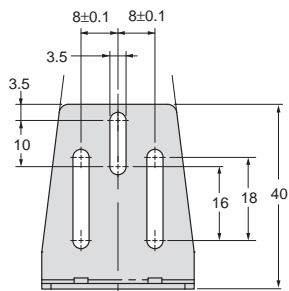
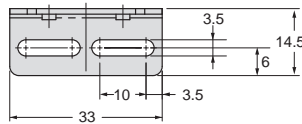

Nut Plate

Material: Stainless steel (SUS304)
 Thickness: 1.5 mm

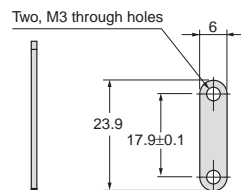

With E39-L186 Mounting Bracket Attached for Bottom Mounting

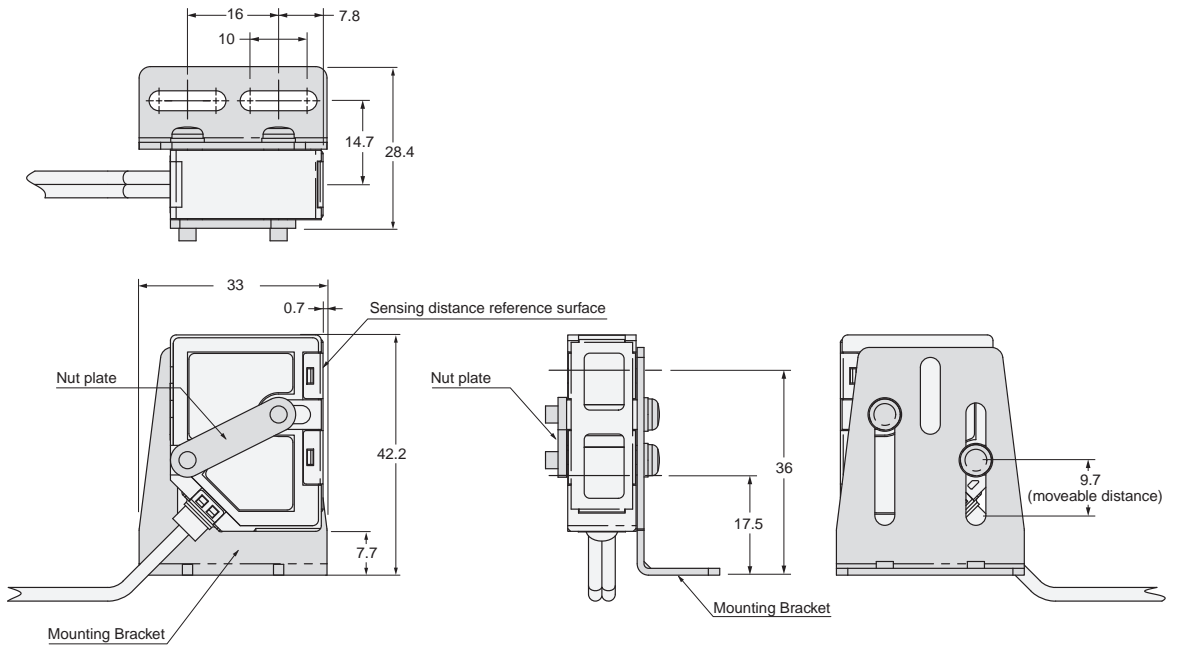

With E39-L186 Mounting Bracket Attached for Back Mounting

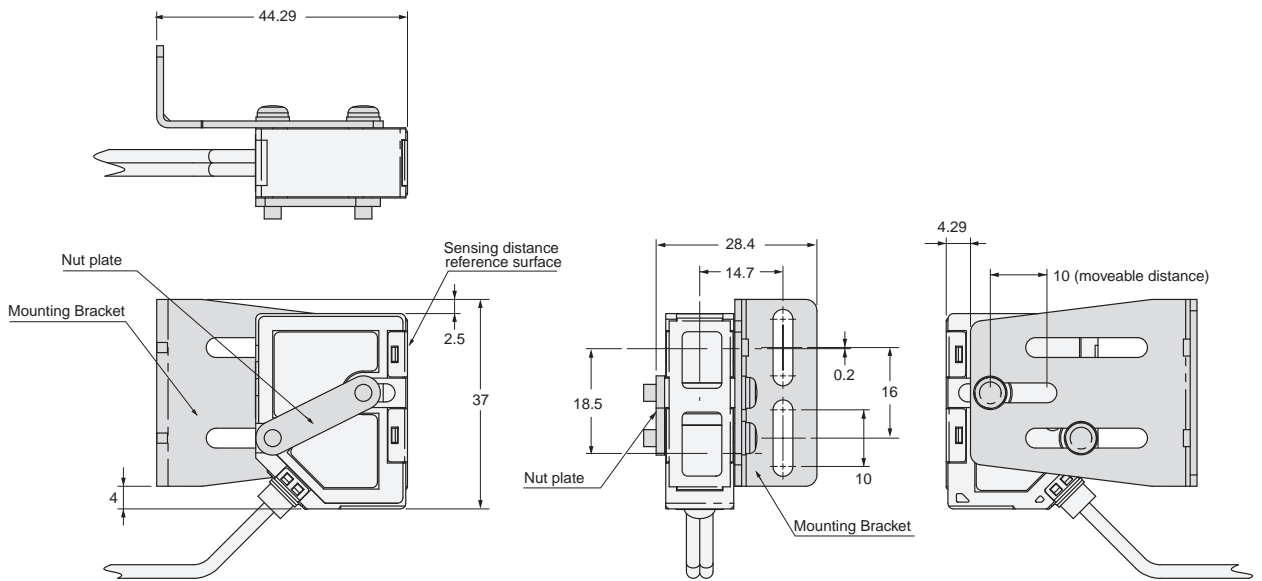

E39-L187

Mounting Bracket
 Material: Stainless steel (SUS304)
 Thickness: 1.2 mm
 Accessories: Phillips screws (M3x18, P = 0.5, stainless steel): 2
 Nut plate: 1

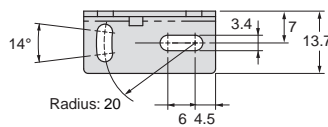

Nut Plate
 Material: Stainless steel (SUS304)
 Thickness: 1.5 mm

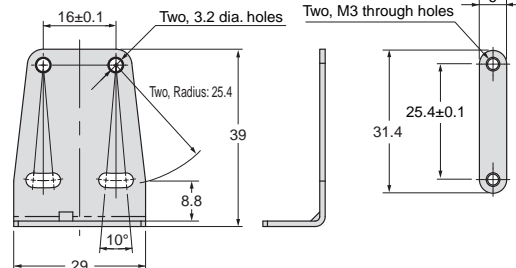

With E39-L187 Mounting Bracket Attached

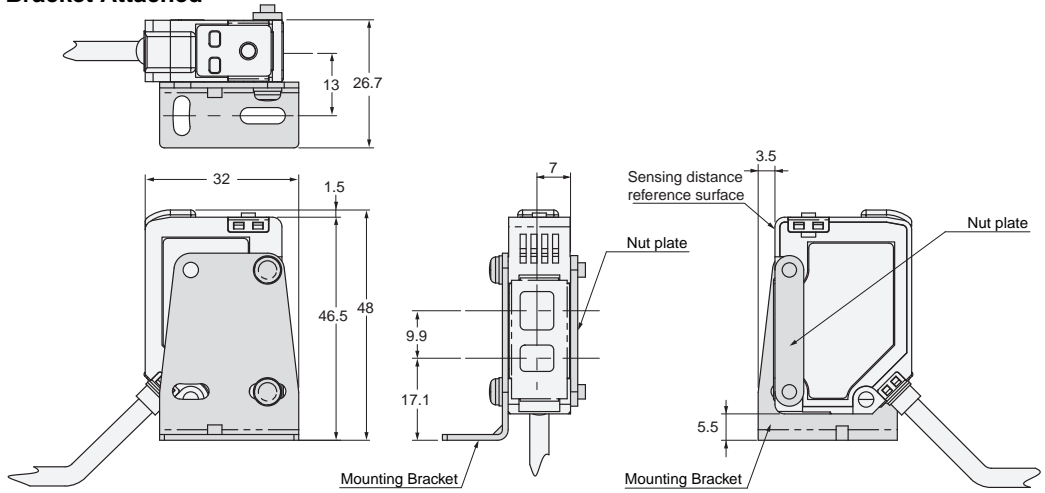

E39-L188

Mounting Bracket

Material: Stainless steel (SUS304)

Thickness: 1.2 mm

Accessories: Phillips screws (M3x18, P = 0.5, stainless steel): 2

Nut plate: 1

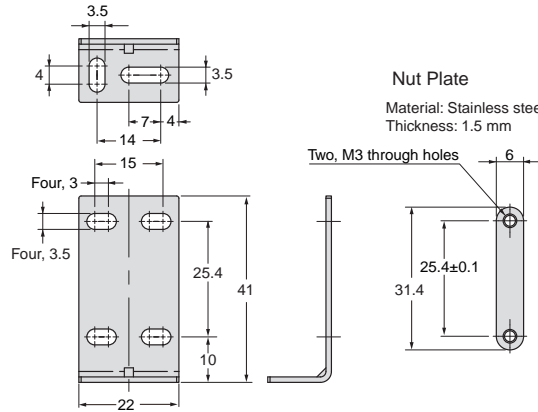

Nut Plate

Material: Stainless steel (SUS304)

Thickness: 1.5 mm

With E39-L188 Mounting Bracket Attached

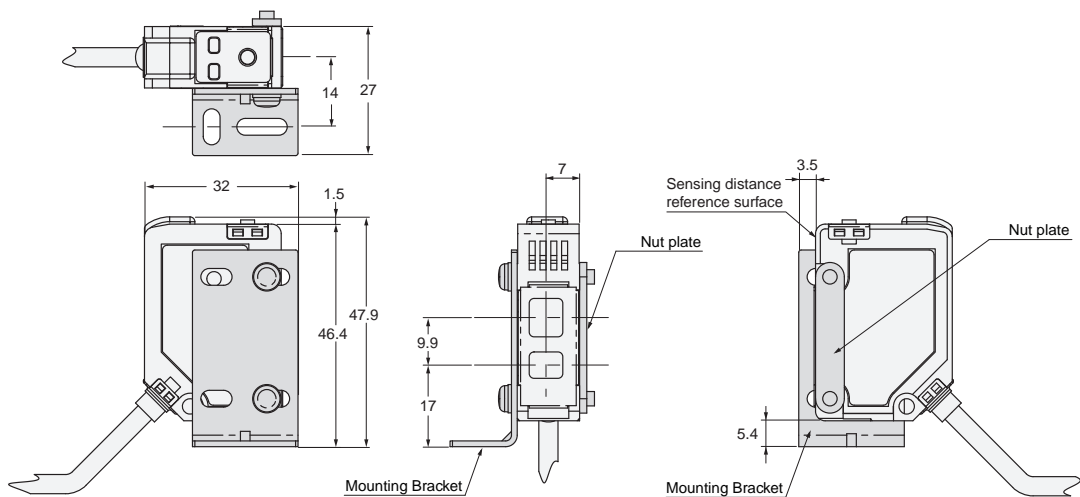

Wire-saving Connectors

Master Connector
E3X-CN21

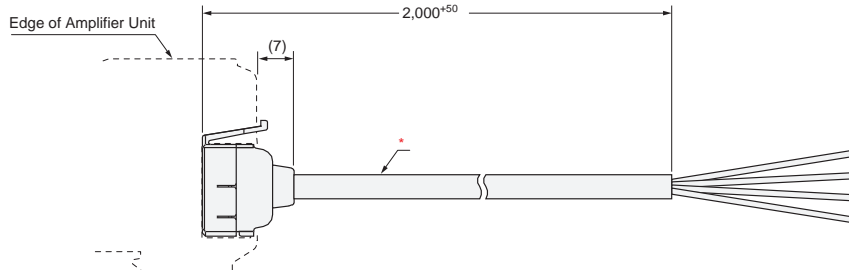

*4-dia. cable with 4 conductors, Standard cable length: 2 m (Conductor cross-section: 0.2 mm² (AWG24), Insulation diameter: 1.1 mm)

Slave Connector
E3X-CN22

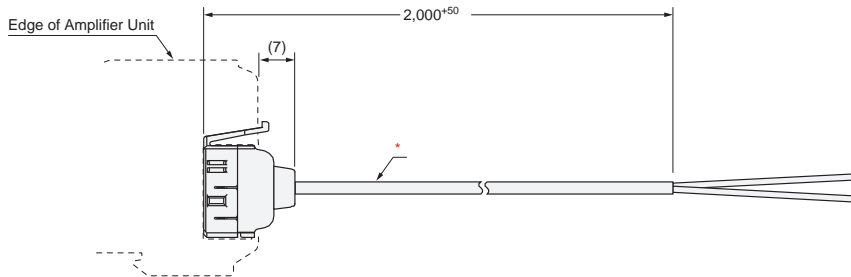

*4-dia. cable with 2 conductors, Standard cable length: 2 m (Conductor cross-section: 0.2 mm² (AWG24), Insulation diameter: 1.1 mm)

Sensor I/O Connectors

Straight

XS3F-M8_4S_

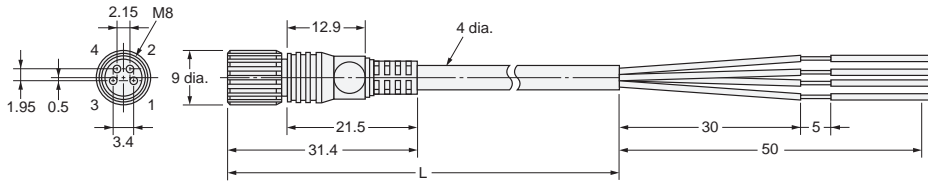

L-shaped

XS3F-M8_4A_

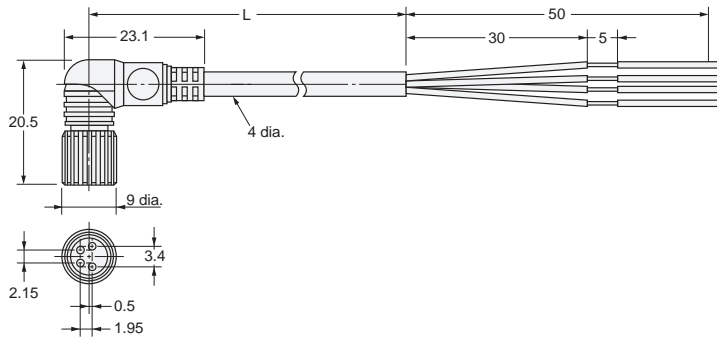

Amplifier Unit Mounting Bracket
E39-L143

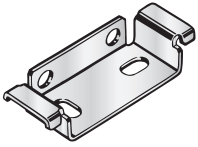

Material: Stainless steel (SUS304)

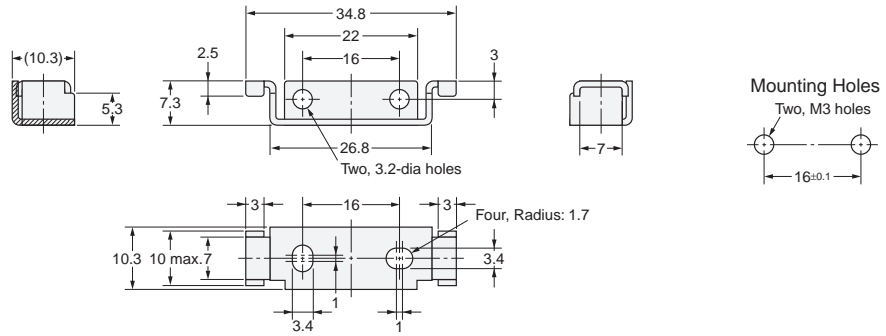

DIN Track
PFP-100N
PFP-50N



Material: Aluminum

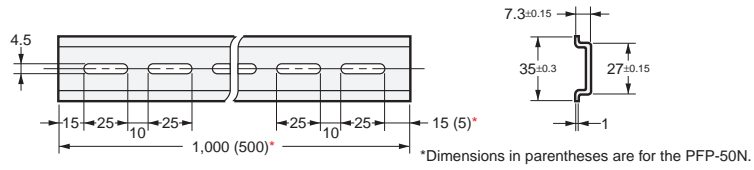

PFP-100N2



Material: Aluminum

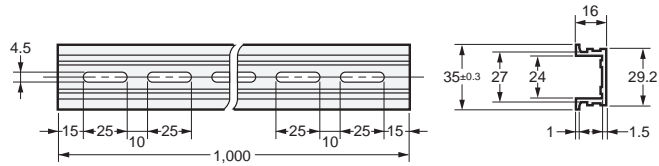

End Plate
PFP-M



Materials: Iron, zinc plating

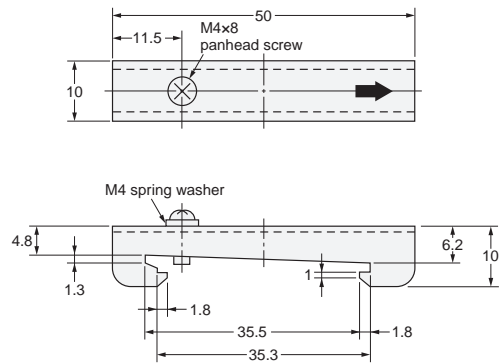

Terms and Conditions of Sale

1. **Offer; Acceptance.** These terms and conditions (these "**Terms**") are deemed part of all quotes, agreements, purchase orders, acknowledgments, price lists, catalogs, manuals, brochures and other documents, whether electronic or in writing, relating to the sale of products or services (collectively, the "**Products**") by Omron Electronics LLC and its subsidiary companies ("**Omron**"). Omron objects to any terms or conditions proposed in Buyer's purchase order or other documents which are inconsistent with, or in addition to, these Terms.
2. **Prices; Payment Terms.** All prices stated are current, subject to change without notice by Omron. Omron reserves the right to increase or decrease prices on any unshipped portions of outstanding orders. Payments for Products are due net 30 days unless otherwise stated in the invoice.
3. **Discounts.** Cash discounts, if any, will apply only on the net amount of invoices sent to Buyer after deducting transportation charges, taxes and duties, and will be allowed only if (i) the invoice is paid according to Omron's payment terms and (ii) Buyer has no past due amounts.
4. **Interest.** Omron, at its option, may charge Buyer 1-1/2% interest per month or the maximum legal rate, whichever is less, on any balance not paid within the stated terms.
5. **Orders.** Omron will accept no order less than \$200 net billing.
6. **Governmental Approvals.** Buyer shall be responsible for, and shall bear all costs involved in, obtaining any government approvals required for the importation or sale of the Products.
7. **Taxes.** All taxes, duties and other governmental charges (other than general real property and income taxes), including any interest or penalties thereon, imposed directly or indirectly on Omron or required to be collected directly or indirectly by Omron for the manufacture, production, sale, delivery, importation, consumption or use of the Products sold hereunder (including customs duties and sales, excise, use, turnover and license taxes) shall be charged to and remitted by Buyer to Omron.
8. **Financial.** If the financial position of Buyer at any time becomes unsatisfactory to Omron, Omron reserves the right to stop shipments or require satisfactory security or payment in advance. If Buyer fails to make payment or otherwise comply with these Terms or any related agreement, Omron may (without liability and in addition to other remedies) cancel any unshipped portion of Products sold hereunder and stop any Products in transit until Buyer pays all amounts, including amounts payable hereunder, whether or not then due, which are owing to it by Buyer. Buyer shall in any event remain liable for all unpaid accounts.
9. **Cancellation; Etc.** Orders are not subject to rescheduling or cancellation unless Buyer indemnifies Omron against all related costs or expenses.
10. **Force Majeure.** Omron shall not be liable for any delay or failure in delivery resulting from causes beyond its control, including earthquakes, fires, floods, strikes or other labor disputes, shortage of labor or materials, accidents to machinery, acts of sabotage, riots, delay in or lack of transportation or the requirements of any government authority.
11. **Shipping; Delivery.** Unless otherwise expressly agreed in writing by Omron:
 - a. Shipments shall be by a carrier selected by Omron; Omron will not drop ship except in "break down" situations.
 - b. Such carrier shall act as the agent of Buyer and delivery to such carrier shall constitute delivery to Buyer;
 - c. All sales and shipments of Products shall be FOB shipping point (unless otherwise stated in writing by Omron), at which point title and risk of loss shall pass from Omron to Buyer; provided that Omron shall retain a security interest in the Products until the full purchase price is paid;
 - d. Delivery and shipping dates are estimates only; and
 - e. Omron will package Products as it deems proper for protection against normal handling and extra charges apply to special conditions.
12. **Claims.** Any claim by Buyer against Omron for shortage or damage to the Products occurring before delivery to the carrier must be presented in writing to Omron within 30 days of receipt of shipment and include the original transportation bill signed by the carrier noting that the carrier received the Products from Omron in the condition claimed.
13. **Warranties.** (a) **Exclusive Warranty.** Omron's exclusive warranty is that the Products will be free from defects in materials and workmanship for a period of twelve months from the date of sale by Omron (or such other period expressed in writing by Omron). Omron disclaims all other warranties, express or implied. (b) **Limitations.** OMRON MAKES NO WARRANTY OR REPRESENTATION, EXPRESS OR IMPLIED, ABOUT NON-INFRINGEMENT, MERCHANTABILITY OR FITNESS FOR A PARTICULAR PURPOSE OF THE PRODUCTS. BUYER ACKNOWLEDGES THAT IT ALONE HAS DETERMINED THAT THE PRODUCTS WILL SUITABLY MEET THE REQUIREMENTS OF THEIR INTENDED USE. Omron further disclaims all warranties and responsibility of any type for claims or expenses based on infringement by the Products or otherwise of any intellectual property right. (c) **Buyer Remedy.** Omron's sole obligation hereunder shall be, at Omron's election, to (i) replace (in the form originally shipped with Buyer responsible for labor charges for removal or replacement thereof) the non-complying Product, (ii) repair the non-complying Product, or (iii) repay or credit Buyer an amount equal to the purchase price of the non-complying Product; provided that in no event shall Omron be responsible for warranty, repair, indemnity or any other claims or expenses regarding the Products unless Omron's analysis confirms that the Products were properly handled, stored, installed and maintained and not subject to contamination, abuse, misuse or inappropriate modification. Return of any Products by Buyer must be approved in writing by Omron before shipment. Omron Companies shall not be liable for the suitability or unsuitability or the results from the use of Products in combination with any electrical or electronic components, circuits, system assemblies or any other materials or substances or environments. Any advice, recommendations or information given orally or in writing, are not to be construed as an amendment or addition to the above warranty. See <http://www.omron247.com> or contact your Omron representative for published information.
14. **Limitation on Liability; Etc.** OMRON COMPANIES SHALL NOT BE LIABLE FOR SPECIAL, INDIRECT, INCIDENTAL, OR CONSEQUENTIAL DAMAGES, LOSS OF PROFITS OR PRODUCTION OR COMMERCIAL LOSS IN ANY WAY CONNECTED WITH THE PRODUCTS, WHETHER SUCH CLAIM IS BASED IN CONTRACT, WARRANTY, NEGLIGENCE OR STRICT LIABILITY. Further, in no event shall liability of Omron Companies exceed the individual price of the Product on which liability is asserted.
15. **Indemnities.** Buyer shall indemnify and hold harmless Omron Companies and their employees from and against all liabilities, losses, claims, costs and expenses (including attorney's fees and expenses) related to any claim, investigation, litigation or proceeding (whether or not Omron is a party) which arises or is alleged to arise from Buyer's acts or omissions under these Terms or in any way with respect to the Products. Without limiting the foregoing, Buyer (at its own expense) shall indemnify and hold harmless Omron and defend or settle any action brought against such Companies to the extent based on a claim that any Product made to Buyer specifications infringed intellectual property rights of another party.
16. **Property; Confidentiality.** Any intellectual property in the Products is the exclusive property of Omron Companies and Buyer shall not attempt to duplicate it in any way without the written permission of Omron. Notwithstanding any charges to Buyer for engineering or tooling, all engineering and tooling shall remain the exclusive property of Omron. All information and materials supplied by Omron to Buyer relating to the Products are confidential and proprietary, and Buyer shall limit distribution thereof to its trusted employees and strictly prevent disclosure to any third party.
17. **Export Controls.** Buyer shall comply with all applicable laws, regulations and licenses regarding (i) export of products or information; (ii) sale of products to "forbidden" or other proscribed persons; and (iii) disclosure to non-citizens of regulated technology or information.
18. **Miscellaneous.** (a) **Waiver.** No failure or delay by Omron in exercising any right and no course of dealing between Buyer and Omron shall operate as a waiver of rights by Omron. (b) **Assignment.** Buyer may not assign its rights hereunder without Omron's written consent. (c) **Law.** These Terms are governed by the law of the jurisdiction of the home office of the Omron company from which Buyer is purchasing the Products (without regard to conflict of law principles). (d) **Amendment.** These Terms constitute the entire agreement between Buyer and Omron relating to the Products, and no provision may be changed or waived unless in writing signed by the parties. (e) **Severability.** If any provision hereof is rendered ineffective or invalid, such provision shall not invalidate any other provision. (f) **Setoff.** Buyer shall have no right to set off any amounts against the amount owing in respect of this invoice. (g) **Definitions.** As used herein, "including" means "including without limitation"; and "Omron Companies" (or similar words) mean Omron Corporation and any direct or indirect subsidiary or affiliate thereof.

Certain Precautions on Specifications and Use

1. **Suitability of Use.** Omron Companies shall not be responsible for conformity with any standards, codes or regulations which apply to the combination of the Product in the Buyer's application or use of the Product. At Buyer's request, Omron will provide applicable third party certification documents identifying ratings and limitations of use which apply to the Product. This information by itself is not sufficient for a complete determination of the suitability of the Product in combination with the end product, machine, system, or other application or use. Buyer shall be solely responsible for determining appropriateness of the particular Product with respect to Buyer's application, product or system. Buyer shall take application responsibility in all cases but the following is a non-exhaustive list of applications for which particular attention must be given:
 - (i) Outdoor use, uses involving potential chemical contamination or electrical interference, or conditions or uses not described in this document.
 - (ii) Use in consumer products or any use in significant quantities.
 - (iii) Energy control systems, combustion systems, railroad systems, aviation systems, medical equipment, amusement machines, vehicles, safety equipment, and installations subject to separate industry or government regulations.
 - (iv) Systems, machines and equipment that could present a risk to life or property. Please know and observe all prohibitions of use applicable to this Product.

NEVER USE THE PRODUCT FOR AN APPLICATION INVOLVING SERIOUS RISK TO LIFE OR PROPERTY OR IN LARGE QUANTITIES WITHOUT ENSURING THAT THE SYSTEM AS A WHOLE HAS BEEN DESIGNED TO ADDRESS THE RISKS, AND THAT THE OMRON'S PRODUCT IS PROPERLY RATED AND INSTALLED FOR THE INTENDED USE WITHIN THE OVERALL EQUIPMENT OR SYSTEM.
2. **Programmable Products.** Omron Companies shall not be responsible for the user's programming of a programmable Product, or any consequence thereof.
3. **Performance Data.** Data presented in Omron Company websites, catalogs and other materials is provided as a guide for the user in determining suitability and does not constitute a warranty. It may represent the result of Omron's test conditions, and the user must correlate it to actual application requirements. Actual performance is subject to the Omron's Warranty and Limitations of Liability.
4. **Change in Specifications.** Product specifications and accessories may be changed at any time based on improvements and other reasons. It is our practice to change part numbers when published ratings or features are changed, or when significant construction changes are made. However, some specifications of the Product may be changed without any notice. When in doubt, special part numbers may be assigned to fix or establish key specifications for your application. Please consult with your Omron's representative at any time to confirm actual specifications of purchased Product.
5. **Errors and Omissions.** Information presented by Omron Companies has been checked and is believed to be accurate; however, no responsibility is assumed for clerical, typographical or proofreading errors or omissions.

OMRON AUTOMATION AND SAFETY • THE AMERICAS HEADQUARTERS • Chicago, IL USA • 847.843.7900 • 800.556.6766 • www.omron247.com

OMRON CANADA, INC. • HEAD OFFICE

Toronto, ON, Canada • 416.286.6465 • 866.986.6766 • www.omron247.com

OMRON ELECTRONICS DE MEXICO • HEAD OFFICE

México DF • 52.55.59.01.43.00 • 01-800-226-6766 • mela@omron.com

OMRON ELECTRONICS DE MEXICO • SALES OFFICE

Apodaca, N.L. • 52.81.11.56.99.20 • 01-800-226-6766 • mela@omron.com

OMRON ELETRÔNICA DO BRASIL LTDA • HEAD OFFICE

São Paulo, SP, Brasil • 55.11.2101.6300 • www.omron.com.br

OMRON ARGENTINA • SALES OFFICE

Cono Sur • 54.11.4783.5300

OMRON CHILE • SALES OFFICE

Santiago • 56.9.9917.3920

OTHER OMRON LATIN AMERICA SALES

54.11.4783.5300

OMRON EUROPE B.V. • Wegalaan 67-69, NL-2132 JD, Hoofddorp, The Netherlands. • +31 (0) 23 568 13 00 • www.industrial.omron.eu

Authorized Distributor:

Automation Control Systems

- Machine Automation Controllers (MAC) • Programmable Controllers (PLC)
- Operator interfaces (HMI) • Distributed I/O • Software

Drives & Motion Controls

- Servo & AC Drives • Motion Controllers & Encoders

Temperature & Process Controllers

- Single and Multi-loop Controllers

Sensors & Vision

- Proximity Sensors • Photoelectric Sensors • Fiber-Optic Sensors
- Amplified Photomicrosensors • Measurement Sensors
- Ultrasonic Sensors • Vision Sensors

Industrial Components

- RFID/Code Readers • Relays • Pushbuttons & Indicators
- Limit and Basic Switches • Timers • Counters • Metering Devices
- Power Supplies

Safety

- Laser Scanners • Safety Mats • Edges and Bumpers • Programmable Safety Controllers • Light Curtains • Safety Relays • Safety Interlock Switches