

Features

Low-cost, 10 to 30 V DC sensor for use with plastic fiber optics

- Models available with visible red (660 nm) or visible green (525 nm) LED light source
- Sleek, ultra-slim 10 mm housing, mounts to standard 35 mm DIN rail
- Solid-state, bipolar discrete outputs: one current sourcing (PNP) and one current sinking (NPN)
- High-speed models: 200-microsecond output response
- Standard models: 500-microsecond output response plus crosstalk-avoidance circuitry (for applications with multiple sensors)
- Selectable Light/Dark Operate and 40-millisecond pulse stretcher (OFF-delay), via two easy-to-operate slide switches
- 12-turn Sensitivity adjustment with relative position indicator
- LED status indicators for Power ON and Light Sensed (AID™) indication
- Models available with integral cable or an M8 quick-disconnect connector

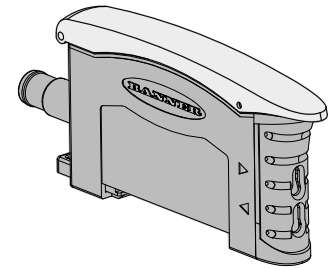

WARNING:



- **Do not use this device for personnel protection**
- Using this device for personnel protection could result in serious injury or death.
- This device does not include the self-checking redundant circuitry necessary to allow its use in personnel safety applications. A device failure or malfunction can cause either an energized (on) or de-energized (off) output condition.

Models

Red Beam (660 nm)	Green Beam (525 nm)	Response Time	Cable ⁽¹⁾	Output Type
D10AFP		500 microseconds	4-conductor 2 m (6.5 ft) Cable	Bipolar NPN/PNP Solid-state
D10AFPQ	D10AFPGQ		4-pin M8 QD	
D10AFPY	D10AFPGY	200 microseconds	4-conductor 2 m (6.5 ft) Cable	
D10AFPYQ	D10AFPGYQ		4-pin M8 QD	

The following models are no longer available for order but are still covered by the information in this document.

Green Beam (525 nm)	Response Time	Cable	Output Type
D10AFPG	500 microseconds	4-conductor 2 m (6.5 ft) Cable	Bipolar NPN/PNP Solid-state

⁽¹⁾ To order the 9 m (30 ft) PVC cable model, add the suffix "W30" to the cabled model number. For example, D10AFP W30. Models with a quick disconnect require a mating cordset.



Overview

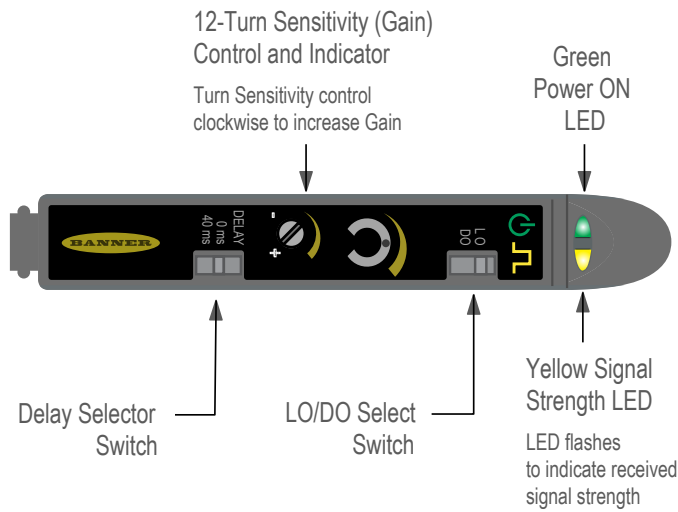

In dark operate (DO) mode, the output is ON when the target returns less light to the sensor than the configured target and OFF when the sensor detects more light than the configured/taught target. In light operate (LO) mode, the output is ON when the target returns the same or more light to the sensor and OFF when the sensor detects less light than the configured/taught target.

Installation

Installing Fibers and Housing

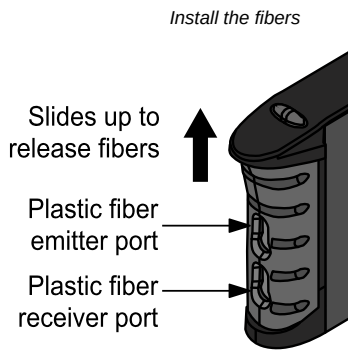

Mount the D10 on a DIN rail or the mounting bracket

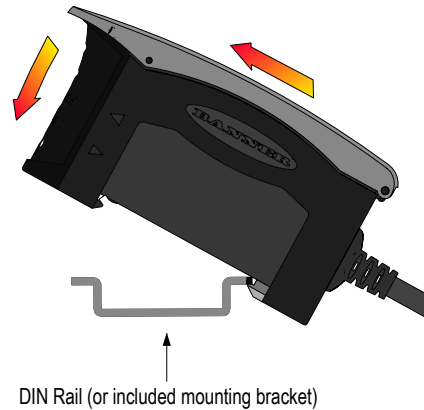

Wiring

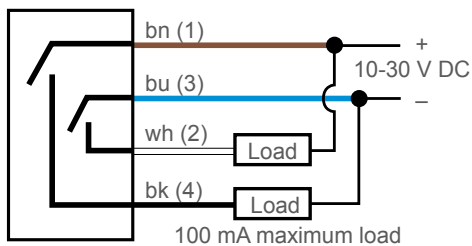

NOTE: Quick disconnect wiring diagrams are functionally identical.

Specifications

Sensing Beam

Visible red, 660 nm or Visible green, 525 nm, depending on model

Supply Voltage

10 to 30 V DC (10% max. ripple) at less than 25 mA, exclusive of load

Supply Protection Circuitry

Protected against reverse polarity and transient voltages

Output Configuration

Bipolar: 1 current sourcing (PNP) and 1 current sinking (NPN)

Output Rating

100 mA per output with short circuit protection
 OFF-state leakage current: < 10 μ A sourcing; 200 μ A sinking
 ON-state saturation voltage:
 NPN: 1.6 V at 100 mA
 PNP: 2.0 V at 100 mA

Output Protection

Protected against output short-circuit and false pulse on power-up

NOTE: Maximum 100 ms delay on power-up; outputs do not conduct during this time

Output Response Time

Standard models (with crosstalk avoidance circuitry): 500 microseconds
 High-speed models: 200 microseconds

Repeatability

Standard models: 95 microseconds
 High-speed models: 50 microseconds

Adjustments

12-turn Sensitivity potentiometer with relative position indicator; LO/DO Selection switch; 0 or 40 ms off delay switch

NOTE: Use proper ESD techniques while making adjustments under the cover.

Indicators

Two LEDs: Green and Amber
 Green ON steady: Power ON
 Amber flashing: Light Sensed Signal strength indicator (Banner's AID™ Alignment Indicating Device—the faster the flash, the more light is received)

Construction

Black ABS/polycarbonate alloy (UL94 V-0 rated) housing, clear polycarbonate cover

Environmental Rating

IP50, NEMA 1

Connections

2 m or 9 m (6.5 ft or 30 ft) attached cable, or 4-pin M8 quick-disconnect fitting; cables for QD models are purchased separately

Certifications



Banner Engineering BV
 Park Lane, Culliganlaan 2F bus 3
 1831 Diegem, BELGIUM



Operating Conditions

Operating Temperature: -10 °C to +55 °C (+14 °F to +131 °F)
 Storage Temperature: -20 °C to +85 °C (-4 °F to +185 °F)
 90% at +55 °C maximum relative humidity (non-condensing)

Required Overcurrent Protection



WARNING: Electrical connections must be made by qualified personnel in accordance with local and national electrical codes and regulations.

Overcurrent protection is required to be provided by end product application per the supplied table.

Overcurrent protection may be provided with external fusing or via Current Limiting, Class 2 Power Supply.

Supply wiring leads < 24 AWG shall not be spliced.

For additional product support, go to www.bannerengineering.com.

Supply Wiring (AWG)	Required Overcurrent Protection (A)	Supply Wiring (AWG)	Required Overcurrent Protection (A)
20	5.0	26	1.0
22	3.0	28	0.8
24	2.0	30	0.5

Dimensions

All measurements are listed in millimeters [inches], unless noted otherwise. The measurements provided are subject to change.

D10 dimensions

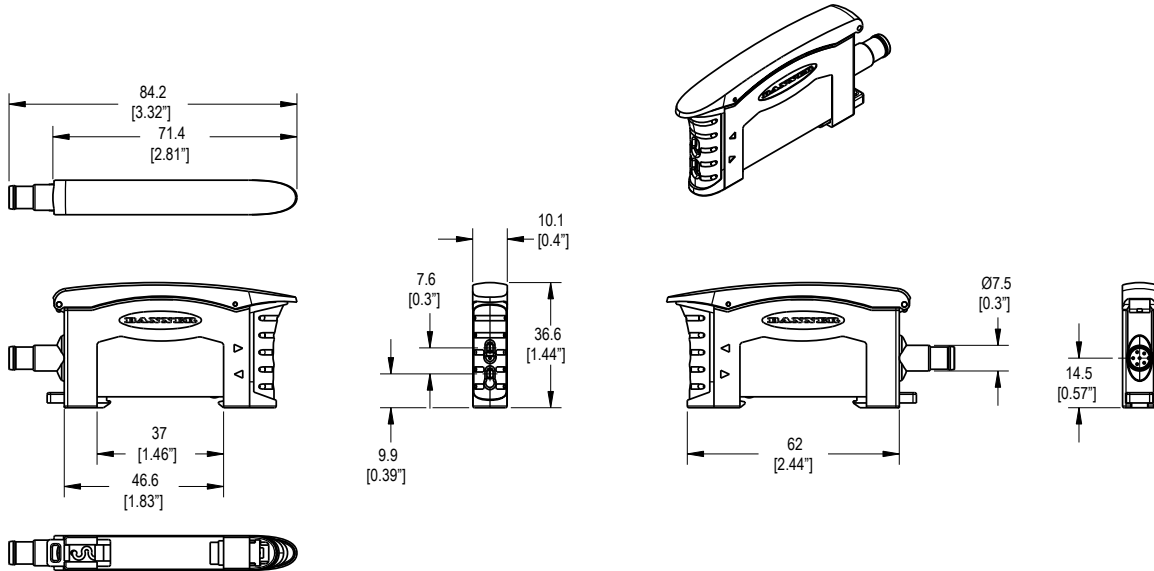

Included bracket dimensions

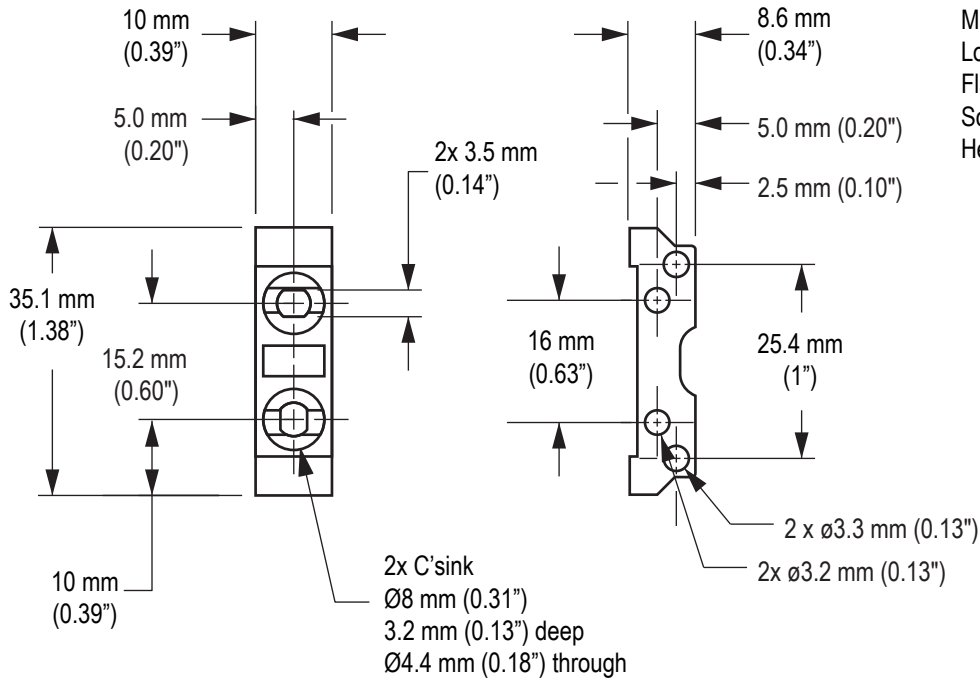

Performance Curves

Opposed Mode

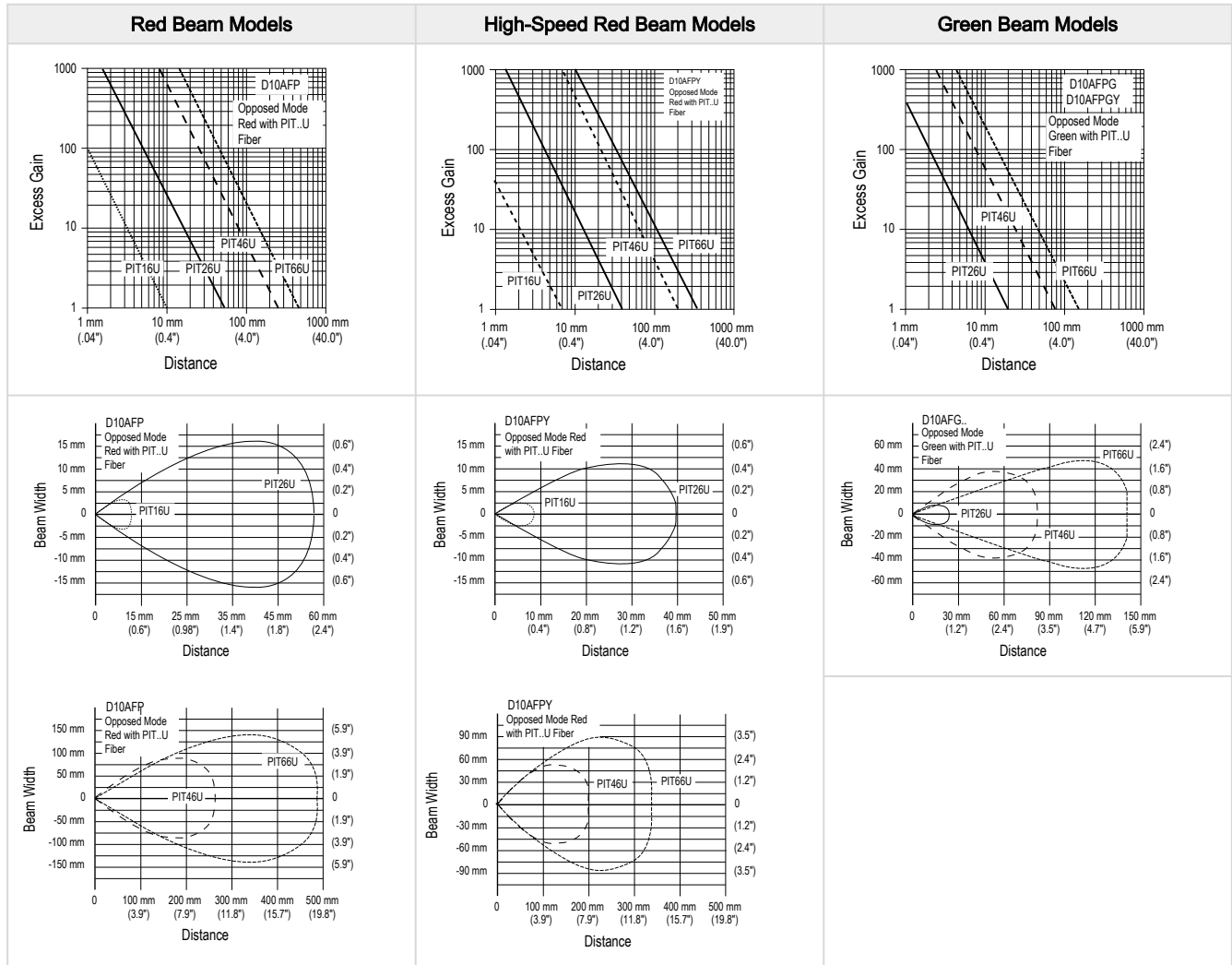

Diffuse Mode

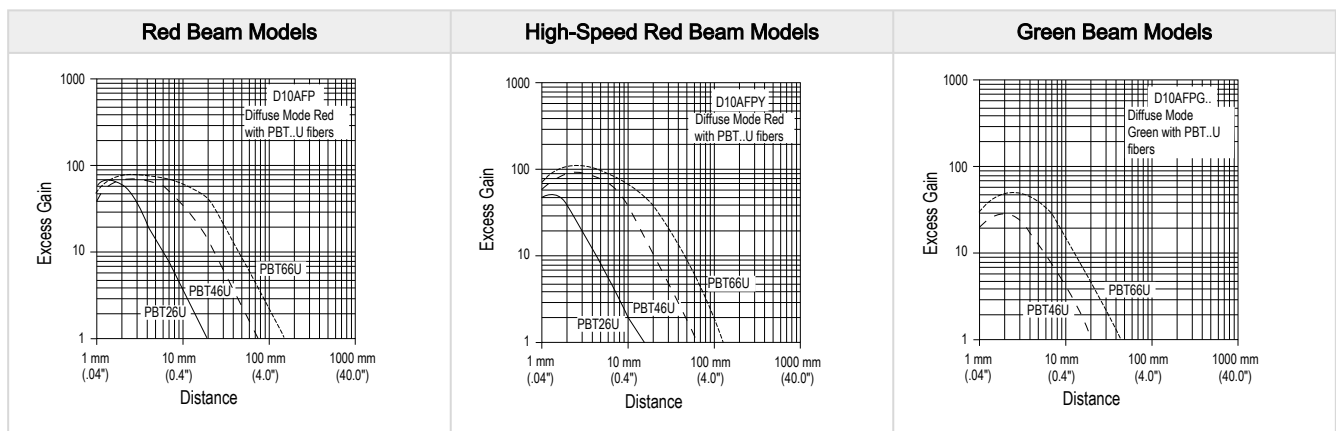

Continued on page 6

Continued from page 5

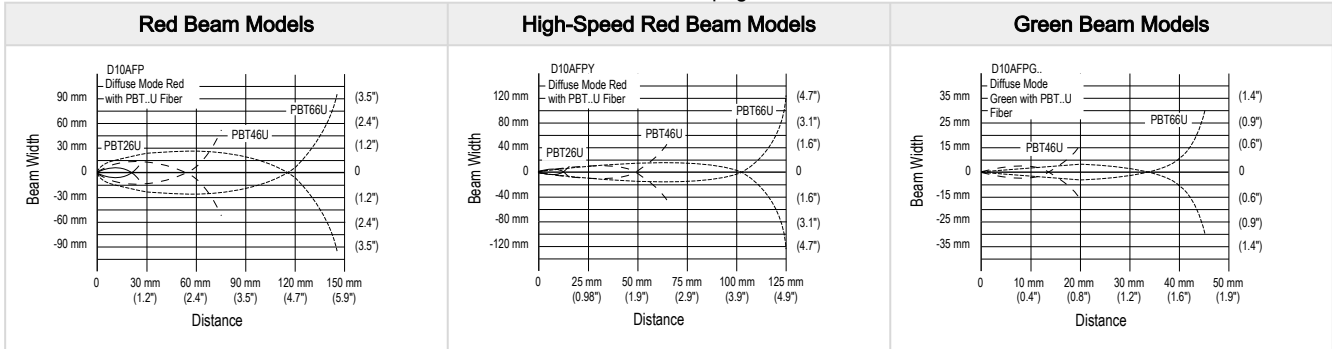

Accessories

4-Pin Single-Ended Snap-on M8 Female Cordsets				
Model	Length	Style	Dimensions	Pinout (Female)
PKG4-2	2.03 m (6.66 ft)	Straight		
PKW4Z-2	2 m (6.56 ft)	Right-Angle		

1 = Brown
 2 = White
 3 = Blue
 4 = Black

Banner Engineering Corp Limited Warranty

Banner Engineering Corp. warrants its products to be free from defects in material and workmanship for one year following the date of shipment. Banner Engineering Corp. will repair or replace, free of charge, any product of its manufacture which, at the time it is returned to the factory, is found to have been defective during the warranty period. This warranty does not cover damage or liability for misuse, abuse, or the improper application or installation of the Banner product.

THIS LIMITED WARRANTY IS EXCLUSIVE AND IN LIEU OF ALL OTHER WARRANTIES WHETHER EXPRESS OR IMPLIED (INCLUDING, WITHOUT LIMITATION, ANY WARRANTY OF MERCHANTABILITY OR FITNESS FOR A PARTICULAR PURPOSE), AND WHETHER ARISING UNDER COURSE OF PERFORMANCE, COURSE OF DEALING OR TRADE USAGE.

This Warranty is exclusive and limited to repair or, at the discretion of Banner Engineering Corp., replacement. **IN NO EVENT SHALL BANNER ENGINEERING CORP. BE LIABLE TO BUYER OR ANY OTHER PERSON OR ENTITY FOR ANY EXTRA COSTS, EXPENSES, LOSSES, LOSS OF PROFITS, OR ANY INCIDENTAL, CONSEQUENTIAL OR SPECIAL DAMAGES RESULTING FROM ANY PRODUCT DEFECT OR FROM THE USE OR INABILITY TO USE THE PRODUCT, WHETHER ARISING IN CONTRACT OR WARRANTY, STATUTE, TORT, STRICT LIABILITY, NEGLIGENCE, OR OTHERWISE.**

Banner Engineering Corp. reserves the right to change, modify or improve the design of the product without assuming any obligations or liabilities relating to any product previously manufactured by Banner Engineering Corp. Any misuse, abuse, or improper application or installation of this product or use of the product for personal protection applications when the product is identified as not intended for such purposes will void the product warranty. Any modifications to this product without prior express approval by Banner Engineering Corp will void the product warranties. All specifications published in this document are subject to change; Banner reserves the right to modify product specifications or update documentation at any time. Specifications and product information in English supersede that which is provided in any other language. For the most recent version of any documentation, refer to: www.bannerengineering.com.

For patent information, see www.bannerengineering.com/patents.