



MOTION CONTROLLER



Q series

Q173HCPU

Q172HCPU

User's Manual

● SAFETY PRECAUTIONS ●

(Please read these instructions before using this equipment.)

Before using this product, please read this manual and the relevant manuals introduced in this manual carefully and pay full attention to safety to handle the product correctly.

These precautions apply only to this product. Refer to the Users manual of the QCPU module to use for a description of the PLC system safety precautions.

In this manual, the safety instructions are ranked as "DANGER" and "CAUTION".



DANGER

Indicates that incorrect handling may cause hazardous conditions, resulting in death or severe injury.



CAUTION

Indicates that incorrect handling may cause hazardous conditions, resulting in medium or slight personal injury or physical damage.

Depending on circumstances, procedures indicated by  CAUTION may also be linked to serious results.

In any case, it is important to follow the directions for usage.

Please save this manual to make it accessible when required and always forward it to the end user.

For Safe Operations

1. Prevention of electric shocks

DANGER

- Never open the front case or terminal covers while the power is ON or the unit is running, as this may lead to electric shocks.
- Never run the unit with the front case or terminal cover removed. The high voltage terminal and charged sections will be exposed and may lead to electric shocks.
- Never open the front case or terminal cover at times other than wiring work or periodic inspections even if the power is OFF. The insides of the Motion controller and servo amplifier are charged and may lead to electric shocks.
- Completely turn off the externally supplied power used in the system before mounting or removing the module, performing wiring work, or inspections. Failing to do so may lead to electric shocks.
- When performing wiring work or inspections, turn the power OFF, wait at least ten minutes, and then check the voltage with a tester, etc.. Failing to do so may lead to electric shocks.
- Be sure to ground the Motion controller, servo amplifier and servomotor. (Ground resistance : 100 Ω or less) Do not ground commonly with other devices.
- The wiring work and inspections must be done by a qualified technician.
- Wire the units after installing the Motion controller, servo amplifier and servomotor. Failing to do so may lead to electric shocks or damage.
- Never operate the switches with wet hands, as this may lead to electric shocks.
- Do not damage, apply excessive stress, place heavy things on or sandwich the cables, as this may lead to electric shocks.
- Do not touch the Motion controller, servo amplifier or servomotor terminal blocks while the power is ON, as this may lead to electric shocks.
- Do not touch the built-in power supply, built-in grounding or signal wires of the Motion controller and servo amplifier, as this may lead to electric shocks.

2. For fire prevention

CAUTION

- Install the Motion controller, servo amplifier, servomotor and regenerative resistor on incombustible. Installing them directly or close to combustibles will lead to fire.
- If a fault occurs in the Motion controller or servo amplifier, shut the power OFF at the servo amplifier's power source. If a large current continues to flow, fire may occur.
- When using a regenerative resistor, shut the power OFF with an error signal. The regenerative resistor may abnormally overheat due to a fault in the regenerative transistor, etc., and may lead to fire.
- Always take heat measures such as flame proofing for the inside of the control panel where the servo amplifier or regenerative resistor is installed and for the wires used. Failing to do so may lead to fire.
- Do not damage, apply excessive stress, place heavy things on or sandwich the cables, as this may lead to fire.

3. For injury prevention

CAUTION

- Do not apply a voltage other than that specified in the instruction manual on any terminal. Doing so may lead to destruction or damage.
- Do not mistake the terminal connections, as this may lead to destruction or damage.
- Do not mistake the polarity (+ / -), as this may lead to destruction or damage.
- Do not touch the heat radiating fins of controller or servo amplifier, regenerative resistor and servomotor, etc., while the power is ON and for a short time after the power is turned OFF. In this timing, these parts become very hot and may lead to burns.
- Always turn the power OFF before touching the servomotor shaft or coupled machines, as these parts may lead to injuries.
- Do not go near the machine during test operations or during operations such as teaching. Doing so may lead to injuries.

4. Various precautions

Strictly observe the following precautions.

Mistaken handling of the unit may lead to faults, injuries or electric shocks.

(1) System structure

CAUTION

- Always install a leakage breaker on the Motion controller and servo amplifier power source.
- If installation of an electromagnetic contactor for power shut off during an error, etc., is specified in the instruction manual for the servo amplifier, etc., always install the electromagnetic contactor.
- Install the emergency stop circuit externally so that the operation can be stopped immediately and the power shut off.
- Use the Motion controller, servo amplifier, servomotor and regenerative resistor with the correct combinations listed in the instruction manual. Other combinations may lead to fire or faults.
- Use the Motion controller, base unit and motion module with the correct combinations listed in the instruction manual. Other combinations may lead to faults.
- If safety standards (ex., robot safety rules, etc.,) apply to the system using the Motion controller, servo amplifier and servomotor, make sure that the safety standards are satisfied.
- Construct a safety circuit externally of the Motion controller or servo amplifier if the abnormal operation of the Motion controller or servo amplifier differ from the safety directive operation in the system.
- In systems where coasting of the servomotor will be a problem during the forced stop, emergency stop, servo OFF or power supply OFF, use dynamic brakes.
- Make sure that the system considers the coasting amount even when using dynamic brakes.
- In systems where perpendicular shaft dropping may be a problem during the forced stop, emergency stop, servo OFF or power supply OFF, use both dynamic brakes and electromagnetic brakes.

CAUTION

- The dynamic brakes must be used only on errors that cause the forced stop, emergency stop, or servo OFF. These brakes must not be used for normal braking.
- The brakes (electromagnetic brakes) assembled into the servomotor are for holding applications, and must not be used for normal braking.
- The system must have a mechanical allowance so that the machine itself can stop even if the stroke limits switch is passed through at the max. speed.
- Use wires and cables that have a wire diameter, heat resistance and bending resistance compatible with the system.
- Use wires and cables within the length of the range described in the instruction manual.
- The ratings and characteristics of the parts (other than Motion controller, servo amplifier and servomotor) used in a system must be compatible with the Motion controller, servo amplifier and servomotor.
- Install a cover on the shaft so that the rotary parts of the servomotor are not touched during operation.
- There may be some cases where holding by the electromagnetic brakes is not possible due to the life or mechanical structure (when the ball screw and servomotor are connected with a timing belt, etc.). Install a stopping device to ensure safety on the machine side.

(2) Parameter settings and programming

CAUTION

- Set the parameter values to those that are compatible with the Motion controller, servo amplifier, servomotor and regenerative resistor model and the system application. The protective functions may not function if the settings are incorrect.
- The regenerative resistor model and capacity parameters must be set to values that conform to the operation mode, servo amplifier and servo power supply module. The protective functions may not function if the settings are incorrect.
- Set the mechanical brake output and dynamic brake output validity parameters to values that are compatible with the system application. The protective functions may not function if the settings are incorrect.
- Set the stroke limit input validity parameter to a value that is compatible with the system application. The protective functions may not function if the setting is incorrect.
- Set the servomotor encoder type (increment, absolute position type, etc.) parameter to a value that is compatible with the system application. The protective functions may not function if the setting is incorrect.
- Set the servomotor capacity and type (standard, low-inertia, flat, etc.) parameter to values that are compatible with the system application. The protective functions may not function if the settings are incorrect.
- Set the servo amplifier capacity and type parameters to values that are compatible with the system application. The protective functions may not function if the settings are incorrect.
- Use the program commands for the program with the conditions specified in the instruction manual.

CAUTION

- Set the sequence function program capacity setting, device capacity, latch validity range, I/O assignment setting, and validity of continuous operation during error detection to values that are compatible with the system application. The protective functions may not function if the settings are incorrect.
- Some devices used in the program have fixed applications, so use these with the conditions specified in the instruction manual.
- The input devices and data registers assigned to the link will hold the data previous to when communication is terminated by an error, etc. Thus, an error correspondence interlock program specified in the instruction manual must be used.
- Use the interlock program specified in the intelligent function module's instruction manual for the program corresponding to the intelligent function module.

(3) Transportation and installation

CAUTION

- Transport the product with the correct method according to the mass.
- Use the servomotor suspension bolts only for the transportation of the servomotor. Do not transport the servomotor with machine installed on it.
- Do not stack products past the limit.
- When transporting the Motion controller or servo amplifier, never hold the connected wires or cables.
- When transporting the servomotor, never hold the cables, shaft or detector.
- When transporting the Motion controller or servo amplifier, never hold the front case as it may fall off.
- When transporting, installing or removing the Motion controller or servo amplifier, never hold the edges.
- Install the unit according to the instruction manual in a place where the mass can be withstood.
- Do not get on or place heavy objects on the product.
- Always observe the installation direction.
- Keep the designated clearance between the Motion controller or servo amplifier and control panel inner surface or the Motion controller and servo amplifier, Motion controller or servo amplifier and other devices.
- Do not install or operate Motion controller, servo amplifiers or servomotors that are damaged or that have missing parts.
- Do not block the intake/outtake ports of the Motion controller, servo amplifier and servomotor with cooling fan.
- Do not allow conductive matter such as screw or cutting chips or combustible matter such as oil enter the Motion controller, servo amplifier or servomotor.
- The Motion controller, servo amplifier and servomotor are precision machines, so do not drop or apply strong impacts on them.
- Securely fix the Motion controller, servo amplifier and servomotor to the machine according to the instruction manual. If the fixing is insufficient, these may come off during operation.

⚠ CAUTION

- Always install the servomotor with reduction gears in the designated direction. Failing to do so may lead to oil leaks.
- Store and use the unit in the following environmental conditions.

Environment	Conditions	
	Motion controller/Servo amplifier	Servomotor
Ambient temperature	According to each instruction manual.	0°C to +40°C (With no freezing) (32°F to +104°F)
Ambient humidity	According to each instruction manual.	80% RH or less (With no dew condensation)
Storage temperature	According to each instruction manual.	-20°C to +65°C (-4°F to +149°F)
Atmosphere	Indoors (where not subject to direct sunlight). No corrosive gases, flammable gases, oil mist or dust must exist	
Altitude	1000m (3280.84ft.) or less above sea level	
Vibration	According to each instruction manual	

- When coupling with the synchronous encoder or servomotor shaft end, do not apply impact such as by hitting with a hammer. Doing so may lead to detector damage.
- Do not apply a load larger than the tolerable load onto the synchronous encoder and servomotor shaft. Doing so may lead to shaft breakage.
- When not using the module for a long time, disconnect the power line from the Motion controller or servo amplifier.
- Place the Motion controller and servo amplifier in static electricity preventing vinyl bags and store.
- When storing for a long time, please contact with our sales representative.
Also, execute a trial operation.

(4) Wiring

⚠ CAUTION

- Correctly and securely wire the wires. Reconfirm the connections for mistakes and the terminal screws for tightness after wiring. Failing to do so may lead to run away of the servomotor.
- After wiring, install the protective covers such as the terminal covers to the original positions.
- Do not install a phase advancing capacitor, surge absorber or radio noise filter (option FR-BIF) on the output side of the servo amplifier.
- Correctly connect the output side (terminal U, V, W) and ground. Incorrect connections will lead the servomotor to operate abnormally.
- Do not connect a commercial power supply to the servomotor, as this may lead to trouble.
- Do not mistake the direction of the surge absorbing diode installed on the DC relay for the control signal output of brake signals, etc. Incorrect installation may lead to signals not being output when trouble occurs or the protective functions not functioning.

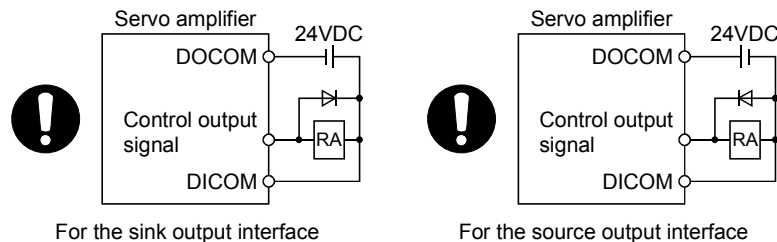

- Do not connect or disconnect the connection cables between each unit, the encoder cable or PLC expansion cable while the power is ON.
- Securely tighten the cable connector fixing screws and fixing mechanisms. Insufficient fixing may lead to the cables coming off during operation.
- Do not bundle the power line or cables.

(5) Trial operation and adjustment

⚠ CAUTION

- Confirm and adjust the program and each parameter before operation. Unpredictable movements may occur depending on the machine.
- Extreme adjustments and changes may lead to unstable operation, so never make them.
- When using the absolute position system function, on starting up, and when the Motion controller or absolute value motor has been replaced, always perform a home position return.
- Before starting test operation, set the parameter speed limit value to the slowest value, and make sure that operation can be stopped immediately by the forced stop, etc. if a hazardous state occurs.

(6) Usage methods

⚠ CAUTION

- Immediately turn OFF the power if smoke, abnormal sounds or odors are emitted from the Motion controller, servo amplifier or servomotor.
- Always execute a test operation before starting actual operations after the program or parameters have been changed or after maintenance and inspection.
- Do not attempt to disassemble and repair the units excluding a qualified technician whom our company recognized.
- Do not make any modifications to the unit.
- Keep the effect or electromagnetic obstacles to a minimum by installing a noise filter or by using wire shields, etc. Electromagnetic obstacles may affect the electronic devices used near the Motion controller or servo amplifier.
- When using the CE Mark-compliant equipment, refer to this manual for the Motion controllers and refer to the corresponding EMC guideline information for the servo amplifiers, inverters and other equipment.
- Use the units with the following conditions.

Item	Conditions
Input power	According to each instruction manual.
Input frequency	According to each instruction manual.
Tolerable momentary power failure	According to each instruction manual.

(7) Corrective actions for errors

⚠ CAUTION

- If an error occurs in the self diagnosis of the Motion controller or servo amplifier, confirm the check details according to the instruction manual, and restore the operation.
- If a dangerous state is predicted in case of a power failure or product failure, use a servomotor with electromagnetic brakes or install a brake mechanism externally.
- Use a double circuit construction so that the electromagnetic brake operation circuit can be operated by emergency stop signals set externally.

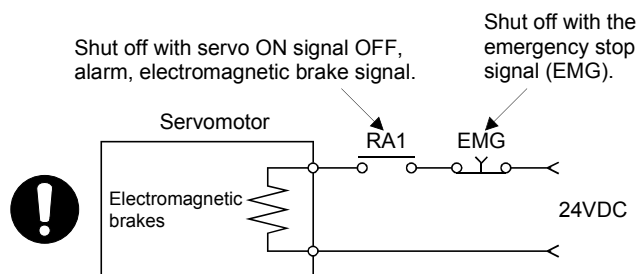

- If an error occurs, remove the cause, secure the safety and then resume operation after alarm release.
- The unit may suddenly resume operation after a power failure is restored, so do not go near the machine. (Design the machine so that personal safety can be ensured even if the machine restarts suddenly.)

(8) Maintenance, inspection and part replacement

CAUTION

- Perform the daily and periodic inspections according to the instruction manual.
- Perform maintenance and inspection after backing up the program and parameters for the Motion controller and servo amplifier.
- Do not place fingers or hands in the clearance when opening or closing any opening.
- Periodically replace consumable parts such as batteries according to the instruction manual.
- Do not touch the lead sections such as ICs or the connector contacts.
- Before touching the module, always touch grounded metal, etc. to discharge static electricity from human body. Failure to do so may cause the module to fail or malfunction.
- Do not directly touch the module's conductive parts and electronic components. Touching them could cause an operation failure or give damage to the module.
- Do not place the Motion controller or servo amplifier on metal that may cause a power leakage or wood, plastic or vinyl that may cause static electricity buildup.
- Do not perform a megger test (insulation resistance measurement) during inspection.
- When replacing the Motion controller or servo amplifier, always set the new module settings correctly.
- When the Motion controller or absolute value motor has been replaced, carry out a home position return operation using one of the following methods, otherwise position displacement could occur.
 - 1) After writing the servo data to the Motion controller using programming software, switch on the power again, then perform a home position return operation.
 - 2) Using the backup function of the programming software, load the data backed up before replacement.
- After maintenance and inspections are completed, confirm that the position detection of the absolute position detector function is correct.
- Do not drop or impact the battery installed to the module. Doing so may damage the battery, causing battery liquid to leak in the battery. Do not use the dropped or impacted battery, but dispose of it.
- Do not short circuit, charge, overheat, incinerate or disassemble the batteries.
- The electrolytic capacitor will generate gas during a fault, so do not place your face near the Motion controller or servo amplifier.
- The electrolytic capacitor and fan will deteriorate. Periodically replace these to prevent secondary damage from faults. Replacements can be made by our sales representative.
- Lock the control panel and prevent access to those who are not certified to handle or install electric equipment.
- Do not burn or break a module and servo amplifier. Doing so may cause a toxic gas.

(9) About processing of waste

When you discard Motion controller, servo amplifier, a battery (primary battery) and other option articles, please follow the law of each country (area).

 CAUTION

- This product is not designed or manufactured to be used in equipment or systems in situations that can affect or endanger human life.
- When considering this product for operation in special applications such as machinery or systems used in passenger transportation, medical, aerospace, atomic power, electric power, or submarine repeating applications, please contact your nearest Mitsubishi sales representative.
- Although this product was manufactured under conditions of strict quality control, you are strongly advised to install safety devices to forestall serious accidents when it is used in facilities where a breakdown in the product is likely to cause a serious accident.

(10) General cautions

- All drawings provided in the instruction manual show the state with the covers and safety partitions removed to explain detailed sections. When operating the product, always return the covers and partitions to the designated positions, and operate according to the instruction manual.

REVISIONS

* The manual number is given on the bottom left of the back cover.

Print Date	* Manual Number	Revision
Jun., 2005	IB(NA)-0300110-A	First edition
May., 2006	IB(NA)-0300110-B	[Additional model] Software for SV43 [Additional correction/partial correction] About Manuals, Troubleshooting
Sep., 2006	IB(NA)-0300110-C	[Additional model] Q61P, MR-J3-□B-RJ006 [Additional correction/partial correction] About Manuals
Dec., 2011	IB(NA)-0300110-D	[Partial correction] Safety Precautions, Section 4.2.1 Partial change of sentence, Warranty

Japanese Manual Number IB(NA)-0300090

This manual confers no industrial property rights or any rights of any other kind, nor does it confer any patent licenses. Mitsubishi Electric Corporation cannot be held responsible for any problems involving industrial property rights which may occur as a result of using the contents noted in this manual.

INTRODUCTION

Thank you for choosing the Q173HCPU/Q172HCPU Motion Controller.
Please read this manual carefully so that equipment is used to its optimum.

CONTENTS

Safety Precautions	A- 1
Revisions	A-11
Contents	A-12
About Manuals	A-15
1. OVERVIEW	1- 1 to 1- 2
1.1 Overview	1- 1
2. SYSTEM CONFIGURATION	2- 1 to 2-80
2.1 Motion System Configuration	2- 1
2.1.1 Q173HCPU System overall configuration	2- 3
2.1.2 Q172HCPU System overall configuration	2- 5
2.1.3 Function explanation of the Q173HCPU/Q172HCPU Motion CPU modules	2- 7
2.1.4 Restrictions on Motion systems	2- 9
2.2 System Configuration Equipment	2-11
2.3 General Specifications	2-18
2.4 Specifications of Equipment and Settings	2-20
2.4.1 Name of parts for CPU module	2-20
2.4.2 Power supply module	2-29
2.4.3 Base unit and extension cable	2-38
2.4.4 Q172LX Servo external signals interface module	2-41
2.4.5 Q172EX Serial absolute synchronous encoder interface module	2-46
2.4.6 Q173PX Manual pulse generator interface module	2-55
2.4.7 Manual pulse generator/Serial absolute synchronous encoder	2-64
2.4.8 A31TU-D3□/A31TU-DN□ Teaching unit (Japanese version only)	2-66
2.4.9 SSCNET III cables and connection method	2-74
2.4.10 External battery	2-79
3. DESIGN	3- 1 to 3-20
3.1 System Designing Procedure	3- 1
3.2 External Circuit Design	3- 4
3.2.1 Power supply circuit design	3-12
3.2.2 Safety circuit design	3-13
3.3 Layout Design within The Control Panel	3-15
3.3.1 Installation environment	3-15
3.3.2 Layout design of the base units	3-16
3.3.3 Calculating heat generation by Motion controller	3-17
3.4 Design Checklist	3-20

4. INSTALLATION AND WIRING	4- 1 to 4-22
-----------------------------------	---------------------

4.1 Module Installation	4- 1
4.1.1 Instructions for handling	4- 1
4.1.2 Instructions for installation of the base unit	4- 3
4.1.3 Installation and removal of module	4- 5
4.2 Installation and Removal of Cable.....	4- 7
4.2.1 SSCNETⅢ cable	4- 7
4.2.2 SSC I/F communication cable	4-10
4.2.3 Battery cable.....	4-11
4.2.4 Cable for teaching unit	4-12
4.3 Installation of the Serial Absolute Synchronous Encoder.....	4-14
4.4 Wiring.....	4-16
4.4.1 Instructions for wiring	4-16
4.4.2 Wiring to the power supply module	4-19
4.4.3 Precautions of SSCNETⅢ cable wiring	4-20
4.5 Installation/Wiring Checklist.....	4-22

5. TRIAL OPERATION AND ADJUSTMENT	5- 1 to 5- 8
--	---------------------

5.1 Checklist before Trial Operation	5- 1
5.2 Trial Operation and Adjustment Procedure.....	5- 2
5.3 Operating System Software Installation Procedure.....	5- 6
5.4 Trial Operation and Adjustment Checklist.....	5- 7

6. INSPECTION AND MAINTENANCE	6- 1 to 6-26
--------------------------------------	---------------------

6.1 Maintenance Works	6- 2
6.1.1 Instruction of Inspection works	6- 2
6.2 Daily Inspection	6- 4
6.3 Periodic Inspection.....	6- 5
6.4 External Battery.....	6- 6
6.4.1 Battery service life time	6- 7
6.4.2 Battery replacement procedure	6- 8
6.5 Discard of internal rechargeable battery	6-10
6.6 Troubleshooting	6-11
6.6.1 Basics of troubleshooting.....	6-11
6.6.2 Troubleshooting of Motion CPU module and I/O modules	6-12
6.6.3 I/O modules troubleshooting.....	6-23
6.7 Confirm method of Error Code	6-26

APPENDIX 1 Cables.....	App- 1
APPENDIX 1.1 SSCNET III cables.....	App- 1
APPENDIX 1.2 Serial absolute synchronous encoder cable.....	App- 5
APPENDIX 1.3 Cable for the teaching unit	App- 7
APPENDIX 1.4 Battery cable	App-13
APPENDIX 2 Exterior Dimensions	App-14
APPENDIX 2.1 CPU module	App-14
APPENDIX 2.2 Servo external signals interface module (Q172LX)	App-17
APPENDIX 2.3 Serial absolute synchronous encoder interface module (Q172EX-S2/Q172EX-S3).....	App-17
APPENDIX 2.4 Manual pulse generator interface module (Q173PX/Q173PX-S1).....	App-18
APPENDIX 2.5 Power supply module (Q61P-A1, Q61P-A2, Q62P, Q63P, Q64P)	App-19
APPENDIX 2.6 Battery holder unit (Q170HBATC)	App-20
APPENDIX 2.7 Connector	App-21
APPENDIX 2.8 Manual pulse generator (MR-HDP01)	App-26
APPENDIX 2.9 Serial absolute synchronous encoder (Q170ENC)	App-26
APPENDIX 2.10 Teaching unit (A31TU-D3□/A31TU-DN□)	App-27

About Manuals

The following manuals are related to this product.

Referring to this list, please request the necessary manuals.

Related Manuals

(1) Motion controller

Manual Name	Manual Number (Model Code)
Q173HCPU/Q172HCPU Motion controller Programming Manual (COMMON) This manual explains the Multiple CPU system configuration, performance specifications, common parameters, auxiliary/applied functions and others. (Optional)	IB-0300111 (1XB911)
Q173HCPU/Q172HCPU Motion controller (SV13/SV22) Programming Manual (Motion SFC) This manual explains the functions, programming, debugging, error codes and others of the Motion SFC. (Optional)	IB-0300112 (1XB912)
Q173HCPU/Q172HCPU Motion controller (SV13/SV22) Programming Manual (REAL MODE) This manual explains the servo parameters, positioning instructions, device list, error list and others. (Optional)	IB-0300113 (1XB913)
Q173HCPU/Q172HCPU Motion controller (SV22) Programming Manual (VIRTUAL MODE) This manual describes the dedicated instructions use to the synchronous control by virtual main shaft, mechanical system program create mechanical module. This manual explains the servo parameters, positioning instructions, device list, error list and others. (Optional)	IB-0300114 (1XB914)
Q173HCPU/Q172HCPU Motion controller (SV43) Programming Manual This manual describes the dedicated instructions to execute the positioning control by Motion program of EIA language (G-code). This manual explains the servo parameters, positioning instructions device list and error list and others. (Optional)	IB-0300115 (1XB915)

(2) PLC

Manual Name	Manual Number (Model Code)
<p>QCPU User's Manual (Hardware Design, Maintenance and Inspection)</p> <p>This manual explains the specifications of the QCPU modules, power supply modules, base modules, extension cables, memory card battery and others.</p> <p>(Optional)</p>	SH-080483ENG (13JR73)
<p>QCPU User's Manual (Function Explanation, Program Fundamentals)</p> <p>This manual explains the functions, programming methods and devices and others to create programs with the QCPU.</p> <p>(Optional)</p>	SH-080484ENG (13JR74)
<p>QCPU User's Manual (Multiple CPU System)</p> <p>This manual explains the functions, programming methods and cautions and others to construct the Multiple CPU system with the QCPU.</p> <p>(Optional)</p>	SH-080485ENG (13JR75)
<p>QCPU (Q Mode)/QnACPU Programming Manual (Common Instructions)</p> <p>This manual explains how to use the sequence instructions, basic instructions, application instructions and micro computer program.</p> <p>(Optional)</p>	SH-080039 (13JF58)
<p>QCPU (Q Mode)/QnACPU Programming Manual (PID Control Instructions)</p> <p>This manual explains the dedicated instructions used to exercise PID control.</p> <p>(Optional)</p>	SH-080040 (13JF59)
<p>QCPU (Q Mode)/QnACPU Programming Manual (SFC)</p> <p>This manual explains the system configuration, performance specifications, functions, programming, debugging, error codes and others of MELSAP3.</p> <p>(Optional)</p>	SH-080041 (13JF60)
<p>I/O Module Type Building Block User's Manual</p> <p>This manual explains the specifications of the I/O modules, connector, connector/terminal block conversion modules and others.</p> <p>(Optional)</p>	SH-080042 (13JL99)

(3) Servo amplifier

Manual Name	Manual Number (Model Code)
<p>MR-J3-□B Servo amplifier Instruction Manual</p> <p>This manual explains the I/O signals, parts names, parameters, start-up procedure and others for MR-J3-□B Servo amplifier.</p> <p>(Optional)</p>	SH-030051 (1CW202)
<p>Fully Closed Loop Control MR-J3-□B-RJ006 Servo amplifier Instruction Manual</p> <p>This manual explains the I/O signals, parts names, parameters, start-up procedure and others for Fully Closed Loop Control MR-J3-□B-RJ006 Servo amplifier.</p> <p>(Optional)</p>	SH-030056 (1CW304)

1. OVERVIEW

1.1 Overview

This User's Manual describes the hardware specifications and handling methods of the Motion Controller's Model Q173HCPU/Q172HCPU for the Q series PLC Multiple CPU system.

The Manual also describes those items related to the specifications of the option module for the Motion controller, Manual pulse generator, Synchronous encoder, Teaching unit and cables.

In this manual, the following abbreviations are used.

Generic term/Abbreviation	Description
Q173HCPU/Q172HCPU or Motion CPU (module)	Q173HCPU/Q172HCPU/Q173HCPU-T/Q172HCPU-T Motion CPU module
Q172LX/Q172EX/Q173PX or Motion module	Q172LX Servo external signals interface module/ Q172EX-S2/-S3 Serial absolute synchronous encoder interface module ^(Note-1) / Q173PX(-S1) Manual pulse generator interface module
MR-J3-□B	Servo amplifier model MR-J3-□B
AMP or Servo amplifier	General name for "Servo amplifier model MR-J3-□B"
QCPU, PLC CPU or PLC CPU module	Qn(H)CPU
Multiple CPU system or Motion system	Abbreviation for Multiple PLC system of the Q series
CPU _n	Abbreviation for "CPU No.n (n= 1 to 4) of the CPU module for the Multiple CPU system"
Programming software package	General name for "MT Developer" and "GX Developer"
Operating system software	General name for "SW□RN-SV□Q□"
SV13	Operating system software for conveyor assembly use (Motion SFC) : SW6RN-SV13Q□
SV22	Operating system software for automatic machinery use (Motion SFC) : SW6RN-SV22Q□
SV43	Operating system software for machine tool peripheral use: SW5RN-SV43Q□
MT Developer	Abbreviation for Integrated start-up support software package "MT Developer (Version□ ^(Note-2) or later)"
GX Developer	Abbreviation for MELSEC PLC programming software package "GX Developer (Version 6 or later)"
Manual pulse generator or MR-HDP01	Abbreviation for "Manual pulse generator (MR-HDP01)"
Serial absolute synchronous encoder or Q170ENC	Abbreviation for "Serial absolute synchronous encoder (Q170ENC)"
SSCNET ^{III} ^(Note-3)	High speed synchronous network between Motion controller and servo amplifier
SSCNET ^(Note-3)	High speed synchronous communication network between Motion controller and servo amplifier
Absolute position system	General name for "System using the servomotor and servo amplifier for absolute position"
Battery holder unit	Battery holder unit (Q170HBATC)
External battery	General name for "Q170HBATC" and "Q6BAT"

1 OVERVIEW

Generic term/Abbreviation	Description
A□0BD-PCF	A10BD-PCF/A30BD-PCF SSC I/F board
SSC I/F communication cable	Abbreviation for "Cable for SSC I/F board/card"
Teaching unit or A31TU-D3□/A31TU-DN□	A31TU-D3□/A31TU-DN□ Teaching unit ^(Note-4)
Intelligent function module	Abbreviation for "MELSECNET/H module/Ethernet module/CC-Link module/ Serial communication module"

(Note-1) : Q172EX can be used in SV22.

(Note-2) : Refer to Section "2.2 (4) Software packages" for the correspondence version.

(Note-3) : SSCNET: Servo System Controller NETwork

(Note-4) : Teaching unit can be used in SV13.

REMARK

For information about the each module, design method for program and parameter, refer to the following manuals relevant to each module.

Item	Reference Manual
PLC CPU, peripheral devices for PLC program design, I/O modules and intelligent function module	Manual relevant to each module
Operation method for MT Developer	Help of each software
SV13/SV22/ SV43	<ul style="list-style-type: none"> • Multiple CPU system configuration • Performance specification • Design method for common parameter • Auxiliary and applied functions (common) Q173HCPU/Q172HCPU Motion controller Programming Manual (COMMON)
SV13/SV22	<ul style="list-style-type: none"> • Design method for Motion SFC program • Design method for Motion SFC parameter • Motion dedicated PLC instruction Q173HCPU/Q172HCPU Motion controller (SV13/SV22) Programming Manual (Motion SFC)
	<ul style="list-style-type: none"> • Design method for positioning control program in the real mode • Design method for positioning control parameter Q173HCPU/Q172HCPU Motion controller (SV13/SV22) Programming Manual (REAL MODE)
SV22 (Virtual mode)	<ul style="list-style-type: none"> • Design method for mechanical system program Q173HCPU/Q172HCPU Motion controller (SV22) Programming Manual (VIRTUAL MODE)
SV43	<ul style="list-style-type: none"> • Design method for Motion program • Motion dedicated PLC instruction • Design method for positioning control parameter Q173HCPU/Q172HCPU Motion controller (SV43) Programming Manual

2. SYSTEM CONFIGURATION

This section describes the Q173HCPU/Q172HCPU system configuration, precautions on use of system and configured equipments.

2.1 Motion System Configuration

(1) Equipment configuration in Q173HCPU/Q172HCPU system

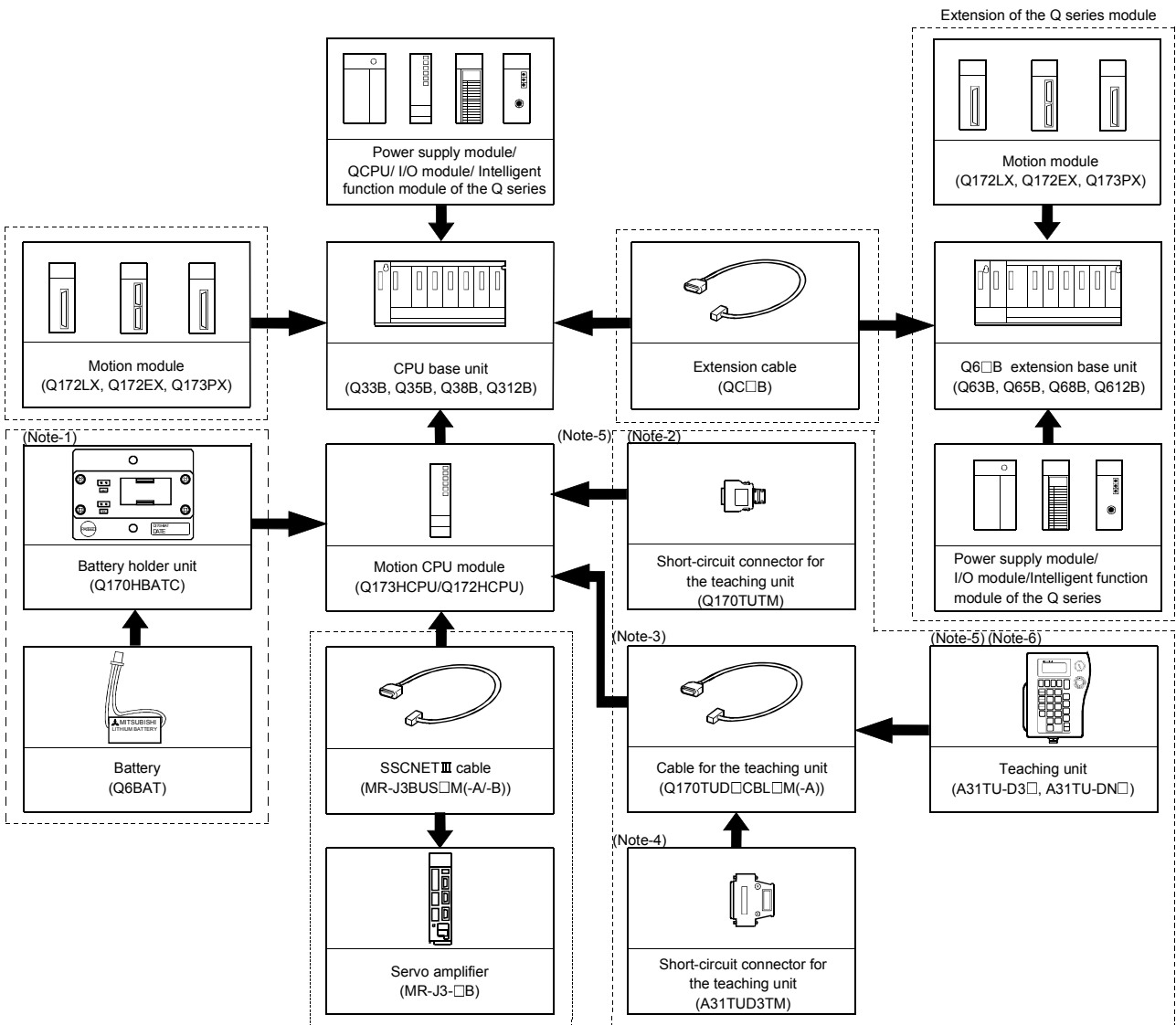

It is possible to select the best according to the system.

(Note-1) : When using the external battery, be sure to connect the Battery holder unit (Q170HBATC). And be sure to set the Battery(Q6BAT) to the Battery holder unit (Q170HBATC). Battery(Q6BAT) is optional.

(Note-2) : It is possible to use only Q173HCPU-T/Q172HCPU-T. It is packed together with Q173HCPU-T/Q172HCPU-T.

(Note-3) : It varies by the connecting teaching unit.

(Note-4) : It is packed together with Q170TUD□CBL□M.

(Note-5) : When using the A31TU-D3□/A31TU-DN□, be sure to use the Q173HCPU-T/Q172HCPU-T.

(Note-6) : A31TU-D3□/A31TU-DN□ corresponds to only Japanese. It does not correspond to display for English.

(2) Peripheral device configuration for the Q173HCPU/Q172HCPU
 The following (a)(b) can be used.

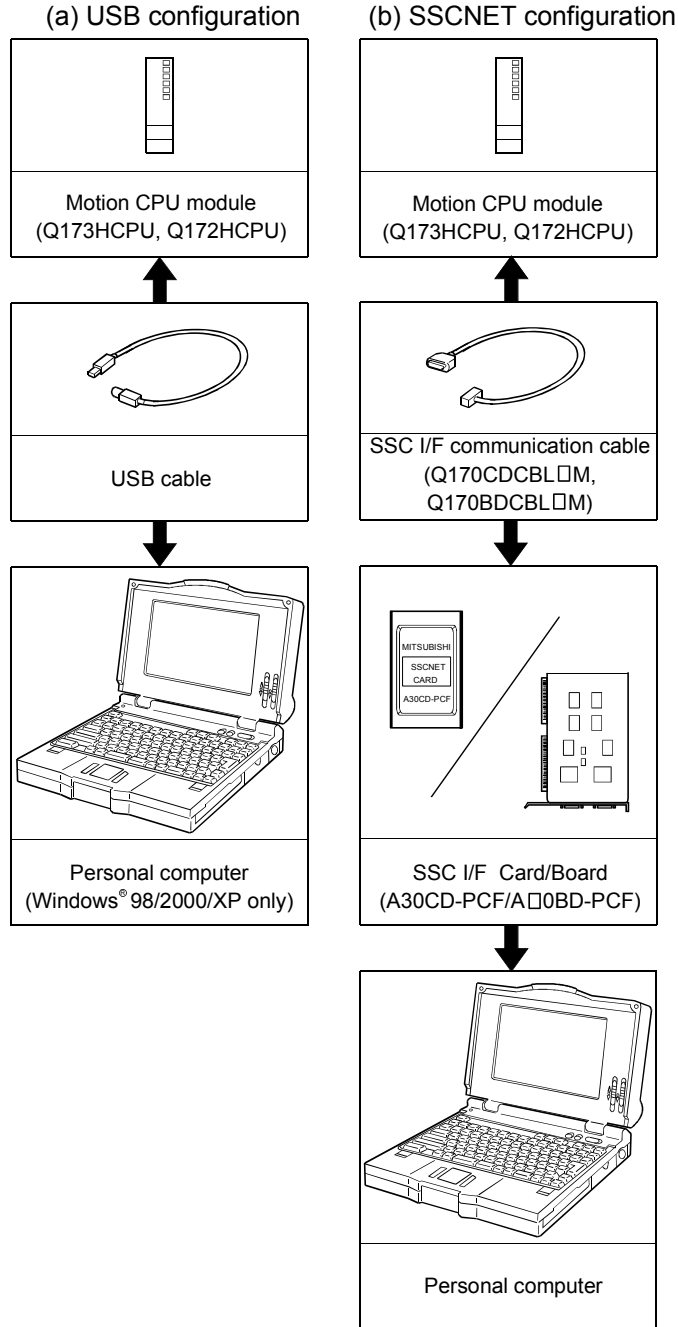

(Note) : For information about GPP functions of PLC CPU, refer to the operating manual of PLC. Also, refer to the programming manual of the operating system for information about creating Motion programs, and refer to the help of each software for information about operation of each programming software package.

2 SYSTEM CONFIGURATION

2.1.1 Q173HCPU System overall configuration

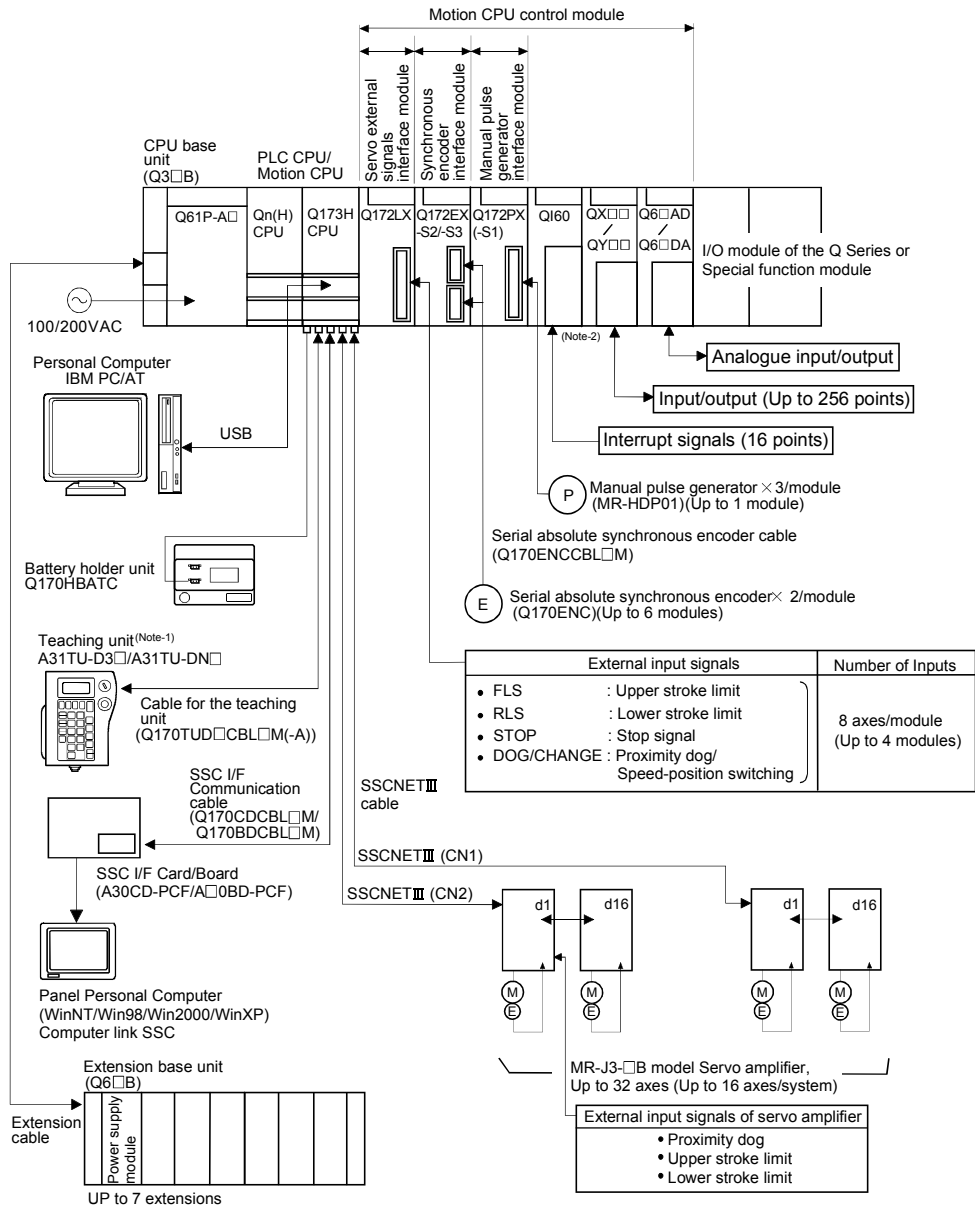

(Note-1) : Be sure to use the Q173HCPU-T.
A31TU-D3□ /A31TU-DN□ corresponds to only Japanese.
It does not correspond to display for English.

(Note-2) : QI60 can be used in SV13/SV22.

CAUTION

- Construct a safety circuit externally of the Motion controller or servo amplifier if the abnormal operation of the Motion controller or servo amplifier differ from the safety directive operation in the system.
- The ratings and characteristics of the parts (other than Motion controller, servo amplifier and servomotor) used in a system must be compatible with the Motion controller, servo amplifier and servomotor.
- Set the parameter values to those that are compatible with the Motion controller, servo amplifier, servomotor and regenerative resistor model and the system application. The protective functions may not function if the settings are incorrect.
- When a teaching unit is used, the cable for the teaching unit is necessary between the Motion CPU (Q173HCPU-T/Q172HCPU-T) and teaching unit. And, connect the short-circuit connector for teaching unit, after removing the teaching unit or when not using it.

2 SYSTEM CONFIGURATION

2.1.2 Q172HCPU System overall configuration

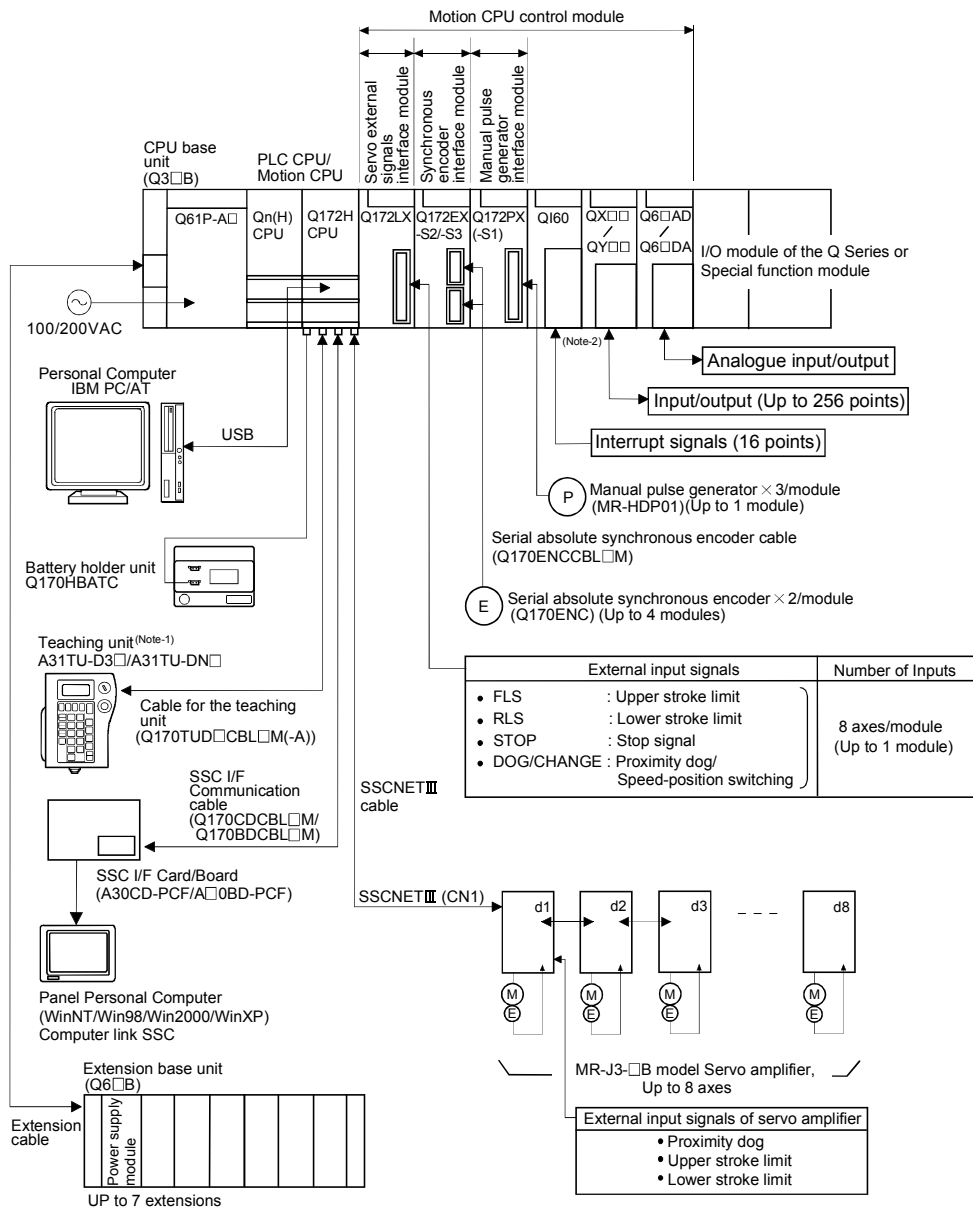

(Note-1) : Be sure to use the Q173HCPU-T.
A31TU-D3□/A31TU-DN□ corresponds to only Japanese.
It does not correspond to display for English.

(Note-2) : QI60 can be used in SV13/SV22.

CAUTION

- Construct a safety circuit externally of the Motion controller or servo amplifier if the abnormal operation of the Motion controller or servo amplifier differ from the safety directive operation in the system.
- The ratings and characteristics of the parts (other than Motion controller, servo amplifier and servomotor) used in a system must be compatible with the Motion controller, servo amplifier and servomotor.
- Set the parameter values to those that are compatible with the Motion controller, servo amplifier, servomotor and regenerative resistor model and the system application. The protective functions may not function if the settings are incorrect.
- When a teaching unit is used, the cable for the teaching unit is necessary between the Motion CPU (Q173HCPU-T/Q172HCPU-T) and teaching unit. And, connect the short-circuit connector for teaching unit, after removing the teaching unit or when not using it.

2.1.3 Function explanation of the Q173HCPU/Q172HCPU Motion CPU modules

- (1) Up to 32 axes servo amplifiers per 2 systems (up to 16 axes per 1 system) can be used in Q173HCPU. Up to 8 axes servo amplifiers per 1 system can be used in Q172HCPU.
- (2) It is possible to set the program which synchronized with the motion operation cycle and executed at fixed cycle (0.88[ms], 1.77[ms], 3.55[ms], 7.11[ms], 14.2[ms]).
- (3) It is possible to execute a download of servo parameters to servo amplifier, servo ON/OFF to servo amplifier and position commands, etc. by connecting between the Q173HCPU/Q172HCPU and servo amplifier with SSCNETⅢ cable.
- (4) It is possible to select the servo control functions/programming languages by installing the corresponding operating system software in the Q173HCPU/Q172HCPU.
- (5) It is possible to use the signals such as stroke limit signals and synchronous encoder connected to various Motion modules for motion control by setting the Q173HCPU/Q172HCPU as the control CPU of various motion modules (Q172LX/Q172EX, etc.).
- (6) It is possible to execute not only servo control but also DI/O input/output control according to programs described in Motion SFC program by setting the Q173HCPU/Q172HCPU as the control CPU of Q series PLC I/O modules (When the Motion SFC is used as the operating system software.).
(Refer to Section 2.2 (2) for Q series PLC I/O modules that can be controlled by Motion CPU.)
- (7) It is possible to exchange a data among CPUs such as automatic refresh, as the Q series PLC Multiple CPU system.
- (8) There is no restriction for installation position of Q172LX/Q173PX among modules controlled by Motion CPU. The installation position of Q172EX is only CPU base unit.
Set the installation position in the system settings.
- (9) It is possible to change a servo program, monitor or execute JOG operation by connecting the teaching unit (A31TU-D3□/A31TU-DN□).
(Q173HCPU-T/Q172HCPU-T only).
- (10) It is possible to execute the synchronous control corresponding to resolution (262144[PLS/rev]) of servo amplifier (MR-J3-□B) by connecting the serial absolute synchronous encoder (Q170ENC) to Q172EX.

2 SYSTEM CONFIGURATION

- (11) The maximum distance between the Motion CPU and servo amplifier, servo amplifier and servo amplifier of the SSCNET III cable on the same bus was set to 50(164.04)[m(ft.)], and the flexibility improved at the Motion system design.
- (12) Motion CPU becomes difficult to be influenced of an electromagnetic noise from servo amplifier, etc. by using the SSCNET III cable (optical communication).

2 SYSTEM CONFIGURATION

2.1.4 Restrictions on Motion systems

- (1) It is not allowed to use the Motion CPU as the control CPU of a module installed on the QA1S6□B extension base unit. PLC CPU must be used as the control CPU.
- (2) Motion CPU module cannot be used as standalone module. It must always be used in combination with the PLC CPU module (version that supports Multiple CPU systems). Moreover, it must be installed on the right side of PLC CPU module. PLC CPU module cannot be installed in a position to the right of Motion CPU module.
- (3) Personal computer CPU unit must be installed on the right side of Motion CPU module. Motion CPU module cannot be installed in a position to the right of personal computer CPU unit.
- (4) Make sure to use the PLC CPU module in "Q mode".
- (5) Motion CPU module cannot be set as the control CPU of intelligent function module or Graphic Operation Terminal (GOT).
- (6) SSCNETⅢ cable which connects the Motion CPU and servo amplifier, and the teaching unit connecting cable which connects the Motion CPU and A31TU-D3□/A31TU-DN□^(Note-1) are pulled from the bottom part of unit. Make sure to secure sufficient space for pulling out the cable when designing the control panel.
- (7) Motion CPU module is one module element of Q series multiple PLC system. It must be set the parameters of Q series multiple PLC system for each PLC CPU. Motion CPU module must also be set to support the Multiple CPU system in the system settings.
- (8) Make sure to use the Motion CPU as the control CPU of motion modules dedicated for Motion CPU (Q172LX, Q172EX^(Note-2), Q173PX, etc.). They will not operate correctly if PLC CPU is set and installed as the control CPU by mistake. Motion CPU is treated as a 32-point intelligent module by PLC CPU of other CPU. It cannot be accessed from other CPU.
- (9) When a Multiple CPU system is configured, make sure to configure the modules so that the total current consumption of individual modules on the CPU base does not exceed the 5VDC output capacity of power supply module.
(Refer to Section 2.4.2 (3), (4) "Selection of the power supply module".)
- (10) Installation position of the Q172EX^(Note-2) is only CPU base unit.

(Note-1) : Teaching unit can be used in SV13. It cannot be used in SV22/SV43.

(Note-2) : Q172EX can be used in SV22. It cannot be used in SV13/SV43.

2 SYSTEM CONFIGURATION

- (11) When combining the Q173HCPU(-T)/Q172HCPU(-T) with Q173CPU(N)/Q172CPU(N)/Q173CPUN-T/Q172CPUN-T, set as following combination. If it is used in combination except for the following, the Q173HCPU(-T)/Q172HCPU(-T) does not operate normally, such as Q173HCPU(-T)/Q172HCPU(-T) does not start or communication error with servo amplifier will occur.

However, all the operating system software are SV43, there is no restriction for the combination of Motion CPU.

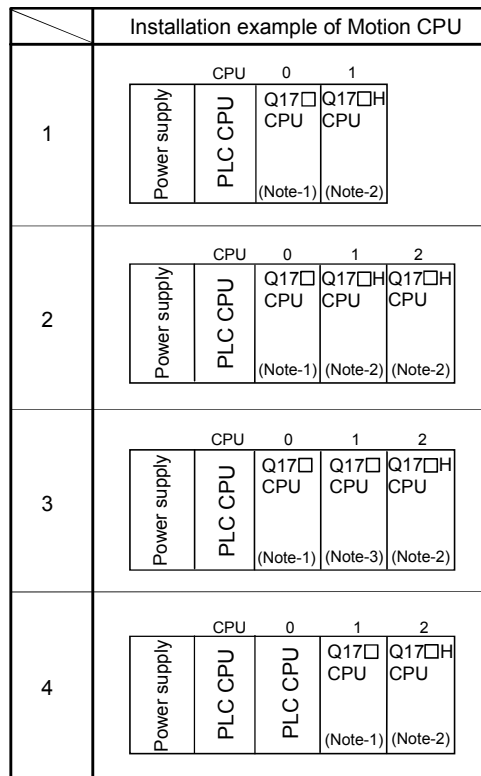

Abbreviation	Model name
Q17□H CPU	Q17□H CPU(-T)
Q17□ CPU	Q17□ CPU(N)/Q17□ CPUN(-T)

(Note-1): Be sure to install the following operating system software to the Q17□ CPU.

Application	Version
SV13/SV22	00R or later

(Note-2): There is no restriction for the operating system software and version installed to the Q17□H CPU.

(Note-3): There is no restriction for the operating system software and version installed to the Q17□ CPU.

- (12) When the operation cycle is 0.4[ms], set the system setting as the axis select switch of servo amplifier "0 to 7".
If the axis select switch of servo amplifier "8 to F" is set, the servo amplifiers are not recognized.
- (13) The backup time (when it is charged for 40 hours) for internal rechargeable battery of Motion CPU is 1100 hours (Guaranteed time)/4300 hours (Actual time).
Set the external battery if the power failure time exceeds guaranteed time.
(Refer to Section 2.4.10 External battery)

Item		Continuous power failure time [h]	
		Guaranteed time (MIN)	Actual time (TYP)
Internal rechargeable battery ^(Note)	Charging time: 8 hours or more	200	500
	Charging time: 40 hours or more	1100	4300
External battery		60000	240000

(Note): Internal rechargeable battery is charged while power ON.

2 SYSTEM CONFIGURATION

2.2 System Configuration Equipment

(1) Table of Motion controller related module

Part name	Model name ^(Note-1)	Description	Current consumption 5VDC[A]	Remark
Motion CPU module	Q173HCPU	Up to 32 axes control, Operation cycle 0.4[ms] or more	1.25	
	Q173HCPU-T	Up to 32 axes control, Operation cycle 0.4[ms] or more, For teaching unit	1.56	
	Q172HCPU	Up to 8 axes control, Operation cycle 0.4[ms] or more	1.14	
	Q172HCPU-T	Up to 8 axes control, Operation cycle 0.4[ms] or more, For teaching unit	1.45	
Servo external signals interface module	Q172LX	Servo external signal input 8 axes (FLS, RLS, STOP, DOG/CHANGE×8)	0.05	
Serial absolute synchronous encoder interface module	Q172EX-S2	Serial absolute synchronous encoder Q170ENC interface×2, Tracking input 2 points	0.07	
	Q172EX-S3 ^(Note-2)	Serial absolute synchronous encoder Q170ENC interface×2, Tracking input 2 points, Memory built-in for data exchange		
Manual pulse generator interface module	Q173PX	Manual pulse generator MR-HDP01/Incremental synchronous encoder interface ×3, Tracking input 3 points	0.11	
	Q173PX-S1 ^(Note-2)	Manual pulse generator MR-HDP01/Incremental synchronous encoder interface ×3, Tracking input 3 points, Memory built-in for data exchange		
PLC CPU module	Q00CPU	Program capacity 8k steps	0.25	
	Q01CPU	Program capacity 14k steps	0.27	
	Q02CPU	Program capacity 28k steps	0.60	
	Q02HCPU	Program capacity 28k steps	0.64	
	Q06HCPU	Program capacity 60k steps		
	Q12HCPU	Program capacity 124k steps		
	Q25HCPU	Program capacity 252k steps		
Power supply module ^(Note-3)	Q61P-A1	100 to 120VAC input, 5VDC 6A output	—	
	Q61P-A2	200 to 240VAC input, 5VDC 6A output		
	Q61P	100 to 240VAC input, 5VDC 6A output		
	Q62P	100 to 240VAC input, 5VDC 3A/24VDC 0.6A output		
	Q63P	24VDC input, 5VDC 6A output		
	Q64P	100 to 120VAC/200 to 240VAC input, 5VDC 8.5A output		
CPU base unit	Q33B	Number of I/O modules installed 3 slots	0.105	
	Q35B	Number of I/O modules installed 5 slots	0.110	
	Q38B	Number of I/O modules installed 8 slots	0.114	
	Q312B	Number of I/O modules installed 12 slots	0.121	
Extension base unit	Q63B	Number of I/O modules installed 3 slots	0.105	
	Q65B	Number of I/O modules installed 5 slots	0.110	
	Q68B	Number of I/O modules installed 8 slots	0.114	
	Q612B	Number of I/O modules installed 12 slots	0.121	
Extension cable	QC05B	Length 0.45m(1.48ft.)	—	
	QC06B	Length 0.6m(1.97ft.)		
	QC12B	Length 1.2m(3.94ft.)		
	QC30B	Length 3m(9.84ft.)		
	QC50B	Length 5m(16.40ft.)		
	QC100B	Length 10m(32.81ft.)		

2 SYSTEM CONFIGURATION

Table of Motion controller related module(continued)

Part name	Model name ^(Note-1)	Description	Current consumption 5VDC[A]	Remark
Serial absolute synchronous encoder	Q170ENC	Resolution: 262144PLS/rev Permitted axial loads Radial load: Up to 19.6N Thrust load: Up to 9.8N Permitted speed: 3600r/min	0.20	
Serial absolute synchronous encoder cable	Q170ENC CBL□M	Serial absolute synchronous encoder Q170ENC ↔ Q172EX-S2/-S3 2m(6.56ft.), 5m(16.40ft.), 10m(32.81ft.), 20m(65.62ft.), 30m(98.43ft.), 50m(164.04ft.)	—	
Connector set for serial absolute synchronous encoder cable	Q170ENC CNS	Q172EX-S2/-S3 side connector Connector :10120-3000VE Connector case : 10320-52F0-008 Q170ENC side connector Plug : MS3106B22-14S Cable clamp : MS3057-12A	—	
Manual pulse generator	MR-HDP01	Pulse resolution: 25PLS/rev(100PLS/rev after magnification by 4) Permitted axial loads Radial load: Up to 19.6N Thrust load: Up to 9.8N Permitted speed: 200r/min(Normal rotation), Voltage output	0.06	
Battery holder unit ^(Note-4)	Q170HBATC	Battery holder for Q6BAT (Attachment battery cable)	—	
Battery	Q6BAT	For IC-RAM memory backup of Q173HCPU/Q172HCPU module (Motion SFC programs (SV13/SV22), Servo programs (SV13/SV22), Motion programs (SV43), Parameters)	—	
	A6BAT	For backup of Q170ENC	—	
Teaching unit	A31TU-D3K13	For SV13, With 3-position deadman switch, Only Japanese	0.26	
	A31TU-DNK13	For SV13, Without deadman switch, Only Japanese		
Cable for the teaching unit	Q170TUD3CBL3M	Q173HCPU-T/Q172HCPU-T ↔ A31TU-D3□, 3m(9.84ft.) (Attachment: Short-circuit connector (A31TUD3TM) for teaching unit)	—	
	Q170TUDNCBL3M	Q173HCPU-T/Q172HCPU-T ↔ A31TU-DN□, 3m(9.84ft.) (Attachment: Short-circuit connector (A31TUD3TM) for teaching unit)	—	
	Q170TUDNCBL03M-A	Exchange cable for direct connection of Q173HCPU-T/Q172HCPU-T ↔ A31TU-DN□, 0.3m(0.98ft.)	—	
Short-circuit connector for teaching unit	Q170TUTM	Short-circuit connector for teaching unit for direct connection to Q173HCPU-T/Q172HCPU-T It is packed together with Q173HCPU-T/Q172HCPU-T.	—	
	A31TUD3TM	Short-circuit connector for teaching unit for connection to Q170TUD3CBL3M/Q170TUDNCBL3M. It is packed together with Q170TUD3CBL3M/Q170TUDNCBL3M.	—	
SSC I/F board	A10BD-PCF	PCI bus loading type, 2ch/board	0.50	
	A30BD-PCF	ISA bus loading type, 2ch/board	0.83	
SSC I/F card	A30CD-PCF	PCMCIA TYPEII, 1ch/card	0.24	
Cable for SSC I/F board	Q170BDCBL□M	Q173HCPU/Q172HCPU ↔ SSC I/F board 3m(9.84ft.), 5m(16.40ft.), 10m(32.81ft.)	—	
Cable for SSC I/F card	Q170CDCBL□M	Q173HCPU/Q172HCPU ↔ SSC I/F card 3m(9.84ft.), 5m(16.40ft.), 10m(32.81ft.)		

2 SYSTEM CONFIGURATION

Table of Motion controller related module(continued)

Part name	Model name ^(Note-1)	Description	Current consumption 5VDC[A]	Remark
Connector/terminal block conversion module	A6TBXY36	For positive common sink type input module, sink type output module (standard type)	—	
	A6TBXY54	For positive common sink type input module, sink type output module (2-wire type)	—	
	A6TBX70	For positive common sink type input module (3-wire type)	—	
Cable for connector/terminal block conversion module	AC05TB	Length 0.5m (1.64ft.)	—	
	AC10TB	Length 1m (3.28ft.)	—	
	AC20TB	Length 2m (6.56ft.)	—	
	AC30TB	Length 3m (9.84ft.)	—	
	AC50TB	Length 5m (16.40ft.)	—	
	AC80TB	Length 8m (26.25ft.)	—	
	AC100TB	Length 10m(32.81ft.)	—	
SSCNETⅢ cable	MR-J3BUS□M	<ul style="list-style-type: none"> • Q173HCPU/Q172HCPU ↔ MR-J3-□B • MR-J3-□B ↔ MR-J3-□B • Standard code for inside panel • 0.15m(0.49ft.), 0.3m(0.98ft.), 0.5m(1.64ft.), 1m(3.28ft.), 3m(9.84ft.) 	—	
	MR-J3BUS□M-A	<ul style="list-style-type: none"> • Q173HCPU/Q172HCPU ↔ MR-J3-□B • MR-J3-□B ↔ MR-J3-□B • Standard cable for outside panel • 5m(16.40ft.), 10m(32.81ft.), 20m(65.62ft.) 	—	
	MR-J3BUS□M-B ^(Note-5)	<ul style="list-style-type: none"> • Q173HCPU/Q172HCPU ↔ MR-J3-□B • MR-J3-□B ↔ MR-J3-□B • Long distance cable • 30m(98.43ft.), 40m(131.23ft.), 50m(164.04ft.) 	—	

(Note-1) : □=Cable length (015: 0.15m(0.49ft.), 03: 0.3m(0.98ft.), 05: 0.5m(1.64ft.), 1: 1m(3.28ft.), 2: 2m(6.56ft.), 3: 3m(9.84ft.), 5: 5m(16.40ft.), 10: 10m(32.81ft.), 20: 20m(65.62ft.), 30: 30m(98.43ft.), 40: 40m(131.23ft.), 50:50m(164.04ft.)

(Note-2) : Q172EX-S3 and Q173PX-S1 can be used in only the operating system software of special specification that needs data exchange function.

(Note-3) : Be sure to use the power supply module within the range of power supply capacity.

(Note-4) : Battery Q6BAT is not attached to Battery holder unit Q170HBATC. Please purchase it separately.

(Note-5) : Please contact your nearest Mitsubishi sales representative for the cable of less than 30m(98.43ft.).

2 SYSTEM CONFIGURATION

(2) Q series PLC module which can be control by Motion CPU

Part name		Model name	Description	Remark	
Input module	AC	QX10	100-120VAC, 7-8mA, 16 points, Terminal block		
	DC	QX40	24VDC/4mA, Positive common, 16 points, Terminal block		
		QX41	24VDC/4mA, Positive common, 32 points, Connector	*	
		QX42	24VDC/4mA, Positive common, 64 points, Connector	*	
		QX70	12VDC/5V, Positive common/Negative common shared, 16 points, Terminal block		
		QX71	12VDC/5V, Positive common/Negative common shared, 32 points, Terminal block		
		QX72	12VDC/5V, Positive common/Negative common shared, 64 points, Terminal block		
		QX80	24VDC/4mA, Negative common, 16 points, Terminal block		
		QX81	24VDC/4mA, Negative common, 32 points, Connector	*	
Output module	Contact output module	QY10	240VAC/24VDC, 2A/point, 8A/common, 16 points/common, Terminal block		
	Transistor	Sink Type	QY40P	12V/24VDC, 0.1A/point, 1.6A/common, 16 points/common Terminal block	
			QY41P	12V/24VDC, 0.1A/point, 2A/common, 32 points/common Connector	*
			QY42P	12V/24VDC, 0.1A/point, 2A/common, 64 points(32 points/common), Connector	*
			QY50	12V/24VDC, 0.5A/point, 4A/common, 16 points(16 points/common), Terminal block	
	Source Type	QY80	12V/24VDC, 0.5A/point, 4A/common, 16 points(16 points/common), Terminal block		
		QY81P	12V/24VDC, 0.1A/point, 2A/common, 32 points(32 points/common), Connector	*	
	TTL•CMOS(Sink)	QY70	5/12VDC, 16mA/point, 16 points(16 points/common), Terminal block		
		QY71	5/12VDC, 16mA/point, 32 points(32 points/common), Connector	*	
Input/Output composite module	DC Input/ Transistor output	QH42P	24VDC Positive common: 32 points DC12-24V/0.1A Output Sink type: 32 points, Connector, Provided (Thermal protectors, protector against short circuit)	*	
		QX48Y57	24VDC Positive common: 8 points DC12-24V/0.5A Output Sink type: 7 points, Terminal block, Provided (When face is broken, LED lights and signal is output to CPU)		
Interrupt module		QI60	DC24V/4mA, Positive common, 16 points, Terminal block		
Analogue module		Q64AD	4ch, A/D conversion, Voltage • Current input		
		Q68ADV	8ch, A/D conversion, Voltage input		
		Q68ADI	8ch, A/D conversion, Current input		
		Q62DA	2ch, D/A conversion, Voltage • Current output		
		Q64DA	4ch, D/A conversion, Voltage • Current output		
		Q68DAV	8ch, D/A conversion, Voltage output		
		Q68DAI	8ch, D/A conversion, Current output		

Marked "*" : connectors are not provided.

2 SYSTEM CONFIGURATION

(3) Table of servo amplifier

Part name	Model name	Description
MR-J3 series servo amplifier	MR-J3-□B MR-J3-□B-RJ006	Refer to catalogue of the servo amplifier.
Battery	MR-J3BAT	

(4) Software packages

(a) Operating system software packages

Application	Software package	
	Q173HCPU	Q172HCPU
For conveyor assembly SV13 (Motion SFC)	SW6RN-SV13QK	SW6RN-SV13QM
For automatic machinery SV22 (Motion SFC)	SW6RN-SV22QJ	SW6RN-SV22QL
For machine tool peripheral SV43	SW5RN-SV43QJ	SW5RN-SV43QL

(b) Integrated start-up support software package

Part name	Model name	Details	Version			
MT Developer	SW6RNC- GSVPROE	SW6RNC-GSVE (Integrated start-up support software (1 CD-ROM))	00K	00M	00N	
		Conveyor assembly software : SW6RN-GSV13P	00J	00K	00L	
		Automatic machinery software : SW6RN-GSV22P	00J	00K	00L	
		Machine tool peripheral software : SW6RN-GSV43P	—	00F	00G	
		Cam data creation software : SW3RN-CAMP	00M	00M	00M	
		Digital oscilloscope software : SW6RN-DOSCP	00G	00H	00H	
		Communication system software : SW6RN-SNETP	00J	00K	00L	
	Document print software : SW3RN-DOCPRNP, SW20RN-DOCPRNP	00R 00M	00T 00Q	00W 00T		
	SW6RNC-GSVHELPE (Operation manual (1 CD-ROM))					
	Installation manual					
	SW6RNC- GSVSETE	SW6RNC-GSVPROE				
		A30CD-PCF(SSC I/F card (PCMCIA TYPE II 1CH/card))				
		Q170CDCBL3M (A30CD-PCF cable 3m (9.84ft.))				

(Note) : Operating environment of the MT Developer is WindowsNT[®] 4.0/Windows[®] 98/Windows[®] 2000/Windows[®] XP English version only.

2 SYSTEM CONFIGURATION

(5) Operating environment of personal computer

Operating environment is shown below.

IBM PC/AT with which WindowsNT[®] 4.0/ Windows[®] 98/ Windows[®] 2000/Windows[®] XP English version operates normally.

Item	WindowsNT [®] 4.0 (Service Pack 2 or later)(Note) or Windows [®] 98	Windows [®] 2000	Windows [®] XP
CPU	Pentium [®] 133MHz or more	Pentium [®] II 233MHz or more	Pentium [®] II 450MHz or more
Memory capacity	Recommended 32MB or more	Recommended 64MB or more	Recommended 192MB or more
Hard disk free space	Hard disk free space is as following list.		
Disk drive	3.5inch (1.44MB) floppy disk drive, CD-ROM disk drive		
Display	800×600 pixels, 256 colors or more		

(Note) : Impossible to use USB connection.

It is necessary the following capacity depending on the installed software.

Model name	Size		
	SW6RNC-GSVE	SW6RNC-GSVHELPE	
SW6RN-GSV13P	65MB	40MB	
SW6RN-GSV22P	66MB	45MB	
SW6RN-GSV43P	55MB	32MB	
SW3RN-CAMP	5MB	3MB	
SW6RN-DOSCP	35MB	10MB	
SW6RN-SNETP	Standard	60MB	3MB
	Custom (When all selection)	60.5MB	
SW3RN-DOCPRNP	45MB	5MB	
SW20RN-DOCPRNP	45MB	5MB	

(Note-1) : WindowsNT[®] , Windows[®] are either registered trademarks or trademarks of Microsoft Corporation in the United States and/or other countries.

(Note-2) : Pentium[®] are trademarks or registered trademarks of Intel Corporation or its subsidiaries in the United States and other countries.

2 SYSTEM CONFIGURATION

(6) Related software packages

(a) PLC software package

Model name	Software package
GX Developer	SW□D5C-GPPW-E

(Note) : □=used "6" or later.

(b) Servo set up software package

Model name	Software package
MR Configurator	MRZJW3-SETUP221E

POINTS

- (1) When the operation of Windows is not unclear in the operation of this software, refer to the manual of Windows or guide-book from the other supplier.
- (2) The screen might not be correctly displayed depending on the system font size of WindowsNT[®] 4.0/Windows[®] 98/Windows[®] 2000/ Windows[®] XP.
Be sure to use the small size fonts.

2 SYSTEM CONFIGURATION

2.3 General Specifications

General specifications of Q173HCPU/Q172HCPU module are shown below.

Item	Specification					
Operating ambient temperature	0 to 55°C (32 to 131°F)					
Storage ambient temperature	-25 to 75°C (Note-3) (-13 to 167°F)					
Operating ambient humidity	5 to 95% RH, non-condensing					
Storage ambient humidity	5 to 95% RH, non-condensing					
Vibration resistance	Conforming JIS B 3502, IEC 61131-2		Frequency	Acceleration	Amplitude	Sweep count
		Under intermittent vibration	5 to 9Hz	—	3.5mm (0.14inch)	10 times each in X, Y, Z directions (For 80 min.)
			9 to 150Hz	9.8m/s ²	—	
		Under continuous vibration	5 to 9Hz	—	1.75mm (0.07inch)	
9 to 150Hz	4.9m/s ²		—			
Shock resistance	Conforming to JIS B 3502, IEC 61131-2(147m/s ² , 3 times in each of 3 directions X, Y, Z)					
Operating ambience	No corrosive gases					
Operating altitude	2000m(6561.68ft.) or less					
Installation location	Inside control panel					
Overvoltage category (Note-1)	II or less					
Pollution level (Note-2)	2 or less					
Noise immunity	(1) By noise simulator of 1,500Vp-p noise voltage, 1μs noise width and 25 to 60Hz noise frequency					
	(2) Noise voltage IEC61000-4-4, 2kV					
Dielectric withstand voltage	Across inputs/LG and outputs/FG 2,830VAC rms / 3 cycles (Altitude : 2000m (6561.68ft.))					
Insulation resistance	Across inputs and outputs (LG and FG separated), across inputs and LG/FG, Across outputs and FG/LG. 10MΩ or more by insulation resistance tester (500VDC)					
Ground	Ground resistance : 100 Ω or less					
Cooling method	Natural air-cooling					

(Note-1) : This indicates the section of the power supply to which the equipment is assumed to be connected between the public electrical power distribution network and the machinery within premises.

Category II applies to equipment for which electrical power is supplied from fixed facilities.

The surge voltage withstand level for up to the rated voltage of 300V is 2500V.

(Note-2) : This index indicates the degree to which conductive material is generated in terms of the environment in which the equipment is used.

Pollution level 2 is when only non-conductive pollution occurs. A temporary conductivity caused by condensing must be expected occasionally.

(Note-3) : Do not use or store the Motion CPU module under pressure higher than the atmospheric pressure of altitude 0m. Doing so can cause an operation failure.

 **CAUTION**

- The Motion controller must be stored and used under the conditions listed in the table of specifications above.
- When not using the module for a long time, disconnect the power line from the Motion controller or servo amplifier.
- Place the Motion controller and servo amplifier in static electricity preventing vinyl bags and store.
- When storing for a long time, please contact with our sales representative.

2 SYSTEM CONFIGURATION

2.4 Specifications of Equipment and Settings

2.4.1 Name of parts for CPU module

This section explains the names and setting of the module.

(1) Q173HCPU(-T)/Q172HCPU(-T)

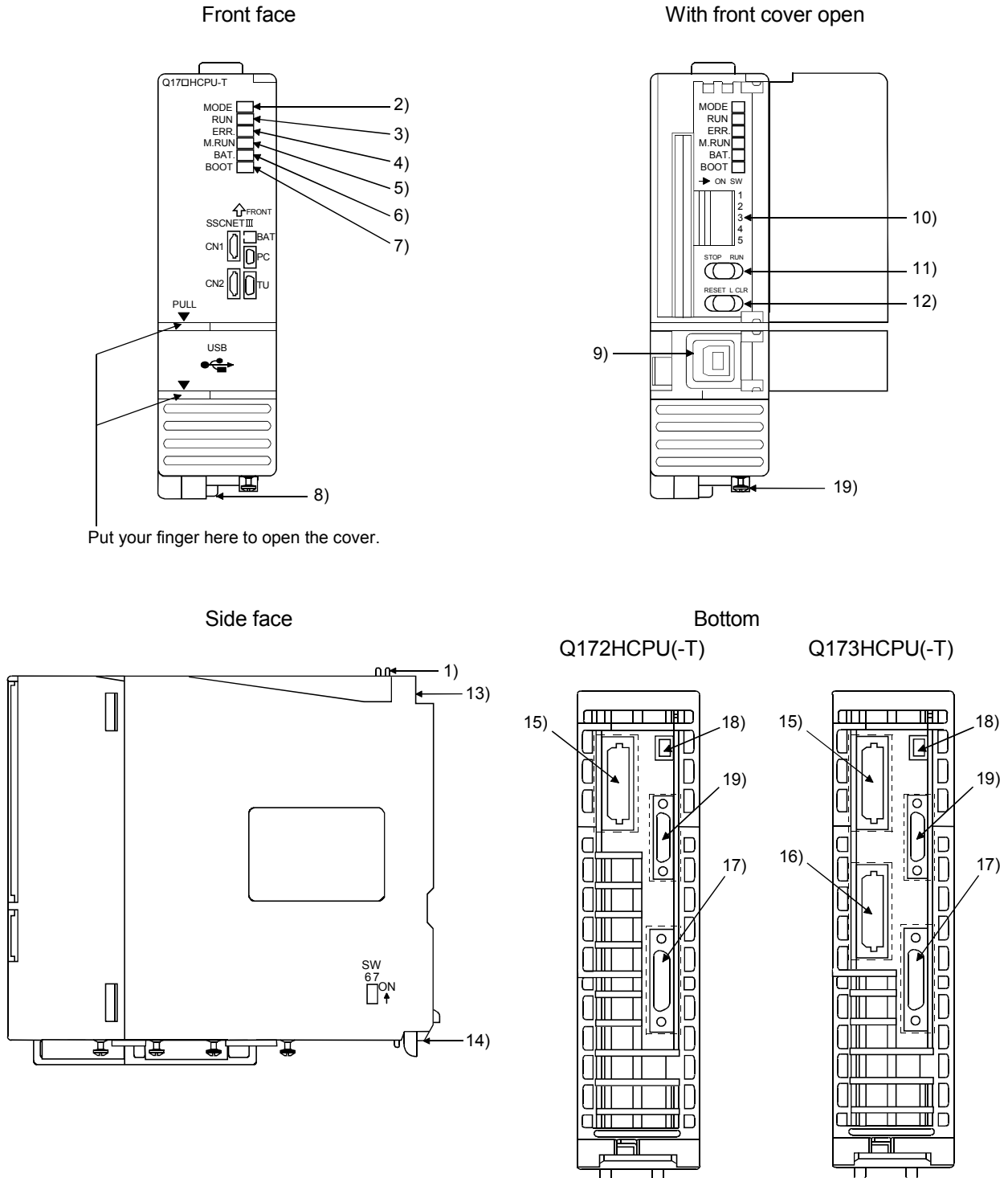

2 SYSTEM CONFIGURATION

No.	Name	Application
1)	Module fixing hook	• Hook used to fix the module to the base unit.(Quick release installation)
2)	MODE LED (Mode judging)	• Lit(green) : Normal mode • Lit(orange) : Installation mode • mode written in ROM
3)	RUN LED	• Lit : Motion CPU normal start • Not lit : Motion CPU fault LED turns off when the trouble occurred at Motion CPU start or WDT error occurrence.
4)	ERR. LED	• Lit : LED turns on at following error occurrence. 1) WDT error 2) System setting error 3) Servo error 4) Self diagnostic error which will not stop the operation (except battery error) 5) Operating system software is not installed. • Flickers : Detection of self diagnostic error which will stop the operation. • Not lit : Normal
5)	M. RUN LED	• Lit : During motion control • Flickers : Latch clear start • Not lit : Not during motion control or detection of self diagnostic error which will stop the operation
6)	BAT. LED	• Lit : Battery error occurrence (External battery use)
7)	BOOT LED	• Lit : Mode operated by ROM • Not lit : Mode operated by RAM/Installation mode • mode written in ROM
8)	Module loading lever	• Used to install the module to the base unit.
9)	USB connector (Note-1)	• Connector for connection with USB-compatible peripheral device. (Connector type B) • It can be connected by USB-dedicated cable.

(Note-1) : When normally connecting a cable to the USB connector, clamp the cable to prevent it from coming off due to the dangling, moving or careless pulling of the cable.

2 SYSTEM CONFIGURATION

(2) Applications of switches, connectors on Q173HCPU/Q172HCPU

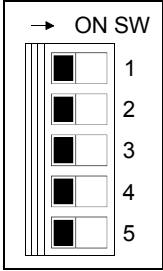
No.	Name	Application
10)	Dip switches 	Dip switch 1 Must not be used. (Shipped from the factory in OFF position)
		Dip switch 2 • ROM operating setting (Shipped from the factory in OFF position) SW2 SW3 OFF OFF → Mode operated by RAM
		Dip switch 3 ON OFF → Must not be set OFF ON → Must not be set ON ON → Mode operated by ROM
		Dip switch 4 Must not be used. (Shipped from the factory in OFF position)
		Dip switch 5 (Installation • ROM writing switch) ON : Installation mode • mode written in ROM OFF : Normal mode (Mode operated by RAM/Mode operated by ROM) • Turn ON dip switch 5 when installed the operating system software into the Motion CPU module from the peripheral device. After completing the installation, move to switch and re-start.
11)	RUN/STOP switch	Move to RUN/STOP. RUN : Motion SFC program (SV13/SV22)/Motion Program (SV43) is started. STOP : Motion SFC program (SV13/SV22)/Motion Program (SV43) is stopped.
12)	RESET/L.CLR switch ^(Note-1) (Momentary switch)	RESET : Set the switch to the "RESET" position once to reset the hardware. Applies a reset after an operation error and initialized the operation. L.CLR : Clear the latch area all data which set with the parameters. (LATCH CLEAR also clears data outside the latch area at this time.) Latch clear operating method 1) Set the "RUN/STOP" switch to "STOP". 2) Move the "RESET/L.CLR" switch to "L.CLR" several times until the "M. RUN LED" flickers. ("M. RUN LED" flickers : Latch clear completed.) 3) Move the "RESET/L.CLR" switch to "L.CLR" once more. ("M. RUN LED" turn off.)
13)	Module fixing screw hole	Hole for the screw used to fix to the base unit. (M3×12 screw : Purchase from the other supplier)
14)	Module fixing hook	Hook used to fix to the base unit.
15)	SSCNETⅢ CN1 connector ^(Note-2)	Connector to connect between Motion CPU module and servo amplifier of system 1 (up to 16 axes)
16)	SSCNETⅢ CN2 connector ^{(Note-2), (Note-3)}	Connector to connect between Motion CPU module and servo amplifier of system 2 (up to 16 axes)
17)	TU connector ^{(Note-4), (Note-5)}	Connector to connect between Motion CPU module and teaching unit
18)	BAT connector	Connector to connect between Motion CPU module and battery holder unit Q170HBATC
19)	PC connector	Connector to connect between Motion CPU module and personal computer via SSCNET

(Note-1) : It is not possible to reset the Multiple CPU system by each of the PLC CPU/Motion CPU No.2 to 4.

 If it is reset, other CPU occurred to stop of the overall Multiple CPU system where MULTI CPU DOWN (Error code : 7000).

 The overall Multiple CPU system reset is resetting the CPU No.1 of PLC CPU.

(Note-2) : Put the SSCNETⅢ cable in the duct or fix the cable at the closest part to the Motion CPU module with bundle material in order to prevent SSCNETⅢ cable from putting its own weight on SSCNETⅢ connector.

(Note-3) : Q173HCPU/Q173HCPU-T only. Teaching unit corresponds to only Japanese.

(Note-4) : Q172HCPU/Q172HCPU-T only. Teaching unit corresponds to only Japanese.

(Note-5) : When connecting the teaching unit, be sure to use the cable which adjusts to the model name of teaching unit.

2 SYSTEM CONFIGURATION

(3) Basic specifications of Q173HCPU/Q172HCPU

(a) Module specifications

Item	Q173HCPU	Q173HCPU-T	Q172HCPU	Q172HCPU-T
Teaching unit	—	Usable	—	Usable
Internal current consumption (5VDC) [A]	1.25	1.56 ^(Note)	1.14	1.45 ^(Note)
Mass [kg]	0.23	0.24	0.22	0.23
Exterior dimensions [mm(inch)]	104.6 (4.11)(H) × 27.4 (1.08)(W) × 114.3 (4.50)(D)			

(Note) : Current consumption 0.26[A] of the teaching unit is included.

(4) SV13/SV22 Motion control specifications/performance specifications

(a) Motion control specifications

Item	Q173HCPU	Q173HCPU-T	Q172HCPU	Q172HCPU-T
Number of control axes	Up to 32 axes		Up to 8 axes	
Operation cycle (default)	SV13	0.44ms/ 1 to 3 axes 0.88ms/ 4 to 10 axes 1.77ms/11 to 20 axes 3.55ms/21 to 32 axes		0.44ms/ 1 to 3 axes 0.88ms/ 4 to 8 axes
	SV22	0.88ms/ 1 to 5 axes 1.77ms/ 6 to 14 axes 3.55ms/15 to 28 axes 7.11ms/29 to 32 axes	—	0.88ms/ 1 to 4 axes 1.77ms/ 5 to 8 axes
Interpolation functions	Linear interpolation (Up to 4 axes), Circular interpolation (2 axes), Helical interpolation (3 axes)			
Control modes	PTP(Point to Point) control, Speed control, Speed-position control, Fixed-pitch feed, Constant speed control, Position follow-up control, Speed control with fixed position stop, Speed switching control, High-speed oscillation control, Synchronous control (SV22)			
Acceleration/ deceleration control	Automatic trapezoidal acceleration/deceleration, S-curve acceleration/deceleration			
Compensation	Backlash compensation, Electronic gear, Phase compensation (SV22)			
Programming language	Motion SFC, Dedicated instruction, Mechanical support language (SV22)			
Servo program capacity	14k steps			
Number of positioning points	3200 points (Positioning data can be designated indirectly)			
Programming tool	IBM PC/AT			
Peripheral I/F	USB/SSCNET			
Teaching operation function	None	Provided (SV13 use)	None	Provided (SV13 use)
Home position return function	Proximity dog type (2 types), Count type (3 types), Data set type (2 types), Dog cradle type, Stopper type (2 types), Limit switch combined type (Home position return re-try function provided, home position shift function provided)			
JOG operation function	Provided			

2 SYSTEM CONFIGURATION

Motion control specifications (continued)

Item	Q173HCPU	Q173HCPU-T	Q172HCPU	Q172HCPU-T
Manual pulse generator operation function	Possible to connect 3 modules			
Synchronous encoder operation function	Possible to connect 12 modules		Possible to connect 8 modules	
M-code function	M-code output function provided M-code completion wait function provided			
Limit switch output function	Number of output points 32 points Watch data: Motion control data/Word device			
Absolute position system	Made compatible by setting battery to servo amplifier. (Possible to select the absolute data method or incremental method for each axis)			
Number of SSCNET III systems <small>(Note-1)</small>	2 systems		1 system	
Motion related interface module	Q172LX : 4 modules usable Q172EX : 6 modules usable Q173PX : 4 modules usable <small>(Note-2)</small>		Q172LX : 1 module usable Q172EX : 4 modules usable Q173PX : 3 modules usable <small>(Note-2)</small>	

(Note-1) : The servo amplifiers for SSCNET cannot be used.

(Note-2) : When using the incremental synchronous encoder (SV22 use), you can use above number of modules.
When connecting the manual pulse generator, you can use only 1 module.

2 SYSTEM CONFIGURATION

(b) Motion SFC performance specifications

Item		Q173HCPU/Q172HCPU		
Motion SFC program capacity	Code total (Motion SFC chart + Operation control + Transition)	543k bytes		
	Text total (Operation control + Transition)	484k bytes		
Motion SFC program	Number of Motion SFC programs	256 (No.0 to 255)		
	Motion SFC chart size/program	Up to 64k bytes (Included Motion SFC chart comments)		
	Number of Motion SFC steps/program	Up to 4094 steps		
	Number of selective branches/branch	255		
	Number of parallel branches/branch	255		
	Parallel branch nesting	Up to 4 levels		
Operation control program (F/FS) / Transition program (G)	Number of operation control programs	4096 with F(Once execution type) and FS(Scan execution type) combined. (F/FS0 to F/FS4095)		
	Number of transition programs	4096(G0 to G4095)		
	Code size/program	Up to approx. 64k bytes (32766 steps)		
	Number of blocks(line)/program	Up to 8192 blocks (in the case of 4 steps(min)/blocks)		
	Number of characters/block	Up to 128 (comment included)		
	Number of operand/block	Up to 64 (operand: constants, word device, bit devices)		
	() nesting/block	Up to 32 levels		
	Descriptive expression	Operation control program	Calculation expression/bit conditional expression	
Transition program		Calculation expression/bit conditional expression/ comparison conditional expression		
Execute specification	Number of multi execute programs	Up to 256		
	Number of multi active steps	Up to 256 steps/all programs		
	Executed task	Normal task	Execute in motion main cycle	
		Event task (Execution can be masked.)	Fixed cycle	Execute in fixed cycle (0.88ms, 1.77ms, 3.55ms, 7.11ms, 14.2ms)
			External interrupt	Execute when input ON is set among interrupt module QI60 (16 points).
			PLC interrupt	Execute with interrupt instruction (S(P).GINT) from PLC CPU.
NMI task	Execute when input ON is set among interrupt module QI60 (16 points).			

2 SYSTEM CONFIGURATION

(5) SV43 Motion control specifications/performance specifications (a) Motion control specifications

Item	Q173HCPU	Q172HCPU
Number of control axes	Up to 32 axes	Up to 8 axes
Operation cycle (default)	0.88ms/ 1 to 5 axes 1.77ms/ 6 to 14 axes 3.55ms/15 to 28 axes 7.11ms/29 to 32 axes	0.88ms/ 1 to 5 axes 1.77ms/ 6 to 8 axes
Interpolation functions	Linear interpolation (Up to 4 axes), Circular interpolation (2 axes), Helical interpolation (3 axes)	
Control modes	PTP (Point to Point) control, Constant speed positioning, High-speed oscillation control	
Acceleration/ deceleration control	Automatic trapezoidal acceleration/deceleration, S-curve acceleration/deceleration	
Compensation	Backlash compensation, Electronic gear	
Programming language	Dedicated instruction (EIA language)	
Motion program capacity	248k bytes	
Number of programs	1024	
Number of simultaneous start programs	Axis designation program : 32 Control program : 16	Axis designation program : 8 Control program : 16
Number of positioning points	Approx. 10600 points (Positioning data can be designated indirectly)	
Programming tool	IBM PC/AT	
Peripheral I/F	USB/SSCNET	
Teaching operation function	None	
Home position return function	Proximity dog type (2 types), Count type (3 types), Data set type (2 types), Dog cradle type, Stopper type (2 types), Limit switch combined type (Home position return re-try function provided, home position shift function provided)	
JOG operation function	Provided	
Manual pulse generator operation function	Possible to connect 3 modules	
M-code function	M-code output function provided M-code completion wait function provided	
Limit switch output function	Number of output points 32 points Watch data: Motion control data/Word device	
Skip function	Provided	
Override ratio setting function	Override ratio setting : 0 to 100[%]	
Absolute position system	Made compatible by setting battery to servo amplifier. (Possible to select the absolute data method or incremental method for each axis)	
Number of SSCNET III systems <small>(Note-1)</small>	2 systems	1 system
Number of Motion related modules	Q172LX : 4 modules Q173PX : 1 module	Q172LX : 1 module Q173PX : 1 module

(Note-1) : The servo amplifiers for SSCNET cannot be used.

2 SYSTEM CONFIGURATION

(b) Motion program performance specifications

Item		Q173HCPU/Q172HCPU
Program capacity	Total of program files	248k bytes
	Number of programs	Up to 1024 (No. 1 to 1024)
Operation controls	Arithmetic operation	Unary operation, Addition and subtraction operation, Multiplication and division operation, Remainder operation
	Comparison operation	Equal to, Not equal to
	Logical operation	Logical shift operation, Logical negation, Logical AND, Logical OR, Exclusive OR
G-codes	Positioning command	G00, G01, G02, G03, G04, G09, G12, G13, G23, G24, G25, G26, G28, G30, G32, G43, G44, G49, G53, G54, G55, G56, G61, G64, G90, G91, G92, G98, G99, G100, G101
M-codes	Output command to data register	M****
Special M-codes	Program control command	M00, M01, M02, M30, M98, M99, M100
Variable	Device variable	X, Y, B, F, D, W, #
Functions	Trigonometric function	SIN, COS, TAN, ASIN, ACOS, ATAN
	Numerical function	ABS, SQR, BIN, LN, EXP, BCD, RND, FIX, FUP, INT, FLT, DFLT, SFLT
Instructions	Start/end	CALL, CLEAR
	Home position return	CHGA
	Speed/torque setting	TL, CHGV, CHGT
	Motion control	WAITON, WAITOFF, EXEON, EXEOFF
	Jump/repetition processing	CALL, GOSUB/GOSUBE, IF...GOTO, IF...THEN...ELSE...END, WHILE...DO...END
	Data operation	BMOV, BDMOV, FMOV, BSET, BRST, SET, RST, MULTW, MULTR, TO, FROM, ON, OFF, IF...THEN...SET/RST/OUT, PB
Number of controls	Number of program calls (GOSUB/GOSUBE)	Up to 8
	Number of program calls (M98)	Up to 8

2 SYSTEM CONFIGURATION

(6) Selection of Q172EX, Q173PX

Item	Synchronous encoder		Manual pulse generator
	Serial absolute	Incremental	
Q173HCPU	12 modules		3 modules
Q172HCPU	8 modules		
Module selection	Q172EX	Q173PX	

(7) Q173HCPU/Q172HCPU internal rechargeable battery

- Initial charging of the Q173HCPU/Q172HCPU

Turn on the power supply and charge the internal rechargeable battery for eight hours or more, before starting to use the Q173HCPU/Q172HCPU. It is possible to provide backup power for the IC-RAM memory for at least 200 hours by charging the internal rechargeable battery for eight hours or more, even if it is empty.

If the battery is charged for five days while applying power eight hours a day, i.e., 40 hours of normal operation, it will be able to provide backup power for the IC-RAM memory for 1100 hours.

Battery backup by the external battery will be necessary if there is a possibility that a continuous power off that lasts longer than the continuous power failure hours for the internal rechargeable battery specified in the table below may occur, for example when transporting the system on a ship.

Item		Continuous power failure time [h]	
		Guaranteed time (MIN)	Actual time (TYP)
Internal rechargeable battery	Charging time: 8 hours or more	200	500
	Charging time: 40 hours or more	1100	4300

2 SYSTEM CONFIGURATION

2.4.2 Power supply module

(1) Table of the power supply module specifications

This section describes the power supply modules specifications.

Item		Q61P-A1	Q61P-A2	Q61P	Q62P
Base loading position		Power supply module loading slot			
Applicable base unit		Q33B, Q35B, Q38B, Q312B, Q65B, Q68B, Q612B			
Input power supply		100 to 120VAC (+10%/-15%) (85 to 132VAC)	200 to 240VAC (+10%/-15%) (170 to 264VAC)	100 to 240VAC (+10%/-15%) (85 to 264VAC)	
Input frequency		50/60Hz ±5%			
Input voltage distortion factor		5% or less			
Max. input apparent power		105VA		130VA	105VA
Inrush current		20A 8ms or less (Note-4)			
Rated output current	5VDC	6A			3A
	24VDC	—			0.6A
External output voltage		—			24VDC±10%
Overcurrent protection (Note-1)	5VDC	6.6A or more			3.3A or more
	24VDC	—			0.66A or more
Overvoltage protection (Note-2)	5VDC	5.5 to 6.5V			
Efficiency		70% or more			65% or more
Allowable momentary power failure time (Note-3)		20ms or less			
Dielectric withstand voltage		Across inputs/LG and outputs/FG 2,830VAC rms / 3 cycles (Altitude : 2000m (6561.68ft.))			
Insulation resistance		Across inputs and outputs (LG and FG separated), across inputs and LG/FG, across outputs and LG/FG 10MΩ or more by insulation resistance tester (500VDC)			
Noise immunity		<ul style="list-style-type: none"> • By noise simulator of 1,500Vp-p noise voltage, 1μs noise width and 25 to 60Hz noise frequency • Noise voltage IEC61000-4-4, 2kV 			
Operation indication		LED indication (Normal : ON (Green), Error : OFF)			
Fuse		Built-in (Unchangeable by user)			
Contact output section	Application	ERR contact (contact switched off (opened: normally closed contact) at an error stop of CPU), for CPU module operating status output			
	Rated switching voltage/current	24VDC, 0.5A			
	Minimum switching load	5VDC, 1mA			
	Response time	OFF to ON: 10ms or less. ON to OFF: 12ms or less.			
	Life time	Mechanical : 20 million times or more Electrical : 100 thousand times at rated switching voltage/current or more			
	Surge suppressor	None			
	Fuse	None			
Terminal screw size		M3.5 screw			
Applicable wire size		0.75 to 2mm ²			
Applicable crimping terminal		RAV1.25 to 3.5, RAV2 to 3.5			
Applicable tightening torque		0.66 to 0.89 N•m			
Exterior dimensions[mm(inch)]		98(H) × 55.2(W) × 90(D) (3.86(H) × 2.17(W) × 3.54(D))			
Mass [kg]		0.31		0.40	0.39

2 SYSTEM CONFIGURATION

The power supply module specifications (continued)

Item		Q63P	Q64P
Base loading position		Power supply module loading slot	
Applicable base unit		Q33B, Q35B, Q38B, Q312B, Q65B, Q68B, Q612B	
Input power supply		24VDC (+30%/-35%) (15.6 to 31.2VDC)	100 to 120VAC/200 to 240VAC (+10%/-15%) (85 to 132VAC/170 to 264VAC)
Input frequency		—	50/60Hz ±5%
Input voltage distortion factor		—	5% or less
Max. input apparent power		45W	160VA
Inrush current		100A 1ms or less (at 24VDC input)	20A 8ms or less (Note-4)
Rated output current	5VDC	6A	8.5A
	24VDC	—	—
Overcurrent protection (Note-1)	5VDC	6.6A or more	9.9A or more
	24VDC	—	—
Overvoltage protection (Note-2)	5VDC	5.5 to 6.5V	
	24VDC	—	
Efficiency		70% or more	
Permissible instantaneous power off time (Note-3)		10ms or less (at 24VDC input)	20ms or less
Dielectric withstand voltage		500VAC across primary and 5VDC	Across inputs/LG and outputs/FG 2,830VAC rms/3 cycles (Altitude : 2000m (6561.68ft.))
Insulation resistance		10MΩ or more by insulation resistance tester	Across inputs and outputs (LG and FG separated), across inputs and LG/FG, across outputs and LG/FG 10MΩ or more by insulation resistance tester (500VDC)
Noise immunity		• By noise simulator of 500Vp-p noise voltage, 1μs noise width and 25 to 60Hz noise frequency	• By noise simulator of 1,500Vp-p noise voltage, 1μs noise width and 25 to 60Hz noise frequency • Noise voltage IEC61000-4-4, 2kV
Operation indication		LED indication (Normal : ON (Green), Error : OFF)	
Fuse		Built-in (Unchangeable by user)	
Contact output section	Application	ERR contact (contact switched off (opened: normally closed contact) at an error stop of CPU), for CPU module operating status output	
	Rated switching voltage/current	24VDC, 0.5A	
	Minimum switching load	5VDC, 1mA	
	Response time	OFF to ON: 10ms or less. ON to OFF: 12ms or less	
	Life time	Mechanical : 20 million times or more Electrical : 100 thousand times at rated switching voltage/current or more	
	Surge suppressor	None	
	Fuse	None	
Terminal screw size		M3.5 screw	
Applicable wire size		0.75 to 2mm ²	
Applicable crimping terminal		RAV1.25 to 3.5, RAV2 to 3.5	
Applicable tightening torque		0.66 to 0.89 N•m	
Exterior dimensions[mm(inch)]		98(H) × 55.2(W) × 90(D) (3.86(H) × 2.17(W) × 3.54(D))	98(H) × 55.2(W) × 115(D) (3.86(H) × 2.17(W) × 4.53(D))
Mass [kg]		0.33	0.40

POINTS

(Note-1) : Overcurrent protection

The overcurrent protection device shuts off the 5V, 24VDC circuit and stops the system if the current flowing in the circuit exceeds the specified value.

The LED of the power supply module is turned off or lights up in dim green when voltage is lowered. If this device is activated, switch the input power supply off and eliminate the cause such as insufficient current capacity or short. Then, a few minutes later, switch it on to restart the system.

The initial start for the system takes place when the current value becomes normal.

(Note-2) : Overvoltage protection

The overvoltage protection device shuts off the 5VDC circuit and stops the system if a voltage of 5.5VDC or more is applied to the circuit.

When this device is activated, the power supply module LED is switched OFF.

If this happens, switch the input power OFF, then a few minutes later ON. This causes the initial start for the system to take place. The power supply module must be changed if the system is not booted and the LED remains OFF.

POINTS

(Note-3) : Allowable momentary power failure period

(1) For AC input power supply (QX10, etc.)

- An instantaneous power failure lasting less than 20ms will cause AC down to be detected, but operation will continue.
- An instantaneous power failure lasting in excess of 20ms may cause the operation to continue or initial start to take place depending on the power supply load.

Further, when the AC supply of the AC input module is the same as that of the power supply module, it prevents the sensor connected to the AC input module, which is ON at power-off, from turning OFF by switching off the power supply.

However, if only the AC input module is connected to the AC line, which is connected to the power supply, detection of the AC down for the power supply module may be delayed by the capacitor in the AC input module. Thus, connect a load of approx. 30mA per AC input module to the AC line.

(2) For DC input power supply

- An instantaneous power failure lasting less than 10ms^(Note) will cause 24VDC down to be detected, but operation will continue.
- An instantaneous power failure lasting in excess of 10ms^(Note) may cause the operation to continue or initial start to take place depending on the power supply load.

(Note) : This is for a 24VDC input. This is 10ms or less for less than 24VDC.

(Note-4) : Inrush current

When power is switched on again immediately (within 5 seconds) after power-off, an inrush current of more than the specified value (2ms or less) may flow. Reapply power 5 seconds after power-off.

When selecting a fuse and breaker in the external circuit, take account of the blow out, detection characteristics and above matters.

2 SYSTEM CONFIGURATION

(2) Names of Parts and Setting

This section describes the names of the parts of each power module.

- Q61P-A1 (100 to 120VAC input, 5VDC 6A output)
- Q61P-A2 (200 to 240VAC input, 5VDC 6A output)
- Q61P (100 to 240VAC input, 5VDC 6A output)
- Q62P (100 to 240VAC input, 5VDC 3A/24VDC 0.6A output)
- Q63P (24VDC input, 5VDC 6A output)
- Q64P (100 to 120VAC/200 to 240VAC input, 5VDC 8.5A output)

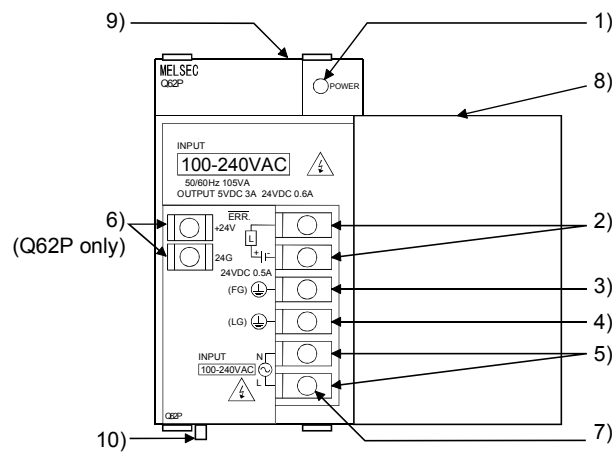

2 SYSTEM CONFIGURATION

No.	Name	Application
1)	POWER LED	ON (green): Normal (5VDC output, momentary power failure within 20ms) OFF : • AC power supply is ON, however, the power supply module is out of order. (5VDC error, internal circuit failure, blown fuse) • Over current protection or over voltage protection operated. • AC power supply is not ON • Power failure (including an momentary power failure of more than 20ms)
		ON (green): Normal (5VDC output, momentary power failure within 10ms) OFF : • DC power supply is ON, however, the power supply module is out of order. (5VDC error, internal circuit failure, blown fuse) • Over current protection or over voltage protection operated. • DC power supply is not ON • Power failure (including an momentary power failure of more than 10ms)
2)	ERR terminals	• Turned ON when the whole system operates normally. • This terminal turns OFF (opens) when the AC power is not input, a stop error (including a reset) occurs in the CPU module, or the fuse is blown. • In a Multiple CPU system configuration, turned OFF (opens) when a stop error occurs in any of the CPU modules. Normally OFF when loaded in an extension base unit.
		• Turned ON when the whole system operates normally. • This terminal turns OFF (opens) when the DC power is not input, a stop error (including a reset) occurs in the CPU module, or the fuse is blown. • In a Multiple CPU system configuration, turned OFF (opens) when a stop error occurs in any of the CPU modules. Normally OFF when loaded in an extension base unit.
3)	FG terminal	Ground terminal connected to the shield pattern of the printed circuit board.
4)	LG terminal	Grounding for the power supply filter. The potential of Q61P-A1, Q61P-A2, Q61P, Q62P and Q64P terminal is 1/2 of the input voltage.
5)	Power input terminals	• Power input terminals connected to a power supply of 100VAC or 200VAC. (Q61P-A1, Q61P-A2, Q64P) • Power input terminals connected to a power supply of 100VAC to 200VAC. (Q61P, Q62P) • Power input terminals connected to a power supply of 24VDC. (Q63P)
6)	+24V, 24G terminals	Used to supply 24VDC power to inside the output module. (using external wiring)
7)	Terminal screw	M3.5×7 screw
8)	Terminal cover	Protective cover of the terminal block
9)	Module fixing screw hole	Used to fix the module to the base unit. M3×12 screw (user-prepared) (Tightening torque : 0.36 to 0.48 N•m)
10)	Module loading lever	Used to load the module into the base unit.

2 SYSTEM CONFIGURATION

POINTS

- (1) The Q61P-A1 is dedicated for inputting a voltage of 100VAC.
Do not input a voltage of 200VAC into it or trouble may occur on the Q61P-A1.

Power module type	Supply power voltage	
	100VAC	200VAC
Q61P-A1	Operates normally.	Power supply module causes trouble.
Q61P-A2	Power supply module does not cause trouble. CPU module cannot be operated.	Operates normally.

- (2) The Q63P is dedicated for inputting a voltage of 24VDC.
Do not input a voltage of except 24VDC into it or trouble may occur on the Q63P.
- (3) Q64P automatically switches the input range 100/200VAC.
Therefore, it is not compatible with the intermediate voltage (133 to 169VAC).
The CPU module may not work normally if the above intermediate voltage is applied.
- (4) Ensure that the earth terminals LG and FG are grounded.
(Ground resistance : 100 Ω or loss)
- (5) When the Q61P-A1, Q61P-A2, Q61P, Q62P, Q63P or Q64P is loaded on the extension base unit, a system error cannot be detected by the ERR terminal.
(The ERR terminal is always OFF.)

2 SYSTEM CONFIGURATION

(3) Selection of the power supply module

The power supply module is selected according to the total of current consumption of the I/O modules, special function module, and peripheral devices supplied by its power module. (Select the power supply module in consideration of the current consumption of the peripheral device connected to the Q170ENC, MR-HDP01 or A31TU-D3□/A31TU-DN□, etc.)

For information about the current consumption of 5VDC of the I/O modules, special function module, and peripheral device, refer to the QCPU User's Manual (Hardware Design, Maintenance and Inspection).

The current consumption of Motion controller is as follows.

Part name	Model name	Description	Current consumption 5VDC [A]
Motion CPU module	Q173HCPU	Up to 32 axes control	1.25
	Q173HCPU-T	Up to 32 axes control, For teaching unit	1.56 ^(Note-2)
	Q172HCPU	Up to 8 axes control	1.14
	Q172HCPU-T	Up to 8 axes control, For teaching unit	1.45 ^(Note-2)
Servo external signal interface module	Q172LX	Servo external signal 8 axes (FLS, RLS, STOP, DOG/CHANGE×8)	0.05
Serial absolute synchronous encoder interface module ^(Note-1)	Q172EX-S2	Serial absolute synchronous encoder Q170ENC interface×2, Tracking input 2 points	0.07
	Q172EX-S3	Serial absolute synchronous encoder Q170ENC interface×2, Tracking input 2 points, Memory built-in for data exchange	
Manual pulse generator interface module ^(Note-1)	Q173PX	Manual pulse generator MR-HDP01/Incremental synchronous encoder interface×3, Tracking input 3 points	0.11
	Q173PX-S1	Manual pulse generator MR-HDP01/Incremental synchronous encoder interface×3, Tracking input 3 points, Memory built-in for data exchange	
Manual pulse generator	MR-HDP01	Pulse resolution: 25PLS/rev (100 PLS/rev after magnification by 4) Permitted axial loads Radial load: Up to 19.6N Thrust load: Up to 9.8N Permitted speed: 200r/min (Normal rotation), Voltage output	0.06
Teaching unit	A31TU-D3K13	For SV13, With 3-position deadman switch	0.26
	A31TU-DNK13	For SV13, Without deadman switch	
Serial absolute synchronous encoder	Q170ENC	Resolution: 262144PLS/rev Permitted axial loads Radial load: up to 19.6N Thrust load: up to 9.8N Permitted speed: 3600r/min	0.20

(Note-1) : Select the power supply module in consideration of the current consumption of connecting peripheral device (Q170ENC or MR-HDP01).

(Note-2) : Current consumption of A31TU-D3□/A31TU-DN□ is included.

2 SYSTEM CONFIGURATION

(4) Example of the power supply selection calculation (When using the Q173HCPU-T.)

(a) System configuration

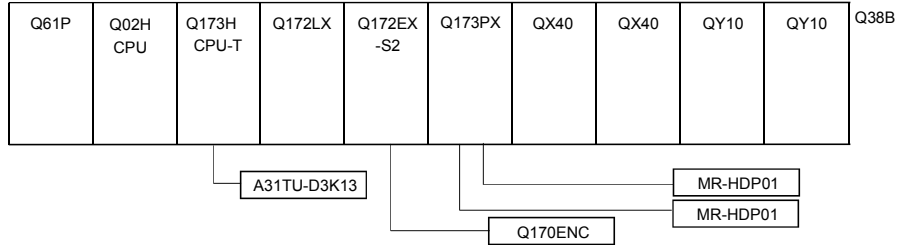

(b) 5VDC current consumption of each module

Q02H CPU	: 0.64 [A]	Q173PX	: 0.11 [A]
Q173H CPU-T ^(Note)	: 1.56 [A]	MR-HDP01	: 0.06 [A]
Q172LX	: 0.05 [A]	QX40	: 0.05 [A]
Q172EX-S2	: 0.07 [A]	QY10	: 0.43 [A]
Q170ENC	: 0.20 [A]	Q38B	: 0.114 [A]

(Note) : Current consumption of A31TU-D3K13(0.26A) is included.

(c) Power consumption of overall modules

$$I_{5V} = 0.64 + 1.56 + 0.05 + 0.07 + 0.20 + 0.11 + 0.06 \times 2 + 0.05 \times 2 + 0.43 \times 2 + 0.114 = 3.824[A]$$

Select of the power supply module (Q61P (100/240VAC) 6A) according to this internal current consumption 3.824[A].

(Note) : Configure the system in such a way that the total current consumption at 5VDC of all the modules is less than the allowable value.

2 SYSTEM CONFIGURATION

2.4.3. Base unit and extension cable

This section describes the specifications of the extension cables for the base units (CPU base unit or extension base unit) used in the system, and the specification standards of the extension base unit.

(1) Table of the base unit specifications

(a) CPU base unit specifications

Type \ Item	Q33B	Q35B	Q38B	Q312B
Number of I/O modules	3	5	8	12
Possibility of extension	Extendable			
Applicable module	Q series modules			
5VDC internal current consumption [A]	0.105	0.110	0.114	0.121
Fixing hole size	M4 screw hole or $\phi 4.5$ hole (for M4 screw)			
Exterior dimensions [mm(inch)]	189(W) \times 98(H) \times 44.1(D) (7.44(W) \times 3.86(H) \times 1.74(D))	245(W) \times 98(H) \times 44.1(D) (9.65(W) \times 3.86(H) \times 1.74(D))	328(W) \times 98(H) \times 44.1(D) (12.91(W) \times 3.86(H) \times 1.74(D))	439(W) \times 98(H) \times 44.1(D) (17.28(W) \times 3.86(H) \times 1.74(D))
Mass [kg]	0.21	0.25	0.35	0.45
Attachment	Fixing screw M4 \times 14 4 pieces (DIN rail fixing adapter is optional)			
DIN rail fixing adapter type	Q6DIN3	Q6DIN2	Q6DIN1	

(b) Extension base unit specifications

Type \ Item	Q63B	Q65B	Q68B	Q612B
Number of I/O modules	3	5	8	12
Possibility of extension	Extendable			
Applicable module	Q series modules			
5VDC internal current consumption [A]	0.105	0.110	0.114	0.121
Fixing hole size	M4 screw hole or $\phi 4.5$ hole (for M4 screw)			
Exterior dimensions [mm(inch)]	189(W) \times 98(H) \times 44.1(D) (7.44(W) \times 3.86(H) \times 1.74(D))	245(W) \times 98(H) \times 44.1(D) (9.65(W) \times 3.86(H) \times 1.74(D))	328(W) \times 98(H) \times 44.1(D) (12.91(W) \times 3.86(H) \times 1.74(D))	439(W) \times 98(H) \times 44.1(D) (17.28(W) \times 3.86(H) \times 1.74(D))
Mass [kg]	0.23	0.25	0.35	0.45
Attachment	Fixing screw M4 \times 14 4 pieces (DIN rail fixing adapter is optional)			
DIN rail fixing adapter type	Q6DIN3	Q6DIN2	Q6DIN1	

2 SYSTEM CONFIGURATION

(2) Table of the extension cable specifications

The list below describes the specifications of the extension cables which can be used for the PLC CPU system.

Item \ Type	QC05B	QC06B	QC12B	QC30B	QC50B	QC100B
Cable length[m(ft.)]	0.45(1.48)	0.6(1.97)	1.2(3.94)	3.0(9.84)	5.0(16.40)	10.0(32.81)
Application	Connection between the CPU base unit and extension base unit, or connection between the extension base units.					
Mass [kg]	0.15	0.16	0.22	0.40	0.60	1.11

POINT

When the extension cables are used in combination, limit the overall length of the combined cable to 13.2m (43.31ft.).

(3) Names of parts of the base unit

Names of parts of the base unit are described below.

(a) CPU base unit (Q33B, Q35B, Q38B, Q312B)

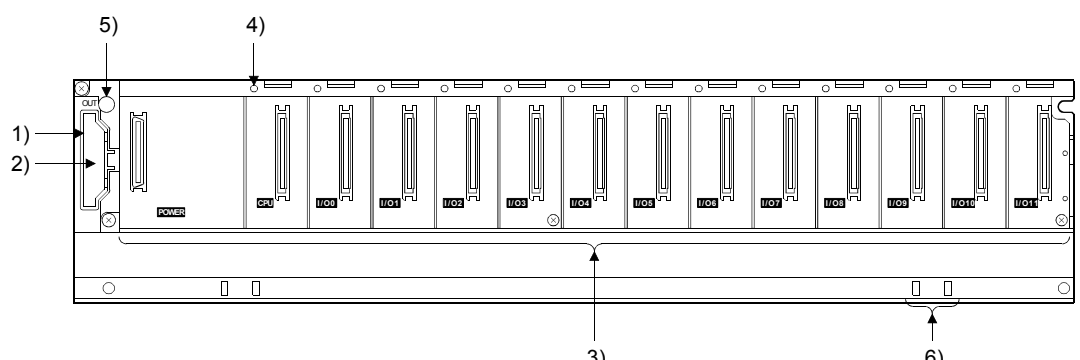

No.	Name	Application
1)	Extension cable connector	Connector for sending and receiving signals from the extension base unit, to which the extension cables are connected.
2)	Base cover	Protective cover of extension cable connector. Before an extension cable is connected, the area of the base cover surrounded by the groove under the word "OUT" on the base cover must be removed with a tool such as nippers.
3)	Module connector	Connector for installing the power supply module, CPU module, I/O modules, and intelligent function module. To the connectors located in the spare space where these modules are not installed, attach the supplied connector cover or the blank cover module QG60 to prevent entry of dirt.
4)	Module fixing screw hole	Screw hole for fixing the module to the base. Screw size: M3 × 12
5)	Base fixing hole	Hole for fixing this base unit onto the panel of the control panel (for M4 × 14 screw)
6)	DIN rail adapter fixing hole	Hole for fixing DIN rail adapter

2 SYSTEM CONFIGURATION

(4) I/O allocations

It is possible to allocate unique I/O No.s for each Motion CPU independently of the PLC's I/O No.s. (I/O No.s are unique between the Q series PLC CPU within a given system, but the I/O No.s of the Motion CPU are unique for each Motion CPU.)

ON/OFF data input to the Motion CPU is handled via input devices PX□□, while ON/OFF data output from the Motion CPU is handled via output devices PY□□. It is not mandatory to match the I/O device PX/PY No.s used in the Motion program with the PLC I/O No.s; but it is recommended to make them match as much as possible.

The following figure shows an example of I/O allocation.

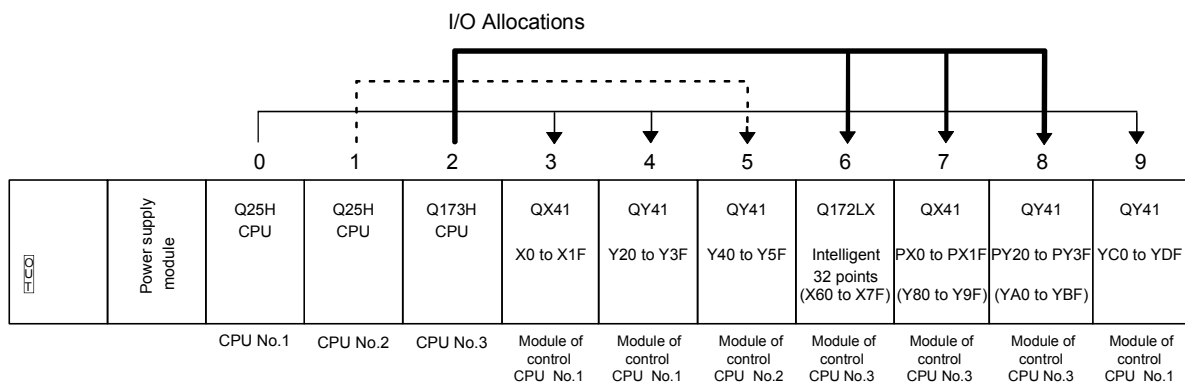

(Note-1) : When the number of modules to be installed is 32 points.

(Note-2) : When the PX/PY No. does not match the PLC I/O No.

Refer to the Q173HCPU/Q172HCPU Motion Controller Programming Manual (COMMON) about the I/O allocation setting method,.

Refer to the QCPU User's Manual (Function Explanation, Program Fundamentals) about the I/O allocation setting method of the Qn(H)CPU.

POINT

I/O device of the Motion CPU can be set in the range PX/PY000 to PX/PYFFF.
The real I/O points must be 256 points or less. (As for the I/O No., it is possible not to continue.)

2 SYSTEM CONFIGURATION

2.4.4 Q172LX Servo external signals interface module

Q172LX receives external signals (servo external signals) required for positioning control.

(1) Q172LX name of parts

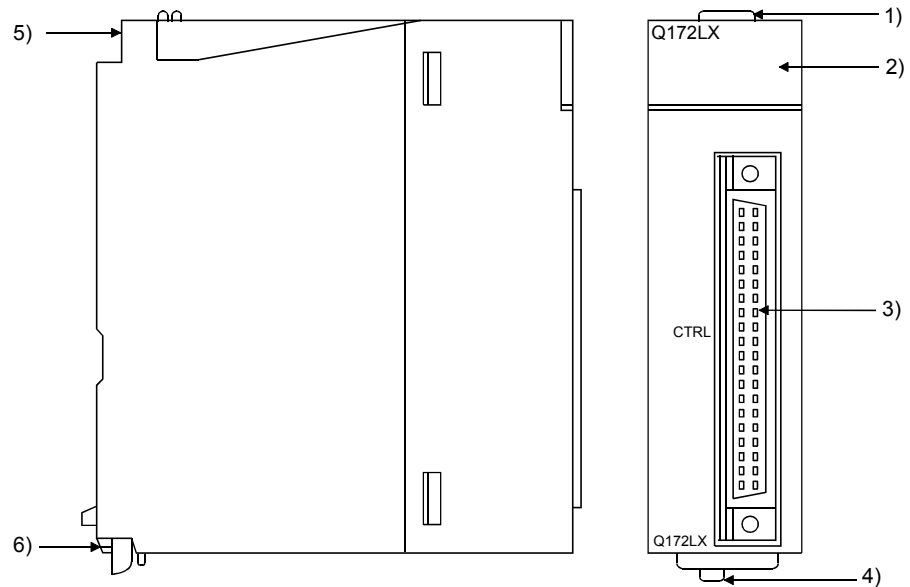

No.	Name	Application				
1)	Module fixing hook	Hook used to fix the module to the base unit. (Quick release installation)				
2)	Mode judging LED	Display the servo external input status from the external equipment. <table border="1" style="margin-left: 20px;"> <thead> <tr> <th>LED</th> <th>Details</th> </tr> </thead> <tbody> <tr> <td>0 to 1F</td> <td>Indicates to display the servo external signal input status of each axis.</td> </tr> </tbody> </table> <p>This LED is not turned on if it is not set the Q172LX in the system settings.</p>	LED	Details	0 to 1F	Indicates to display the servo external signal input status of each axis.
LED	Details					
0 to 1F	Indicates to display the servo external signal input status of each axis.					
3)	CTRL connector	The servo external signal input connector of each axis.				
4)	Module loading lever	Used to install the module to the base unit.				
5)	Module fixing screw hole	Hole for the screw used to fix to the base unit. (M3×12 screw : Purchase from the other supplier)				
6)	Module fixing hook	Hook used to fix to the base unit.				

POINT

Mode judging LED turns ON at the following conditions.

- Q172LX is set on the system setting display of SW6RN-GSV□P.
- DOG/CHANGE signal is input.

2 SYSTEM CONFIGURATION

(2) Performance specifications

(a) Module specifications

Item	Specifications
Number of I/O occupying points	32 points(I/O allocation: Intelligent, 32 points)
Internal current consumption(5VDC) [A]	0.05
Exterior dimensions [mm(inch)]	98(H)× 27.4(W)× 90(D) (3.86(H)× 1.08(W)× 3.54(D))
Mass [kg]	0.15

(b) Input

Item	Specifications
Number of input points	Servo external signals : 32 points (Upper stroke limit, Lower stroke limit, Stop input, Proximity dog/Speed-position switching signal) (4 points × 8 axes)
Input method	Sink/Source type
Isolation method	Photocoupler
Rated input voltage	12/24VDC
Rated input current	12VDC 2mA/24VDC 4mA
Operating voltage range	10.2 to 26.4VDC (12/24VDC +10/-15%, ripple ratio 5% or less)
ON voltage/current	10VDC or more/2.0mA or more
OFF voltage/current	1.8VDC or less/0.18mA or less
Input resistance	Approx. 5.6kΩ
Response time of the Upper/Lower stroke limit and STOP signal	OFF to ON ON to OFF 1ms
Response time of the proximity dog, Speed- position switching signal	OFF to ON ON to OFF 0.4ms/0.6ms/1ms (CPU parameter setting, Default 0.4ms)
Common terminal arrangement	32 points/common (common terminal: B1, B2)
Indicates to display	ON indication (LED)
External connector type	40 pin connector
Applicable wire size	0.3mm ²
Applicable connector for the external connection	A6CON1(Attachment), A6CON2, A6CON3(Optional)
Applicable connector/ Terminal block converter module	A6TBXY36, A6TBXY54, A6TBXY70(Optional)

2 SYSTEM CONFIGURATION

(3) Connection of servo external signals interface module

(a) Servo external signals

There are the following servo external signals.

(Upper stroke limit is limit value of address increase direction/lower stroke limit is limit value of an address decrease direction.)

The Q172LX is assigned a set of input No.s per axis. Make the system setting of the positioning software package to determine the I/O No.s corresponding to the axis No.s.

Servo external signal	Application	Number of points on one Q172LX
Upper stroke limit input (FLS)	For detection of upper and lower stroke limits.	32 points (4 points/8 axes)
Lower stroke limit input (RLS)		
Stop signal input (STOP)	For stopping under speed or positioning control.	
Proximity dog/ Speed-position switching input (DOG/CHANGE)	For detection of proximity dog at proximity dog or count type home position return of for switching from speed to position switching control.	

2 SYSTEM CONFIGURATION

(b) The pin layout of the CTRL connector

Use the CTRL connector at the Q172LX module front to connect the servo external signals.

The following pin layout of the Q172LX CTRL connector viewed from the front.

The pin layout and connection description of the CTRL connector are described below.

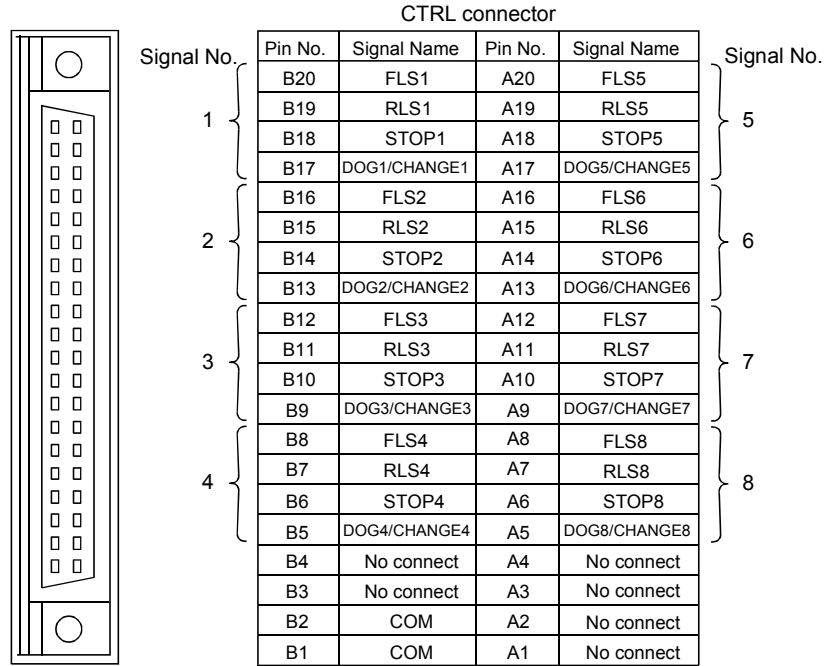

Applicable connector model name

A6CON1 type soldering type connector
 FCN-361J040-AU connector (FUJITSU TAKAMISAWA COMPONENT LIMITED)
 FCN-360C040-B connector cover

(Attachment)

A6CON2 type Crimp-contact type connector
 A6CON3 type Pressure-displacement type connector

(Optional)

DOG/CHANGE, STOP, RLS, FLS functions of each axis(1 to 8)	
DOG/CHANGE	Proximity dog/Speed-position switching signal
STOP	Stop signal
RLS	Lower stroke limit
FLS	Upper stroke limit

For information about signal details, refer to the programming manual.

(Note) : Connector/terminal block conversion modules and cables can be used at the wiring of CTRL connector.

A6TBXY36/A6TBXY54/A6TBX70 : Connector/terminal block conversion module

AC□TB (□:Length [m]) : Connector/terminal block conversion cable

POINT

Signal No. 1 to 8 can be assigned to the specified axis. To make assignment, make the system settings of the positioning software package.

2 SYSTEM CONFIGURATION

(4) Interface between CTRL connector and servo external signal

Input or Output	Signal name	CTRL connector	LED	Wiring example	Internal circuit	Specification	Description
Input	FLS1	B20	0	Upper stroke limit input	5.6k Ω	• Supply voltage 12 to 24 VDC (10.2 to 26.4 VDC, stabilized power supply)	FLS
	FLS2	B16	4				
	FLS3	B12	8				
	FLS4	B8	C				
	FLS5	A20	10				
	FLS6	A16	14				
	FLS7	A12	18				
	FLS8	A8	1C				
	RLS1	B19	1	Lower stroke limit input	5.6k Ω	• High level 10.0 VDC or more/ 2.0mA or more	RLS
	RLS2	B15	5				
	RLS3	B11	9				
	RLS4	B7	D				
	RLS5	A19	11				
	RLS6	A15	15				
	RLS7	A11	19				
	RLS8	A7	1D				
	STOP1	B18	2	Stop signal input	5.6k Ω	• Low level 1.8 VDC or less/ 0.18mA or less	STOP
	STOP2	B14	6				
	STOP3	B10	A				
	STOP4	B6	E				
	STOP5	A18	12				
	STOP6	A14	16				
	STOP7	A10	1A				
	STOP8	A6	1E				
DOG/CHANGE1	B17	3	Proximity dog /Speed-position switching signal	5.6k Ω		DOG/CHANGE	
DOG/CHANGE2	B13	7					
DOG/CHANGE3	B9	B					
DOG/CHANGE4	B5	F					
DOG/CHANGE5	A17	13					
DOG/CHANGE6	A13	17					
DOG/CHANGE7	A9	1B					
DOG/CHANGE8	A5	1F					
Power supply (Note)		B1 B2					Common terminals for motion control signals, external signal.
				12VDC to 24VDC			

(Note): As for the connection to power line (B1, B2), both "+" and "-" are possible.

! CAUTION

- Always use a shield cable for connection of the CTRL connector and external equipment, and avoid running it close to or bundling it with the power and main circuit cables to minimize the influence of electromagnetic interface. (Separate them more than 200mm (0.66ft.) away.)
- Connect the shield wire of the connection cable to the FG terminal of the external equipment.
- Make parameter setting correctly. Incorrect setting may disable the protective functions such as stroke limit protection.
- Always wire the cables when power is off. Not doing so may damage the circuit of modules.
- Wire the cable correctly. Wrong wiring may damage the internal circuit.

2 SYSTEM CONFIGURATION

2.4.5 Q172EX Serial absolute synchronous encoder interface module

Q172EX receive external signals required for serial absolute synchronous encoder.
The installation position of Q172EX is only CPU base.

(1) Q172EX-S2/Q172EX-S3 name of parts

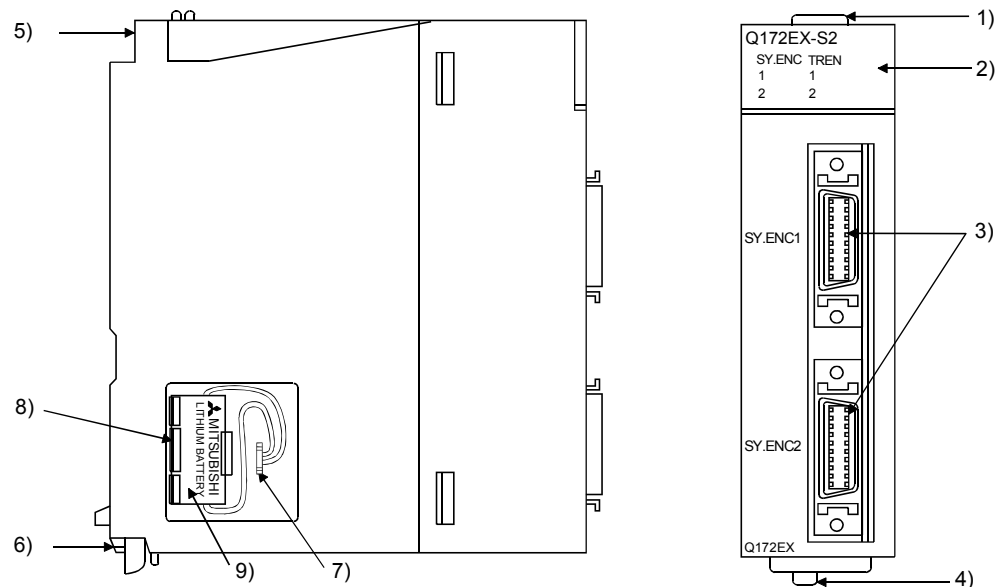

No.	Name	Application						
1)	Module fixing hook	Hook used to fix the module to the base unit. (Quick release installation)						
2)	Mode judging LED	Display the input status from the external equipment. <table border="1"> <thead> <tr> <th>LED</th> <th>Details</th> </tr> </thead> <tbody> <tr> <td>SY.ENC 1, 2</td> <td>Indicates to display the signal input status of each serial absolute synchronous encoder. (When the serial absolute synchronous encoder cable connected property, LED is turned on.)</td> </tr> <tr> <td>TREN 1, 2</td> <td>Indicates to display the signal status of tracking enable.</td> </tr> </tbody> </table>	LED	Details	SY.ENC 1, 2	Indicates to display the signal input status of each serial absolute synchronous encoder. (When the serial absolute synchronous encoder cable connected property, LED is turned on.)	TREN 1, 2	Indicates to display the signal status of tracking enable.
LED	Details							
SY.ENC 1, 2	Indicates to display the signal input status of each serial absolute synchronous encoder. (When the serial absolute synchronous encoder cable connected property, LED is turned on.)							
TREN 1, 2	Indicates to display the signal status of tracking enable.							
3)	SY. ENC connector	Input connector of the serial absolute synchronous encoder.						
4)	Module loading lever	Used to install the module to the base unit.						
5)	Module fixing screw hole	Hole for the screw used to fix to the base unit (M3×12 screw : Purchase from the other supplier)						
6)	Module fixing hook	Hook used to fix to the base unit.						
7)	Battery connector	For connection of battery lead wire.						
8)	Battery holder	Used to the Install the Battery (A6BAT/MR-BAT) to the holder.						
9)	Battery (A6BAT/MR-BAT)	For Serial absolute synchronous encoder battery backup.						

2 SYSTEM CONFIGURATION

(2) Performance specifications

(a) Module specifications

Item	Specifications	
	Q172EX-S2	Q172EX-S3
Memory for data exchange	None	Provided
Number of I/O occupying points	32 points(I/O allocation: Intelligent, 32 points)	
Internal current consumption(5VDC)[A]	0.07	
Exterior dimensions [mm(inch)]	98(H)×27.4(W)×90(D) (3.86(H)×1.08(W)×3.54(D))	
Mass [kg]	0.15	

(b) Tracking enable signal input

Item	Specifications	
Number of input points	Tracking enable signal : 2 points	
Input method	Sink/Source type	
Isolation method	Photocoupler	
Rated input voltage	12/24VDC	
Rated input current	12VDC 2mA/24VDC 4mA	
Operating voltage range	10.2 to 26.4VDC (12/24VDC +10/ -15%, ripple ratio 5% or less)	
ON voltage/current	10VDC or more/2.0mA or more	
OFF voltage/current	1.8VDC or less/0.18mA or less	
Input resistance	Approx. 5.6kΩ	
Response time	OFF to ON	0.4ms/0.6ms/1ms
	ON to OFF	(CPU parameter setting, Default 0.4ms)
Common terminal arrangement	1 point/common (Common terminal: TREN.COM)	
Indicates to display	ON indication (LED)	

2 SYSTEM CONFIGURATION

(c) Serial absolute synchronous encoder input

Item	Specifications
Applicable signal types	Differential-output type : (SN75C1168 or equivalent)
Transmission method	Serial communications
Synchronous method	Counter-clock-wise (viewed from end of shaft)
Communication speed	2.5Mbps
Applicable types	Q170ENC
Position detection method	Absolute (ABS) method
Resolution	262144PLS/rev (18bit)
Number of modules	2/module
External connector type	20 pin connector
Applicable connector for the external connection	Q170ENC CNS (Optional)
Applicable wire	MB14B0023 12Pair
Connecting cable	Q170ENC CBL□M (□=cable length 2m(6.56ft.), 5m(16.40ft.), 10m(32.81ft.), 20m(65.62ft.), 30m(98.43ft.), 50m(164.04ft.)) ^(Note-1)
Cable length	Up to 50m (164.04ft.)
Back up the absolute position.	Depends on A6BAT/MR-BAT.
Battery service life time (value in actual)	12000[h], (Example of encoders×2, Ambient temperature 40°C (104°F)) 24000[h], (Example of encoders×1, Ambient temperature 40°C (104°F))

(Note-1) : You can use these cables when the tracking enable signal is not used.

When the tracking enable signal is used, fabricate the cable on the customer side.

(Note-2) : Serial absolute synchronous encoder (MR-HENC) for Q173CPU(N)/Q172CPU(N) can also be used. Refer to the "Q173CPU(N)/Q172CPU(N) Motion controller User's Manual (IB-0300040)" for details of MR-HENC.

(3) Select to number of the synchronous encoder modules

Synchronous encoders are available in voltage output type(incremental), differential output type(incremental) and serial absolute output type(Q170ENC). Q172EX can be connected to only serial absolute output type(Q170ENC). When using the incremental synchronous encoder of voltage output type or differential output type, must be used Q173PX. (The synchronous encoders are used only in the SV22 virtual mode.)

In addition, the usable numbers of synchronous encoders differ depending on the modules.

The following number of serial absolute synchronous encoders and incremental synchronous encoders combined can be used.

Motion CPU module	Synchronous encoder
Q173HCPU	Up to 12 modules (Q172EX: Up to 6 modules)
Q172HCPU	Up to 8 modules (Q172EX: Up to 4 modules)

• Tracking enable signal

Tracking enable signal of Q172EX is used as a high-speed reading function. It cannot be used, as the input start signal which start the input form serial absolute synchronous encoders.

When using the inputs start signal which start the input from synchronous encoder, must be used Q173PX. (Type of synchronous encoder is voltage output(incremental)or differential output(incremental).)

The external input signal of the synchronous encoder is indicated below.

External input signal of the synchronous encoder	Item	Number of points on one Q172EX
Tracking enable signal input	High-speed reading function	2 points

(4) Connection of synchronous encoder interface module.

(a) Connection with serial absolute synchronous encoder (Q170ENC)

Use the SY.ENC connector at the Q172EX module front to connect the serial absolute synchronous encoder (Q170ENC).

When tracking enable signal is not used, use the Q170ENCCBL□M encoder cable between the serial absolute synchronous encoder (Q170ENC) and SY.ENC connector.

The following pin layout of the Q172EX SY.ENC connector viewed from the front.

The pin layout and connection description of the SY.ENC connector are described below.

SY.ENC connector

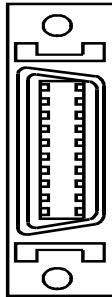

Pin No.	Signal name	Pin No.	Signal name
1	LG	11	LG
2	LG	12	LG
3	LG	13	No connect
4	TREN	14	TREN.CO
5	No connect	15	No connect
6	MD	16	MDR
7	MR	17	MRR
8	No connect	18	P5
9	BAT	19	P5
10	P5	20	P5

Applicable connector model names
 10120-3000VE connector
 10320-52F0-008 connector cover (3M make)

(Note) : Do not connect a wire to MD(6Pin), MDR(16Pin).

(b) Interface with external equipment

The interface between the SY.ENC connector and external equipment is described below.

1) Wiring precautions

Ensure the connector lock after connecting the connector.

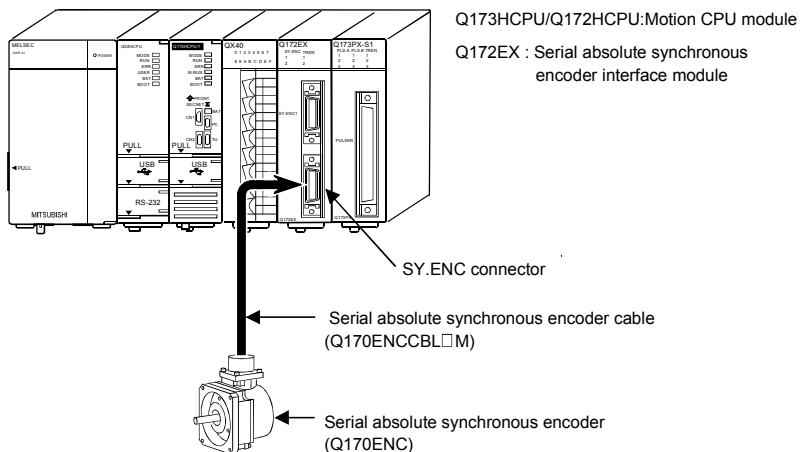

2 SYSTEM CONFIGURATION

(5) Interface between SY.ENC connector and external equipment

Input or Output	Signal name	Pin No.	Wiring example	Internal circuit	Specification	Description
		SY.ENC connector				
Input	MR	7			<ul style="list-style-type: none"> • Transmission method: serial communications • Position detection method: absolute 	
	MRR	17				
	P5	10 18 19 20				
	LG	1 2 3 11 12				
	BAT	9				
	TREN (Note)	4				
	TREN. COM (Note)	14				
	SD	plate				

(Note) : As for the connection to power line (TREN, TREN.COM), both "+" and "-" are possible.

CAUTION

- Always use a shield cable for connection of the SY.ENC connector and external equipment, and avoid running it close to or bundling it with the power and main circuit cables to minimize the influence of electromagnetic interface. (Separate them more than 200mm (0.66 ft.) away.)
- Connect the shield wire of the connection cable to the FG terminal of the external equipment.
- When increasing the cable length, use the cable 50m(164.04ft.) or less. Note that the cable should be run in the shortest possible distance to avoid induced noise.
- Always wire the cables when power is off. Not doing so may damage the circuit of modules.
- Wire the cable correctly. Wrong wiring may damage the internal circuit.

2 SYSTEM CONFIGURATION

(6) Details of encoder cable connections

(a) When not using tracking enable signal (Note-1)

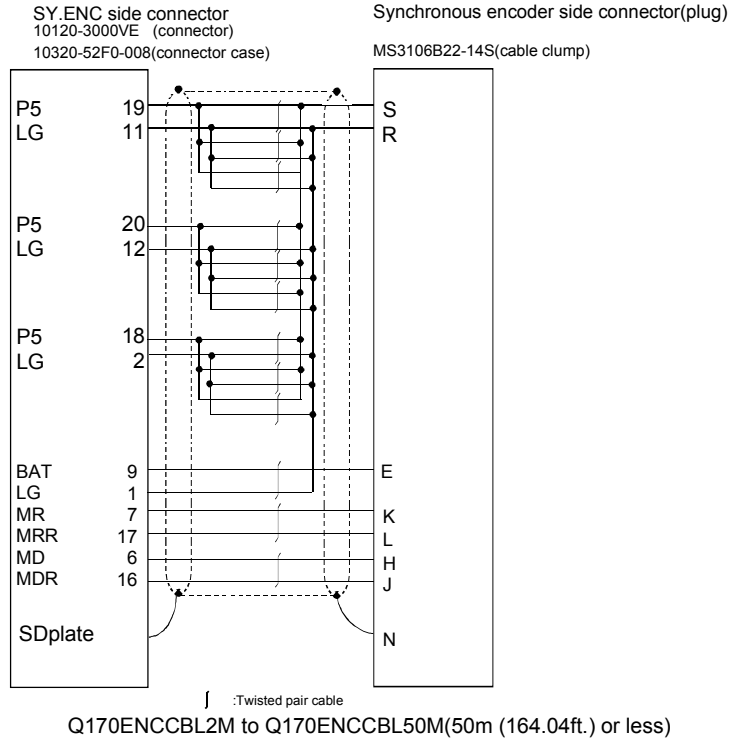

(b) When using tracking enable signal (Note-1), (Note-2)

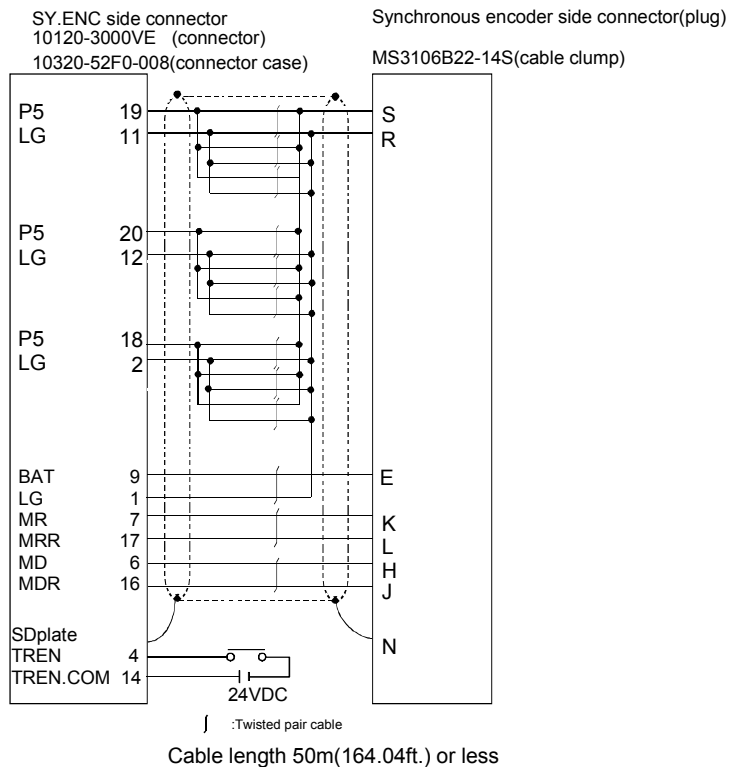

(Note-1) : Be sure to use a wire model name AWG24.

(Note-2) : When using tracking enable signal, fabricate the encoder cable by customer side.

2 SYSTEM CONFIGURATION

(7) Connection of the battery

This section describes the battery specifications, handling precautions and installation of the Q172EX.

(a) Specifications

The specifications of the battery for memory back-up are shown in the table below.

Battery Specifications

Item	Model name	A6BAT/MR-BAT
Classification		Manganese dioxide lithium primary battery
Normal voltage [V]		3.6
Battery discharge capacity [mAh]		1600
Battery warranty period		5 years
Lithium content [g]		0.48
Applications		For backup absolute positioning data of the serial absolute synchronous encoder (Q170ENC)
Exterior dimensions [mm(inch)]		φ 16(0.63) × 30(1.18)

(Note) : The 44th Edition of the IATA (International Air Transportation Association) Dangerous Goods Regulations was effected in January 1st, 2003 and administered immediately.

In this edition, the provisions relating to lithium and lithium ion batteries have been revised to strengthen regulations on the air transportation of battery.

This battery is not dangerous goods (not class 9). Therefore, these batteries of 24 units or less are not subject to the regulations.

These batteries more than 24 units require packing based on Packing Instruction 903.

If you need the self-certification form for the battery safety test, contact Mitsubishi.

For more information, contact Mitsubishi.

(b) Battery replacement

For Battery replacement procedure, refer to section 6.4.2.

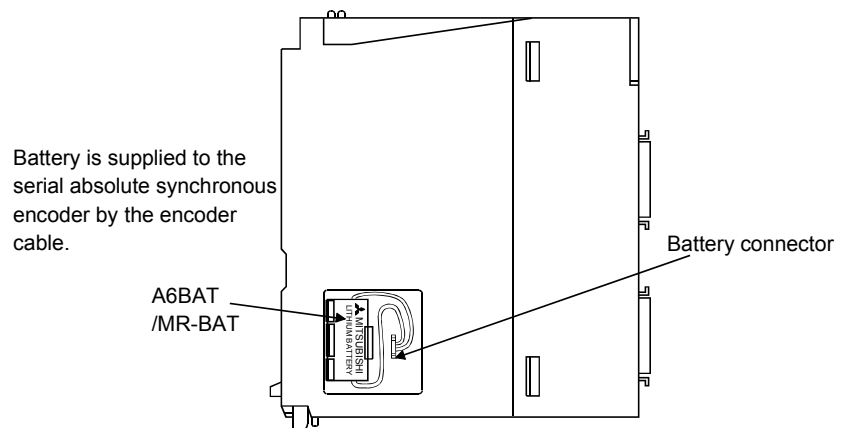

2 SYSTEM CONFIGURATION

(c) Battery service life time

	Battery service life time	
	Guaranteed time(MIN) [h]	Actual time(TYP) [h]
Q170ENC 1 pcs.	8000	24000
Q170ENC 2 pcs.	4000	12000

CAUTION

- Do not short a battery.
- Do not charge a battery.
- Do not disassemble a battery.
- Do not burn a battery.
- Do not overheat a battery.
- Do not solder the battery terminals.

2 SYSTEM CONFIGURATION

2.4.6 Q173PX Manual pulse generator interface module

Q173PX receive external signals required for Manual pulse generator and Incremental synchronous encoder (Voltage-output/Open collector type/Differential-output type).

(1) Q173PX/Q173PX-S1 name of parts

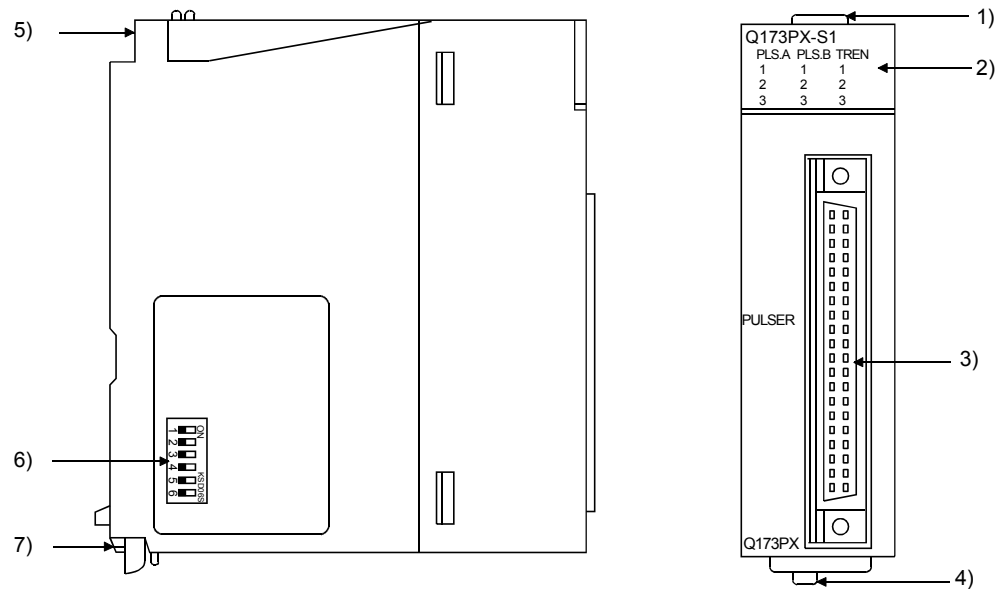

No.	Name	Application						
1)	Module fixing hook	Hook used to fix the module to the base unit. (Quick release installation)						
2)	Mode judging LED	Display the input status from the external equipment. <table border="1" style="margin: 10px auto;"> <thead> <tr> <th>LED</th> <th>Details</th> </tr> </thead> <tbody> <tr> <td>PLS.A 1 to 3 PLS.B 1 to 3</td> <td>Input signal status of the Manual pulse generator/Incremental synchronous encoder phases A and B</td> </tr> <tr> <td>TREN 1 to 3</td> <td>Tracking enable signal</td> </tr> </tbody> </table> <p>This LED is not turned on if it is not set the Q173PX in the system settings.</p>	LED	Details	PLS.A 1 to 3 PLS.B 1 to 3	Input signal status of the Manual pulse generator/Incremental synchronous encoder phases A and B	TREN 1 to 3	Tracking enable signal
LED	Details							
PLS.A 1 to 3 PLS.B 1 to 3	Input signal status of the Manual pulse generator/Incremental synchronous encoder phases A and B							
TREN 1 to 3	Tracking enable signal							
3)	PULSER connector	Input connector of the Manual pulse generator/Incremental synchronous encoder.						
4)	Module loading lever	Used to load the module to the base unit.						
5)	Module fixing screw hole	Hole for the screw used to fix to the base unit (M3×12 screw : Purchase from the other supplier)						

2 SYSTEM CONFIGURATION

No.	Name	Application
6)	Dip switches (Note-1)(Note-2)  (Shipped from the factory in OFF position)	Dip switch 1 Detection setting of TREN1 signal SW1 SW2 OFF OFF ON ON ON OFF OFF ON
		Dip switch 2 TREN is detected when TREN signal turns off to on. TREN is detected when TREN signal turns on to off.
		Dip switch 3 Detection setting of TREN2 signal SW3 SW4 OFF OFF ON ON ON OFF OFF ON
		Dip switch 4 TREN is detected when TREN signal turns off to on. TREN is detected when TREN signal turns on to off.
		Dip switch 5 Detection setting of TREN3 signal SW5 SW6 OFF OFF ON ON ON OFF OFF ON
		Dip switch 6 TREN is detected when TREN signal turns off to on. TREN is detected when TREN signal turns on to off.
7)	Module fixing hook	Hook used to fix to the base unit.

(Note-1) : When using the Q173PX-S1 only.

(Note-2) : The function is different according to the operating system software installed.

POINTS

The lighting condition of input display LED is shown below.

(1) PLS.A 1 to 3, PLS.B 1 to 3

- Q173PX is set on the system setting display of SW6RN-GSV□P.
- All axes servo ON command (M2042) turned on.
- Manual pulse generator enable flag (M2051, M2052, M2053) turned on.
- Manual pulse generator signal is input.

(2) TREN 1 to 3

- Q173PX is set on the system setting display of SW6RN-GSV□P.
- Tracking signal is input.

2 SYSTEM CONFIGURATION

(2) Performance specifications

(a) Module specifications

Item	Specifications	
	Q173PX	Q173PX-S1
Memory for data exchange	None	Provided
Number of I/O occupying points	32 points(I/O allocation: Intelligent, 32 points)	
Internal current consumption(5VDC)[A]	0.11	
Exterior dimensions [mm(inch)]	98(H)×27.4(W)×90(D) (3.86(H)×1.08(W)×3.54(D))	
Mass [kg]	0.15	

(b) Tracking enable signal input

Item	Specifications	
Number of input points	Tracking enable signal : 3 points	
Input method	Sink/Source type	
Isolation method	Photocoupler	
Rated input voltage	12/24VDC	
Rated input current	12VDC 2mA/24VDC 4mA	
Operating voltage range	10.2 to 26.4VDC (12/24VDC +10/ -15%, ripple ratio 5% or less)	
ON voltage/current	10VDC or more/2.0mA or more	
OFF voltage/current	1.8VDC or less/0.18mA or less	
Input resistance	Approx. 5.6kΩ	
Response time	OFF to ON	0.4ms/0.6ms/1ms (CPU parameter setting, Default 0.4ms)
	ON to OFF	
Common terminal arrangement	1 point/common(Common contact: TREN.COM)	
Indicates to display	ON indication(LED)	

2 SYSTEM CONFIGURATION

(c) Manual pulse generator/Incremental synchronous encoder input

Item		Specifications
Number of modules		3/module
Voltage-output/ Open collector type	High-voltage	3.0 to 5.25VDC
	Low-voltage	0 to 1.0VDC
Differential-output type (26LS31 or equivalent)	High-voltage	2.0 to 5.25VDC
	Low-voltage	0 to 0.8VDC
Input frequency		Up to 200kpps (After magnification by 4)
Applicable types		Voltage-output type/Open-collector type (5VDC), Recommended product: MR-HDP01 Differential-output type: (26LS31 or equivalent)
External connector type		40 pin connector
Applicable wire size		0.3mm ²
Applicable connector for the external connection		A6CON1(Attachment) A6CON2, A6CON3(Optional)
Cable length	Voltage-output/ Open collector type	30m (98.43ft.)
	Differential-output type	(Open collector type: 10m (32.81ft.))

(3) Connection of manual pulse generator

Manual pulse generators are available in voltage output/open collector type and differential output type. Since these types differ in connection method, design according to the connection method of section 2.4.6 (5).

In addition the usable numbers of manual pulse generator which can be used with each CPU modules are up to 3 modules.

Motion CPU module	Manual pulse generator
Q173HCPU	Up to 3 modules (Up to 1 module)
Q172HCPU	

(4) Connection of incremental synchronous encoder

Incremental synchronous encoders are available in voltage output/Open collector type and differential output type. Since these types differ in connection method, design according to the connection method of section 2.4.6 (5).

Serial type absolute synchronous encoder (Q170ENC) not connected to Q173PX. Then connect to Q172EX.

In addition, the usable numbers of synchronous encoders differ depending on the modules.

The following number of serial absolute synchronous encoders and incremental synchronous encoders combined can be used.

Motion CPU module	Synchronous encoder
Q173HCPU	Up to 12 modules (Q173PX: Up to 4 modules)
Q172HCPU	Up to 8 modules (Q173PX: Up to 3 modules)

• Tracking enable signal

Tracking enable signal of Q173PX is used to start the input from incremental synchronous encoders.

The external input signal of the incremental synchronous encoder is indicated below.

This signal is used as the input start signal or high-speed reading function from incremental synchronous encoder.

External input signal of the incremental synchronous encoder	Item	Number of points on one Q173PX
Tracking enable signal input	Input start function from incremental synchronous encoder	Each 1 point (Total 3 points)

(5) Connection of manual pulse generator interface module
 (a) The pin layout of the PULSER connector

Use the PULSER connector at the Q173PX module front to connect the manual pulse signals, incremental synchronous encoder signals.

The following pin layout of the Q173PX PULSER connector viewed from the front.

The pin layout and connection description of the PULSER connector are described below.

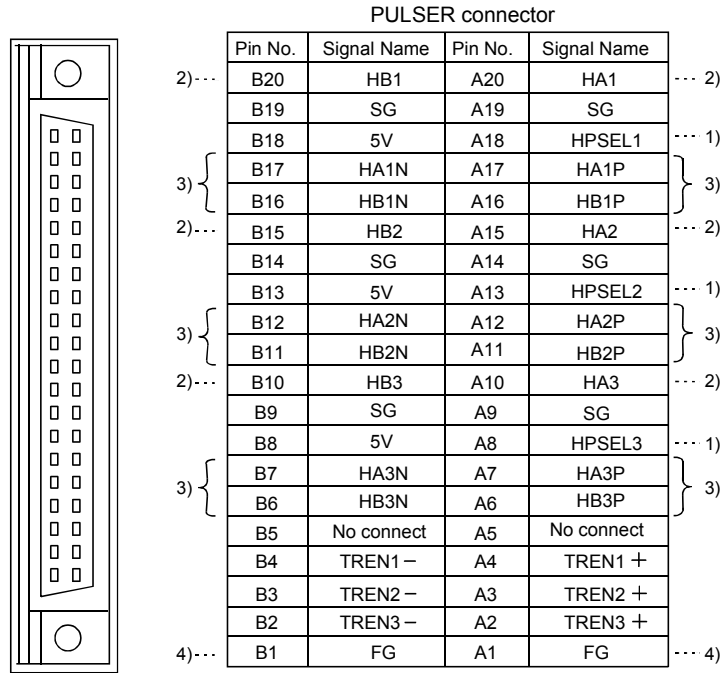

Applicable connector model name

- A6CON1 type soldering type connector
 - FCN-361J040-AU connector (FUJITSU TAKAMISAWA COMPONENT LIMITED)
 - FCN-360C040-B connector cover
 - A6CON2 type Crimp-contact type connector
 - A6CON3 type Pressure-displacement type connector
- } (Attachment)
 } (Optional)

- 1) : Input type from manual pulse generator/incremental synchronous encoder switched by HPSEL□.
 Not connection : Voltage-output type/open collector type.
 HPSEL□-SG connection : Differential-output type.
 (Switching is possible for each input 1 to 3)
- 2) : Voltage output/open collector type
 Connect the A-phase signal to HA1P/HA2P/HA3P, and the B-phase signal to HB1P/HB2P/HB3P.
- 3) : Differential output type
 Connect the A-phase signal to HA1P/HA2P/HA3P, and the A-phase inverse signal to HA1N/HA2N/HA3N.
 Connect the B-phase signal to HB1P/HB2P/HB3P, and the B-phase inverse signal to HB1N/HB2N/HB3N.
- 4) : Connect the shield cable between manual pulse generator/incremental synchronous encoder and Q173PX at the FG signal.
- 5) : Connector/terminal block conversion modules cannot be used.

2 SYSTEM CONFIGURATION

(b) Interface between PULSER connector and manual pulse generator (Differential output type)/Incremental synchronous encoder

Interface between Manual pulse generator (Differential output type)/ Incremental synchronous encoder

Input or Output	Signal name		Pin No.			Wiring example	Internal circuit	Specification	Description
			PULSER connector						
			Voltage-Output type						
1	2	3							
Input	Manual pulse generator, phase A	A+ HA□P	A17	A12	A7		<ul style="list-style-type: none"> Rated input voltage 5.5VDC or less HIGH level 2.0 to 5.25VDC LOW level 0.8VDC or less 26LS31 or equivalent 	For connection manual pulse generator Phases A, B <ul style="list-style-type: none"> Pulse width 20μs or more 5μs or more 5μs or more (Duty ratio: 50%±25%) Rise, fall time ...1μs or less. Phase difference 	
		A- HA□N	B17	B12	B7				
	Manual pulse generator, phase B	B+ HB□P	A16	A11	A6				B- HB□N
	Select type signal	HPSEL□	A18	A13	A8	(Note-2)			
Power supply	P5 ^(Note-1)		B18	B13	B8				
	SG		A19 B19	A14 B14	A9 B9				

(Note-1) : The 5V(P5)DC power supply from the Q173PX must not be connected if a separated power supply is used as the Manual pulse generator/Incremental synchronous encoder power supply. Use a 5V stabilized power supply as a separated power supply. Any other power supply may cause a failure.

(Note-2) : Connect HPSEL□ to the SG terminal if the manual pulse generator (differential output type) /incremental synchronous encoder is used.

2 SYSTEM CONFIGURATION

(c) Interface between PULSER connector and manual pulse generator (Voltage output/Open collector type)/ Incremental synchronous encoder.

Interface between Manual pulse generator (Voltage-output/Open collector type)/Incremental synchronous encoder

Input or Output	Signal name	Pin No.			Wiring example	Internal circuit	Specification	Description
		PULSER connector						
		Voltage-Output type						
1	2	3						
Input	Manual pulse generator, phase A HA□	A20	A15	A10		<ul style="list-style-type: none"> Rated input voltage 5.5VDC or less HIGH level 3 to 5.25VDC/ 2mA or less LOW level 1VDC or less/ 5mA or more 	For connection manual pulse generator Phases A, B <ul style="list-style-type: none"> Pulse width 20μs or more Rise, fall time •••1μs or less Phase difference 	
	Manual pulse generator, phase B HB□	B20	B15	B10				
	Select type signal HPSEL□	A18	A13	A8				
Power supply	P5 ^(Note)	B18	B13	B8				
	SG	A19 B19	A14 B14	A9 B9				

(Note) : The 5V(P5)DC power supply from the Q173PX must not be connected if a separated power supply is used as the Manual pulse generator/Incremental synchronous encoder power supply. Use a 5V stabilized power supply as a separated power supply. Any other power supply may cause a failure.

(d) Interface between PULSER connector and tracking enable signal

Interface between tracking enable signal

Input or Output	Signal name	Pin No.			Wiring example	Internal circuit	Specification	Description
		PULSER connector						
		1	2	3				
Input	Tracking enable (Note)	TREN□+	A4	A3	A2			Tracking enable signal input.
		TREN□-	B4	B3	B2			

(Note) : As for the connection to tracking enable (TREN□+, TREN□-), both "+" and "-" are possible.

2 SYSTEM CONFIGURATION

(6) Connection examples of manual pulse generator

Connection of manual pulse generator
(Voltage-output/Open collector type)

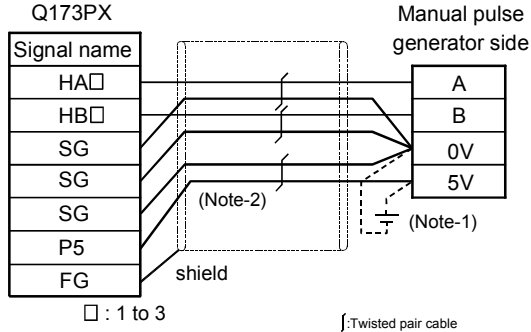

Connection of manual pulse generator
(Differential-output type)

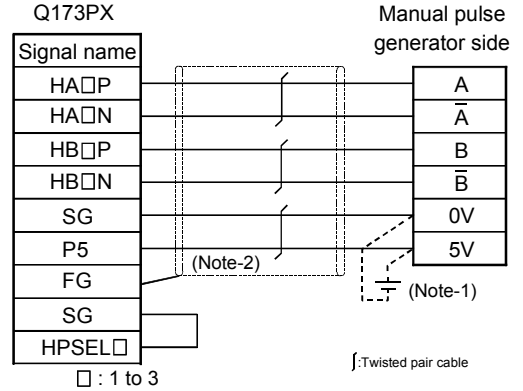

(Note-1) : The 5V(P5)DC power supply from the Q173PX must not be connected if a separated power supply is used as the Manual pulse generator/Incremental synchronous encoder power supply.

Use a 5V stabilized power supply as a separated power supply. Any other power supply may cause a failure.

(Note-2) : Connect HPSEL□ to the SG terminal if the manual pulse generator (differential output type/incremental synchronous encoder) is used.

! CAUTION

- If a separate power supply is used as the manual pulse generator/incremental synchronous encoder power supply, use a 5V stabilized power supply. Any other power supply may cause a failure.

2 SYSTEM CONFIGURATION

2.4.7 Manual pulse generator/Serial absolute synchronous encoder

(1) Table of the Manual pulse generator specifications

Item	Specifications
Model name	MR-HDP01
Ambient temperature	-10 to 60°C(14 to 140°F)
Pulse resolution	25PLS/rev(100 PLS/rev after magnification by 4)
Output method	Voltage-output(power supply voltage -1V or more), Output current = Up to 20mA
Power supply voltage	4.5 to 13.2VDC
Current consumption [mA]	60
Life time	1,000,000 revolutions (at 200r/min)
Permitted axial loads	Radial load : Up to 19.6N
	Thrust load : Up to 9.8N
Mass [kg]	0.4
Number of max. revolution	Instantaneous Up to 600r/min. normal 200r/min
Pulse signal status	2 signals : A phase, B : phase, 90° phase difference
Friction torque	0.1N/m(at 20°C (68°F))

2 SYSTEM CONFIGURATION

(2) Table of the Serial absolute synchronous encoder specifications

Item	Specifications
Model name	Q170ENC ^(Note-1)
Ambient temperature	-5 to 55°C(23 to 131°F)
Resolution	262144PLS/rev
Transmission method	Serial communications (Connected to Q172EX-S2/-S3)
Direction of increasing addresses	CCW(viewed from end of shaft)
Protective construction	Dustproof/Waterproof (IP65: Except for the shaft-through portion.)
Permitted speed at power ON	3600r/min
Permitted speed at power OFF <small>(Note-2)</small>	500r/min
Permitted axial loads	Radial load : Up to 19.6N
	Thrust load : Up to 9.8N
Runout at input shaft tip	0.02mm(0.00079 inch) or less, 15mm(0.59 inch) from tip
Recommended coupling	Bellows coupling
Permitted angular acceleration	40000rad/s ²
Internal current consumption [A]	0.2
Mass [kg]	0.6
Connecting cable	Q170ENCCBL□M □=Cable length: 2m(6.56ft.), 5m(16.40ft.), 10m(32.81ft.), 20m(65.62ft.), 30m(98.43ft.), 50m(164.04ft.)
Communications method	Differential driver/receiver conforming to RS422A
Transmission distance	Up to 50m(164.04ft.)

(Note-1): It is possible to use only by Q172EX-S2/-S3.

When "o-ring" is required, please purchase separately by customers.

(Note-2): If it exceeds a permitted speed at power OFF, a position displacement is generated.

2 SYSTEM CONFIGURATION

2.4.8 A31TU-D3□/A31TU-DN□ Teaching unit (Japanese version only)

Teaching unit A31TU-D3□/A31TU-DN□ can be easily set the teaching of positioning point, each parameter settings, creation of servo program, servo monitor, servo test, and so on without the peripheral devices. (Motion CPU module Q173HCPU-T/ Q172HCPU-T is usable only. Refer to the A31TU-D Teaching Unit Operating Manual for the usable operating system software and version.)

(1) Selection of the teaching unit

There are no deadman switch and emergency stop terminal for the external safety circuit in a A31TU-DN□.

Use the A31TU-D3□ to raise safety more by the deadman switch or external safety circuit ^(Note).

Refer to the following table for selection of the teaching unit.

Item	A31TU-D3□	A31TU-DN□
3-position deadman switch	Provided (Normally open contact, double contact) Normally open contact is connected by gripping/releasing this switch.	—
Emergency stop switch (Push lock return reset type)	Provided (Normally closed contact, double contact) Normally closed contact is released by pushing switch. Normally closed contact is connected by turning to the right this switch.	Provided (Normally closed contact, double contact) Normally closed contact is released by pushing switch. Normally closed contact is connected by turning to the right this switch.
Terminal for external safety circuit	Provided (Emergency stop switch × 2, Deadman switch × 2, Emergency stop input to Motion CPU × 1)	—
Emergency stop input to Motion CPU	Connect to the external safety circuit. (Normally closed contact input) The emergency stop state of Motion CPU occurs by releasing the normally closed contact of external safety circuit.	Connect directly the emergency stop switch of A31TU-DN□. (Normally closed contact input) The emergency stop state of Motion CPU occurs by pushing the emergency stop switch of A31TU-DN□.
Connecting cable with Motion CPU	Q170TUD3CBL3M (Control panel connecting type)	Q170TUDNCBL3M (Control panel connecting type) Q170TUDNCBL03M-A (Direct connecting type)
Remark	It is used as the following cases. • When the deadman switch is used. • When the double contact raises safety by attaching the external safety circuit.	It is used as the following cases. • When the deadman switch is not used. • When the teaching unit is used with simple connecting.

2 SYSTEM CONFIGURATION

REMARK

External safety circuit

Construct the circuit (power supply OFF of servomotor, etc.) of parts which may occur machine breakdown and accidents due to abnormal operations outside of the Motion CPU in a fail-safe viewpoint, to avoid abnormal operations of whole system.

CAUTION

- If the teaching unit A31TU-D3□ is released during operation, the emergency stop state of Motion CPU occurs, and the servomotor becomes coasting state.

2 SYSTEM CONFIGURATION

(2) A31TU-D3□/ A31TU-DN□ Name of parts

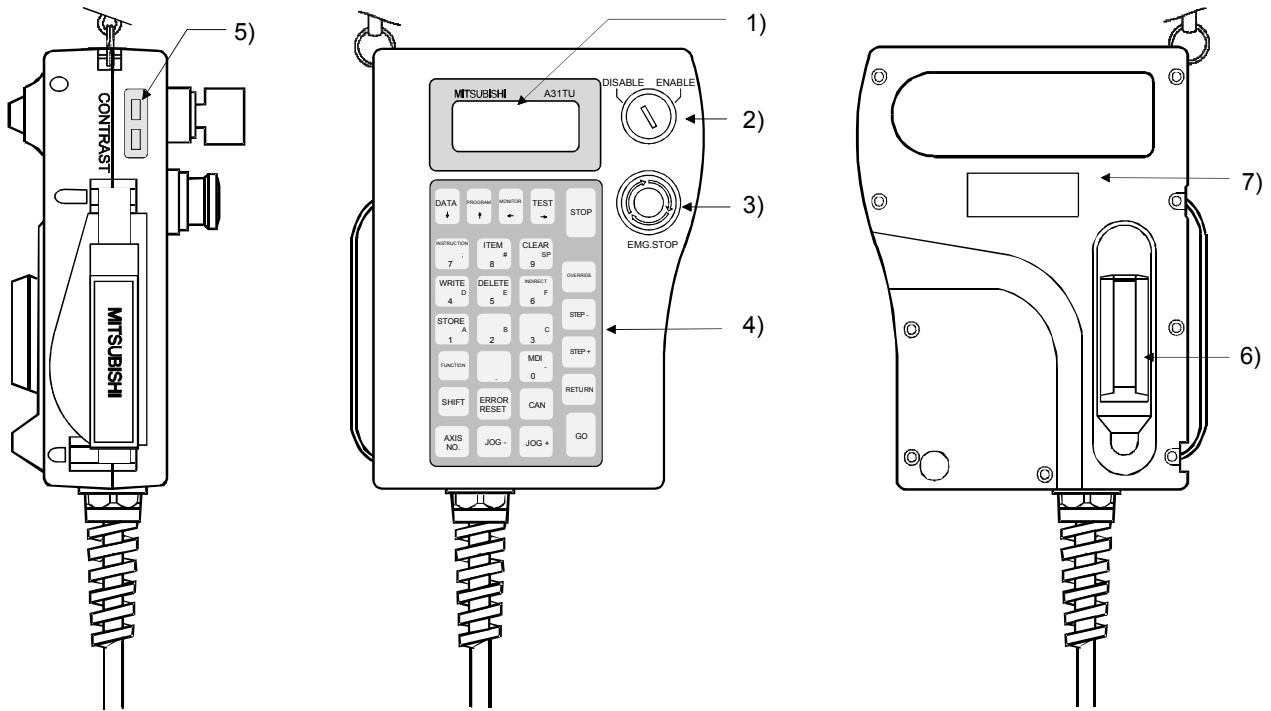

No.	Name	Application
1)	Display	4 lines × 16 characters LCD display (With back-lighted auto light off)
2)	DISABLE/ENABLE key select switch	Switch the operation of teaching unit to DISABLE/ENABLE
3)	Emergency stop switch EMG.STOP button	Input the emergency stop signal to the Motion CPU. The emergency stop state of Motion CPU occurs by pushing the switch, and the servomotor stops and becomes coasting state. The emergency stop state is released by turning to the right this switch.
4)	Operation keys	Operation key of the teaching unit
5)	Contrast adjusting switch	Adjust the contrast of display.
6)	3-position deadman switch (A31TU-D3□ only)	The emergency stop signal is input to the Motion CPU by the external safety circuit. The Motion CPU will be in the state which can be operated by holding the middle position of enable switch. The emergency stop state of Motion CPU occurs by gripping or releasing this switch, and the servomotor stops and becomes coasting state.
7)	Internal buzzer	Buzzer sounds at the operation key input or any alarm occurrence. (It is possible to switch off the buzzer at the key input by setting.)

2 SYSTEM CONFIGURATION

(3) Teaching unit specifications

Items		Specifications	
		A31TU-D3□	A31TU-DN□
Operation	Language	Japanese	
	Tact switch	28 keys for SV□	
	ENABLE/DISABLE switch	Operation enable/disable	
	Emergency stop switch	Push lock return reset type	
	Deadman switch	3-position switch	None
	Contrast adjusting switch	Shade/light	
Display method		4 lines × 16 characters LCD display	
Interface		Conforming RS-422	
Protective construction		IP54 equivalent	
Ambient temperature		0 to 40°C (32 to 104°F)	
5VDC power supply		Supplied from Motion CPU	
5VDC consumption current [A]		0.26	
Mass [kg]		1.74 (Including cable 5m (16.40ft.))	

POINTS
(1) The total extended distance of cable between the Motion CPU and teaching unit is within [30m(98.43ft.)] including the A31TU-D3□/A31TU-DN□ cable [5m(16.40ft.)]
(2) The teaching unit is shipped, a protection sheet is attached in the surface of the display and operation key to prevent the crack for conveyance. Remove a protection sheet to use. Operation and display check without removing a protection sheet are possible, however adhesives may remain in a teaching unit by secular change.
(3) When the servomotor is operated by the JOG feed, etc. using the teaching unit (A31TU-D3□) with deadman switch, operate it pushing the deadman switch at middle position. The emergency stop state of Motion CPU occurs by gripping or releasing this switch, and the servomotor stops and becomes coasting state.

(4) Connection between the teaching unit and Motion CPU

(a) Connection between the teaching unit (A31TU-D3□) and Motion CPU (Q173HCPU-T/Q172HCPU-T)

- 1) Connect the cable for teaching unit (Q170TUD3CBL3M) between the TU connector of Motion CPU (Q173HCPU-T/Q172HCPU-T) and control panel. (Refer to the exterior dimensions of "APPENDIX 1.3 Cable for the teaching unit" and "APPENDIX 2.7 Connector", when it is fit to the control panel.)
- 2) Connect the connector for external safety circuit (connector for emergency stop switch×2 sets, connector for deadman switch×2 sets and connector for emergency stop input to Motion CPU×1 set) to the external safety circuit.
- 3) Connect the teaching unit (A31TU-D3□) to the cable for teaching unit (Q170TUD3CBL3M) connected to the control panel.

2 SYSTEM CONFIGURATION

- 4) When the teaching unit (A31TU-D3□) is not used, connect the short-circuit connector for teaching unit (A31TUD3TM) to the control panel side connector of the cable for teaching unit (Q170TUD3CBL3M).

Connection example between the cable for teaching unit (Q170TUD3CBL3M) and external safety circuit is shown below.

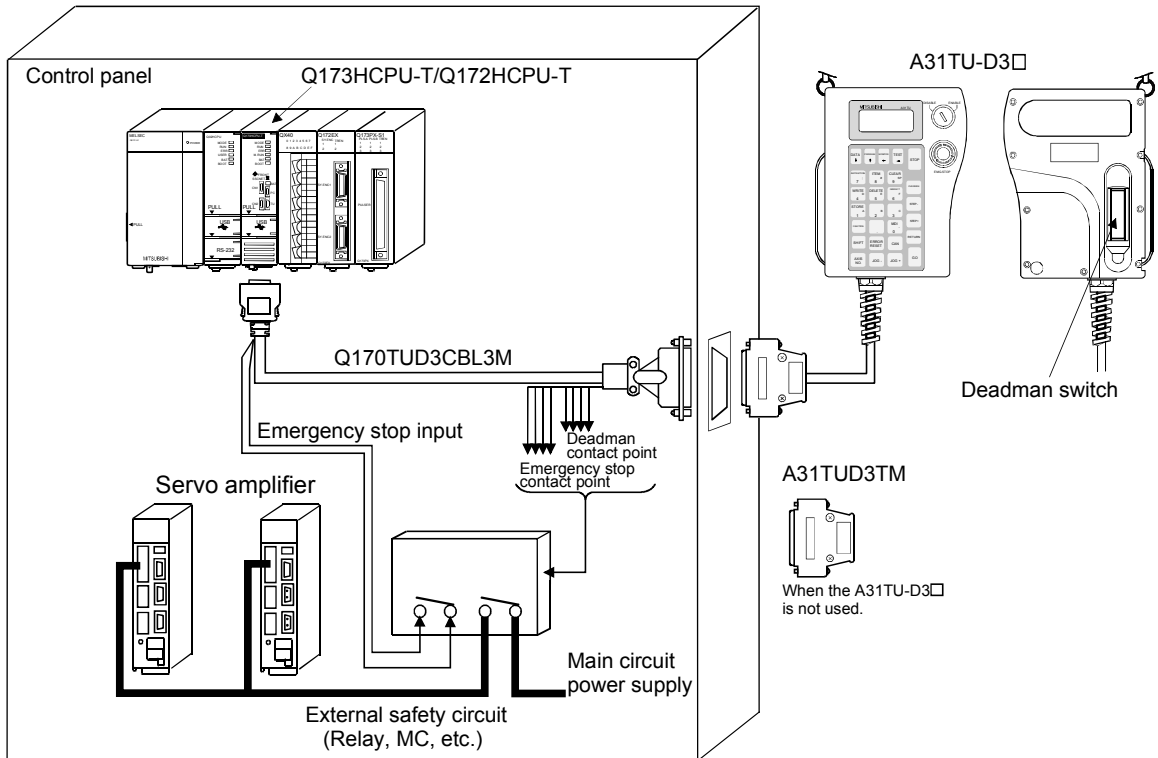

⚠ CAUTION

- Do not use it in the combination of the teaching unit without deadman switch (A31TU-DN□) and cable for teaching unit with deadman switch (Q170TUD3CBL3M). The protective function stops working.
- When the teaching unit (A31TU-D3□) is not used in the Motion CPU (Q173HCPU-T/Q172HCPU-T), connect the short-circuit connector for teaching unit (A31TUD3TM) to the control panel side connector of the cable for teaching unit (Q170TUD3CBL3M). If it is not connected, the emergency stop state of Motion CPU occurs, and the servomotor becomes coasting state.

2 SYSTEM CONFIGURATION

(b) Connection between the teaching unit (A31TU-DN□) and Motion CPU (Q173HCPU-T/Q172HCPU-T)

There are following two connecting method.

- When the connector is connected to the control panel.
- When the connector is connected directly in the control panel.

1) When the connector is connected to the control panel.

a) Connect the cable for teaching unit (Q170TUDNCBL3M) between the TU connector of Motion CPU (Q173HCPU-T/Q172HCPU-T) and control panel. (Refer to the exterior dimensions of "APPENDIX 1.3 Cable for the teaching unit" and "APPENDIX 2.7 Connector", when it is fit to the control panel.)

b) Connect the teaching unit (A31TU-DN□) to the cable for teaching unit (Q170TUDNCBL3M) connected to the control panel.

c) When the teaching unit (A31TU-DN□) is not used, connect the short-circuit connector for teaching unit (A31TUD3TM) to the control panel side connector of the cable for teaching unit (Q170TUDNCBL3M).

Connection example between the cable for teaching unit (Q170TUDNCBL3M) is shown below.

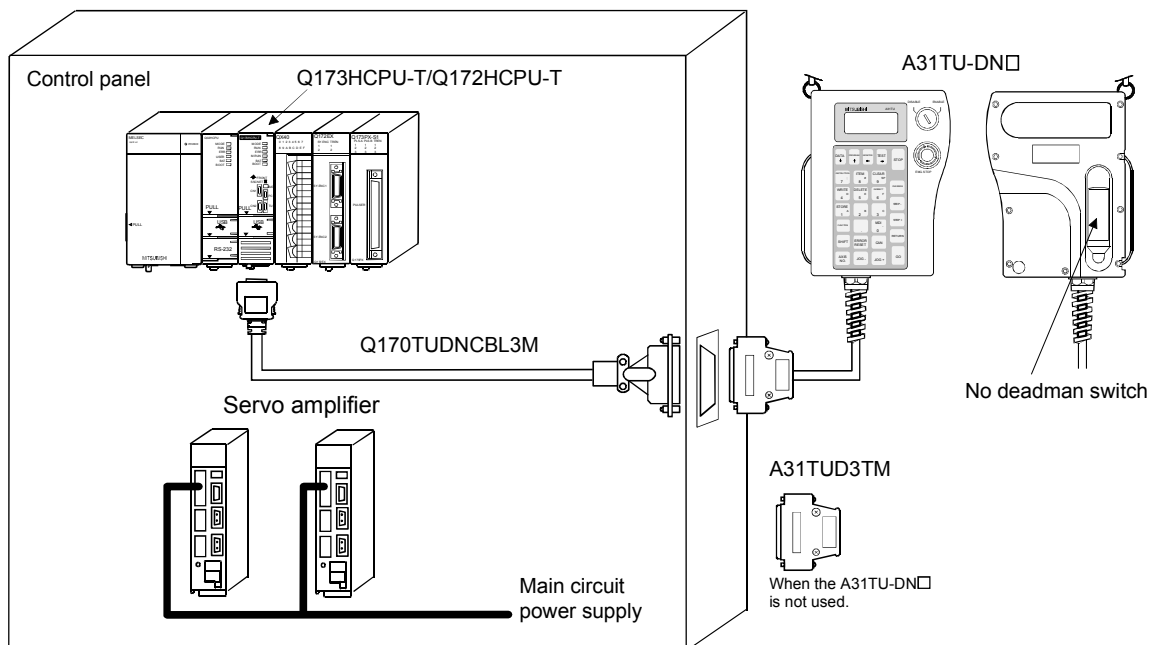

⚠ CAUTION

- Do not use it in the combination of the teaching unit with deadman switch (A31TU-D3□) and cable for teaching unit without deadman switch (Q170TUDNCBL3M). The protective function stops working.
- When the teaching unit (A31TU-DN□) is not used in the Motion CPU (Q173HCPU-T/Q172HCPU-T), connect the short-circuit connector for teaching unit (A31TUD3TM) to the control panel side connector of the cable for teaching unit (Q170TUDNCBL3M). If it is not connected, the emergency stop state of Motion CPU occurs, and the servomotor becomes coasting state.

2 SYSTEM CONFIGURATION

- 2) When the connector is connected directly in the control panel.
 - a) Connect the cable for teaching unit (Q170TUDNCBL03M-A) to the TU connector of Motion CPU (Q173HCPU-T/Q172HCPU-T) after connecting to the teaching unit (A31TU-DN□).
 - b) When the teaching unit (A31TU-DN□) is not used, connect the short-circuit connector for teaching unit (Q170TUTM) after removing a TU connector of cable for teaching unit (Q170TUDNCBL03M-A) from a TU connector of Motion CPU (Q173HCPU-T/Q172HCPU-T).

Connection example between the cable for teaching unit (Q170TUDNCBL03M-A) is shown below.

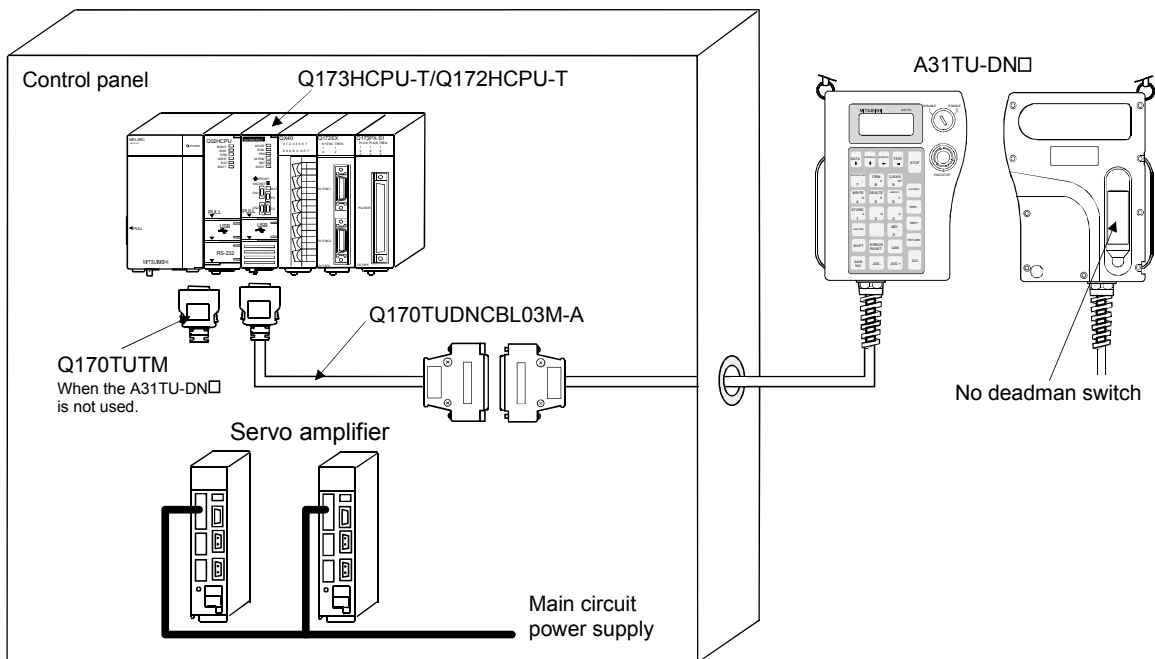

⚠ CAUTION

- Do not connect the A31TU-D3□ to the cable for teaching unit (Q170TUDNCBL03M-A). The protective function stops working.
- Be sure to fix the relay portion of a connector which has connected the cable for teaching unit (Q170TUDNCBL03M-A) with teaching unit (A31TU-DN□) so that impossible power is not applied for the connector of Motion CPU (Q173HCPU-T/Q172HCPU-T). A connector may be damaged.
- Do not pull a teaching unit (A31TU-DN□). A connector may be damaged.
- When a teaching unit (A31TU-DN□) is removed, first be sure to remove a TU connector of Motion CPU (Q173HCPU-T/Q172HCPU-T) so that impossible power is not applied for the connector. If a connector of teaching unit (A31TU-DN□) is removed connecting a TU connector of Motion CPU (Q173HCPU-T/Q172HCPU-T), a TU connector of Motion CPU (Q173HCPU-T/Q172HCPU-T) may be damaged.
- When the teaching unit (A31TU-DN□) is not used in the Motion CPU (Q173HCPU-T/Q172HCPU-T), connect the short-circuit connector for teaching unit (Q170TUTM) after removing a TU connector of cable for teaching unit (Q170TUDNCBL03M-A) from a TU connector of Motion CPU (Q173HCPU-T/Q172HCPU-T). If it is not connected, the emergency stop state of Motion CPU occurs, and the servomotor becomes coasting state.

2 SYSTEM CONFIGURATION

- (c) When not using a teaching unit (A31TU-D3□/A31TU-DN□)
Connect a short-circuit connector for teaching unit (Q170TUTM) to a TU connector of Motion CPU (Q173HCPU-T/Q172HCPU-T).

Connection example without teaching unit (A31TU-D3□/A31TU-DN□) is shown below.

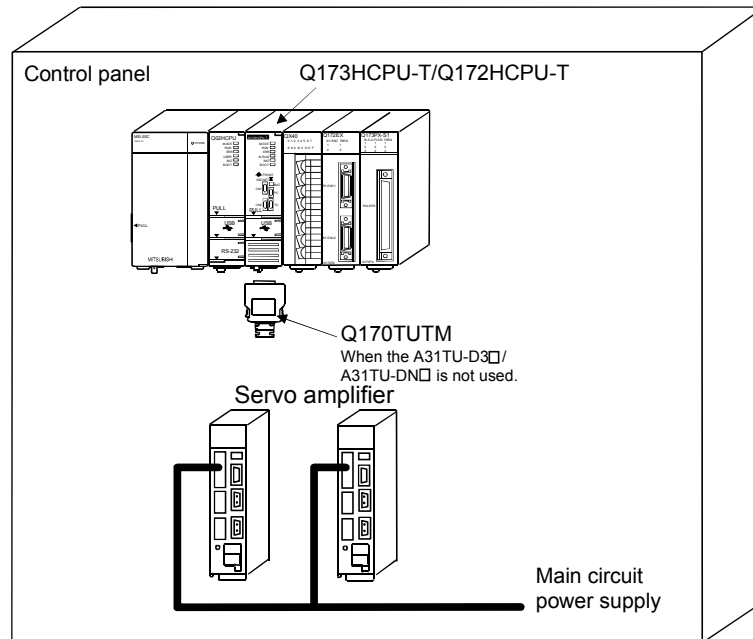

⚠ CAUTION

- When the teaching unit (A31TU-D3□/A31TU-DN□) is not used in the Motion CPU (Q173HCPU-T/Q172HCPU-T), connect the short-circuit connector for teaching unit (Q170TUTM) to a TU connector of Motion CPU (Q173HCPU-T/Q172HCPU-T). If it is not connected, the emergency stop state of Motion CPU occurs, and the servomotor becomes coasting state.

2 SYSTEM CONFIGURATION

2.4.9 SSCNET III cables and connection method

This section describes how to connect between the Motion CPU module and servo amplifiers.

Between the Motion CPU module and servo amplifiers is connected by SSCNET III cable. When using the Q172HCPU, only 1 SSCNET III cable for connection to servo amplifier can be used. (Connect to CN1.) When using the Q173HCPU, up to 2 SSCNET III cables for connection to servo amplifier can be used. (Connect to CN1 and CN2.)

Up to 16 servo amplifiers can be connected to 1 SSCNET III cable.

(However, when using the Q172HCPU, up to 8 servo amplifiers can be connected.)

(1) Connection between the Q173HCPU and servo amplifiers

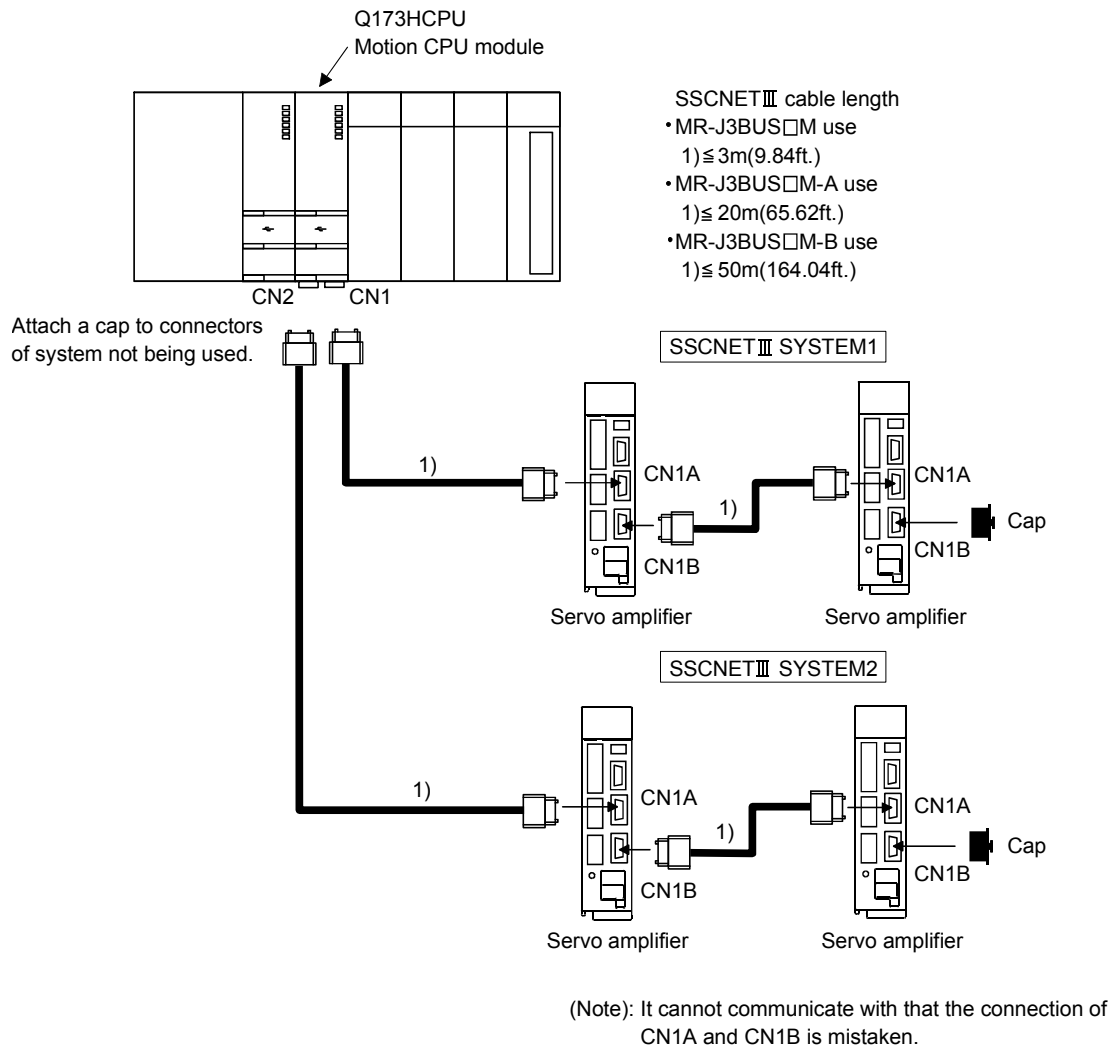

2 SYSTEM CONFIGURATION

(2) Connection between the Q172HCPU and servo amplifiers

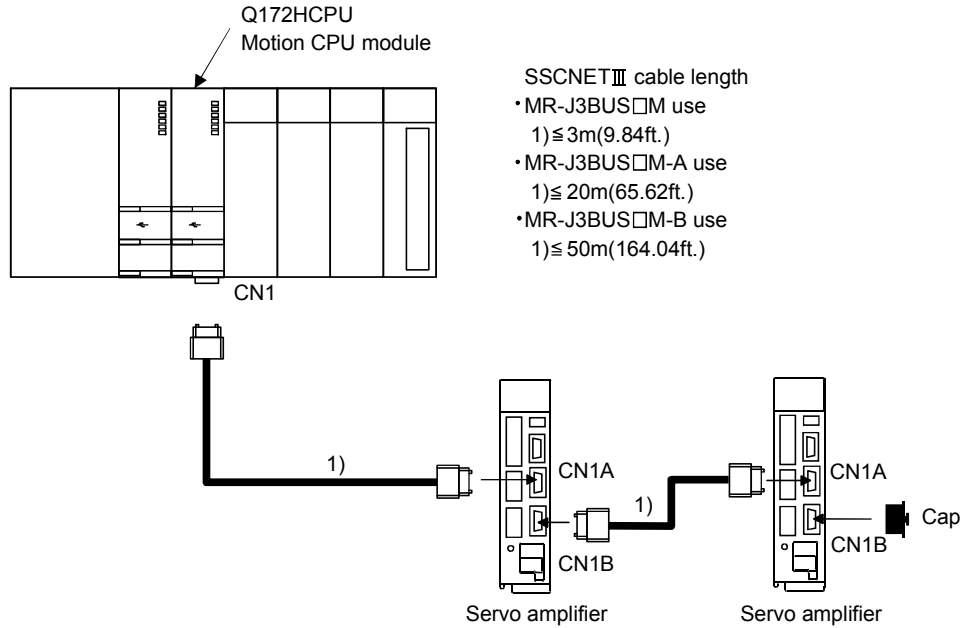

(Note): It cannot communicate with that the connection of CN1A and CN1B is mistaken.

List of SSCNETⅢ cable model name

Model name ^(Note)	Cable length	Description	
MR-J3BUS□M	0.15m(0.49ft.), 0.3m(0.98ft.), 0.5m(1.64ft.), 1m(3.28ft.), 3m(9.84ft.)	Standard code for inside panel	<ul style="list-style-type: none"> • Q173HCPU/Q172HCPU ↔ MR-J3-□B • MR-J3-□B ↔ MR-J3-□B
MR-J3BUS□M-A	5m(16.4ft.), 10m(32.81ft.), 20m(65.62ft.)	Standard cable for outside panel	
MR-J3BUS□M-B	30m(98.43ft.), 40m(131.23ft.), 50m(164.04ft.)	Long distance cable	

(Note) : □=cable length

2 SYSTEM CONFIGURATION

POINTS
(1) Be sure to connect SSCNETIII cable with the above connector. If the connection is mistaken, between the Motion controller and servo amplifier cannot be communicated.
(2) SSCNETIII connector is put a cap to protect light device inside connector from dust. For this reason, do not remove a cap until just before mounting SSCNETIII cable. Then, when removing SSCNETIII cable, make sure to put a cap.
(3) Be sure to keep a cap and the tube for protecting light code end of SSCNETIII cable in a plastic bag with a zipper of SSCNETIII cable to prevent them from becoming dirty.
(4) Do not remove the SSCNETIII cable while turning on the power supply of Motion CPU and servo amplifier. Do not see directly the light generated from the end of SSCNETIII cable. When the light gets into eye, may feel something is wrong for eye. (The light source of SSCNETIII cable corresponds to class1 defined in JISC6802 or IEC60825-1.)
(5) When exchanging the servo amplifier or Motion controller, make sure to put a cap on SSCNETIII connector. When asking repair of servo amplifier or Motion controller for some troubles, make also sure to put a cap on SSCNETIII connector. When the connector is not put a cap, the light device may be damaged at the transit. In this case, exchange and repair of light device is required.

(3) Cable specifications (a) MR-J3BUS□M

Model name Item	MR-J3BUS015M	MR-J3BUS03M	MR-J3BUS05M	MR-J3BUS1M	MR-J3BUS3M
Cable length [m(ft.)]	0.15(0.49)	0.3(0.98)	0.5(1.64)	1(3.28)	3(9.84)

(b) MR-J3BUS□M-A

Model name Item	MR-J3BUS5M-A	MR-J3BUS10M-A	MR-J3BUS20M-A
Cable length [m(ft.)]	5(16.40)	10(32.81)	20(65.62)

(c) MR-J3BUS□M-B

Model name Item	MR-J3BUS30M-B	MR-J3BUS40M-B	MR-J3BUS50M-B
Cable length [m(ft.)]	30(98.43)	40(131.23)	50(164.04)

2 SYSTEM CONFIGURATION

(4) Setting of the axis No. and axis select switch of servo amplifier

Axis No. is used to set the axis numbers of servo amplifiers connected to SSCNETⅢ connector(CN□) in the program.

Axis No. of 1 to 32 can be set for Q173HCPU, and axis No. of 1 to 8 can be set for Q172HCPU.

Axis No. is set for each system of SSCNETⅢ in the system setting of programming software. Axis No. (Q173HCPU:1 to 32/Q172HCPU:1 to 8) is allocated and set for the setting axis number (d01 to d16) of servo amplifier. Since the axis number (d01 to d16) of servo amplifier on the system setting screen corresponds to axis select switch (0 to F) of servo amplifier, set the axis select switch referring to the table of next page.

• System setting (Allocation of axis No.)

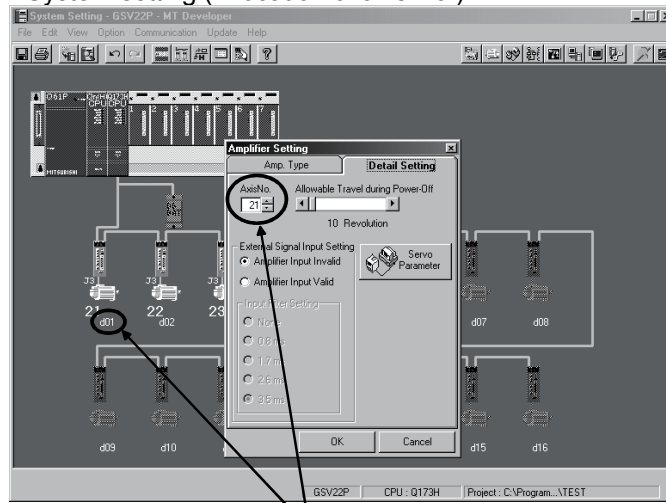

• Set the axis No. relative to axis number (dno.).

• Axis select switch (Servo amplifier)

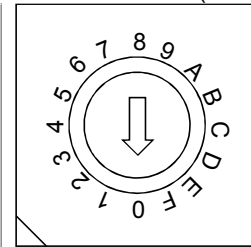

(Note) : Correspondence between dno. and axis select switch of servo amplifiers is shown in the next page.

2 SYSTEM CONFIGURATION

Correspondence between dno.s and axis select switches of servo amplifier

dno. (Note)	SSCNETⅢ system	Axis select switch of servo amplifier	dno. (Note)	SSCNETⅢ system	Axis select switch of servo amplifier
d01	1	"0"	d01	2	"0"
d02	1	"1"	d02	2	"1"
d03	1	"2"	d03	2	"2"
d04	1	"3"	d04	2	"3"
d05	1	"4"	d05	2	"4"
d06	1	"5"	d06	2	"5"
d07	1	"6"	d07	2	"6"
d08	1	"7"	d08	2	"7"
d09	1	"8"	d09	2	"8"
d10	1	"9"	d10	2	"9"
d11	1	"A"	d11	2	"A"
d12	1	"B"	d12	2	"B"
d13	1	"C"	d13	2	"C"
d14	1	"D"	d14	2	"D"
d15	1	"E"	d15	2	"E"
d16	1	"F"	d16	2	"F"

(Note) : The dno. is number of servo amplifier axis displayed in the system setting of programming software. Axis No. is set relative to dno. in the system settings.

Correspondence between SSCNETⅢ system and connector No. of CPU is shown below.

Correspondence between SSCNETⅢ system No. and connector No. of CPU

SSCNETⅢ system No.	Connector No. of CPU
1	SSCNETⅢ CN1
2	SSCNETⅢ CN2

(Note) : Number of SSCNETⅢ systems: Q173HCPU : 2 systems / Q172HCPU : 1 system

2 SYSTEM CONFIGURATION

2.4.10 External battery

This section describes the battery specifications used in the Motion CPU, handling precautions and equipments.

(1) External battery specifications(For Motion CPU module)

Item	Model name	Q6BAT
Classification		Manganese dioxide lithium primary battery
Initial voltage [V]		3.0
Nominal capacity [mAh]		1800
Storage life		Actually 5 years (Room temperature)
Lithium content [g]		0.49
Applications		For long continuous power failure (For IC-RAM memory back-up of Q173HCPU/Q172HCPU)
Exterior dimensions [mm(inch)]		φ 16(0.63)×32(1.26)

(Note) : The 44th Edition of the IATA (International Air Transportation Association) Dangerous Goods Regulations was effected in January 1st, 2003 and administered immediately.

In this edition, the provisions relating to lithium and lithium ion batteries have been revised to strengthen regulations on the air transportation of battery.

This battery is not dangerous goods (not class 9). Therefore, these batteries of 24 units or less are not subject to the regulations.

These batteries more than 24 units require packing based on Packing Instruction 903.

If you need the self-certification form for the battery safety test, contact Mitsubishi.

For more information, contact Mitsubishi.

(2) Q173HCPU/Q172HCPU back-up by the external battery

When using the external battery, set the external battery(Q6BAT) in the system settings.

Set the external battery (Q6BAT) to battery holder unit (Q170HBATC) in the case.

Item		Guaranteed time (MIN) [h]	Actual time(TYP) [h]
Continuous power failure time	External battery use	60000	240000

(Note) : The self-discharge influences the service life time of battery. The external battery should be exchanged approximately every four or five years.

! CAUTION

- Do not short a battery.
- Do not charge a battery.
- Do not disassemble a battery.
- Do not burn a battery.
- Do not overheat a battery.
- Do not solder the battery terminal.
- When using the external battery, be sure to select "the external battery use" in the system settings. If not setting the external battery, the back-up data of Motion CPU may not back up, since the battery voltage detection error is not detected.

(3) Connection procedure with Q173HCPU/Q172HCPU

(a) Set the Q6BAT to the Battery holder unit(Q170HBATC).

(b) Connect the Q6BAT connector to the BAT connector of Q170HBATC.

(c) Connect between BAT of Q173HCPU/Q172HCPU and CPU of Q170HBATC.

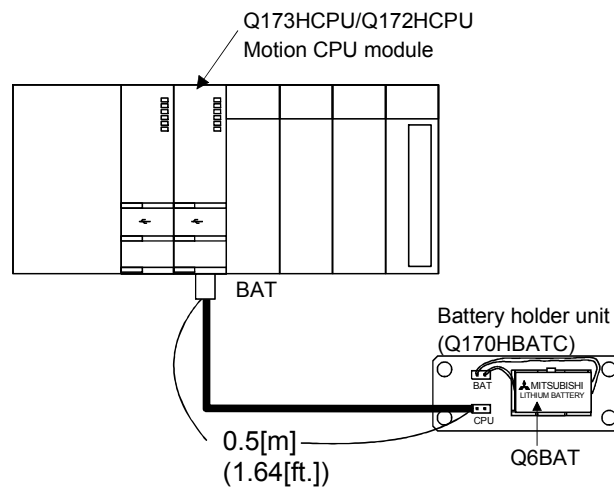

3. DESIGN

3.1 System Designing Procedure

Design the system which uses the Multiple CPU system in the following procedure.

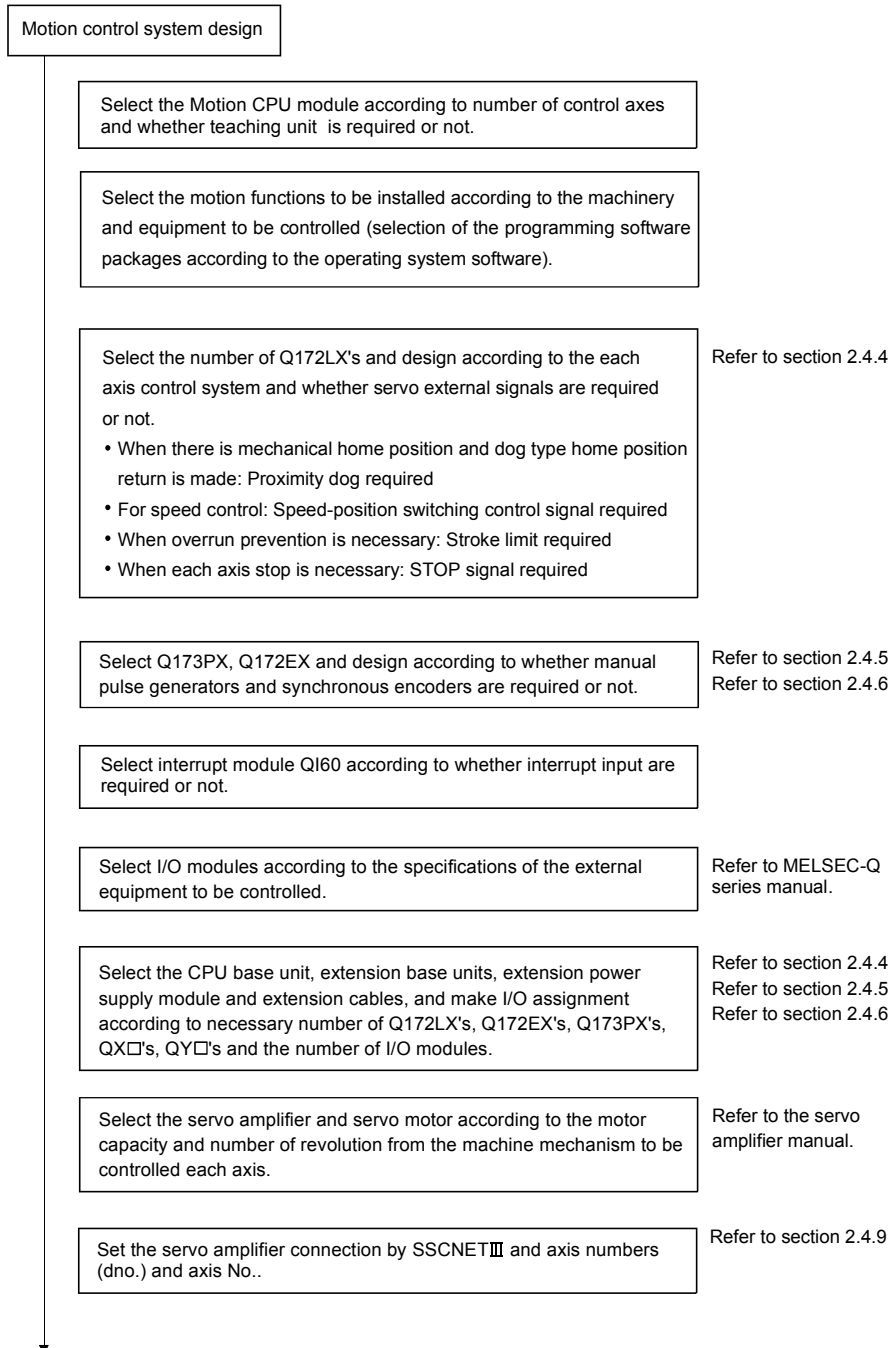

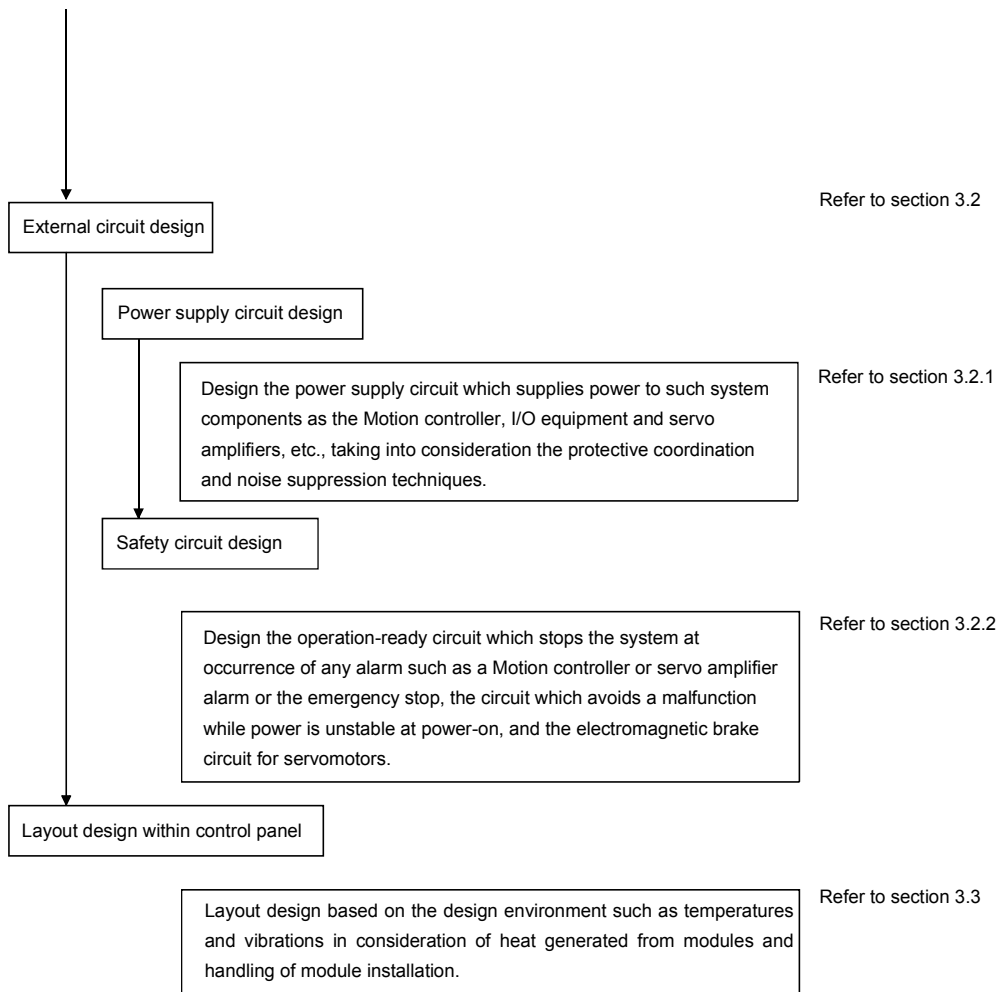

⚠ CAUTION

- Provide appropriate circuits external to the Motion CPU to prevent cases where danger may result from abnormal operation of the overall system in the event of an external power supply fault or Motion CPU failure.
- Install the Motion controller, servo amplifier, servomotor, and regenerative resistor on inflammable material. Direct installation on flammable material or near flammable material may lead to fire.
- If a fault occurs in the Motion controller or servo amplifier, shut the power OFF at the servo amplifier's power source. If a large current continues to flow, fire may occur.
- When using a regenerative resistor, shut the power OFF with an error signal. The regenerative resistor may abnormally overheat due to a fault in the regenerative transistor, etc., and may lead to fire.
- Always take heat measures such as flame proofing for the inside of the control panel where the servo amplifier or regenerative resistor is installed and for the wires used. Failing to do so may lead to fire.
- Do not apply a voltage other than that specified in the instruction manual on any terminal. Doing so may lead to destruction or damage.
- Do not mistake the polarity (+ / -), as this may lead to destruction or damage.

CAUTION

- Do not touch the servo amplifier's heat radiating fins, regenerative resistor and servomotor, etc. while the power is ON and for a short time after the power is turned OFF. In this timing, these parts become very hot and may lead to burns.
- Always turn the power OFF before touching the servomotor shaft or coupled machines, as these parts may lead to injuries.
- Do not go near the machine during test operations or during operations such as teaching. Doing so may lead to injuries.
- Always install a leakage breaker on the Motion controller and servo amplifier power source.
- If installation of an electromagnetic contactor for power shut off during an error, etc., is specified in the instruction manual for the servo amplifier, etc., always install the electromagnetic contactor.
- Install an emergency stop circuit externally so that the operation can be stopped immediately and the power shut off.
- Use the Motion controller, servo amplifier, servomotor and regenerative resistor with the combinations listed in the instruction manual. Other combinations may lead to fire or faults.
- If safety standards (ex., robot safety rules, etc.,) apply to the system using the Motion controller, servo amplifier and servomotor, make sure that the safety standards are satisfied.
- Construct a safety circuit externally of the Motion controller or servo amplifier if the abnormal operation of the Motion controller or servo amplifier differ from the safety directive operation in the system.
- In systems where coasting of the servomotor will be a problem during the forced stop, the emergency stop, servo OFF or when the power is shut OFF, use dynamic brakes.
- Make sure that the system considers the coasting amount even when using dynamic brakes.
- In systems where perpendicular shaft dropping may be a problem during the forced stop, the emergency stop, servo OFF or when the power is shut OFF, use both dynamic brakes and electromagnetic brakes.
- The dynamic brakes must be used only during the forced stop, the emergency stop and errors where servo OFF occurs. These brakes must not be used for normal braking.
- The brakes (electromagnetic brakes) assembled into the servomotor are for holding applications, and must not be used for normal braking.
- The system must have a mechanical allowance so that the machine itself can stop even if the stroke limits switch is passed through at the max. speed.
- Use wires and cables that have a wire diameter, heat resistance and bending resistance compatible with the system.
- Use wires and cables within the length of the range described in the instruction manual.
- The ratings and characteristics of the parts (other than Motion controller, servo amplifier, servomotor) used in a system must be compatible with the Motion controller, servo amplifier and servomotor.
- Install a cover on the shaft so that the rotary parts of the servomotor are not touched during operation.
- There may be some cases where holding by the electromagnetic brakes is not possible due to the service life time or mechanical structure (when the ball screw and servomotor are connected with a timing belt, etc.). Install a stopping device to ensure safety on the machine side.

3 DESIGN

3.2 External Circuit Design

As to the ways to design the external circuits of the Motion system, this section explains the method and instructions for designing the power supply circuits and safety circuits, etc.

(1) Sample system circuit design for motion control 1

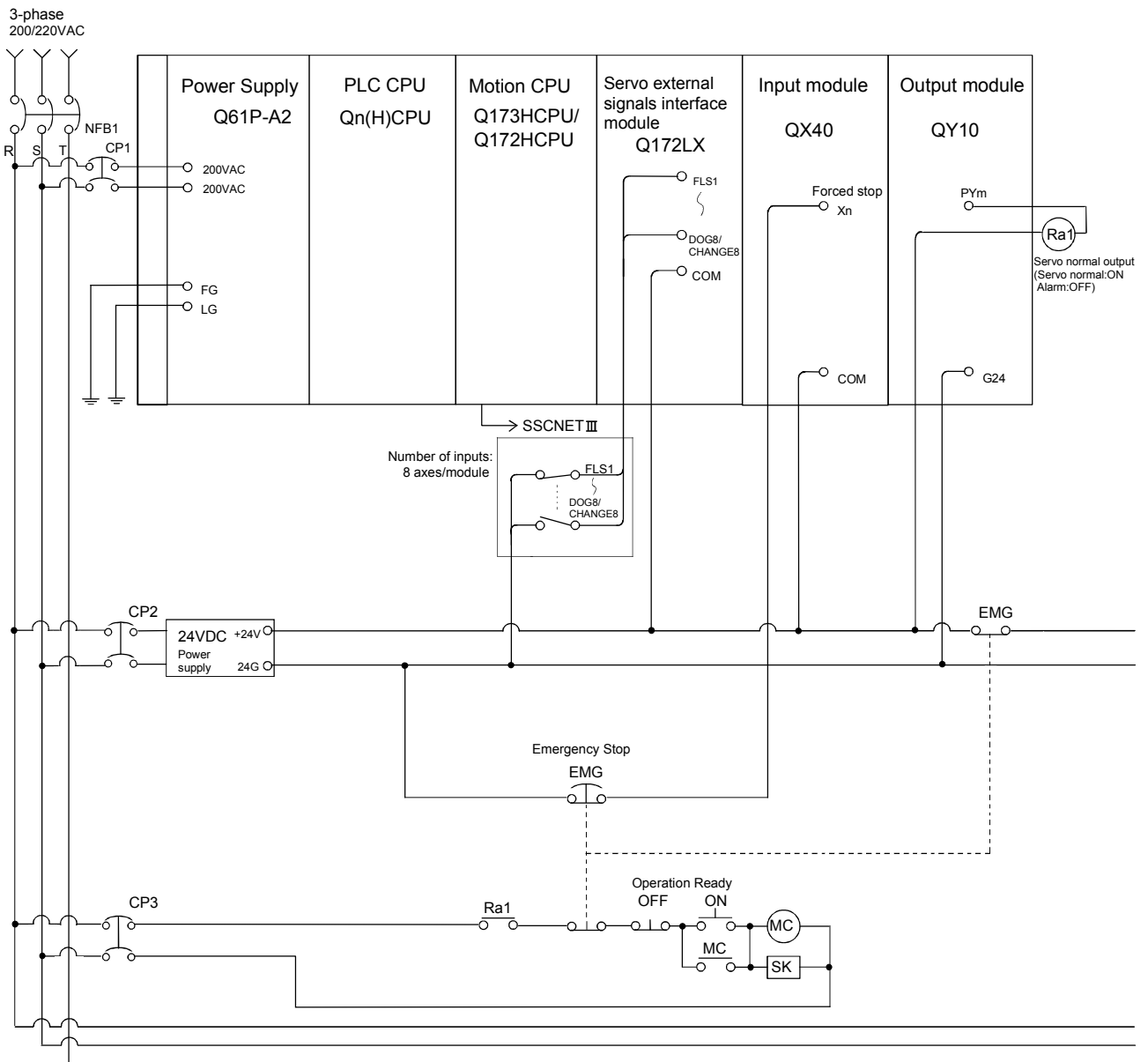

3 DESIGN

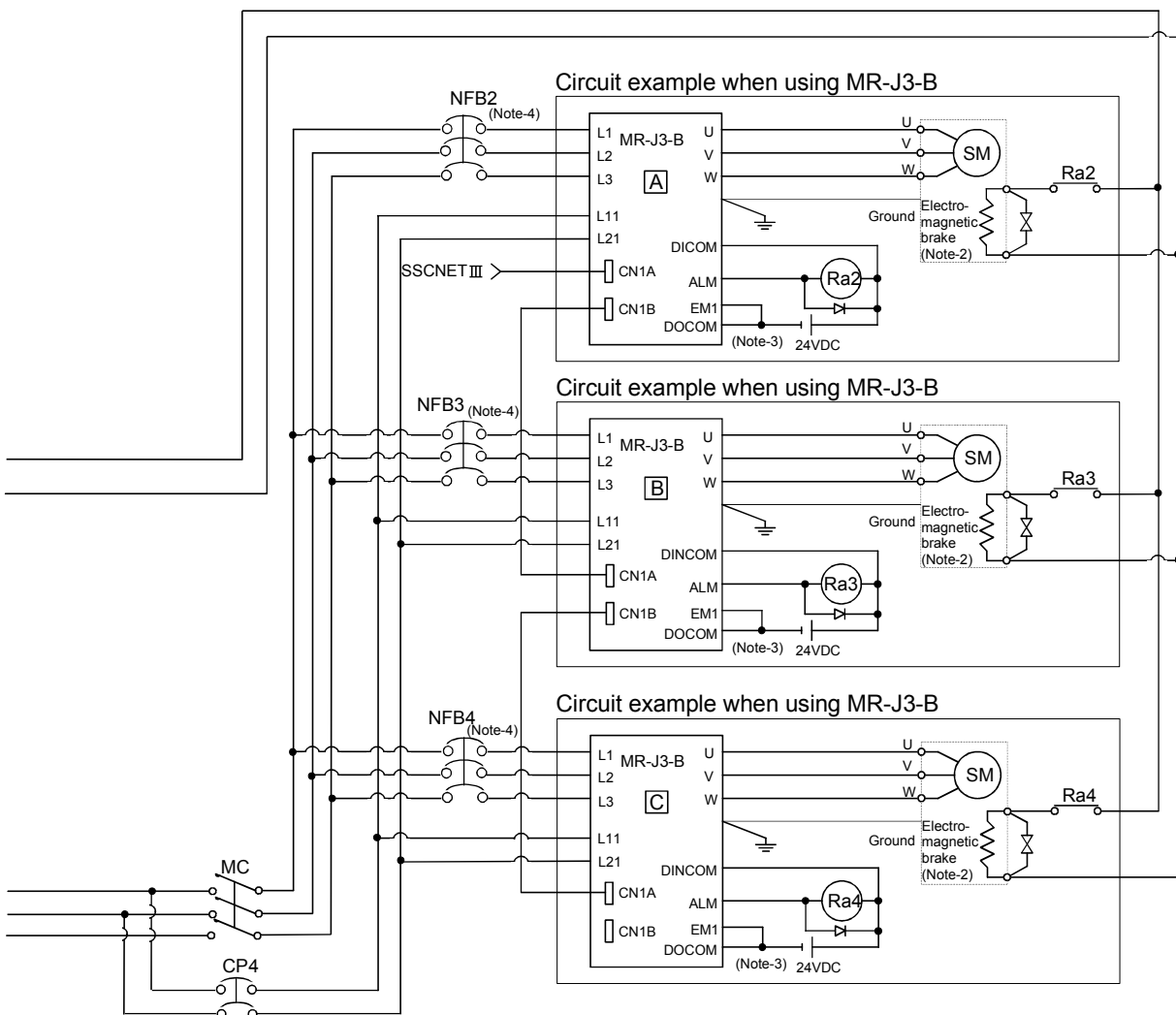
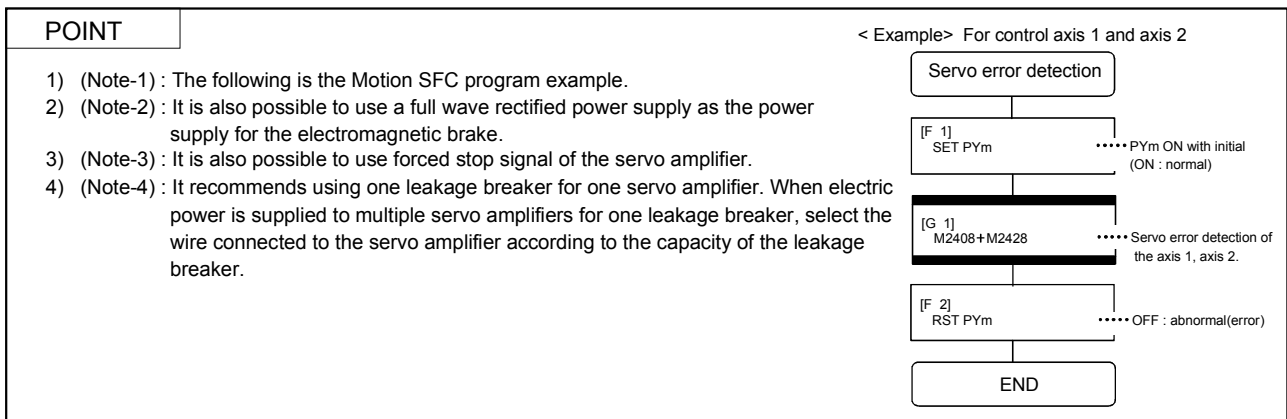

(Note-1) : When the control power supply of servo amplifier is shut off, it is not possible to communicate with the servo amplifier after that.
 Example) When the control power supply L11/L21 of servo amplifier in above **[B]** figure is shut off, it is also not possible to communicate with the servo amplifier **[C]**.

If only a specific servo amplifier power supply is shut off, be sure to shut off the main circuit power supply L1/L2/L3, and do not shut off the control power supply L11/L21.

(Note-2) : Be sure to shut off the both of main circuit power supply L1/L2/L3 and control power supply L11/L21 at the time of exchange of servo amplifier. At this time, it is not possible to communicate between the servo amplifier and Motion controller. Therefore, be sure to exchange the servo amplifier after stopping the operating of machine beforehand.

3 DESIGN

(2) Sample system circuit design for motion control 2 (For A31TU-DN□)

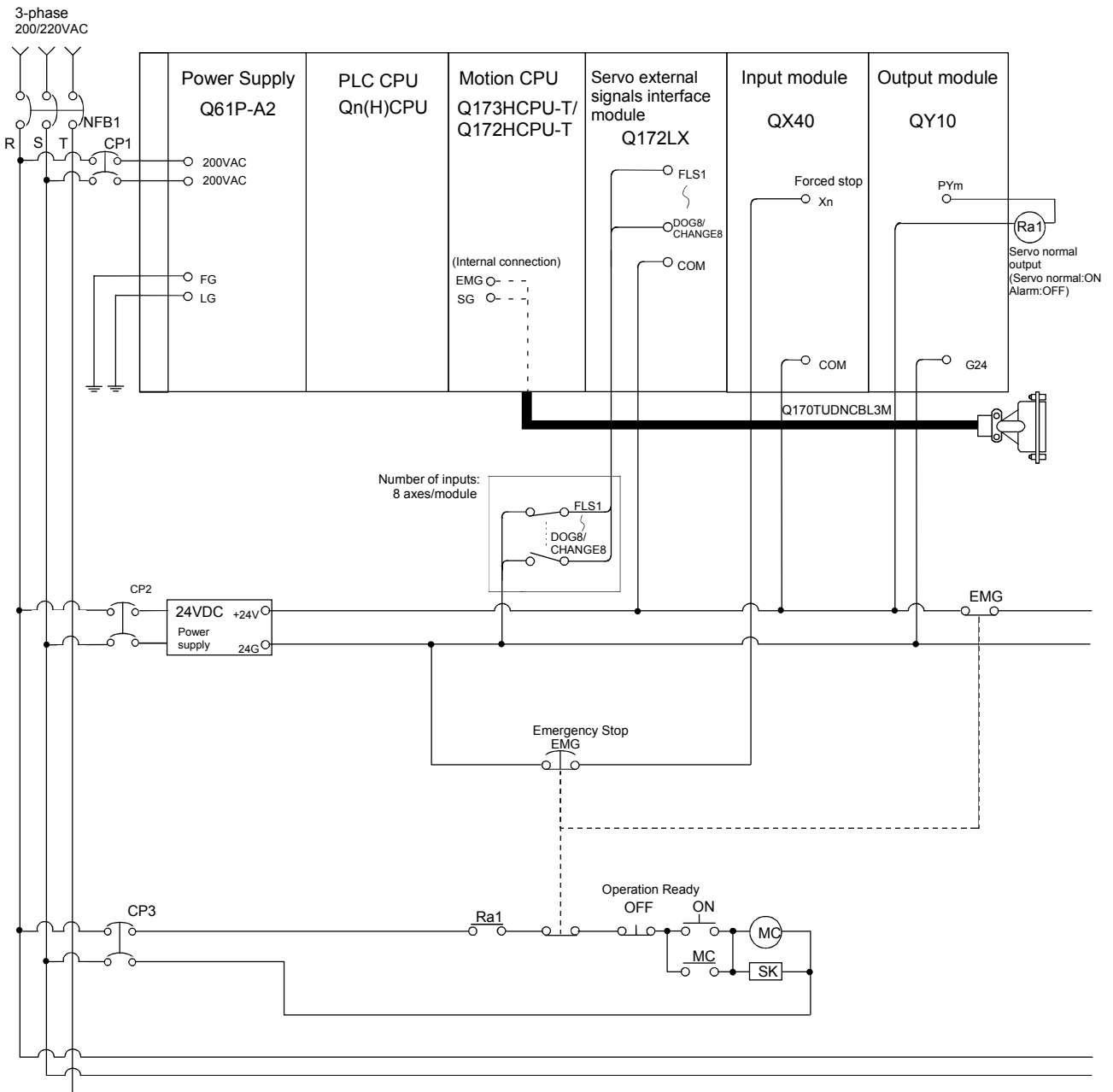

3 DESIGN

POINT	
1) (Note-1) : The following is the Motion SFC program example.	<p>< Example > For control axis 1 and axis 2</p> <pre> graph TD Start([Servo error detection]) --> F1[F 1 SET PYm] F1 --> G1[G 1 M2408+M2428] G1 --> F2[F 2 RST PYm] F2 --> End([END]) </pre>
2) (Note-2) : It is also possible to use a full wave rectified power supply as the power supply for the electromagnetic brake.	
3) (Note-3) : It is also possible to use forced stop signal of the servo amplifier.	
4) (Note-4) : It recommends using one leakage breaker for one servo amplifier. When electric power is supplied to multiple servo amplifiers for one leakage breaker, select the wire connected to the servo amplifier according to the capacity of the leakage breaker.	

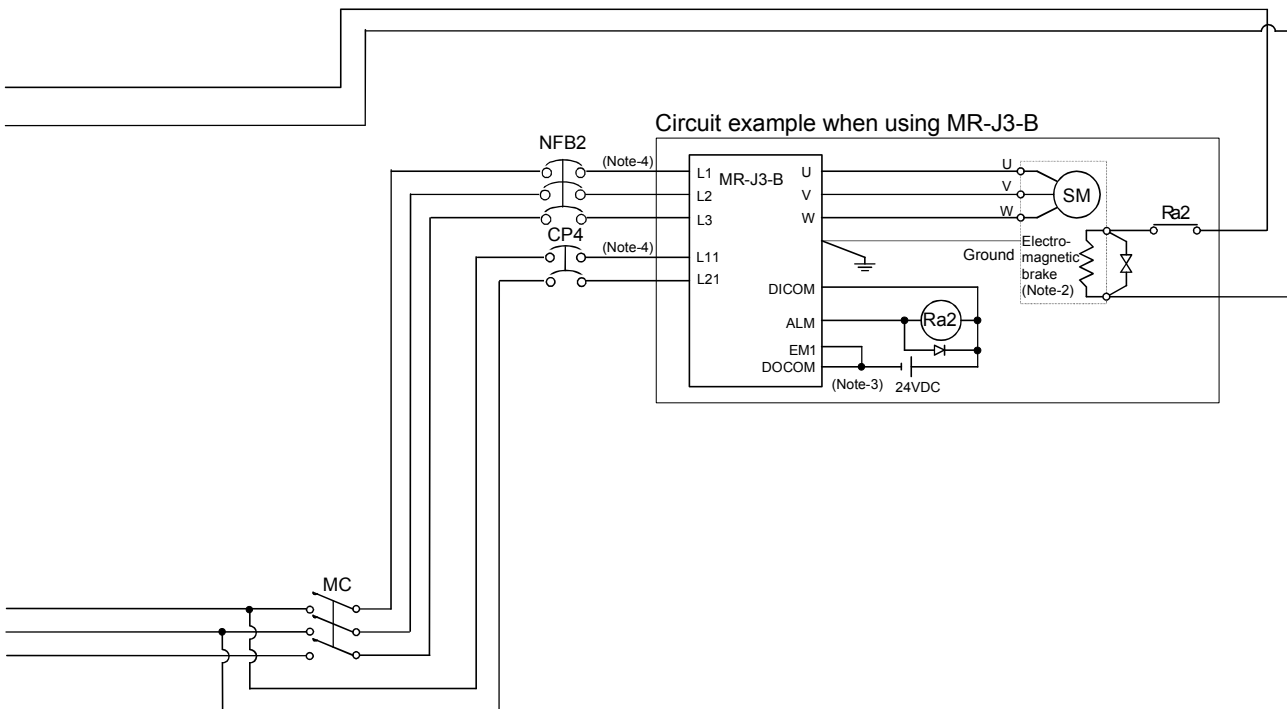
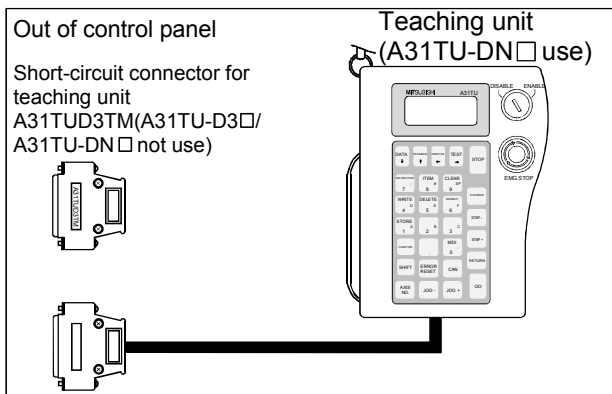

3 DESIGN

(3) Sample system circuit design for motion control 3 (For A31TU-D3□)

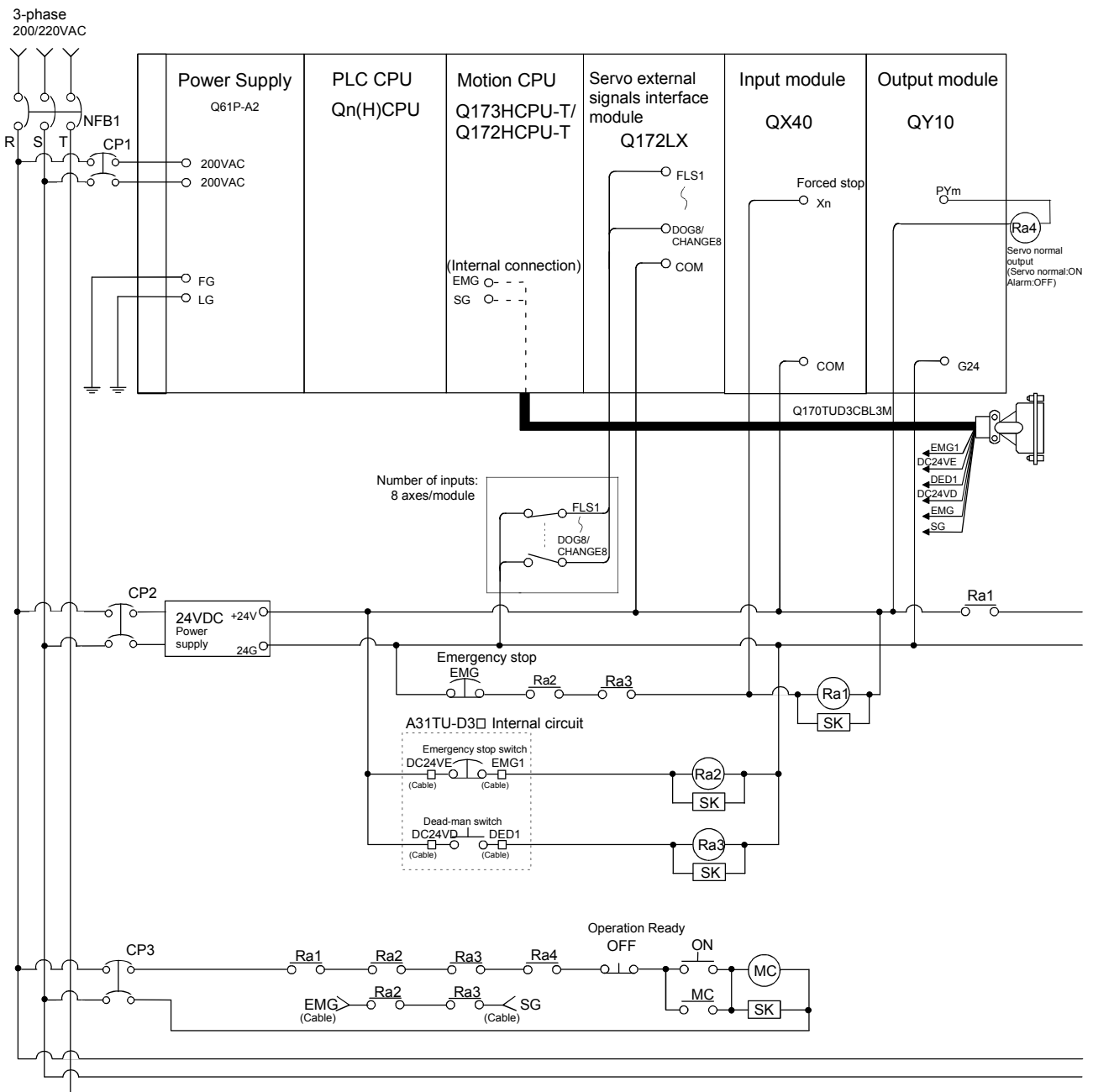

3 DESIGN

POINT	
1) (Note-1) : The following is the Motion SFC program example.	<p>< Example > For control axis 1 and axis 2</p>
2) (Note-2) : It is also possible to use a full wave rectified power supply as the power supply for the electromagnetic brake.	
3) (Note-3) : It is also possible to use forced stop signal of the servo amplifier.	
4) (Note-4) : It recommends using one leakage breaker for one servo amplifier. When electric power is supplied to multiple servo amplifiers for one leakage breaker, select the wire connected to the servo amplifier according to the capacity of the leakage breaker.	
5) Please contact your nearest Mitsubishi sales representative, when you construct a double circuit by external safety circuit.	
6) Sample system circuit design is not based on JIS B9705-1/ISO 13849-1/EN954-1 (Safety of machinery - Safety related parts of control systems), ansi/RIA R15.06 (American National Standard for industrial Robots and Robot systems - Safety requirements revision), and JIS B8433 (Manipulating industrial robots - Safety).	

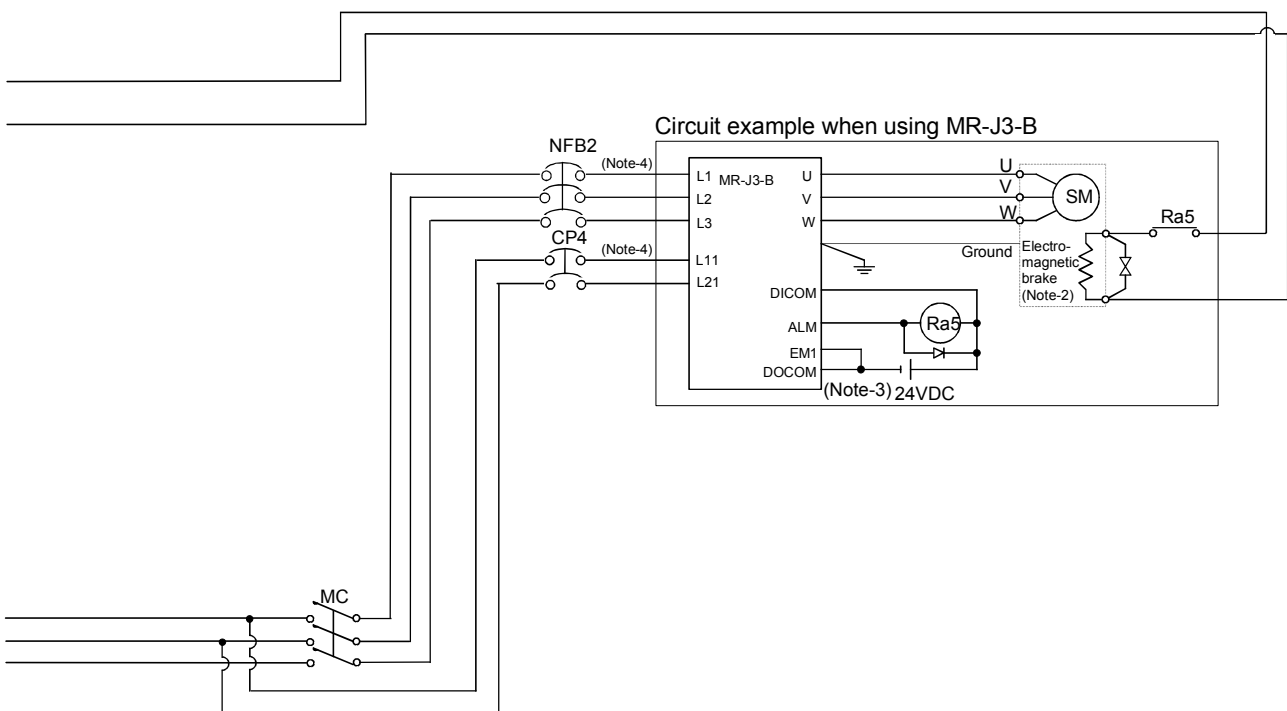
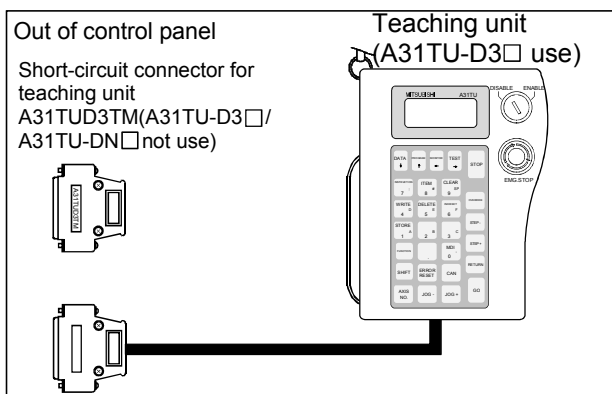

(4) System design circuit example of the PLC I/O

(a) System design circuit example (when not using ERR contact of power supply module)

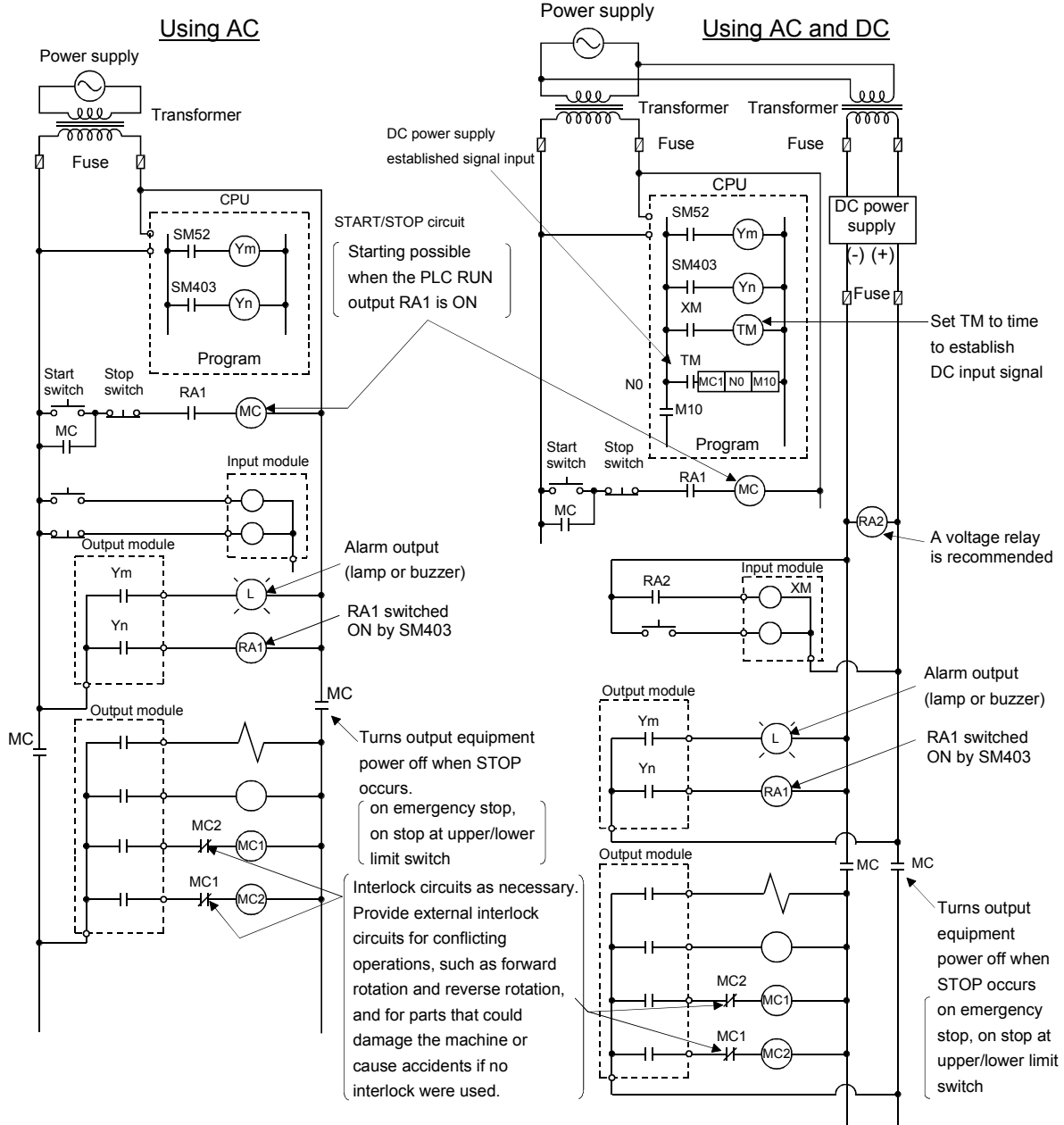

The power-ON procedure is as follows:

For AC

- 1) Switch power ON.
- 2) Set CPU to RUN.
- 3) Turn ON the start switch.
- 4) When the electromagnetic contactor (MC) comes on, the output equipment is powered and may be driven by the program.

For AC/DC

- 1) Switch power ON.
- 2) Set CPU to RUN.
- 3) When DC power is established, RA2 goes ON.
- 4) Timer (TM) times out after the DC power reaches 100[%]. (The TM set value should be the period of time from when RA2 goes ON to the establishment of 100[%] DC voltage. Set this value to approximately 0.5 seconds.)
- 5) Turn ON the start switch.
- 6) When the electromagnetic contactor (MC) comes on, the output equipment is powered and may be driven by the program. (If a voltage relay is used at RA2, no timer (TM) is required in the program.)

(b) System design circuit example (when using \overline{ERR} contact of power supply module)

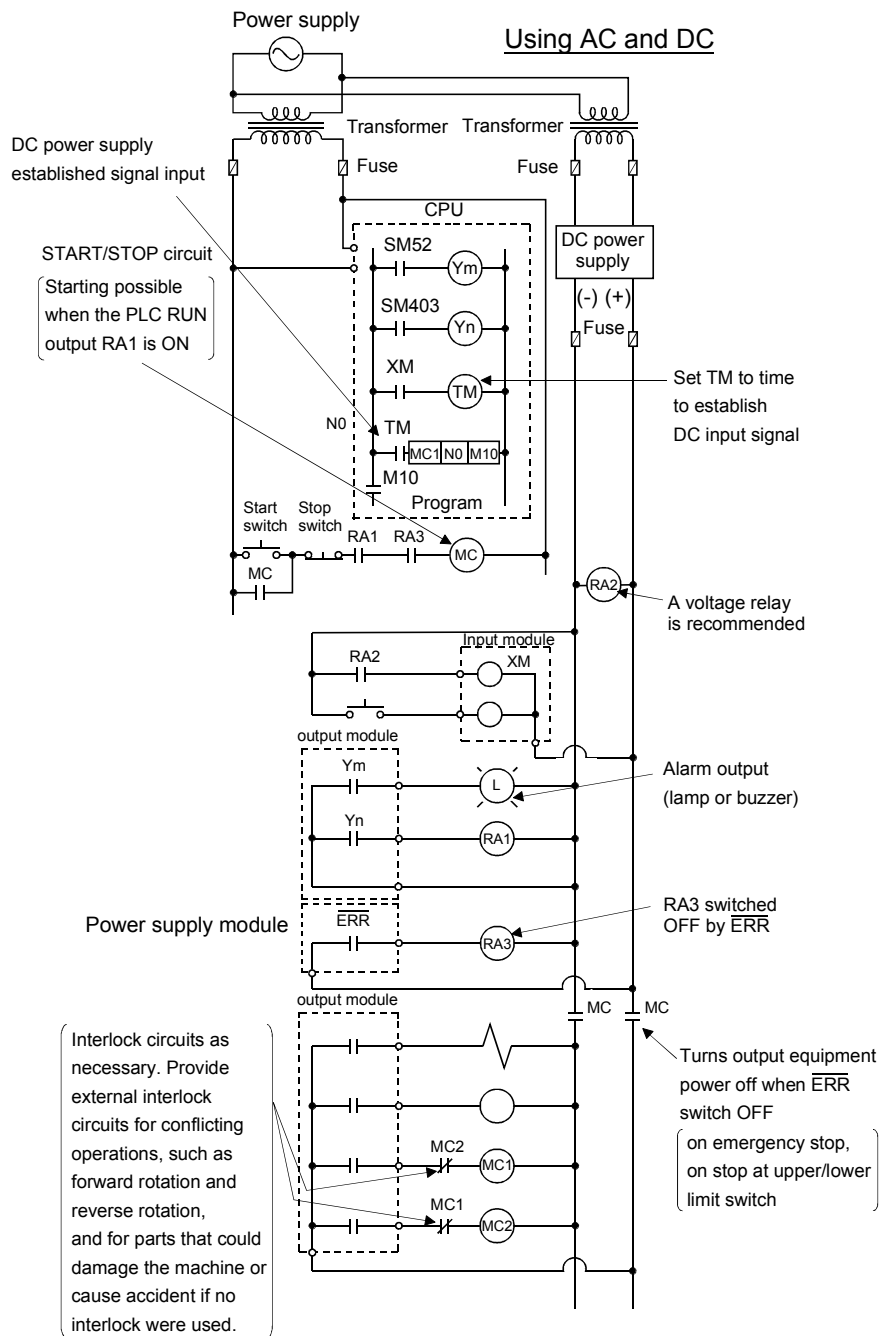

The power-ON procedure is as follows:

For AC/DC

- 1) Switch power ON.
- 2) Set CPU to RUN.
- 3) When DC power is established, RA2 goes ON.
- 4) Timer (TM) times out after the DC power reaches 100[%]. (The TM set value should be the period of time from when RA2 goes ON to the establishment of 100[%] DC voltage. Set this value to approximately 0.5 seconds.)
- 5) Turn ON the start switch.
- 6) When the electromagnetic contactor (MC) comes on, the output equipment is powered and may be driven by the program. (If a voltage relay is used at RA2, no timer (TM) is required in the program.)

3.2.1 Power supply circuit design

This section describes the protective coordination and noise suppression techniques of the power supply circuit.

(1) Separation and protective coordination (leakage current protection, over current protection) of power supply systems

When wiring, separate the lines of Multiple CPU system power supplies from those of the I/O equipment and servo amplifier as shown below.

When there is much noise, connect an insulation transformer.

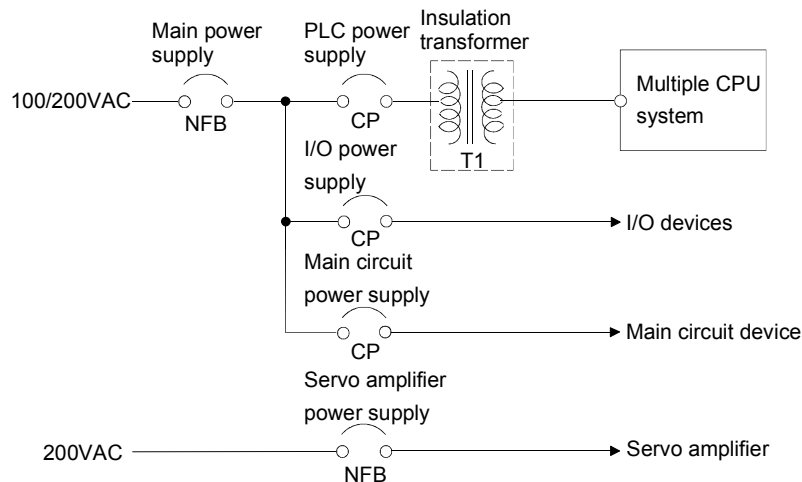

(2) Grounding

The Motion system may malfunction as it is affected by various noises such as electric path noises from the power supply systems, radiated and induced noises from other equipment, servo amplifiers and their cables, and electromagnetic noises from conductors. To avoid such troubles, connect the earthing ground of each equipment and the shield grounds of the shielded cables to the earth. Also use ferrite cores (ex., ZCAT3035-1330(TDK make)) to prevent the sneak noises from the panel personal computer.

For grounding, use the exclusive ground terminal wire of each equipment or a single-point earth method to avoid grounding by common wiring, where possible, since noises may sneak from other equipment due to common impedances.

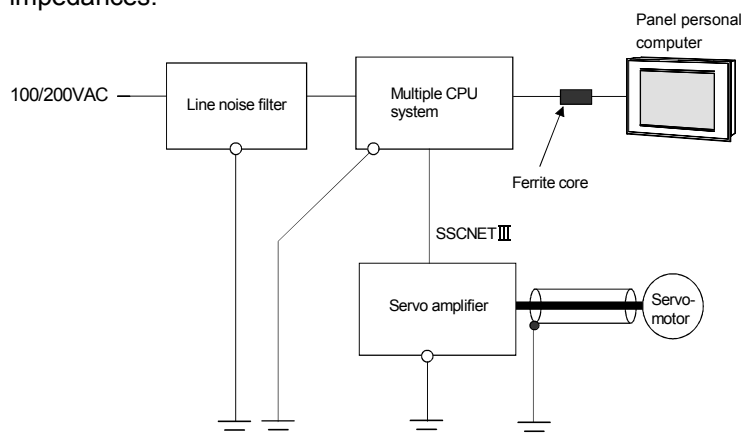

(Note): Be sure to ground the line noise filter, Multiple CPU system, servo amplifier and servomotor. (Ground resistance : 100 Ω or less)

3.2.2 Safety circuit design

(1) Concept of safety circuits

When the Motion controller is powered on-off, proper outputs may not be provided temporarily due to the delays and rise times of the Motion controller power supply and external I/O control power supplies (especially DC). Also, abnormal operations may be performed when the external power supply becomes faulty or the Motion controller fails.

Construct the circuit (emergency stop, protective and interlock circuits, etc.) of parts which may occur machine breakdown and accidents due to abnormal operations outside of the Motion controller in a fail-safe viewpoint, to avoid abnormal operations of whole system.

(2) Emergency stop circuit

The circuit should be constructed outside of the Motion controller or servo amplifier. Shut off the power supply to the external servo amplifier by this circuit, make the electromagnetic brakes of the servomotor operated.

(3) Forced stop circuit

(a) It is possible to effect the forced stop all axes of the servo amplifier at once via the forced stop input of the input modules. After the forced stop, remove the forced stop factor and cancel the forced stop. (The servo error detection signal does not turn on with the forced stop.)

It is possible to set the forced stop input No. by the parameter setting of the system setting.

The forced stop wiring example is shown below.

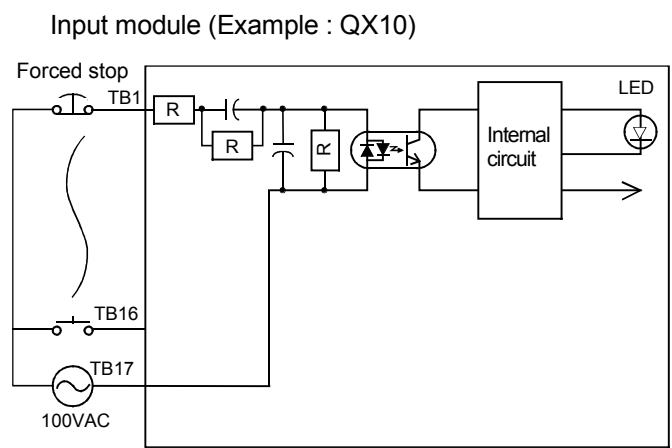

(Note): It is possible to set the forced stop (Xn) of the system settings at the user side.

3 DESIGN

- (b) It is also possible to use the forced stop signal of the servo amplifier.
Refer to manual of the servo amplifier about servomotor capacity.
Operation status of the emergency stop and the forced stop are as follows.

Item	Operation of the signal ON	Remark
Emergency stop	Servo OFF	Shut off the power supply to the external servo amplifier by external circuit, make the servomotor stopped.
Forced stop		The servomotor is stopped according to the stop instruction from Motion controller to the servo amplifier.

3.3 Layout Design within The Control Panel

3.3.1 Installation environment

Install the Motion controller system in the following environment conditions.

- (1) Ambient temperature is within the range of 0° to 55°C (32° to 131°F) .
- (2) Ambient humidity is within the range of 5 to 95[%]RH.
- (3) No condensing from sudden temperature changes
- (4) No corrosive or inflammable gas
- (5) There must not be a lot of conductible dust, iron filings, oil mist, or salt, organic solvents.
- (6) No direct sunlight
- (7) No strong electrical or magnetic fields
- (8) No direct vibrations or shocks on the Motion controller

3 DESIGN

3.3.2 Layout design of the base units

This section describes the precautions related to install a Motion controller in an enclosure.

- (1) To improve ventilation and permit easy replacement of the module, leave a space of the following table between the top, bottom, side of the module and any other object.

(For details on layout design refer to section 4.1.2 "Instructions for installation of the base unit".)

	Top	Bottom	Side
Duct height: over 50mm(1.97inch)	40mm(1.57inch) or more	100mm(3.94inch) or more	5mm(0.20inch) or more
Duct height: 50mm(1.97inch) or less	30mm(1.18inch) or more		

- (2) Provide a wiring duct, if required.

CAUTION

- Due to ventilation problems, do not install the base units vertically or horizontally.
- Install the base units on a flat surface. Unevenness or warping of the surface can apply undue force to printed circuit boards and lead to operation failures.
- Avoid installing the base units close to a vibration source, such as a large electromagnetic contactor or no-fuse breaker. Install them on a separate panel or at a safe distance.
- To limit the effects of reflected noise and heat, leave 100mm(3.94inch) or more clearance to instruments fitted in front of the Motion controller (on the rear of the door). Similarly, leave 50mm(1.97inch) or more clearance between instruments and the left and right sides of the base units.

3.3.3 Calculating heat generation by Motion controller

The ambient temperature inside the control panel storing the Motion controller must be suppressed to a Motion controller operating ambient temperature of 55°C(131°F). For the design of radiation from the storing panel, it is necessary to know the average power consumption (heating value) of the devices and instruments stored in the control panel. Here the method of obtaining the average power consumption of Q173HCPU/ Q172HCPU system is described. From the power consumption, calculate a rise in ambient temperature inside the control panel.

Calculating average power consumption

The power consuming parts of the Motion controller are roughly classified into six blocks as shown below.

(1) Power consumption of the power supply module

The power conversion efficiency of the power module is approx. 70 [%], i.e., 30 [%] of the output power is consumed by heating. As a result, 3/7 of the output power becomes the power consumption.

Therefore the calculation formula is as follows.

$$W_{pw} = \frac{3}{7} \times (I_{5V} \times 5) [W]$$

I_{5V} : Current consumption of logic 5 VDC circuit of each module

(2) Power consumption of a total of 5 VDC logic section of each module

The power consumption of the 5 VDC output circuit section of the power module is the power consumption of each module (including the current consumption of the base unit).

$$W_{5V} = I_{5V} \times 5 [W]$$

(3) A total of 24 VDC average power consumption of the output module (power consumption for simultaneous ON points)

The average power of the external 24 VDC power is the total power consumption of each module.

$$W_{24V} = I_{24V} \times 24 [W]$$

I_{24V} : Current consumption of the output module

(4) Average power consumption due to voltage drop in the output section of the output module (Power consumption for simultaneous ON points)

$$W_{OUT} = I_{OUT} \times V_{drop} \times \text{Number of output points} \times \text{Simultaneous ON rate} [W]$$

I_{OUT} : Output current (Current in actual use) [A]

V_{drop} : Voltage drop in each output module [V]

(5) Average power consumption of the input section of the input module(Power consumption for simultaneous ON points)

$$W_{IN} = I_{IN} \times E \times \text{Number of input points} \times \text{Simultaneous ON rate [W]}$$

I_{IN} : Input current (Effective value for AC) [A]

E : Input voltage (Voltage in actual use) [V]

(6) Power consumption of the power supply section of the intelligent function module

$$W_S = I_{5V} \times 5 + I_{24V} \times 24 + I_{100V} \times 100 [W]$$

The total of the power consumption values calculated for each block becomes the power consumption of the overall Motion system.

$$W = W_{PW} + W_{5V} + W_{24V} + W_{OUT} + W_{IN} + W_S [W]$$

From this overall power consumption [W], calculate the heating value and a rise in ambient temperature inside the control panel.

The outline of the calculation formula for a rise in ambient temperature inside the control panel is shown below.

$$T = \frac{W}{UA} [^{\circ}C]$$

W : Power consumption of overall Motion system (value obtained above)

A : Surface area inside the control panel[m²]

U : When the ambient temperature inside the control panel

is uniformed by a fan 6

When air inside the control panel is not circulated..... 4

POINT
<p>When a rise in ambient temperature inside the control panel exceeds the specified limit, it is recommended that you install a heat exchanger in the control panel to lower the ambient temperature inside the control panel.</p> <p>If a normal ventilating fan is used, dust will be sucked into the Motion controller together with the external air, and it may affect the performance of the Motion controller.</p>

(7) Example of average power consumption calculation (Q173HCPU use)

(a) System configuration

Q61P-A1	Q02HCPU	Q173HCPU	Q172LX	Q172EX-S2	Q173PX	QX40	QX40	QY10	QY10	Q38B
---------	---------	----------	--------	-----------	--------	------	------	------	------	------

(b) 5 VDC current consumption of each module

- Q02HCPU : 0.64 [A]
- Q173HCPU : 1.25 [A]
- Q172LX : 0.05 [A]
- Q172EX-S2 : 0.07 [A]
- Q173PX : 0.11 [A]
- QX40 : 0.05 [A]
- QY10 : 0.43 [A]
- Q38B : 0.114 [A]

(c) Power consumption of power module

$$W_{PW} = 3/7 \times (0.64 + 1.25 + 0.05 + 0.07 + 0.11 + 0.05 + 0.05 + 0.43 + 0.43 + 0.114) \times 5 = 6.84 \text{ [W]}$$

(d) Power consumption of a total of 5 VDC logic section of each module

$$W_{5V} = (0.64 + 1.25 + 0.05 + 0.07 + 0.11 + 0.05 + 0.05 + 0.43 + 0.43 + 0.114) \times 5 = 15.97 \text{ [W]}$$

(e) A total of 24 VDC average power consumption of the output module

$$W_{24V} = 192 \text{ [W]} \quad (8A/common)$$

(f) Average power consumption due to voltage drop in the output section of the output module

$$W_{OUT} = 0 \text{ [W]}$$

(g) Average power consumption of the input section of the input module

$$W_{IN} = 0.004 \times 24 \times 32 \times 1 = 3.07 \text{ [W]}$$

(h) Power consumption of the power supply section of the intelligent function module.

$$W_s = 0 \text{ [W]}$$

(i) Power consumption of overall system

$$W = 6.84 + 15.97 + 192 + 0 + 3.07 + 0 = 217.88 \text{ [W]}$$

3 DESIGN

3.4 Design Checklist

At the worksite, copy the following table for use as a check sheet.

Item	Sub Item	Design confirmation		Check	
Module selection	CPU module selection	Number of axes	axes	<input type="checkbox"/>	
		Number of I/O points	points	<input type="checkbox"/>	
		Motion CPU module selection		<input type="checkbox"/>	
		PLC CPU module selection		<input type="checkbox"/>	
	Motion module selection	Manual pulse generator		pcs.	<input type="checkbox"/>
		Synchronous encoder		pcs.	<input type="checkbox"/>
		Teaching unit			<input type="checkbox"/>
		Upper limit point		points	<input type="checkbox"/>
		Lower limit point		points	<input type="checkbox"/>
		STOP input point		points	<input type="checkbox"/>
		Proximity dog input point		points	<input type="checkbox"/>
		Speed switching input point		points	<input type="checkbox"/>
		Tracking enable signal point		points	<input type="checkbox"/>
		Q172LX		modules	<input type="checkbox"/>
		Q172EX		modules	<input type="checkbox"/>
		Q173PX		modules	<input type="checkbox"/>
		CPU base unit selection	Motion CPU module		modules
	I/O module installed to CPU base			modules	<input type="checkbox"/>
	CPU base unit selection				<input type="checkbox"/>
	Extension base unit and extension cable selection	Number of I/O modules installed to extension base		modules	<input type="checkbox"/>
Distance between CPU base and extension base			mm	<input type="checkbox"/>	
Extension base unit selection				<input type="checkbox"/>	
Extension cable selection				<input type="checkbox"/>	
External circuit design	Fail-safe circuit design	Avoidance of operation failure at power-on		<input type="checkbox"/>	
		Avoidance of hazard at Motion controller failure		<input type="checkbox"/>	
Layout design	Module layout design	Conformance with general specifications such as ambient temperature, humidity, dust, etc.		<input type="checkbox"/>	
		Total power consumption of base unit (Calculate the heating value)	W	<input type="checkbox"/>	
		Layout in consideration of clearances between enclosure's inside walls, other structures and modules and heats generated by modules within the control panel.		<input type="checkbox"/>	

4. INSTALLATION AND WIRING

4.1 Module Installation

4.1.1 Instructions for handling

 **CAUTION**

- Use the Motion controller in an environment that meets the general specifications contained in this manual. Using this Motion controller in an environment outside the range of the general specifications could result in electric shock, fire, operation failure, and damage to or deterioration of the product.
- Hold down the module loading lever at the module bottom, and securely install the module fixing hook into the fixing hole in the base unit. Incorrect loading of the module can cause an operation failure, failure or drop. When using the Motion controller in the environment of much vibration, tighten the module with a screw.
- Tighten the screw in the specified torque range. Under tightening may cause a drop, short circuit or operation failure. Over tightening may cause a drop, short circuit or operation failure due to damage to the screw or module.
- Be sure to install the extension cable to connectors of the base unit correctly. After installation, check them for looseness. Poor connections could cause an input or output failure.
- Completely turn off all lines of power supply externally before loading or unloading the module. Not doing so could result in electric shock or damage to the product.
- Do not directly touch the module's conductive parts. Touching the conductive parts could cause an operation failure or give damage to the module.

This section describes instructions for handling the CPU modules, I/O modules, intelligent function modules, power supply modules and base units, etc.

- (1) Do not drop or apply strong impact on the CPU modules, I/O modules, intelligent function modules, power supply modules, base units and memory card, etc.
- (2) Do not remove modules printed circuit boards from the case in order to avoid failure.
- (3) The module fixing screws and terminal block screws within the tightening torque range specified below.

Location of screw	Tightening torque range
Module fixing screw (M3 × 12 screw)	0.36 to 0.48 N•m
I/O module terminal block screw (M3 screw)	0.42 to 0.58 N•m
I/O module terminal block fixing screw (M3.5 screw)	0.66 to 0.89 N•m
Power supply module terminal screw (M3.5 screw)	0.66 to 0.89 N•m

- (4) Make sure to install the power supply module on the CPU base unit and extension base unit. When the power supply module is not installed and if the I/O modules and intelligent function module installed on the base units are light load type, the modules may be operated. In this case, because a voltage becomes unstable, we cannot guarantee the operation.

4 INSTALLATION AND WIRING

- (5) When an extension cable is used, do not bind the cable together with the main circuit (high voltage, heavy current) line or lay them close to each other.
- (6) Install the CPU base unit (by screwing) in the following procedure.
- (a) Fit the two fixing screws for top of the CPU base unit to the panel.



- (b) Place the right-hand side notch of the CPU base unit onto the right-hand side screw.

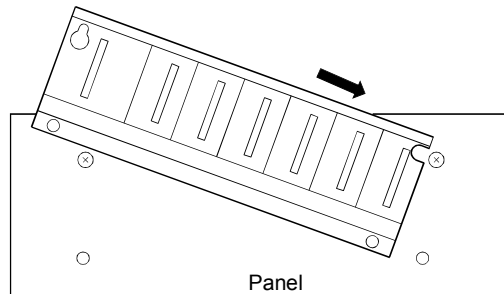

- (c) Place the left-hand side pear-shaped hole of the CPU base unit onto the left-hand side screw.

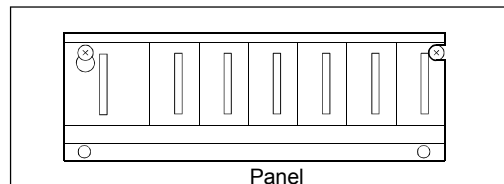

- (d) Fit the fixing screws into the fixing screw holes in the CPU base unit bottom and re-tighten the four fixing screws.

(Note) : Install the CPU base unit to a panel, with no module installed in the rightmost slot.
Remove the CPU base unit after unloading the module from the rightmost slot.

4 INSTALLATION AND WIRING

4.1.2 Instructions for installation of the base unit

Install the Motion controller module to a panel, etc. , considering enough about operability, maintainability and environmental resistance.

(1) Fitting dimensions

Fitting dimensions of each base unit are as follows:

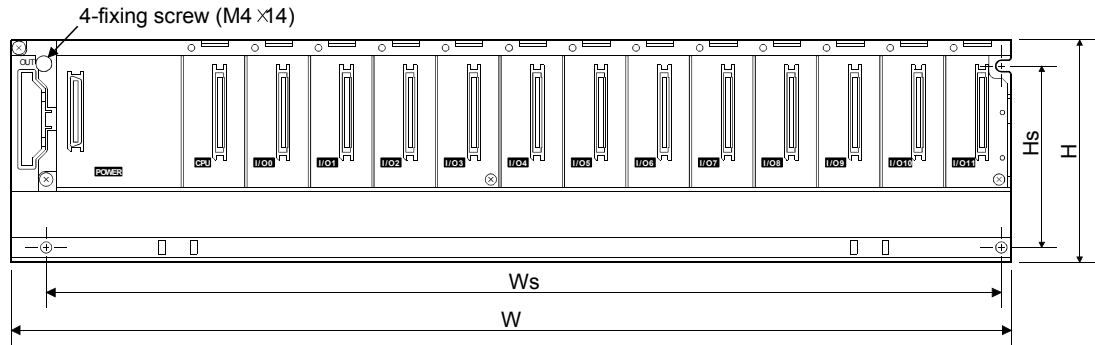

	Q35B	Q38B	Q312B	Q65B	Q68B	Q612B
W	245 (9.65)	328 (12.91)	439 (17.28)	245 (9.65)	328 (12.91)	439 (17.28)
Ws	224.5 (8.84)	308 (12.13)	419 (16.50)	222.5 (8.76)	306 (12.05)	417 (16.42)
H	98 (3.86)					
Hs	80 (3.15)					

[Unit: mm (inch)]

(2) Motion controller installation position

For enhanced ventilation and ease of module replacement, leave the following space between the module top/bottom and structure/parts.

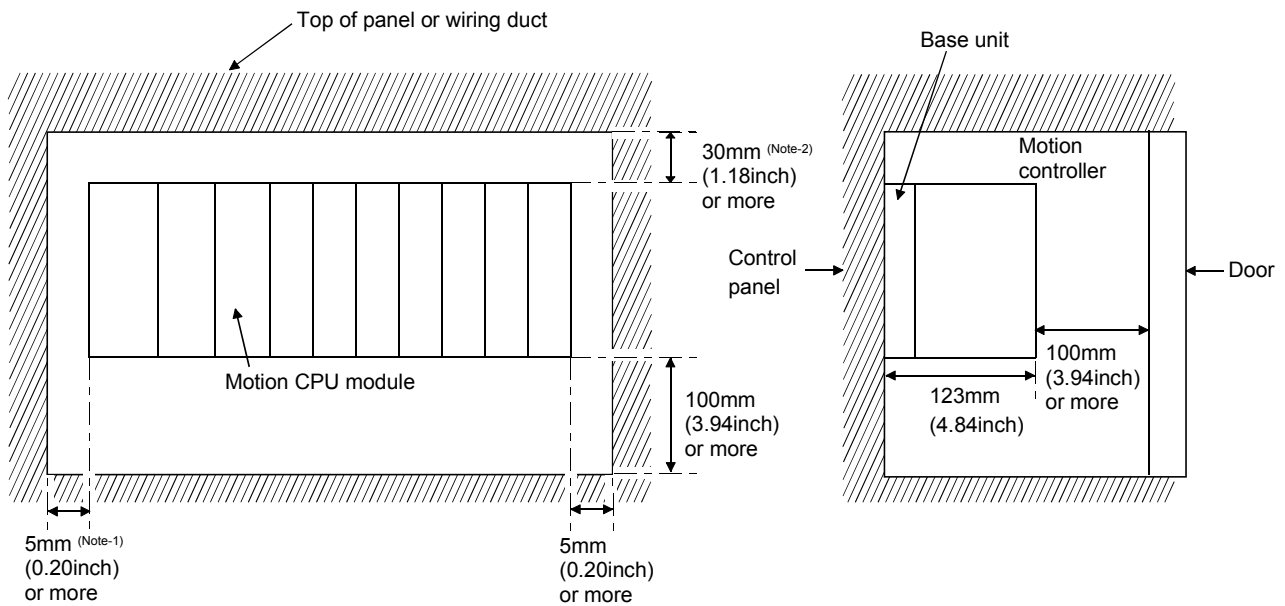

(Note-1) : 20mm (0.79 inch) or more when the extension cable is connected without removing the adjacent module.

(Note-2) : Height of a wiring duct is 50mm (1.97 inch) or more : 40mm (1.57 inch) or more

(3) Motion controller installation orientation

(a) Since the Motion controller generates heat, it should be fitted on a well ventilated location in the orientation shown below for heat release.

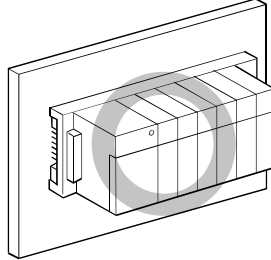

(b) Do not use it in either of the orientations shown below.

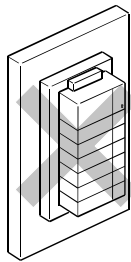

Vertical

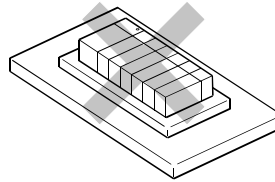

Flat

(4) Installation surface

Fit the base unit on a flat surface. If the installation surface is not even, this may strain the printed circuit boards and cause malfunctions.

(5) Installation of Motion controller in an area where the other devices are installed

Avoid fitting base unit in proximity to vibration sources such as large electromagnetic contractors and no-fuse circuit breakers; fit them on a separate panel or at a distance.

(6) Distances from the other devices

In order to avoid the effects of radiated noise and heat, provide the clearances indicated below between the Motion controller and the other devices (contactors and relays).

- In front of Motion controller: 100 mm (3.94 inch) or more
- On the right and left of Motion controller: 50 mm (1.97 inch) or more

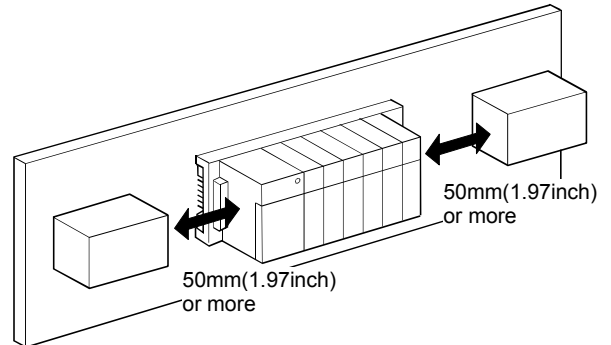
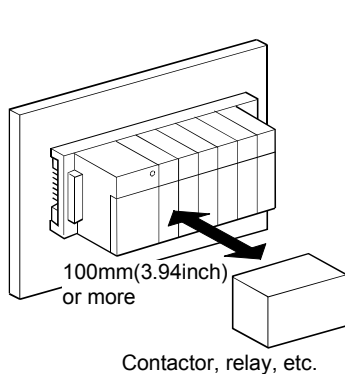

4 INSTALLATION AND WIRING

4.1.3 Installation and removal of module

This section explains how to install and remove a power supply module, PLC CPU module, Motion CPU module, Motion module, I/O module, intelligent function module or another module to and from the base unit.

(1) Installation and removal of the module from Q3□B, Q6□□B

The installation and removal procedure of the module from Q3□B/Q6□□B base unit are described below.

(a) Installation of the module to Q3□B and Q6□□B

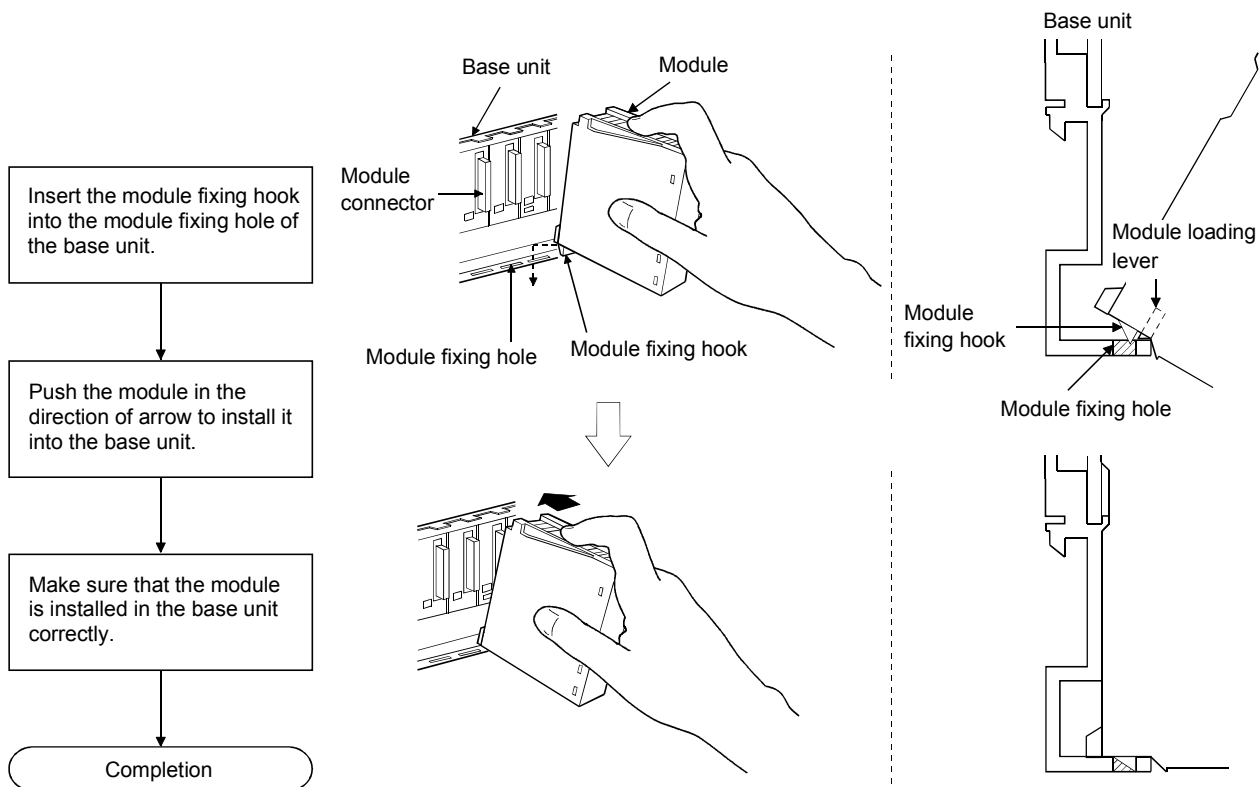

POINTS

- (1) Always insert the module fixing hook of the module into the module fixing hole. Forcing the hook into the hole will damage the module connector and module.
- (2) When using the modules in a place where there is large vibration or impact, screw the module to the base unit.
Module fixing screw : M3×12 (purchase from the other supplier)

(b) Removal from Q3□B and Q6□B

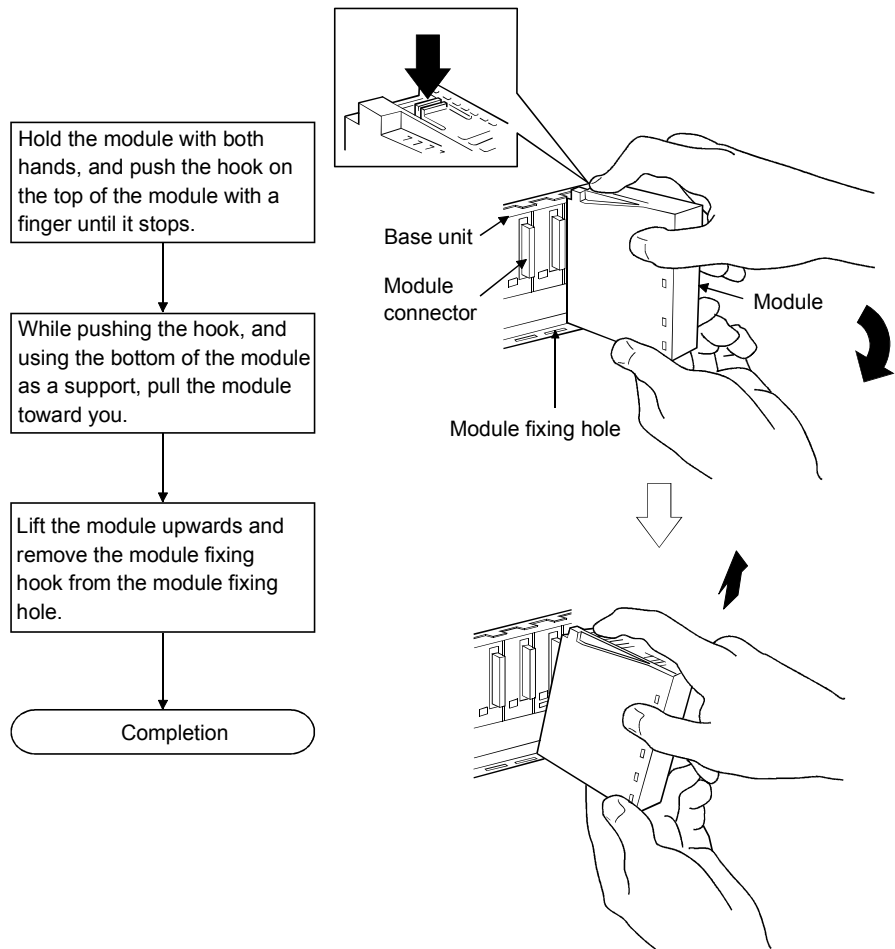

POINT

When the module fixing screw is used, always remove the module by removing the module fixing screw and then taking the module fixing hook off the module fixing hole of the base unit.

Forcibly removal the module will damage the module.

4 INSTALLATION AND WIRING

4.2 Installation and Removal of Cable

4.2.1 SSCNET III cable

(1) Precautions for handling the SSCNET III cable

- Do not stamp the SSCNET III cable.
- When laying the SSCNET III cable, be sure to secure the minimum cable bend radius or more. If the bend radius is less than the minimum cable bend radius, it may cause malfunctions due to characteristic deterioration, wire breakage, etc.

Model name of SSCNET III cable	Minimum bend radius[mm(inch)]
MR-J3BUS□M	25(0.98)
MR-J3BUS□M-A	Enforced covering cord: 50 (1.97) Code : 25 (0.98)
MR-J3BUS□M-B	Enforced covering cord: 50 (1.97) Code : 30 (1.18)

- For installation or removal of the SSCNET III cable, hold surely a tab of cable connector.
- Refer to Section 4.4.3. for wiring precautions.

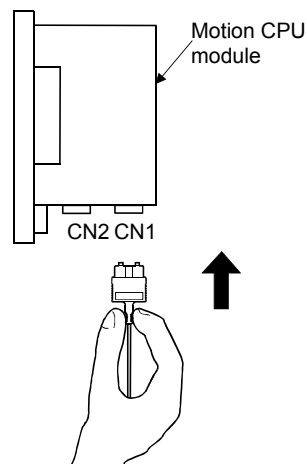

(2) Installation of the SSCNET III cable

- For installation of the SSCNET III cable to the Motion CPU, connect it to the SSCNET III connector CN1 or CN2 of Motion CPU while holding a tab of SSCNET III cable connector. Be sure to insert it until it clicks.

(3) Removal of the SSCNET III cable

- For removal of the SSCNET III cable, pull out it while holding a tab of SSCNET III cable connector or the connector.
- After removal of the SSCNET III cable, be sure to put a cap (attached to Motion CPU or servo amplifier) to the Motion CPU and servo amplifier.

POINTS

- (1) Be sure to connect SSCNETIII cable with the above connector. If the connection is mistaken, between the Motion CPU module and servo amplifier cannot be communicated.
- (2) Forcibly removal the SSCNETIII cable from the Motion CPU module will damage the Motion CPU modules and SSCNETIII cables.
- (3) After removal of the SSCNETIII cable, be sure to put a cap on the SSCNETIII connector. Otherwise, adhesion of dirt deteriorates in characteristic and it may cause malfunctions.
- (4) Do not remove the SSCNETIII cable while turning on the power supply of Multiple CPU system and servo amplifier.
Do not see directly the light generated from SSCNETIII connector of Motion CPU module or servo amplifier and the end of SSCNETIII cable. When the light gets into eye, may feel something is wrong for eye. (The light source of SSCNETIII cable complies with class1 defined in JISC6802 or IEC60825-1.)
- (5) If the SSCNETIII cable is added a power such as a major shock, lateral pressure, haul, sudden bending or twist, its inside distorts or brakes, and optical transmission will not be available.
Be sure to take care enough so that the short SSCNETIII cable is added a twist easily.
- (6) Be sure to use the SSCNETIII cable within the range of operating temperature described in this manual. Especially, as optical fiber for MR-J3BUS□M and MR-J3BUS□M-A are made of synthetic resin, it melts down if being left near the fire or high temperature. Therefore, do not make it touched the part which becomes high temperature, such as radiator or regenerative option of servo amplifier, or servomotor.
- (7) When laying the SSCNETIII cable, be sure to secure the minimum cable bend radius or more.
- (8) Put the SSCNETIII cable in the duct or fix the cable at the closest part to the Motion CPU module with bundle material in order to prevent SSCNETIII cable from putting its own weight on SSCNETIII connector.
When laying cable, the optical cord should be given loose slack to avoid from becoming smaller than the minimum bend radius, and it should not be twisted. When bundling the cable, fix and hold it in position by using cushioning such as sponge or rubber which does not contain migratable plasticizing.
If using adhesive tape for bundling the cable, fire resistant acetate cloth adhesive tape 570F (Teraoka Seisakusho Co., Ltd) is recommended.

POINTS

- (9) Migrating plasticizer is used for vinyl tape. Keep the MR-J3BUS□M, and MR-J3BUS□M-A cables away from vinyl tape because the optical characteristic may be affected.

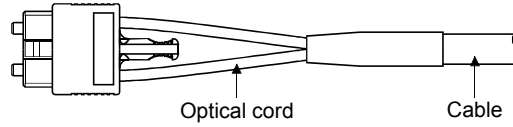

SSCNET III cable	Cord	Cable
MR-J3BUS□M	△	△
MR-J3BUS□M-A	△	△
MR-J3BUS□M-B	○	○

○: Normally, cable is not affected by plasticizer.

△: Phthalate ester plasticizer such as DBP and DOP may affect optical characteristic of cable.

Generally, soft polyvinyl chloride (PVC), polyethylene resin (PE) and fluorine resin contain non-migrating plasticizer and they do not affect the optical characteristic of SSCNET III cable. However, some wire sheaths and cable ties, which contain migrating plasticizer (phthalate ester), may affect MR-J3BUS□M and MR-J3BUS□M-A cables (made of plastic). In addition, MR-J3BUS□M-B cable (made of quartz glass) is not affected by plasticizer.

- (10) If the adhesion of solvent and oil to the cord part of SSCNET III cable may lower the optical characteristic and machine characteristic. If it is used such an environment, be sure to do the protection measures to the cord part.
- (11) When keeping the Motion CPU or servo amplifier, be sure to put on a cap to connector part so that a dirt should not adhere to the end of SSCNET III connector.
- (12) SSCNET III connector to connect the SSCNET III cable is put a cap to protect light device inside connector from dust. For this reason, do not remove a cap until just before connecting SSCNET III cable. Then, when removing SSCNET III cable, make sure to put a cap.
- (13) Keep the cap and the tube for protecting light cord end of SSCNET III cable in a plastic bag with a zipper of SSCNET III cable to prevent them from becoming dirty.
- (14) When exchanging the Motion controller or servo amplifier, make sure to put a cap on SSCNET III connector. When asking repair of Motion controller or servo amplifier for some troubles, make also sure to put a cap on SSCNET III connector. When the connector is not put a cap, the light device may be damaged at the transit. In this case, exchange and repair of light device is required.

4.2.2 SSC I/F communication cable

(1) Precautions for handling the SSC I/F communication cable

- Do not stamp the SSC I/F communication cable.
- When laying the SSC I/F communication cable, be sure to secure the minimum cable bend radius of 30 mm(1.18 inch) or more.
If the bend radius is less than 30 mm(1.18 inch), it may cause malfunctions due to characteristic deterioration, wire breakage, etc.
- For installation or removal of the SSC I/F communication cable, hold surely a tab of cable connector.

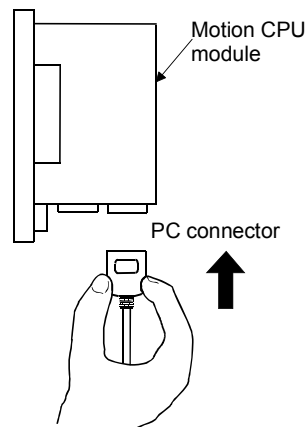

(2) Installation of the SSC I/F communication cable

- For installation of the SSC I/F communication cable to the Motion CPU, connect it to the PC connector of Motion CPU while holding a tab of SSC I/F communication cable connector. Be sure to insert it until it clicks.

(3) Removal of the SSC I/F communication cable

- For removal of the SSC I/F communication cable, pull out it while holding a tab of SSC I/F communication cable connector after making sure that the fixing hook have been removed completely.

POINT
Forcibly removal the SSC I/F communication cable from the Motion CPU module will damage the Motion CPU modules and SSC I/F communication cables.

4.2.3 Battery cable

(1) Precautions for handling the battery cable

- For installation or removal of the battery cable, hold surely a battery cable connector.

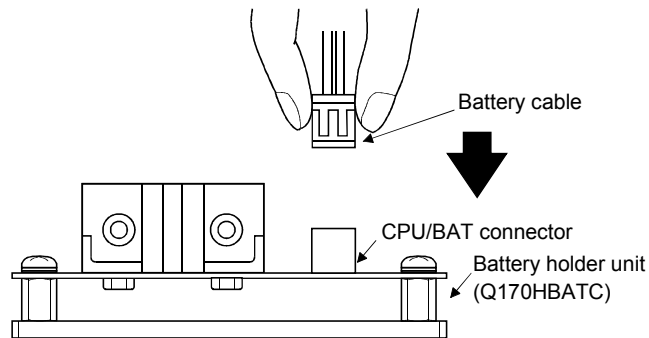

(2) Installation of the battery cable

- For installation of the battery cable to the Battery holder unit, connect it to the BAT connector of battery holder unit while holding the battery cable connector. Be sure to insert it until it clicks.

(3) Removal of the battery cable

- For removal of the battery cable, pull out it while holding the battery cable connector.

POINT
Forcibly removal the battery cable from the battery holder unit will damage the battery holder unit and battery cable.

4.2.4 Cable for teaching unit

(1) Precautions for handling the cable for teaching unit

- Do not stamp the cable for teaching unit.
- When laying the cable for teaching unit, be sure to secure the minimum cable bend radius of 30 mm(1.18 inch) or more.
If the bend radius is less than 30 mm(1.18 inch), it may cause malfunctions due to characteristic deterioration, wire breakage, etc.
- For installation or removal of the cable for teaching unit, hold surely a tab of cable connector.
- When the teaching unit is removed, the emergency stop and servomotor become coasting state.

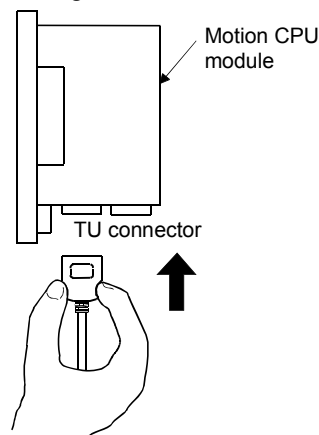

(2) Installation of the cable for teaching unit

- For installation of the cable for teaching unit to the Motion CPU (Q173HCPU-T/Q172HCPU-T), connect it to the TU connector of Motion CPU (Q173HCPU-T/Q172HCPU-T) while holding a tab of cable for teaching unit. Be sure to insert it until it clicks.

(3) Removal of the cable for teaching unit

- For removal of the cable for teaching unit, pull out the connector while holding a tab of connector connected to the TU connector of Motion CPU (Q173HCPU-T/Q172HCPU-T) after making sure that the fixing hook have been removed completely. (First be sure to remove the TU connector of Motion CPU (Q173HCPU-T/Q172HCPU-T for removal.)
If the connector of teaching unit is removed first, load may be applied and damaged to a connector of Motion CPU.

POINTS
(1) Forcibly removal the cable for teaching unit from the Motion CPU module will damage the Motion CPU modules and the cable for teaching unit.
(2) When the cable for teaching unit or short-circuit connector is connected to the connector for teaching unit, screw them to the connector for teaching unit. Under tightening can cause a drop, short circuit or operation failure.

 **CAUTION**

- When a teaching unit is removed, the emergency stop and servomotor become coasting state. In systems where coasting of the servomotor will be a problem, use dynamic brakes.

4.3 Installation of the Serial Absolute Synchronous Encoder

This section described instructions for handling the Serial absolute synchronous encoder (Q170ENC).

- (1) If the serial absolute synchronous encoder is linked to a chain, timing belt, or gears, the machine rotating shaft should be supported by a separate bearing and connected to Q170ENC through a coupling. Ensure that excessive force (greater than the permitted shaft load) is not applied to the shaft of Q170ENC.

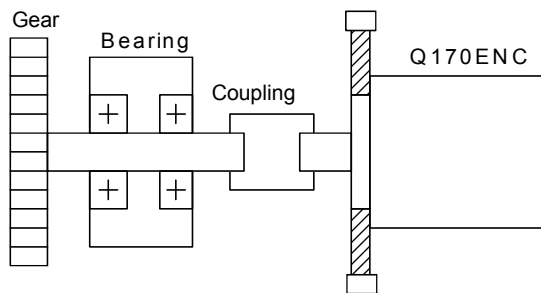

Fig. 4.1 Example of Encoder Linked to a Gear

Table 4.1 Permitted Shaft Loads

	Radial direction	Thrust direction
Permitted shaft load	Up to 19.6N	Up to 9.8N

- (2) Large errors in eccentricity and angle of deviation during installation can apply an excessive force to the Q170ENC shaft, which can cause deterioration in performance drastically reduce encoder service time. Minimize loads applied to the shaft such that they lie within the permitted shaft load range.

CAUTION

- The Q170ENC contains a glass disk and precision mechanism. Take care when handling it. The encoder performance may deteriorate if it is dropped or subjected to shocks or vibration exceeding the prescribed limits.
- Do not connect the shaft of Q170ENC directly to machine side rotary shaft. Always after connecting the shaft of Q170ENC to another bearing once, connect the shaft through a flexible coupling.

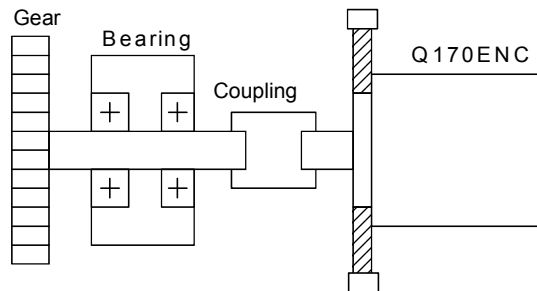

Fig 4.2 Connecting the shaft of Q170ENC to a machine side rotary shaft.

- Never hit the end of the Q170ENC coupling shaft with a hammer when connecting the coupling to it. The large loads applied to Q170ENC will damage it.
- The Q170ENC uses optical parts. Install it in an atmosphere where there are extremely few water drops and little oil and dust.
- In any place where the Q170ENC is exposed to water and/or oil, provide protection from oil and water, e.g. install a cover. In addition, run the cable downward to prevent oil and/or water from running on the cable into the Q170ENC. When it is inevitable to install the Q170ENC vertically or obliquely, trap for the cable.
- Use the Q170ENC within the specified temperature range (-5°C to 55°C (23 to 131°F)).

4 INSTALLATION AND WIRING

4.4 Wiring

4.4.1 Instructions for wiring

DANGER

- Completely turn off the all lines of the power supply externally before wiring. Not completely turning off all power could result in electric shock or damage to the product.
- When turning on the power supply or operating the module after wiring, be sure that the module's terminal covers are correctly attached. Not attaching the terminal cover could result in electric shock.

CAUTION

- Be sure to ground of the earth terminal FG and LG. Not doing so could result in electric shock or operation failure. (Ground resistance: 100Ω or less)
- When wiring in the Motion controller, be sure that it is done correctly by checking the product's rated voltage and the terminal layout. Connecting a power supply that is different from the rating or incorrectly wiring the product could result in fire or damage.
- External connections shall be crimped or pressure welded with the specified tools, or correctly soldered. Imperfect connections could result in short circuit, fire, or operation failure.
- Tighten the terminal screws within the specified torque range. If the terminal screws are loose, it could result in short circuit, fire, or operation failure. Tightening the terminal screws too far may cause damages to the screws and/or the module, resulting in drop, short circuit, or operation failure.
- Be sure there are no foreign matters such as sawdust or wiring debris inside the module. Such debris could cause fire, damage, or operation failure.
- The module has an ingress prevention label on its top to prevent foreign matter, such as wiring debris, from entering the module during wiring.
Do not remove this label during wiring.
Before starting system operation, be sure to remove this label because of heat dissipation.

This section described instructions for the wiring of the power supply.

(1) Power supply wiring

- (a) 100VAC, 200VAC and 24VDC wires should be twisted as dense as possible respectively. Connect the modules with the shortest distance.

Also, to reduce the voltage drop to the minimum, use the thickest wires possible.

Use the wires of the following core size for wiring.

Application	Recommended core size
100VAC, 200VAC, 24VDC wires	2.0mm ² or less
I/O equipment	0.75mm ² (0.75 to 1.5mm ² usable)
Ground wire	2.0mm ² or more

4 INSTALLATION AND WIRING

- (b) Do not bunch or lay them closely the main circuit (high voltage, large current) cables of the 100VAC and 24VDC with the I/O signal cables. If possible, separate them 100mm (3.94inch) or more away.
- (c) As a countermeasure to power surge due to thunder, connect a surge absorber for thunder as shown below.

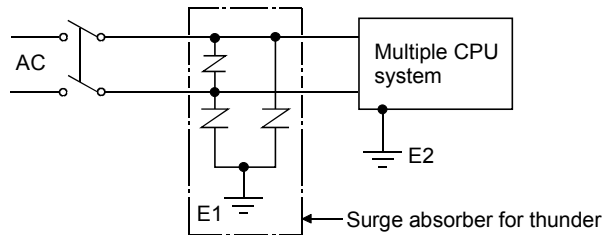

POINTS

- (1) Separate the ground of the surge absorber for thunder (E1) from that of the PLC (E2).
- (2) Select a surge absorber for thunder whose power supply voltage does not exceed the maximum allowable circuit voltage even if at the time of maximum power supply voltage elevation.

(2) Wiring of I/O equipment

- (a) Insulation-sleeved crimping terminals cannot be used with the terminal block.
It is recommended to cover the wire connections of the crimping terminals with mark or insulation tubes.
- (b) The wires used for connection to the terminal block should be 0.3 to 0.75mm² in core and 2.8mm (0.11inch) or less in outside diameter.
- (c) Run the input and output lines away from each other.
- (d) When the wiring cannot be run away from the main circuit and power lines, use a batch-shielded cable and ground it on the Motion controller side. In some cases, ground it in the opposite side.

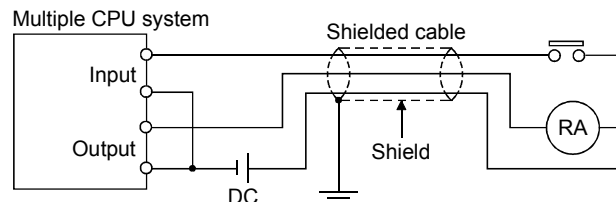

- (e) Where wiring runs through piping, ground the piping without fail.
- (f) Run the 24VDC input line away from the 100VAC and 200VAC lines.

4 INSTALLATION AND WIRING

- (g) Wiring of 200m (656.17ft.) or more distance will give rise to leakage currents due to the wiring capacity, resulting in a fault.

Refer to the troubleshooting chapter of the I/O Module User's Manual.

(3) Grounding

To ground the cable, follow the steps (a) to (c) shown below.

- (a) Use the dedicated grounding as independent as possible.
(Ground resistance: 100Ω or less)

- (b) When the Multiple CPU system and the another equipment cannot be departed to ground the cable each other, use (2) Common Grounding shown below.

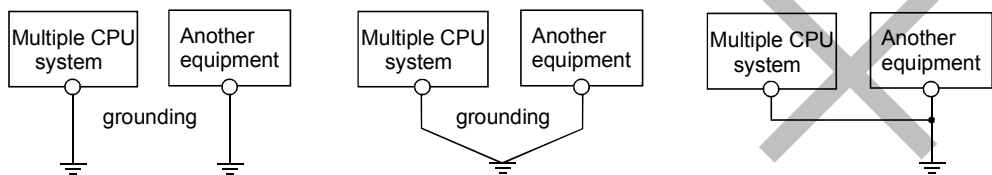

(1) Independent grounding.....Best (2) Common grounding.....Good (3) Joint grounding.....Not allowed

- (c) Use the grounding cable of 2 mm² or more.

Position the ground-contact point as nearly to the Multiple CPU system as possible, and use the total length of the grounding cable as short as possible.

4 INSTALLATION AND WIRING

4.4.2 Wiring to the power supply module

The following diagram shows the wiring example of power lines, grounding lines, etc. to the CPU and extension base units.

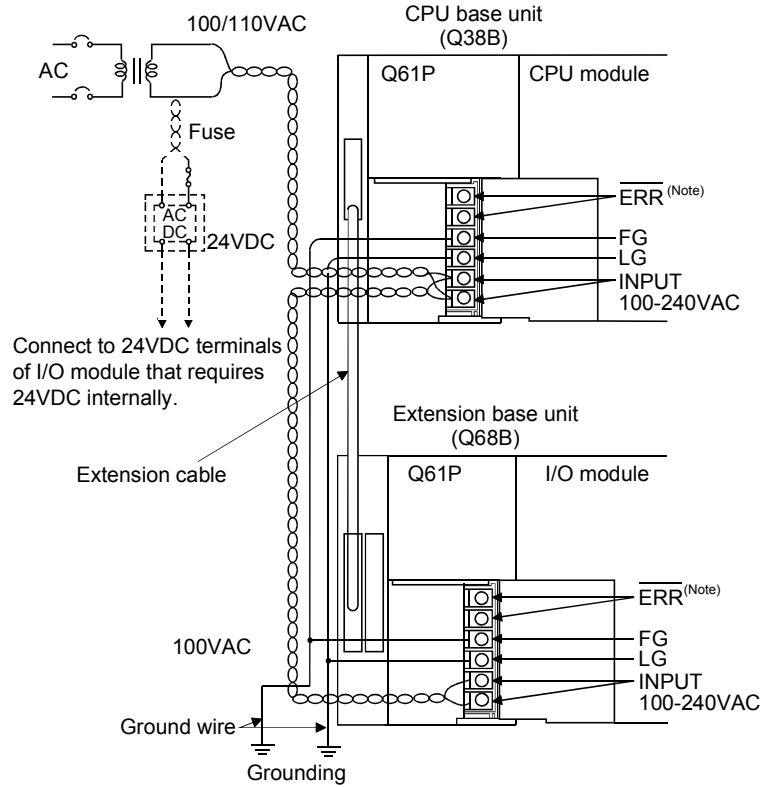

(Note) : The $\overline{\text{ERR}}$ terminal turns ON/OFF as described below.

<When the power supply module is mounted on the main base unit>

The terminal turns OFF (opens) when the AC power is not input, a CPU module stop error (including a reset) occurs, or the fuse of the power supply module is blown.

<When the power supply module is mounted on the extension base unit>

The terminal is always OFF(open).

POINT

- (1) Use the thickest possible (up to 2 mm²) wires for the 100/200 VAC and 24 VDC power cables. Be sure to twist these wires starting at the connection terminals. To prevent a short circuit should any screws loosen, use solderless terminals with insulation sleeves.
- (2) When the LG terminals and FG terminals are connected, be sure to ground the wires. Do not connect the LG terminals and FG terminals to anything other than ground. If LG terminals and FG terminals are connected without grounding the wires, the Motion controller may be susceptible to noise. In addition, since the LG terminals have potential of 1/2 input voltage, the operator may receive an electric shock when touching metal parts.
- (3) No system error can be detected by the $\overline{\text{ERR}}$ terminal of an extension base unit. ($\overline{\text{ERR}}$ terminal is always set off.)

4.4.3 Precautions of SSCNETⅢ cable wiring

SSCNETⅢ cable is made from optical fiber. If optical fiber is added a power such as a major shock, lateral pressure, haul, sudden bending or twist, its inside distorts or breaks, and optical transmission will not be available. Be sure to use optical fiber within the range of operating temperature described in this manual. Optical fiber melts down if being left near the fire or high temperature. Therefore, do not make it touched the part, which becomes high temperature, such as radiator or regenerative brake option of servo amplifier.

Read described item of this section carefully and handle it with caution.

(1) Minimum bend radius

When laying the SSCNETⅢ cable, be sure to secure the minimum cable bend radius or more.

If it is less than the minimum cable bend radius, it may cause malfunctions due to characteristic deterioration, wire breakage, etc.

Model name of SSCNETⅢ cable	Minimum bend radius[mm(inch)]
MR-J3BUS□M	25(0.98)
MR-J3BUS□M-A	Enforced covering cord : 50 (1.97) Code : 25 (0.98)
MR-J3BUS□M-B	Enforced covering cord : 50 (1.97) Code : 30 (1.18)

(2) Tension

If tension is added on the SSCNETⅢ cable, the increase of transmission loss occurs because of external force which concentrates on the fixing part of SSCNETⅢ cable or the connecting part of SSCNETⅢ connector. At worst, the breakage of SSCNETⅢ cable or damage of SSCNETⅢ connector may occur. For cable laying, handle without putting forced tension. (Refer to "APPENDIX1.1 SSCNETⅢ cables" for the tension strength.

(3) Lateral pressure

If lateral pressure is added on the SSCNETⅢ cable, the cable itself distorts, internal code gets stressed, and then transmission loss will increase. At worst, the breakage of optical cable may occur. As the same condition also occurs at cable laying, if the SSCNETⅢ cable is fixed, do not tighten up optical cable with a thing such as nylon band (TY-RAP).

(4) Twisting

If the SSCNETⅢ cable is twisted, it will become the same stress added condition as when local lateral pressure or bend is added. Consequently, transmission loss increases, and the breakage of optical fiber may occur at worst.

(5) Wiring process of SSCNET III cable

Put the SSCNET III cable in the duct or fix the cable at the closest part to the Motion CPU module with bundle material in order to prevent SSCNET III cable from putting its own weight on SSCNET III connector.
 Leave the following space for wiring.

• Putting in the duct

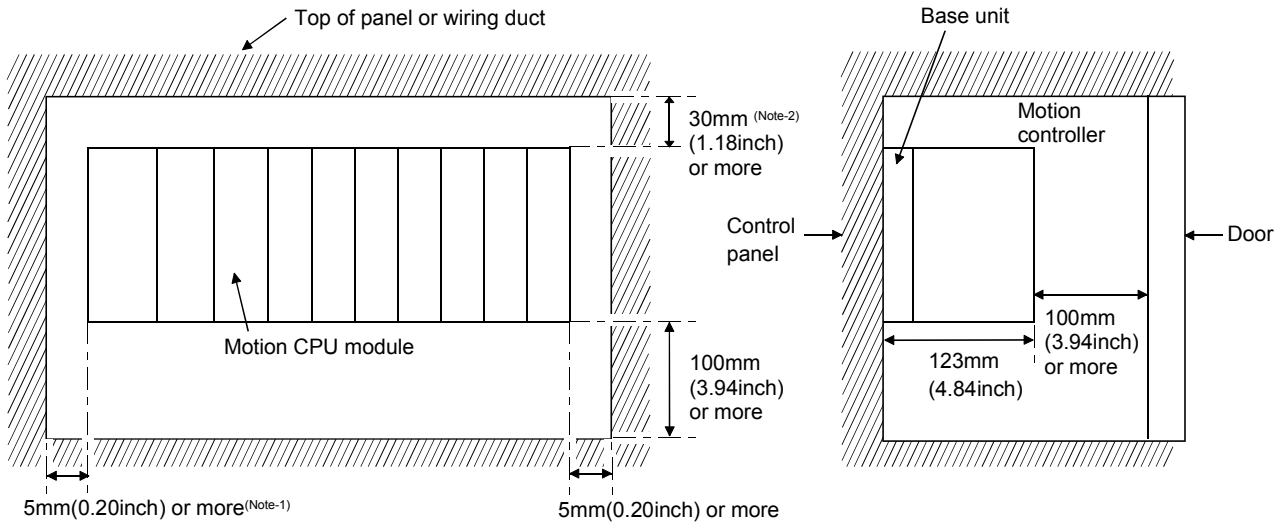

(Note-1): When the extension cable is connected without removing the adjacent module: 20[mm](0.79inch) or more
 (Note-2): When height of a wiring duct is 50[mm](1.97inch) or more: 40[mm](1.57inch) or more

• Bundle fixing

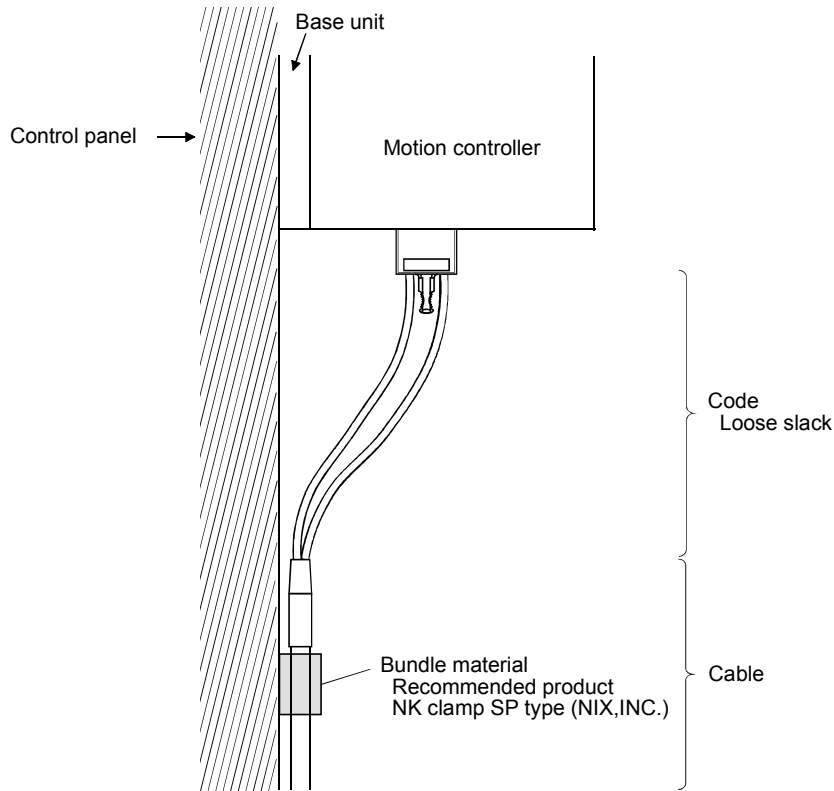

4 INSTALLATION AND WIRING

4.5 Installation/Wiring Checklist

At the worksite, copy the following table for use as a check sheet.

Item	Sub Item	Installation/wiring confirmation	Check
Installation of module	Installation of base unit	Check for looseness, rattling or distorted installation.	<input type="checkbox"/>
		Check that the fixing screw tightening torque is as specified.	<input type="checkbox"/>
		Check the unit for damage.	<input type="checkbox"/>
	Installation of modules to base unit	Check that the installation module model names are correct.	<input type="checkbox"/>
		Check that the Q173HCPU/Q172HCPU and PLC CPU are installed to the Motion CPU slots/PLC CPU slots.	<input type="checkbox"/>
		Check that the Q172LX/Q172EX and Q173PX are installed to the Motion CPU control slots.	<input type="checkbox"/>
		Check for looseness, rattling or distorted installation.	<input type="checkbox"/>
		Check that the module fixing screw tightening torque is as specified.	<input type="checkbox"/>
	Installation of battery holder unit	Check for looseness, rattling or distorted installation.	<input type="checkbox"/>
		Check that the module fixing screw tightening torque is as specified.	<input type="checkbox"/>
	Installation of synchronous encoder	Check that the amplitude, eccentricity and axial displacement relative to the machine side rotary shaft are within the permissible values.	<input type="checkbox"/>
		Check that a flexible coupling is used for coupling with the machine side rotary shaft.	<input type="checkbox"/>
		Check the module for damage.	<input type="checkbox"/>
		Check that excessive impact was not given during installation.	<input type="checkbox"/>
	Installation of teaching unit	Check the teaching unit for damage.	<input type="checkbox"/>
Check that the combination of teaching unit and connecting cable are correct.		<input type="checkbox"/>	
Wiring	Wiring of power supply modules and I/O modules wires	Check that the 100VAC, 200VAC and 24VDC wires are twisted as closely as possible respectively and run in the shortest distance.	<input type="checkbox"/>
		Check that the 100VAC, 200VAC and 24VDC wires are not bind the cable together with and run close to the power and I/O wires.	<input type="checkbox"/>
		Check that each wiring is of the specified wire size.	<input type="checkbox"/>
		Check for looseness of terminal block screw.	<input type="checkbox"/>
		Check that the terminal block screw tightening torque is as specified.	<input type="checkbox"/>
		Check that grounding of the earth terminal FG and LG.	<input type="checkbox"/>
	Wiring of SSCNET III cable	Check that SSCNET III cable model names for connection between Q173HCPU/Q172HCPU and servo amplifier/servo amplifier and servo amplifier are connect.	<input type="checkbox"/>
		Check for looseness, rattling or distorted connector and connective.	<input type="checkbox"/>
		Check that the minimum cable bend radius or more is secured.	<input type="checkbox"/>
		Check that the codes does not touch the wires or made from material which contains plasticizing material.	<input type="checkbox"/>
	Wiring of teaching unit cable	Check that the impossible power does not apply to the relay portion of cable attached teaching unit and cable connects CPU.	<input type="checkbox"/>
		Check that impossible power does not apply to the TU connector of Q173HCPU-T/Q172HCPU-T.	<input type="checkbox"/>

5. TRIAL OPERATION AND ADJUSTMENT

5.1 Checklist before Trial Operation

Table 5.1 Checklists before Trial Operation

Model name	Confirmation Items	Reference
Q173HCPU/Q172HCPU Motion CPU module	(1) Check that the battery lead connector is connected into the BAT connector of battery holder unit correctly.	2.4.10
	(2) Check that the battery voltage is normal. (Normal value: 3.0V)	2.4.10 (1)
Q172LX Servo external signals interface module/ Q172EX Serial absolute synchronous encoder interface module/	(1) Check that the installation position of module corresponds to the system setting.	Refer to the programming manual of operating system software.
	(2) Check that the external equipment are connected to the Q172LX/Q172EX/Q173PX correctly.	2.4.4 2.4.5 2.4.6
Q173PX Manual pulse generator interface module	(3) Check that the battery is connected to the battery connector.	6.4.2
	(4) Check that the battery voltage of Q172EX is normal. (Normal value: 3.6V)	2.4.5 (7)
CPU base unit	(1) Check that the installation module model names are correct.	2.4.3 (1)
	(2) Check that the installation orders are correct.	2.1.4
	(3) Check that the modules are installed correctly.	4.1.3 (1)
Power supply module	(1) Check that the power supply module model name installed on base unit is correct.	2.4.2 (1)
	(2) Check that FG and LG are wired correctly.	4.4.2
	(3) Check that the terminal screws are tightened correctly.	4.1.1 (3)
	(4) Check that the cable sizes are correct.	4.4.1 (1)
I/O module	(1) Check that the cables connected to each terminal of terminal block correspond to the signal names.	Refer to the I/O Module Type Building Block User's Manual
	(2) Check that the terminal screws are tightened correctly.	
	(3) Check that the cable sizes are correct.	
	(4) Check that the external power supply are connected correctly. (24 VDC, 5 VDC)	
Extension base unit	(1) Check that the installation module model names are correct.	2.4.3 (1) (b)
	(2) Check that the total I/O points of the I/O modules and special function module does not exceed the number I/O points of the CPU module.	Refer to the programming manual of operating system software.
	(3) Check that the installation modules are connected correctly.	4.1.3 (1)
SSCNET III cable	(1) Check that the installation SSCNET III cable model names are correct.	2.4.9
	(2) Check that the installation positions of the connector for SSCNET III cables are correct.	
	(3) Check that the SSCNET III cables are connected correctly.	
Battery holder unit (Q170HBATC)	(1) Check that the battery cables are connected correctly.	4.2.3
	(2) Check that the battery is connected to the battery connector.	6.4.2 (2)
SSC I/F communication cable	(1) Check that the installation SSC I/F communication cable model names are correct.	2.2
	(2) Check that the SSC I/F communication cables are connected correctly.	4.2.2
Teaching unit (A31TU-D3□/A31TU-DN□)	(1) Check that the combination of teaching unit and the connecting cable are correct.	2.4.8
	(2) Check that short-circuit connector for teaching unit is connected, when teaching unit is not using.	

5 TRIAL OPERATION AND ADJUSTMENT

5.2 Trial Operation and Adjustment Procedure

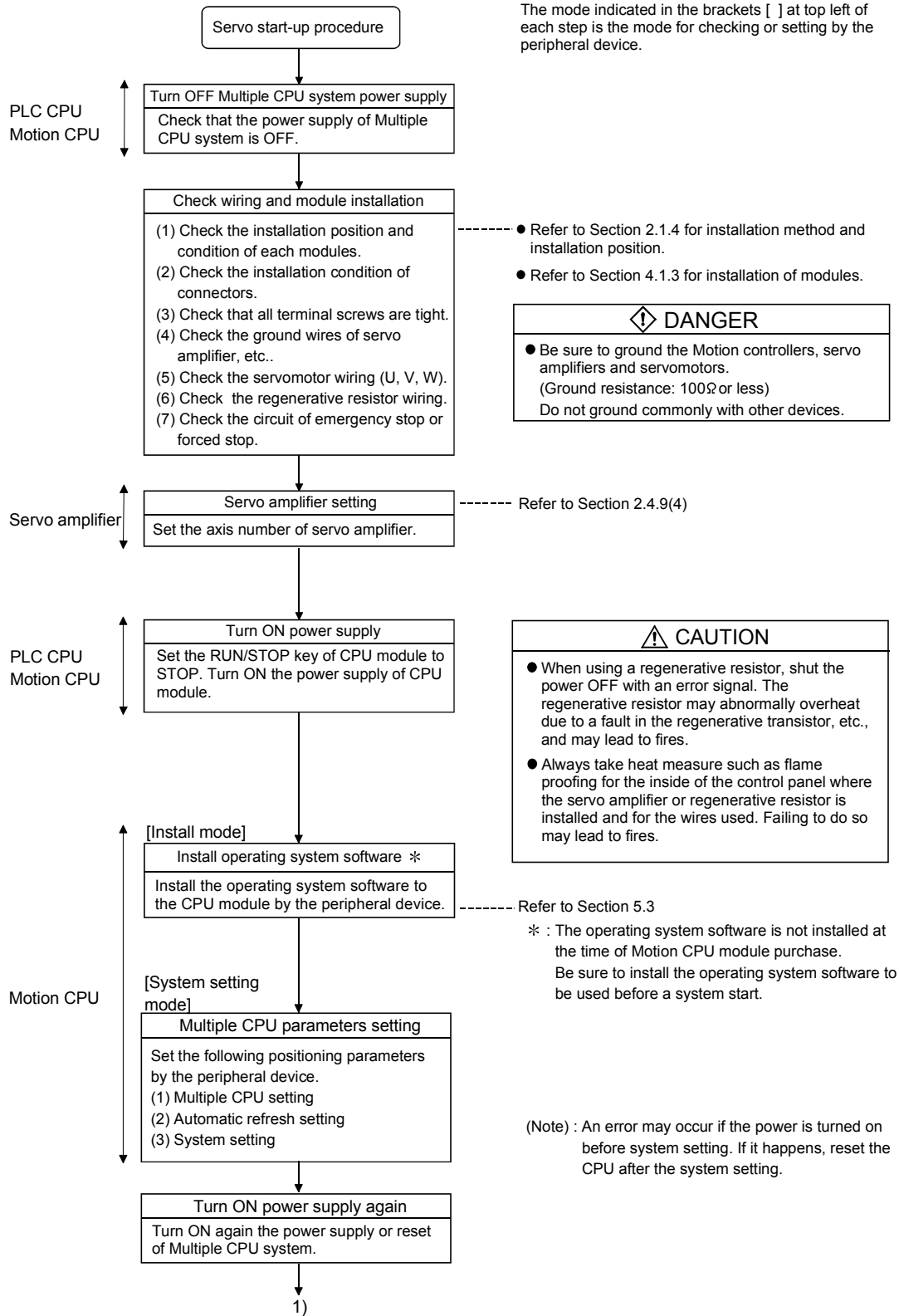

5 TRIAL OPERATION AND ADJUSTMENT

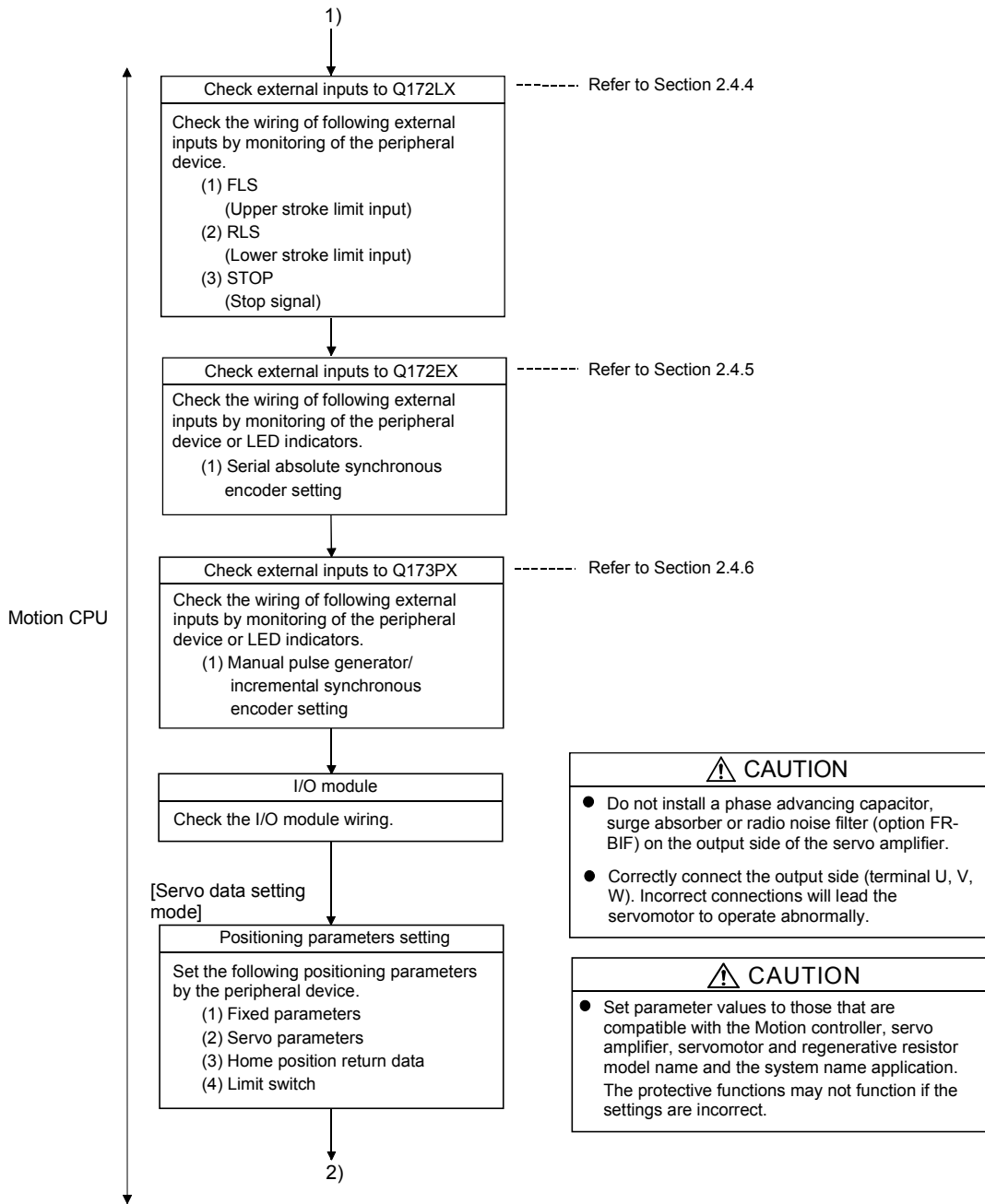

5 TRIAL OPERATION AND ADJUSTMENT

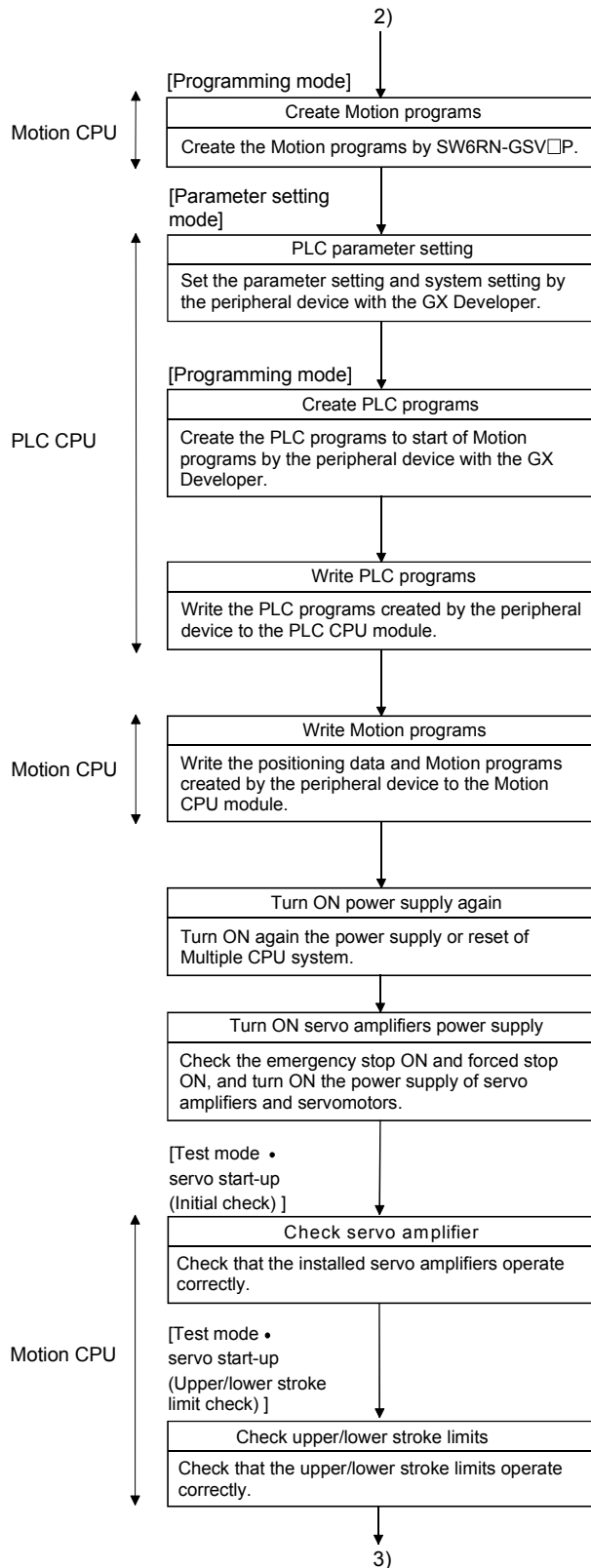

⚠ DANGER

- Never open the front case or terminal cover at times other than wiring work or periodic inspections even if the power is OFF. The insides of the Motion controller and servo amplifier are charged and may lead to electric shocks.
- When performing wiring work or inspections, turn the power OFF, wait at least ten minutes, and then check the voltage with a tester, etc.. Failing to do so may lead to electric shocks.
- Wire the units after installing the Motion controller, servo amplifier and servomotor. Failing to do so may lead to electric shocks or damage.

⚠ CAUTION

- Always install a leakage breaker on the Motion controller and servo amplifier power source.
- Install emergency stop circuit externally so that operation can be stopped immediately and the power shut off.
- Use the program commands for the program with the conditions specified in the instruction manual.
- Some devices used in the program have fixed applications, so use these with the conditions specified in the programming manual.

⚠ CAUTION

- If safety standards (ex., robot safety rules, etc.,) apply to the system using the Motion controller, servo amplifier and servomotor, make sure that the safety standards are satisfied.
- Construct a safety circuit externally of the Motion controller or servo amplifier if the abnormal operation of the Motion controller or servo amplifier differ from the safety directive operation in the system.

----- Axis No. and error description of servo amplifier which detected errors are displayed on initial check screen.

5 TRIAL OPERATION AND ADJUSTMENT

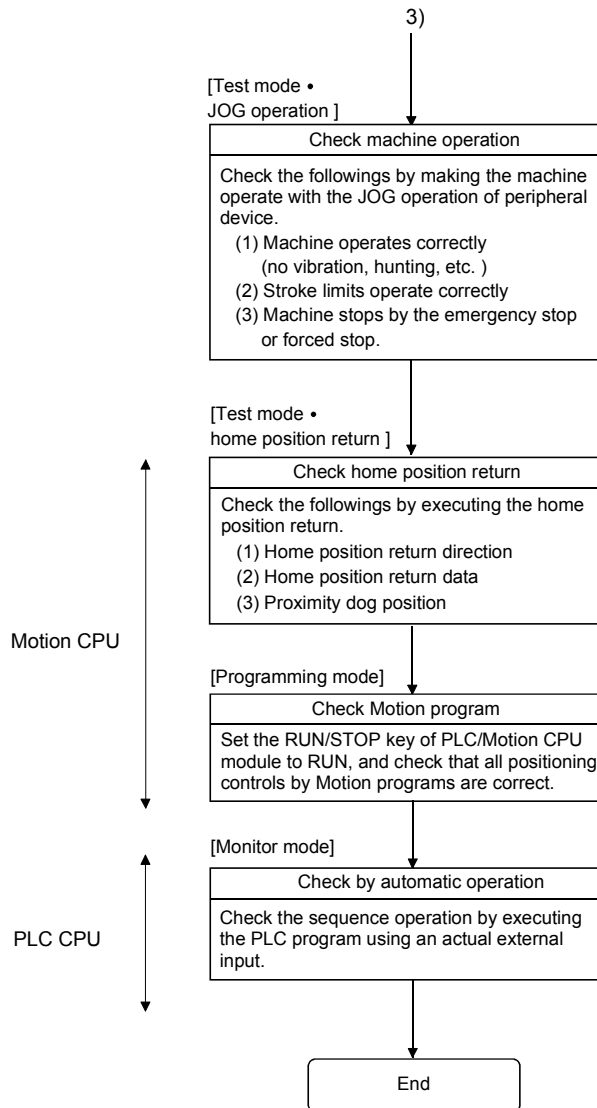

CAUTION
<ul style="list-style-type: none"> ● The system must have a mechanical allowance so that the machine itself can stop even if the stroke limits switch is passed through at the max. speed.

POINTS	<ol style="list-style-type: none"> (1) Make note of motor module names before the motor is installed on a machine. The motor name plate may not be visible after the motor is installed. (2) When the servo amplifier, servomotor is first turned on, check the operation before the servomotor is installed on a machine to avoid an unexpected accidents such as machine breakage.
---------------	--

5.3 Operating System Software Installation Procedure

The operating system software must be installed to the Motion CPU module by using the peripheral device and programming software package.

The installation procedure is shown below.

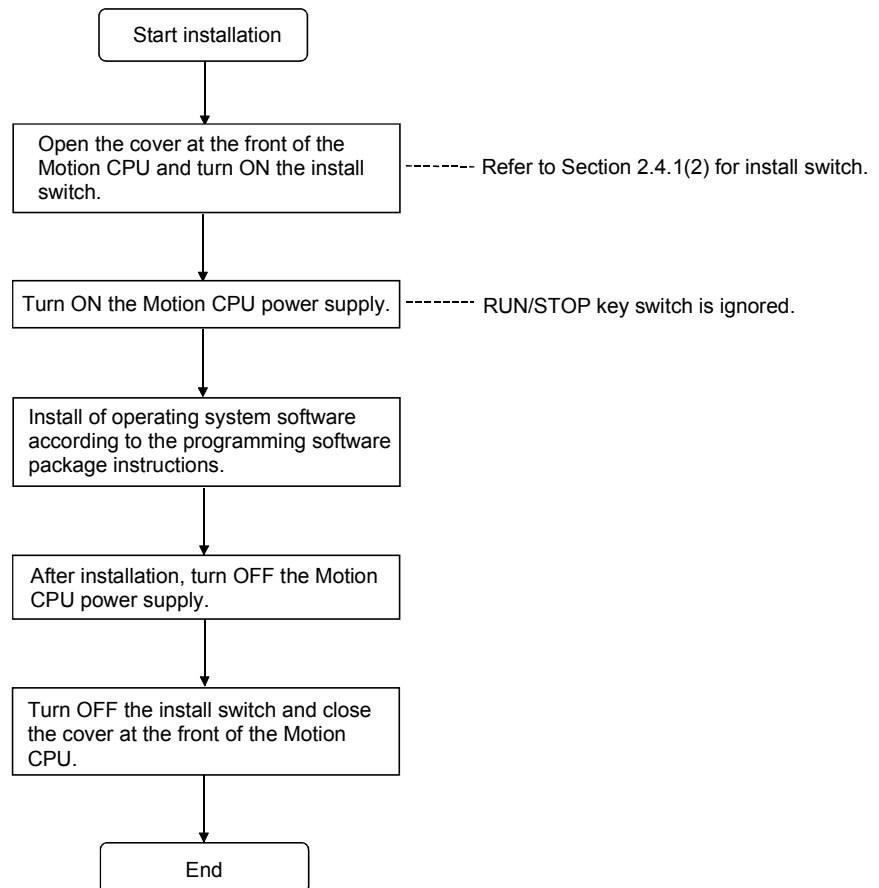

POINTS

- (1) The operating system software was not installed at the time of Motion CPU module purchase. Be sure to install the operating system software to be used before a system start.
- (2) Even if the operating system software is installed, the positioning data and servo programs written in the Motion CPU module does not be rewritten.
- (3) Do not turn off the power supply during installation. The Motion CPU module may break down.
- (4) When the operating system software is installed at set the multiple not installed Motion CPU modules in one base unit, be sure to turn ON the install switches of all not installed Motion CPU modules to install.
(Note): If the power supply is turned ON in the state of the install switch OFF of all not installed Motion CPU modules, it does not operate normally. Be sure to install the operating system software before system start.

5 TRIAL OPERATION AND ADJUSTMENT

5.4 Trial Operation and Adjustment Checklist

At the worksite, copy the following table for use as a check sheet.

Work Step	Item	Trial Operation and Adjustment Confirmation	Check
Before power supply ON	Installation of unit/module and basic wiring	Check that the each module is installed correctly.	<input type="checkbox"/>
		Check that the each connector is connected correctly.	<input type="checkbox"/>
		Check the each terminal screw for looseness.	<input type="checkbox"/>
		Check that the earth wires of power supply module or servo amplifiers, etc. are correct.	<input type="checkbox"/>
		Check that the servomotor wiring is correct.	<input type="checkbox"/>
		Check that the regenerative option wiring are correct.	<input type="checkbox"/>
		Check that the circuit of emergency stop and forced stop are correct.	<input type="checkbox"/>
Power supply ON/ Motion CPU module in STOP status/ PLC CPU module in STOP status	OS installation	Check that the operating system software is compatible.	<input type="checkbox"/>
	System setting	Check that the system setting is correct.	<input type="checkbox"/>
	Q172LX external signals	Check that the upper/lower stroke limit inputs are correct.	<input type="checkbox"/>
		Check that the STOP signal input is correct.	<input type="checkbox"/>
	Program/ positioning data	Check that the proximity dog and speed/position switching signal inputs are correct.	<input type="checkbox"/>
		Check that the Motion program, PLC program and positioning data are stored in the PLC/Motion CPU module correctly.	<input type="checkbox"/>
		Check the communications with servo amplifiers.	<input type="checkbox"/>
Motion CPU module in RUN status/ PLC CPU module in STOP status	Basic axis operations (Check each axis)	Check that the rotation direction for JOG operation is correct.	<input type="checkbox"/>
		Check that the upper/lower limit switches operate correctly.	<input type="checkbox"/>
		Check that the rotation at maximum command speed is motor rating or less.	<input type="checkbox"/>
		Check that the machine operates correctly by the JOG operation.	<input type="checkbox"/>
		Check that the machine stops by the upper/lower stroke limit.	<input type="checkbox"/>
		Check that the machine stops by the emergency stop or forced stop.	<input type="checkbox"/>
		Check that the home position return is executed correctly.	<input type="checkbox"/>
Motion CPU module in RUN status/ PLC CPU module in RUN status	Manual operation	Check that each positioning control of Motion program is operates correctly.	<input type="checkbox"/>
		Check the each operation in manual operation mode of system during Motion program execution.	
		Check that the machine operation stops immediately by the emergency stop or forced stop.	<input type="checkbox"/>
		Check the operation of each actuator and confirmation limit switch.	<input type="checkbox"/>
		Check that the emergency stop, forced stop and equipment alarm signals are correct.	<input type="checkbox"/>
	Automatic operation	Checks in compliance with control specifications specific to system and equipment.	<input type="checkbox"/>
		Check the each operation in manual operation mode of system during Motion program execution.	
		Check that the automatic operation motions.	<input type="checkbox"/>
		Check that the machine operation stops immediately by the emergency stop or forced stop.	<input type="checkbox"/>
		Check that the module or equipment alarm causes an immediate stop or cycle stop.	<input type="checkbox"/>
		Check that the restoring operation can be performed after an alarm stop.	<input type="checkbox"/>
	Torque check	Make other checks in compliance with control specifications specific to system and equipment.	<input type="checkbox"/>
Check that the acceleration/deceleration torque is maximum torque or less.		<input type="checkbox"/>	
		Check that the continuous effective load torque is rated torque or less.	<input type="checkbox"/>

6. INSPECTION AND MAINTENANCE

 **DANGER**

- Do not touch the terminals while power is on. Doing so could cause electric shock.
- Correctly connect the battery. Also, do not charge, disassemble, heat, place in fire, short circuit, or solder the battery.
Mishandling of a battery may cause overheating, cracks or ignition which could result in injury and fire.
- Turn off the all lines of the power supply externally when cleaning the module, tightening the terminal screws or module fixing screws. Not doing so could result in electric shocks.
Under tightening the terminal screws may cause a drop, short circuit or operation failure. Over tightening may cause a drop, short circuit or operation failure due to damage to the screw or module.

 **CAUTION**

- Read the manual carefully and pay careful attention to safety for the on-line operation (especially program change, forced stop or operation change) performed by connecting peripheral devices to the CPU module during operation.
Erroneous operation may cause machine breakage or accident.
- Never try to disassemble or modify module. It may cause product failure, operation failure, injury or fire.
- When using cellular phone, keep them away from the Motion controller 25 cm (9.84 inch) or more.
It may cause an operation failure.
- Turn off the all lines of the power supply externally when installing or removing the modules. Not doing so could damage the module or result in operation failure.

In order that you can use the Motion controller in normal and optimal condition at all times, this section describes those items that must be maintained or inspected daily or at regular intervals.

6.1 Maintenance Works

6.1.1 Instruction of inspection works

In order that can use the Motion controller in safety and normal, those items that must be inspected list below.

CAUTION

- Never open the front case or terminal covers while the power is ON or the unit is running, as this may lead to electric shocks.
- Never run the unit with the front case or terminal cover removed. The high voltage terminal and charged sections will be exposed and may lead to electric shocks.
- Never remove the front case or terminal cover at times other than wiring work or periodic inspections even if the power is OFF. The insides of the Motion controller and servo amplifier are charged and may lead to electric shocks.
- When performing wiring work or inspections, turn the power OFF, wait at least ten minutes, and then check the voltage with a tester, etc.. Failing to do so may lead to electric shocks.
- Be sure to ground the Motion controller, servo amplifier and servomotor. Do not ground commonly with other devices. (Ground resistance : 100 Ω or less)
- The wiring work and inspections must be done by a qualified technician.
- Wire the units after installing the Motion controller, servo amplifier and servomotor. Failing to do so may lead to electric shocks or damage.
- Never operate the switches with wet hands, as this may lead to electric shocks.
- Do not damage, apply excessive stress, place heavy things on or sandwich the cables, as this may lead to electric shocks.
- Do not touch the Motion controller, servo amplifier or servomotor terminal blocks while the power is ON, as this may lead to electric shocks.
- Do not touch the built-in power supply, built-in grounding or signal wires of the Motion controller and servo amplifier, as this may lead to electric shocks.
- Perform the daily and periodic inspections according to the instruction manual.
- Perform maintenance and inspection after backing up the program and parameters for the Motion controller and servo amplifier.
- Do not place fingers or hands in the clearance when opening or closing any opening.
- Periodically replace consumable parts such as batteries according to the instruction manual.
- Do not touch the lead sections such as ICs or the connector contacts.
- Do not place the Motion controller or servo amplifier on metal that may cause a power leakage or wood, plastic or vinyl that may cause static electricity buildup.
- Do not perform a megger test (insulation resistance measurement) during inspection.
- When replacing the Motion controller or servo amplifier, always set the new unit settings correctly.
- After maintenance and inspections are completed, confirm that the position detection of the absolute position detector function is correct.

⚠ CAUTION

- Do not short circuit, charge, overheat, incinerate or disassemble the batteries.
- The electrolytic capacitor will generate gas during a fault, so do not place your face near the Motion controller or servo amplifier.
- The electrolytic capacitor and fan will deteriorate. Periodically change these to prevent secondary damage from faults. Replacements can be made by our sales representative.
- If an error occurs in the self diagnosis of the Motion controller or servo amplifier, confirm the check details according to the instruction manual, and restore the operation.
- If a dangerous state is predicted in case of a power failure or product failure, in order to prevent that state, use a servomotor with electromagnetic brakes for maintenance or install a brake mechanism externally.
- Use a double circuit construction so that the electromagnetic brake operation circuit can be operated by emergency stop signals set externally.

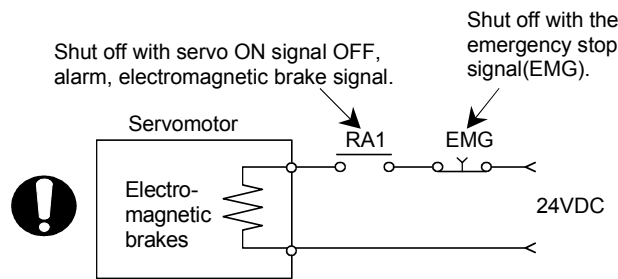

- If an error occurs, remove the cause, secure the safety and then resume operation after alarm release.
- The unit may suddenly restart after a power failure is restored, so do not go near the machine. (Design the machine so that personal safety can be ensured even if the machine restarts suddenly.)
- Confirm and adjust the program and each parameter before operation. Unpredictable movements may occur depending on the machine.
- Extreme adjustments and changes may lead to unstable operation, so never make them.
- Do not apply a voltage other than that specified in the instruction manual on any terminal. Doing so may lead to destruction or damage.
- Do not mistake the terminal connections, as this may lead to destruction or damage.
- Do not mistake the polarity (+ / -), as this may lead to destruction or damage.
- Do not touch the servo amplifier's heat radiating fins, regenerative resistor and servomotor, etc., while the power is ON and for a short time after the power is turned OFF. In this timing, these parts become very hot and may lead to burns.
- Always turn the power OFF before touching the servomotor shaft or coupled machines, as these parts may lead to injuries.
- Do not go near the machine during test operations or during operations such as teaching. Doing so may lead to injuries.
- Do not bunch the control wires or communication cables with the main circuit or power wires, or lay them closely. They should be installed 100 mm (3.94 inch) or more from each other. Trying to bunch or install could result in noise that would cause operation failure.

6 INSPECTION AND MAINTENANCE

6.2 Daily Inspection

The items that must be inspected daily are listed below.

Table 6.1 Daily Inspection

Item	Inspection item	Inspection	Criterion	Action			
1	Installation of the base unit	Check that the fixing screws are not loose and the cover is not dislocated.	The screws and cover must be installed correctly.	Retighten the screws.			
2	Installation of the I/O module, etc.	Check that the module is not dislocated and the unit fixing hook is engaged correctly.	The module fixing hook must be engaged and installed correctly.	Correctly engaged the unit fixing hook.			
3	Connecting condition	Check that terminal screws are not loose.	Screws should not be loose.	Retighten the terminal screws.			
		Check distance between of crimping terminals.	Crimping terminals must be positioned at proper intervals.	Correct.			
		Check the connector part of the cable.	Connector must not be loose.	Retighten the connector fixing screws.			
4	Module indication LED	Power supply module	[POWER] LED	Check that the LED is ON.	The LED must be ON (green). (Abnormal if the LED is OFF or ON (red)).	Refer to "QCPU User's Manual (Function Explanation, Program Fundamentals)".	
			PLC CPU module	[MODE] LED <small>(Note-1)</small>	Check that the LED is ON.		The LED must be OFF. (Abnormal if the LED is ON or flickers.)
				[RUN] LED	Check that the LED is ON in RUN state.		The LED must be ON. (Abnormal if the LED is OFF.)
		[ERR.] LED		Check that the LED is OFF.	The LED must be OFF. (Abnormal if the LED is ON or flickers.)		
		[BAT.] LED <small>(Note-2)</small>		Check that the LED is OFF.	The LED must be OFF. (Abnormal if the LED is ON.)		
		Motion CPU module	[MODE] LED	Check that the LED is ON.	The LED must be ON (green). The LED must be ON (orange) in the Installation mode • Mode written in ROM. (Abnormal if the LED is OFF.)		Refer to Section 2.4.1
			[RUN] LED	Check that the LED is ON.	The LED must be ON. (Abnormal if the LED is OFF.)		
			[ERR.] LED	Check that the LED is OFF.	The LED must be OFF. (Abnormal if the LED is ON or flickers.)		
			[M.RUN] LED	Check that the LED is ON in RUN state.	The LED must be ON during operation in motion control. (Abnormal if the LED is OFF.)		
			[BAT.] LED	Check that the LED is OFF.	The LED must be OFF. (Abnormal if the LED is ON.)		
		[BOOT] LED	Check that the LED is ON/OFF.	The LED must be ON in the mode operated by ROM. The LED must be OFF in the mode operated by RAM/Installation mode • Mode written in ROM.			
		Module indication LED	I/O module	Input LED	Check that the LED is ON/OFF.	The LED must be ON at input signal ON. The LED must be OFF at input signal OFF. (Abnormal if the LED does not turn ON or turn OFF as indicated above.)	Refer to "I/O Module Type Building Block User's Manual".
				Output LED	Check that the LED is ON/OFF.	The LED must be ON at output signal ON. The LED must be OFF at output signal OFF. (Abnormal if the LED does not turn ON or turn OFF as indicated above.)	

(Note-1) : The Q00CPU/Q01CPU dose not have the "MODE"LED.

(Note-2) : The Q00CPU/Q01CPU dose not have the "BAT."LED.

6 INSPECTION AND MAINTENANCE

6.3 Periodic Inspection

The items that must be inspected one or two times every 6 months to 1 year are listed below. When the equipment is moved or modified, or layout of the wiring is changed, also implement this inspection.

Table 6.2 Periodic Inspection

Item	Inspection item	Inspection method	Criterion	Action
1	Ambient environment	Measure with a thermometer and a hygrometer. Measure corrosive gas.	0 to 55 °C (32 to 131 °F)	If the controller is used in the control panel, temperature within the control panel is equivalent to ambient temperature.
	Ambient humidity		5 to 95 % RH	
	Atmosphere		No corrosive gases	
2	Power voltage	Measure a voltage across the terminals of 100/200VAC and 24VDC.	85 to 132VAC	Change the power supply.
			170 to 264VAC	
			15.6 to 31.2VDC	
3	Installation	Move the module to check for looseness and rattling. Check visually.	The module must be installed fixedly.	Retighten the screws. If the CPU, I/O, or power supply module is loose, fix it with screws.
	Looseness, rattling		Dirt and foreign matter must not be present.	Remove and clean.
4	Connection	Looseness of terminal screws	Try to further tighten screws with a screwdriver.	Screws must not be loose. Further tighten.
		Distance between of crimping terminals	Check visually.	Crimping terminals must be positioned at proper intervals. Correct.
		Looseness of connectors	Check visually.	Connectors must not be loose. Retighten the connector fixing screws.
5	Battery	Preventive maintenance		Even if the lowering of a battery capacity is not shown, replace the battery with a new one if a service life time of the battery is exceeded.

6.4 External Battery

The special relays (M9006, M9007) turn ON due to the Motion CPU program or the decrease in voltage of memory back-up battery.

Even if these special relays turn ON, the program and the contents of memory back-up are not erased immediately.

However, if these relays are overlooked, the contents may be erased.

While a total of the memory back-up time after the M9006, M9007 turn ON is within a specified time, replace the battery with a new one.

POINT

M9007 turns ON due to the decrease in voltage of battery. Even if M9007 turns ON, it holds the data within a specified time.
--

However, for safety, replace the battery with a new one as soon as possible.
--

When the external battery voltage is lowered, the M9006 and M9007 turn ON.

M9006 always detects the battery decrease, and it turns ON when the battery voltage becomes normal.

M9007 detects the battery decrease, and it holds an alarm until the power supply is turned ON again or reset even if the battery voltage becomes normal.

Set the available/not available of external battery in the system settings.

6 INSPECTION AND MAINTENANCE

6.4.1 Battery service life time

(1) Q173HCPU/Q172HCPU, Q172EX module battery service life time

The battery service life time corresponding to the type is shown below.

Type	Classification		Battery service life time (Total power failure time) [h] (Note-1)		
			Guaranteed time (MIN)	Actual time (TYP)	After the battery decrease
Q173HCPU/ Q172HCPU	Internal rechargeable battery (Note-3)	Charging time: 8 hours or more	200	500	No battery decrease detection
		Charging time: 40 hours or more	1100	4300	
	External battery (Q6BAT) (Note-2)		60000	240000	120 (After M9006, M9007 on)
Q172EX	Internal battery (A6BAT/MR-BAT)	Q170ENC×1	8000	24000	40 (After Error code 1152)
		Q170ENC×2	4000	12000	

(Note-1) : The actual time in use means the averaged time, and the guaranteed time means the minimum time.

(Note-2) : The external battery for Q173HCPU/Q172HCPU is installed to the Battery holder unit(Q170HBATC).

(Note-3) : The internal rechargeable battery for Q173HCPU/Q172HCPU can not be replaced.

Even if the Q6BAT/A6BAT/MR-BAT is not connected to the Q173HCPU/Q172HCPU/Q172EX or a total power failure time does not exceed the guaranteed value, replace it with a new one in 4 to 5 years.
If a total of power failure time exceeds the guaranteed value specified above the M9006, M9007 is turned on, replace the battery with a new one immediately.

6.4.2 Battery replacement procedure

(1) Q172EX module battery replacement procedure

When the Q172EX module battery has been exhausted, replace the battery with a new one in accordance with the procedure shown below. Before removing the battery, turn ON the power supply for 10 minutes or longer.

Even when the battery is removed, the memories are backed up by the capacitor for a while. However, if the replacement time exceeds the guaranteed value specified in the table below, the contents stored in the memories may be erased. To prevent this trouble, replace the battery speedily.

Backup time by capacitor
Backup time by capacitor[min]
3

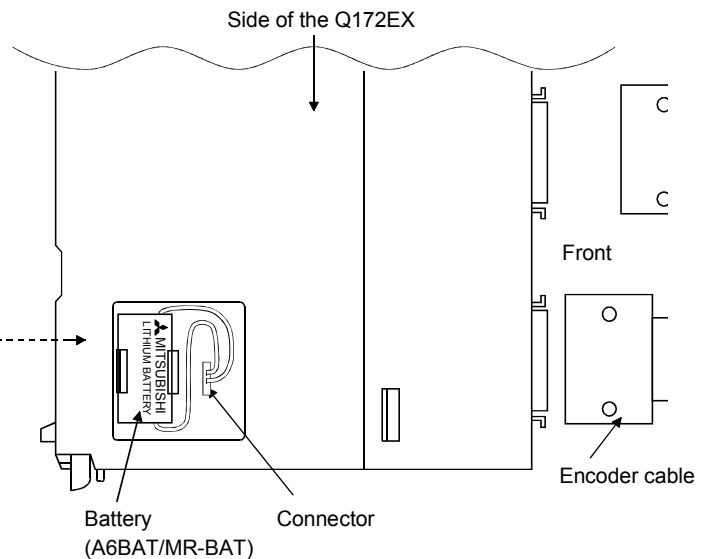
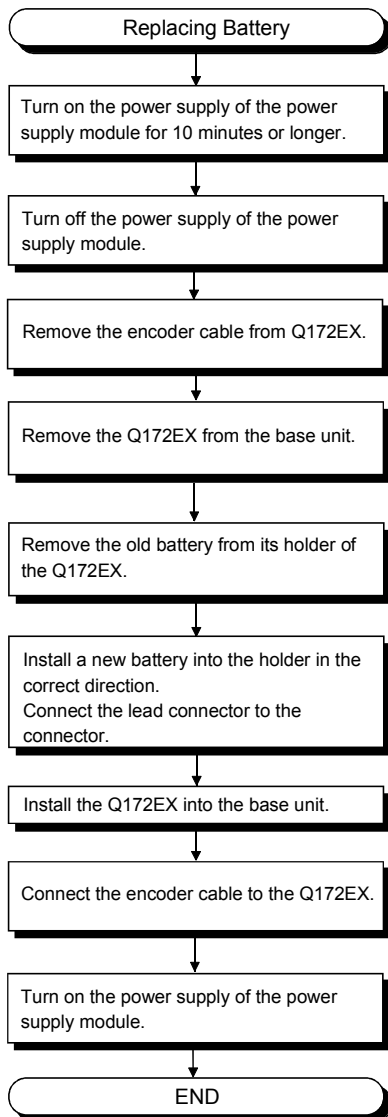

- (2) Battery replacement procedure of the Battery holder unit
 When the battery has been exhausted, replace the battery with a new one in accordance with the procedure shown below.

POINTS
Replace the battery taking care of the following. (1) Start the replacement operation after backing up the data to the personal computer which is installed the SW6RN-GSV□P. (2) Firstly back up the data stored in the Motion CPU to the personal computer which is installed the SW6RN-GSV□P then replace the battery with a new one. After installation the battery in the Battery holder unit, verify the backing up the data to the personal computer which is installed the SW6RN-GSV□P and the data in the Motion CPU module, confirm the data is not changing.

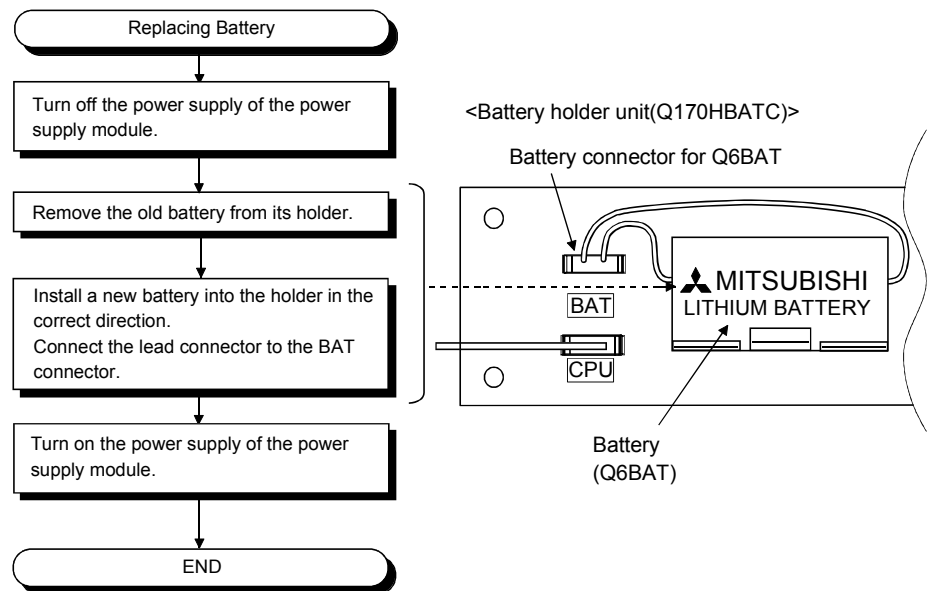

6.5 Discard of internal rechargeable battery

(1) Discard procedure of internal rechargeable battery

The rechargeable lithium battery is built-in in the Motion CPU module. When you discard the Motion CPU module, discard an internal rechargeable battery according to the following procedure.

Discard procedure

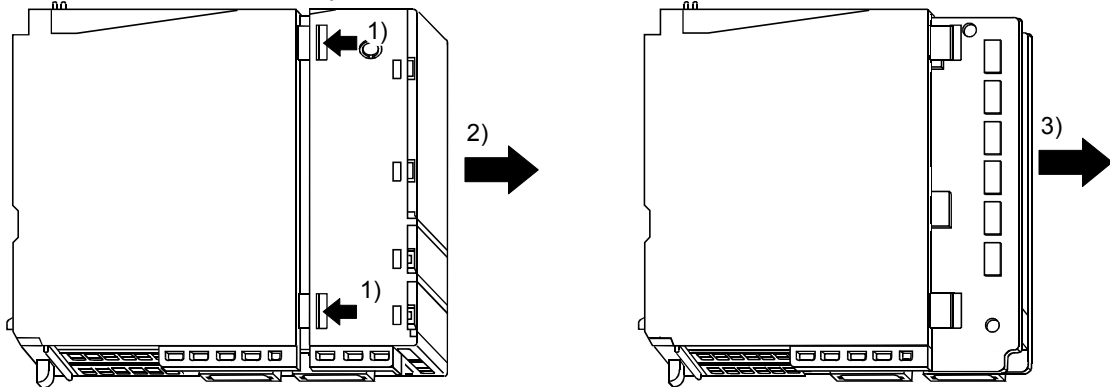

1) 2) Push in 4 hooks of the Motion CPU module side and remove a front cover.

3) Take out a printed circuit board from a case.

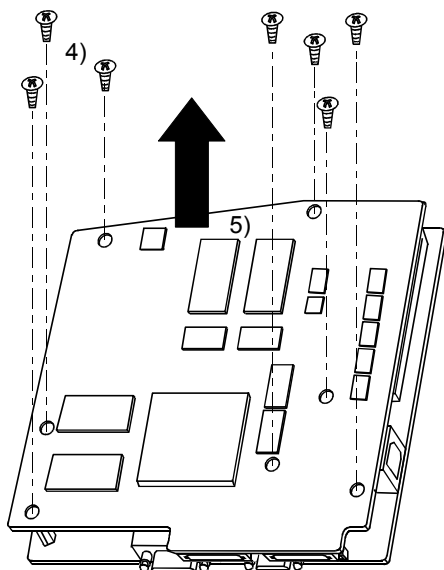

4) Turn up a printed circuit board which has install the SSCNET III connector, and then remove 7 fixing screws (M3) from circuit board.

5) Separate printed circuit boards.

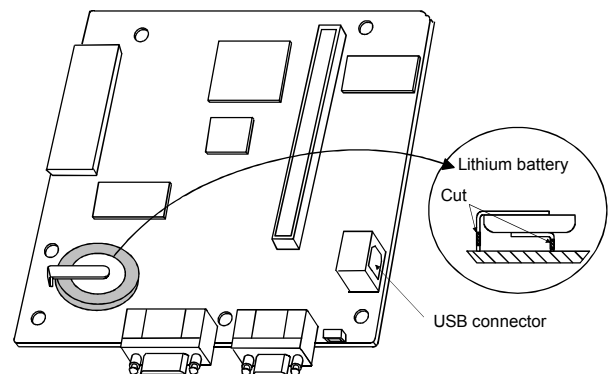

6) Check that the internal rechargeable battery is set on a surface of printed circuit board which has install the USB connector, and cut lead sections of internal rechargeable battery.

7) When you discard an internal rechargeable battery, please follow the law of each country (area).

CAUTION

- Do not disassemble the modules except the time of discard.
- Do not short circuit, charge, overheat, incinerate or disassemble the batteries.

6.6 Troubleshooting

This section describes the various types of trouble that occur when the system is operated, and causes and corrective actions of these troubles.

6.6.1 Basics of troubleshooting

In order to increase the reliability of the system, not only highly reliable devices are used but also the speedy startup of the system after the occurrence of trouble becomes an important factor.

To start up the system speedily, the cause of the trouble must be located and eliminated correctly.

The basic three points that must be followed in the troubleshooting are as follows.

(1) Visual inspection

Visually check the following.

- (a) Movement of machine (stopped condition, operating condition)
- (b) Power supply on/off
- (c) State of I/O devices
- (d) Installation condition of the Power supply module, Q173HCPU/Q172HCPU module, PLC CPU module, I/O module, Q172LX/Q172EX/Q173PX Motion module, SSCNETⅢ cable, SSC I/F communication cable, Synchronous encoder cable and cable for the teaching unit.
- (e) State of wiring (I/O cables, cables)
- (f) Display states of various types of indicators (MODE LED, RUN LED, M.RUN LED, ERR. LED, I/O LED, etc.)
- (g) Setting states of various types of set switches (Number of extension bases setting, memory back-up, etc.)

After confirming items (a) to (g), Motion CPU module connect the SW6RN-GSV□P, PLC CPU module connect the GX Developer and check the operating conditions of the servomotors and the error code.

(2) Check of trouble

Check to see how the operating condition varies while the Motion controller is operated as follows.

- (a) Set the RUN/STOP switch to STOP.
- (b) Reset the trouble with the RESET/L.CLR switch.
- (c) Turn ON and OFF the power supply.

(3) Reduction in area

Estimate the troubled part in accordance with items (1) and (2) above.

- (a) Multiple CPU system or external devices?
- (b) Motion CPU or PLC CPU?
- (c) I/O module or others?
- (d) Servo program or Motion SFC program?
- (e) PLC program?

6.6.2 Troubleshooting of Motion CPU module and I/O modules

This section describes the contents of troubles for the error codes and corrective actions of the troubles.

As for troubleshooting of PLC CPU, refer to the QCPU User's Manual (Function Explanation, Program Fundamentals) of their respective modules.

POINT
Check that the operating system software is installed at the time of Motion CPU module start.

(1) Troubleshooting flowchart

The followings show the contents of the troubles classified into a variety of groups according to the types of events.

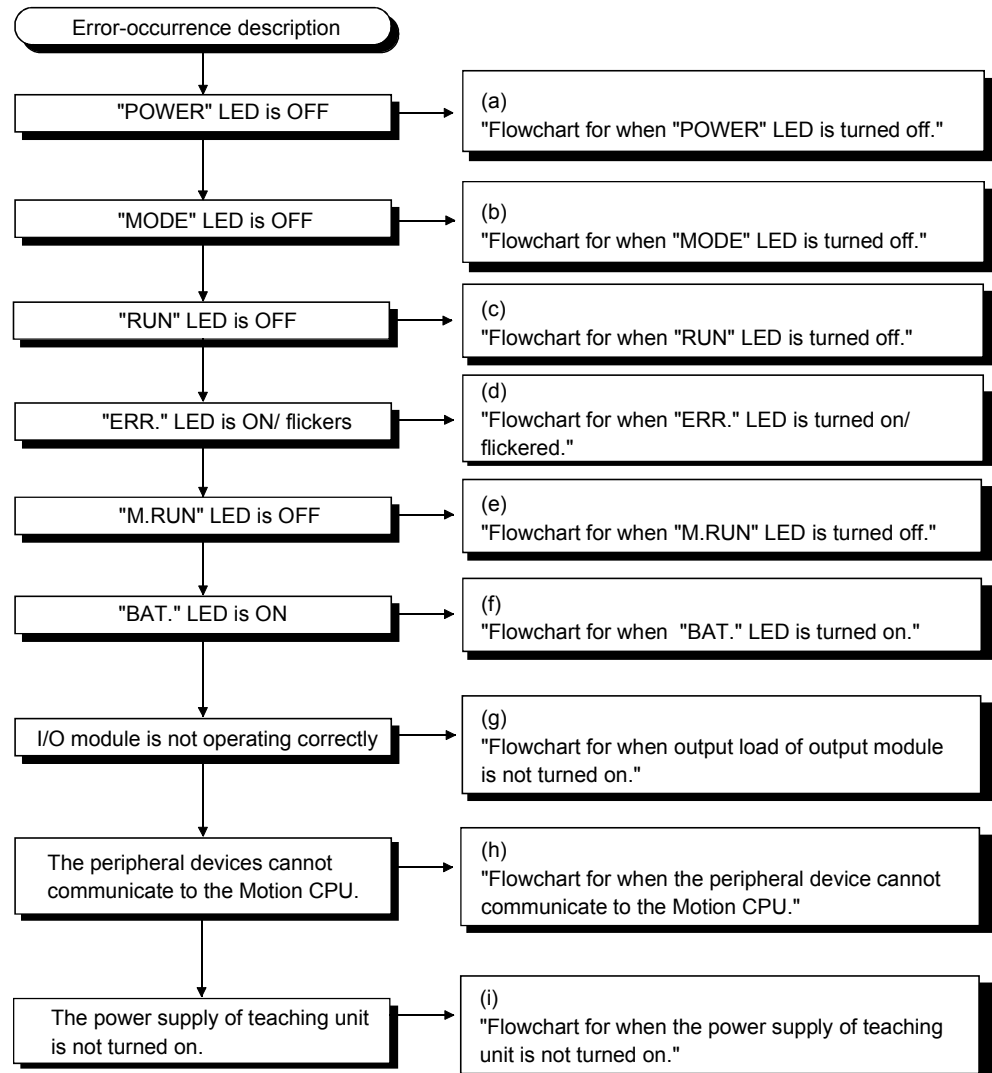

(a) Flowchart for when "POWER" LED is turned off.

The following shows the flowchart when the "POWER" LED is turned off at the power supply ON or during operation.

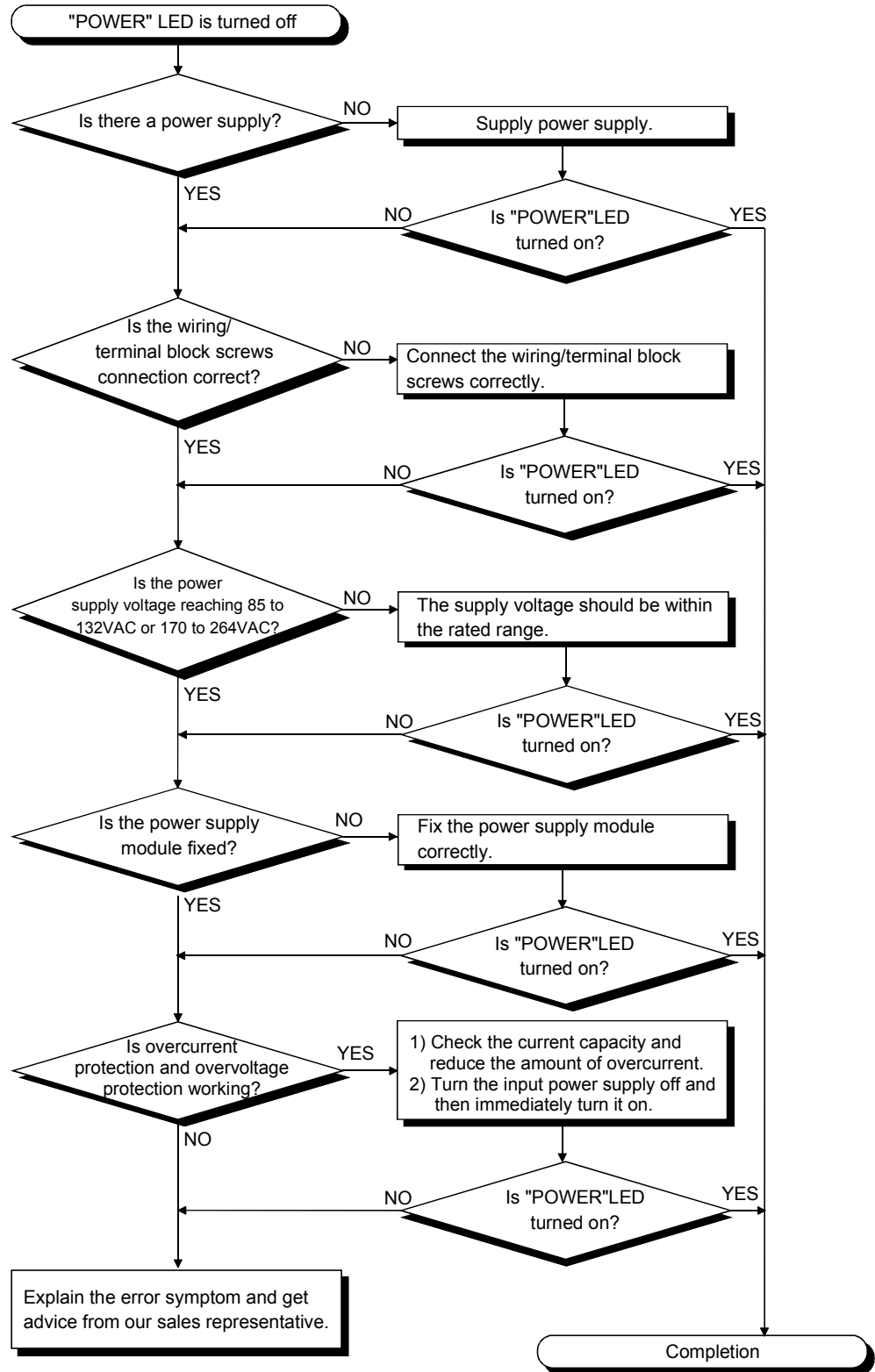

(b) Flowchart for when "MODE" LED is turned off.

The following shows the flowchart when the "MODE" LED is turned off at the power supply ON.

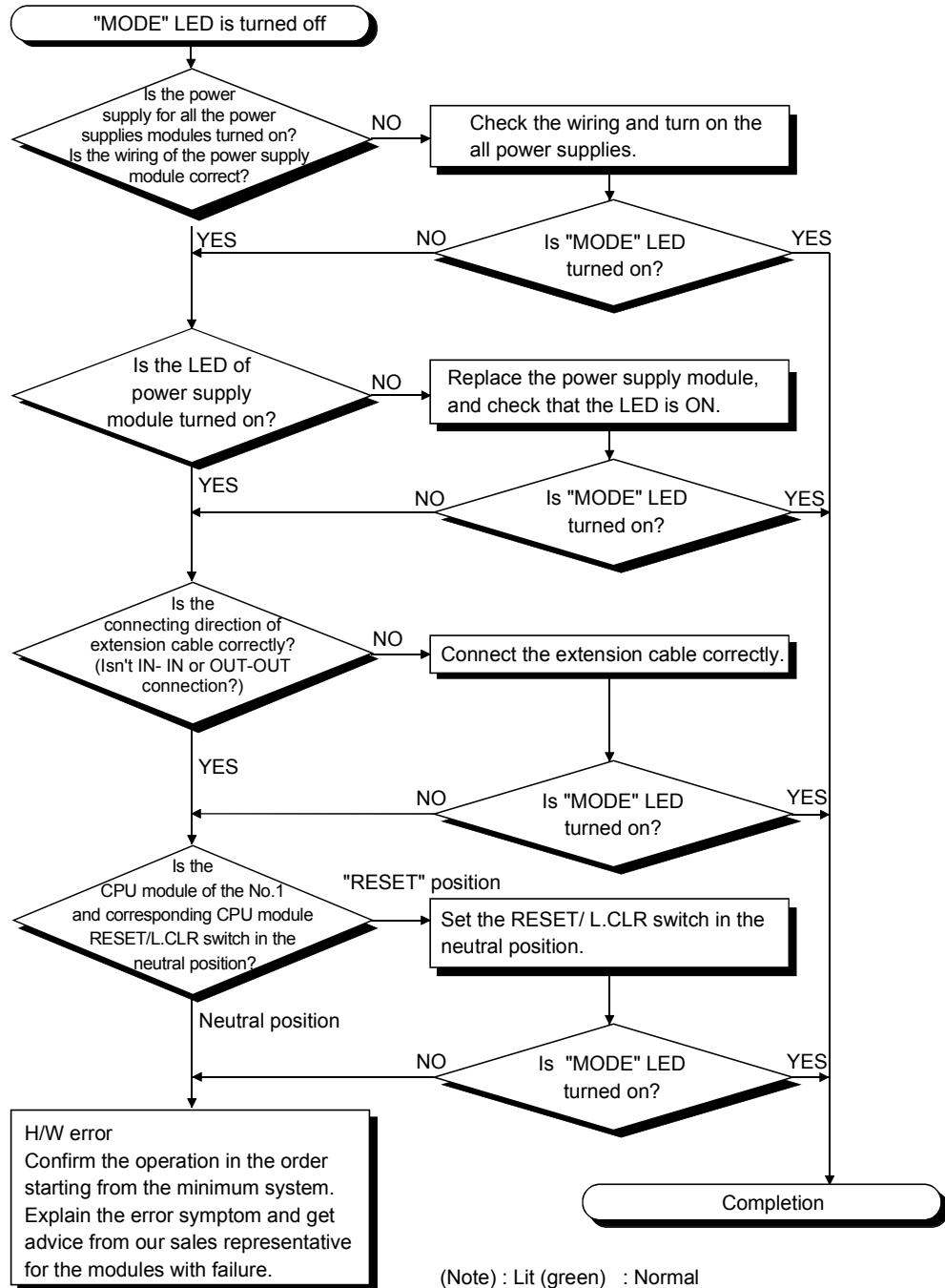

(c) Flowchart for when "RUN" LED is turned off.

The following shows the flowchart when the "RUN" LED is turned off during operation.

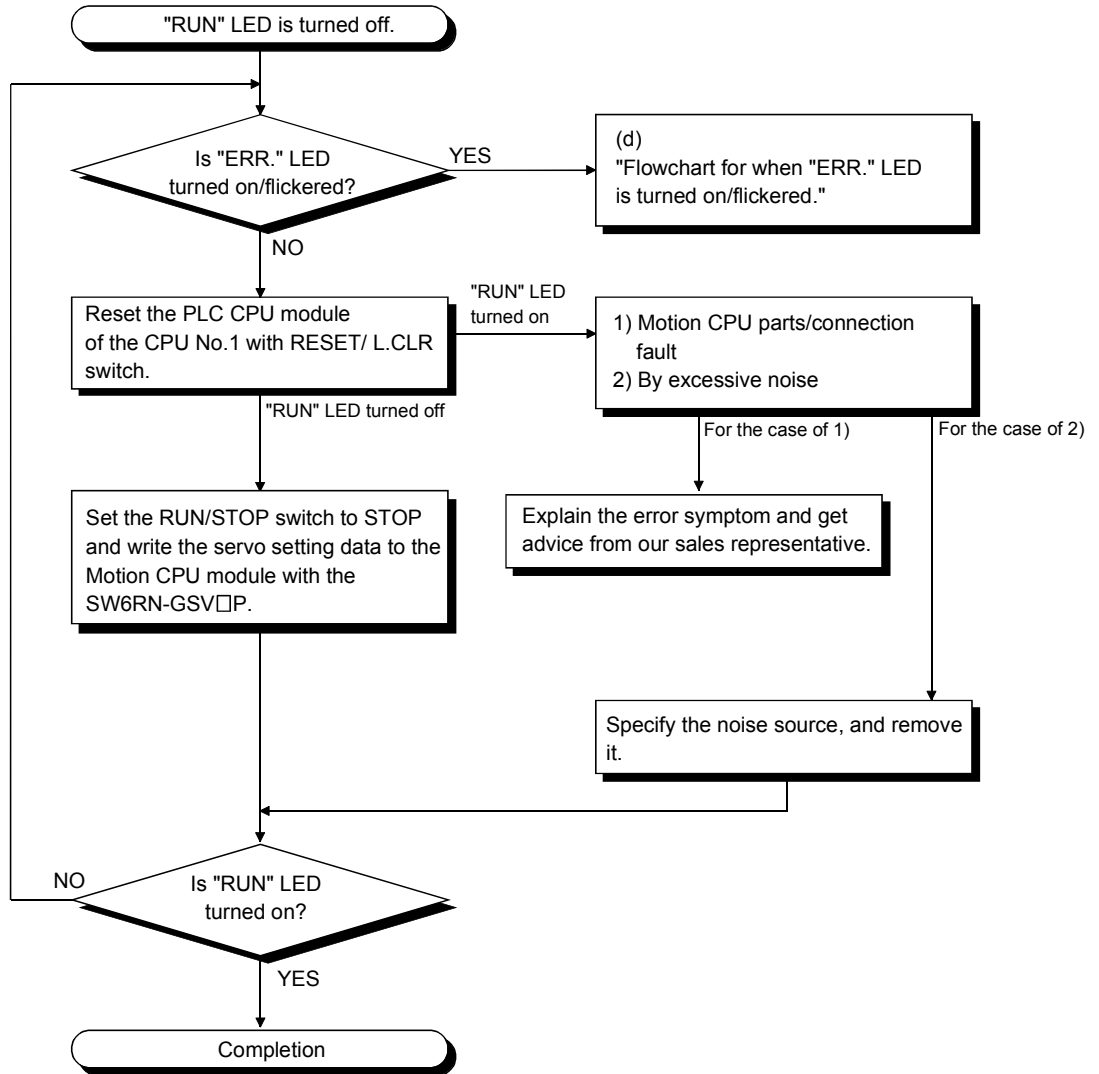

(d) Flowchart for when "ERR." LED is turned on/flickered.
 The following shows the flowchart to be followed when the "ERR." LED is turned on/flickered at the power supply ON or operation start or during operation.

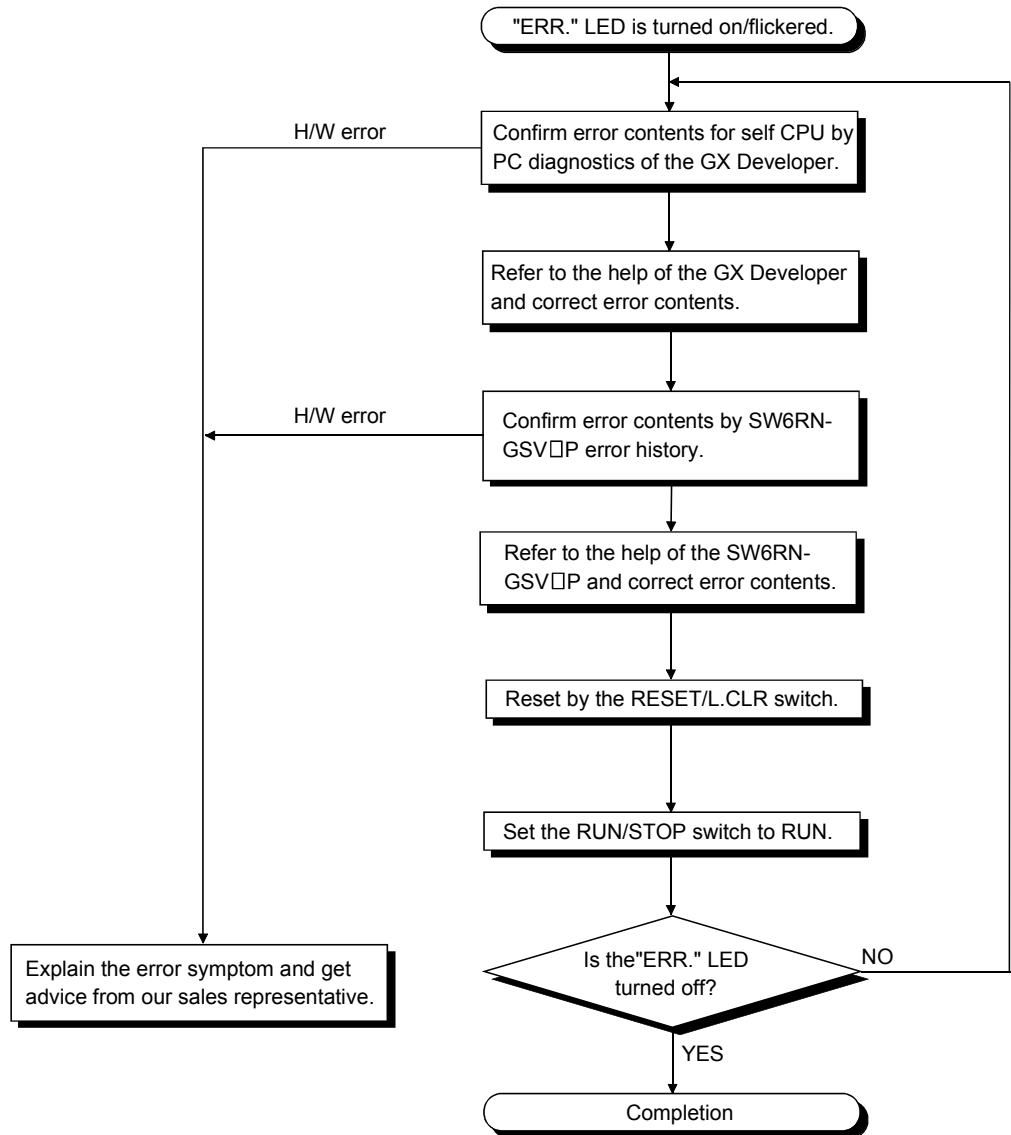

(e) Flowchart for when "M.RUN" LED is turned off.

The following shows the flowchart when the "M.RUN" LED is turned off during operation.

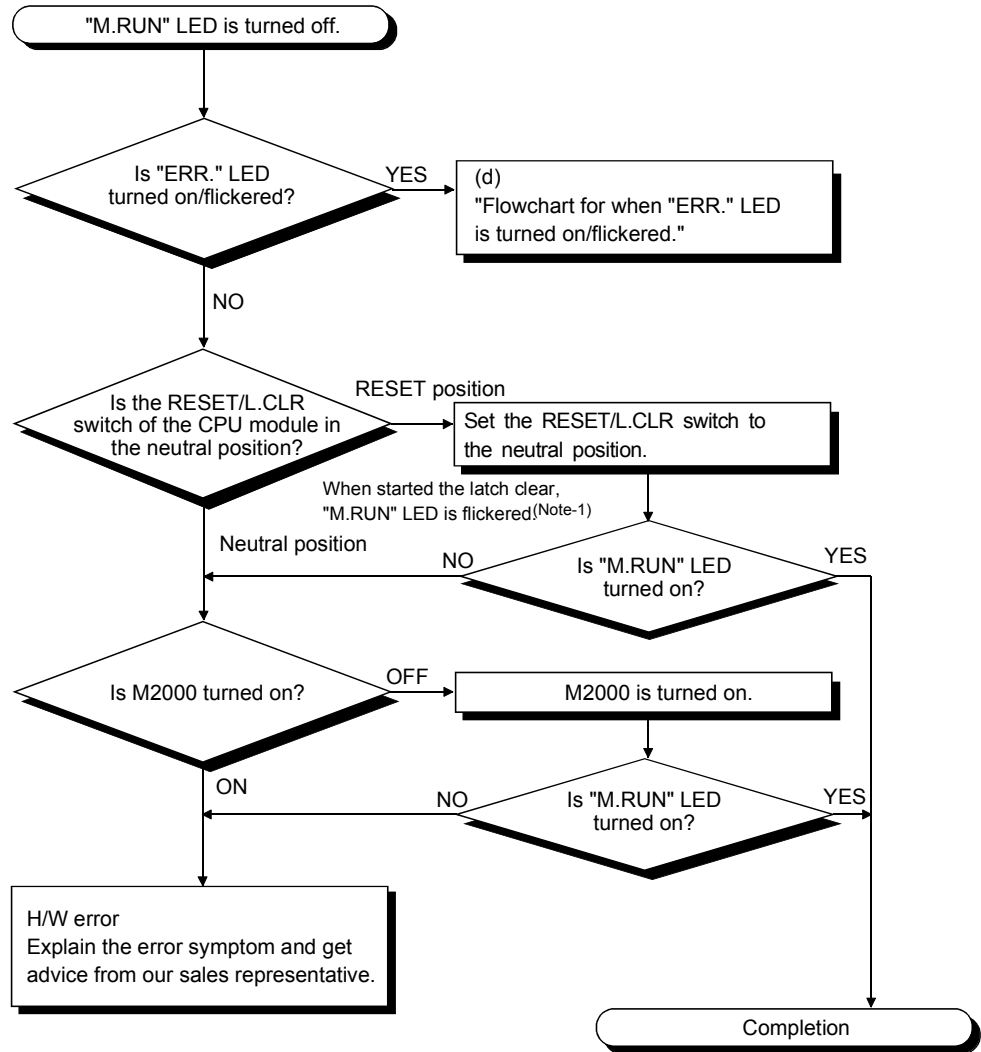

REMARK

(Note-1) : When the RUN/STOP switch is stop position and the RESET/L.CLR is tilted to L.CLR several times for latch clear operation, the "M.RUN" LED flashes to indicate that the latch clear processing is under operation. When the RESET/L.CLR switch is further tilted to L.CLR while the "M.RUN" LED flickers, "M.RUN" LED turned off and terminates the latch clear processing.

(f) Flowchart for when "BAT." LED is turned on.

In the Motion CPU, when the external battery capacity of the Battery holder unit is lowered, the LED is turned on.

After replacing the battery with a new one, "BAT." LED is turned off with the executing reset by the RESET/L.CLR switch.

When it is selected "used the external battery", though the external battery in the system settings is not used, the LED is also turned on.

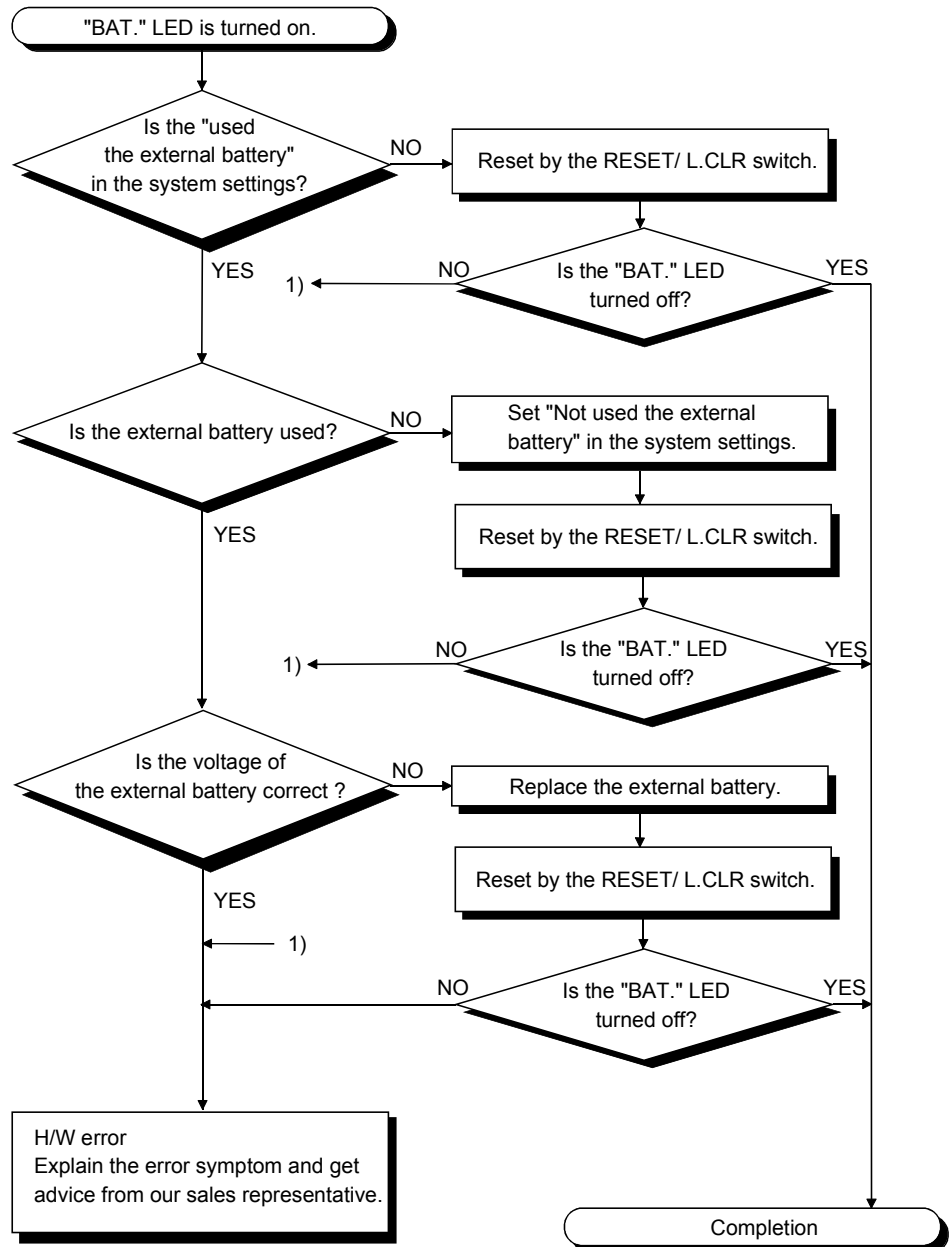

(g) Flowchart for when output load of output module is not turned on.

The following shows the flowchart when the output load of the output module is not turned on during operation.



POINT
 For information about input signal of the input module is not turned off, refer to section 6.6.3 I/O modules troubleshooting.

(h) Flowchart for when the peripheral device cannot communicate to the Motion controller.

The following shows the flowchart when the Motion CPU cannot communicate with the SW6RN-GSV□P during the power supply ON.

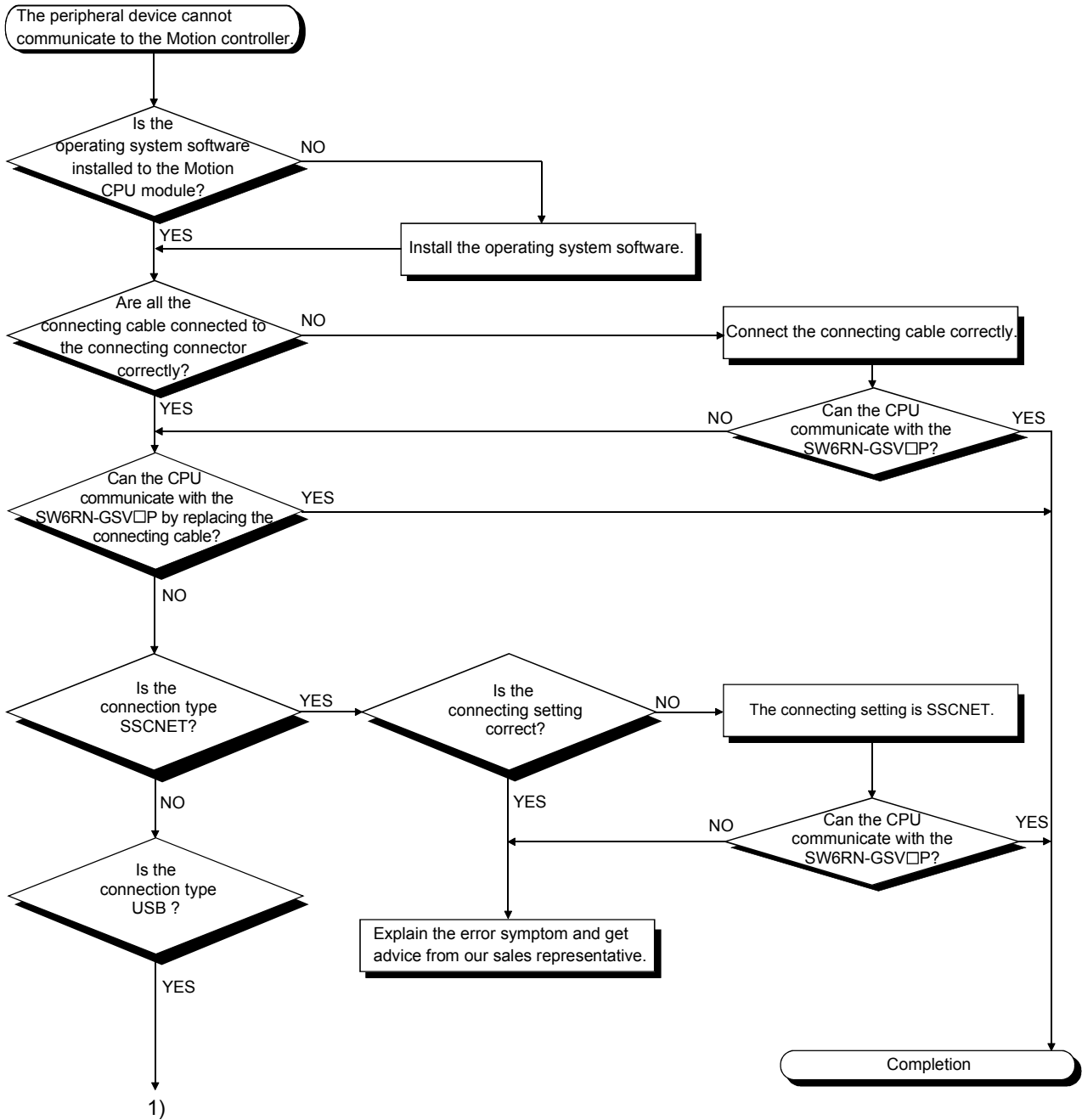

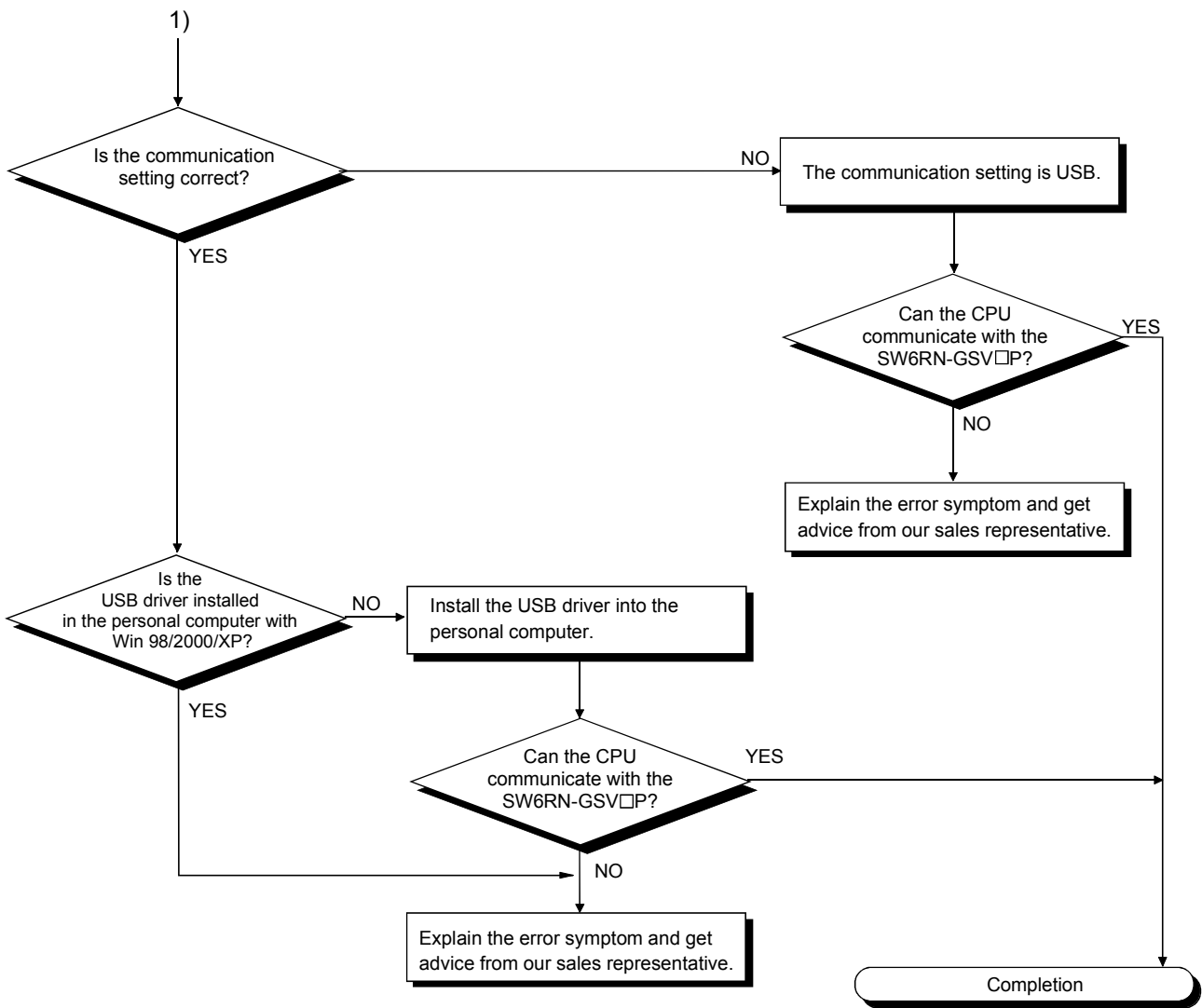

(i) Flowchart for when the power supply of teaching unit is not turned on.

The following shows the flowchart when the power supply of teaching unit is not turned on during the power supply of Motion CPU ON.

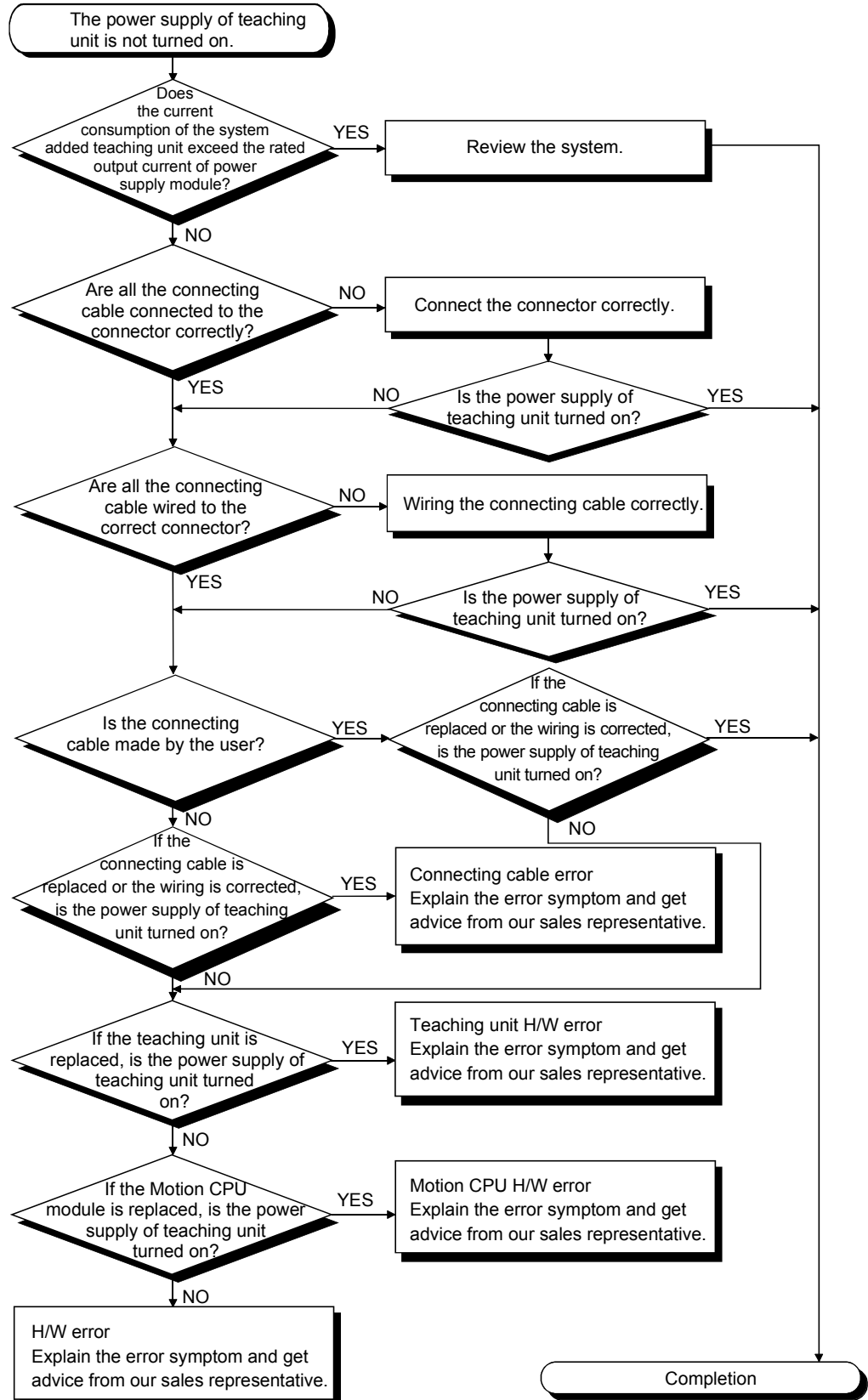

6.6.3 I/O modules troubleshooting

This section describes troubleshooting with I/O circuits and their corrective actions.

(1) Input circuit troubleshooting and corrective action

This section describes troubleshooting with input circuits and their corrective actions.

Input Circuit Troubleshooting and Corrective Action

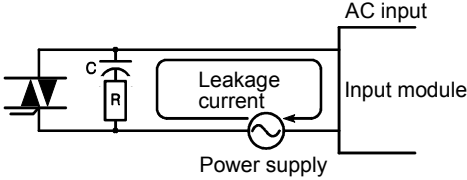
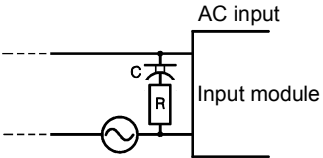
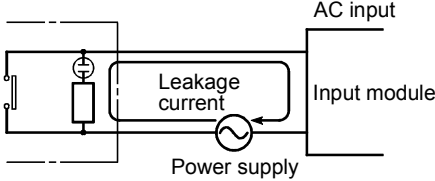
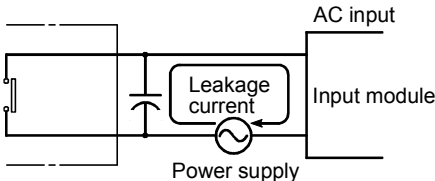
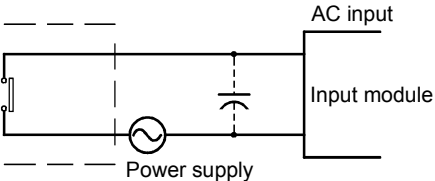
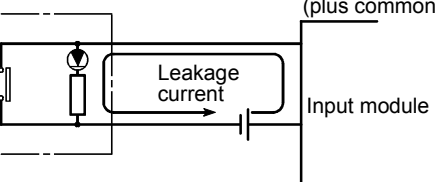
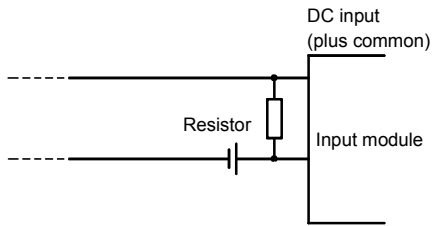
	Condition	Cause	Corrective action
Example 1	Input signal is not turned OFF.	<ul style="list-style-type: none"> Leakage current of input switch (e.g. drive by non-contact switch). 	<ul style="list-style-type: none"> Connect an appropriate resistor which will make the voltage across the terminals of the input module lower than the OFF voltage value.  <p>It is recommended to use 0.1 to 0.47 [μF] + 47 to 120 [Ω] (1/2W) for the CR constant.</p>
Example 2	Input signal is not turned OFF.	<ul style="list-style-type: none"> Drive by a limit switch with neon lamp. 	<ul style="list-style-type: none"> Same as Example 1. Or make up another independent display circuit.
Example 3	Input signal is not turned OFF.	<ul style="list-style-type: none"> Leakage current due to wiring capacity of wiring cable. (Wiring capacity C of twisted pair wire is approx. 100 PF/m). 	<ul style="list-style-type: none"> Same as Example 1. However, leakage current is not generated when the power supply is located in the input equipment side as shown below. 
Example 4	Input signal is not turned OFF.	<ul style="list-style-type: none"> Drive by switch with LED indicator. 	<ul style="list-style-type: none"> Connect a resistor which will make the voltage between the input module terminal and common higher than the OFF voltage value, as shown below.  <p>(Note-1) : A calculation example of a value for a connected resistor is given on the following page.</p>

Input Circuit Troubleshooting and Corrective Action (Continued)

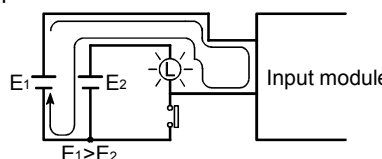
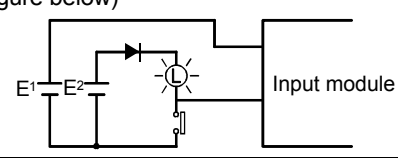
	Condition	Cause	Corrective action
Example 5	Input signal does not turn OFF.	<ul style="list-style-type: none"> Sneak path due to the use of two power supplies. 	<ul style="list-style-type: none"> Use only one power supply. Connect a sneak path prevention diode. (Figure below) 
Example 6	False input due to noise	Depending on short response time setting, noise is imported as input.	Change response time setting. Example : 10[ms] → 20[ms]

<Calculation example of Example 4>

For the case with a switch with LED indicator connected to Q172LX, causing 4 [mA] leakage current.

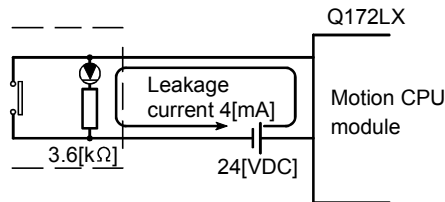

(a) The 0.18 [mA] OFF current of the Q172LX is not satisfied. Connect a resistor as shown below.

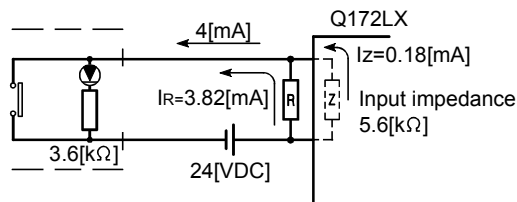

(b) Calculate the connecting resistor value R as indicated below.

To satisfy the 0.18 [mA] OFF current of the Q172LX, the resistor R to be connected may be the one where 3.82 [mA] or more will flow.

$I_R = I_Z = Z(\text{Input impedance}) : R$

$$R \leq \frac{I_Z}{I_R} \times Z(\text{Input impedance}) = \frac{0.18}{3.82} \times 5.6 \times 10^3 = 264 [\Omega]$$

$R < 264 [\Omega]$.

Assuming that resistor R is 220 [Ω], the power capacity W of resistor R is:

$$W = (\text{Input voltage})^2 \div R = 26.4^2 \div 220 = 3.168 [\text{W}]$$

(c) The power capacity of the resistor selected is 3 to 5 times greater than the actual current consumption. 220 [Ω], 10 to 15 [W] resistor may therefore be connected to the terminal in question.

(2) Output circuit troubleshooting and corrective action

This section describes troubleshooting with output circuits and their corrective actions.

Output Circuit Troubleshooting and Corrective Action

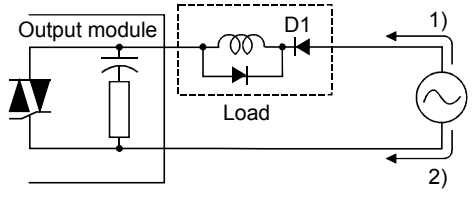
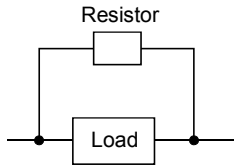
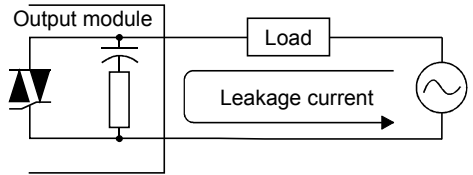
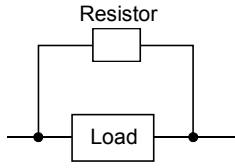
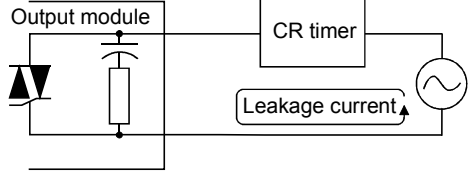
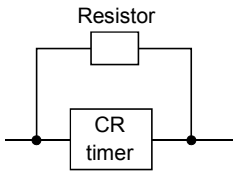
	Condition	Cause	Corrective action
Example 1	Overvoltage applied to load when output turns OFF	<ul style="list-style-type: none"> If load is internally half-wave rectified (some solenoids are like this).  <ul style="list-style-type: none"> With polarity of power supply 1), C is charged. With polarity 2), the C charge voltage plus the power supply voltage is applied across D1. Max. voltage is approx. 2.2E. 	<ul style="list-style-type: none"> Connect a resistor between several tens kΩ and several hundreds k across the load. <p>This method causes no problems with output terminals but lead to deterioration or burnout of load internal diodes.</p> 
Example 2	Load does not turn OFF (Triac output).	<ul style="list-style-type: none"> Leakage current due to built-in surge suppressor. 	<ul style="list-style-type: none"> Connect a resistor across the load. <p>If long wiring exists between the output card and the load, leakage currents also arise due to wiring capacity.</p> 
Example 3	Time period fluctuates when load is a CR timer (Triac output)		<ul style="list-style-type: none"> Drive a relay and use the contacts to drive the CR timer. <p>Be careful of example 1, as some timers are half-wave rectified internally.</p>  <p>Calculate resistor constant from load.</p>

6.7 Confirm method of Error Code

When an error occurs, the error code and error message can be read by the personal computer(IBM PC/AT) installation of the SW6RN-GSV□P.

The procedure for reading error codes by the SW6RN-GSV□P is as follows.

- (1) Start the SW6RN-GSV□P.
- (2) Connect the Motion CPU to the personal computer(IBM PC/AT) .
- (3) Select [Create a new project] - [Motion CPU Read] Menu by the SW6RN-GSV□P, and also read the project data from the Motion CPU.
- (4) Select the [Monitor] - [PV Enlarged Monitor] Menu.
- (5) Confirm the error code and error message that is displayed on the screen.

For details of the SW6RN-GSV□P operating method, refer to help of each programming software package.

APPENDICES

APPENDIX 1 Cables

In this cable connection diagram, maker names of connectors are omitted. Refer to "APPENDIX 2.7 Connector" for maker names of connectors.

APPENDIX 1.1 SSCNET III cables

Generally use the SSCNET III cables available as our options.

(1) Model explanation

Numeral in the column of cable length on the table is a symbol put in the "□" part of cable model. Cables of which symbol exists are available.

Cable model	Cable length [m(ft.)]											Flex life	Application/remark
	0.15 (0.49)	0.3 (0.98)	0.5 (1.64)	1 (3.28)	3 (9.84)	5 (16.40)	10 (32.81)	20 (65.62)	30 (98.43)	40 (131.23)	50 (164.04)		
MR-J3BUS□M	015	03	05	1	3	/	/	/	/	/	/	Standard	Standard code for inside panel
MR-J3BUS□M-A	/	/	/	/	/	5	10	20	/	/	/	Standard	Standard cable for outside panel
MR-J3BUS□M-B (Note-1)	/	/	/	/	/	/	/	/	30	40	50	Long flex	Long distance cable

(Note-1) : For the cable of less than 30[m](98.43[ft.]), contact your nearest Mitsubishi sales representative.

(2) Specifications

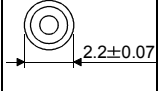
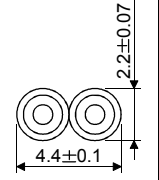
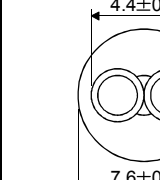
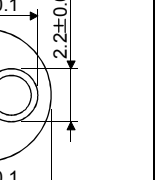
		Description			
SSCNET III cable model		MR-J3BUS□M		MR-J3BUS□M-A	MR-J3BUS□M-B
SSCNET III cable length [m(ft.)]		0.15 (0.49)	0.3 to 3 (0.98 to 9.84)	5 to 20 (16.40 to 65.62)	30 to 50 (98.43 to 164.04)
Optical cable (Code)	Minimum bend radius [mm(inch)]	25(0.98)		Reinforcing coat cable: 50 (1.97) Code: 25 (0.98)	Reinforcing coat cable: 50 (1.97) Code : 30(1.18)
	Tension strength [N]	70	140	420 (Enforced covering cord)	980 (Enforced covering cord)
	Temperature range for use [°C(°F)] (Note-1)	-40 to 80 (-40 to 176)			-20 to 70 (-4 to 158)
	Ambient	Indoors (no direct sunlight), No solvent or oil			
External appearance [mm]					

(Note-1): This temperature range for use is the value for optical cable (cord) only.

App.

POINTS
<p>(1) If the end face of code tip for the SSCNETⅢ cable is dirty, optical transmission is interrupted and it may cause malfunctions. If it becomes dirty, wipe with a bonded textile, etc. Do not use solvent such as alcohol.</p> <p>(2) If the end face of code tip for SSCNETⅢ cable is dirty, optical transmission is interrupted and it may cause malfunctions. If it becomes dirty, wipe with a bonded textile, etc. Do not use solvent such as alcohol.</p> <p>(3) When incinerating the SSCNETⅢ cable (optical fiber), hydrogen fluoride gas or hydrogen chloride gas which is corrosive and harmful may be generated. For disposal of the SSCNETⅢ cable (optical fiber), request for specialized industrial waste disposal services who has incineration facility for disposing hydrogen fluoride gas or hydrogen chloride gas.</p>

(a) MR-J3BUS□M

1) Model explanation

Type: MR-J3BUS□M-*

Symbol	Cable type
None	Standard code for inside panel
A	Standard cable for outside panel
B	Long distance cable

Symbol	Cable length [m(ft.)]
015	0.15(0.49)
03	0.3(0.98)
05	0.5(1.64)
1	1(3.28)
3	3(9.84)
5	5(16.40)
10	10(32.81)
20	20(65.62)
30	30(98.43)
40	40(131.23)
50	50(164.04)

2) Exterior dimensions

• MR-J3BUS015M

[Unit: mm(inch)]

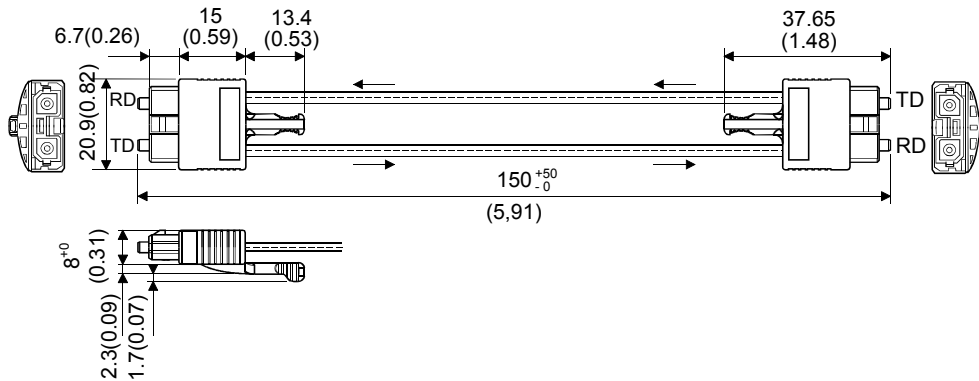

• MR-J3BUS03M to MR-J3BUS3M

[Unit: mm(inch)]

Refer to the table of this section (1) for cable length (L).

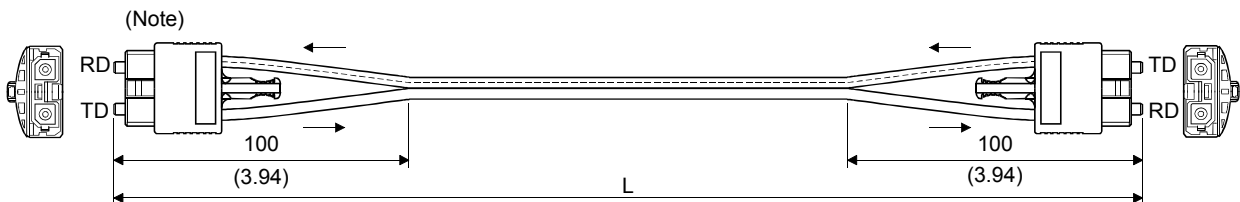

(Note) : Dimension of connector part is the same as that of MR-J3BUS015M.

APPENDICES

- MR-J3BUS5M-A to MR-J3BUS20M-A, MR-J3BUS30M-B to MR-J3BUS50M-B

Refer to the table of this section (1) for cable length (L).

SSCNET III cable	Variation [mm(inch)]	
	A	B
MR-J3BUS5M-A to MR-J3BUS20M-A	100(3.94)	30(1.18)
MR-J3BUS30M-B to MR-J3BUS50M-B	150(5.91)	50(1.97)

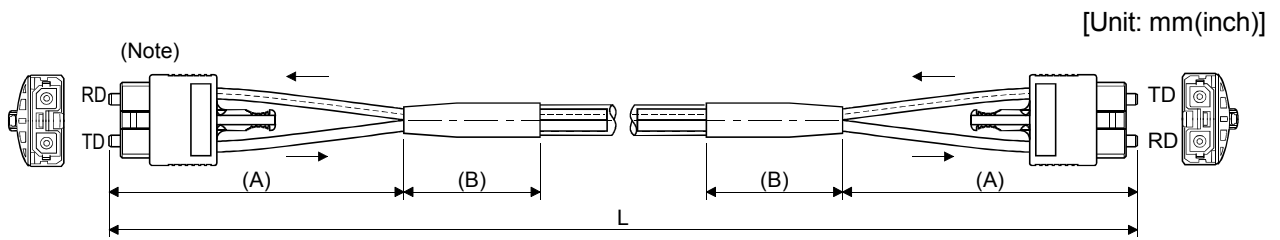

(Note) : Dimension of connector part is the same as that of MR-J3BUS015M.

APPENDIX 1.2 Serial absolute synchronous encoder cable

Generally use the serial absolute synchronous encoder cables available as our options. If the required length is not found in our options, fabricate the cable on the customer side.

(1) Selection

The following table indicates the serial absolute synchronous encoder cables used with the serial absolute synchronous encoder.

Connector sets (Q170ENCCNS) are also available for your fabrication.

Table 1 Wire models

Type	Length [m(ft.)]	Wire model
Q170ENCCBL□M	2(6.56), 5(16.40), 10(32.81), 20(65.62), 30(98.43), 50(164.04)	M14B0023 12 pair (BLACK)

Use the following or equivalent twisted pair cables as the serial absolute synchronous encoder cables.

Table 2 Connector sets

Connector sets type	Description
Q170ENCCNS	<ul style="list-style-type: none"> • Connector shell kits • Plug cable clump

Table 3 Wire specifications

Wire model	Core size [mm ²]	Number of cores	Characteristics of one core			Finished OD [mm] (Note-2)
			Structure [Number of wires/mm]	Conductor resistance [Ω/km]	Insulating sheath OD d[mm] (Note-1)	
M14B0023 12 pair (BLACK)	0.2	24(12 pair)	40/0.08	105 or less	0.88	11.0

(Note-1): "d" is as shown below.

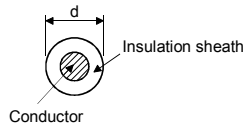

(Note-2): Standard OD (Outside Diameter). Maximum OD is about 10% larger.

⚠ CAUTION
<p>● When fabricating the encoder cable, do not make incorrect connection. Wrong connection will cause runaway or explosion.</p>

(2) Q170ENCCBL□M
 (a) Model explanation

Type: Q170ENCCBL□M

Symbol	Cable length [m(ft.)]
2	2(6.56)
5	5(16.40)
10	10(32.81)
20	20(65.62)
30	30(98.43)
50	50(164.04)

(b) Connection diagram

When fabricating a cable, use the recommended wire and connector set Q170ENCCNS for encoder cable given on APPENDIX 1.2, and make the cable as show in the following connection diagram. Maximum cable length is 50m(164.04ft.).

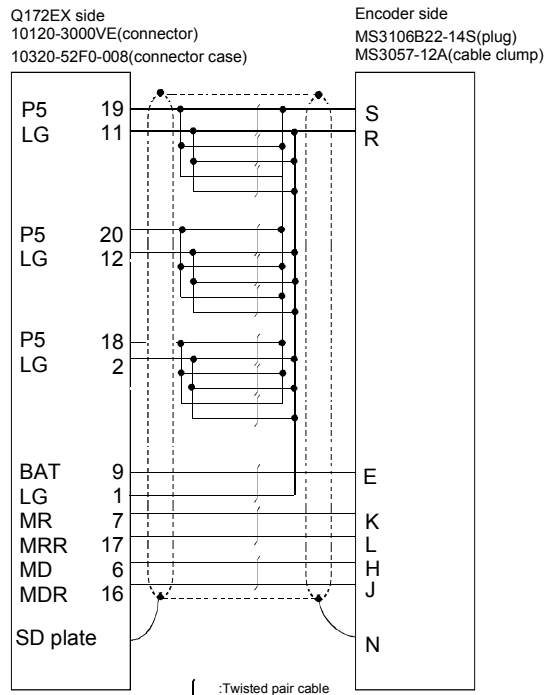
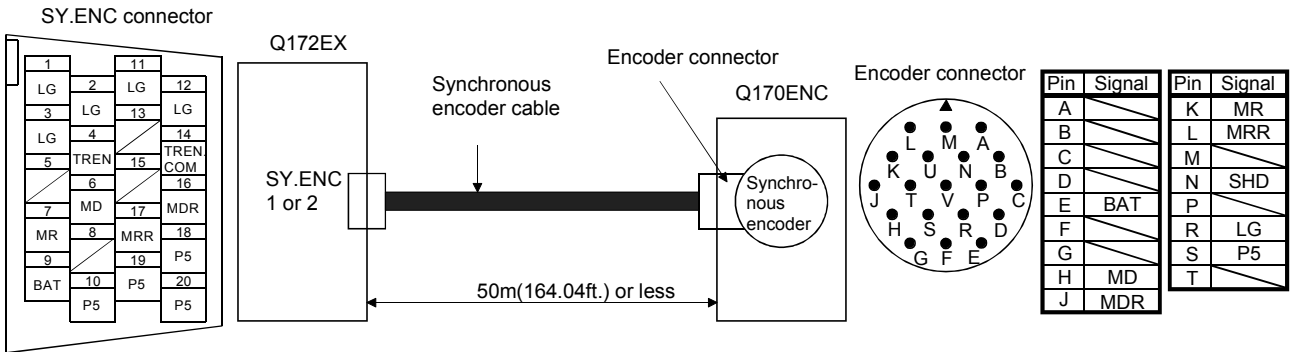

Cable length 50m(164.04ft.) or less

APPENDIX 1.3 Cable for the teaching unit

Generally use the cables for the teaching unit available as our options. If the required length is not found in our options, fabricate the cable on the customer side.

(1) Selection

The following table indicates the cables used with the cable for the teaching unit. Make selection according to your operating conditions.

Table 4 Wire models

Type	Length [m(ft.)]	Wire model
Q170TUD3CBL3M	3(9.84)	UL20276 AWG#28 13pair(CREAM)
Q170TUDNCBL3M		
Q170TUDNCBL03M-A	0.3(0.98)	
A31TU-D□ extended cable	— (Note)	UL20276 AWG#24 18pair(CREAM)

(Note) : The cable overall distance between the Motion CPU and teaching unit is within 30m(98.43ft.) include the A31TU-D□ cable (5m(16.40ft.)).

Use the following cables or equivalent twisted pair cables as the cables for the teaching unit.

Table 5 Connector models

Cable models for the teaching unit	Description
Q170TUD3CBL3M/ Q170TUDNCBL3M	<ul style="list-style-type: none"> • TU connector side <ul style="list-style-type: none"> HDR-E26FG1 : Connector HDR-E26-LPA5 : Connector case • Teaching unit side <ul style="list-style-type: none"> DB-25SF-N : Connector D20418-J3 : Screw lock DB20962 : Circular clamp
Q170TUDNCBL03M-A	<ul style="list-style-type: none"> • TU connector side <ul style="list-style-type: none"> HDR-E26FG1 : Connector HDR-E26-LPA5 : Connector case • Teaching unit side <ul style="list-style-type: none"> 17JE-13250-02(D8A) : Connector 17L-002A : Stud
A31TU-D□ extended cable	<ul style="list-style-type: none"> • Q170TUD□CBL□M(-A) side <ul style="list-style-type: none"> 17JE-23250-02(D8A) : Connector • Teaching unit side <ul style="list-style-type: none"> 17JE-13250-02(D8A) : Connector 17L-002A : Stud

Table 6 Wire specifications

Wire model	Core size [mm ²]	Number of cores	Characteristics of one core			Finished OD [mm] (Note-2)
			Structure [Number of wires/mm]	Conductor resistance [Ω/km]	Insulating sheath OD d[mm] (Note-1)	
UL20276 AWG#28 13pair(CREAM)	0.08	26(13 pairs)	7/0.127	222 or less	0.38	6.5
UL20276 AWG#24 18pair(CREAM)	0.08	36(18 pairs)	7/0.203	92.3 or less	0.85	15.5

(Note-1): "d" is as shown below.

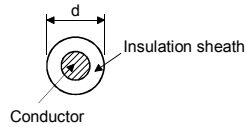

(Note-2): Standard OD (Outside Diameter). Maximum OD is about 10% larger.

⚠ CAUTION

- When fabricating the cable for teaching unit, do not make incorrect connection. The protective function stops working.

(2) Q170TUD3CBL3M

(a) Connection diagram

When fabricating a cable, use the recommended wire and connector given on APPENDIX 1.3, and make the cable as show in the following connection diagram. Make the cable within 3m(9.84ft.).

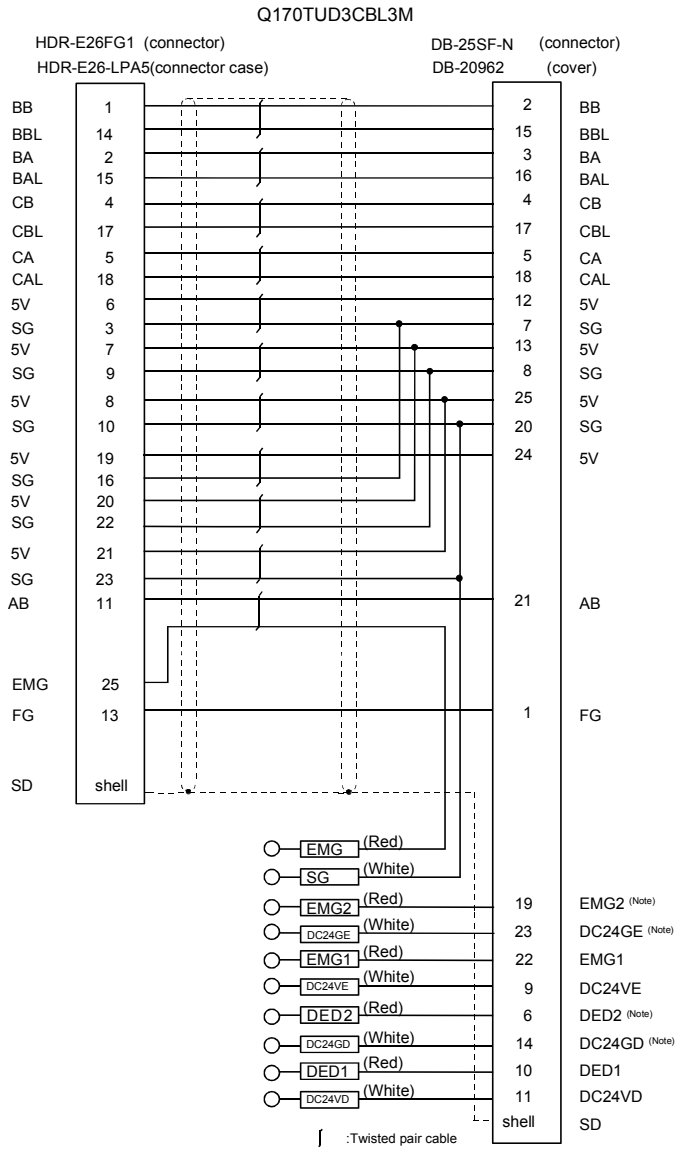

(Note) : These terminals are used to construct a double circuit by external safety circuit.
 Not connected by the cable Q170TUD3CBL3M when purchased.
 Please contact your nearest Mitsubishi sales representative for a double circuit.

(3) Q170TUDNCBL3M

(a) Connection diagram

When fabricating a cable, use the recommended wire and connector given on APPENDIX 1.3, and make the cable as show in the following connection diagram. Make the cable within 3m(9.84ft.).

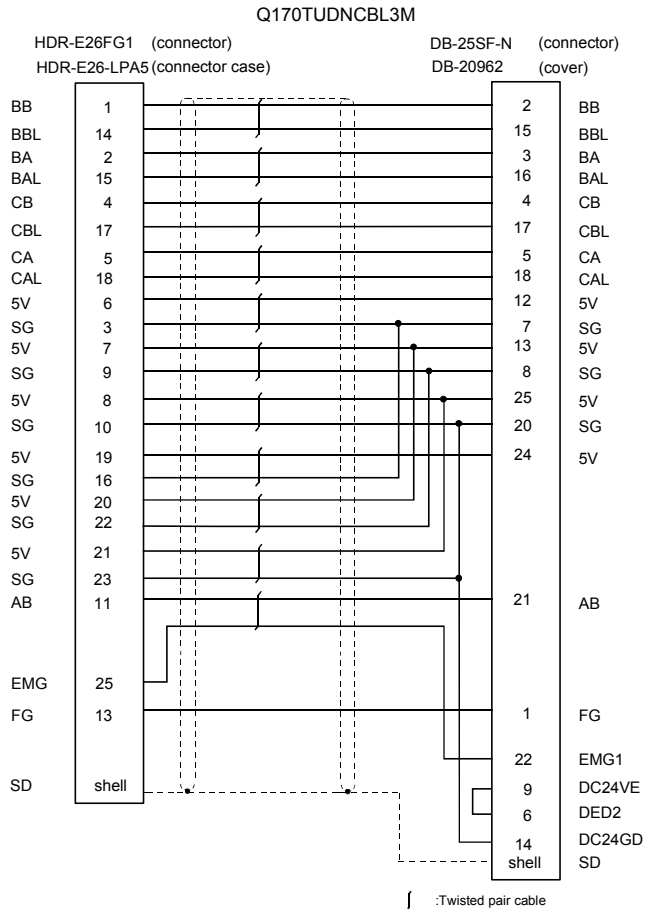

(4) Q170TUDNCBL03M-A

(a) Connection diagram

When fabricating a cable, use the recommended wire and connector given on APPENDIX 1.3, and make the cable as show in the following connection diagram. Make the cable within 3m(9.84ft.).

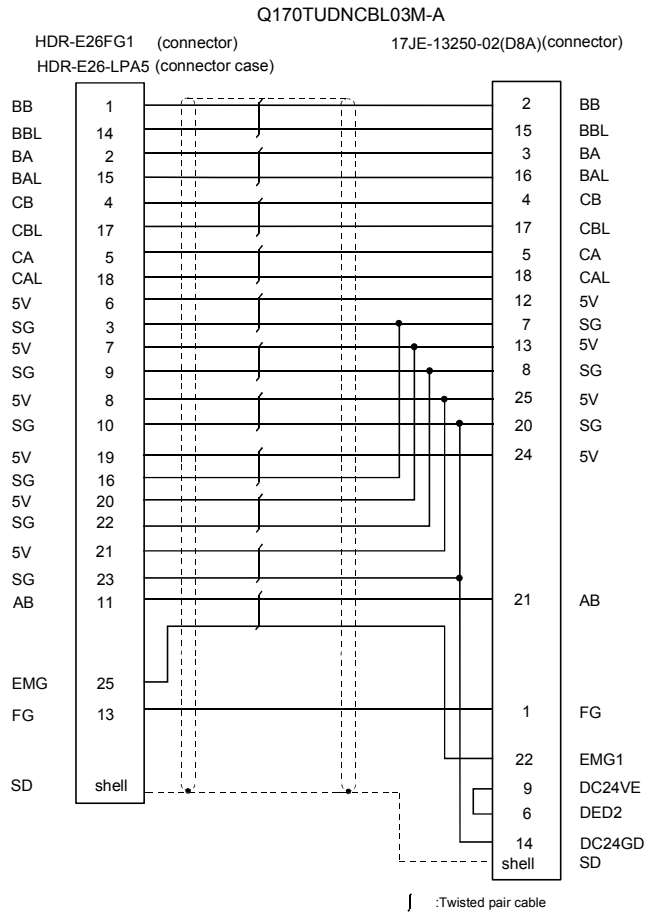

(5) A31TU-D□ extended cable

(a) Connection diagram

When fabricating a cable, use the recommended wire and connector given on APPENDIX 1.3, and make the cable as show in the following connection diagram. The cable overall distance between the Motion CPU and teaching unit is within 30m (98.43ft.) include the A31TU-D□ cable (5m(16.40ft.)). (Make the cable within 22m(72.18ft.) when using Q170TUD□CBL3M.)

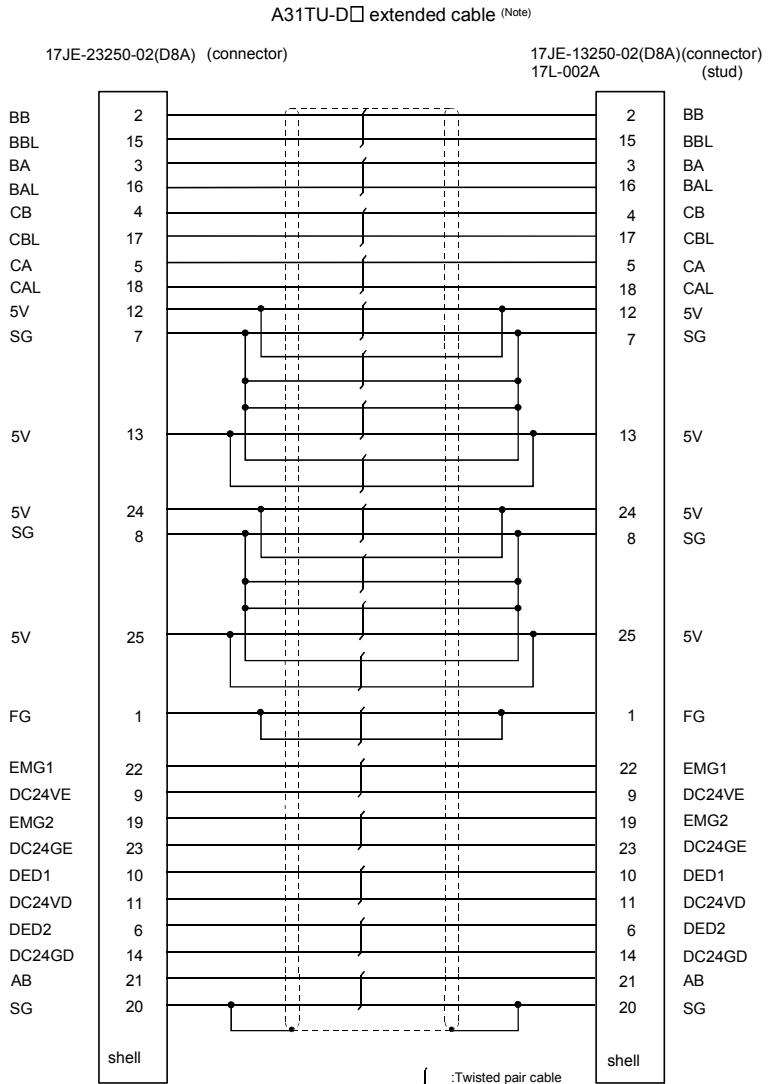

(Note) : Use a cable of wire size AWG24.

APPENDIX 1.4 Battery cable

Generally use the battery cable available as our options. If the required length is not found in our options, fabricate the cable on the customer side. Make the battery cable within 0.5m(1.64ft.).

(1) Hirose Electric make (DF3 model)

Number of pin	Model name	
	Terminal	Connector
3	DF3-2428-SCC	DF3-2S-2C

(2) Connection diagram

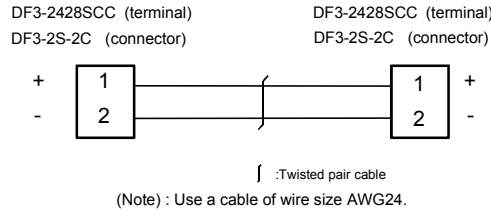

APPENDIX 2 Exterior Dimensions

APPENDIX 2.1 CPU module

(1) Q172HCPU Module

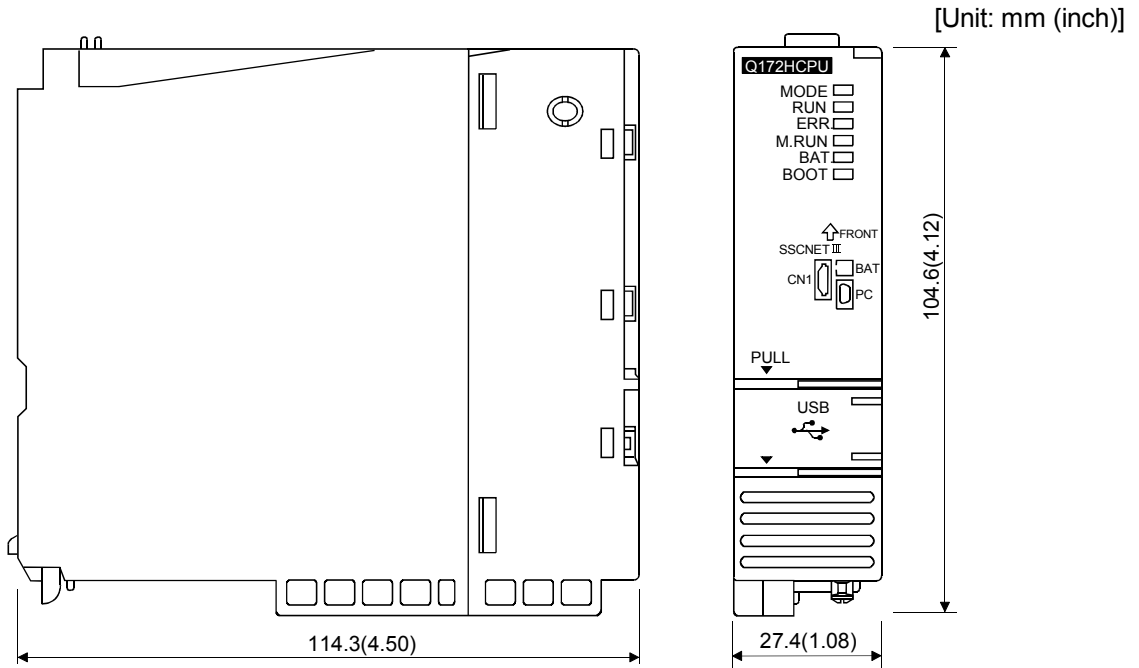

(2) Q173HCPU Module

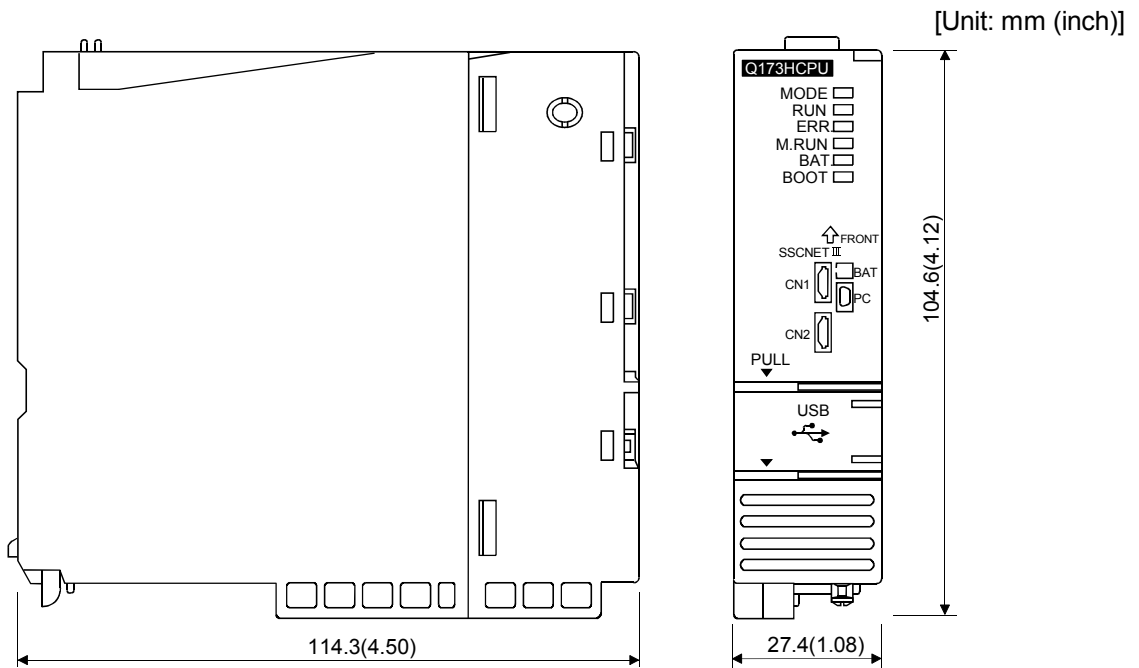

(3) Q172HCPU-T Module

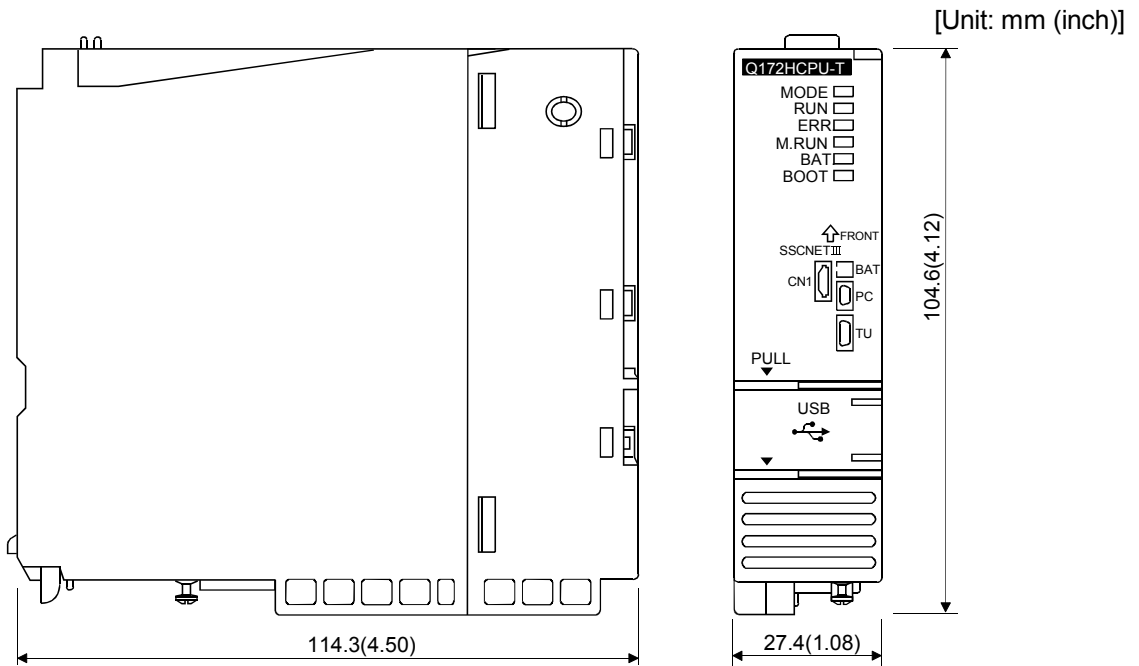

(4) Q173HCPU-T Module

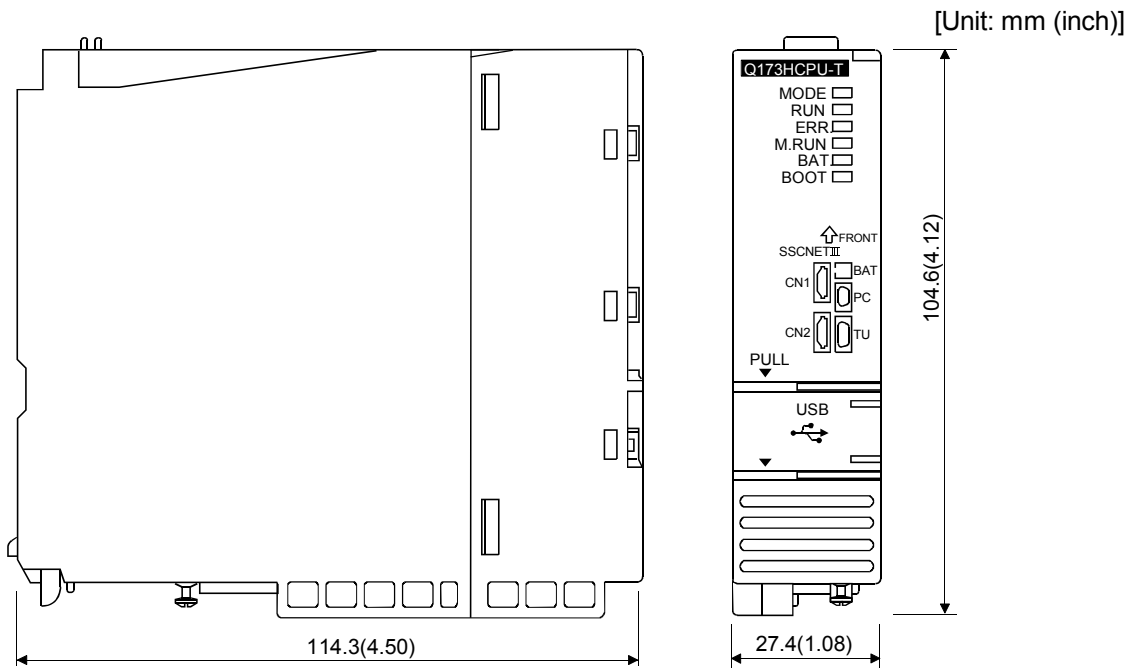

(5) Q173HCPU(-T)/Q172HCPU(-T) Module (with cable)

[Unit: mm (inch)]

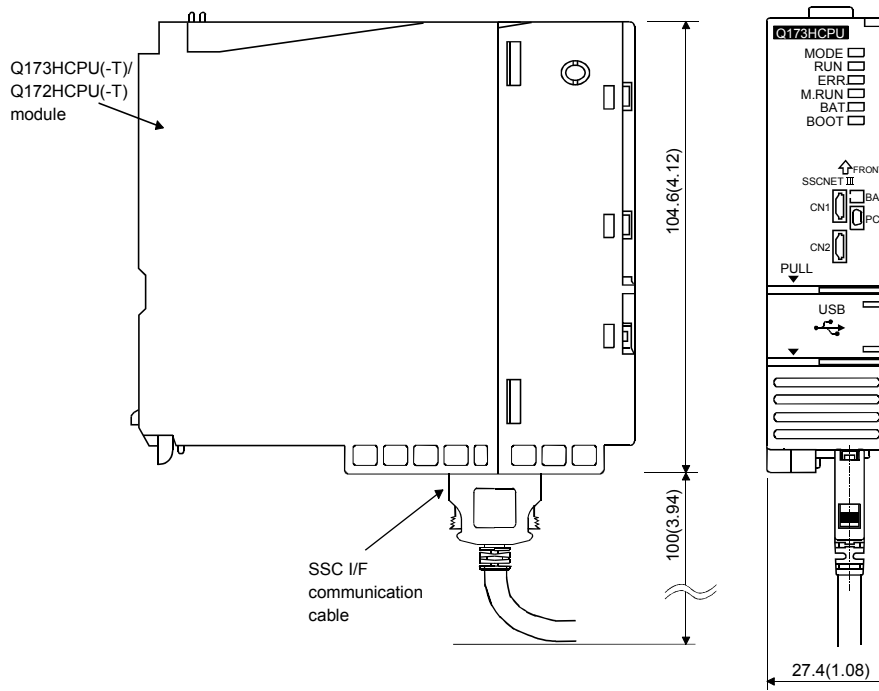

APPENDIX 2.2 Servo external signals interface module (Q172LX)

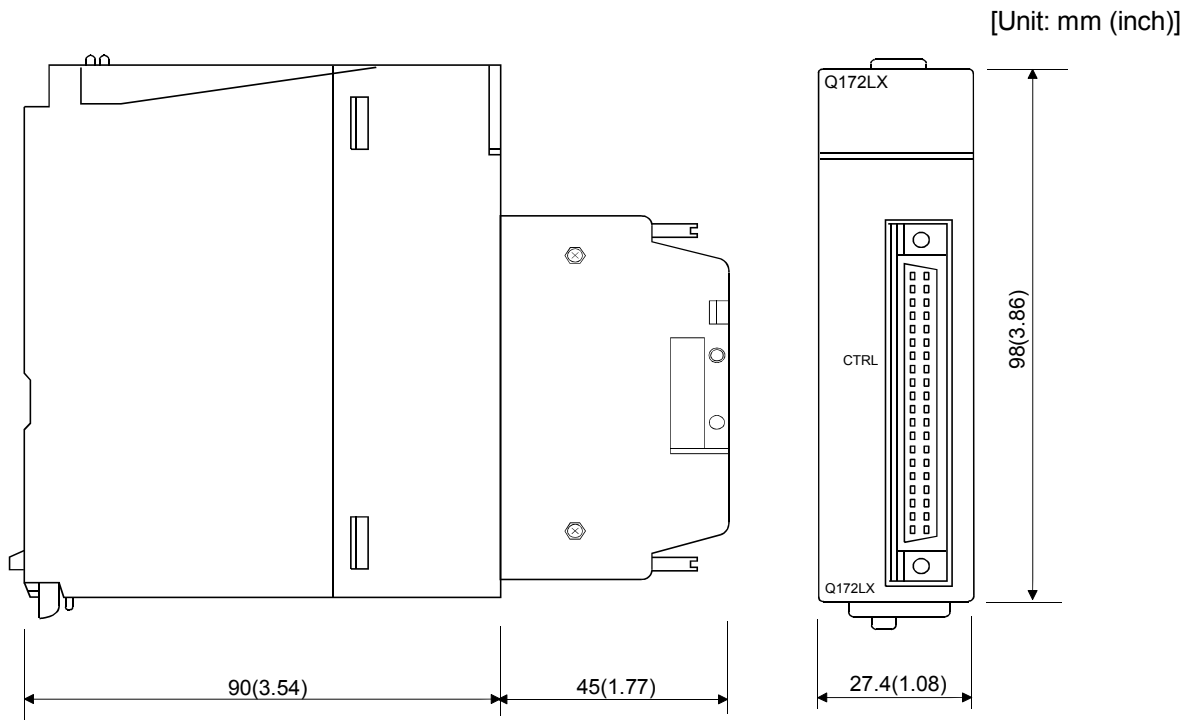

APPENDIX 2.3 Serial absolute synchronous encoder interface module (Q172EX-S2/Q172EX-S3)

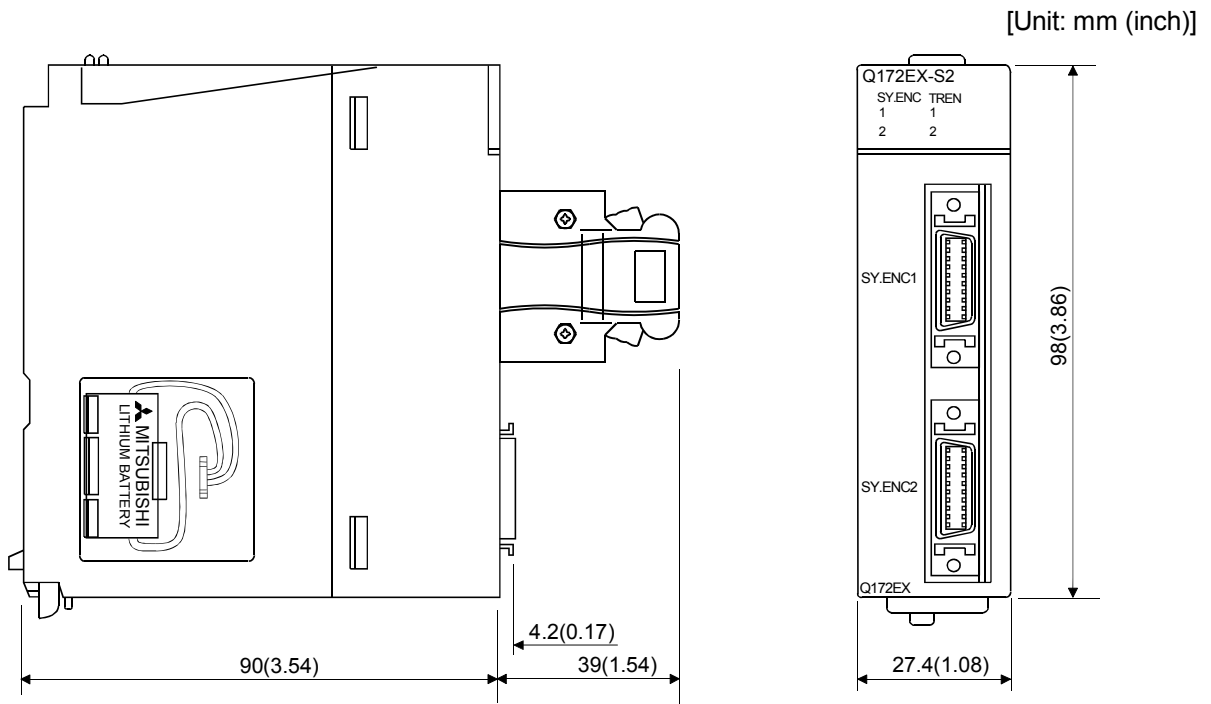

APPENDIX 2.4 Manual pulse generator interface module (Q173PX/Q173PX-S1)

(1) Q173PX

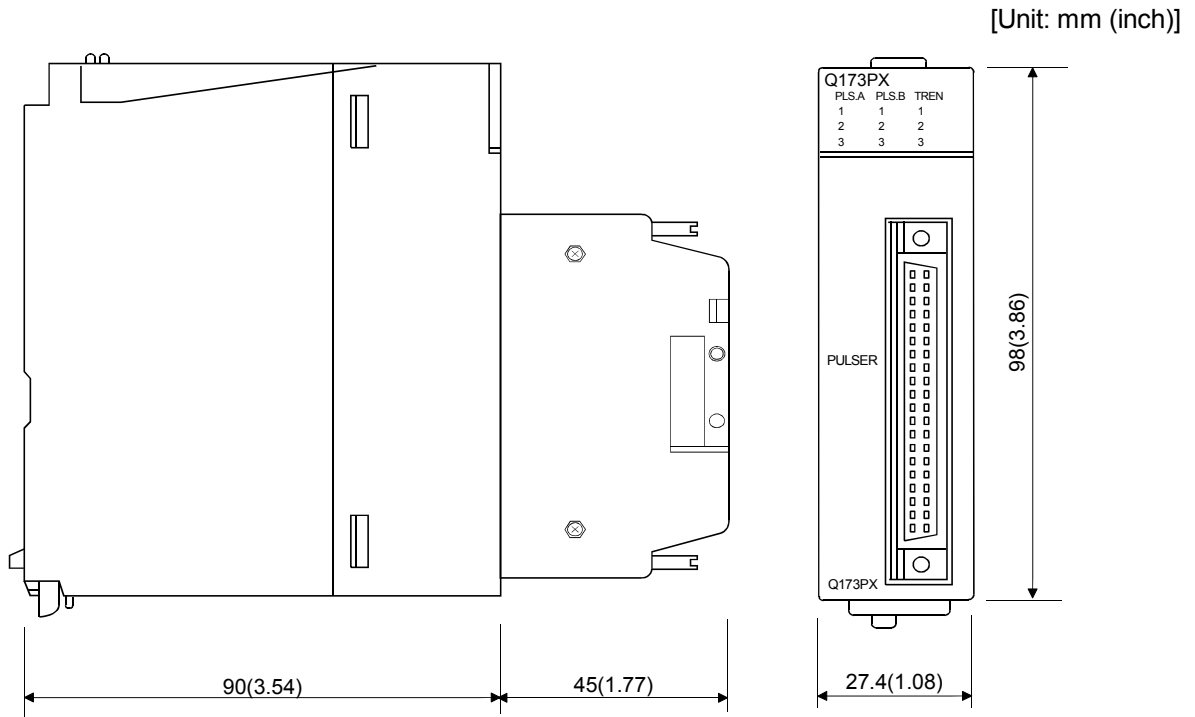

(2) Q173PX-S1

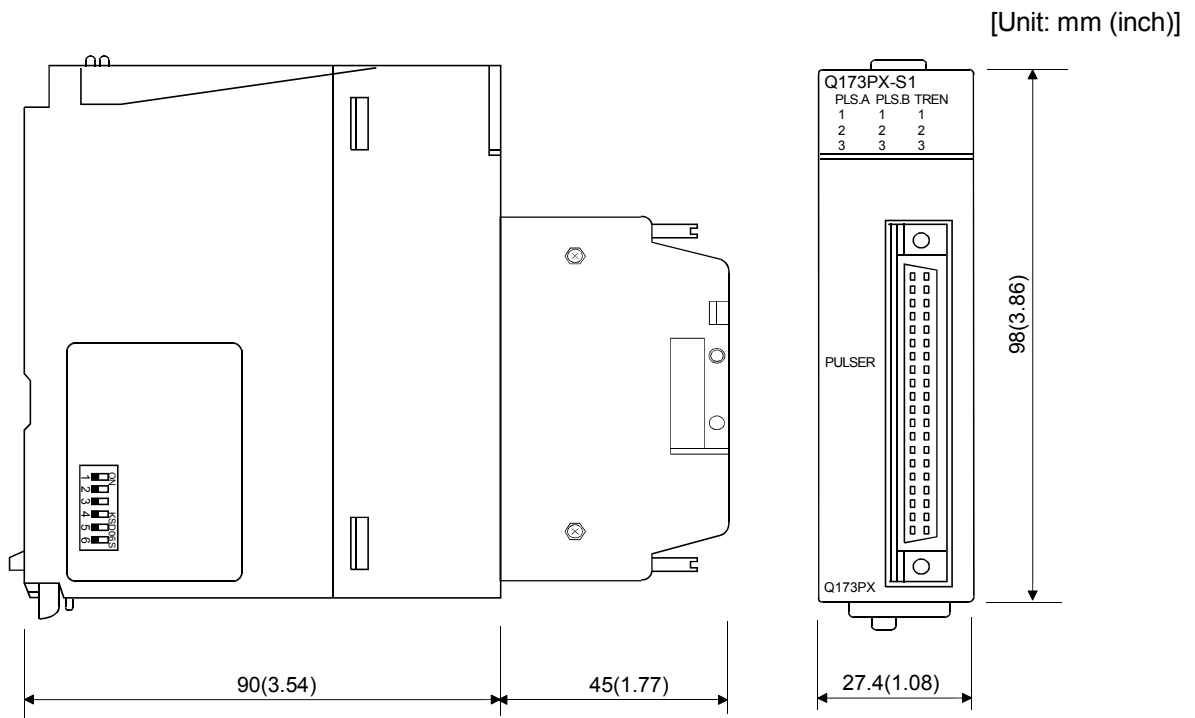

APPENDIX 2.5 Power supply module (Q61P-A1, Q61P-A2, Q61P, Q62P, Q63P, Q64P)

[Unit: mm (inch)]

(1) Q61P-A1, Q61P-A2, Q61P, Q62P, Q63P

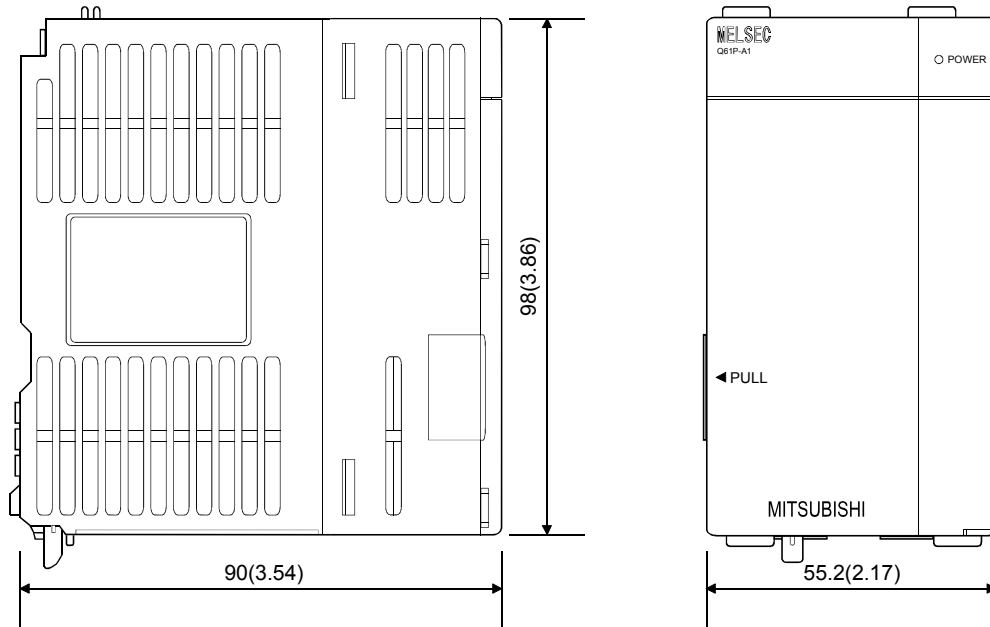

(2) Q64P

[Unit: mm (inch)]

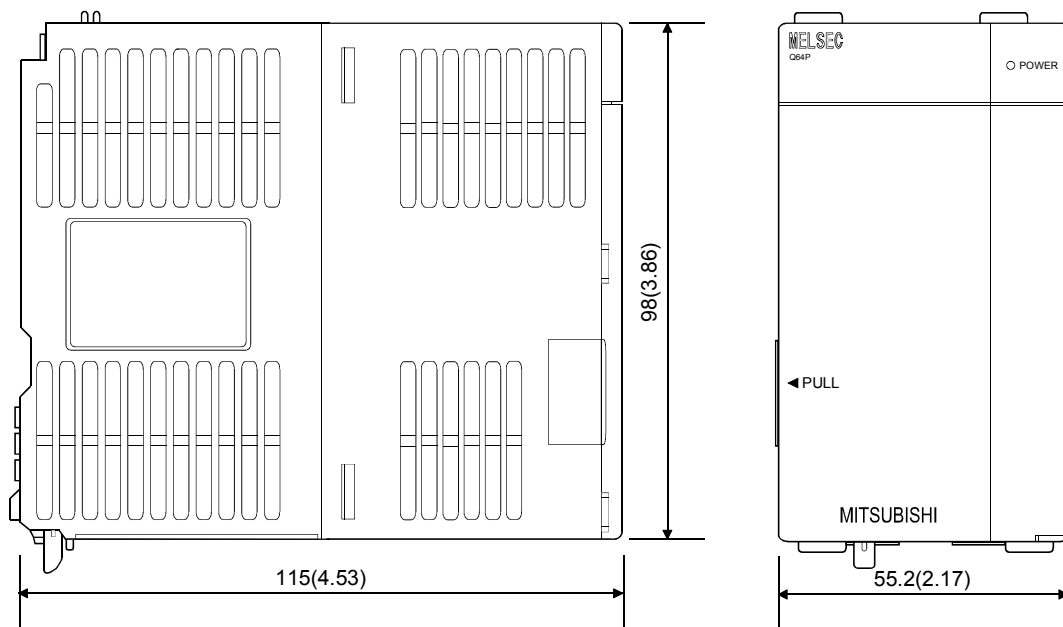

APPENDIX 2.6 Battery holder unit (Q170HBATC)

(1) Battery holder unit (Q170HBATC)

[Unit: mm (inch)]

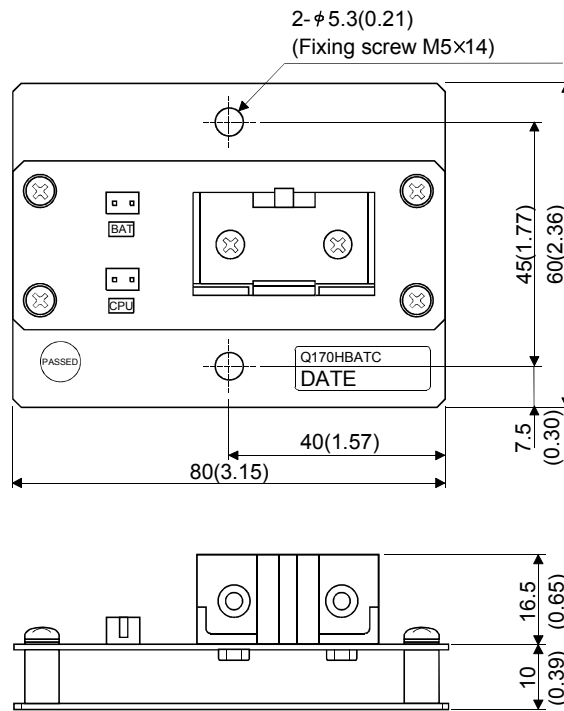

APPENDIX 2.7 Connector

- (1) Honda connectors make (HDR model)
 (Cable connector for the SSC I/F communication cable/
 teaching unit)

Number of pins	Type	
	Connector	Connector case
14	HDR-E14MG1	HDR-E14LPA5
26	HDR-E26FG1	HDR-E26LPA5

Specified tool: FHAT-0029/FHPT-0004C

Maker: Honda connectors

These tools are not sold in Mitsubishi. Please purchase them by customers.

Type Connector : HDR-E14MG1
 Connector case: HDR-E14LPA5

Type Connector : HDR-E26FG1
 Connector case: HDR-E26LPA5

[Unit: mm (inch)]

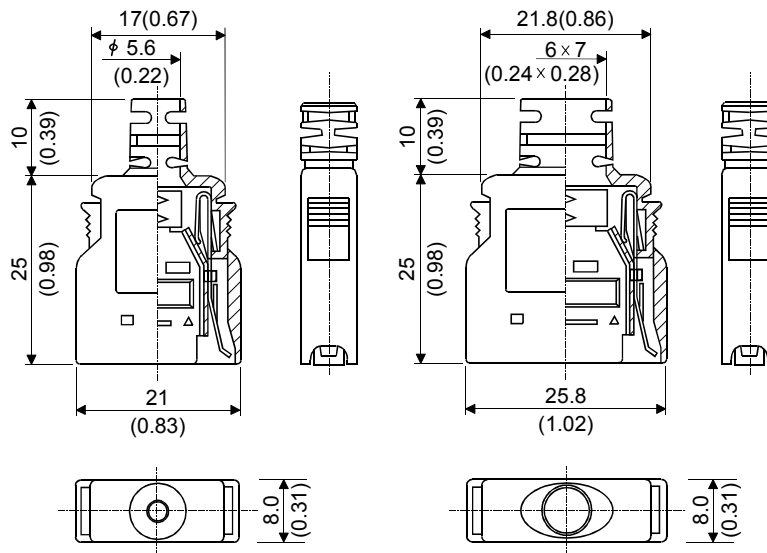

(2) Sumitomo 3M make (MDR type)
 (Cable connector for the serial absolute synchronous encoder)

Number of pins	Type	Type	
		Connector	Connector case
20	Solder connection type (Quick release metal latch type)	10120-3000VE	10320-52F0-008
	Solder connection type (Threaded type)	10120-3000VE	10320-52A0-008
	Insulation displacement type (Quick release metal latch type)	10120-6000EL(Notes)	10320-3210-000(Notes)

(Note): These connectors are not options. Please purchase them by customer.

(a) Solder connection type(Quick release metal latch type)

Type Connector : 10120-3000VE
 Connector case: 10320-52F0-008

[Unit: mm (inch)]

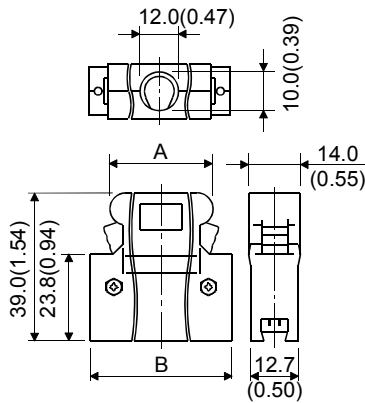

Number of pins	A	B
20 pin	22.0(0.87)	33.3(1.31)

(b) Solder connection type(Threaded type)

Type Connector : 10120-3000VE
 Connector case: 10320-52A0-008

[Unit: mm (inch)]

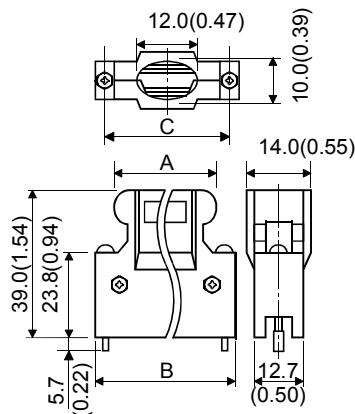

Number of pins	A	B	C
20 pin	22.0(0.87)	33.3(1.31)	27.4(1.08)

(c) Insulation displacement type(Quick release metal latch type)

Type Connector : 10120-6000EL

Connector case: 10320-3210-000

[Unit: mm (inch)]

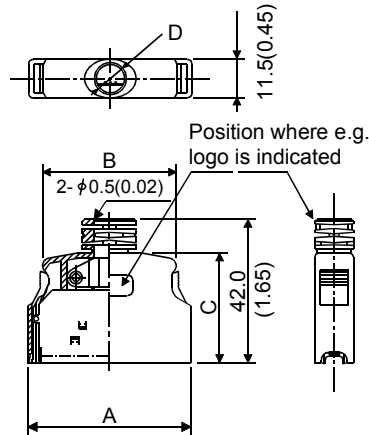

Number of pins	A	B	C	D
20 pin	29.7(1.17)	20.9(0.82)	33.0(1.30)	φ6.7

(3) SSCNET III cable connector

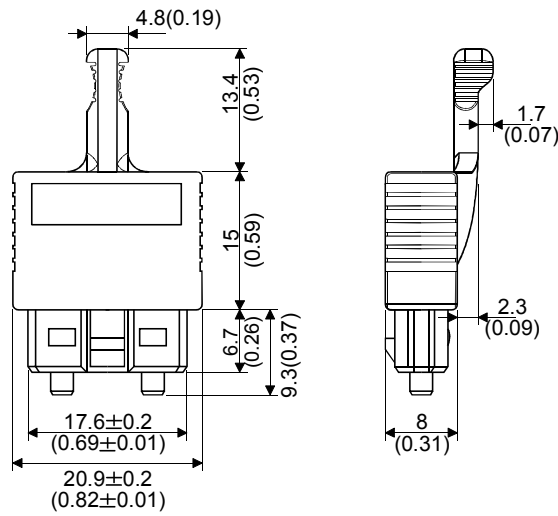

(4) Hirose Electric make (DF3 model) (Battery cable connector)

Type Connector : DF3-2S-2C
Terminal : DF3-2428SCC

[Unit: mm (inch)]

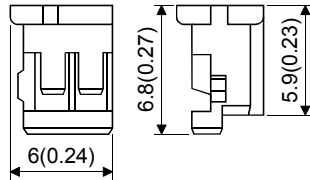

(5) Q170TUD3CBL(A31TU-D3□ side connector)

Type Connector : DB-25SF-N (Maker : Japan Aviation Electronics Industry)

Screw lock : D20418-J3 (Maker : Japan Aviation Electronics Industry)

Installation plate : Not for sale

Circular clamp : DB20962 (Maker : Japan Aviation Electronics Industry)

(a) Connector

[Unit: mm (inch)]

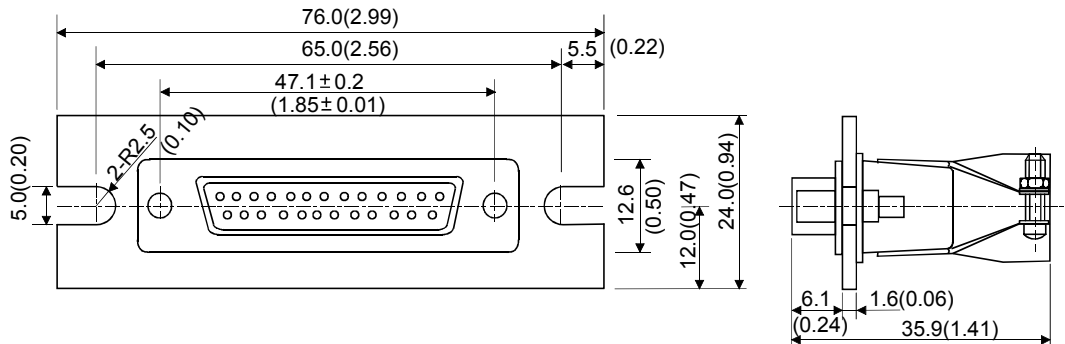

(b) Control panel fixing processing dimension

[Unit: mm (inch)]

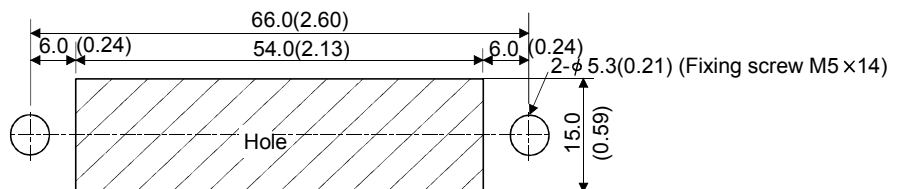

(6) Japan Aviation Electronics Industry make
(Cable connector for the teaching unit)

Type Connector : DB-25SF-N

[Unit: mm (inch)]

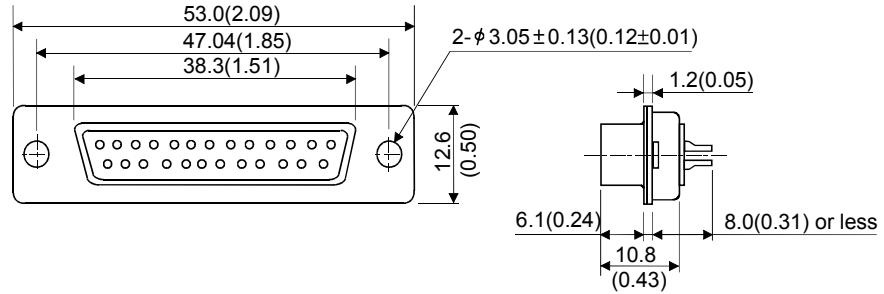

(Note) : Give the processing of the control panel referring to the above chart at cable producing.

(7) A31TUD3TM

Type Connector : 17JE-23250-02(D8A) (Maker : DDK)

[Unit: mm (inch)]

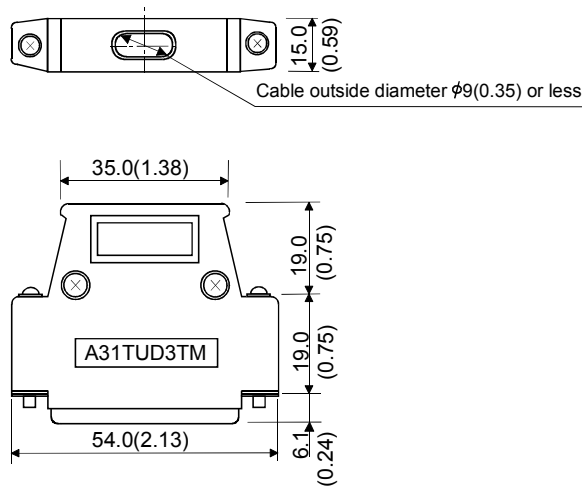

APPENDICES

APPENDIX 2.8 Manual pulse generator (MR-HDP01)

[Unit: mm (inch)]

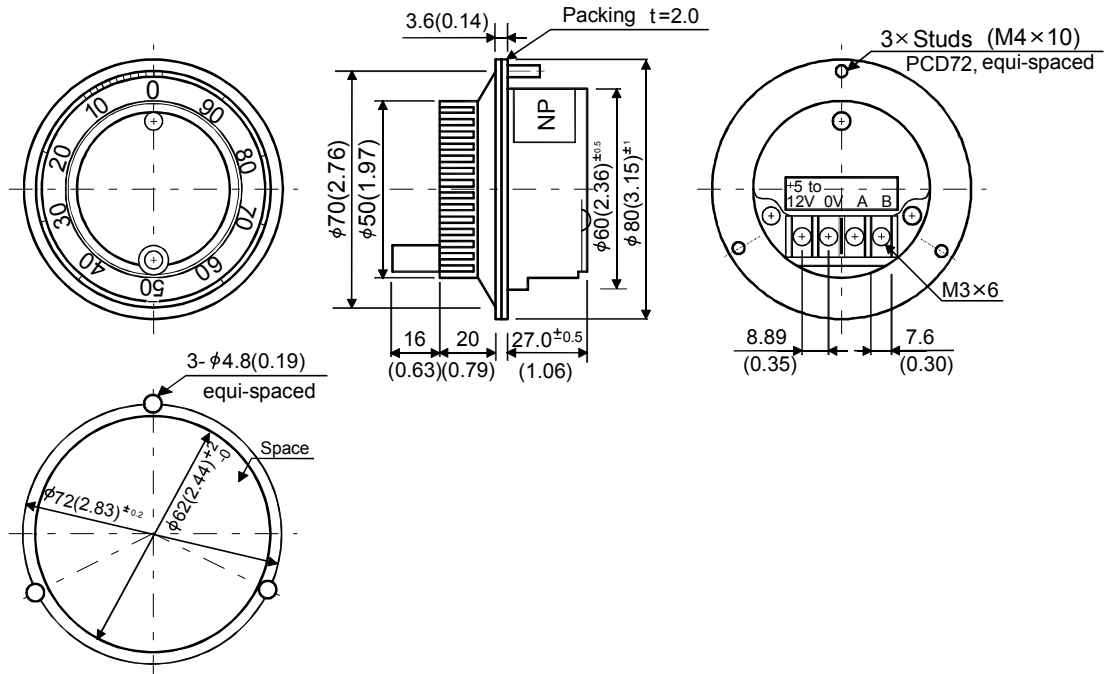

The figure of processing a disc

APPENDIX 2.9 Serial absolute synchronous encoder (Q170ENC)

[Unit: mm (inch)]

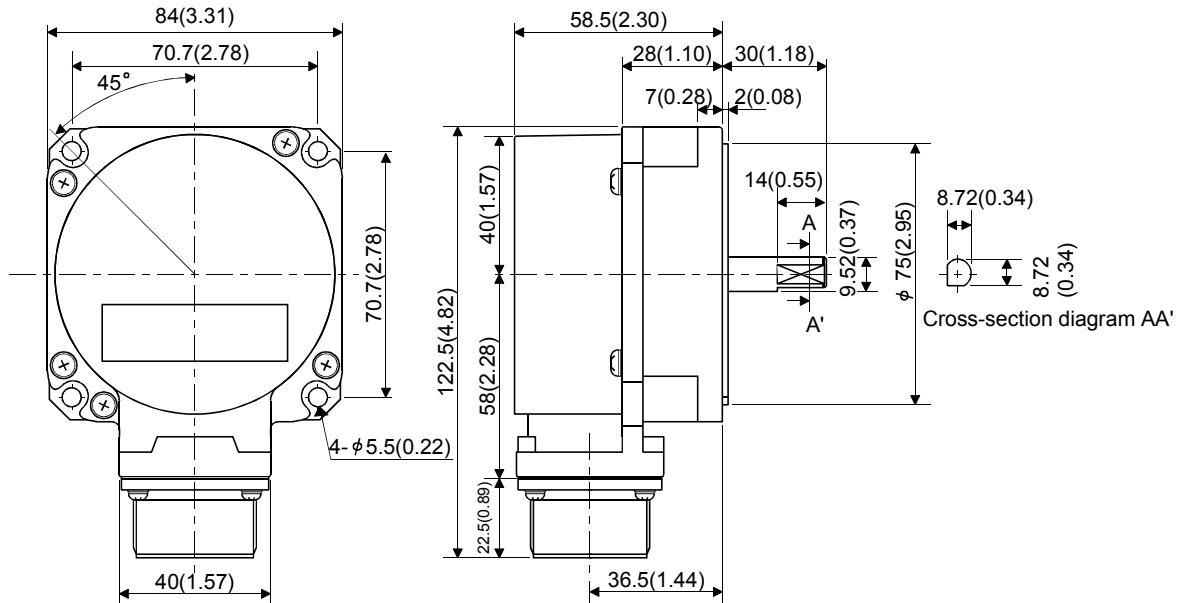

APPENDIX 2.10 Teaching unit (A31TU-D3□/A31TU-DN□)

[Unit: mm (inch)]

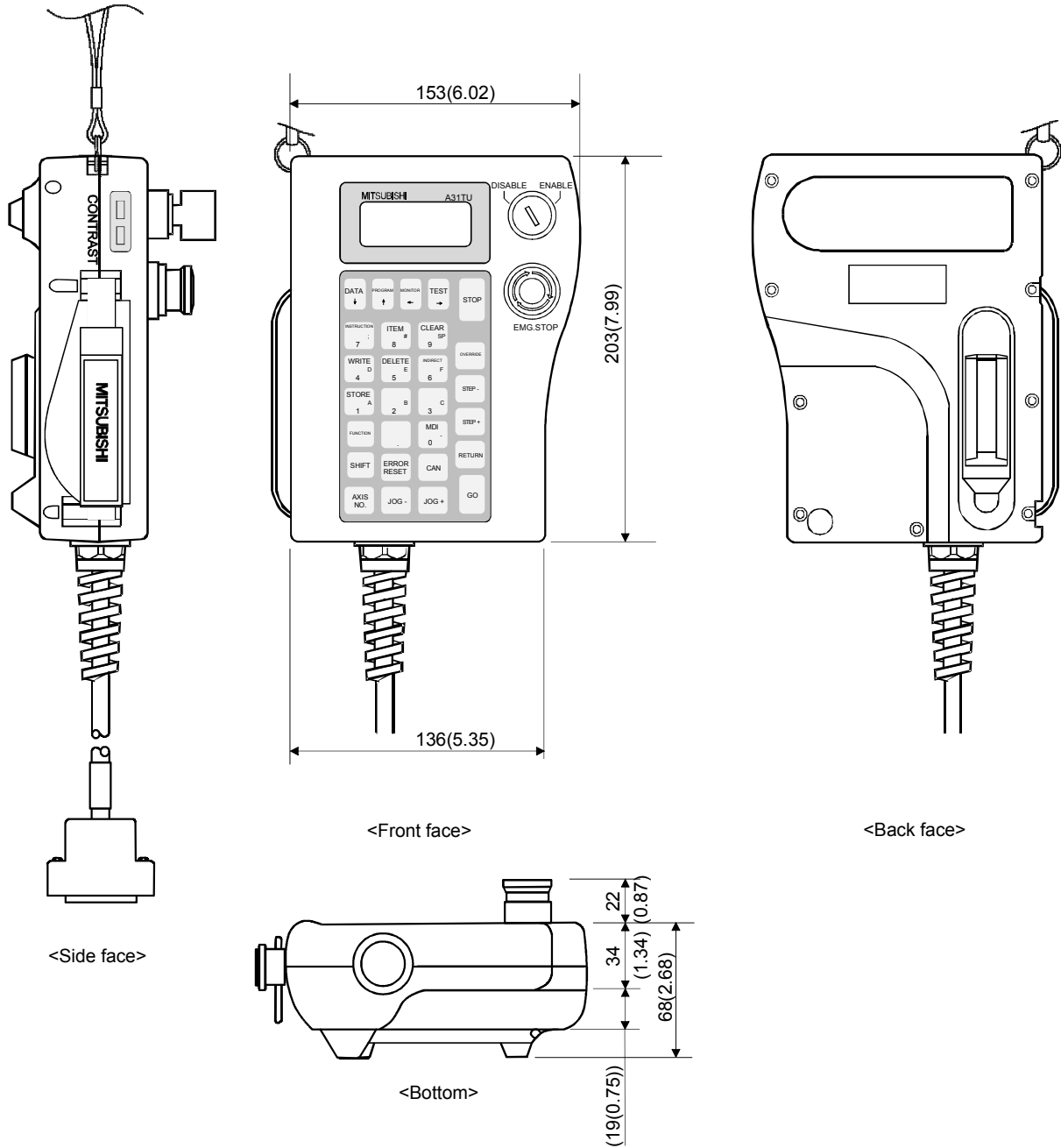

WARRANTY

Please confirm the following product warranty details before using this product.

1. Gratis Warranty Term and Gratis Warranty Range

We will repair any failure or defect hereinafter referred to as "failure" in our FA equipment hereinafter referred to as the "Product" arisen during warranty period at no charge due to causes for which we are responsible through the distributor from which you purchased the Product or our service provider. However, we will charge the actual cost of dispatching our engineer for an on-site repair work on request by customer in Japan or overseas countries. We are not responsible for any on-site readjustment and/or trial run that may be required after a defective unit are repaired or replaced.

[Gratis Warranty Term]

The term of warranty for Product is thirty six (36) months after your purchase or delivery of the Product to a place designated by you or forty two (42) months from the date of manufacture whichever comes first "Warranty Period". Warranty period for repaired Product cannot exceed beyond the original warranty period before any repair work.

[Gratis Warranty Range]

- (1) You are requested to conduct an initial failure diagnosis by yourself, as a general rule.
It can also be carried out by us or our service company upon your request and the actual cost will be charged. However, it will not be charged if we are responsible for the cause of the failure.
- (2) This limited warranty applies only when the condition, method, environment, etc. of use are in compliance with the terms and conditions and instructions that are set forth in the instruction manual and user manual for the Product and the caution label affixed to the Product.
- (3) Even during the term of warranty, the repair cost will be charged on you in the following cases;
 - 1) A failure caused by your improper storing or handling, carelessness or negligence, etc., and a failure caused by your hardware or software problem
 - 2) A failure caused by any alteration, etc. to the Product made on your side without our approval
 - 3) A failure which may be regarded as avoidable, if your equipment in which the Product is incorporated is equipped with a safety device required by applicable laws and has any function or structure considered to be indispensable according to a common sense in the industry
 - 4) A failure which may be regarded as avoidable if consumable parts designated in the instruction manual, etc. are duly maintained and replaced
 - 5) Any replacement of consumable parts (battery, fan, etc.)
 - 6) A failure caused by external factors such as inevitable accidents, including without limitation fire and abnormal fluctuation of voltage, and acts of God, including without limitation earthquake, lightning and natural disasters
 - 7) A failure generated by an unforeseeable cause with a scientific technology that was not available at the time of the shipment of the Product from our company
 - 8) Any other failures which we are not responsible for or which you acknowledge we are not responsible for

2. Onerous Repair Term after Discontinuation of Production

- (1) We may accept the repair at charge for another seven (7) years after the production of the product is discontinued.
The announcement of the stop of production for each model can be seen in our Sales and Service, etc.
- (2) Please note that the Product (including its spare parts) cannot be ordered after its stop of production.

3. Service in overseas countries

Our regional FA Center in overseas countries will accept the repair work of the Product; However, the terms and conditions of the repair work may differ depending on each FA Center. Please ask your local FA center for details.

4. Exclusion of Loss in Opportunity and Secondary Loss from Warranty Liability

Whether under or after the term of warranty, we assume no responsibility for any damages arisen from causes for which we are not responsible, any losses of opportunity and/or profit incurred by you due to a failure of the Product, any damages, secondary damages or compensation for accidents arisen under a specific circumstance that are foreseen or unforeseen by our company, any damages to products other than the Product, and also compensation for any replacement work, readjustment, start-up test run of local machines and the Product and any other operations conducted by you.

5. Change of Product specifications

Specifications listed in our catalogs, manuals or technical documents may be changed without notice.

6. Precautions for Choosing the Products

- (1) For the use of our Motion controller, its applications should be those that may not result in a serious damage even if any failure or malfunction occurs in Motion controller, and a backup or fail-safe function should operate on an external system to Motion controller when any failure or malfunction occurs.
- (2) Our Motion controller is designed and manufactured as a general purpose product for use at general industries. Therefore, applications substantially influential on the public interest for such as atomic power plants and other power plants of electric power companies, and also which require a special quality assurance system, including applications for railway companies and government or public offices are not recommended, and we assume no responsibility for any failure caused by these applications when used.

In addition, applications which may be substantially influential to human lives or properties for such as airlines, medical treatments, railway service, incineration and fuel systems, man-operated material handling equipment, entertainment machines, safety machines, etc. are not recommended, and we assume no responsibility for any failure caused by these applications when used.

We will review the acceptability of the abovementioned applications, if you agree not to require a specific quality for a specific application. Please contact us for consultation.

MOTION CONTROLLER Qseries (Q173HCPU/Q172HCPU) User's Manual



HEAD OFFICE : TOKYO BUILDING, 2-7-3 MARUNOUCHI, CHIYODA-KU, TOKYO 100-8310, JAPAN
NAGOYA WORKS : 1-14, YADA-MINAMI 5-CHOME, HIGASHI-KU, NAGOYA, JAPAN

MODEL	Q173H-U-E
MODEL CODE	1XB910
IB(NA)-0300110-D(1112)MEE	

When exported from Japan, this manual does not require application to the Ministry of Economy, Trade and Industry for service transaction permission.