

Programmable Controller

MELSEC iQ-F
series



MELSEC iQ-F
FX5-ENET/IP User's Manual

SAFETY PRECAUTIONS

(Read these precautions before use.)

Before using this product, please read this manual and the relevant manuals introduced in this manual carefully and pay full attention to safety in order to handle the product correctly.

This manual classifies the safety precautions into two categories: [⚠️ WARNING] and [⚠️ CAUTION].

 WARNING	Indicates that incorrect handling may cause hazardous conditions, resulting in death or severe injury.
 CAUTION	Indicates that incorrect handling may cause hazardous conditions, resulting in minor or moderate injury or property damage.

Depending on the circumstances, procedures indicated by [⚠️ CAUTION] may also cause severe injury.

It is important to follow all precautions for personal safety.



Store this manual in a safe place so that it can be read whenever necessary. Always forward it to the end user.

[DESIGN PRECAUTIONS]

WARNING

- Make sure to set up the following safety circuits outside the PLC to ensure safe system operation even during external power supply problems or PLC failure. Otherwise, malfunctions may cause serious accidents.
 - Most importantly, set up the following: an emergency stop circuit, a protection circuit, an interlock circuit for opposite movements (such as normal vs. reverse rotation), and an interlock circuit (to prevent damage to the equipment at the upper and lower positioning limits).
 - Note that when the CPU module detects an error, such as a watchdog timer error, during self-diagnosis, all outputs are turned off. Also, when an error that cannot be detected by the CPU module occurs in an input/output control block, output control may be disabled. External circuits and mechanisms should be designed to ensure safe machinery operation in such a case.
 - Note that when an error occurs in a relay, transistor or triac of an output circuit, the output might stay on or off. For output signals that may lead to serious accidents, external circuits and mechanisms should be designed to ensure safe machinery operation in such a case.
 - In an output circuit, when a load current exceeding the current rating or an overcurrent caused by a load short-circuit flows for a long time, it may cause smoke and fire. To prevent this, configure an external safety circuit, such as a fuse.
 - For the operating status of each station after a communication failure of the network, refer to relevant manuals for the network. Incorrect output or malfunction may result in an accident.
 - Construct an interlock circuit in the program so that the whole system always operates on the safe side before executing the control (for data change) of the PLC in operation. Read the manual thoroughly and ensure complete safety before executing other controls (for program change, parameter change, forcible output and operation status change) of the PLC in operation. Otherwise, the machine may be damaged and accidents may occur due to erroneous operations.
 - Especially, in the case of a control from an external device to a remote programmable controller, immediate action cannot be taken for a problem on the programmable controller due to a communication failure. Determine the handling method as a system when communication failure occurs along with configuration of interlock circuit on a program, by considering the external equipment and CPU module.
-

WARNING

- Do not write any data to the "system area" and "write-protect area" of the buffer memory in the intelligent function module. Executing data writing to the "system area" or "write-protect area" may cause malfunction of the programmable controller alarm. For the "system area" or "write-protect area", refer to  Page 142 Buffer Memory.
- If a communication cable is disconnected, the network may be unstable, resulting in a communication failure of multiple stations. Construct an interlock circuit in the program so that the system always operates on the safe side even if communications fail. Incorrect output or malfunction may result in an accident.
- For the operating status of each EtherNet/IP device after a communication failure, refer to  Page 109 TROUBLESHOOTING in this manual. Incorrect output or malfunction due to a communication failure may result in an accident.
- Configure an interlock circuit in the program to ensure that the entire system will always operate safely even if communications fail in multiple EtherNet/IP devices. Failure to do so may result in an accident due to an incorrect output or malfunction.

[DESIGN PRECAUTIONS]

CAUTION

- Do not install the control lines or communication cables together with the main circuit lines or power cables. Keep a distance of 100 mm or more between them. Failure to do so may result in malfunction due to noise.
- When an inductive load such as a lamp, heater, or solenoid valve is controlled, a large current (approximately ten times greater than normal) may flow when the output is turned from off to on. Take proper measures so that the flowing current dose not exceed the value corresponding to the maximum load specification of the resistance load.
- Do not power off the CPU module or reset the CPU module while the settings are being written. Doing so will make the data in the flash ROM undefined. The values need to be set in the buffer memory and written to the flash ROM again. Doing so also may cause malfunction or failure of the module.

[SECURITY PRECAUTIONS]

WARNING

- To maintain the security (confidentiality, integrity, and availability) of the programmable controller and the system against unauthorized access, denial-of-service (DoS) attacks, computer viruses, and other cyberattacks from unreliable networks and devices via network, take appropriate measures such as firewalls, virtual private networks (VPNs), and antivirus solutions.

[INSTALLATION PRECAUTIONS]

WARNING

- Make sure to cut off all phases of the power supply externally before attempting installation or wiring work.
Failure to do so may cause electric shock or damage to the product.
 - Use the product within the generic environment specifications described in the User's Manual (Hardware) of the CPU module used.
Never use the product in areas with excessive dust, oily smoke, conductive dusts, corrosive gas (salt air, Cl₂, H₂S, SO₂ or NO₂), flammable gas, vibration or impacts, or expose it to high temperature, condensation, or rain and wind.
If the product is used in such conditions, electric shock, fire, malfunctions, deterioration or damage may occur.
-

[INSTALLATION PRECAUTIONS]

CAUTION

- Do not touch the conductive parts of the product directly. Doing so may cause device failures or malfunctions.
 - When drilling screw holes or wiring, make sure that cutting and wiring debris do not enter the ventilation slits of the PLC. Failure to do so may cause fire, equipment failures or malfunctions.
 - For the product supplied together with a dust proof sheet, the sheet should be affixed to the ventilation slits before the installation and wiring work to prevent foreign objects such as cutting and wiring debris. However, when the installation work is completed, make sure to remove the sheet to provide adequate ventilation.
Failure to do so may cause fire, equipment failures or malfunctions.
 - Install the product on a flat surface. If the mounting surface is rough, undue force will be applied to the PC board, thereby causing nonconformities.
 - Install the product securely using a DIN rail or mounting screws.
 - Work carefully when using a screwdriver such as installation of the product. Failure to do so may cause damage to the product or accidents.
 - Connect the extension cables, peripheral device cables, input/output cables and battery connecting cable securely to their designated connectors. Loose connections may cause malfunctions.
 - Turn off the power to the PLC before attaching or detaching the following devices. Failure to do so may cause equipment failures or malfunctions.
 - Peripheral devices, expansion board, expansion adapter, and connector conversion adapter
 - Extension modules, bus conversion module, and connector conversion module
 - Battery
-

[WIRING PRECAUTIONS]

WARNING

- Make sure to cut off all phases of the power supply externally before attempting installation or wiring work. Failure to do so may cause electric shock or damage to the product.
 - Make sure to attach the terminal cover, provided as an accessory, before turning on the power or initiating operation after installation or wiring work. Failure to do so may cause electric shock.
 - The temperature rating of the cable should be 80°C or more.
 - Make sure to properly wire to the spring clamp terminal block in accordance with the following precautions. Failure to do so may cause electric shock, equipment failures, a shortcircuit, wire breakage, malfunctions, or damage to the product.
 - The disposal size of the cable end should follow the dimensions described in the manual.
 - Twist the ends of stranded wires and make sure that there are no loose wires.
 - Do not solder-plate the electric wire ends.
 - Do not connect more than the specified number of wires or electric wires of unspecified size.
 - Affix the electric wires so that neither the terminal block nor the connected parts are directly stressed.
-

[WIRING PRECAUTIONS]

CAUTION

- Perform class D grounding (grounding resistance: 100 Ω or less) of the grounding terminal on the CPU module and extension modules with a wire 2 mm² or thicker. Do not use common grounding with heavy electrical systems (refer to the User's Manual (Hardware) of the CPU module used).
 - Individually ground the FG terminal of the programmable controller with a ground resistance of 100 Ω or less. Failure to do so may result in electric shock or malfunction.
 - Install module so that excessive force will not be applied to terminal blocks, or communication cables. Failure to do so may result in wire damage/breakage or PLC failure.
 - Make sure to observe the following precautions in order to prevent any damage to the machinery or accidents due to malfunction of the PLC caused by abnormal data written to the PLC due to the effects of noise.
 - Do not bundle the control line and communication cables together with or lay them close to the main circuit, high-voltage line, load line or power line. As a guideline, lay the power line, control line and communication cables at least 100 mm away from the main circuit, high-voltage line, load line or power line.
 - Ground the shield of the shielded wire or shielded cable at one point on the PLC. However, do not use common grounding with heavy electrical systems.
 - For Ethernet cables to be used in the system, select the ones that meet the specifications described in  Page 46 Wiring Products. If not, normal data transmission is not guaranteed.
-

[STARTUP AND MAINTENANCE PRECAUTIONS]

WARNING

- Do not touch any terminal while the PLC's power is on. Doing so may cause electric shock or malfunctions.
 - Before cleaning or retightening terminals, cut off all phases of the power supply externally. Failure to do so in the power ON status may cause electric shock.
 - Before modifying the program in operation, forcible output, running or stopping the PLC, read through this manual carefully, and ensure complete safety. An operation error may damage the machinery or cause accidents.
 - Do not change the program in the PLC from two or more peripheral equipment devices at the same time. (i.e. from an engineering tool and a GOT) Doing so may cause destruction or malfunction of the PLC program.
-

[STARTUP AND MAINTENANCE PRECAUTIONS]

CAUTION

- When connecting an external device with a CPU module or intelligent function module to modify data of a running programmable controller, configure an interlock circuit in the program to ensure that the entire system will always operate safely. For other forms of control (such as program modification, parameter change, forced output, or operating status change) of a running programmable controller, read the relevant manuals carefully and ensure that the operation is safe before proceeding. Improper operation may damage machines or cause accidents.
 - Especially, when a remote programmable controller is controlled by an external device, immediate action cannot be taken if a problem occurs in the programmable controller due to a communication failure. To prevent this, configure an interlock circuit in the program, and determine corrective actions to be taken between the external device and CPU module in case of a communication failure.
 - Do not disassemble or modify the PLC. Doing so may cause fire, equipment failures, or malfunctions. For repair, contact your local Mitsubishi Electric representative.
-

CAUTION

- Turn off the power to the PLC before attaching or detaching the following devices. Failure to do so may cause equipment failures or malfunctions.
 - Peripheral devices, expansion board, expansion adapter, and connector conversion adapter
 - Extension modules, bus conversion module, and connector conversion module
 - Battery
 - Read relevant manuals carefully and ensure the safety before performing online operations (operation status change) with peripheral devices connected to the CPU modules of other stations. Improper operation may damage machines or cause accidents.
-

[OPERATION PRECAUTIONS]

CAUTION

- Construct an interlock circuit in the program so that the whole system always operates on the safe side before executing the control (for data change) of the PLC in operation.
Read the manual thoroughly and ensure complete safety before executing other controls (for program change, parameter change, forcible output and operation status change) of the PLC in operation. Otherwise, the machine may be damaged and accidents may occur by erroneous operations.
 - Do not power off the CPU module or reset the CPU module while the setting values in the buffer memory are being written to the flash ROM in the intelligent function module. Doing so will make the data in the flash ROM card undefined. The values need to be set in the buffer memory and written to the flash ROM again. Doing so can cause malfunction or failure of the module.
 - Note that the whole system may not be reset by the RUN/STOP/RESET switch when the CPU module or intelligent function module detects an error, such as a watchdog timer error, during self-diagnosis. In such cases, turn the power off and on again.
-

[DISPOSAL PRECAUTIONS]

CAUTION

- Please contact a certified electronic waste disposal company for the environmentally safe recycling and disposal of your device.
-

[TRANSPORTATION PRECAUTIONS]

CAUTION

- The PLC is a precision instrument. During transportation, avoid impacts larger than those specified in the general specifications of the User's Manual (Hardware) of the CPU module by using dedicated packaging boxes and shock-absorbing palettes. Failure to do so may cause failures in the PLC. After transportation, verify operation of the PLC and check for damage of the mounting part, etc.
-

INTRODUCTION

This manual contains text, diagrams and explanations which will guide the reader in the correct installation, safe use and operation of the FX5-ENET/IP Ethernet module of iQ-F series.

It should be read and understood before attempting to install or use the unit. Store this manual in a safe place so that you can read it whenever necessary.

Always forward it to the end user.

Regarding use of this product

- This product has been manufactured as a general-purpose part for general industries, and has not been designed or manufactured to be incorporated in a device or system used in purposes related to human life.
- Before using the product for special purposes such as nuclear power, electric power, aerospace, medicine or passenger movement vehicles, consult Mitsubishi Electric.
- This product has been manufactured under strict quality control. However when installing the product where major accidents or losses could occur if the product fails, install appropriate backup or failsafe functions in the system.

Note

- If in doubt at any stage during the installation of the product, always consult a professional electrical engineer who is qualified and trained in the local and national standards. If in doubt about the operation or use, please consult the nearest Mitsubishi Electric representative.
- Mitsubishi Electric will not accept responsibility for actual use of the product based on these illustrative examples.
- This manual content, specification etc. may be changed, without a notice, for improvement.
- The information in this manual has been carefully checked and is believed to be accurate; however, if you notice a doubtful point, an error, etc., please contact the nearest Mitsubishi Electric representative. When doing so, please provide the manual number given at the end of this manual.

MEMO

CONTENTS

SAFETY PRECAUTIONS	1
INTRODUCTION	7
RELEVANT MANUALS	12
TERMS	12
GENERIC TERMS AND ABBREVIATIONS	12
CHAPTER 1 OUTLINE	14
CHAPTER 2 SPECIFICATIONS	16
2.1 General Specifications	16
2.2 Power Supply Specifications	16
2.3 Performance Specifications	17
2.4 Part Names	19
LED display	20
CHAPTER 3 PROCEDURES BEFORE OPERATION	21
CHAPTER 4 FUNCTION	22
4.1 Function List	22
4.2 EtherNet/IP Communication Functions	23
Class1 instance communications	25
Class3 message communications	32
UCMM message communications	36
Communication Status Setting Function When a CPU Stop Error Occurs	40
CHAPTER 5 SYSTEM CONFIGURATION	41
5.1 EtherNet/IP Configuration	41
5.2 General-purpose Ethernet Communication Configuration	42
5.3 Available Software Packages	42
CHAPTER 6 WIRING	43
6.1 Grounding	43
6.2 Wiring Method	45
6.3 Wiring Products	46
CHAPTER 7 PARAMETER SETTINGS	47
7.1 Procedure for Setting Parameters	47
7.2 Required Settings	48
Mode	48
7.3 Basic Setting	48
Own Node Setting	49
Operational Setting	49
BACnet function setting	50
External Device Configuration	52
7.4 Application Settings	53
Simple CPU communication settings	53
Security	54
7.5 Setting EtherNet/IP Communications (Starting EtherNet/IP Configuration Tool for FX5-ENET/IP)	55

7.6	Writing Parameters	56
CHAPTER 8 EtherNet/IP Configuration Tool for FX5-ENET/IP		57
8.1	Window Structure	57
	Menu	58
	EtherNet/IP setting	65
	Device Library	67
	Network Detection	69
	Network configuration settings	75
	Setting Target Instance	98
	Operation information list	99
8.2	Procedure for Registering EtherNet/IP Devices	100
	Adding the EDS file	100
	Configuring settings online	103
	Configuring settings offline	103
8.3	Checking the Software Version	104
CHAPTER 9 PROGRAMMING		105
9.1	Program Example of Class 1 Instance Communications	105
	Program example	105
9.2	Program Example of UCMM Message Communications	107
	Program example	107
CHAPTER 10 TROUBLESHOOTING		109
10.1	Checking with LEDs	109
10.2	Checking the Module Status	111
	Module diagnostics	111
	Ethernet diagnostics	113
	Checking the buffer memory	117
	Event history function	117
10.3	Checking the Network Status	118
	Network diagnostics of EtherNet/IP Configuration Tool for FX5-ENET/IP	118
	Checking with the buffer memory	120
	PING test	120
10.4	Hardware Test	121
10.5	Troubleshooting by Symptom	122
10.6	List of Error Codes	124
	EtherNet/IP communication error	124
	Module error	128
	Ethernet communication error	132
10.7	List of Event Code	135
APPENDIX		139
Appendix 1 External Dimensions		139
Appendix 2 Standards		140
	Certification of UL, cUL standards	140
	Compliance with EC Directive (CE marking)	140
	Requirement for compliance with EMC Directive	140
	Caution for compliance with EC Directive	140
	Compliance with UKCA marking	140

Appendix 3 Module Label	141
Appendix 4 Buffer Memory	142
List of buffer memory addresses	142
Details of buffer memory addresses	148
Appendix 5 Details of Message Communication Support Command	166
Object list	166
Command explanations	166
Identity	168
Connection Manager	170
TCP/IP Interface	171
Ethernet Link	173
Appendix 6 Processing Time	176
RPI (Requested Packet Interval)	176
Transmission delay time	176
Appendix 7 Software Licenses and Copyrights	178
Appendix 8 Added and Changed Functions	179
INDEX	180
<hr/>	
REVISIONS	182
WARRANTY	183
TRADEMARKS	184

RELEVANT MANUALS

Manual name <manual number>	Description
MELSEC iQ-F FX5S/FX5UJ/FX5U/FX5UC User's Manual (Hardware) <SH-082452ENG>	Describes the details of hardware of the CPU module, including performance specifications, wiring, installation, and maintenance.
MELSEC iQ-F FX5 User's Manual (Application) <JY997D55401>	Describes the basic knowledge required for program design, functions of the CPU module, devices/labels, and parameters.
MELSEC iQ-F FX5 Programming Manual (Program Design) <JY997D55701>	Describes the specifications of ladder, ST, FBD/LD, and SFC programs, and labels.
MELSEC iQ-F FX5 Programming Manual (Instructions, Standard Functions/Function Blocks) <JY997D55801>	Describes the specifications of instructions and functions that can be used in programs.
MELSEC iQ-F FX5 User's Manual (Ethernet Communication) <JY997D56201>	Describes the Ethernet communication function of the CPU module built-in and the Ethernet module.
MELSEC iQ-F FX5-ENET/IP User's Manual <SH-082027ENG> (This manual)	Describes the FX5-ENET/IP.
MELSEC iQ-F FX5 User's Manual (BACnet) <SH-082218ENG>	BACnet functions of the Ethernet module.
MELSEC iQ-F FX5 User's Manual (SLMP) <JY997D56001>	Explains methods for the device that is communicating with the CPU module by SLMP to read and write the data of the CPU module.
GX Works3 Operating Manual <SH-081215ENG>	Describes the system configuration, parameter settings, and online operations of GX Works3.

TERMS

Unless otherwise specified, this manual uses the following terms.

For details on the FX3 devices that can be connected with the FX5, refer to the User's Manual (Hardware) of the CPU module to be used.

Terms	Description
EtherNet/IP	An industrial Ethernet protocol offered by ODVA
Adapter	The EtherNet/IP station type that corresponds to slave stations
Engineering tool	The product name of the software package for the MELSEC programmable controllers
Originator	Originator indicates an EtherNet/IP device that transmits a connection establishment request of EtherNet/IP
Client	An EtherNet/IP device that transmits commands to the external device
Server	An EtherNet/IP device that returns responses to the commands from the external device
Scanner	The EtherNet/IP station type that corresponds to the master station
Target	Target indicates an EtherNet/IP device that receives a connection establishment request of EtherNet/IP

GENERIC TERMS AND ABBREVIATIONS

Unless otherwise specified, this manual uses the following generic terms and abbreviations.

Generic term/abbreviation	Description
CIP	The abbreviation for Common Industrial Protocol. One of the open protocols of ODVA, a specialized application protocol for EtherNet/IP, DeviceNet and ControlNet.
EtherNet/IP device	A generic term for devices, personal computers, and other equipment connected by EtherNet/IP for data communication
Ethernet module	Different name for FX5-ENET/IP
FX5U CPU module	Generic term for FX5U-32MR/ES, FX5U-32MT/ES, FX5U-32MT/ESS, FX5U-64MR/ES, FX5U-64MT/ES, FX5U-64MT/ESS, FX5U-80MR/ES, FX5U-80MT/ES, FX5U-80MT/ESS, FX5U-32MR/DS, FX5U-32MT/DS, FX5U-32MT/DSS, FX5U-64MR/DS, FX5U-64MT/DS, FX5U-64MT/DSS, FX5U-80MR/DS, FX5U-80MT/DS, and FX5U-80MT/DSS
FX5UC CPU module	Generic term for FX5UC-32MT/D, FX5UC-32MT/DSS, FX5UC-64MT/D, FX5UC-64MT/DSS, FX5UC-96MT/D, FX5UC-96MT/DSS, FX5UC-32MT/DS-TS, FX5UC-32MT/DSS-TS, and FX5UC-32MR/DS-TS
FX5UJ CPU module	Generic term for FX5UJ-24MR/ES, FX5UJ-24MT/ES, FX5UJ-24MT/ESS, FX5UJ-40MR/ES, FX5UJ-40MT/ES, FX5UJ-40MT/ESS, FX5UJ-60MR/ES, FX5UJ-60MT/ES, and FX5UJ-60MT/ESS
GX Works3	The product name of the software package, SWnDND-GXW3, for the MELSEC programmable controllers (The 'n' represents a version.)

Generic term/abbreviation	Description
PPS	The abbreviation for Packets Per Second. It indicates the number of packets that can be processed in one second.
RPI	The abbreviation for Requested Packet Interval. It is the communication cycle determined by the originator during communications between EtherNet/IP devices.
SD memory card	Generic term for NZ1MEM-2GBSD, NZ1MEM-4GBSD, NZ1MEM-8GBSD, NZ1MEM-16GBSD, L1MEM-2GBSD and L1MEM-4GBSD SD memory cards The abbreviation for Secure Digital Memory Card. Device that stores data using flash memory.
TCP	The abbreviation for Transmission Control Protocol. In communications among programmable controllers and networked devices, this protocol establishes a connection between port numbers of the two devices to perform reliable data communications.
UDP	The abbreviation for User Datagram Protocol. This is a connectionless protocol and thereby its speed is faster than that of TCP, but less reliable. (Data may be lost or not be received in correct order.)
Intelligent function module	Generic term for FX5 intelligent function modules and FX3 intelligent function modules
Peripheral device	Generic term for engineering tools and GOTs
Extension module	Generic term for FX5 extension modules, FX3 extension modules, and extension modules (extension cable type and extension connector type)
Battery	Different name for FX3U-32BL

1 OUTLINE

FX5-ENET/IP Ethernet module (hereinafter referred to as FX5-ENET/IP) is an intelligent function module for connecting to a EtherNet/IP network and general-purpose Ethernet.

EtherNet/IP communication

The module can communicate seamlessly with an EtherNet/IP network by using the communication protocol CIP. FX5-ENET/IP functions as a scanner (originator/client) or an adapter (target/server) of the EtherNet/IP network.

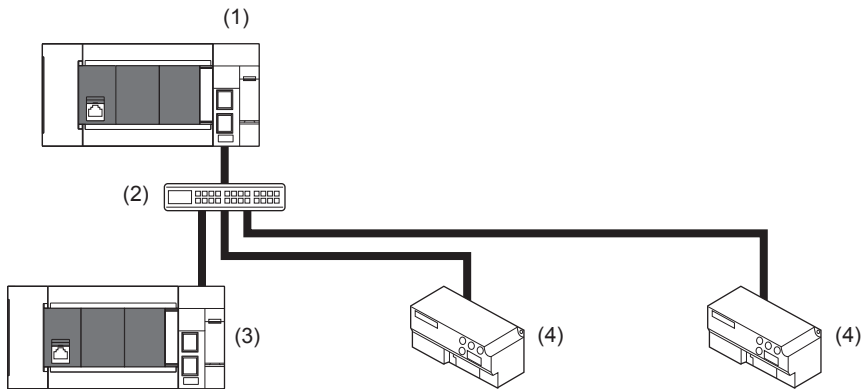

- (1) FX5-ENET/IP (scanner)
- (2) Hub
- (3) FX5-ENET/IP (adapter)
- (4) EtherNet/IP device (scanner/adapter)

General-purpose Ethernet communication

The module can be connected with a host system, such as a personal computer, by using the communication protocol TCP/UDP.

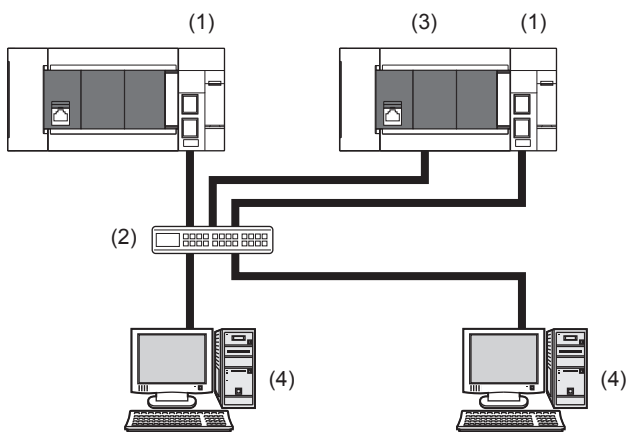

- (1) FX5-ENET/IP
- (2) Hub
- (3) CPU module
- (4) External device (personal computer)

2 SPECIFICATIONS

This chapter describes the FX5-ENET/IP specifications.

2.1 General Specifications

The items other than the following are equivalent to those of the CPU module.

For the general specification, refer to the following manual.

📖 MELSEC iQ-F FX5S/FX5UJ/FX5U/FX5UC User's Manual (Hardware)

Items	Specifications	
Dielectric withstand voltage	500 V AC for 1 minute	Between all terminals and ground terminal
Insulation resistance	10 M Ω or higher by 500 V DC insulation resistance tester	

2.2 Power Supply Specifications

The following table lists the power supply specifications.

Items		Specifications
Internal power supply	Power supply voltage	24 V DC
	Current consumption	110 mA

2.3 Performance Specifications

The following table lists the performance specifications.

Items		Specifications	
EtherNet/IP communications	Class 1 communications	Communication format	Standard EtherNet/IP
		Number of connections	32
		Communication data size	1444 bytes (per connection)
		Connection type	Point-to-point, multicast
		RPI (communication cycle)	2 to 60000 ms
		PPS (communication processing performance)	3000 pps (case of 128 bytes)
	Class 3 communications* ¹	Communication format	Standard EtherNet/IP
		Number of connections	32* ²
		Connection type	Point-to-point
	UCMM communications	Communication format	Standard EtherNet/IP
		Number of connections (number of simultaneous executions)	32* ²
		Communication data size	1414 bytes* ³
		Connection type	Point-to-point
	Transmission specifications	Data transmission speed	100 Mbps
		Communication mode	Full-duplex
		Transmission method	Base band
		Interface	RJ45 connector
		IP version	IPv4 is supported.
		Maximum segment length	100 m (length between hub and node)* ⁴
		Number of cascade connections	100BASE-TX 2 levels maximum* ⁵
	Network topology	Star topology, line topology	
Hub* ⁶	Hubs with 100BASE-TX ports* ⁷ can be used.		
Connection cable* ⁸	100BASE-TX Ethernet cable of category 5 or higher (STP cable)		
General-purpose Ethernet communication	Transmission specifications	Data transfer speed	100/10 Mbps
		Communication mode	Full-duplex or half-duplex* ⁶
		Transmission method	Base band
		Interface	RJ45 connector
		Maximum segment length	100 m (length between hub and node)* ⁴
		Number of cascade connections	100BASE-TX 2 levels maximum* ⁵ 10BASE-T 4 levels maximum* ⁵
	Protocol type* ⁹	MELSOFT connection, SLMP server (3E/1E frame), socket communication, simple CPU communication, BACnet/IP	
	Number of connections	Total of 32 connections* ¹⁰ (Up to 32 external devices can access one FX5-ENET/IP module at the same time.)	
	Hub* ⁶	Hubs with 100BASE-TX or 10BASE-T ports* ¹¹ can be used.	
	Connection cable* ⁸	100BASE-TX Ethernet cable of category 5 or higher (STP cable) 10BASE-T Ethernet cable of category 3 or higher (STP/UTP cable)	
	Number of ports	2* ¹²	
Number of occupied I/O points	8 points		
Applicable CPU module	<ul style="list-style-type: none"> FX5UJ CPU module (From the first) FX5U CPU module (Ver. 1.110 or later) FX5UC CPU module*¹³ (Ver. 1.110 or later) 		
Applicable engineering tool	GX Works3	<ul style="list-style-type: none"> FX5UJ CPU module (Ver.1.060N or later) FX5U/FX5UC CPU module (Ver.1.050C or later) 	
	EtherNet/IP Configuration Tool for FX5-ENET/IP	Ver.1.00A or later	
Number of connectable units	1 module		

- *1 Class3 communication supports the server functions.
- *2 The total number of connections for Class 3 communications and UCMM communications is 32.
- *3 This size is the maximum size which can be specified to 'Data length' of Class1 communication input data area of the request command during the client operation.
During the sever operation, since the FX5-ENET/IP automatically responds according to the request command received from the client, the maximum size is not prescribed.
- *4 For maximum segment length (length between hubs), consult the manufacturer of the hub used.
- *5 This number applies when a repeater hub is used. When using a switching hub, check the number of cascaded stages with the manufacturer of the hub to be used.
- *6 IEEE802.3x flow control is not supported.
- *7 The ports must comply with the IEEE802.3 100BASE-TX standards.
- *8 A straight/cross cable can be used.
- *9 For the versions compatible with each protocol, refer to  Page 179 Added and Changed Functions.
- *10 The first device for MELSOFT connection is not included in the number of connections. (The second and the following devices are included.)
The EtherNet/IP communication is not included in the number of connections.
- *11 The ports must comply with the IEEE802.3 100BASE-TX or IEEE802.3 10BASE-T standards.
- *12 Since the IP address is shared by two ports, only one address can be set.
- *13 FX5-CNV-IFC or FX5-C1PS-5V is necessary to connect FX5-ENET/IP to the FX5UC CPU module.

Point

- If the destination device of the FX5-ENET/IP does not respond due to power off or other reasons, Ethernet communication of the FX5-ENET/IP may get delayed by up to 500 ms.
- In the case of general-purpose Ethernet communication, when FX5-ENET/IP is connected with a hub, it distinguishes between 100BASE-TX and 10BASE-T and between full-duplex and half-duplex communication modes according to the hub. Set the hub to the half-duplex mode if the hub does not have the auto-negotiation function.

Precautions

The operation of the following connections is not guaranteed. Check the operation before using the module.

- Connection using internet (general public line) (Internet-access service offered by an Internet service provider or a telecommunications carrier)
- Connection using firewall device(s)
- Connection using broadband router(s)
- Connection using wireless LAN

2.4 Part Names

This chapter describes the names of each part of the FX5-ENET/IP.

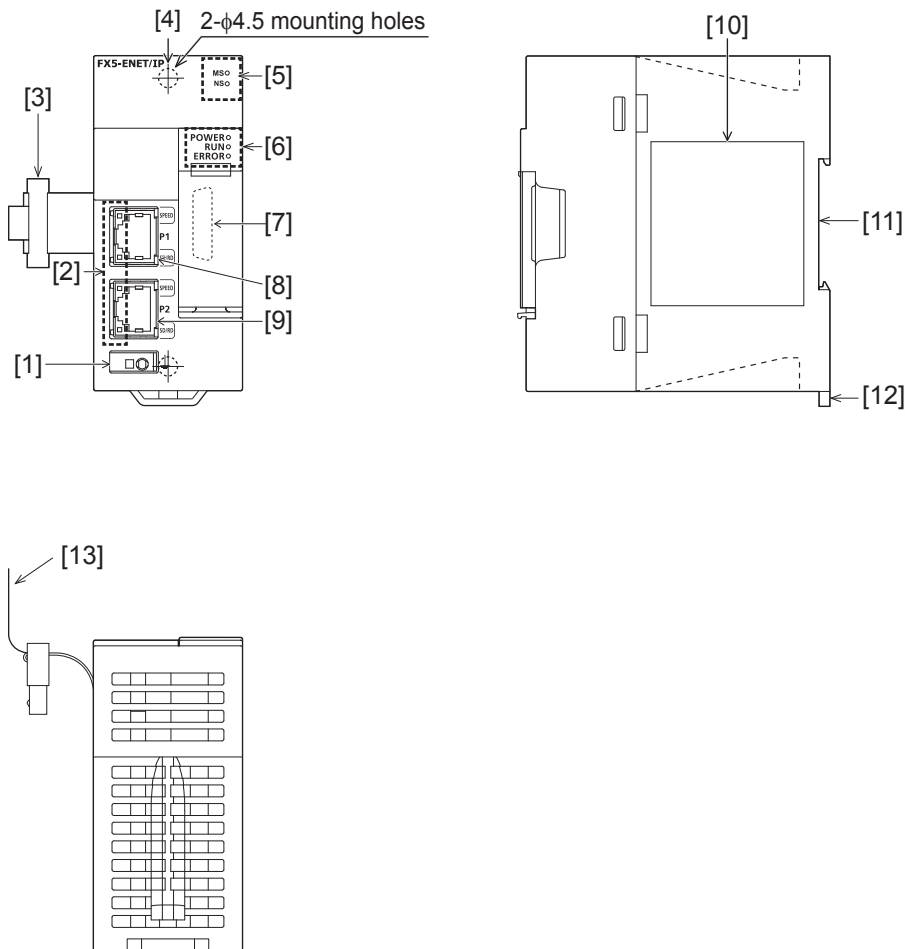

No.	Name	Description
[1]	External ground terminal	Connect an external ground. (Spring clamp terminal block)
[2]	Link status display LEDs	Displays the link status of module. (☞ Page 20 LED display)
[3]	Extension cable	Cable for connecting the module when adding the FX5-ENET/IP
[4]	Direct mounting hole	Screw holes (2-φ4.5, mounting screw: M4 screw) for direct installation
[5]	Module/network status display LEDs	Displays the module and network status. (☞ Page 20 LED display)
[6]	Operation status display LEDs	Refer to ☞ Page 20 LED display.
[7]	Extension connector (for next module)	Connector for connecting the extension cable of an extension module.
[8]	Modular jack for P1 (RJ-45) (with cap)	A port 1 connector for EtherNet/IP network and general-purpose Ethernet network. Connect an Ethernet cable.
[9]	Modular jack for P2 (RJ-45) (with cap)	A port 2 connector for EtherNet/IP network and general-purpose Ethernet network. Connect an Ethernet cable.
[10]	Name plate	The product model name, manufacturer's serial number etc. are shown.
[11]	DIN rail mounting groove	The module can be installed on DIN46277 rail (35 mm wide).
[12]	DIN rail mounting hook	Hook for mounting the module on a DIN rail of DIN46277 (35 mm wide).
[13]	Pullout tab	They are used when drawing out an extension cable.

LED display

The following table lists the LED display.

LED display		LED color	Description
MS		Green, Red	<p>Indicates the error status of the EtherNet/IP device.</p> <p>■LED color: Green</p> <ul style="list-style-type: none"> • On: Data communication possible • Flashing: No parameter setting • Off: Power failure occurred <p>■LED color: Red</p> <ul style="list-style-type: none"> • On: Moderate error or major error • Flashing: Minor error • Off: Power failure occurred
NS		Green, Red	<p>Indicates the EtherNet/IP network status.</p> <p>■LED color: Green</p> <ul style="list-style-type: none"> • On: Data communications being performed • Flashing: Failed to establish connection • Off: Power failure occurred <p>■LED color: Red</p> <ul style="list-style-type: none"> • Flashing: Connection time out • Off: Power failure occurred
POWER		Green	<p>Indicates the power supply status.</p> <ul style="list-style-type: none"> • On: Power on • Off: Power off or module failure
RUN		Green	<p>Indicates the operating status.</p> <ul style="list-style-type: none"> • On: Normal operation • Off: Error
ERROR		Red	<p>Indicates the module error status.</p> <ul style="list-style-type: none"> • On: Minor error or major error • Flashing: Moderate error or major error • Off: Normal operation
P1	SPEED	Green	<p>Indicates the transmission speed of P1.</p> <ul style="list-style-type: none"> • On: Link-up (100 Mbps) • Off: Link-up (10 Mbps)
	SD/RD	Green	<p>Indicates the data sending/receiving status of P1.</p> <ul style="list-style-type: none"> • On, Flashing: Data being sent or received • Off: Data not transmitted or received
P2	SPEED	Green	<p>Indicates the transmission speed of P2</p> <ul style="list-style-type: none"> • On: Link-up (100 Mbps) • Off: Link-up (10 Mbps)
	SD/RD	Green	<p>Indicates the data sending/receiving status of P2.</p> <ul style="list-style-type: none"> • On, Flashing: Data being sent or received • Off: Data not transmitted or received

3 PROCEDURES BEFORE OPERATION

This chapter describes the procedures before operation.

EtherNet/IP communication

1. Checking the specifications of the FX5-ENET/IP

Check the specifications of the FX5-ENET/IP. (☞ Page 16 SPECIFICATIONS)

2. Installation of the FX5-ENET/IP

Connect the FX5-ENET/IP to the CPU module. For details, refer to the following.

📖 MELSEC iQ-F FX5S/FX5UJ/FX5U/FX5UC User's Manual (Hardware)

3. Configuring a network

Configure a network and set parameters which are required for start-up.

- Wiring (☞ Page 43 WIRING)
- Parameter setting (☞ Page 47 PARAMETER SETTINGS)

4. Network diagnostics

Check the connection status of the connected EtherNet/IP device using EtherNet/IP Configuration Tool for FX5-ENET/IP.

(☞ Page 118 Checking the Network Status)

5. Programming

Create a program. (☞ Page 105 PROGRAMMING)

6. Check the communication status

Check the communication status of FX5-ENET/IP. (☞ Page 111 Checking the Module Status)

General-purpose Ethernet communication

1. Checking the specifications of the FX5-ENET/IP

Check the specifications of the FX5-ENET/IP. (☞ Page 16 SPECIFICATIONS)

2. Installation of the FX5-ENET/IP

Connect the FX5-ENET/IP to the CPU module. For details, refer to the following.

📖 MELSEC iQ-F FX5S/FX5UJ/FX5U/FX5UC User's Manual (Hardware)

3. Configuring a network

Configure a network and set parameters which are required for start-up.

- Wiring (☞ Page 43 WIRING)
- Parameter setting (☞ Page 47 PARAMETER SETTINGS)

In the following steps, refer to the following manual for each function.

📖 MELSEC iQ-F FX5 User's Manual (Ethernet Communication)

📖 MELSEC iQ-F FX5 User's Manual (BACnet)

4 FUNCTION

The following table lists the function available for the FX5-ENET/IP.

4.1 Function List

EtherNet/IP communication functions

Function	Description	Reference
Class1 instance communications	Periodically performs data communications between the FX5-ENET/IP and the EtherNet/IP device to which the connection has been established using an instance ID. Data communications are performed between the originator that sends the connection request and the target that receives the connection request.	Page 25
Class3 message communications	Performs message communications between the FX5-ENET/IP and the EtherNet/IP device to which the connection has been established by specifying a message communication destination using an instance ID. Class3 message communications support the server function.	Page 32
UCMM message communications	Performs message communications between the FX5-ENET/IP and the EtherNet/IP device by specifying a message communication destination using an instance ID without establishing the connection. UCMM message communications support the client function and the server function.	Page 36

General-purpose Ethernet communication functions

For details on general-purpose Ethernet communication functions, refer to the following.

 MELSEC iQ-F FX5 User's Manual (Ethernet Communication)

 MELSEC iQ-F FX5 User's Manual (BACnet)

Function	Description
Direct connection with MELSOFT	FX5-ENET/IP and MELSOFT product (GX Works3, etc.) are connected by single Ethernet cable without using a hub. Communication is done by simply specifying the connection destination; setting the IP address is not required.
MELSOFT connection	Communication with MELSOFT products (GX Works3, etc.) is performed via FX5-ENET/IP.
Connected module search function	Searches for FX5-ENET/IP connected with personal computer using GX Works3 within the same hub. Acquires IP address by selecting from search results list.
MELSOFT diagnosis function	Diagnoses Ethernet port of CPU module and FX5-ENET/IP from GX Works3. (Ethernet diagnostics)
SLMP communication function	Reads and writes PLC data from other device.
Socket communication function	By using socket communication instructions, any data can be transferred from and to the external devices connected through Ethernet using TCP or UDP.
IP filter function	Identifies the IP address of the access source to limit access to the FX5-ENET/IP.
Simple CPU communication function	Allows data communications between specified devices at the specified timing just by doing simple parameter settings from an engineering tool for the FX5-ENET/IP.
IP address change function	The IP address of FX5-ENET/IP can be changed by operating a peripheral device without using GX Works3.
BACnet function	Uses a PLC system as a BACnet device.

Others

Function	Description	Reference
Communication status setting function at the occurrence of a CPU stop error	Sets whether to stop or continue EtherNet/IP communications when a stop error occurs on the CPU module to which the FX5-ENET/IP is connected. This setting can be made for each module.	Page 40
Hardware test	Performs hardware tests (RAM and ROM) of FX5-ENET/IP.	Page 121
Ethernet diagnostics	Diagnoses the Ethernet port from GX Works3.	Page 113
Event history function	Collects errors from FX5-ENET/IP, and stores them as event information into the CPU module	Page 117
Firmware update function	Updates the firmware version of FX5-ENET/IP.	MELSEC iQ-F FX5 User's Manual (Application)

4.2 EtherNet/IP Communication Functions

The EtherNet/IP communication functions are used to perform data communications over a network between the FX5-ENET/IP and EtherNet/IP devices.

The FX5-ENET/IP can perform the following types of EtherNet/IP communications.

- Class1 communications
- Class3 communications
- UCMM communications

Class1 communications

With Class1 communications, data communications are performed periodically by establishing connections between the FX5-ENET/IP and EtherNet/IP devices over a network.

Class1 communications has the following functions.

- Class1 instance communications ( Page 25)

Class3 communications

With Class3 communications, data are read or written using message communication support commands by establishing connections between the FX5-ENET/IP and EtherNet/IP devices over a network.

Class3 communications has the following function.

- Class3 message communications ( Page 32)

UCMM communications

With UCMM communications, message communication support commands are used to read and write data without establishing connections over a network between the FX5-ENET/IP and EtherNet/IP devices.

UCMM communications has the following function.

- UCMM message communications ( Page 36)

Point

FX5-ENET/IP has 32 connections for Class1 communications and 32 connections for Class3 and UCMM communications together. ( Page 17 Performance Specifications)

Applied connection of EtherNet/IP communications

■When the FX5-ENET/IP is the target

○: Requests can be accepted from the EtherNet/IP device, ×: Requests cannot be accepted from EtherNet/IP device, —: No combination

EtherNet/IP communications	Connection settings							
	Connection type	Trigger type			Input type (target to originator)		Output type (originator to target)	
		Cyclic	Application Trigger	Change of State ^{*1}	Fixed ^{*2}	Variable ^{*3}	Fixed ^{*2}	Variable ^{*3}
Class1 instance communications	Exclusive Owner ^{*4}	○	×	×	○	×	○	×
	Input Only ^{*5}	○	×	×	○	×	—	—
	Listen Only ^{*6}	○	×	×	○	×	—	—

*1 A method to send data when the status changes.

*2 A method for communicating with a fixed size.

*3 A method for communicating with a variable size.

*4 A connection simultaneously set from the originator to the FX5-ENET/IP for receiving data and set from the FX5-ENET/IP to the originator for sending data.

*5 A connection set from the FX5-ENET/IP to the originator only for receiving data.

*6 A connection monitored by the originator for data communication with a connection established FX5-ENET/IP.

■When the FX5-ENET/IP is the originator

○: Requests can be accepted from the EtherNet/IP device, ×: Requests cannot be accepted from EtherNet/IP device, —: No combination

EtherNet/IP communications	Connection settings							
	Connection type	Trigger type			Input type (target to originator)		Output type (originator to target)	
		Cyclic	Application Trigger	Change of State ^{*1}	Fixed ^{*2}	Variable ^{*3}	Fixed ^{*2}	Variable ^{*3}
Class1 instance communications	Exclusive Owner ^{*4}	○	○	○	○	○	○	○ ^{*7}
	Input Only ^{*5}	○	○	○	○	○	—	—
	Listen Only ^{*6}	○	○	○	○	○	—	—

*1 A method to send data when the status changes.

*2 A method for communicating with a fixed size.

*3 A method for communicating with a variable size.

*4 A connection simultaneously set from the FX5-ENET/IP to the target for sending data and set from the target to the FX5-ENET/IP for receiving data.

*5 A connection set from the target to the FX5-ENET/IP only for receiving data.

*6 A connection that monitors the data communication with a connection established target

*7 Connection requests can be set, but are sent from the FX5-ENET/IP with a fixed size.



For the connection setting method, refer to the following.

☞ Page 87 [Connections] tab

Class1 instance communications

Function overview

Class1 instance communications is a function for periodically performing data communication between the FX5-ENET/IP and an EtherNet/IP device over a connection that has been established using an instance ID.

Data communications are performed between the originator (the device on the sending side that requests the connection) and the target (the device on the receiving side that is requested to connect).

■When the connection type is Exclusive Owner

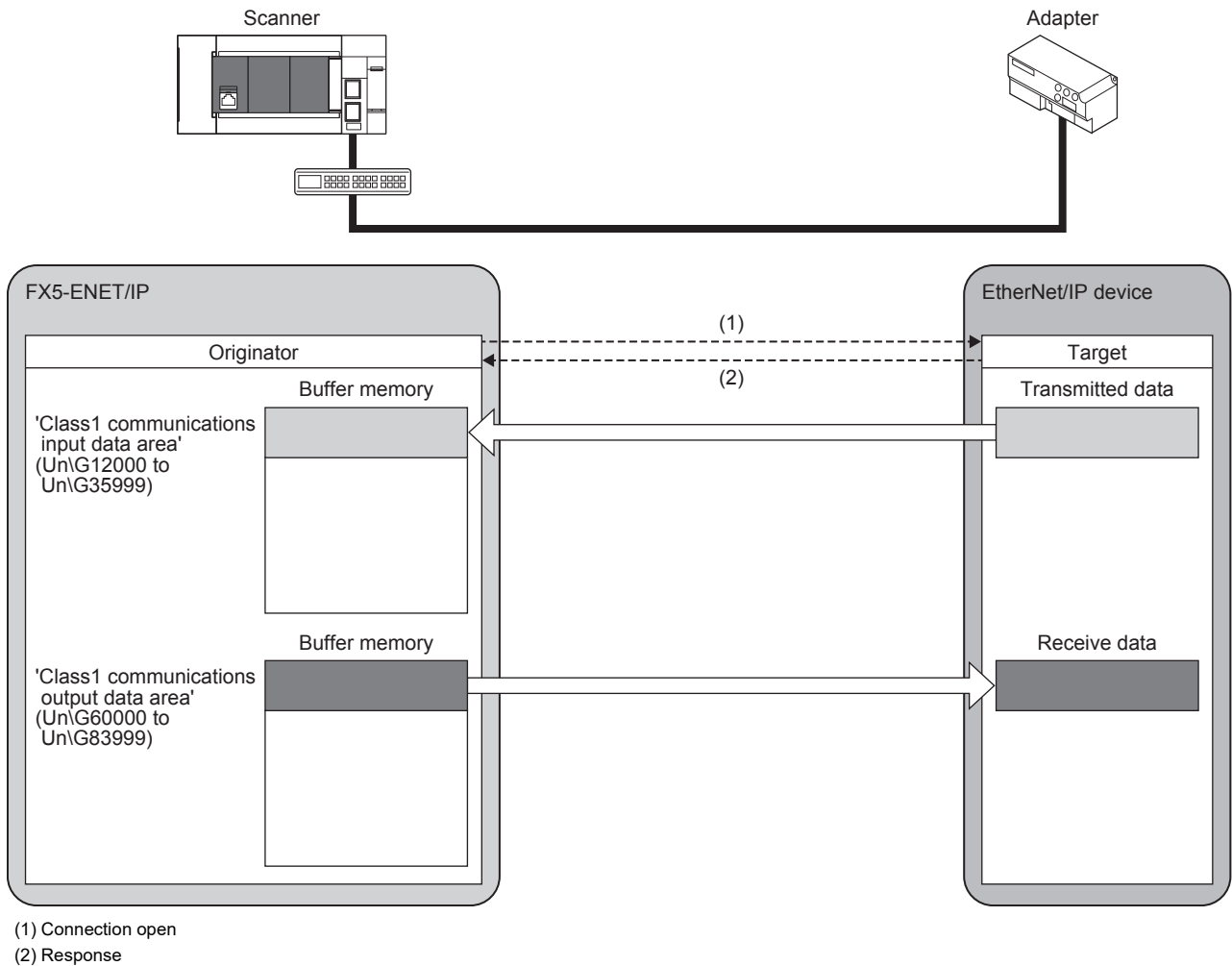

■When the connection type is Input Only

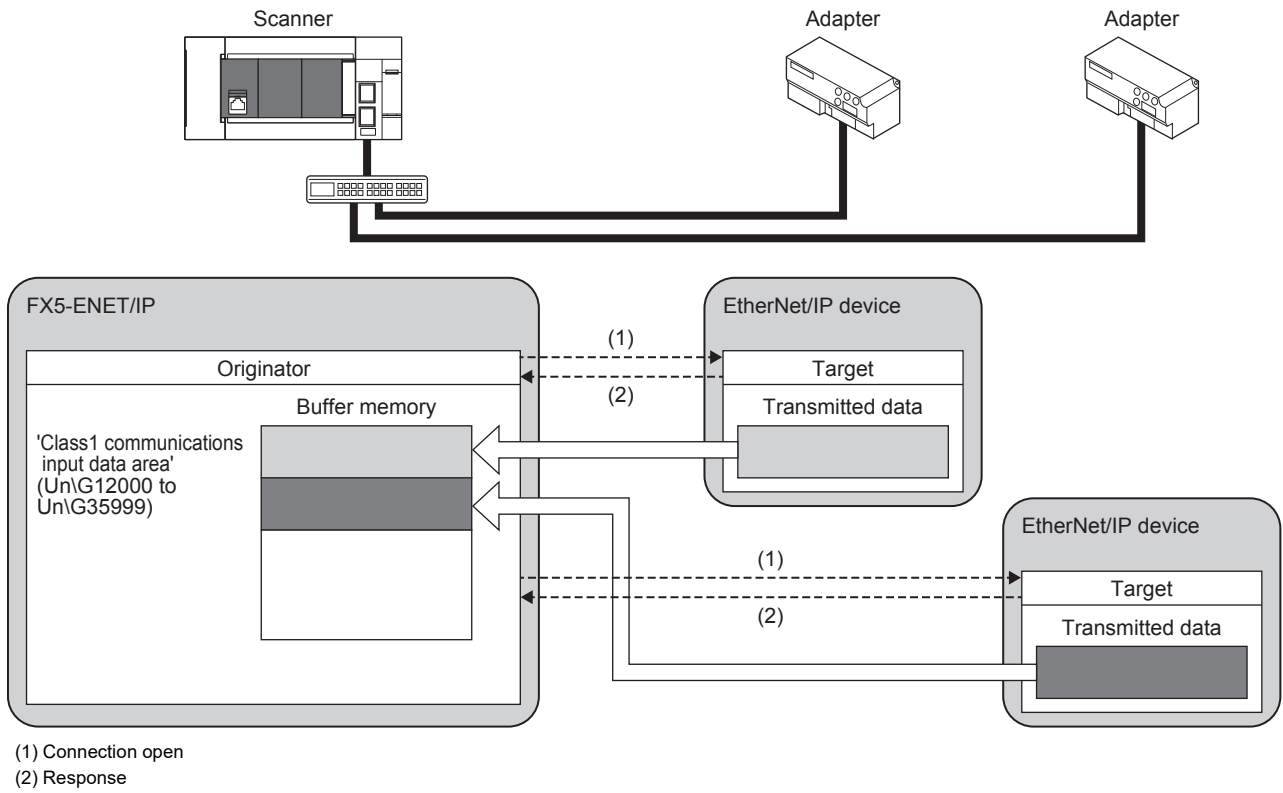

■When the connection type is Listen Only

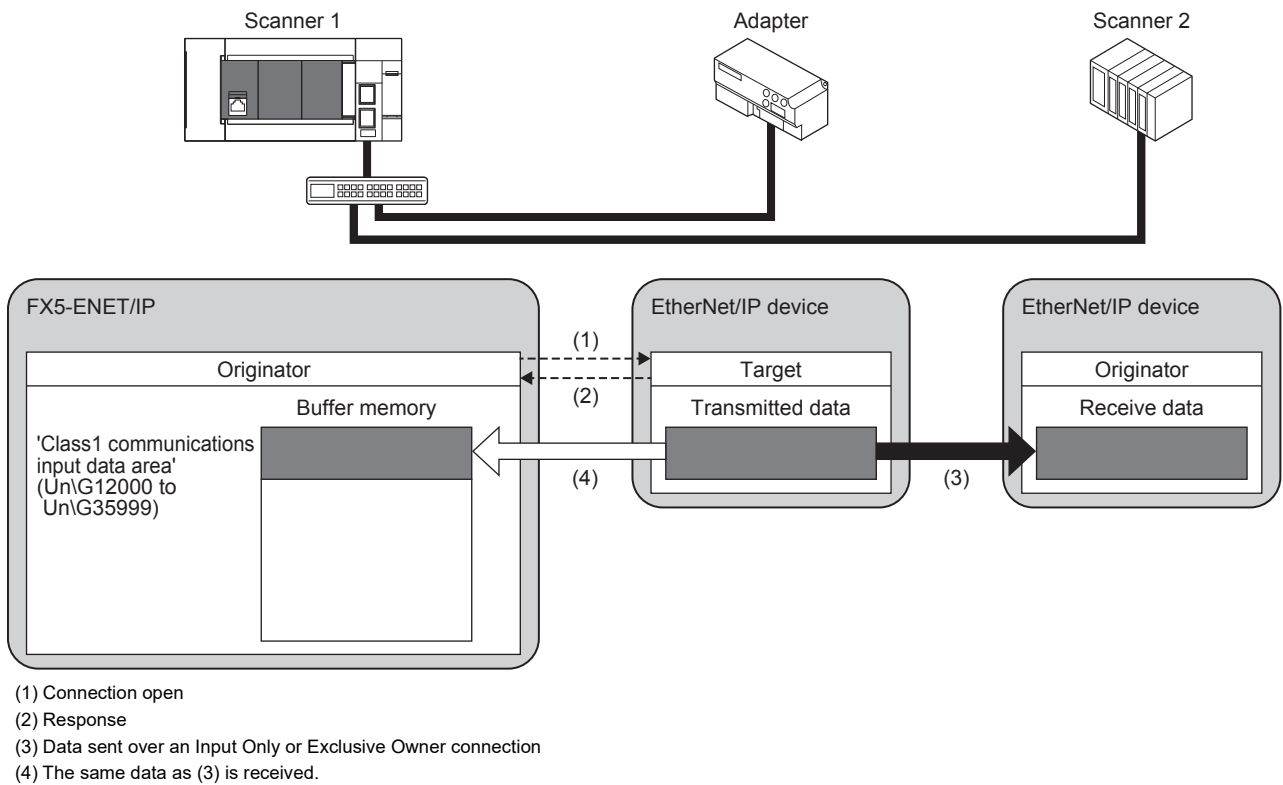

- Listen Only is a connection for the target of which connection such as Exclusive Owner and Input Only that is set for multicast communications is already opened. It can receive only multicast-type data sent to the FX5-ENET/IP.
- The connection of Listen Only cannot be opened when the connection such as Exclusive Owner and Input Only that is set for multicast communications is not opened.
- Even when communications are performed normally with the target that is opened using Listen Only, the data receiving will be stopped if all the communications with other originators that are opened using the connection such as Exclusive Owner and Input Only that is set for multicast communications.

Instance ID

The instance ID is a number that indicates an EtherNet/IP device and is specified when the EtherNet/IP communication connection is established.

With settings from the FX5-ENET/IP, the instance ID is not specified. Instead, the connection number is specified to determine the target.

Communication timing

Class1 instance communications are performed at the RPI interval set with the FX5-ENET/IP on the scanner side.

The RPI can be set for each connection. ( Page 87 [Connections] tab)

The communication trigger type is Cyclic.

Data sending

Data is sent from the originator to the target.

Data can be sent when the connection type is Exclusive Owner.

■ Sending data with the Cyclic trigger type

Data transmission can be repeated periodically.

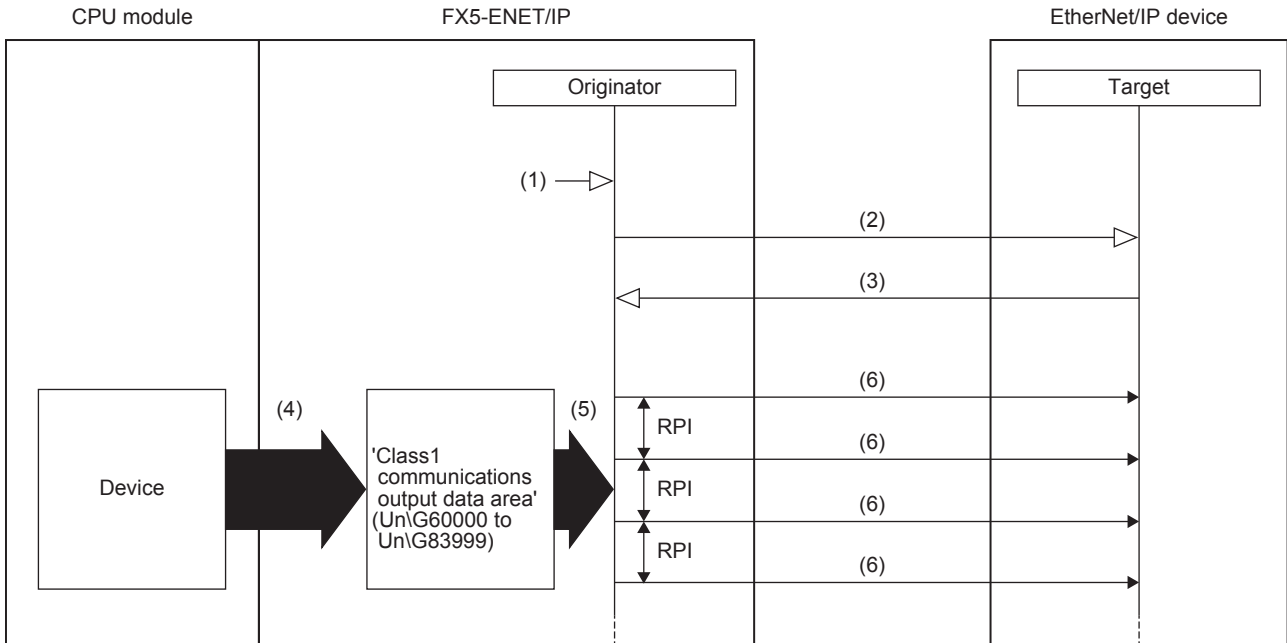

- (1) Turn on 'EtherNet/IP communication start request' (Un\G37.b0)
- (2) Connection open
- (3) Response (normal)
- (4) Transfer the stored data with a program
- (5) Send the stored data at the RPI interval
- (6) Sending data

Data is sent with the Cyclic trigger type according to the following procedure.

1. Connection establishment ((1) to (3) shown above)

The connection is established when 'EtherNet/IP communication start request' (Un\G37.b0) on the FX5-ENET/IP on the scanner side is turned on, the connection open request is sent, and then a response is received from the EtherNet/IP device on the adapter side.

2. Sending data ((5) to (6) shown above)

If the connection is established normally, the originator sends the data stored in 'Class1 communications output data area' (Un\G60000 to Un\G83999).

Point

For the operation timing of EtherNet/IP communications, refer to the following.

☞ Page 150 Operation timing of EtherNet/IP communications

Data receiving

Data is received by the originator from the target.

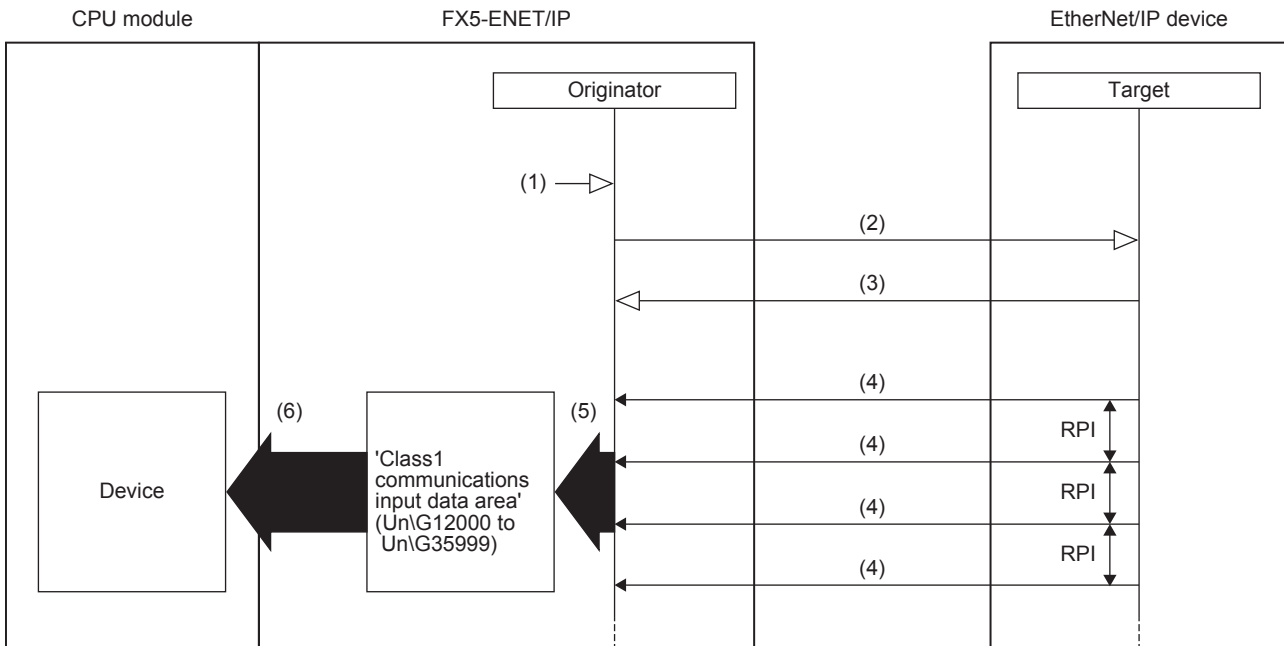

- (1) Turn on 'EtherNet/IP communication start request' (UnG37.b0)
- (2) Connection open
- (3) Response (normal)
- (4) Receiving data
- (5) Store the data received at the RPI interval
- (6) Transfer the stored data with a program

Data is received according to the following procedure.

1. Connection establishment ((1) to (3) shown above)

The connection is established when 'EtherNet/IP communication start request' (UnG37.b0) on the FX5-ENET/IP on the scanner side is turned on, the connection open request is sent, and then a response is received from the EtherNet/IP device on the adapter side.

2. Receiving data ((4) to (5) shown above)

If the connection is established normally, the originator stores the received data in 'Class1 communications input data area' (UnG12000 to UnG35999).



For the operation timing of EtherNet/IP communications, refer to the following.

☞ Page 150 Operation timing of EtherNet/IP communications

Setting method

For Class1 instance communications, set the originator and target on the FX5-ENET/IP on the scanner side.

■Originator (on scanner side) settings

Under "Basic Setting" in the GX Works3, set the IP address, subnet mask, and default gateway of the FX5-ENET/IP.

☞ [Navigation window] ⇒ [Parameter] ⇒ [Module Information] ⇒ [FX5-ENET/IP] ⇒ [Basic Setting]

Item	Setting
Own Node Settings	
IP Address	
IP Address	. . .
Subnet Mask	. . .
Default Gateway	. . .
Opening Method	Do Not Open by Program
Operational Setting	
External Device Configuration	

For details on the setting window, refer to the following.

☞ Page 48 Basic Setting

■Target (on adapter side) settings

After registering the EtherNet/IP device with EtherNet/IP Configuration Tool for FX5-ENET/IP, set the adapter side for each connection.

For details on registering EtherNet/IP devices, refer to the following.

☞ Page 100 Procedure for Registering EtherNet/IP Devices

☞ Select the EtherNet/IP device in the network configuration settings ⇒ [Device] ⇒ [Properties] ⇒ [Connections] tab

The screenshot shows the 'In-Sight 5000 Series Revision 3.40' window with the 'Connections' tab selected. On the left, a tree view shows 'IS5XXX Revision 3.40' expanded to 'Produce Data To', with sub-items for 'General', 'Check Device Identity', and 'Configuration Setting'. On the right, the 'Connections Parameters' table is displayed:

Name	Value	Unit
Connection No.	1	
Time-out Multiplier	x4	
Input - T->O		
Input Size	0	bytes
Input Mode	Point to Point	
Input Type	Fixed	
Priority	Scheduled	
Trigger Type	Cyclic	
Request Packet Interval (RPI)	30	ms
Output - O->T		
Output Size	8	bytes
Output Mode	Point to Point	
Output Type	Fixed	
Priority	Scheduled	
Request Packet Interval (RPI)	100	ms

(1) Input data size

(2) Trigger type

(3) RPI

(4) Output data size

(5) RPI

For details on the setting window, refer to the following.

☞ Page 87 [Connections] tab

Assurance of input/output data

The data received from EtherNet/IP devices and the data transmitted to EtherNet/IP devices can be assured for each connection. The data assurance is enabled by setting the buffer memory and acquiring the input data and setting the output data using the following module FBs.

- Class1 communication input data acquisition (Class1GetInputData)
- Class1 communication output data setting (Class1SetOutputData)

■ Procedure

1. Write "16: Perform data assurance" in 'Block assurance specification per connection' (Un\G5000) while the module is not communicating with the EtherNet/IP communication device.
2. Turn on 'EtherNet/IP communication start request' (Un\G37.b0) to start the communications with the EtherNet/IP communication device.
3. Acquire the received data and set the transmitted data using the unit FBs "Class1 communication input data acquisition" and "Class1 communication output data setting" on the program.

Class3 message communications

Function overview

Class3 message communications is a function for performing message communications between the FX5-ENET/IP and an EtherNet/IP device over a connection that has been established by specifying the message communication destination with an instance ID.

Class3 message communication supports the server functions.

■Server function

With the server function, message communication support commands are used to communicate with arbitrary timing.

(☞ Page 33 Server function)

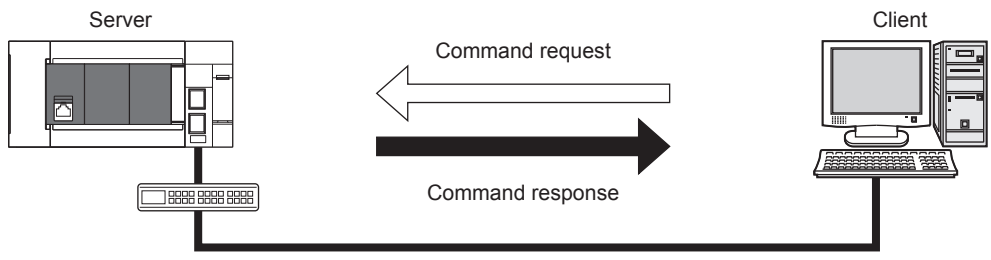

Message communication support commands

Items such as data and parameters can be read and written with message communication support commands.

For details on message communication support command objects, refer to the following.

(☞ Page 166 Details of Message Communication Support Command)

Server function

With the Class3 message communication server function, when the FX5-ENET/IP receives a command request from an EtherNet/IP device, the FX5-ENET/IP executes the command processing and returns the command response.

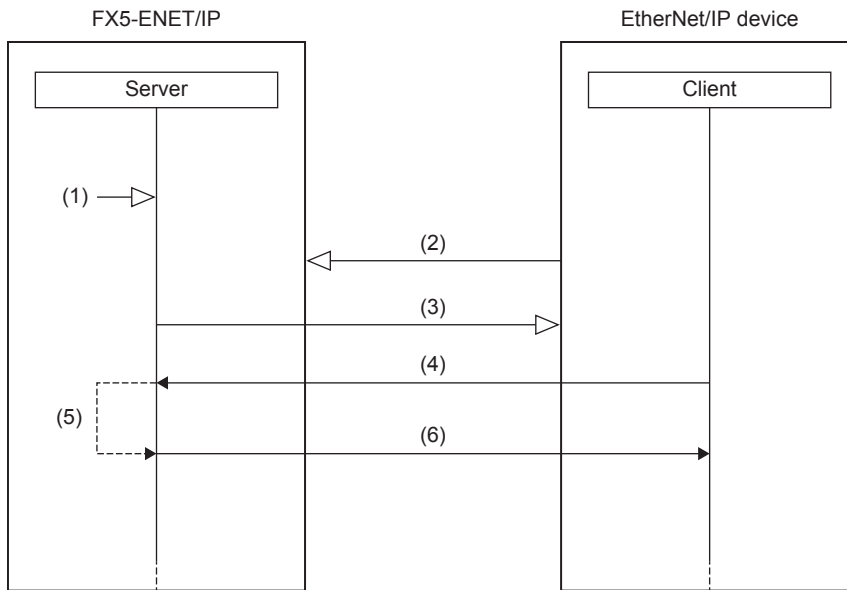

- (1) Turn on 'EtherNet/IP communication start request' (Un\G37.b0)
- (2) Connection open
- (3) Response (normal)
- (4) Command request
- (5) Command processing execution
- (6) Command response

Class3 message communications with the server function is performed according to the following procedure.

1. Connection establishment ((1) to (3) shown above)

The connection is established when 'EtherNet/IP communication start request' (Un\G37.b0) of the FX5-ENET/IP on the server side is turned on, a connection open request is received from the EtherNet/IP device on the client side, and then a response is returned.

2. Command request acceptance and response ((4) to (6) shown above)

If the connection is established normally, a command request is sent from the EtherNet/IP device with arbitrary timing. When the FX5-ENET/IP receives the command request from the EtherNet/IP device, the FX5-ENET/IP executes the command processing and returns the command response to the EtherNet/IP device.



For the operation timing of EtherNet/IP communications, refer to the following.

Page 150 Operation timing of EtherNet/IP communications

Setting method

Set the server for the FX5-ENET/IP that performs Class3 message communications.

Under "Basic Setting" in the GX Works3, set the IP address, subnet mask, and default gateway of the FX5-ENET/IP.

 [Navigation window] ⇒ [Parameter] ⇒ [Module Information] ⇒ [FX5-ENET/IP] ⇒ [Basic Setting]

Item	Setting
Own Node Settings	
IP Address	
IP Address	. . .
Subnet Mask	. . .
Default Gateway	. . .
Opening Method	Do Not Open by Program
Operational Setting	
External Device Configuration	

For details on the setting window, refer to the following.

 Page 48 Basic Setting

Communication method

Open the connection from the client side, and execute the command request.

When the server receives the command request, it returns the command response to the client side.

To request commands using EtherNet/IP Configuration Tool for FX5-ENET/IP, use the "Online Action" window.

1. Start EtherNet/IP Configuration Tool for FX5-ENET/IP, and set the IP address on the server side.

 Select the "FX5-ENET/IP" in the EtherNet/IP setting ⇒ [Description] ⇒ [Properties]

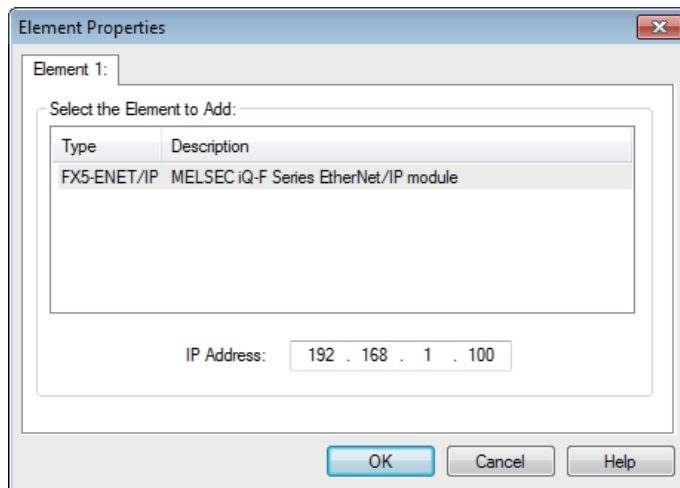

2. Switch EtherNet/IP Configuration Tool for FX5-ENET/IP to the online state.

 Select the EtherNet/IP device in the network configuration settings ⇒ [File] ⇒ [Go Online]

3. Execute the command request of Class3 message communications in the "Online Action" window.

[Network]⇒[Online Action]

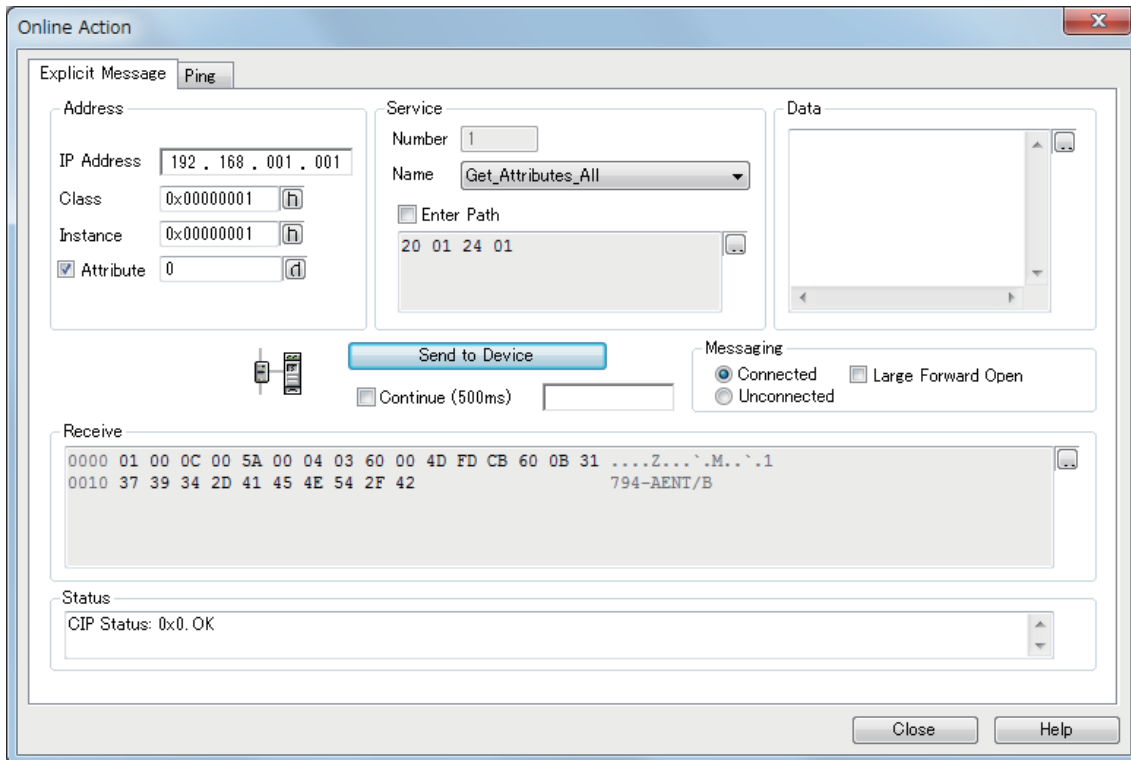

For details on the setting window, refer to the following.

Page 71 "Online Action" window

Point

Commands for message communications can be requested from software made by other companies. When requesting commands from software made by other companies, refer to the manual of the software used.

UCMM message communications

Function overview

UCMM message communications is a function for performing message communications between the FX5-ENET/IP and an EtherNet/IP device by specifying the message communication destination with an instance ID and not by establishing a connection.

UCMM message communication supports the client and server functions.

Client function

With the client function, the buffer memory is used to communicate with arbitrary timing. (☞ Page 37 Client function)

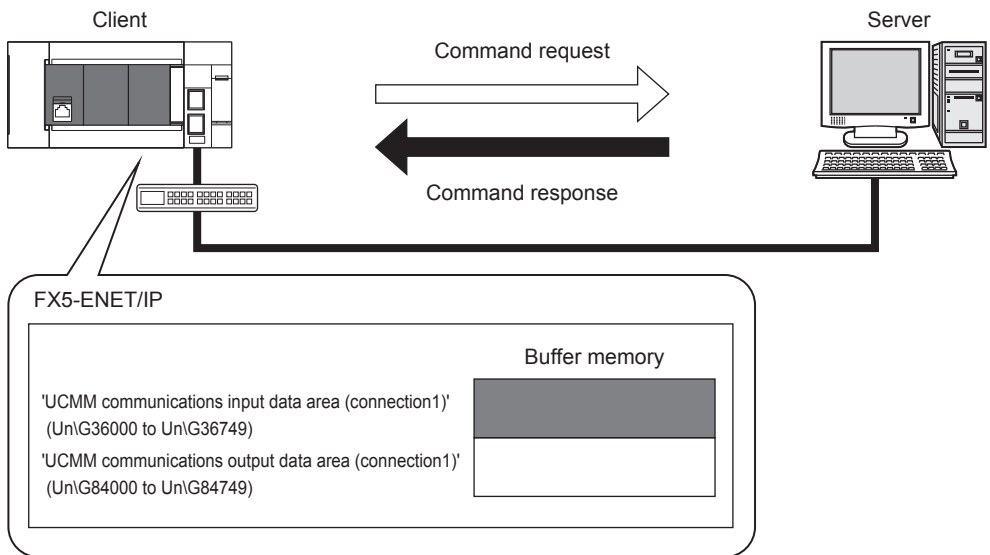

Server function

With the server function, message communication support commands are used to communicate with arbitrary timing.

(☞ Page 38 Server function)

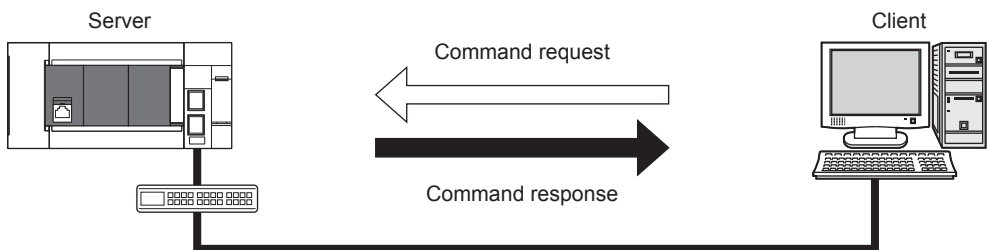

Message communication support commands

Items such as data and parameters can be read and written with message communication support commands.

For details on message communication support command objects, refer to the following.

☞ Page 166 Details of Message Communication Support Command

Client function

With the UCMM message communication client function, the buffer memory of the FX5-ENET/IP is used to send command requests to and receive command responses from the EtherNet/IP device.

The client function can be used to access the services of each EtherNet/IP device and thereby read and write items such as the data and parameters with arbitrary timing.

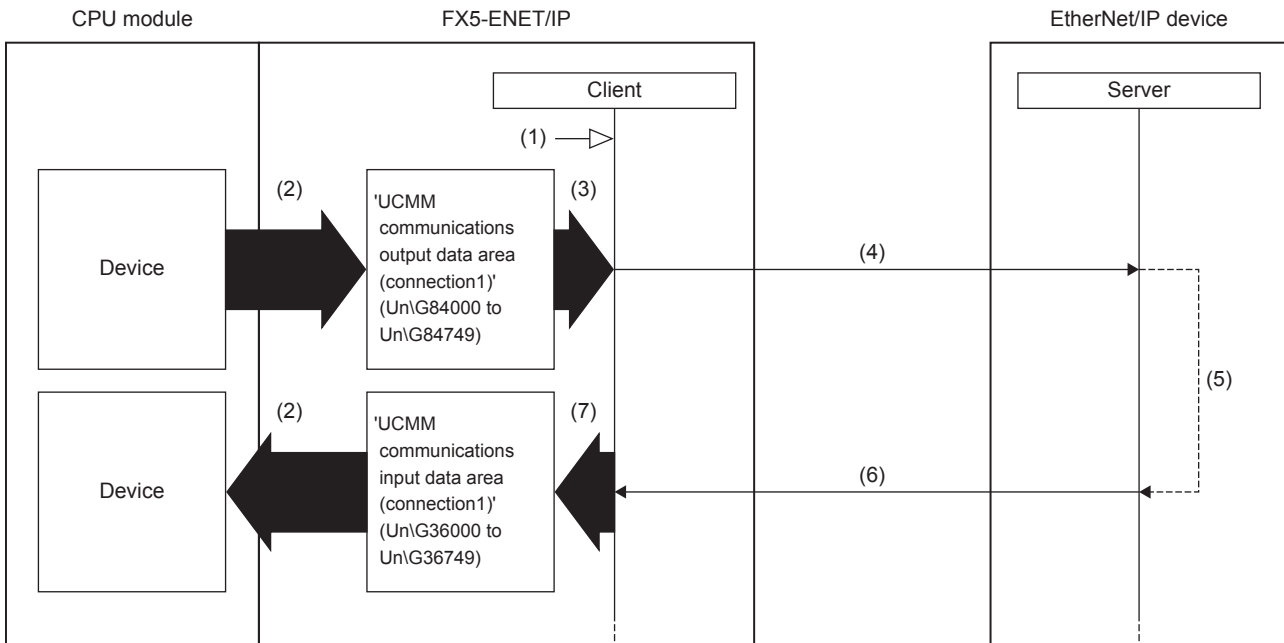

- (1) Turn on 'EtherNet/IP communication start request' (Un\G37.b0)
- (2) Transfer the stored data with a program
- (3) Turn on 'Application Trigger request' (Un\G5274 to Un\G5275)
- (4) Command request
- (5) Command processing execution
- (6) Command response
- (7) Turn on 'Application Trigger completion' (Un\G5282 to Un\G5283)

UCMM message communications with the client function is performed according to the following procedure.

1. Starting the UCMM communication execution request ((1) to (3) shown above)

Turn on 'EtherNet/IP communication start request' (Un\G37.b0) and then turn on 'Application Trigger request' (Un\G5274 to Un\G5275) from the FX5-ENET/IP on the client side.

2. Sending the command request ((4) shown above)

When the FX5-ENET/IP checks the UCMM data link execution request, 'Application Trigger acceptance' (Un\G5278 to Un\G5279) is turned on, and then the command request is sent to the EtherNet/IP device.

3. Command response acceptance ((5) to (6) shown above)

The EtherNet/IP device executes the command processing, and then returns the command response.

When the FX5-ENET/IP receives the command response from the EtherNet/IP device, the FX5-ENET/IP turns on 'Application Trigger completion' (Un\G5282 to Un\G5283) to complete the processing.

Point

For the operation timing of EtherNet/IP communications, refer to the following.

☞ Page 161 Application Trigger

Server function

With the UCMM message communication server function, when the FX5-ENET/IP receives a command request from an EtherNet/IP device, the FX5-ENET/IP executes the command processing and returns the command response.

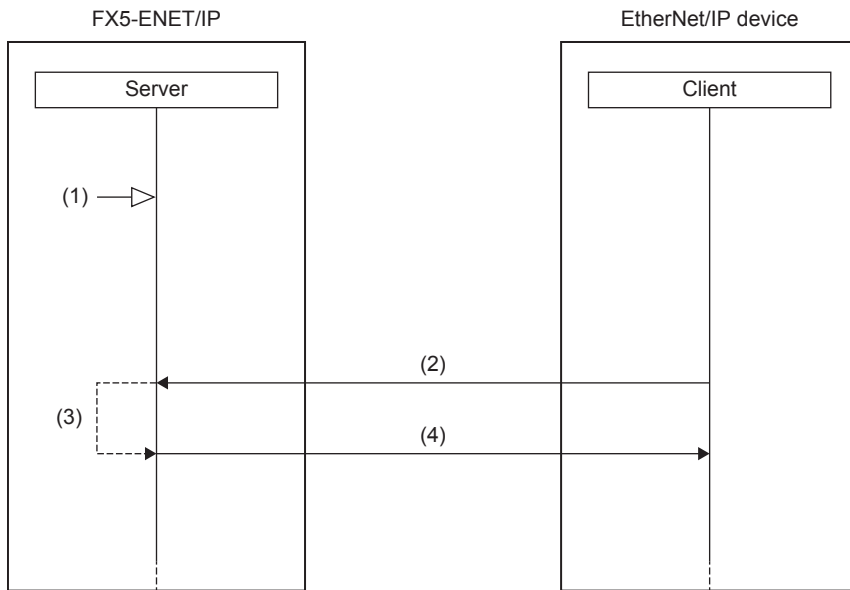

- (1) Turn on 'EtherNet/IP communication start request' (Un\G37.b0)
- (2) Command request
- (3) Command processing execution
- (4) Command response

UCMM message communications with the server function is performed according to the following procedure.

1. Starting the EtherNet/IP communication start request ((1) shown above)

Turn on 'EtherNet/IP communication start request' (Un\G37.b0) from the FX5-ENET/IP on the server side.

2. Command request acceptance and response ((2) to (4) shown above)

When the FX5-ENET/IP receives the command request from the EtherNet/IP device with arbitrary timing, the FX5-ENET/IP executes the command processing and returns the command response to the EtherNet/IP device.

Point

For the operation timing of EtherNet/IP communications, refer to the following.

☞ Page 150 Operation timing of EtherNet/IP communications

Setting method

Set the server and the client for the FX5-ENET/IP that performs UCMM message communications.

Under "Basic Setting" in the GX Works3, set the IP address, subnet mask, and default gateway of the FX5-ENET/IP.

☞ [Navigation window] ⇒ [Parameter] ⇒ [Module Information] ⇒ [FX5-ENET/IP] ⇒ [Basic Setting]

Item	Setting
Own Node Settings	
IP Address	
IP Address
Subnet Mask
Default Gateway
Opening Method	Do Not Open by Program
Operational Setting	
External Device Configuration	

For details on the setting window, refer to the following.

☞ Page 48 Basic Setting

Communication method

■When the client function is used

Execute a command request from the FX5-ENET/IP by operating a program that uses the buffer memory.

For program example of UCMM message communications, refer to the following.

☞ Page 107 Program Example of UCMM Message Communications

■When the server function is used

Open the connection from the client side, and execute the command request.

When the server receives the command request, it returns the command response to the client side.

To request commands using EtherNet/IP Configuration Tool for FX5-ENET/IP, use the "Online Action" window.

For communication method, refer to the following.

☞ Page 34 Communication method

For UCMM message communications, set "Messaging" to "Unconnected" in the "Online Action" window.

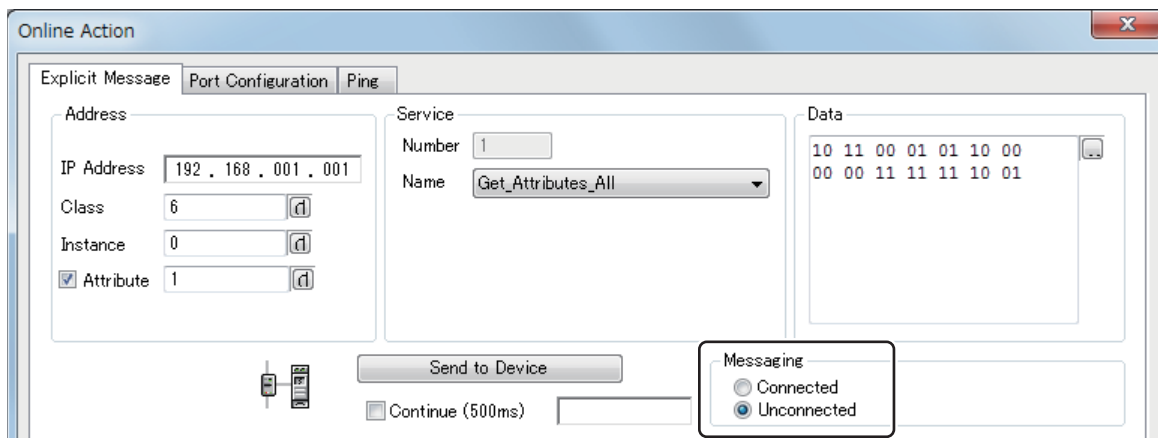

With message communications, commands can also be requested from software made by other companies. When requesting commands from software made by other companies, refer to the manual of the software used.

Communication Status Setting Function When a CPU Stop Error Occurs

Each FX5-ENET/IP can be set to stop or continue EtherNet/IP communications when a stop error occurs on the CPU module which the FX5-ENET/IP is mounted on.

Therefore, EtherNet/IP communications can be continued even when the stop error occurring CPU module goes into the STOP state.

Procedure

1. Write "16: Continues EtherNet/IP communications" in 'EtherNet/IP data link continuation specification' (Un\G5004) while the module is not communicating with the EtherNet/IP communication device.
2. Turn on 'EtherNet/IP communication start request' (Un\G37.b0) to start the communications with the EtherNet/IP communication device.

Operation of EtherNet/IP communications

When a CPU stop error occurs, the EtherNet/IP communications are made by the communication status setting function as shown below.

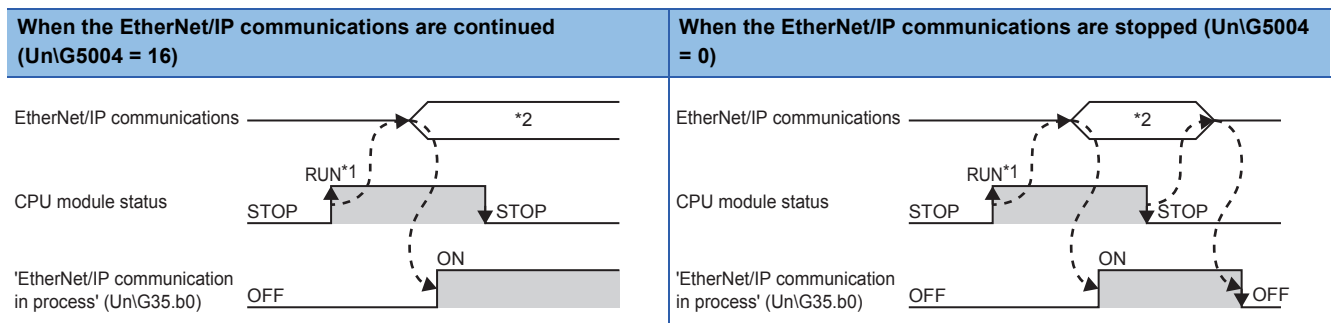

*1 When the CPU module starts running after it stops, the EtherNet/IP communications will start.

*2 Communication enabled

5 SYSTEM CONFIGURATION

5.1 EtherNet/IP Configuration

Network topology

EtherNet/IP consists of the FX5-ENET/IP (1) and EtherNet/IP devices (2).

For the FX5-ENET/IP, configure the network in star topology, or line topology using the Ethernet cables. Ring topologies are not possible.

■Star topology

The network is configured into a star shape using a switching hub and Ethernet cables.

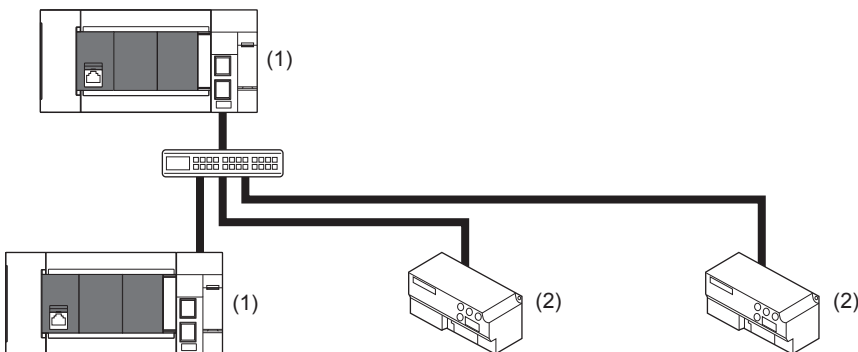

■Line topology

The network is configured into a line using Ethernet cables. A switching hub is not required.

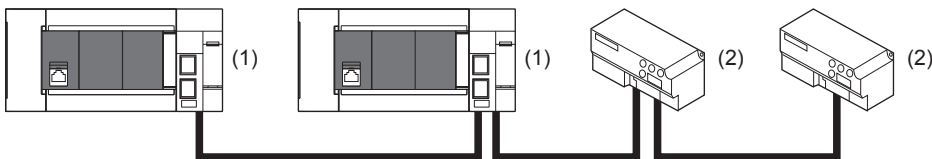

Point

- In EtherNet/IP, other external devices that perform TCP/IP communications can be used with the devices on the same network.
- Up to 33 units can be connected in line topology.

Scanner and adapter

In EtherNet/IP, station types are separated into scanner and adapter.

Station type	Description
Scanner	A station type of EtherNet/IP that corresponds to the master station. The scanner has the control information and controls the overall network. Devices that have a connection of originator or target can be operated as the scanner.
Adapter	A station type of EtherNet/IP that corresponds to slave stations. The adapter indicates stations other than the scanner. Devices that have a connection of target can be operated as the adapter.

5.2 General-purpose Ethernet Communication Configuration

For details on general-purpose Ethernet communication configuration, refer to  MELSEC iQ-F FX5 User's Manual (Ethernet Communication).

5.3 Available Software Packages

To configure the settings of the FX5-ENET/IP, the GX Works3 and EtherNet/IP Configuration Tool for FX5-ENET/IP are required.

Software	Supported version
GX Works3	Ver.1.050C or later
EtherNet/IP Configuration Tool for FX5-ENET/IP	Ver.1.00A or later

EtherNet/IP Configuration Tool for FX5-ENET/IP

Contact your local Mitsubishi Electric representative for information on how to obtain the EtherNet/IP Configuration Tool for FX5-ENET/IP.

■Operating environment, installation and uninstallation

For the operating environment and installation/uninstallation of EtherNet/IP Configuration Tool for FX5-ENET/IP, refer to the following.

EtherNet/IP Configuration Tool for FX5-ENET/IP Installation Instructions

■Operation methods and functions

For operation methods and functions of EtherNet/IP Configuration Tool for FX5-ENET/IP, refer to the following.

 Page 57 EtherNet/IP Configuration Tool for FX5-ENET/IP

■EDS file

Please download the EDS file from Mitsubishi Electric FA Global Site.

www.MitsubishiElectric.com/fa

6 WIRING

6.1 Grounding

Perform the following.

- Perform class D grounding (Grounding resistance: 100 Ω or less).
- Ground the PLC independently when possible.
- If the PLC cannot be grounded independently, perform the "Shared grounding" shown below.

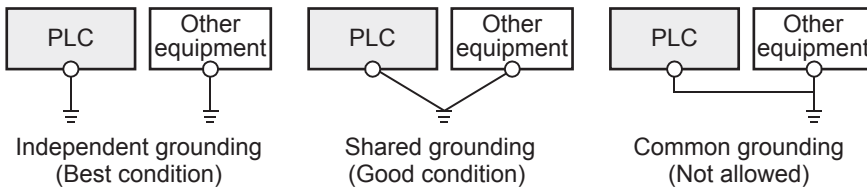

- Bring the grounding point close to the PLC as much as possible so that the ground cable can be shortened.

Grounding of FX5-ENET/IP

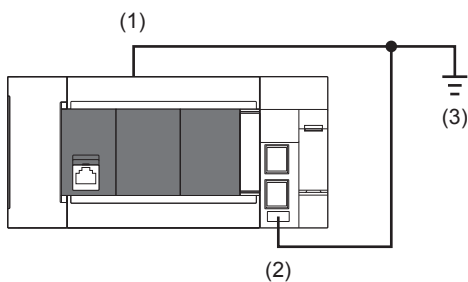

- (1) Ground terminal of CPU module
 (2) FG terminal of FX5-ENET/IP
 (3) D grounding (Grounding resistance: 100 Ω or less)

Terminal name	Content
⏏ FG (Ground terminal)	Perform class D grounding. (Grounding resistance: 100 Ω or less)

The connection destination for the FG terminal of FX5-ENET/IP is a spring clamp terminal block.

To connect to the terminal block, there are two ways: by using single wires/strand wires or by using ferrules. Make sure to properly connect in accordance with the following specifications.

■ Ferrule

The following table shows wire ferrules and its associated tools compatible with the terminal block. The shape of the wire ferrule differs depending on the crimp tool to be used, use the reference product. If the product other than referenced products is used, the wire ferrule cannot be removed. Sufficiently confirm that the wire ferrule can be removed before use.

<Reference product>

Manufacturer	Sleeve	Ferrules model	Suitable wiring size	Crimp tool
PHOENIX CONTACT GmbH & Co. KG	Ferrules with insulation sleeve	AI 0.25-8 YE	0.25 mm ²	CRIMPFOX 6
		AI 0.34-8 TQ	0.3, 0.34 mm ²	
		AI 0.5-8 WH	0.5 mm ²	
		AI 0.75-8 GY	0.75 mm ²	
	Ferrules without insulation sleeve	A 0,25-7	0.25 mm ²	
		A 0,34-7	0.3, 0.34 mm ²	
		A 0,5-8	0.5 mm ²	
		A 0,75-8	0.75 mm ²	
		AI 1.0-8	1.0 mm ²	
		AI 1.5-7	1.25, 1.5 mm ²	

The wires to connect the spring clamp terminal block are described below.

No. of wire per terminal	Wire size	
	Single wire, strand wire	Ferrule with insulation sleeve
One wiring	AWG24 to 16 (0.2 to 1.5 mm ²)	AWG23 to 19 (0.25 to 0.75 mm ²)

■Wire end treatment

Strip the cable about 10 mm from the tip to connect a wire ferrule at the stripped area. Failure to do so may result in electric shock due to the conductive part. If the wire strip length is too short, it may result in the poor contact to the spring clamp terminal part.

Depending on the thickness of the sheath, it may be difficult to insert into the insulation sleeve, so select the wires by referring to the appearance diagram.

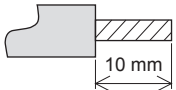
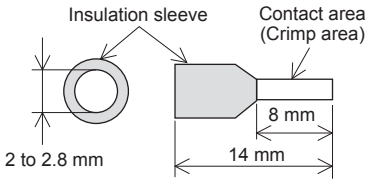
Strand wire/single wire	Ferrule with insulation sleeve
	

Check the shape of the wire insertion opening with the following chart, and use the smaller wire ferrule than the described size. Also, insert the wire with care so that the wire ferrule is in proper orientation. Failure to do so may cause the bite of the terminal and the damage of the terminal block.

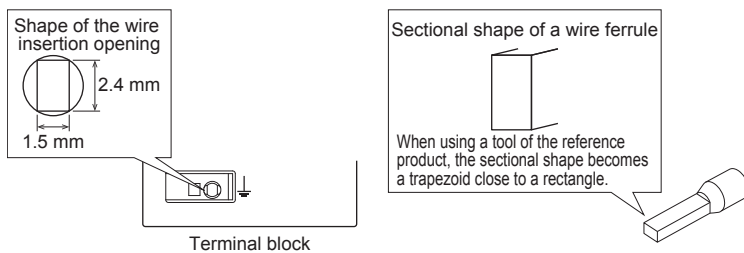

■Connection and disconnection of the cable

- Connection of the cable

Fully insert a cable whose end has been properly processed into the wire insertion opening.

If the cable cannot be inserted with this procedure, fully insert the cable while pushing the open/close button with a flathead screwdriver having a tip width of 2.0 to 2.5 mm. After fully inserting the cable, remove the screwdriver.

<Reference>

Manufacturer	Model
PHOENIX-CONTACT GmbH & Co. KG	SZS 0.4 × 2.5 VDE

Precautions

Pull the cable or wire ferrule slightly to check that the cable is securely clamped.

- Disconnection of the cable

Push the open/close button of the wire to be disconnected with a flathead screwdriver. Pull out the wire with the open/close button pushed.

6.2 Wiring Method

This section describes how to connect and disconnect the Ethernet cable.

Connecting the cable

1. Turn the power supply of FX5-ENET/IP (CPU module) and external device off.
2. Push the Ethernet cable connector into the FX5-ENET/IP until it clicks. Pay attention to the orientation of the connector.
3. Lightly pull the connector to check that the connector is securely connected.
4. Turn the power supply of FX5-ENET/IP (CPU module) and external device on.
5. Check whether the SPEED LED of the port connected with an Ethernet cable is on.*¹

*¹ The time between the cable connection and the turning on of the SPEED LED may vary. The SPEED LED usually turns after a few seconds. Note, however, that the time may be extended further if the link-up processing is repeated depending on the status of the device on the line.

Disconnecting the cable

1. Turn the power supply of FX5-ENET/IP (CPU module) off.
2. Unplug the Ethernet cable while pressing the latch connector down.

Precautions

- Place the Ethernet cable in a duct or clamp it. If the cable is not placed in a duct or secured with clamps, the cable may swing, drag or be carelessly pulled, and the module or cable may be damaged, or cable contact failure may cause malfunction.
- Do not touch the core of the cable-side or module-side connector, and protect them from dirt or dust. If oil on your hands, dirt, or dust adheres to the core, transmission loss may increase, causing communication problems.
- Check that the Ethernet cable is not disconnected or not shorted and check that the cable is connected properly.
- Do not use Ethernet cables with broken latch connectors. Doing so may cause the Ethernet cables to be disconnected or the module to malfunction.
- Hold the connector part of the Ethernet cable when connecting and disconnecting it. Pulling the cable connected to the module may result in damage to the module or the cable or malfunction due to poor contact.
- For connectors without Ethernet cable, attached connector cover should be placed to prevent foreign matter such as dirt or dust.
- The maximum station-to-station distance of the Ethernet cable is 100 m. However, the acceptable length may be shorter depending on the environment where the cable is used. For details, contact the cable manufacturer.
- The bending radius of the Ethernet cable is limited. For details, check the specifications of the Ethernet cable to be used.

6.3 Wiring Products

This section describes the devices used to comprise a network.

Ethernet cable

Use Ethernet cables that meet the following standards.

■EtherNet/IP

Communication speed	Specifications	Connector	Ethernet standard
100 Mbps	Ethernet cable: Category 5 or higher (STP cable ^{*1})	RJ45 connector	100BASE-TX

■General-purpose Ethernet

Communication speed	Specifications	Connector	Ethernet standard
100 Mbps	Ethernet cable: Category 5 or higher (STP cable ^{*1})	RJ45 connector	100BASE-TX
10 Mbps	Ethernet cable: Category 3 or higher (STP/UTP cable ^{*1})	RJ45 connector	10BASE-T

^{*1} Shielded twisted pair cable.
A straight/cross cable can be used.

Point

Depending on the connection environment, communication errors may occur due to high-frequency noise from devices other than programmable controllers. The following describes precautionary measures to be taken on the FX5-ENET/IP to avoid the influence of high-frequency noise.

[Wiring]

- When wiring cables, do not bundle them together with or keep them in close proximity to the main circuit lines or power cables.
- Place cables in a duct.
- Use STP cables in place of UTP cables.

Hub

When using hubs, use hubs that support the transmission speed of communications.

7 PARAMETER SETTINGS

This section explains the parameter settings necessary for EtherNet/IP and general-purpose Ethernet communications with FX5-ENET/IP.

For details on each operation of GX Works3, refer to  GX Works3 Operating Manual.

7.1 Procedure for Setting Parameters

1. Add the "Information Module (FX5-ENET/IP)" in the GX Works3.^{*1}

 [Navigation window] ⇒ [Parameter] ⇒ [Module Information] ⇒ Right-click ⇒ [Add New Module]

2. Select the "FX5-ENET/IP".

 [Navigation window] ⇒ [Parameter] ⇒ [Module Information] ⇒ [FX5-ENET/IP]

3. Set the parameter.

4. Write the parameter settings to the CPU module.

 [Online] ⇒ [Write to PLC]

5. The settings are reflected by resetting the CPU module or powering off and on the system.

The following steps are required when EtherNet/IP is used.

6. Connect the personal computer and FX5-ENET/IP, and start EtherNet/IP Configuration Tool for FX5-ENET/IP.

7. Set the communication parameter of EtherNet/IP. ( Page 57 EtherNet/IP Configuration Tool for FX5-ENET/IP)

8. Write the parameter settings to the FX5-ENET/IP. ( Page 56 Writing Parameters)

^{*1} FX5-ENET/IP can be added to GX Works3 also from the module configuration diagram.

7.2 Required Settings

Set the operation mode of the FX5-ENET/IP.

Mode

Set the operation mode of the FX5-ENET/IP.

Item	Description	Setting range
Communication Mode	Sets the operation mode of the FX5-ENET/IP. <ul style="list-style-type: none"> • Online: Normal operation mode • Hardware test: Mode in which the module performs a self-diagnostics test. Select this mode when checking the operation of the module due to an error or similar problem. (Page 121 Hardware Test) 	<ul style="list-style-type: none"> • Online • Hardware Test (Default: Online)

Restriction

In the hardware test mode, other parameters cannot be set.

7.3 Basic Setting

Set the IP address and functions of FX5-ENET/IP.

Own Node Setting

Set the IP address of the FX5-ENET/IP.

Item		Description	Setting range
IP Address Setting	IP Address	Sets the IP address of the FX5-ENET/IP* ¹ Set the class and subnet address of the FX5-ENET/IP to the same settings as those of the EtherNet/IP devices that communicate with the FX5-ENET/IP. Contact the network administrator before setting the IP address.	<ul style="list-style-type: none"> Blank 0.0.0.1 to 223.255.255.254 (Default: Blank)
	Subnet Mask	Sets the subnet mask of the FX5-ENET/IP. When setting the IP address of the default gateway and performing communication with an EtherNet/IP device in another network through a router, set the subnet mask pattern of the default gateway. All the devices in the same subnet network should have a common subnet mask. The subnet mask setting is not required for communication in a single network.	<ul style="list-style-type: none"> Blank 0.0.0.1 to 255.255.255.255 (Default: Blank)
	Default Gateway	Sets the default gateway of the FX5-ENET/IP. Set the IP address of the relay device (default gateway) to access the EtherNet/IP device in another network. Set a value that satisfies the following conditions as the IP address of the default gateway. <ul style="list-style-type: none"> The class of the IP address is A, B, or C. The subnet address of the default gateway is the same as that of the FX5-ENET/IP. The host address part is not a sequence of "0" or "1". 	<ul style="list-style-type: none"> Blank 0.0.0.1 to 223.255.255.254 (Default: Blank)
Communication Data Code		Select the format of the data to be used for communication. <ul style="list-style-type: none"> Binary: communicating data in binary code ASCII (X, Y octal): Communicating in ASCII code (X, Y octal) ASCII (X, Y hexadecimal): Communicating in ASCII code (X, Y hexadecimal) 	<ul style="list-style-type: none"> Binary ASCII (X, Y octal) ASCII (X, Y hexadecimal) (Default: Binary)
Opening Method		Select how to open a connection. <ul style="list-style-type: none"> Do Not Open by Program: Select this item to perform open processing and open the connection by the external device. Program for open/close processing is not required. Open by Program: Select this item to perform open/close processing and open/close the connection by a program. 	<ul style="list-style-type: none"> Do Not Open by Program Open by Program (Default: Do Not Open by Program)

*1 When the parameter is written without the IP address setting (blank), the following address is set.
192.168.3.251

Operational Setting

Set the destination alive check conditions for socket communication.

Item		Description	Setting range
Timer Settings for Data Communication	Change/Set Timer Value	Select whether to change timer values from the default. The timer operates with its default value when "No" is selected.	<ul style="list-style-type: none"> No Yes (Default: No)
	Destination Alive Check Start Interval Timer	Set the time interval between the reception of the last message from the external device and the start of alive check.	<ul style="list-style-type: none"> Unit [s]: 1 to 16383 Unit [ms]: 100 to 16383000 (Default: 600 s)
	Destination Alive Check Interval Timer	Set the time interval for performing alive check again when no response is returned from the external device of alive check target.	<ul style="list-style-type: none"> Unit [s]: 1 to 16383 Unit [ms]: 100 to 16383000 (Default: 10 s)
	Destination Alive Check Resend Count	Set the number of times to perform alive check when no response is returned from the external device of alive check target.	1 to 32767 (Default: 3 Times)

BACnet function setting

Set the BACnet functions.

Item	Description	Setting range
Whether the BACnet functions are used or not	Indicates the usage status of the BACnet/IP connection modules in the external device configuration. (This setting is automatically configured according to the setting details in the external device configuration.)	<ul style="list-style-type: none"> • Not used • Used (Default: Not used)
Network information setting	Network number	Set a BACnet network number.
		0 to 65534 (Default: 0)
BACnet device setting	Page 50 BACnet device setting	—
BACnet object setting	Page 51 BACnet object setting	—

BACnet device setting

Set a BACnet device.

Item	Description	Setting range
Instance No.	Set a BACnet instance number.	0 to 4194303 (Default: 0)
Object Name	Set a device name. (The same value cannot be set in a module.)	16 one-byte alphanumeric characters maximum (Default: Empty)
BACnet standards	Set the BACnet standards.	<ul style="list-style-type: none"> • ANSI/ASHRAE Standard 135-2016 • ANSI/ASHRAE Standard 135-2012 • ANSI/ASHRAE Standard 135-2010 • ANSI/ASHRAE Standard 135-2004 • IEIEJ-G-0006:2006 Addendum a (Default: ANSI/ASHRAE Standard 135-2016)
I-Am send setting	Send control	Set whether or not to send I-Am only when the device is set to Operational.
		<ul style="list-style-type: none"> • Send I-Am only at the Operational status. • Send I-Am even at other statuses than Operational. (Default: Send I-Am only at the Operational status.)
	Send I-Am when the status changes to Operational	Set whether or not to send I-Am when the device status changes to Operational.
		<ul style="list-style-type: none"> • Do not send • Send (Default: Send)
	Enable/disable fixedcycle send	Set whether or not to send I-Am at a fixed-cycle.
		<ul style="list-style-type: none"> • Disable • Enable (Default: Disable)
Fixed-cycle send interval (second)	Set the interval (second) for sending I-Am. (Available when the enable/disable fixed-cycle send is set to Enable)	1 to 4095 (Default: 60)
I-Am response setting	Set how to send I-Am and I-Have for Who-Is and Who-Has.	<ul style="list-style-type: none"> • RemoteBroadcast • GlobalBroadcast • LocalBroadcast • Unicast (Default: LocalBroadcast)
I-Am send setting	Set how to send the spontaneous I-Am.	<ul style="list-style-type: none"> • LocalBroadcast • GlobalBroadcast (Default: LocalBroadcast)

Item		Description	Setting range
Device restart procedure setting	Device restart procedure	Set the device restart procedure.	<ul style="list-style-type: none"> • Do not support • Support (Default: Do not support)
	Notification destination network number	Set a network number to which notification is sent at device restart. (Available when device restart is set to "Support")	0 to 65534 (Default: 0)
	Notification destination IP address	Set the IPv4 address to which notification is sent at device restart. (Available when device restart is set to "Support")	0.0.0.1 to 223.255.255.254 (Default: 192.168.0.254)
	Notification destination port number	Set a port number to which notification is sent at device restart. (Available when device restart is set to "Support")	0 to 65535 (Default: 47808)
Time synchronization setting		Set the response for receiving wild card.	<ul style="list-style-type: none"> • Ignore • Output to buffer memory (Default: Ignore)

BACnet object setting

Set the instance No., etc. of each object.

For details, refer to [MELSEC iQ-F FX5 User's Manual \(BACnet\)](#).

Item	Description	Setting range
Accumulator object setting	Set the Accumulator object.	—
AnalogInput object setting	Set AnalogInput object.	—
AnalogOutput object setting	Set AnalogOutput object.	—
AnalogValue object setting	Set AnalogValue object.	—
BinaryInput object setting	Set BinaryInput object.	—
BinaryOutput object setting	Set BinaryOutput object.	—
BinaryValue object setting	Set BinaryValue object.	—
Multi-stateInput object setting	Set Multi-state Input object.	—
Multi-stateOutput object setting	Set Multi-state Output object.	—

External Device Configuration

Set the conditions of the external devices with which the module will communicate through general-purpose Ethernet.

Double-click <Detailed Setting> of the "External Device Configuration".

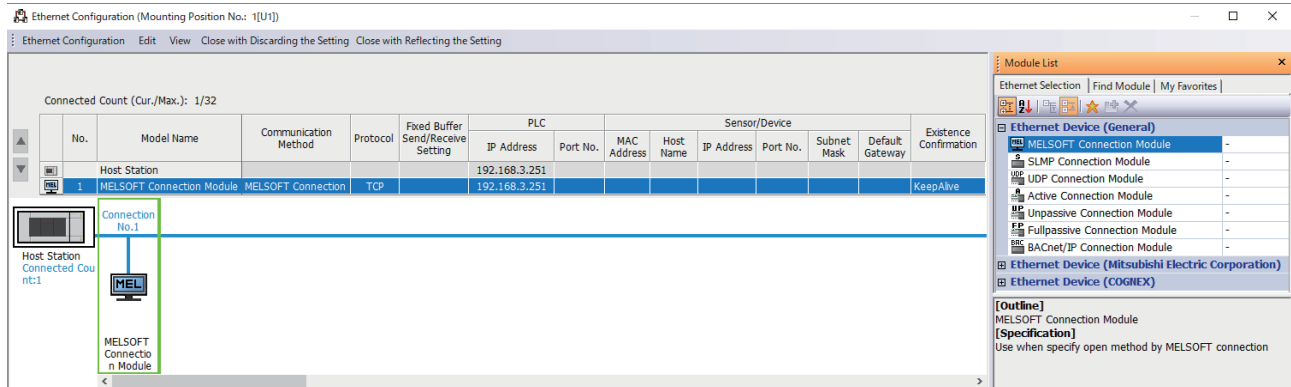

Drag and drop an "Ethernet Device" in the "Module List" to the left side of the screen, and set the following items. The setting items vary depending on the "Ethernet Device" and "Communication Method".

Item	Description	Setting range	
No.	Connection number for distinguishing settings for each user connection.	—	
Model Name	The name of the external device is displayed.	—	
Communication Method	Set the method for communication with the external device.*1	<ul style="list-style-type: none"> MELSOFT Connection SLMP Socket communication BACnet/IP 	
Protocol	Select the communication protocol for the external device.*1	<ul style="list-style-type: none"> TCP UDP 	
Fixed Buffer Send/Receive Setting	Not supported.	—	
PLC	IP Address	The IP address of host station (FX5-ENET/IP) is displayed.	
	Port No.	The port no. of host station (FX5-ENET/IP) is displayed.	
Sensor/Device	MAC Address	Not supported.	
	Host Name	Not supported.	
	IP Address	Set the IP address of the external device.	<ul style="list-style-type: none"> Blank 0.0.0.1 to 223.255.255.254 (Default: Blank)
	Port No.	Set the port no. of the external device.	<ul style="list-style-type: none"> Blank 1 to 65534 (Default: Blank)
	Subnet Mask	Set the subnet mask of the external device.	—
	Default Gateway	Set the default gateway of the external device.	—
Existence Confirmation	Select the method of alive check which is performed when the Ethernet-equipped module has not communicated with the external device for a certain period of time. When the module cannot communicate with the external device, the connection will be closed.*1	<ul style="list-style-type: none"> KeepAlive Do not confirm existence 	

*1 Automatically set by the "Ethernet Device".
The protocol can be selected only when "Communication Method" is "SLMP".

*2 Do not specify 5549 to 5569 because these ports are used by the system.

7.4 Application Settings

Set the following parameters when the functions of the general-purpose Ethernet will be used on FX5-ENET/IP.

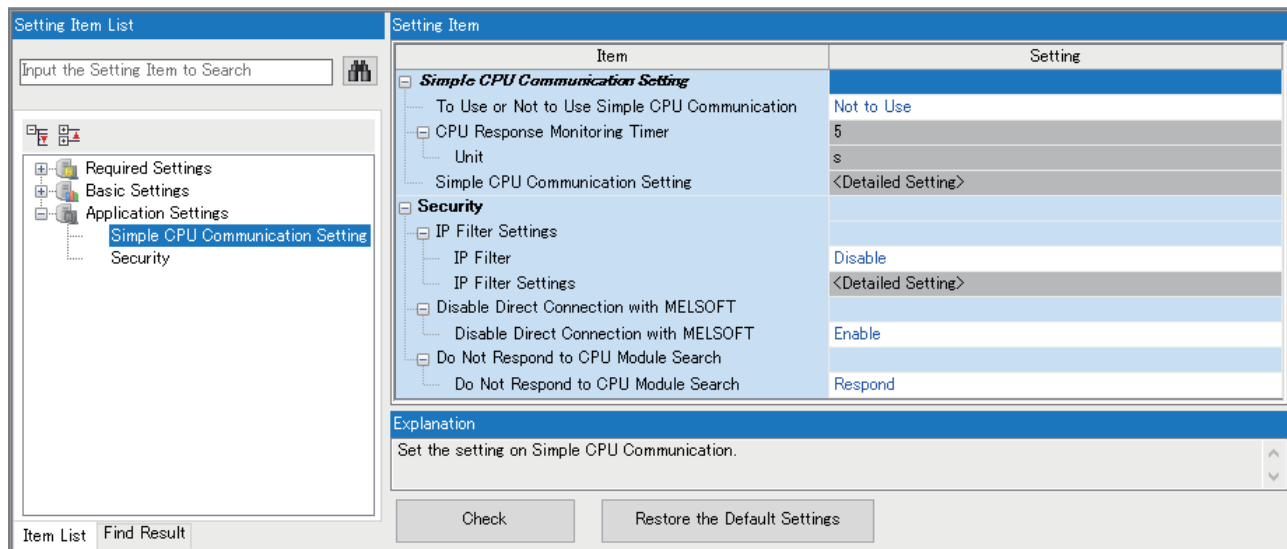

Simple CPU communication settings

Set the simple CPU communication.

Item	Description	Setting range
To Use or Not to Use Simple CPU Communication	Set whether to enable the simple CPU communication function.	<ul style="list-style-type: none"> • Not to Use • To Use (Default: Not to Use)
CPU Response Monitoring Timer	Set the time for monitoring the response from the FX5-ENET/IP. If the FX5-ENET/IP does not respond within the set time, the response wait state will be canceled.	<ul style="list-style-type: none"> • Unit [s]: 1 to 16383 • Unit [ms]: 100 to 16383000 (Default: 5 s)
Simple CPU Communication Setting	Set the details for simple CPU communication. For details, refer to MELSEC iQ-F FX5 User's Manual (Ethernet Communication).	—

Security

Set the security function.

Item	Description	Setting range
IP Filter Settings	IP Filter	<ul style="list-style-type: none"> • Disable • Enable (Default: Disable)
	IP Filter Settings	Set the IP address to be allowed or denied. (Page 54)
Disable Direct Connection with MELSOFT	Permit/prohibit direct connection with the engineering tool.	<ul style="list-style-type: none"> • Disable • Enable (Default: Enable)
Do Not Respond to CPU Module Search	Set whether to respond to search for the CPU modules on the network.	<ul style="list-style-type: none"> • Do Not Respond • Respond (Default: Respond)

IP Filter Settings

Set the IP address for which the IP filter function will be used.

Double-click <Detailed Setting> of the "IP Filter Settings".

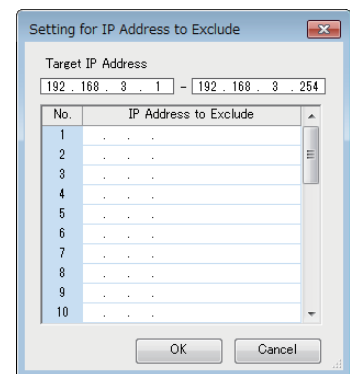
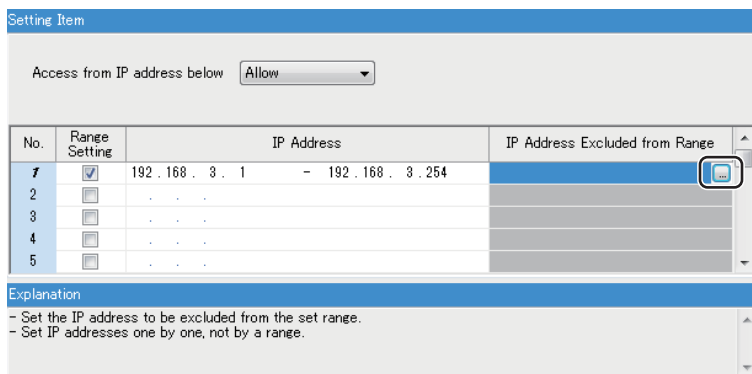

Item	Description	Setting range
Access from IP address below	Select whether to allow or deny the access from the specified IP addresses.	<ul style="list-style-type: none"> • Allow • Deny (Default: Allow)
Range Setting	Select this item when specifying the IP addresses by range.	—
IP Address	Set the IP address to be allowed or denied. When selecting "Range Setting", enter the start IP address (left field) and end IP address (right field) of the range.	<ul style="list-style-type: none"> • Blank • 0.0.0.1 to 223.255.255.254 (Default: Blank)
IP Address Excluded from Range	When selecting "Range Setting", set the IP address to be excluded from the set range. Up to 32 IP addresses can be set.	<ul style="list-style-type: none"> • Blank • 0.0.0.1 to 223.255.255.254 (Default: Blank)

7.5 Setting EtherNet/IP Communications (Starting EtherNet/IP Configuration Tool for FX5-ENET/IP)

Start EtherNet/IP Configuration Tool for FX5-ENET/IP, and then set EtherNet/IP communications.

Operating procedure

1. Display the "Module Tool List" window on GX Works3.

 [Tool] ⇒ [Module Tool List]

2. Start EtherNet/IP Configuration Tool for FX5-ENET/IP.

 [Information Module] ⇒ [EtherNet/IP Configuration Tool]

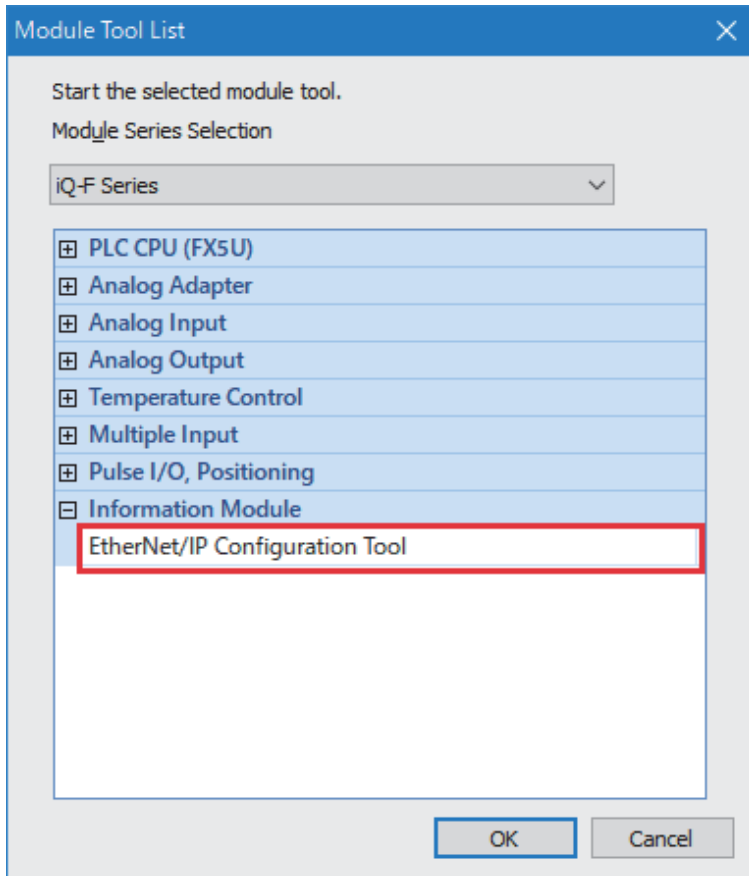

3. Set the parameters for EtherNet/IP communications.

For details, refer to the following.

 Page 57 EtherNet/IP Configuration Tool for FX5-ENET/IP

Point

- To start EtherNet/IP Configuration Tool for FX5-ENET/IP on the "Module Tool List" window, the GX Works3 version must be "1.080J" or later. If a GX Works3 version is earlier than "1.080J", start EtherNet/IP Configuration Tool for FX5-ENET/IP from the start menu or shortcut created when it was installed.
- Even if the GX Works3 is closed while EtherNet/IP Configuration Tool for FX5-ENET/IP is starting, it can operate independently. Configuration tool operations can continue.
- While EtherNet/IP Configuration Tool for FX5-ENET/IP is running, another EtherNet/IP Configuration Tool for FX5-ENET/IP cannot be started.

7.6 Writing Parameters

The parameters set on the FX5-ENET/IP have different write destinations.

Parameter type	Configuration tool	Write destination
Module parameter	GX Works3	CPU module
EtherNet/IP communication setting	EtherNet/IP Configuration Tool for FX5-ENET/IP	FX5-ENET/IP

For writing parameters to the CPU module, refer to the following.

 GX Works3 Operating Manual

This section describes writing procedure to the FX5-ENET/IP.

Operating procedure

1. Switch EtherNet/IP Configuration Tool for FX5-ENET/IP to the online state.

 [File] ⇨ [Go Online]

2. Write the set parameters to the FX5-ENET/IP.

 [File] ⇨ [Download]

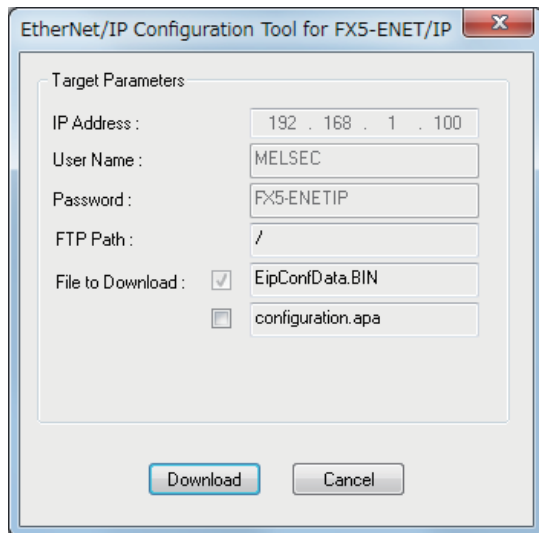

Point

The parameters written to the FX5-ENET/IP with EtherNet/IP Configuration Tool for FX5-ENET/IP are reflected when the following operations are executed.

- The power supply of FX5-ENET/IP (CPU module) is turned off and on.

8 EtherNet/IP Configuration Tool for FX5-ENET/IP

This chapter describes operations of EtherNet/IP Configuration Tool for FX5-ENET/IP.

8.1 Window Structure

The following figure shows the window structure.

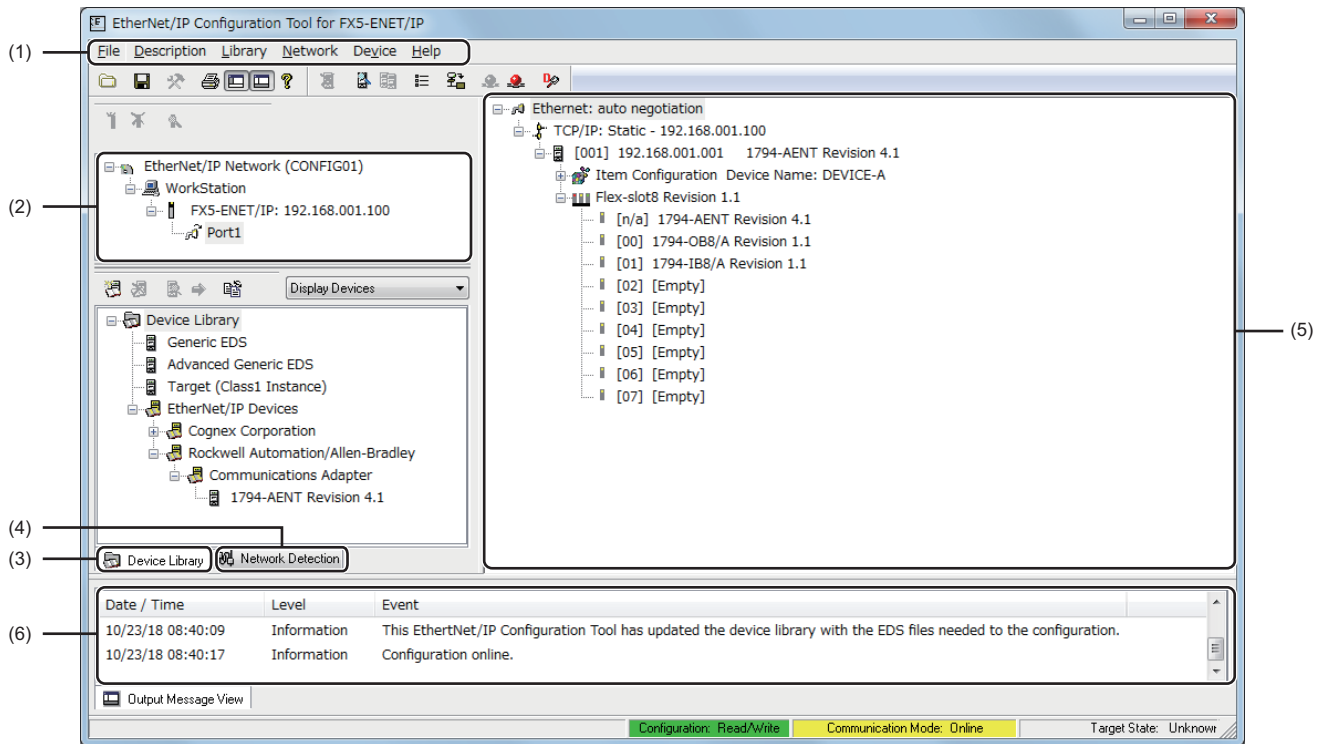

No.	Name	Reference
(1)	Menu	Page 58
(2)	EtherNet/IP setting	Page 65
(3)	Device Library	Page 67
(4)	Network Detection	Page 69
(5)	Network configuration setting	Page 75
(6)	Operation information list	Page 99

Menu

The following table lists the menu items of EtherNet/IP Configuration Tool for FX5-ENET/IP.

Item	Description	Reference
File	Saves a project and configures print setting and window structure.	Page 58
Description	Sets the FX5-ENET/IP information.	Page 62
Library	Performs operations such as adding EDS files, displaying EDS file information, and adding EtherNet/IP devices.	Page 62
Network	Performs operations such as detecting EtherNet/IP devices on the network to add them to the network configuration settings and configuring the settings for EtherNet/IP communications.	Page 63
Device	Performs operations such as adding the selected EtherNet/IP device to the network configuration settings, configuring the settings for EtherNet/IP devices, and enabling diagnostic mode.	Page 64
Help	Displays the help or version information of EtherNet/IP Configuration Tool for FX5-ENET/IP.	Page 64

File

Save a project and configure print setting and window structure.

Item	Description
Save	Saves an EtherNet/IP Configuration Tool for FX5-ENET/IP project.
List and Print	Opens the "Preview or Print Listings" window. (☞ Page 59 "Preview or Print Listings" window)
Download	Opens the download window. (☞ Page 59 Download window)
Verify	Opens the structure setting check window. (☞ Page 60 Structure setting check window)
Upload	Opens the upload window. (☞ Page 61 Upload window)
Go Online	Enables online mode.*1
Go Offline	Disables online mode. This mode is disabled by default.
Preferences	Selects a window structure layout and "Advanced Mode". <ul style="list-style-type: none"> • Clicking "Workspace": Displays or hides the EtherNet/IP settings, "Device Library", and "Network Detection". • Clicking "Output Window": Displays or hides the operation information list. • Selecting "Advanced Mode": Enables configuration of detailed EtherNet/IP settings in each setting window.
Message View	Performs the following actions on the operation information list. <ul style="list-style-type: none"> • Copy: Copies the information displayed in the operation information list. • Clear: Clears the information displayed in the operation information list. • Configuration: Sets the information displayed in the operation information list. (☞ Page 99 "Output Message View Configuration" window)
Exit	Exits EtherNet/IP Configuration Tool for FX5-ENET/IP.

- *1 The following dialog appears when the changed project setting is not stored in EtherNet/IP Configuration Tool for FX5-ENET/IP.
- Click [Yes] to save the project and enable the online mode.
 - Click [No] to enable the online mode without saving the project.

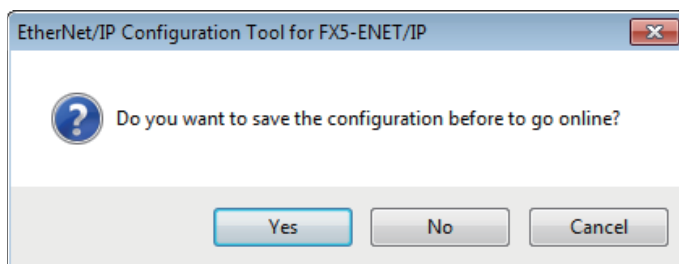

■ "Preview or Print Listings" window

Print the information of the current network configuration settings.

 [File] ⇨ [List and Print]

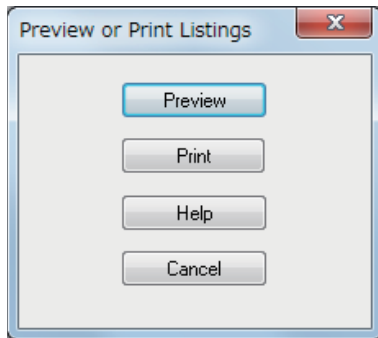

Item	Description
[Preview] button	Displays the information of the network configuration settings in a text file.
[Print] button	Prints the selected information.
[Help] button	Displays the help.
[Cancel] button	Closes the "Preview or Print Listings" window.

■ Download window

The information of the current network configuration settings is written to the FX5-ENET/IP.

 [File] ⇨ [Download]

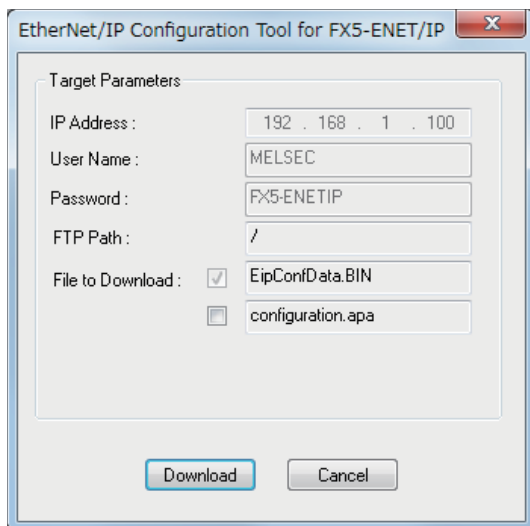

Item	Description	Setting range
IP Address	Displays the IP address of the FX5-ENET/IP.	—
User Name	Displays the name.	— (Fixed to MELSEC.)
Password	Displays the password.	— (Fixed to the FX5-ENET/IP.)
FTP Path	Displays the FTP path.	—
File to Download	When these check boxes are selected, EipConfData.BIN and configuration.apa will be overwritten. ^{*1*2} (The check box for EipConfData.BIN cannot be cleared.)	• Selected • Not selected (Default: Not selected)
[Download] button	Performs writing with the set details. The writing result is displayed in a dialog box.	—
[Cancel] button	Closes the download window.	—

*1 EipConfData.BIN is the data used to manage the information of the network configuration settings.

*2 Configuration.apa is the data containing the IP address of the FX5-ENET/IP set in the EtherNet/IP setting and the EtherNet/IP device configuration and parameter settings set in the network configuration setting.

■ Structure setting check window

Verify the information of the network configuration settings saved on the FX5-ENET/IP (EipConfData.BIN) against the information of the network configuration settings of EtherNet/IP Configuration Tool for FX5-ENET/IP (EipConfData.BIN) to check whether they are the same.

 [File] ⇨ [Verify]

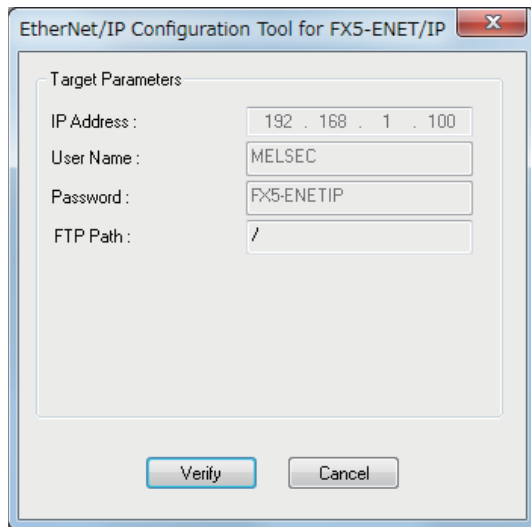

Item	Description	Setting range
IP Address	Displays the IP address of the FX5-ENET/IP.	—
User Name	Displays the name.	— (Fixed to MELSEC.)
Password	Displays the password.	— (Fixed to the FX5-ENET/IP.)
FTP Path	Displays the FTP path.	—
[Verify] button	Performs verification with the set details. The verification result is displayed in a dialog box.	—
[Cancel] button	Closes the structure setting check window.	—

■Upload window

The information of the network configuration settings saved on the FX5-ENET/IP is read.

 [File] ⇨ [Upload]

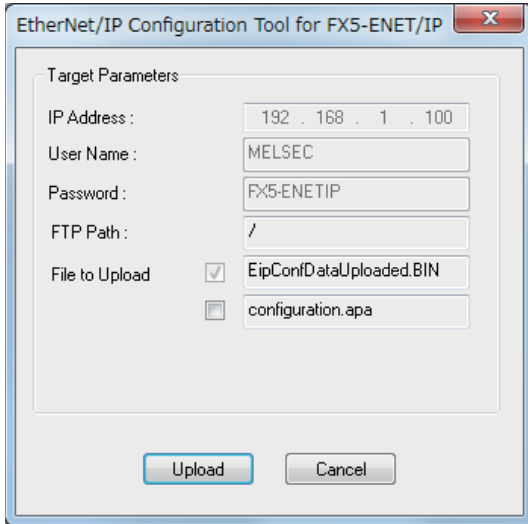

Item	Description	Setting range
IP Address	Displays the IP address of the FX5-ENET/IP.	—
User Name	Displays the name.	— (Fixed to MELSEC.)
Password	Displays the password.	— (Fixed to the FX5-ENET/IP.)
FTP Path	Displays the FTP path.	—
File to Upload	When these check boxes are selected, EipConfDataUploaded.BIN and configuration.apa will be overwritten.*1*2 (The check box for EipConfDataUploaded.BIN cannot be cleared.)	<ul style="list-style-type: none"> • Selected • Not selected (Default: Not selected)
[Upload] button	Performs reading with the set details. The reading result is displayed in a dialog box.	—
[Cancel] button	Closes the upload window.	—

*1 EipConfDataUploaded.BIN is the data used to manage the information of the network configuration settings.

*2 Configuration.apa is the data containing the IP address of the FX5-ENET/IP set in the EtherNet/IP setting and the EtherNet/IP device configuration and parameter settings set in the network configuration setting.

Description

Set the FX5-ENET/IP information.

Item	Description
Add	Adds the FX5-ENET/IP information. (The FX5-ENET/IP information can be added when the existing information is deleted using "Delete".) ^{*1}
Delete	Deletes the FX5-ENET/IP information. ^{*2}
Properties	Opens the "Element Properties" window. (☞ Page 65 "Element Properties" window) ^{*2}

*1 This action can be performed when WorkStation is selected in the EtherNet/IP setting. (☞ Page 57 Window Structure)

*2 This action can be performed when the FX5-ENET/IP is selected in the EtherNet/IP setting. (☞ Page 57 Window Structure)

Library

Set operations such as adding EDS files, displaying file information, and adding EtherNet/IP devices.

This item can be selected when "Device Library" is displayed.

Item	Description
Add	Opens the EDS Management wizard to add EDS files. (☞ Page 100 Adding the EDS file)
Delete	Deletes selected EtherNet/IP devices from "Device Library".
Sort	Opens the "Sort Device Library" window. (☞ Page 62 "Sort Device Library" window)
Insert in Configuration	Adds the selected EtherNet/IP device to the network configuration settings. (☞ Page 103 Configuring settings offline)
Properties	Displays the EDS file information of the selected EtherNet/IP device. (☞ Page 68 EDS file information)

■ "Sort Device Library" window

Select the display order of the EtherNet/IP devices added in "Device Library".

☞ [Library] ⇒ [Sort]

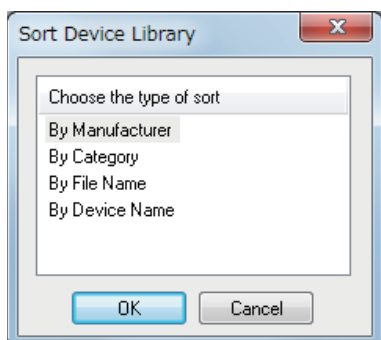

Item	Description
By Manufacturer	Displays EtherNet/IP devices by device manufacturer name.
By Category	Displays EtherNet/IP devices by vendor name.
By File Name	Displays EtherNet/IP devices by EDS file name.
By Device Name	Displays EtherNet/IP devices by name.

Network

Perform operations such as detecting EtherNet/IP devices on the network to add them to the network configuration settings and configuring the settings for EtherNet/IP communications.

This item can be selected when EtherNet/IP Configuration Tool for FX5-ENET/IP is switched to the online state and "Network Detection" is displayed. (☞ Page 57 Window Structure)

Item	Description
Choose Network Adapter	Opens the "Choose Network Adapter" window. (☞ Page 63 "Choose Network Adapter" window)
Read Network Configuration	Scans the network to detect EtherNet/IP devices on the "Network Detection" tab. (☞ Page 69 Detecting the FX5-ENET/IP and EtherNet/IP devices)
Online Action	Opens the "Online Action" window. (☞ Page 71 "Online Action" window)
Insert in Configuration	Adds the selected EtherNet/IP device to the network configuration settings. (☞ Page 103 Configuring settings online)
Insert and Replace All	Deletes all the EtherNet/IP devices set in the network configuration settings and adds all the EtherNet/IP devices detected by "Network Detection".
Properties	Opens the properties of the selected EtherNet/IP device. (☞ Page 70 EtherNet/IP device properties) ^{*1}

*1 This action can be performed when an EtherNet/IP device to which a module can be mounted is selected in "Network Detection".
(☞ Page 57 Window Structure)

■ "Choose Network Adapter" window

Select the network adapter to use in EtherNet/IP communications from the list of network adapters detected with EtherNet/IP Configuration Tool for FX5-ENET/IP.

When the "Automatic" check box is selected, all the detected network adapters are used in EtherNet/IP communications.



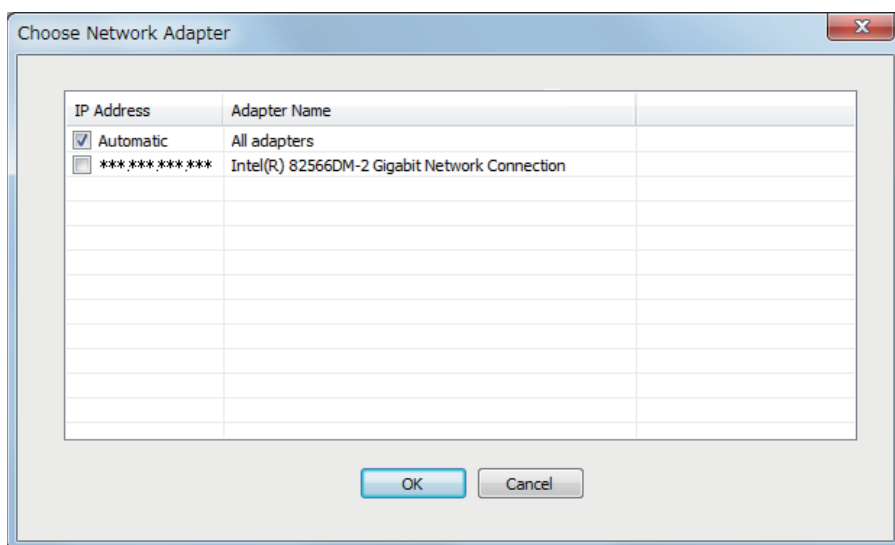



☞ [Network] ⇔ [Choose Network Adapter]



Item	Description
IP Address	Displays the IP address of the network adapter.
Adapter Name	Displays the name of the network adapter.

Device

Perform operations such as adding the selected EtherNet/IP device to the network configuration settings, configuring the settings for EtherNet/IP devices, and enabling diagnostic mode.

Item	Description
Duplicate	Adds a copy of the selected EtherNet/IP device to the network configuration settings.* ¹
Delete	Deletes the selected EtherNet/IP device from the network configuration settings.* ¹
Add	Adds the modules for EtherNet/IP devices to which modules can be mounted.* ²
Collapse/Expand All	Collapses/expands the module tree in the network configuration settings.
Properties	Opens the properties of a selected item as shown below. <ul style="list-style-type: none">• When "Ethernet" in the network configuration settings is selected:  Page 77 "Channel Properties" window• When the EtherNet/IP module display in the network configuration settings is selected:  Page 83 IP address management window• When the EtherNet/IP display in the network configuration settings is selected:  Page 84 EtherNet/IP device setting window (Class1 instance communications)• When other item in the network configuration settings is selected: The window corresponding to the selected item is displayed. Displayed content varies depending on the EtherNet/IP device used. For names of each display, refer to the following.  Page 69 Display content
Diagnostic	Enables diagnostic mode. ( Page 118 Network diagnostics of EtherNet/IP Configuration Tool for FX5-ENET/IP)* ³
Options	Opens the "Display Option" window. ( Page 76 "Display Option" window)

*¹ This action can be performed when an EtherNet/IP device is selected in the network configuration settings. ( Page 57 Window Structure)

*² This action can be performed when an EtherNet/IP device to which a module can be mounted is selected in the network configuration settings.

*³ This action can be performed when EtherNet/IP Configuration Tool for FX5-ENET/IP is switched to the online state. ( Page 58 File)

Help

The help or version information of EtherNet/IP Configuration Tool for FX5-ENET/IP is displayed.

Item	Description
EIT CT Help	Opens the help of EtherNet/IP Configuration Tool for FX5-ENET/IP.
About	Displays the version information of EtherNet/IP Configuration Tool for FX5-ENET/IP. ( Page 104 Checking the Software Version)

EtherNet/IP setting

EtherNet/IP setting displays the project information of the FX5-ENET/IP set with EtherNet/IP Configuration Tool for FX5-ENET/IP.

"Element Properties" window

Set the IP address of the FX5-ENET/IP.

Set the same IP address as that set in "Basic Setting" in the GX Works3.

☞ Select "FX5-ENET/IP" in the EtherNet/IP setting ⇒ [Description] ⇒ [Properties]

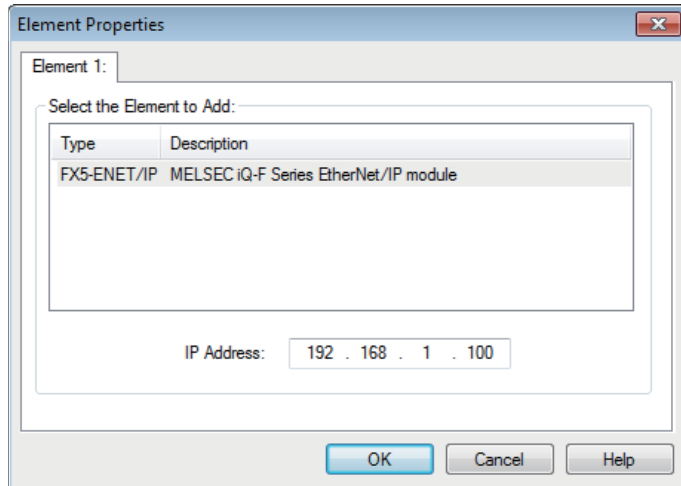

"Configuration Manager" window

Manage the project of EtherNet/IP Configuration Tool for FX5-ENET/IP.

Right-click "Ethernet/IP Network" in the EtherNet/IP setting ⇒ [Configuration Manager]

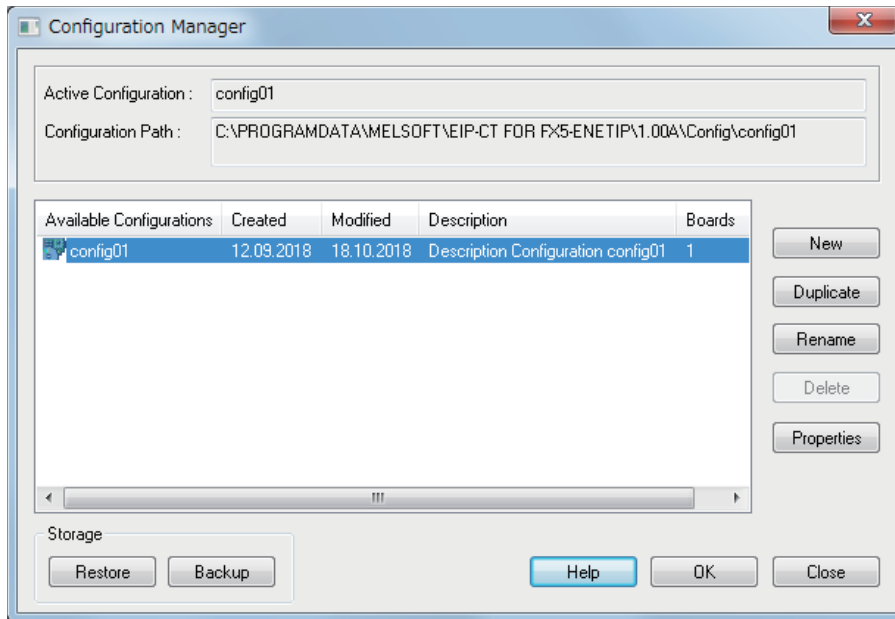

Item	Description
Active Configuration	Displays the name of the currently active project.
Configuration Path	Displays the storage location of the currently active project file.
[New] button	Creates a new project.
[Duplicate] button	Creates a new project from the copy of the selected project.
[Rename] button	Changes the name of the selected project.
[Delete] button	Deletes the selected project.
[Properties] button	Displays the property of the selected project.
[Restore] button	Restores the backup copy of the specified project file.
[Backup] button	Stores the backup copy of the selected project.

Device Library

"Device Library" lists the EtherNet/IP devices added in EtherNet/IP Configuration Tool for FX5-ENET/IP.

The EtherNet/IP devices added to "Device Library" can be added to the network configuration settings.

When EtherNet/IP device information is displayed at execution of Network Detection, the information of the EtherNet/IP devices added to "Device Library" is used.

To add EtherNet/IP devices to "Device Library", add EDS files provided by manufacturers of the EtherNet/IP devices in EtherNet/IP Configuration Tool for FX5-ENET/IP. For details, refer to the following.

☞ Page 100 Adding the EDS file

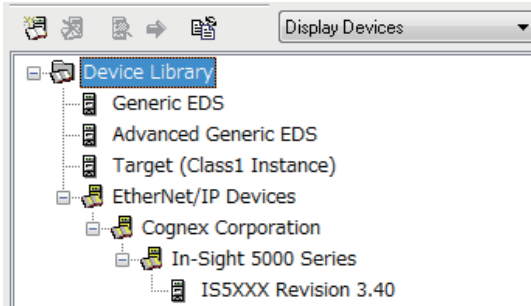

Point

Perform the action related to "Device Library" when it is set offline. For the operating procedure, refer to the following.

☞ Page 103 Configuring settings offline

Display options

The list of display options in the upper-right corner of the "Device Library" can be used to switch its display.

Item	Description
Display Devices	Displays the EtherNet/IP devices not configured by modules.
Display Modules and Chassis	Displays the EtherNet/IP devices configured by modules.
Display all Nodes	Displays all the EtherNet/IP devices.

EDS file information

The EDS file information of the EtherNet/IP device is displayed.

Select the EtherNet/IP device in "Device Library" ⇒ [Library] ⇒ [Properties]

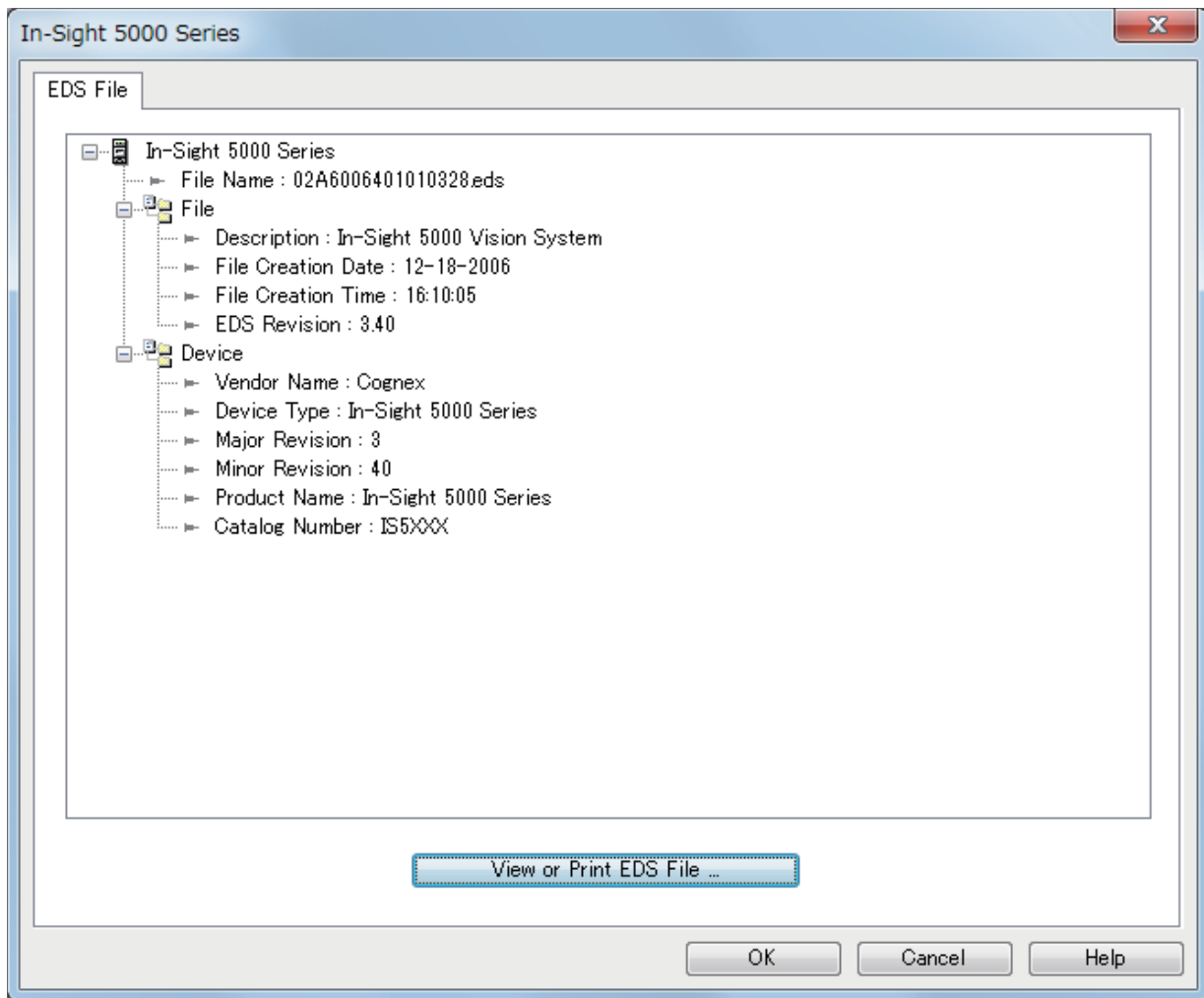

Item	Description
[View or Print EDS File] button	Displays EDS file information in the text format.

Network Detection

"Network Detection" detects EtherNet/IP devices on the network and configures EtherNet/IP communication settings online.

Detecting the FX5-ENET/IP and EtherNet/IP devices

Scan the network to detect the FX5-ENET/IP and EtherNet/IP devices on the "Network Detection" tab.

Select the [Network Detection] tab*1 ⇒ [Network] ⇒ [Read Network Configuration]

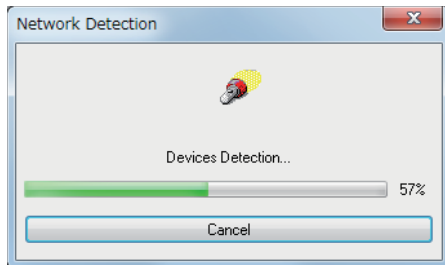

*1 For the [Network Detection] tab, refer to the following.
☞ Page 57 Window Structure

Display content

The "Network Detection" content is displayed.

"Network Detection" displays the FX5-ENET/IP and EtherNet/IP devices.

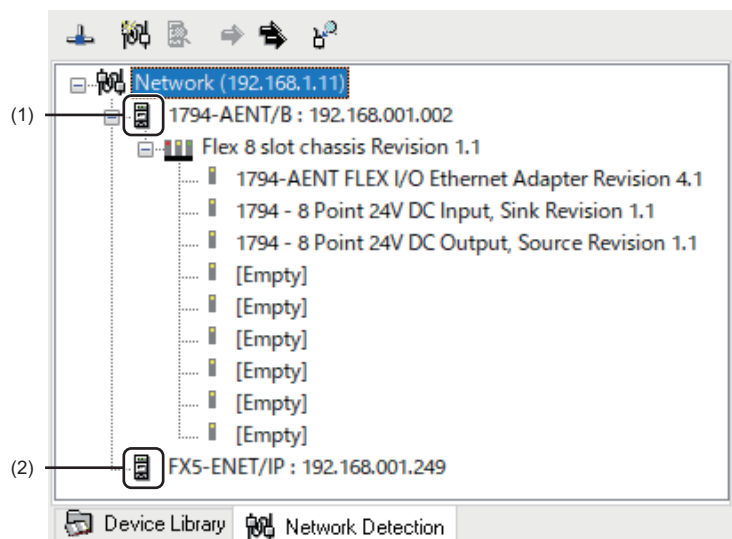

(1) Indicates that the EDS file for the detected FX5-ENET/IP or EtherNet/IP device is added in "Device Library".
(2) Indicates that the EDS file for the detected FX5-ENET/IP or EtherNet/IP device is not added in "Device Library".

When detecting EtherNet/IP devices on the network, note the following points.

- The FX5-ENET/IP and EtherNet/IP devices must be connected to the network.
- An IP address has been set to the EtherNet/IP device, and the IP address does not duplicate the IP addresses of other EtherNet/IP devices.*1
- The EDS file of each EtherNet/IP device has been added to "Device Library". (The EtherNet/IP communication settings are based on the EDS files or Generic EDS.)*2

*1 The EtherNet/IP device IP address can be set in the "Online Action" window. (☞ Page 71 "Online Action" window)

*2 EDS files can be added in the "EDS Management" window. (☞ Page 100 Adding the EDS file)

Point

Perform the action related to "Network Detection" when it is set online. For the operating procedure, refer to the following.

☞ Page 103 Configuring settings online

EtherNet/IP device properties

The properties of an EtherNet/IP device in "Network Detection" is displayed.

Select the EtherNet/IP device module in "Network Detection". ⇒ [Network] ⇒ [Properties]

Point

This window shows properties of an EtherNet/IP device to which a module can be mounted.
No properties are displayed for EtherNet/IP devices to which a module cannot be mounted.

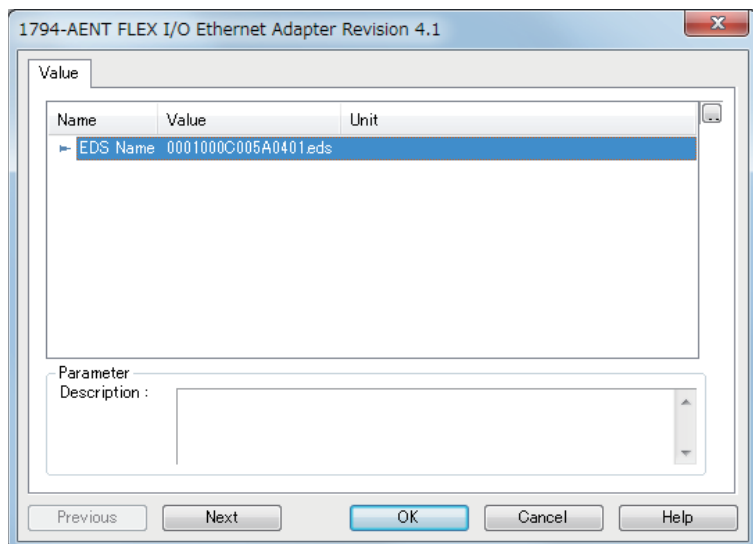

Item	Description
EDS Name	Displays the EDS file name of the EtherNet/IP device.
Description	Displays the description of the selected item.

"Online Action" window

The "Online Action" window is used to perform Class3 message communications and UCMM message communications. Items in this window can be used when EtherNet/IP Configuration Tool for FX5-ENET/IP is switched to the online state.
(Page 58 File)

Select the [Network Detection] tab ⇒ [Network] ⇒ [Online Action]

■[Explicit Message] tab

Use this tab when performing message communications with an EtherNet/IP device.

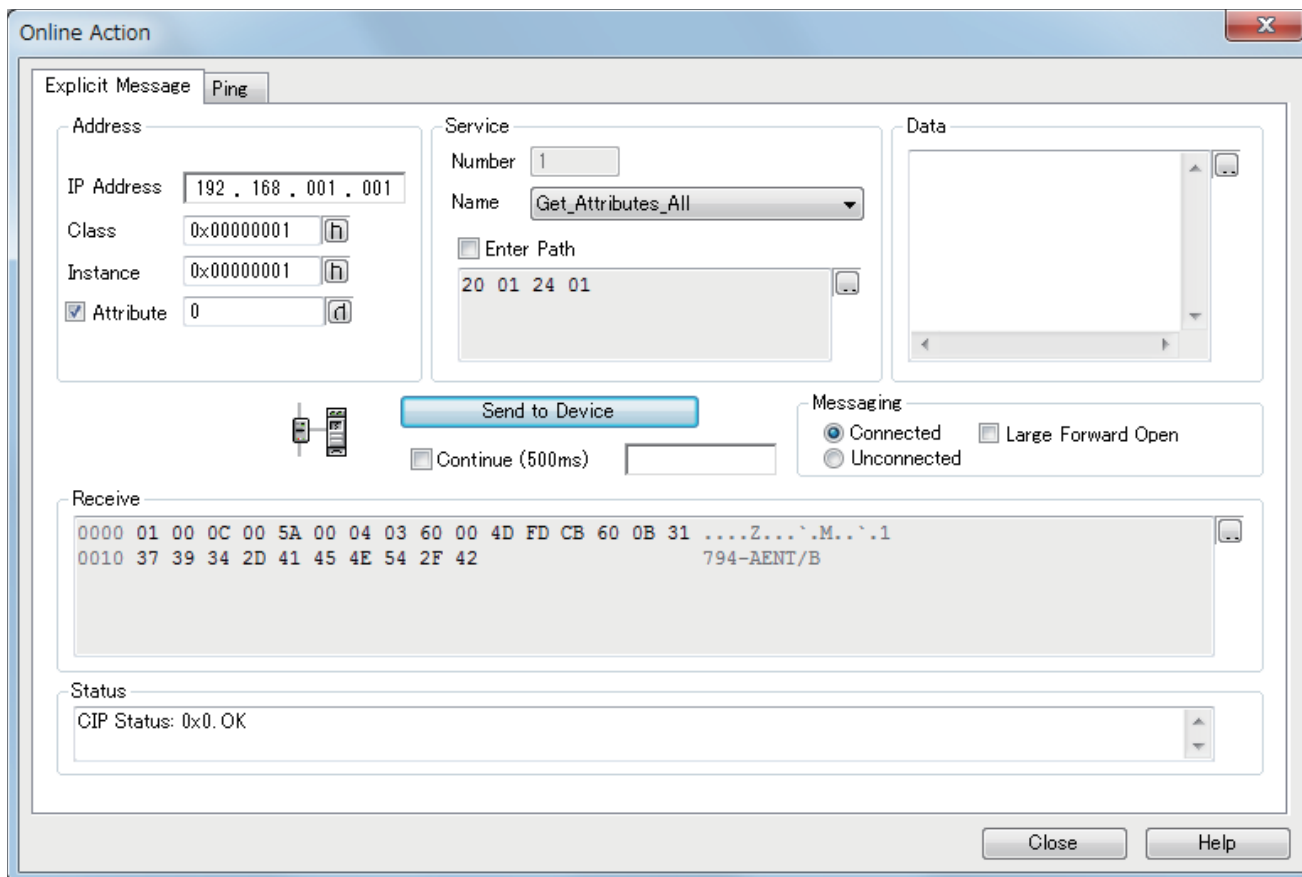

Item	Description	Setting range	
Address	IP Address	Specifies the IP address of the EtherNet/IP device to perform Class3 communications and UCMM communications with. The valid range of IP address is 0.0.0.1 to 223.255.255.254.	0.0.0.0 to 255.255.255.255 (Default: Current IP address of the EtherNet/IP device)
	Class	Specifies the class ID for performing message communications.	0 to 4294967295 (Default: 0)
	Instance	Specifies the instance ID for performing message communications.	0 to 4294967295 (Default: 0)
	Attribute	Specifies the attribute ID for performing message communications.	0 to 4294967295 (Default: 0)
Service	Number	Specifies the service value for performing message communications. This item cannot be entered if a value other than "Customer Service" is specified for "Name".	0 to 255 (Default: 14)
	Name	Specifies the service for performing message communications. To specify the service that is not displayed in this item, specify "Customer Service", and specify a value for "Number". Although there are other setting items than those described to the right, they are not supported on the FX5-ENET/IP. ¹	<ul style="list-style-type: none"> Customer Service Get_Attribute_Single Set_Attribute_Single Get_Attributes_All (Default: Get_Attributes_Single)
	Enter Path ²	When this check box is selected, the following items can be input. <ul style="list-style-type: none"> Identifier of CIP object Instance Attribute of instance 	<ul style="list-style-type: none"> Selected Not selected (Default: Not selected)
Data	Enters the data to send to the EtherNet/IP device.	—	

Item	Description	Setting range
[Send to Device] button	Starts Class3 communications and UCMM communications.	—
Continue (500ms)	When this check box is selected, Class3 communications and UCMM communications will be executed repeatedly at intervals of 500 ms.	<ul style="list-style-type: none"> • Selected • Not selected (Default: Not selected)
Messaging	Selects the communication method. <ul style="list-style-type: none"> • Connected: Class3 communications • Unconnected: UCMM communications When selecting "Connected", select whether to use "Large Forward Open". <ul style="list-style-type: none"> • Selected: Performs Class3 communications using Large Forward Open.^{*3} • Not selected: Performs Class3 communications using Forward Open.^{*4} 	<ul style="list-style-type: none"> • Connected • Unconnected (Default: Unconnected)
Receive	Displays the response data from the EtherNet/IP device. The response data is the data excluding the first four bytes including the CIP service code and the status code. ^{*5}	—
Status	Displays the communication result. For details, refer to the manuals of the EtherNet/IP device.	—

*1 To perform message communications with products other than the FX5-ENET/IP, refer to the manual of the product used.

*2 This item is displayed when "Advanced Mode" is selected. ( Page 58 File)

*3 Large Forward Open is used when the size of data to be sent/received is 512 bytes or more.

*4 Forward Open is used when the size of data to be sent/received is 511 bytes or less.

*5 Due to the restrictions of EtherNet/IP Configuration Tool for FX5-ENET/IP, when the response data exceeds 1410 bytes, the response data is not displayed and "Status = 58 (0x3A), Status EtherNet/IP = 0 (0x0)" is displayed in "Status".

■[Port Configuration] tab

Read and write the connection status of the EtherNet/IP device.

This tab can be used when the "Online Action" window is displayed with an EtherNet/IP device selected.

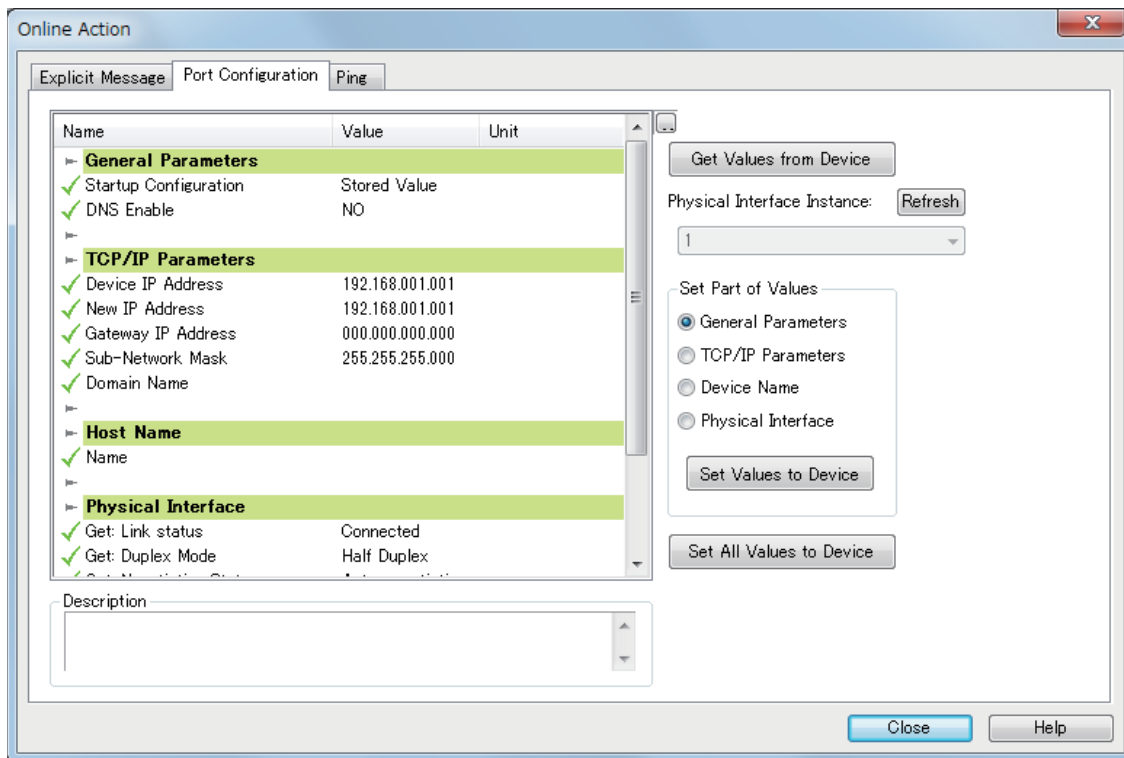

Item	Description
[Get Values from Device] button	Reads and displays the connection status of the EtherNet/IP device.
Physical Interface Instance	Specifies the port number from the list when the EtherNet/IP device is configured with multiple ports.
[Refresh] button	Updates the port number of the "Physical Interface Instance".
Set Part of Values	Selects the items of the values to write to the EtherNet/IP device from the following. <ul style="list-style-type: none"> • General Parameters: Basic parameter settings • TCP/IP Parameters: TCP/IP parameter settings • Device Name: Device name settings • Physical Interface: Physical interface settings
[Set Values to Device] button	Writes the values of the items selected with "Set Part of Values" to the EtherNet/IP device.
[Set All Values to Device] button	Writes all the values of the displayed connection status to the EtherNet/IP device.
Description	Displays the description of the selected item.
[Set Chassis Size in the Device] button	Sets the number of modules to be mounted to the slice-type EtherNet/IP device. Writing the specified number of modules enables error detection when the specified number is different from that of the actual system or when an error occurs on the module.

■[Ping] tab

Check for the existence of the EtherNet/IP device with the specified IP address over EtherNet/IP.

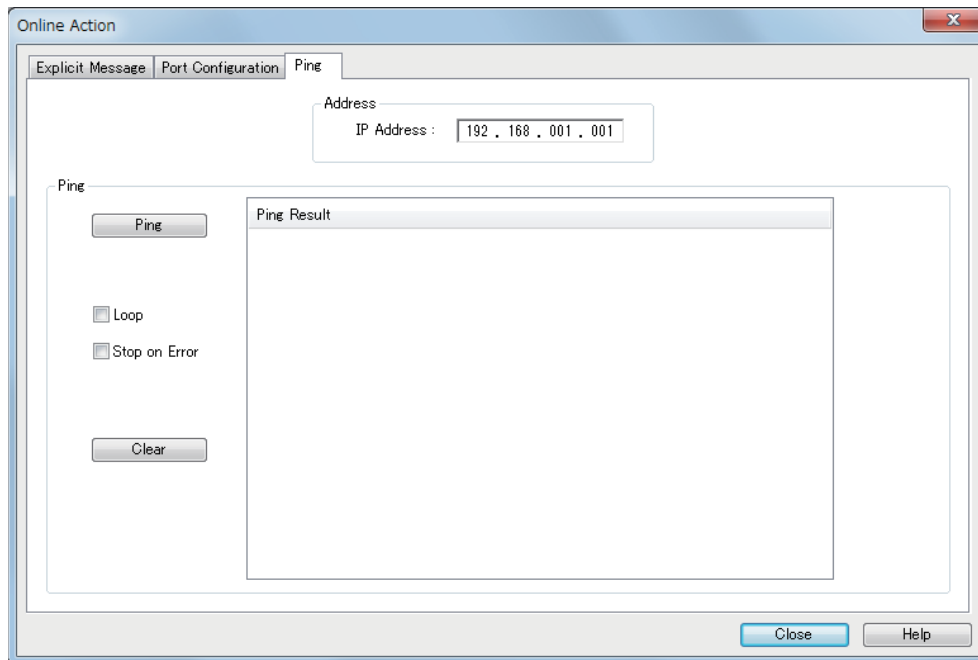

Item		Description	Setting range
Address	IP Address	Specifies the IP address of the EtherNet/IP device to ping.	0.0.0.0 to 255.255.255.255 (Default: Current IP address of the EtherNet/IP device)
Ping	[Ping] button	Pings the specified EtherNet/IP device.	—
	Loop	Select this check box to repeatedly ping the device once every 100 ms.	<ul style="list-style-type: none"> • Selected • Not selected (Default: Not selected)
	Stop on Error	Sets whether to interrupt pinging if an error occurs when the "Loop" check box is selected. <ul style="list-style-type: none"> • Selected: Pinging will be interrupted if an error occurs. • Not selected: Pinging will continue even if an error occurs. 	<ul style="list-style-type: none"> • Selected • Not selected (Default: Not selected)
	[Clear] button	Deletes the content of "Ping Result".	—
	Ping Result	Displays the result of pinging.	—

Network configuration settings

Network configuration settings are used for check the EtherNet/IP device settings and the connection status.

Display content

The network configuration settings is displayed.

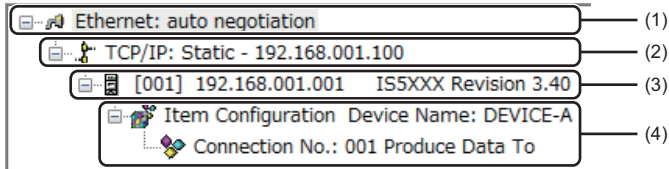

No.	Display area	Display example	Display description
(1)	Ethernet		— (Fixed to the display shown on the left)
(2)	EtherNet/IP module display		① IP address of the FX5-ENET/IP
(3)	EtherNet/IP device display		① Device number of the EtherNet/IP device ^{*1} ② IP address of the EtherNet/IP device ③ Product name of the EtherNet/IP device
(4)	Item display		① Name of the EtherNet/IP device ^{*2} ② Connection number ^{*3}

*1 The device number is used to manage the EtherNet/IP device in EtherNet/IP Configuration Tool for FX5-ENET/IP.

*2 The name set for "Device Name" in the [General] tab in the EtherNet/IP device setting window is used.

*3 When buffer memory areas are used and their bits need to be specified for each connection, the connection number is used to distinguish each connection.

"Display Option" window

The display of the network configuration settings can be changed.

 [Device] ⇄ [Options]

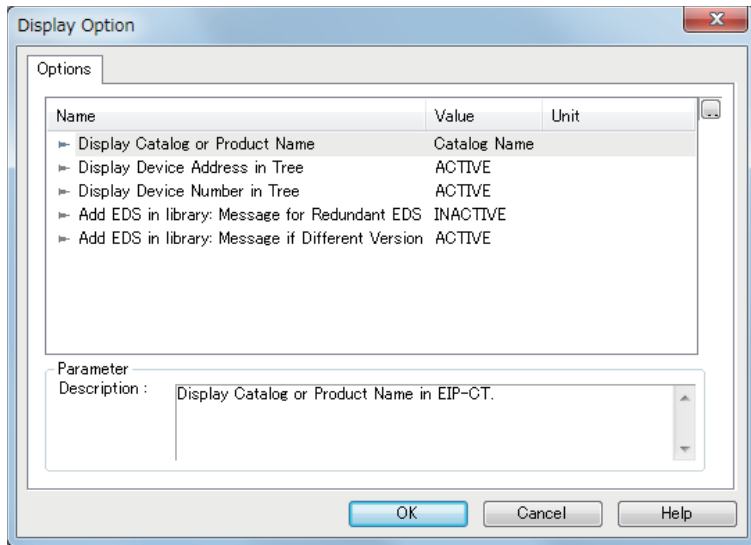

Item	Description	Setting range
Display Catalog or Product Name	Changes the display method according to the EtherNet/IP device product name. Select the "Catalog Name" or "Product Name" set with the EDS file.	<ul style="list-style-type: none"> • Product Name • Catalog Name (Default: Catalog Name)
Display Device Address in Tree	Displays the IP address of each EtherNet/IP device in the navigation tree of the network configuration settings when "ACTIVE" is selected.	<ul style="list-style-type: none"> • ACTIVE • INACTIVE (Default: ACTIVE)
Display Device Number in Tree	Displays the device number in the navigation tree of the network configuration settings when "ACTIVE" is selected.	<ul style="list-style-type: none"> • ACTIVE • INACTIVE (Default: ACTIVE)
Add EDS in library: Message for Redundant EDS	Displays a message when an EDS file is added and the same EDS file exists when "ACTIVE" is selected. When "INACTIVE" is selected, the message is not displayed.	<ul style="list-style-type: none"> • ACTIVE • INACTIVE (Default: ACTIVE)
Add EDS in library: Message if Different Version	Displays a message when an EDS file is added and the same EDS file with a different version exists when "ACTIVE" is selected. When "INACTIVE" is selected, the message is not displayed.	<ul style="list-style-type: none"> • ACTIVE • INACTIVE (Default: ACTIVE)
Parameter Description	Displays the description of the selected item.	—

"Channel Properties" window

The information of the EtherNet/IP devices set in the network configuration settings is displayed.

Select "Ethernet" in the network configuration settings*1 ⇒ [Device] ⇒ [Properties]

*1 For names of each display, refer to the following.

☞ Page 75 Display content

■[General] tab

The basic information related to the communications of the FX5-ENET/IP is displayed.

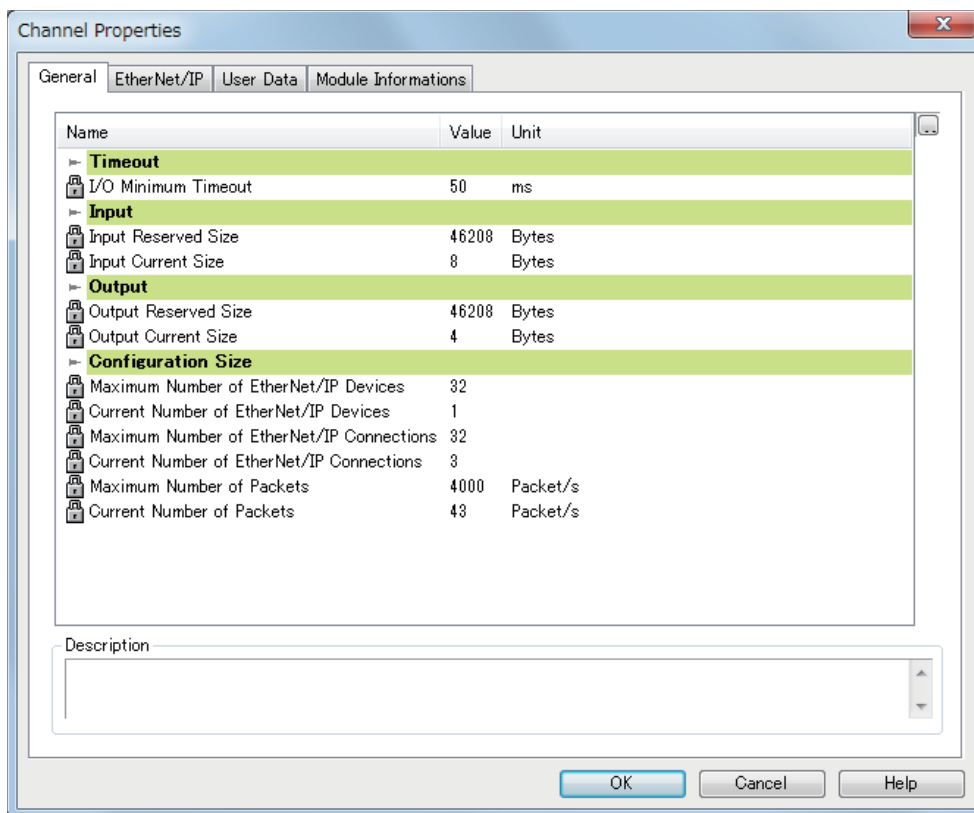

Item	Description	
Timeout	I/O Minimum Timeout	Displays the minimum timeout time that can be set for EtherNet/IP communications. (Unit: ms)
Input	Input Reserved Size	Displays the maximum size of the input data. (Unit: Bytes)
	Input Current Size	Displays the total size of the currently set input data. (Unit: Bytes)
Output	Output Reserved Size	Displays the maximum size of the output data. (Unit: Bytes)
	Output Current Size	Displays the total size of the currently set output data. (Unit: Bytes)
Configuration Size	Maximum Number of EtherNet/IP Devices	Displays the number of EtherNet/IP devices that can be connected to the FX5-ENET/IP.
	Current Number of EtherNet/IP Devices	Displays the number of currently set EtherNet/IP devices.
	Maximum Number of EtherNet/IP Connections	Displays the maximum number of FX5-ENET/IP connections.
	Current Number of EtherNet/IP Connections	Displays the number of currently set connections.
	Maximum Number of Packets	Displays the maximum value of communication processing performance (PPS) of the FX5-ENET/IP. (Unit: Packet/s)
	Current Number of Packets	Displays the communication processing performance (PPS) in the current settings. (Unit: Packet/s)
Description	Displays the description of the selected item.	

■[EtherNet/IP] tab

Configure settings related to the connection between the FX5-ENET/IP and the EtherNet/IP device.

The [EtherNet/IP] tab can be set when "Advanced Mode" is selected. ( Page 58 File)

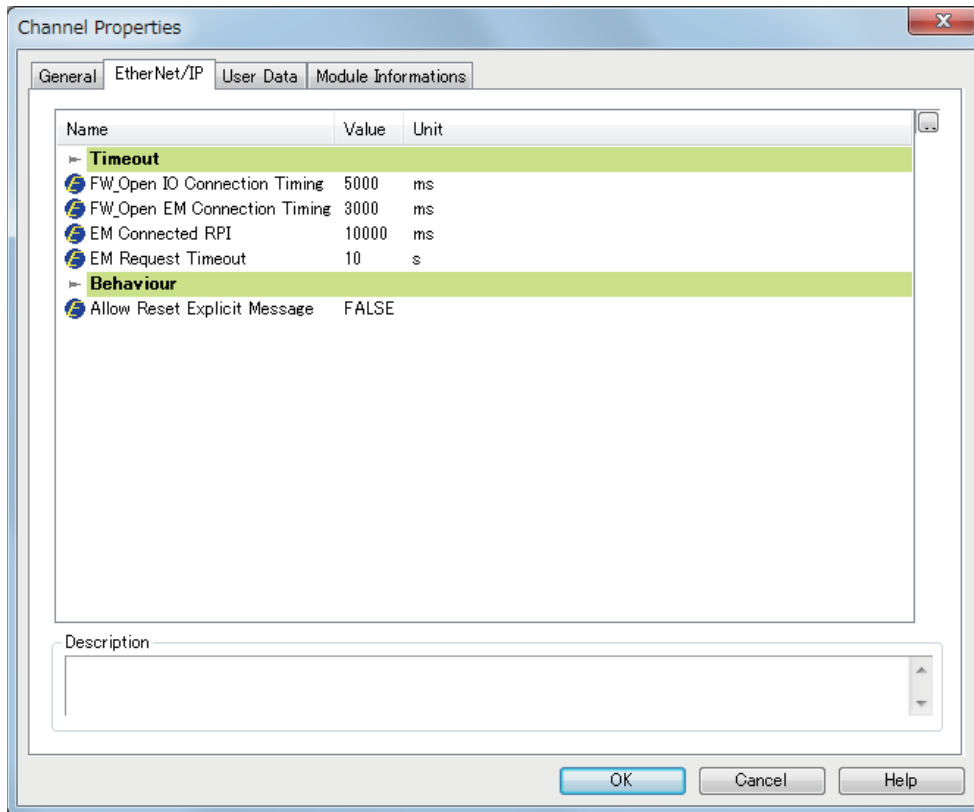

Item	Description	Setting range
Timeout	FW_Open IO Connection Timing	Sets the response waiting time for the connection open request sent from the FX5-ENET/IP to the EtherNet/IP device during Class1 communications. (Unit: ms)
	FW_Open EM Connection Timing	Sets the response waiting time for the connection open request sent from the FX5-ENET/IP to the EtherNet/IP device during Class3 communications. (Unit: ms)
	EM Connected RPI	Sets the communication cycle (RPI) for Class3 communications. (Unit: ms)
	EM Request Timeout	Sets the response waiting time for Class3 communications. (Unit: s)
Behaviour	Allow Reset Explicit Message	Sets the behavior of the FX5-ENET/IP when it receives a reset request message. <ul style="list-style-type: none"> • FALSE: Reset. • TRUE: Do not reset.
Description	Displays the description of the selected item.	—

■[User Data] tab

This tab is not supported in the FX5-ENET/IP.

■[Module Informations] tab

The parameters of the FX5-ENET/IP is displayed.

The [Module Informations] tab can be checked when EtherNet/IP Configuration Tool for FX5-ENET/IP is switched to the online state. ( Page 58 File)

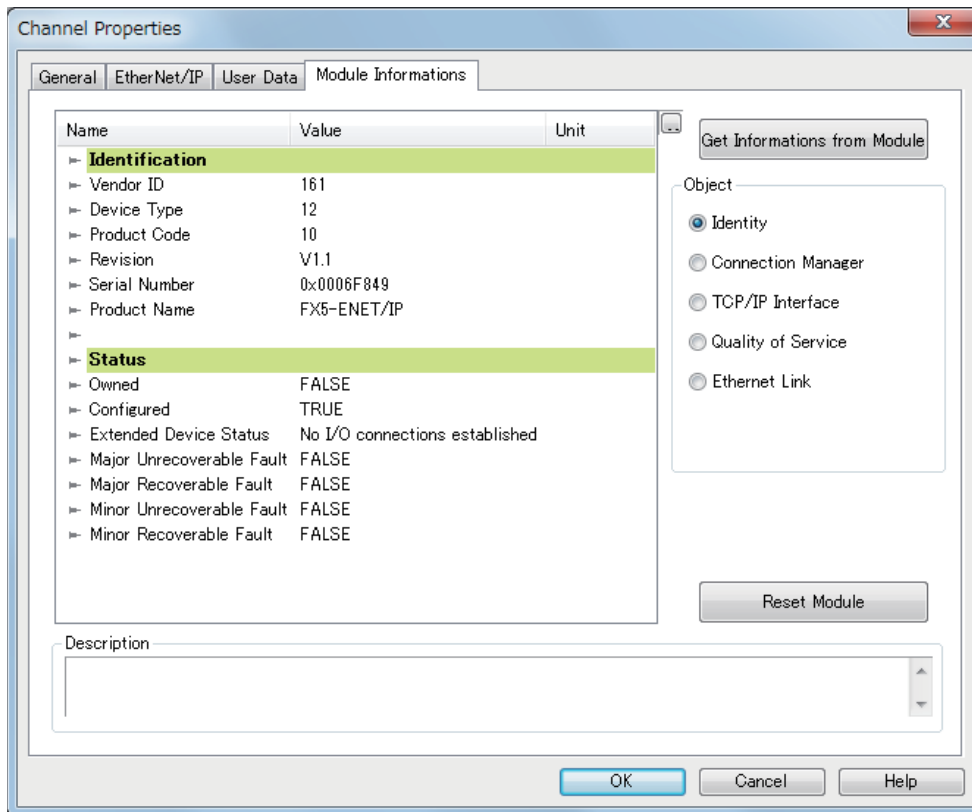

Item	Description
[Get Informations from Module] button	Updates the displayed parameters of the FX5-ENET/IP.
Object* ¹	Selects the parameter type of the FX5-ENET/IP. <ul style="list-style-type: none"> • Identity: General device information • Connection Manager: Information about connection • TCP/IP Interface: Information about TCP/IP network interface • Quality of Service: Information about communication quality • Ethernet Link: Information about link-specific counter and IEEE802.3 communication interface status
[Reset Module] button	Resets the displayed parameters of the FX5-ENET/IP.
Description	Displays the description of the selected item.

*1 This item is displayed when "Advanced Mode" is selected. ( Page 58 File)

• When "Identity" is selected for "Object"

Item		Description
Identification	Vendor ID	Displays the vendor code of the FX5-ENET/IP. (Fixed to 161.)
	Device Type	Displays the module type of the FX5-ENET/IP. (Fixed to 12.)
	Product Code	Displays the product code of the FX5-ENET/IP. (Fixed to 10.)
	Revision	Displays the version of the FX5-ENET/IP.
	Serial Number	Displays the serial number of the FX5-ENET/IP.
	Product Name	Displays the product name of the FX5-ENET/IP. (Fixed to the FX5-ENET/IP.)
Status	Owned	Displays the connection status between the FX5-ENET/IP and the EtherNet/IP device (adapter and scanner). ^{*1} <ul style="list-style-type: none"> • TRUE: The adapter and scanner are connected. • FALSE: The adapter and scanner are not connected.
	Configured	Displays whether the settings of the FX5-ENET/IP were configured with EtherNet/IP Configuration Tool for FX5-ENET/IP. (Excluding TCP/IP-related settings) <ul style="list-style-type: none"> • TRUE: Settings have been configured. • FALSE: Settings have not been configured. (Operations are being performed with the default settings.)
	Extended Device Status	Displays the operation mode of the FX5-ENET/IP. ^{*1} <ul style="list-style-type: none"> • At least one faulted I/O connection: Error occurring on one or more connection • No I/O connections established: No connections established • Major Fault: Major Recoverable Fault or Major Unrecoverable Fault occurring • At least one I/O connection in run mode: One or more connection performing normal communication in RUN mode • At least one I/O connection established, all in idle mode: One or more connection all performing communication in IDLE mode
	Major Unrecoverable Fault	Displays the main major error status of the FX5-ENET/IP. (Unrecoverable error) <ul style="list-style-type: none"> • TRUE: Major error occurring • FALSE: Major error not occurring
	Major Recoverable Fault	Displays the main moderate error and minor error status of the FX5-ENET/IP. (Recoverable error) <ul style="list-style-type: none"> • TRUE: Moderate error or minor error occurring • FALSE: Moderate error or minor error not occurring
	Minor Unrecoverable Fault	Displays the major error status of the FX5-ENET/IP. (Unrecoverable error) <ul style="list-style-type: none"> • FALSE: Major error not occurring (fixed)
	Minor Recoverable Fault	Displays the moderate error and minor error status of the FX5-ENET/IP. (Recoverable error) <ul style="list-style-type: none"> • TRUE: Moderate error or minor error occurring • FALSE: Moderate error or minor error not occurring

*1 The word "connection" described below refers to the "Exclusive Owner" connection. (The bit is not changed by an Input Only or Listen Only connection.)

• When "Connection Manager" is selected for "Object"

Item		Description
Open Counters	Open Requests	Displays the number of open requests received from the connected EtherNet/IP device.
	Format Rejects	Among the open requests received by the FX5-ENET/IP, displays the number of rejected open requests due to message format errors.
	Resource Rejects	Among the open requests received by the FX5-ENET/IP, displays the number of rejected open requests due to insufficient resources.
	Other Rejects	Among the open requests received by the FX5-ENET/IP, displays the number of rejected open requests due to reasons other than message format errors and insufficient resources.
Close Counters	Close Requests	Displays the number of close requests received from the connected EtherNet/IP device.
	Format Rejects	Among the close requests received by the FX5-ENET/IP, displays the number of rejected close requests due to message format errors.
	Other Rejects	Among the close requests received by the FX5-ENET/IP, displays the number of rejected close requests due to reasons other than message format errors.
Others Counters	Connection Timeouts	Displays the number of timeouts that occurred in connections with EtherNet/IP devices.
	Number of Connection	Not supported in the FX5-ENET/IP.

• When "TCP/IP Interface" is selected for "Object"

Item	Description
Status	Displays the presence of settings related to TCP/IP. • 0: No settings present. • 2: Settings present.
Configuration Capability	Displays the settings related to services. • Configuration Settable (fixed)
Startup Configuration	Displays the reference for settings related to TCP/IP on startup.
DNS Enable	Displays whether a DNS server is used. • NO (fixed)
Path to physical Link Object	Displays the path to the physical layer link object.
IP Address	Displays the IP address of the FX5-ENET/IP.
Network Mask	Displays the subnet mask of the FX5-ENET/IP.
Gateway Address	Displays the default gateway of the FX5-ENET/IP.
Primary Name Server Address	Displays the primary DNS server of the FX5-ENET/IP.
Domain Name	Not supported in the FX5-ENET/IP.
Host Name	Not supported in the FX5-ENET/IP.
Safety Network Number	Displays the safety network number.
TTL Value	Displays the TTL (Time-to-Live) value.
Multicast Address Allocation Control	Displays the multicast address allocation method. • 0: Multicast address is allocated with the default algorithm. • 1: Allocation is calculated according to "Number of IP Multicast Addresses Allocated" and "Starting Multicast IP Address".
Number of IP Multicast Addresses Allocated	Displays the number of multicast address to be allocated.
Starting Multicast IP Address	Displays the start address for the multicast addresses to be allocated.

• When "Quality of Service" is selected for "Object"

Item	Description
802.1Q frame Enable	Not supported in the FX5-ENET/IP.
DSCP PTP Event	
DSCP PTP General	
DSCP Urgent	
DSCP Scheduled	
DSCP High	
DSCP Low	
DSCP Explicit	

• When "Ethernet Link" is selected for "Object"

Item	Description	
General	Interface Speed	Displays the communication speed of EtherNet/IP communications.
	Link Status	Displays the link status of EtherNet/IP communications.
	Duplex Mode	Displays the communication method (full-duplex/half-duplex) of EtherNet/IP communications.
	Negotiation Status	Displays the auto-negotiation status. <ul style="list-style-type: none"> • 0: Auto-negotiation being executed. • 1: Auto-negotiation failed and operation in progress with the default communication speed and method. • 2: Communication method detection failed, but communication speed detection succeeded. Operation in progress with the default communication method. • 3: Auto-negotiation completed successfully. • 4: Auto-negotiation unexecuted.
	Manual Setting Requires Reset	Displays the reflection method when communication settings are changed. <ul style="list-style-type: none"> • 0: Immediate reflection after the change • 1: Reflection after the reset of the FX5-ENET/IP
	Local Hardware Fault	Displays the hardware failure status.
	Physical Address	Displays the MAC address of the FX5-ENET/IP.
	802.3 Link Auto-negotiate	Displays whether auto-negotiation is enabled or disabled.
	Forced Duplex Mode	Displays the default communication method set when auto-negotiation is disabled.
	Forced Interface Speed	Displays the default communication speed set when auto-negotiation is disabled.
	Interface Type	Displays the communication interface type.
	Interface State	Displays the communication interface status.
	Admin State	Displays the administration status.
	Interface Label	Displays the communication interface name. (label)
Input	Octets	Displays the length of the received data. (Unit: Octets)
	Ucast Packets	Displays the number of unicast packets received.
	NUcast Packets	Displays the number of non-unicast packets (multicast or broadcast) received.
	Discards	Among the received packets, displays the number of discarded packets.
	Errors	Among the received packets, displays the number of packets that include error information. (Excluding the number of discarded packets)
	In Unknown Protocols	Among the received packets, displays the number of packets with unrecognizable protocols.
Output	Octets	Displays the length of the sent data. (Unit: Octets)
	Ucast Packets	Displays the number of unicast packets sent.
	NUcast Packets	Displays the number of non-unicast packets (multicast or broadcast) sent.
	Discards	Among the sent packets, displays the number of discarded packets.
	Errors	Among the sent packets, displays the number of packets that include error information. (Excluding the number of discarded packets)
Error Counters	Alignment Errors	Displays the number of frames received of which data length is not an octet integral multiple.
	FCS Errors	Displays the number of frames received for which FCS check errors occurred.
	Single Collisions	Displays the number of frames received for which single collisions occurred.
	Multiple Collisions	Displays the number of frames received for which multiple collisions occurred.
	SQE Test Errors	Displays the error count of the SQE test.
	Deferred Transmissions	Displays the number of times that a sending delay occurred.
	Late Collisions	Displays the probability of collisions occurring.
	Excessive Collisions	Displays the number of times that excessive collisions occurred.
	MAC Transmit Errors	Displays the number of MAC frame transmission errors.
	Carrier Sense Errors	Displays the number of errors that occurred during carrier detection.
	Frame Too Long	Displays the receive count of frames that exceeded the maximum size.
	MAC Receive Errors	Displays the number of MAC frame reception errors.

IP address management window

Information such as the IP address of the FX5-ENET/IP is displayed.

Set the address of the FX5-ENET/IP with the module parameters of the GX Works3. ( Page 48 Basic Setting)

 Select the EtherNet/IP module display in the network configuration settings*1 ⇒ [Device] ⇒ [Properties]

*1 For names of each display, refer to the following.

 Page 75 Display content

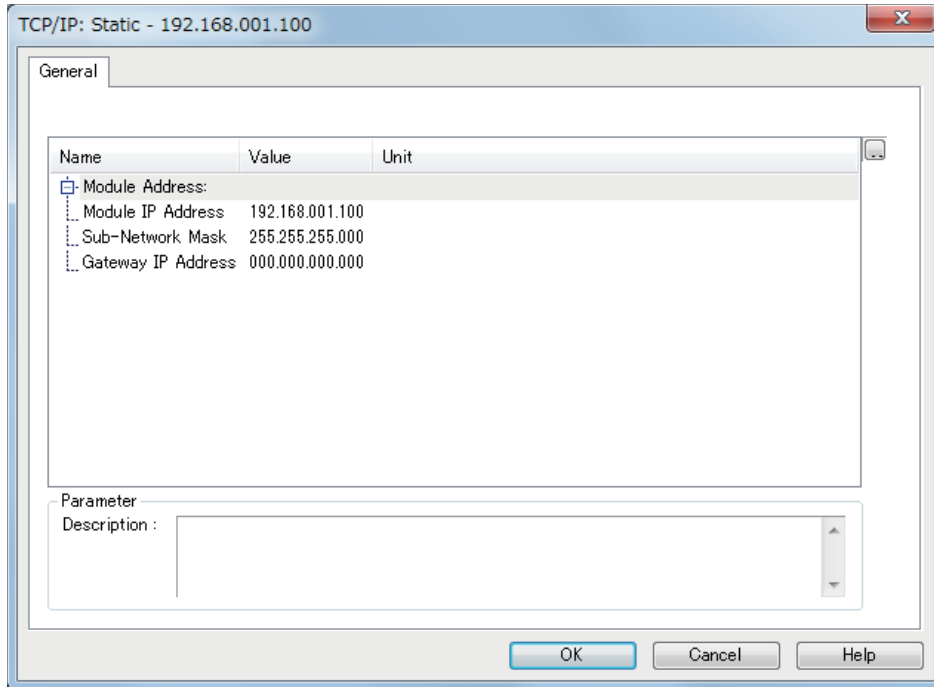

Item		Description
Module Address	Module IP Address	Displays the IP address of the FX5-ENET/IP.
	Sub-Network Mask	Displays the subnet mask of the FX5-ENET/IP.
	Gateway IP Address	Displays the gateway IP address of the FX5-ENET/IP.
Parameter	Description	Displays the description of the selected item.

EtherNet/IP device setting window (Class1 instance communications)

Set the parameters of the EtherNet/IP device used in Class1 instance communications.

Select the EtherNet/IP display in the network configuration settings.*1 ⇒ [Device] ⇒ [Properties]

*1 For names of each display, refer to the following.

Page 75 Display content

Point

Depending on the connected EtherNet/IP device, some tabs may not be displayed in the EtherNet/IP device setting window.

■[General] tab

Set items such as the name and device number of the EtherNet/IP device.

The screenshot shows the configuration window for the 1794-AENT FLEX I/O Ethernet Adapter. The 'General' tab is selected, and the 'Device Designation' section contains the following fields:

- Device Name: DEVICE-A
- Number: 001
- Link Parameters:
- Active Configuration:
- Comment: (empty)

The 'Network Properties' section contains a table with the following data:

Name	Value	Unit
IP Address	192.168.001.001	

The 'Description' field contains the text: IP address of the partner device.

The 'Ping' section contains the following controls:

- Ping button
- Loop checkbox
- Stop on Error checkbox
- Clear button
- Ping Result text area

At the bottom of the window are the OK, Cancel, and Help buttons.

Item	Description	Setting range	
Device Designation	Device Name	Sets the name to use in management with EtherNet/IP Configuration Tool for FX5-ENET/IP. By default, names of EtherNet/IP devices not registered in the network configuration setting are displayed in the form such as "DEVICE-A" and "DEVICE-B".	Up to 50 characters ^{*1} (Default: Refer to the left.)
	Number	Sets the control number of the EtherNet/IP device. The control number that has not been set for EtherNet/IP devices can be selected from the list.	0 to 32 (Default: Minimum value of the control numbers of EtherNet/IP devices that have not been set.)
	Link Parameters	Enables or disables the link between the IP address and the device number of the EtherNet/IP device. • Selected: Enabled • Not selected: Disabled Enable this item to link the device number of the EtherNet/IP device to the fourth octet of the IP address.	• Selected • Not selected (Default: Not selected)
	Active Configuration	Enables or disables the parameters set for the EtherNet/IP device on the FX5-ENET/IP. • Selected: Enabled • Not selected: Disabled Disable this item when the parameters of the EtherNet/IP device need to be deleted from the FX5-ENET/IP with the settings in EtherNet/IP Configuration Tool for FX5-ENET/IP held.	• Selected • Not selected (Default: Selected)
	Comment	Displays the comment input field. Information about the EtherNet/IP device is described with the default setting.	Up to 255 single-byte characters (Default: Varies depending on the EtherNet/IP device)
Network Properties	IP Address	Specifies the IP address of the EtherNet/IP device.	1.0.0.1 to 223.255.255.254 ^{*2} (Default: Current IP address of the EtherNet/IP device)
	Description	Displays the description of the selected item.	—
Ping ^{*3}	[Ping] button	Pings the specified EtherNet/IP device.	—
	Loop	Select this check box to repeatedly ping the device once every 100 ms.	• Selected • Not selected (Default: Not selected)
	Stop on Error	Sets whether to interrupt pingging if an error occurs when the "Loop" check box is selected. • Selected: Pingging will be interrupted if an error occurs. • Not selected: Pingging will continue even if an error occurs.	• Selected • Not selected (Default: Not selected)
	[Clear] button	Deletes the content of "Ping Result".	—
	Ping Result	Displays the result of pingging.	—

*1 Characters from A to Z, numbers from 0 to 9, "." (dot), "-" (hyphen), and "_" (underscore) can be used. For the first character of a name, only characters from A to Z can be used.

*2 Cannot be set to a value from 127.0.0.0 to 127.255.255.255.

*3 Can be selected when EtherNet/IP Configuration Tool for FX5-ENET/IP is switched to the online state. (📄 Page 58 File)

Point

When an EtherNet/IP device has been added by "Network Detection", its IP address is registered automatically. When an EtherNet/IP device has been added from "Device Library", manually enter its IP address.

For the operations on "Network Detection" and "Device Library", refer to the following.

- 📄 Page 69 Network Detection
- 📄 Page 67 Device Library

■[Chassis] tab

Set the modules to be mounted in each slot for EtherNet/IP devices to which modules can be mounted.

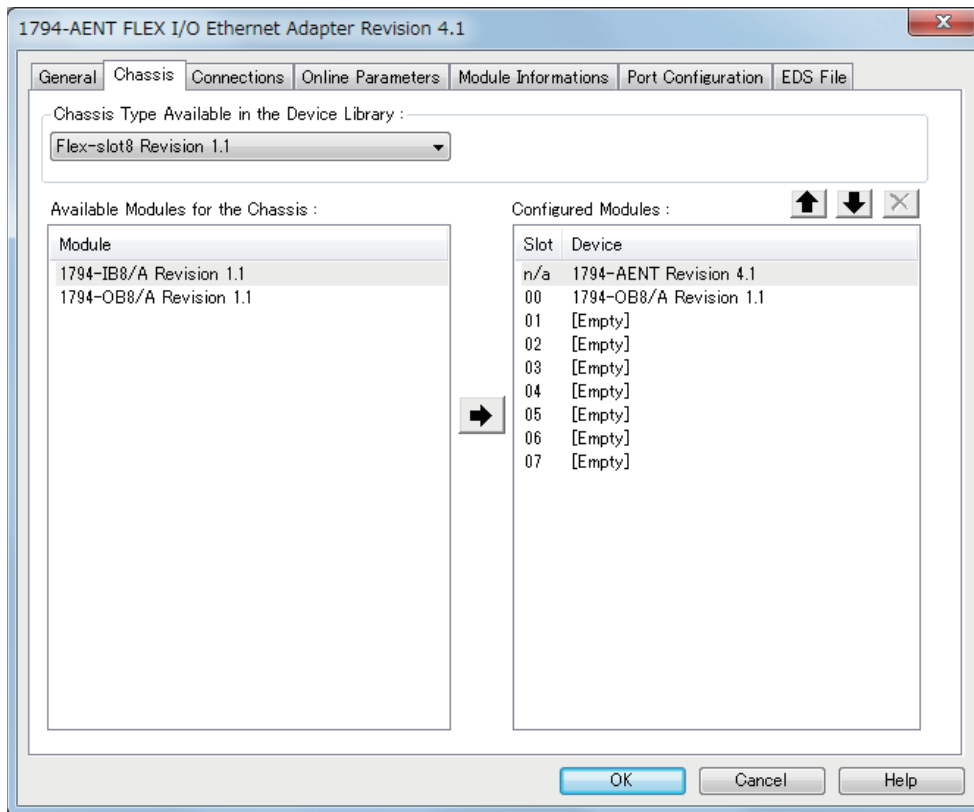

Item		Description
Chassis Type Available in the Device Library	[Set Chassis Size in the Module] button	Selects the number of slots to which modules can be mounted. For the setting range and the default value, refer to the manuals of the EtherNet/IP device.
	[Get Chassis Size in the Module] button	
Available Modules for the Chassis		Displays a list of the modules that can be mounted to the EtherNet/IP device. This content varies depending on the EtherNet/IP device. Select a module and click the [→] button to add the module to the list of "Configured Modules". (When the module is added to the list by a drag-and-drop operation, it can be added to a desired slot.)
Configured Modules		Sets the modules of the EtherNet/IP device for each "Slot" number. Select a module and edit it with the following buttons. <ul style="list-style-type: none"> • [↑] button: Moves the selected module to the upper slot. • [↓] button: Moves the selected module to the lower slot. • [×] button: Deletes the selected module.

■[Connections] tab

Set items such as the communication content when the connection with the EtherNet/IP device is established.

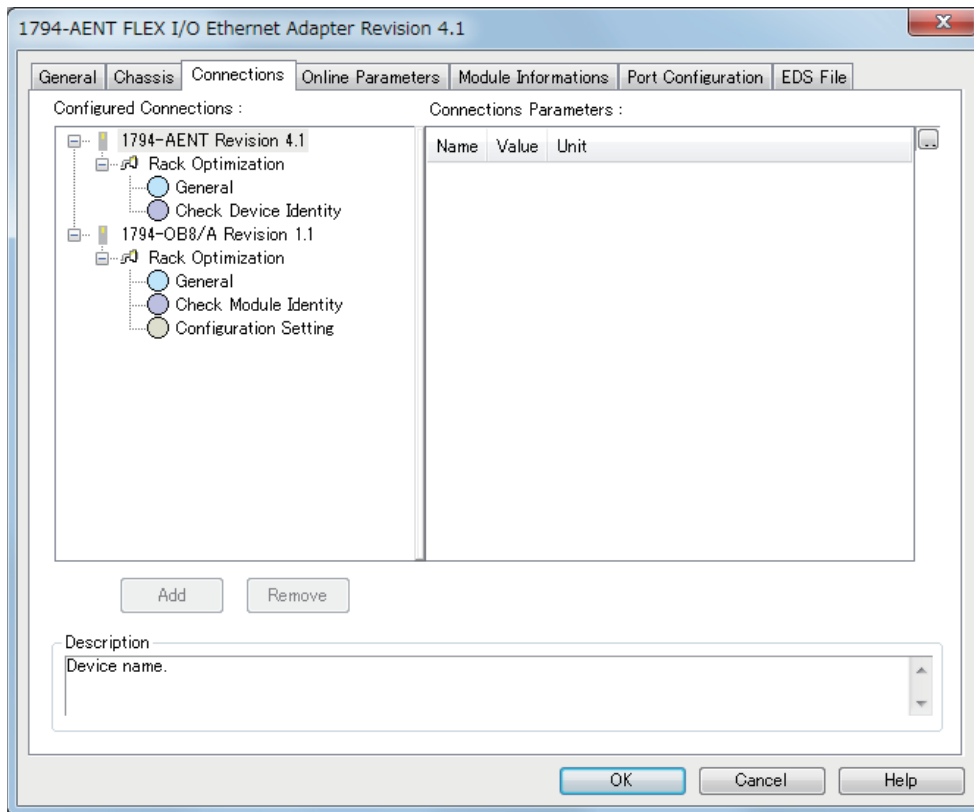

Item	Description
Configured Connections	Displays the connection status of the devices or modules of the EtherNet/IP device.
Connection Parameters	Displays the parameters of the EtherNet/IP device selected under "Configured Connections". <ul style="list-style-type: none"> • General: The parameters are set the connection to the EtherNet/IP device. • Check Device Identity: The parameters are verified the settings against the actual EtherNet/IP device to check whether they match. • Configuration Setting: The parameters are displayed the settings defined in the EDS file for each EtherNet/IP device. For details, refer to the manuals of the EtherNet/IP device.
[Add] button	Displays the following window when clicked with a device or module of an EtherNet/IP device selected. <div data-bbox="603 1350 1109 1574" data-label="Image"> </div>
[Remove] button	Deletes the selected device or module of the EtherNet/IP device when clicked.
Description	Displays the description of the selected item.

• "General" window

Name	Value	Unit
Connection No.	1	
Time-out Multiplier	x4	
Input - T→O		
Input Size	0	bytes
Input Mode	Point to Point	
Input Type	Fixed	
Priority	Scheduled	
Trigger Type	Cyclic	
Request Packet Interval (RPI)	30	ms
Output - O→T		
Output Size	8	bytes
Output Mode	Point to Point	
Output Type	Fixed	
Priority	Scheduled	
Request Packet Interval (RPI)	100	ms

Item	Description	Setting range	
Connection Bit Health Offset	Displays the connection number of the EtherNet/IP device. Connection numbers of EtherNet/IP devices are assigned from 1 in the order in which they were added.	—	
Time-out Multiplier	Specifies the monitoring time of the send/receive timeout as an RPI multiple. (Monitoring time of send/receive timeout = "Request Packet Interval (RPI)" × "Time-out Multiplier") Set the monitoring time of send/receive timeout to 4294967ms or below. • When "Time-out Multiplier" is set to "x4", set "Request Packet Interval (RPI)" to "60000" or below. • When "Time-out Multiplier" is set to "x512", set "Request Packet Interval (RPI)" to "8388" or below.	<ul style="list-style-type: none"> • × 4 • × 8 • × 16 • × 32 • × 64 • × 128 • × 256 • × 512 (Default: Varies depending on the EtherNet/IP device)	
Input -T->O	Input Size	Specifies the size of the input data. (Unit: Bytes) ¹	0 to 1444 (Default: Varies depending on the EtherNet/IP device)
	Input Mode	Specifies the target to read the input data from. • Point to Point: Unicast (one to one) communications are performed. • Multicast: Multicast (one to many) communications are performed. • Null: Communications are not performed.	<ul style="list-style-type: none"> • Point to Point • Multicast • Null (Default: Varies depending on the EtherNet/IP device)
	Input Type	Specifies the input type (variable or fixed) according to the size of the input data. • Variable: Communications are performed with a variable size. ² • Fixed: Communications are performed with a fixed size.	<ul style="list-style-type: none"> • Variable • Fixed (Default: Varies depending on the EtherNet/IP device)
	Priority	Specifies the priority of the communication packet for the currently set connection. • High: Processing is performed with high priority. • Low: Priority is given to the processing of connections set to "High". • Scheduled: Packets are processed in the receiving order regardless of priority.	<ul style="list-style-type: none"> • High • Low • Schedule (Default: Varies depending on the EtherNet/IP device)
	Trigger Type	Specifies the trigger type (reading timing) of the input data. • Cyclic: Triggers are executed periodically according to the "RPI" setting value. • Application: Triggers are executed with arbitrary timing according. • Change of State: Triggers are executed at a given timing according.	<ul style="list-style-type: none"> • Cyclic • Application • Change of State (Default: Varies depending on the EtherNet/IP device)
	Inhibit Time Mode	Specifies the method to manage the inhibit time when "Trigger Type" is set to "Change of State". • Default: A quarter of RPI is specified as the inhibit time. • Un-Activated: No inhibit time is specified. • Custom: Time specified in "Inhibit time" is specified as the inhibit time.	<ul style="list-style-type: none"> • Default • Un-Activated • Custom (Default: Varies depending on the EtherNet/IP device)
	Inhibit time	Specifies the inhibit time when "Inhibit Time Mode" is set to "Custom". (Unit: ms)	1 to 255 (Default: Varies depending on the EtherNet/IP device)
	Request Packet Interval(RPI)	Specifies the communication cycle. (Unit: ms)	2 to 60000 (Default: Varies depending on the EtherNet/IP device)

Item	Description	Setting range
Output-O->T	Output Size	Specifies the size of the output data. (Unit: Bytes) ^{*1} 0 to 1444 (Default: Varies depending on the EtherNet/IP device)
	Output Mode	Specifies the target to which the output data is written. <ul style="list-style-type: none"> Point to Point: Unicast (one to one) communications are performed. Multicast: Multicast (one to many) communications are performed. Null: Communications are not performed. • Point to Point • Multicast • Null (Default: Varies depending on the EtherNet/IP device)
	Output Type	Specifies the output type (variable or fixed) according to the size of the output data. ^{*3} <ul style="list-style-type: none"> Variable: Communications are performed with a variable size.^{*2} Fixed: Communications are performed with a fixed size. • Variable • Fixed (Default: Varies depending on the EtherNet/IP device)
	Priority	Specifies the priority of the communication packet for the currently set connection. <ul style="list-style-type: none"> High: Processing is performed with high priority. Low: Priority is given to the processing of connections set to "High". Scheduled: Packets are processed in the receiving order regardless of priority. • High • Low • Schedule (Default: Varies depending on the EtherNet/IP device)
	Request Packet Interval(RPI)	Specifies the communication cycle. (Unit: ms) 2 to 60000 (Default: 100 ms ^{*4})

*1 Large Forward Open must be available for the EtherNet/IP device when this item is specified to 505 bytes or more.
For details, refer to the manuals of the EtherNet/IP device.

*2 Variable connections must be available for the EtherNet/IP device when this item is specified to "Variable".
For details, refer to the manuals of the EtherNet/IP device.

*3 Regardless of this setting, the FX5-ENET/IP sends data with the size specified with "Output Size".

*4 If the available setting range of RPI for the EtherNet/IP device is 100 ms or less, when the default value of 100 ms is set, an error may occur while saving the project. If an error occurs, change the setting value so that it is in the available setting range of the EtherNet/IP device. For the setting range of RPI, refer to the manual of the EtherNet/IP device.

• "Check Device Identity" window

Name	Value	Unit
▶ Check Identity	Custom	
▶ Compatible Mode	True	
▶ Minor Version	Compatible	
▶ Major Version	Compatible	
▶ Product Code	Compatible	
▶ Product Type	Compatible	
▶ Product Vendor	Compatible	

Item	Description	Setting range
Check Identity	Specifies the policy of the consistency check. The connection is disconnected if the check results in a mismatch. <ul style="list-style-type: none"> • Disable: The check is not performed. • Must Match Exactly: Checks whether all items match exactly. • Must be Compatible: Checks all items and judges there to be no problem if the items are compatible. • Custom: The check items are set with "Compatible Mode" and the subsequent items. • None: The check is not performed. (For EtherNet/IP devices on which check processing is not available) 	<ul style="list-style-type: none"> • Disable • Must Match Exactly • Must be Compatible • Custom • None (Default: Disable)
Compatible Mode ^{*1}	Specifies the compatibility check. <ul style="list-style-type: none"> • True: "Minor Version" and subsequent items must be compatible. • False: "Minor Version" and subsequent items must match exactly. 	<ul style="list-style-type: none"> • True • False (Default: True)
Minor Version ^{*1}	Specifies the minor version check. <ul style="list-style-type: none"> • Compatible: The check is performed. • Not Checked: The check is not performed. 	<ul style="list-style-type: none"> • Compatible • Not Checked (Default: Compatible)
Major Version ^{*1}	Specifies the major version check. <ul style="list-style-type: none"> • Compatible: The check is performed. • Not Checked: The check is not performed. 	<ul style="list-style-type: none"> • Compatible • Not Checked (Default: Compatible)
Product Code ^{*1}	Specifies the product code check. <ul style="list-style-type: none"> • Compatible: The check is performed. • Not Checked: The check is not performed. 	<ul style="list-style-type: none"> • Compatible • Not Checked (Default: Compatible)
Product Type ^{*1}	Specifies the product type check. <ul style="list-style-type: none"> • Compatible: The check is performed. • Not Checked: The check is not performed. 	<ul style="list-style-type: none"> • Compatible • Not Checked (Default: Compatible)
Product Vendor ^{*1}	Specifies the vendor code check. <ul style="list-style-type: none"> • Compatible: The check is performed. • Not Checked: The check is not performed. 	<ul style="list-style-type: none"> • Compatible • Not Checked (Default: Compatible)

*1 This item is displayed when "Custom" is specified for "Check Identity".

■[Online Parameters] tab

Read and write information such as the error information in EDS files.

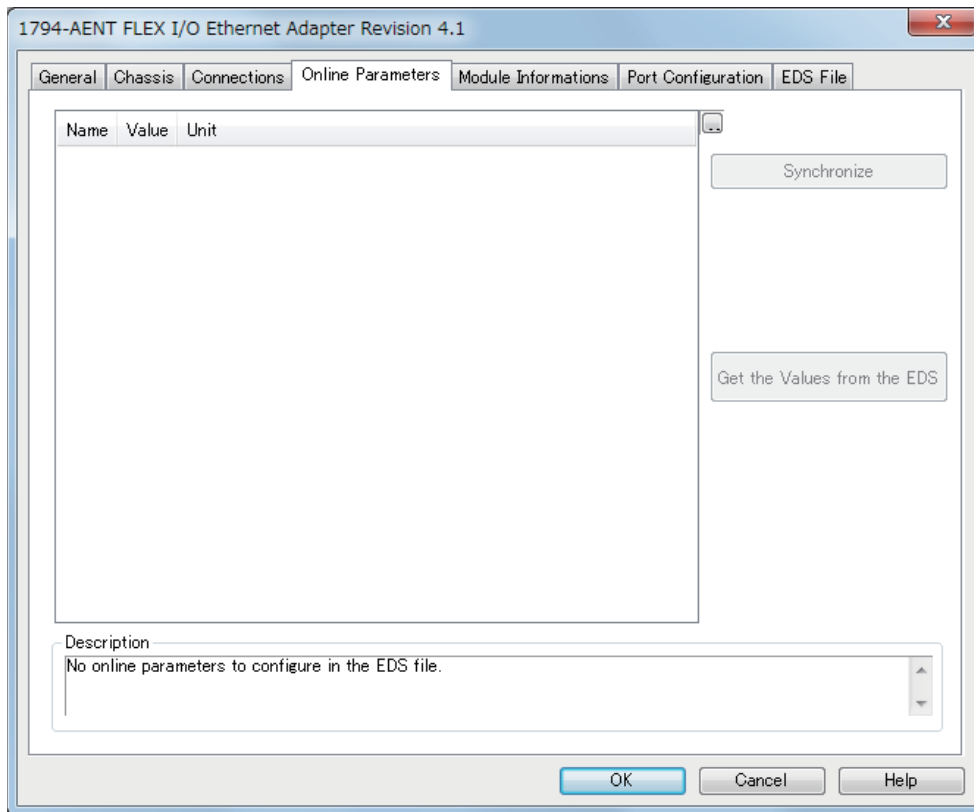

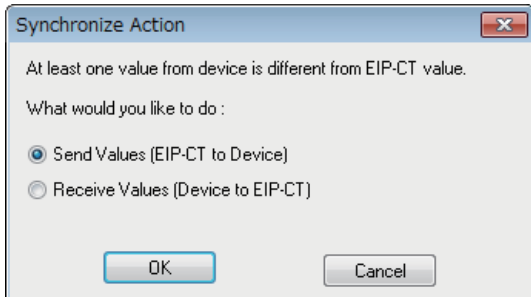
Item	Description
[Synchronize] button	<p>Displays the following window for reading and writing values displayed on the [Online Parameters] tab for the EtherNet/IP device.</p>  <ul style="list-style-type: none"> • Send Values (EIP-CT to Device): Writes the values displayed on the [Online Parameters] tab to the EtherNet/IP device. • Receive Values (Device to EIP-CT): Reads the values displayed on the [Online Parameters] tab from the EtherNet/IP device.
[Get the Values from the EDS] button	Initializes the values displayed on the [Online Parameters] tab (sets the values to the default values in the EDS file).
Description	Displays the description of the selected item.

■[Module Informations] tab

The parameters of the EtherNet/IP device are displayed.

Items in this window can be used when EtherNet/IP Configuration Tool for FX5-ENET/IP is switched to the online state.

( Page 58 File)

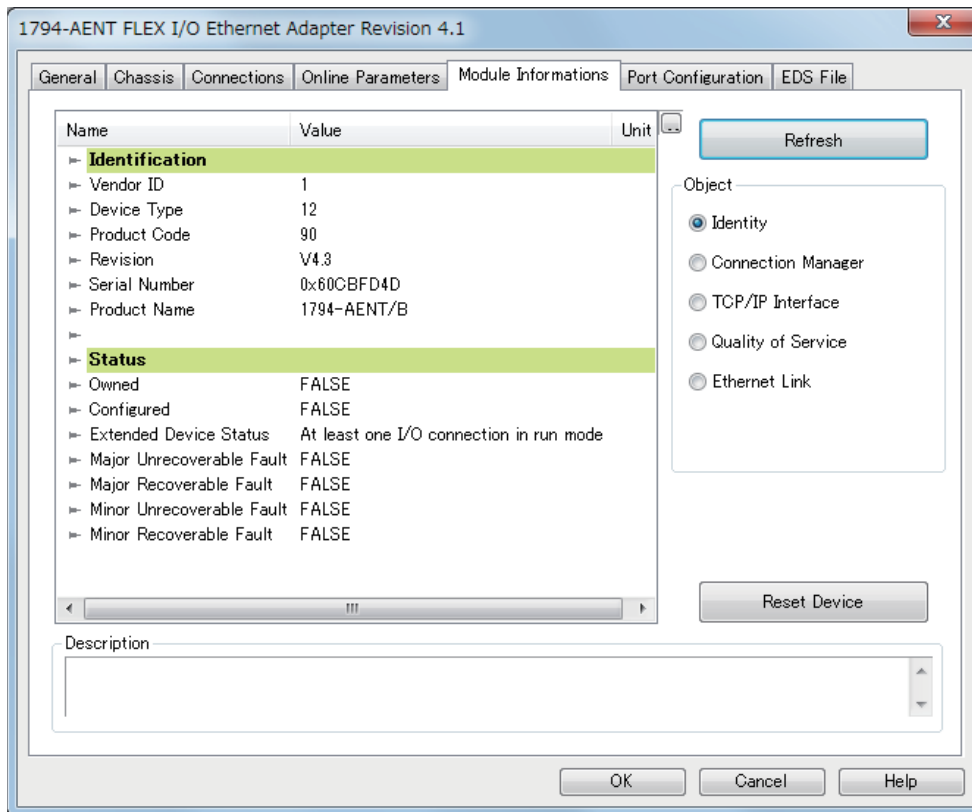

Item	Description
[Refresh] button	Updates the displayed parameters of the EtherNet/IP device. All the initial values are displayed as "###". Clicking the [Refresh] button acquires the information of the item selected in "Object".
Object* ¹	Selects the type of values to read from the EtherNet/IP device. <ul style="list-style-type: none"> • Identity: General device information • Connection Manager: Information about connection • TCP/IP Interface: Information about TCP/IP network interface • Quality of Service: Information about communication quality • Ethernet Link: Information about link-specific counter and IEEE802.3 communication interface status
[Reset Device] button	Resets the displayed parameters of the EtherNet/IP device.
Description	Displays the description of the selected item.

*¹ This item is displayed when "Advanced Mode" is selected. ( Page 58 File)

■[Port Configuration] tab

Read and write the connection status of the EtherNet/IP device.

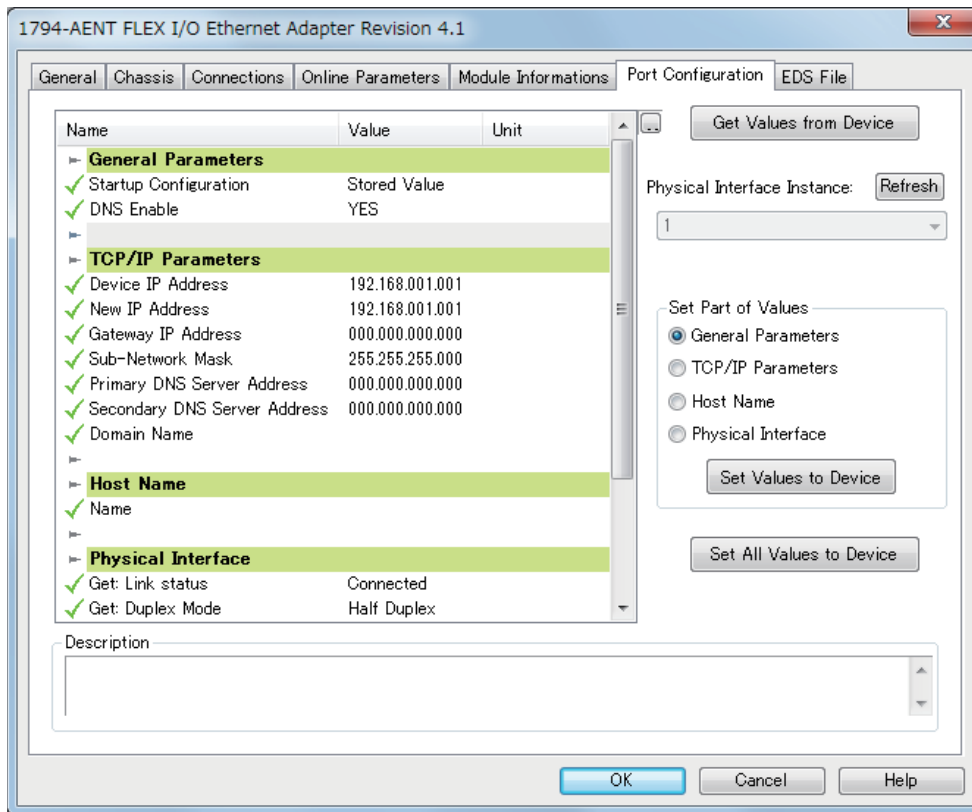

Item	Description
[Get Values from Device] button	Reads and displays the connection status of the EtherNet/IP device.
Physical Interface Instance	Specifies the port number from the list when the EtherNet/IP device is configured with multiple ports.
[Refresh] button	Updates the port number of the "Physical Interface Instance".
Set Part of Values	Selects the items of the values to write to the EtherNet/IP device from the following. <ul style="list-style-type: none"> • General Parameters: Basic parameter settings • TCP/IP Parameters: TCP/IP parameter settings • Host Name: Host name settings • Physical Interface: Physical interface settings
[Set Values to Device] button	Writes the values of the items selected with "Set Part of Values" to the EtherNet/IP device.
[Set All Values to Device] button	Writes all the values of the displayed connection status to the EtherNet/IP device.
Description	Displays the description of the selected item.

■[Diagnostic] tab

The connection status of the EtherNet/IP device is displayed.

This tab can be used when diagnostic mode is enabled. (☞ Page 118 Network diagnostics of EtherNet/IP Configuration Tool for FX5-ENET/IP)

Point

To display this content, 'EtherNet/IP communication start request' (Un\G37.b0) must be turned off and on and 'EtherNet/IP communication in process' (Un\G35.b0) must be in the ON state.

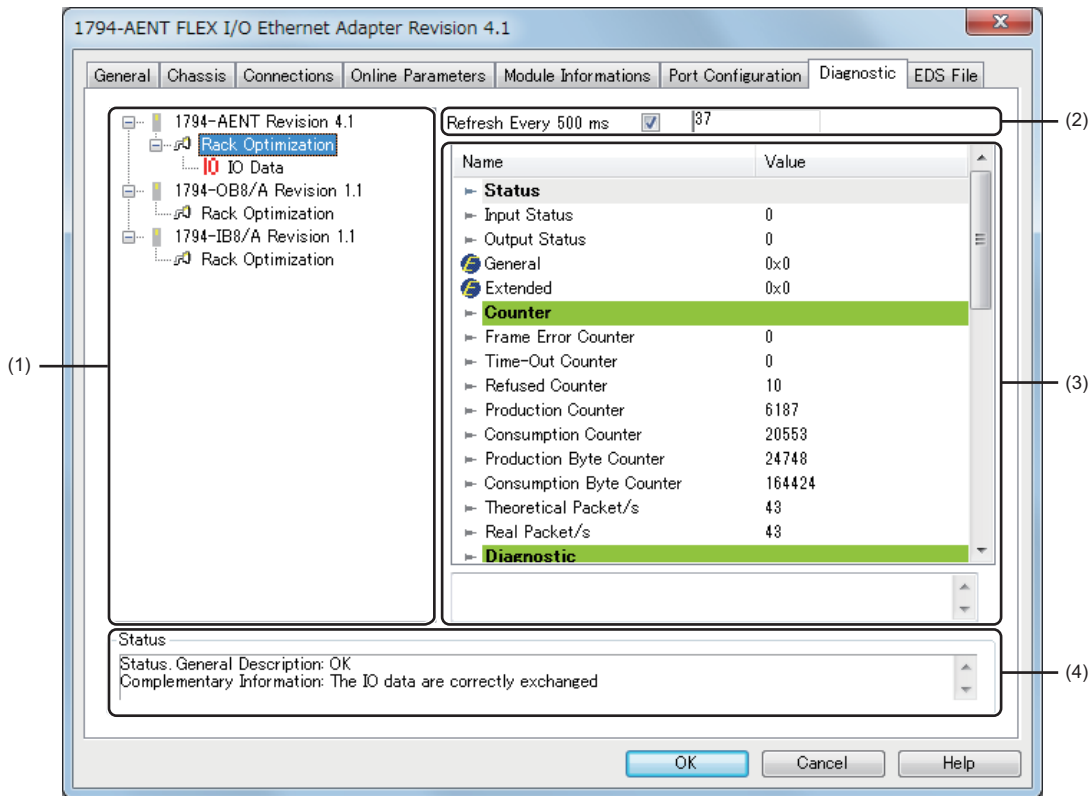

No.	Item	Description	Setting range
(1)	Connection list	Displays the names of the connections set on the [Connections] tab. Diagnostic information is displayed in the connection information when "Monitor Data And External Input" is selected. I/O data is displayed in the connection information when "IO Data" is selected.	—
(2)	Refresh Every	Connection information content is updated at 500 ms intervals when this check box is selected. The update count is incremented each time the information is updated.	<ul style="list-style-type: none"> • Selected • Not selected (Default: Selected)
(3)	Connection information	Displays the diagnostic information and I/O data.	—
(4)	Status	Displays the connection status.	—

• Diagnostic information window

Name	Value
▶ Status	
▶ Input Status	0
▶ Output Status	0
▶ General	0x0
▶ Extended	0x0
▶ Counter	
▶ Frame Error Counter	0
▶ Time-Out Counter	0
▶ Refused Counter	10
▶ Production Counter	6187
▶ Consumption Counter	20553
▶ Production Byte Counter	24748
▶ Consumption Byte Counter	164424
▶ Theoretical Packet/s	43
▶ Real Packet/s	43
▶ Diagnostic	

Item	Description	
Status	Input Status	Displays the internal status code of the input connection.
	Output Status	Displays the internal status code of the output connection.
	General ²	Displays the CIP general status code. ^{*1}
	Extended ²	Displays the CIP extended status code. ^{*1}
Counter	Frame Error Counter	Displays the number of frames that could not be sent/received.
	Time-Out Counter	Displays the number of connection timeouts.
	Refused Counter	Displays the number of connection disconnections.
	Production Counter	Displays the transmission count.
	Consumption Counter	Displays the receive count.
	Production Byte Counter	Displays the number of transmission bytes.
	Consumption Byte Counter	Displays the number of receive bytes.
	Theoretical Packet/s	Displays the number of send/receive packets per second (theoretical value).
	Real Packet/s	Displays the number of send/receive packets per second (process value).
Diagnostic	Production Connection ID	Displays the transmission connection ID for the EtherNet/IP device of the requested connection. ^{*1}
	Consumption Connection ID	Displays the receive connection ID for the EtherNet/IP device of the requested connection. ^{*1}
	O->T API (μs)	Displays the originator to target API value for the EtherNet/IP device of the requested connection. ^{*1}
	T->O API (μs)	Displays the target to originator API value for the EtherNet/IP device of the requested connection. ^{*1}
	O->T RPI (μs)	Displays the originator to target RPI value for the EtherNet/IP device of the requested connection. ^{*1}
	T->O RPI (μs)	Displays the target to originator RPI value for the EtherNet/IP device of the requested connection. ^{*1}
	O->T Net Parameters	Displays the originator to target network parameters for the EtherNet/IP device of the requested connection. ^{*1}
	T->O Net Parameters	Displays the target to originator network parameters for the EtherNet/IP device of the requested connection. ^{*1}
	Originator Connection Serial Number	Displays the connection serial number of the originator. ^{*1}
	Originator Vendor Id	Displays the vendor code of the originator. ^{*1}
	Originator Serial Number	Displays the serial number of the originator. ^{*1}
Send Socket Diagnostic ^{*2}	Socket ID	Displays the socket ID of the send connection.
	Remote IP Address	Displays the IP address of the EtherNet/IP device.
	Remote Port	Displays the port number of the EtherNet/IP device.
	Local IP Address	Displays the IP address of the FX5-ENET/IP. • Multicast: Displays the multicast address. • Unicast: Displays 0.0.0.0.
	Local IP Port	Displays the port number of the FX5-ENET/IP.
Receive Socket Diagnostic ^{*2}	Socket ID	Fixed to 0
	Remote IP Address	Displays the IP address of the EtherNet/IP device.
	Remote Port	Fixed to 0
	Local IP Address	Displays the IP address of the FX5-ENET/IP.
	Local IP Port	Fixed to 0

*1 For details on the displayed content, refer to the EtherNet/IP specifications issued by ODVA (www.odva.org).

*2 This item is displayed when "Advanced Mode" is selected. (Page 58 File)

- I/O data window

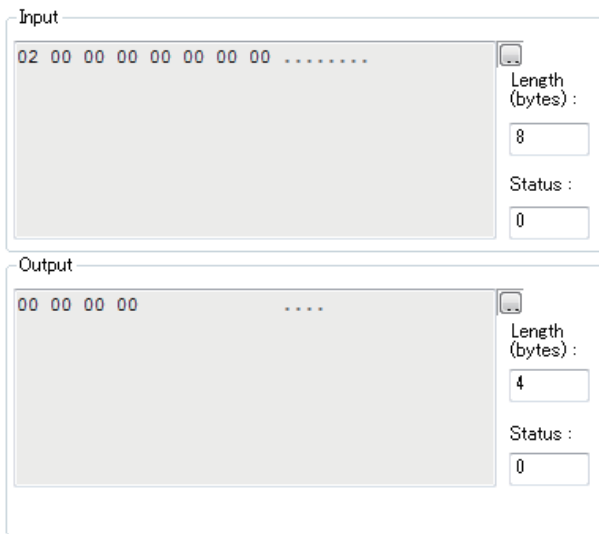

Item		Description
Input	[.] button	Changes the display format of the input data.
	Length(bytes)	Displays the size of the input data. (Unit: Bytes)
	Status	Displays the Status value of the input connection.
Output	[.] button	Changes the display format of the output data.
	Length(bytes)	Displays the size of the output data. (Unit: Bytes)
	Status	Displays the Status value of the output connection.

Point

I/O data of connections that exceed 1400 bytes is not displayed in the I/O data window.

To check I/O data of connections that exceed 1400 bytes, refer to the following.

- 'Class1 communications input data area' (Un\G12000 to Un\G35999)
- 'Class1 communications output data area' (Un\G60000 to Un\G83999)

- Status value

The following table lists the values of the "Input Status", "Output Status", and "Status" displayed in the diagnostic information window and I/O data window.

When the FX5-ENET/IP is scanner	
Status value	Description
0	EtherNet/IP communications are being performed normally.
33	A timeout has occurred.
53	An Idle notification has been received from the EtherNet/IP device.
54	EtherNet/IP communication connection has been established and no communications are performed.
58	An EtherNet/IP communication error (TCP error) has occurred.
65	An EtherNet/IP communication error (CIP error) has occurred.
68	EtherNet/IP communication connection processing is in progress.
70	An EtherNet/IP communication error (CIP error) has occurred.
77	EtherNet/IP communication is stopping.

When the FX5-ENET/IP is adapter	
Status value	Description
0	EtherNet/IP communications are being performed normally.
33	An EtherNet/IP communication error is occurring.
53	An Idle notification has been received from the EtherNet/IP device.
54	EtherNet/IP communication connection has been established and no communications are performed.

■[EDS File] tab

The EDS file information is displayed.

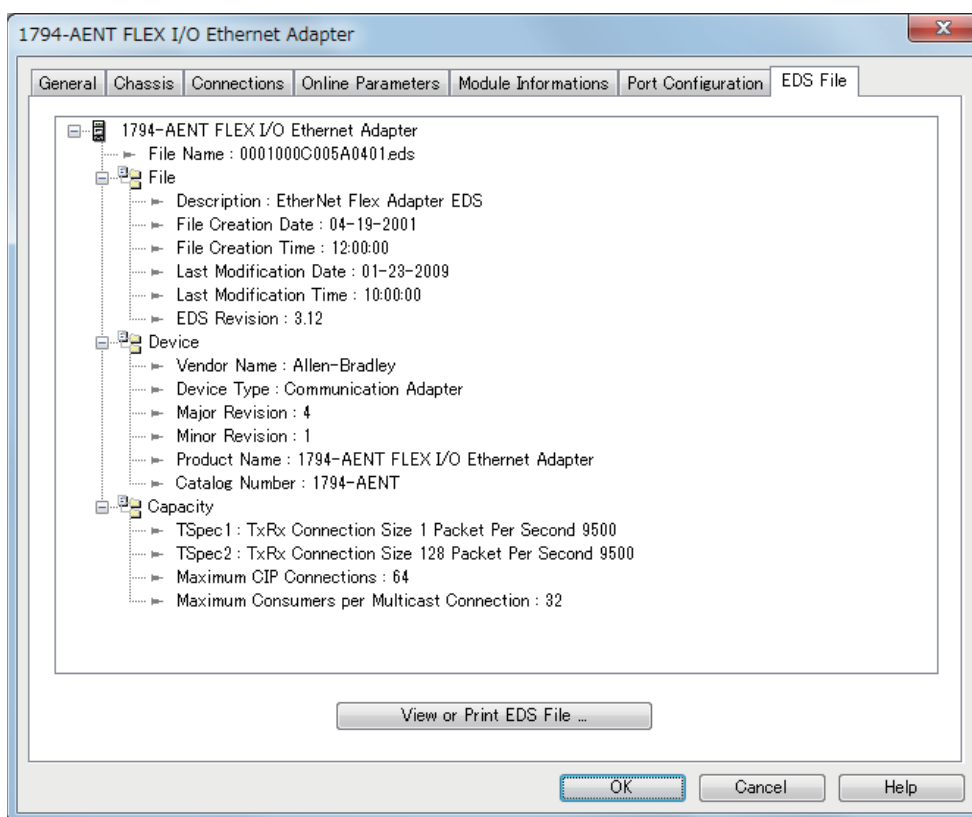

Item	Description
[View or Print EDS File] button	Displays EDS file information in the text format. This button is the same as the [View or Print EDS File] button for the EDS information of an EtherNet/IP device in "Device Library". (Page 68 EDS file information)

Setting Target Instance

If the FX5-ENET/IP is set as the target of the EtherNet/IP communication, select "Target (Class1 Instance)", and drag and drop it to the Network configuration setting.

Item		Description	Setting range
Device Designation	Device Name	Sets the name to use in management with EtherNet/IP Configuration Tool for FX5-ENET/IP. By default, names of EtherNet/IP devices not registered in the network configuration setting are displayed in the form such as "DEVICE-A" and "DEVICE-B".	Up to 50 characters ^{*1} (Default: Refer to the left.)
	Number	Sets the control number of the EtherNet/IP device. The control number that has not been set for EtherNet/IP devices can be selected from the list.	000 to 255 (Default: Minimum value of the control numbers of EtherNet/IP devices that have not been set.)
	Active Configuration	Enables or disables the parameters set for the EtherNet/IP device on the FX5-ENET/IP. • Selected: Enabled • Not selected: Disabled Disable this item when the parameters of the EtherNet/IP device need to be deleted from the FX5-ENET/IP with the settings in EtherNet/IP Configuration Tool for FX5-ENET/IP held.	• Selected • Not selected (Default: Selected)
	Comment	Displays the comment input field.	Up to 255 single-byte characters (Default: Blank)
	Connection No	Displays the connection number of the EtherNet/IP device. Connection numbers of EtherNet/IP devices are assigned from 1 in the order in which they were added.	—
Assembly Instance(T->O)	Instance	Specifies the instance number used in Class1 instance communications (T->O).	100 to 199 (Default: 101)
	Size	Specifies the data size of used in Class1 instance communications (Unit: byte).	1 to 1444 (Default: 256)
Assembly Instance(O->T)	Instance	Specifies the instance number used in Class1 instance communications (O->T).	100 to 199 (Default: 102)
	Size	Specifies the data size of used in Class1 instance communications (Unit: byte).	1 to 1444 (Default: 256)

*1 Characters from A to Z, numbers from 0 to 9, "." (dot), "-" (hyphen), and "_" (underscore) can be used. For the first character of a name, only characters from A to Z can be used.

Operation information list

This list displays information such as the operations performed in EtherNet/IP Configuration Tool for FX5-ENET/IP and error messages.

Date / Time	Level	Event
10/18/18 17:59:58	Information	File 0001000700350101.eds. 1794 - 8 Point 24V DC Output, Source Revision 1.1. Connection Redundant Owner: transport type not authorized or not filled.
10/18/18 18:00:04	Information	Configuration offline.

Output Message View

"Output Message View Configuration" window

Set the information to be displayed in the operation information list.

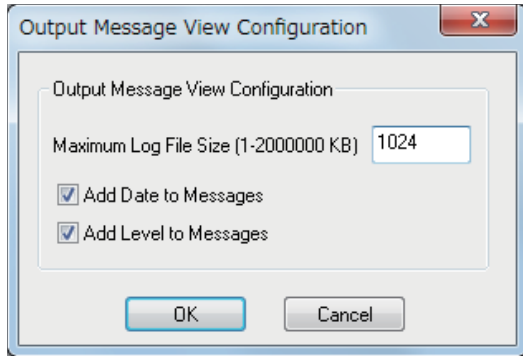

 [File] ⇒ [Message View] ⇒ [Configuration]



Item	Description	Setting range
Maximum Log File Size	Sets the maximum size of a log file. (Unit: KB)	1 to 2000000 (Default: 1024)
Add Date to Messages	Displays the date as a column item in the operation information list.	<ul style="list-style-type: none"> • Not selected • Selected (Default: Selected)
Add Level to Messages	Displays the classification as a column item in the operation information list.	<ul style="list-style-type: none"> • Not selected • Selected (Default: Selected)

8.2 Procedure for Registering EtherNet/IP Devices

This section describes the procedure for registering EtherNet/IP devices to the EtherNet/IP communication settings. The following two methods can be used to register EtherNet/IP devices.

- Configuring settings online ( Page 103 Configuring settings online)
- Configuring settings offline ( Page 103 Configuring settings offline)

Adding the EDS file

Follow the EDS Management wizard to add EtherNet/IP devices to "Device Library".

1. Open the "EDS Management" window.

 [Library]⇒[Add]

2. Click the [Next] button in the "EDS Management" window.

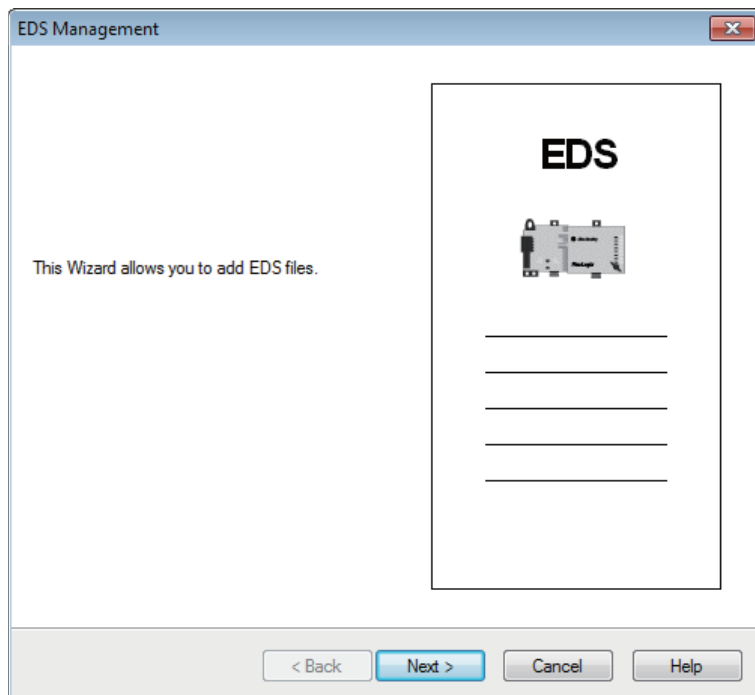

3. Select EDS files to add and click the [Next] button.

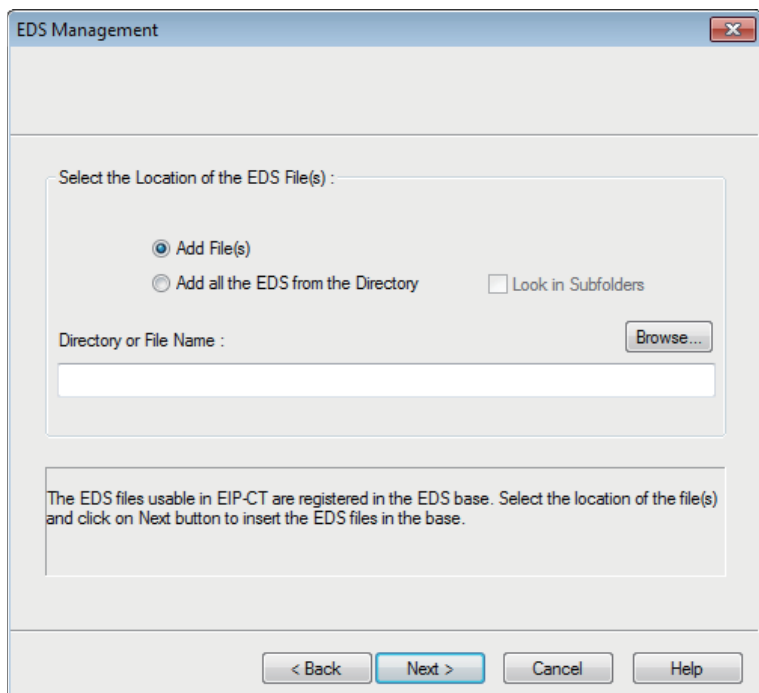

Item	Description	Setting range
Add File(s)	Select this item to add the selected EDS files. (Multiple EDS files can be added at a time.) Click the [Browse] button and select EDS files.	<ul style="list-style-type: none"> • Selected • Not selected (Default: Selected)
Add all the EDS from the Directory	Select this item to add all EDS files in the selected folder. Click the [Browse] button to select a folder.	<ul style="list-style-type: none"> • Selected • Not selected (Default: Not selected)
Look in Subfolders	Select this item to select subfolders in the selected folder when "Add all the EDS from the Directory" has been selected.	<ul style="list-style-type: none"> • Selected • Not selected (Default: Not selected)
Directory or File Name	Displays the path of the selected EDS file or selected folder. The storage location of the EDS file or folder can be directly specified.	—
[Browse] button	Displays the EDS file or the folder where EDS files have been stored.	—

4. The "EDS Management" window displays the additional result of the EDS files added to "Device Library". Check that the files have been properly added and click the [Next] button. (When the files have been properly added, OK is displayed in the "Status" field.)
 Selecting an added EDS file and clicking the [View Selected File] button displays information of the EDS file in a text file.

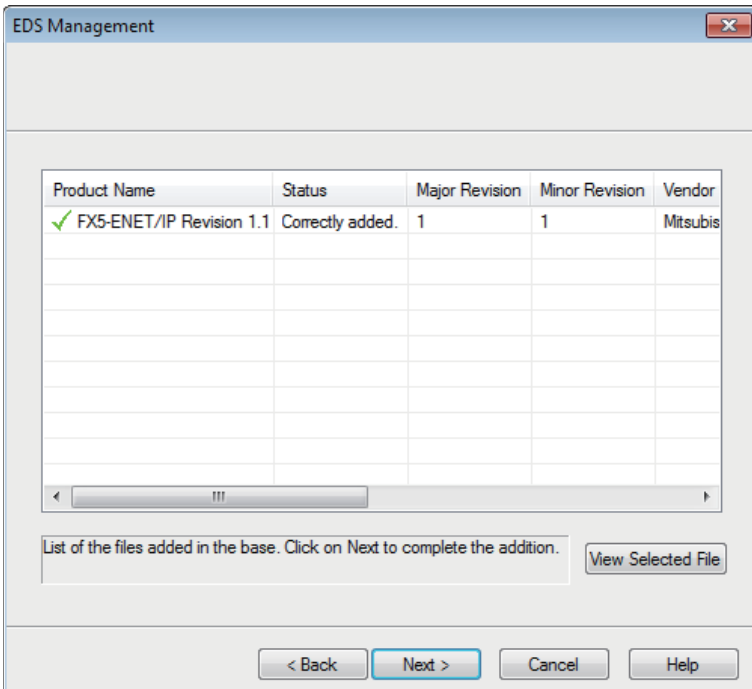

5. Click the [Finish] button to exit the EDS Management wizard.

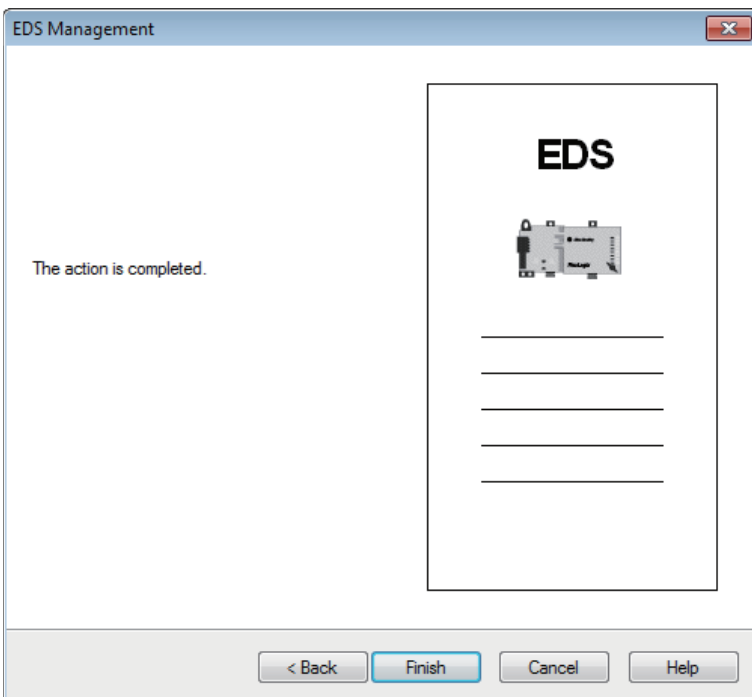

Configuring settings online

When setting EtherNet/IP devices online, the following conditions must be met.

- The FX5-ENET/IP and EtherNet/IP device are connected to the network.
- A name has been set to the EtherNet/IP device, and the name does not duplicate the name of other EtherNet/IP devices.
- An IP address has been set to the EtherNet/IP device, and the IP address does not duplicate the IP addresses of other EtherNet/IP devices.

Setting procedure

1. Add the EtherNet/IP devices to be used to "Device Library". (☞ Page 100 Adding the EDS file)

2. Detect the EtherNet/IP devices on the network. (☞ Page 69 Network Detection)

☞ Select the [Network Detection] tab ⇒ [Network] ⇒ [Read Network Configuration]

3. Add the detected EtherNet/IP devices to the network configuration settings.

[When EtherNet/IP devices are added one by one]

☞ Select the EtherNet/IP device in "Network Detection" ⇒ [Network] ⇒ [Insert in Configuration]

[When EtherNet/IP devices are added as a batch]

☞ Select the [Network Detection] tab ⇒ [Network] ⇒ [Insert and Replace All]

Configuring settings offline

When settings are configured offline, the EtherNet/IP communication settings can be configured without the FX5-ENET/IP and EtherNet/IP devices.

However, check the names of the EtherNet/IP devices used and the network configuration in advance.

Setting procedure

1. Add the EtherNet/IP devices to be used to "Device Library". (☞ Page 100 Adding the EDS file)

2. Add the EtherNet/IP devices to the network configuration settings.

☞ Select the EtherNet/IP device in "Device Library". ⇒ [Library] ⇒ [Insert in Configuration]

8.3 Checking the Software Version

Check the software version of EtherNet/IP Configuration Tool for FX5-ENET/IP in the following window.

 [Help] ⇒ [About]

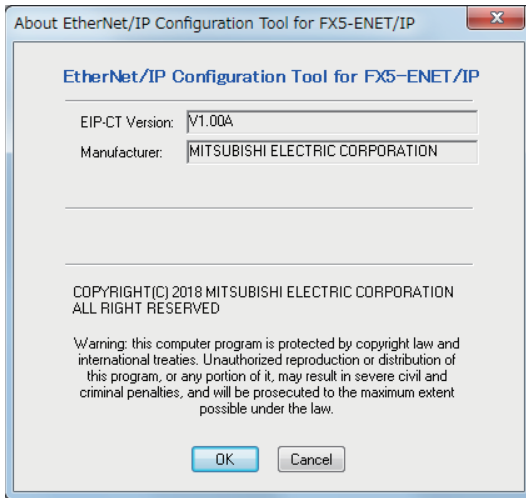

9 PROGRAMMING

This chapter describes program examples of Class 1 instance communications and UCMM message communications. For program examples of general-purpose Ethernet communication, refer to MELSEC iQ-F FX5 User's Manual (Ethernet Communication).

9.1 Program Example of Class 1 Instance Communications

This section describes examples of Class 1 instance communications.

Program example

By turning on the request command while Class1 communications are being executed, the connection information is read and written.

Program of the FX5-ENET/IP (reads the connection information)

Devices used in the program

Device	Description
M901	Execution command
M902	Execution status
M903	Normal completion
M904	Error completion
D901	Error code
D902	Error code of connection communication error
D903	Input data storage device (head number of the device)

Program example

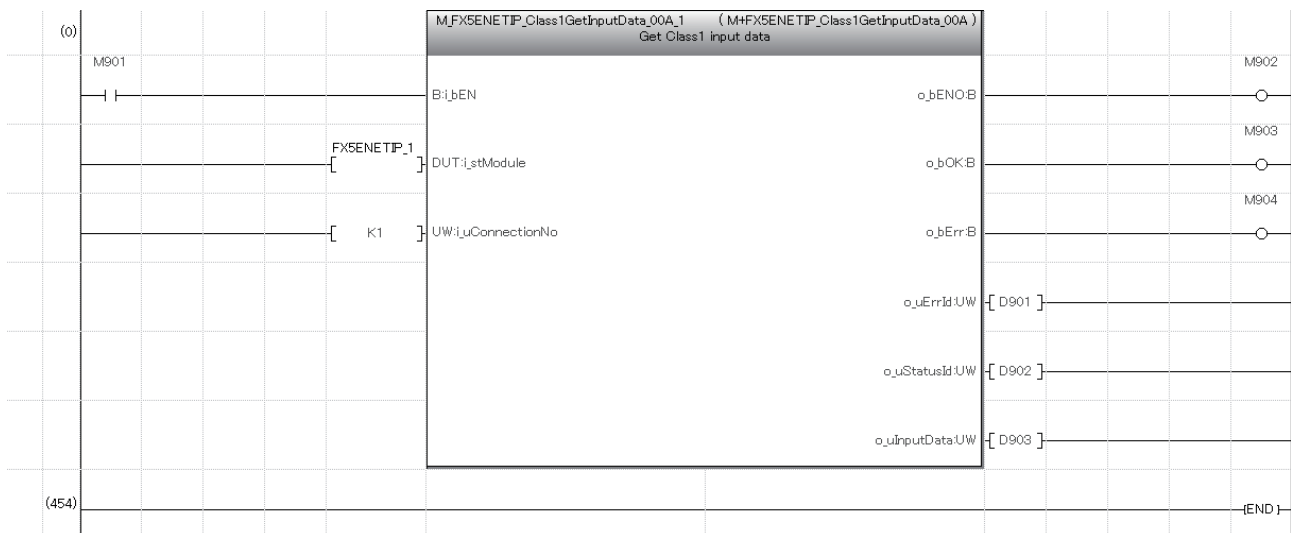

Program of the FX5-ENET/IP (writes the connection information)

■Devices used in the program

Device	Description
M1001	Execution command
M1002	Execution status
M1003	Normal completion
D1001	Error code
D1002	Error code of connection communication error
D1003	Output data storage device (head number of the device)

■Program example

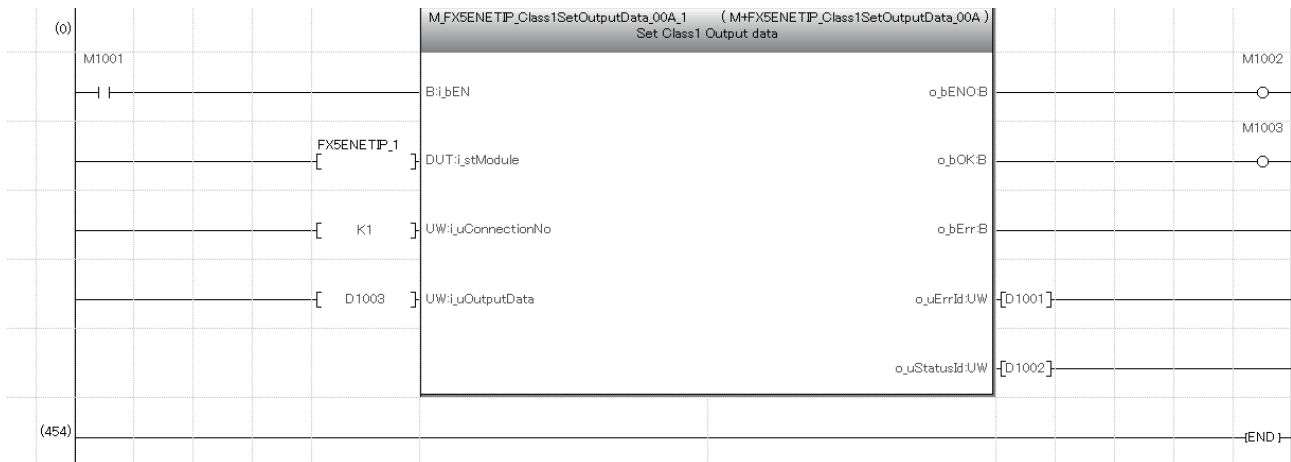

Program example

(0)	FXSENETP_1bSts_ModuleReady_D U1#G840	bCommunicationStopRequest M10				FXSENETP_1bSet_CommunicationStart upRequest_D U1#G870
(6)	bUCMMCommandSendRequest M100		MOV	H2000		FXSENETP_1unArea_Class3UCMMOutputDataArea_D[0] U1#G84000
			MOV	H302		FXSENETP_1unArea_Class3UCMMOutputDataArea_D[1] U1#G84001
			MOV	H0C0A8		FXSENETP_1unArea_Class3UCMMOutputDataArea_D[2] U1#G84002
			MOV	H1		FXSENETP_1unArea_Class3UCMMOutputDataArea_D[3] U1#G84003
			MOV	H1		FXSENETP_1unArea_Class3UCMMOutputDataArea_D[6] U1#G84006
			MOV	H1		FXSENETP_1unArea_Class3UCMMOutputDataArea_D[7] U1#G84007
			MOV	H0		FXSENETP_1unArea_Class3UCMMOutputDataArea_D[8] U1#G84008
			MOV	H0		FXSENETP_1unArea_Class3UCMMOutputDataArea_D[9] U1#G84009
			FMOV	H0	FXSENETP_1unArea_Class3UCMMOutputDataArea_D[32] U1#G84032	K707
						SET FXSENETP_1bSet_Class3UCMMApplicationTrizeerRequest_Connection_D[1] U1#G82740
						RST bUCMMCommandSendRequest M100
(80)	FXSENETP_1bnSts_Class3UCMMApplicationTrizeerAcceptance_Connection_D[1] U1#G82780	FXSENETP_1bnSts_Class3UCMMApplicationTrizeerCompletion_Connection_D[1] U1#G82820	FMOV	FXSENETP_1unArea_Class3UCMMInputDataArea_D[32] U1#G86032	unGetUCMMResponseData[0] D1000	K707
						RST FXSENETP_1bSet_Class3UCMMApplicationTrizeerRequest_Connection_D[1] U1#G82740
(98)						(END)

(0) Communication start processing

(8) Send processing of command setting and command request of UCMM message communications

(80) Acquire processing of command response of UCMM message communications

10 TROUBLESHOOTING

This section contains an explanation of errors that may occur during communication between FX5-ENET/IP and other devices, and troubleshooting for such errors.

10.1 Checking with LEDs

This section describes troubleshooting using the LEDs.

The error status can be determined by the status of the RUN LED, ERROR LED, and MS LED.

RUN LED	ERROR LED	MS LED	Error status* ¹	Description
Off	On, flashing	On in red	Major error	An error such as hardware failure or memory failure. The module stops operating.
On	Flashing	On in red	Moderate error	An error caused by an abnormal parameter affecting the module operation. The module stops operating.
On	On	Flashing in red	Minor error	An error caused by improper or inconsistent configuration. The module continues operating.

*1 When multiple errors occur, the error status is displayed in the order of major, moderate, and minor.

When the RUN LED turns off

When the RUN LED turns off after the FX5-ENET/IP is powered on, check the following.

Check item	Action
Is the FX5-ENET/IP mounted correctly?	Securely mount the FX5-ENET/IP on the CPU module.

If the above actions do not solve the problem, perform the hardware test to check for FX5-ENET/IP failure. (☞ Page 121 Hardware Test)

When the ERROR LED turns on or is flashing

When the ERROR LED turns on or is flashing, check the following.

Check item	Action
Does any error occur in the module diagnostics?	Take the actions displayed in the module diagnostics. (☞ Page 111 Module diagnostics)

When the MS LED is flashing in green

When the MS LED is flashing in green, check the following.

Check item	Action
Have the parameters been set by EtherNet/IP Configuration Tool for FX5-ENET/IP?	Set the parameters with EtherNet/IP Configuration Tool for FX5-ENET/IP if they have not been set..
Have the parameters been written normally by EtherNet/IP Configuration Tool for FX5-ENET/IP?	<ul style="list-style-type: none">• After writing the parameters, check the message displayed in the "Message window area".• Re-write the parameters.

When the MS LED turns on in red or is flashing in red

When the MS LED turns on in red or is flashing in red, check the following.

Check item	Action
Does any error occur in the module diagnostics?	Take the actions displayed in the module diagnostics. (☞ Page 111 Module diagnostics)

When the NS LED is flashing in green

When the NS LED is flashing in green, check the following.

Check item	Action
Have the following buffer memory values been checked? <ul style="list-style-type: none">• Class1 communication status 'Data link status' (Un\G6030 to Un\G6031)• Connection behavior error status 'Class1 connection 1 to 32 error code' (Un\G6262 to Un\G6293)	<ul style="list-style-type: none">• Check whether the buffer memory values are normal.• Take the action corresponding to the value of 'Class1 connection 1 to 32 error code' (Un\G6262 to Un\G6325). (☞ Page 162 Connection behavior error status (Un\G6262 to Un\G6293))
Has communication start processing been performed correctly with 'EtherNet/IP communication start request' (Un\G37.b0)?	<ul style="list-style-type: none">• Check that 'EtherNet/IP communication start request' (Un\G37.b0) is on.• If 'EtherNet/IP data link continuation specification' (Un\G5004) is set to "16: continue EtherNet/IP communication", turn 'EtherNet/IP communication start request' (Un\G37.b0) on again.

When the NS LED is flashing in red

When the NS LED is flashing in red, check the following.

Check item	Action
Is the EtherNet/IP device connected correctly?	<ul style="list-style-type: none">• Check whether the operating status of the EtherNet/IP device is normal. (☞ Page 123 EtherNet/IP communications cannot be performed)• Check for errors in the line status.• The line may be busy, so retry at a later time.

When the SD/RD LED does not turn on during data communication

When the SD/RD LED does not turn on during data communication, check the following.

Check item	Action
Is the ERROR LED on or flashing?	Take the actions displayed in the module diagnostics. (☞ Page 111 Module diagnostics)
Is the Ethernet cable connected correctly?	<ul style="list-style-type: none">• Connect the Ethernet cable again.• Perform a PING test to check the line status. (☞ Page 120 PING test)
Are the parameter settings correct?	Revise the following items with EtherNet/IP Configuration Tool for FX5-ENET/IP. <ul style="list-style-type: none">• Model and name of the connected EtherNet/IP device• IP address of the connected EtherNet/IP device• Version of the registered EDS file
Are there any errors in the program?	<ul style="list-style-type: none">• Check that 'EtherNet/IP communication start request' (Un\G37.b0) is on.• Check and correct the data communication program.

If the above actions do not solve the problem, perform the hardware test to check for FX5-ENET/IP failure. (☞ Page 121 Hardware Test)

10.2 Checking the Module Status

The status of FX5-ENET/IP module can be checked by the following methods.

- Module diagnostics
- Ethernet diagnostics
- Checking the buffer memory
- Event history function

Module diagnostics

The following functions can be used in the "Module Diagnostics" window for the FX5-ENET/IP.

Function	Application
Error Information	Displays the details of the errors currently occurring. Click the [Event History] button to check the history of errors that have occurred on the FX5-ENET/IP, errors detected for each module.
Module Information List	Displays various status information of the FX5-ENET/IP.

Error Information

Check the details of the error currently occurring and action to eliminate the error.

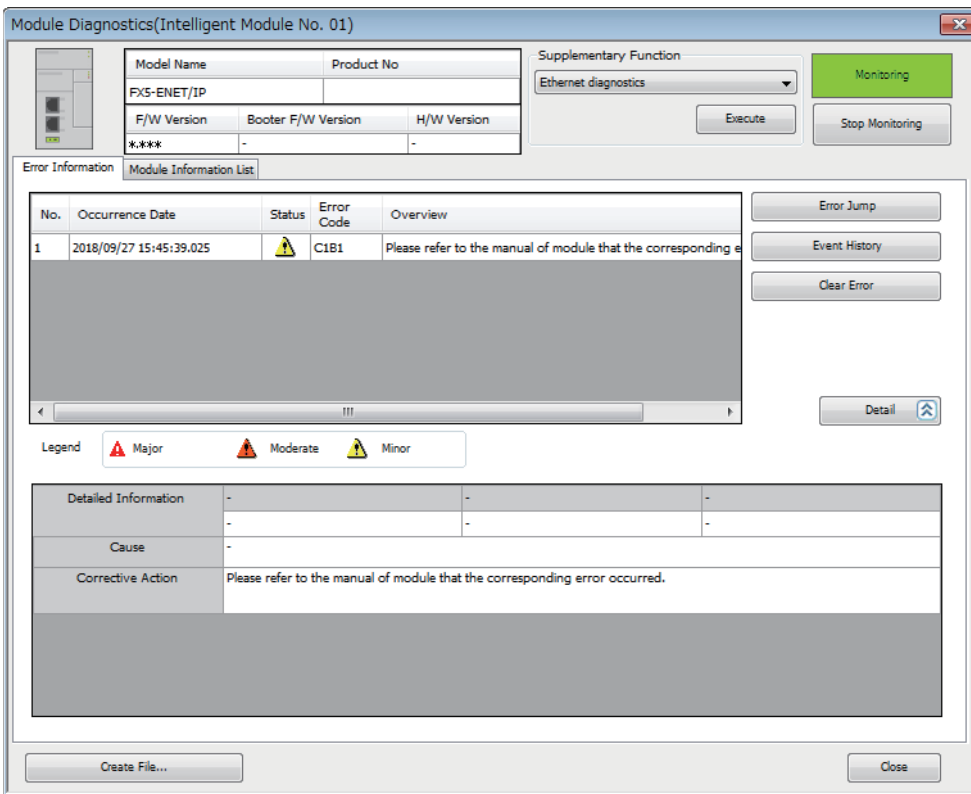

Item	Description
Status	Major: An error such as hardware failure or memory failure. The module stops operating.
	Moderate: An error, such as parameter error, which affects module operation. The module stops operating.
	Minor: An error such as communication failure. The module continues operating.
Detailed Information	Displays detailed information about each error (maximum of three pieces).
Cause	Displays the detailed error causes.
Corrective Action	Action Displays the actions to eliminate the error causes.

Module Information List

Switch to the [Module Information List] tab to check various status information of the FX5-ENET/IP.

Item	Content
LED information (Module)	
RUN	
ERR.	
LED information (Network)	
MS	Blink(Red):Mild error occurrence
NS	Off:Power outage or IP address not set
Individual information	
Module Operation Mode	Online mode
IP address(1st octet)	10
IP address(2nd octet)	166
IP address(3rd octet)	251
IP address(4th octet)	1
Mac address(1st octet)	**
Mac address(2nd octet)	**
Mac address(3rd octet)	**
Mac address(4th octet)	**
Mac address(5th octet)	**
Mac address(6th octet)	**

Item	Description	
LED information (Module)	Displays the status of the RUN LED and ERROR LED of the FX5-ENET/IP.	
LED information (Communication)*1	Displays the status of the MS LED and NS LED of the FX5-ENET/IP.	
Setting information*1	IP Address (1st Octet)	Displays the IP address of the FX5-ENET/IP.
	IP Address (2nd Octet)	
	IP Address (3rd Octet)	
	IP Address (4th Octet)	
	MAC Address (1st Octet)	Displays the MAC address of the FX5-ENET/IP.
	MAC Address (2nd Octet)	
	MAC Address (3rd Octet)	
	MAC Address (4th Octet)	
	MAC Address (5th Octet)	
MAC Address (6th Octet)		

*1 An undefined value is stored during hardware test.

Ethernet diagnostics

To check the status of general-purpose Ethernet, parameter setting and communication status, perform the "Ethernet Diagnostics" of GX Works3.

 [Diagnostics] ⇒ [Ethernet Diagnostics] ⇒ Select the "Module" in the [Target Module Specification].

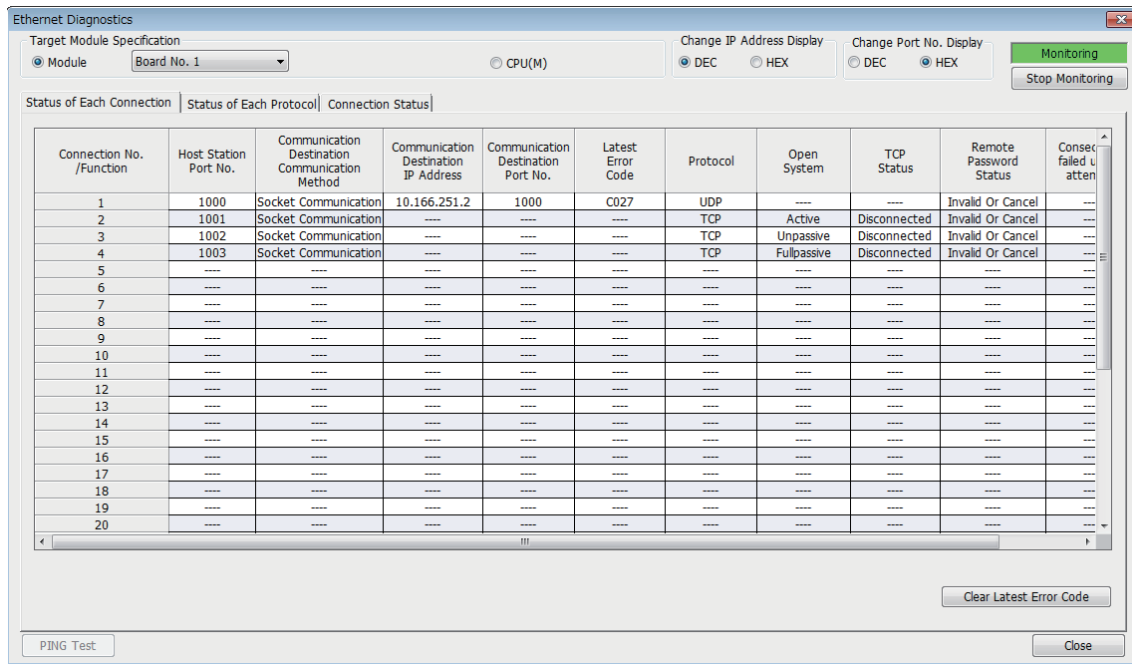

The following functions can be used in the "Ethernet Diagnostics" window for the FX5-ENET/IP.

Function	Application
Status of Each Connection	Displays information concerning status of each connection.
Status of Each Protocol	The total of the send/receive of the packet etc. for each protocol is displayed.
Connection Status	Monitors connection status.

Status of Each Connection

The status of each connection of the FX5-ENET/IP selected.

 [Diagnostics] ⇒ [Ethernet Diagnostics] ⇒ Select the "Module" in the [Target Module Specification]. ⇒ Select the [Status of Each Connection] tab.

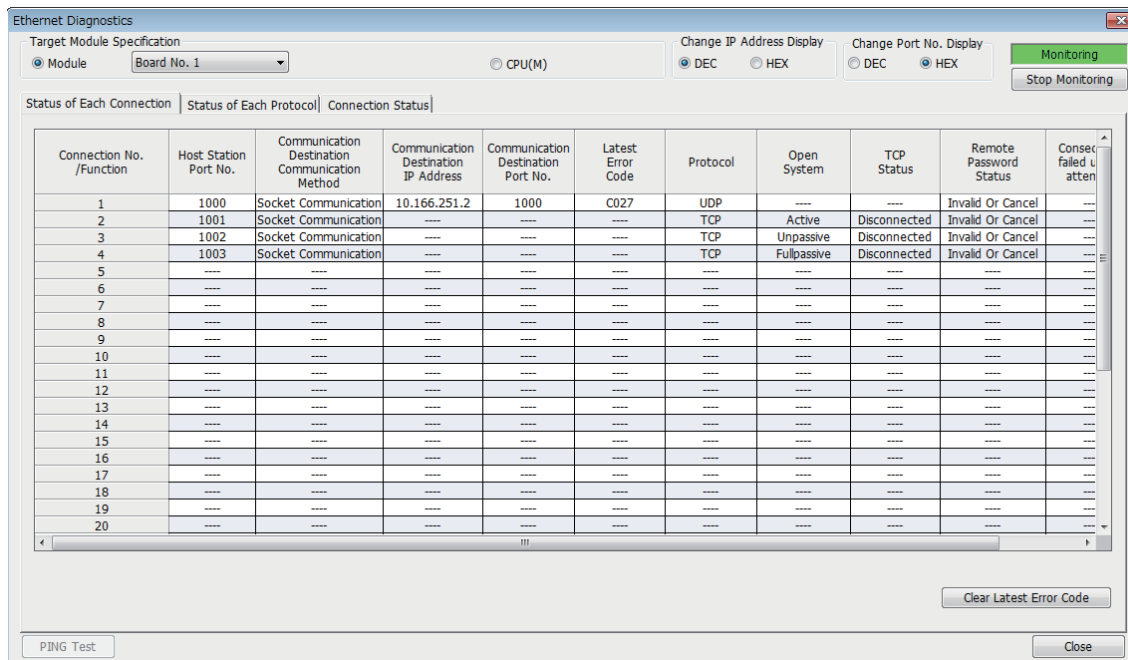

Item	Description
Connection No./Function	Displays the connection number and functions.
Host Station Port No.	Displays the own station port number used.
Communication Destination Communication Method	Displays the communication method.
Communication Destination IP Address	Displays the IP address of the sensor/device to be connected, which is set in the parameter settings.
Communication Destination Port No.	Displays the port number of the sensor/device to be connected, which is set in the parameter settings.
Latest Error Code	Displays the error code that indicates the definition of latest error occurred.
Protocol	Displays the protocol (TCP/IP or UDP/IP).
Open System	Displays the open method (Active, Unpassive, or Fullpassive) when the protocol of the connection is TCP/IP.
TCP Status	Displays the status (open status) of connection with the sensor/device when the protocol of the connection status is TCP/IP.
Remote Password Status	Not supported.
Continuous Unlock Lost Counts	Not supported.

Click the [Clear Latest Error Code] button to clear all the errors displayed in "Latest Error Code" of each connection.

Status of Each Protocol

The total number of packets sent/received by each protocol of the selected FX5-ENET/IP can be checked.

 [Diagnostics] ⇒ [Ethernet Diagnostics] ⇒ Select the "Module" in the [Target Module Specification]. ⇒ Select the [Status of Each Protocol] tab.

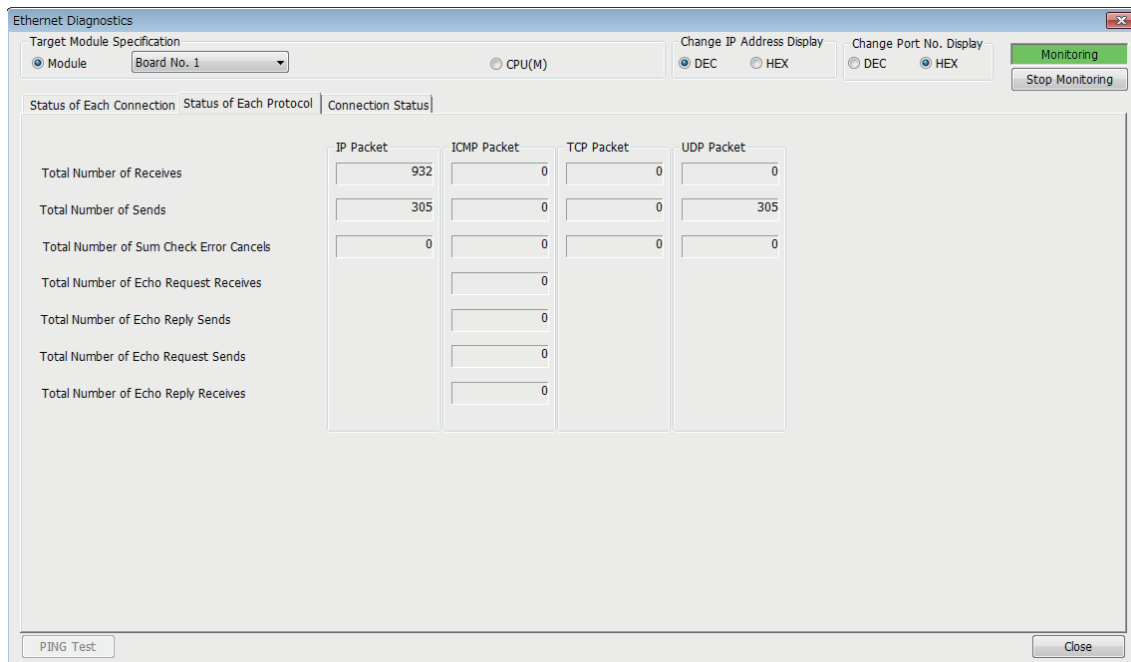

	IP Packet	ICMP Packet	TCP Packet	UDP Packet
Total Number of Receives	932	0	0	0
Total Number of Sends	305	0	0	305
Total Number of Sum Check Error Cancels	0	0	0	0
Total Number of Echo Request Receives		0		
Total Number of Echo Reply Sends		0		
Total Number of Echo Request Sends		0		
Total Number of Echo Reply Receives		0		

Item	Description	Display range
Total Number of Receives	Displays the total number of received packets.	0 to 4294967295
Total Number of Sends	Displays the total number of sent packets.	0 to 4294967295
Total Number of Sum Check Error Cancels	Not supported.	—
Total Number of Echo Request Receives	Displays the total number of received ICMP echo request packets.	0 to 4294967295
Total Number of Echo Reply Sends	Displays the total number of sent ICMP echo reply packets.	0 to 4294967295
Total Number of Echo Request Sends	Displays the total number of sent ICMP echo request packets.	0 to 4294967295
Total Number of Echo Reply Receives	Displays the total number of received ICMP echo reply packets.	0 to 4294967295

Connection Status

The communication status of the FX5-ENET/IP.

[Diagnostics] ⇒ [Ethernet Diagnostics] ⇒ Select the "Module" in the [Target Module Specification]. ⇒ Select the [Connection Status] tab.

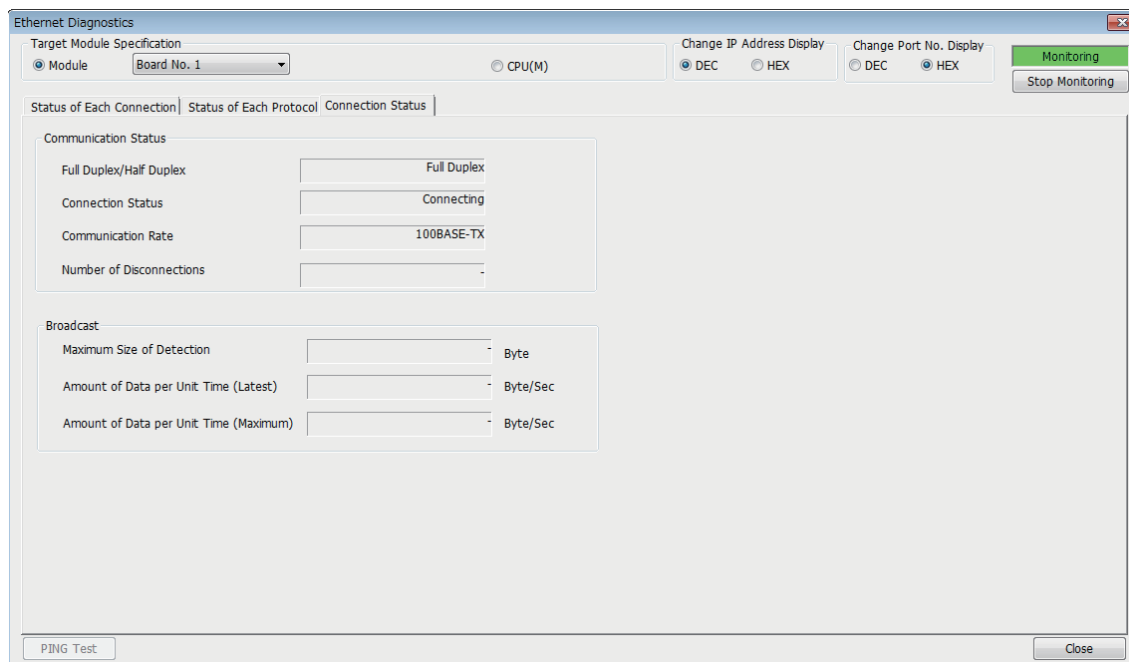

Item	Description	Display range	
Communication Status	Full Duplex/Half Duplex	Displays the communication mode of the line.	—
	Connection Status	Displays the cable connection status.	—
	Communication Rate	Displays the communication speed.	—
	Number of Disconnections	Not supported.	—
Broadcast	Maximum Size of Detection	Not supported.	—
	Amount of Data per Unit Time (Latest)	Not supported.	—
	Amount of Data per Unit Time (Maximum)	Not supported.	—

Checking the buffer memory

The buffer memories can be used to check for errors that have occurred in FX5-ENET/IP.

EtherNet/IP communication error

If an error occurs during EtherNet/IP communication, check the following buffer memories.

Buffer memory address	Buffer memory name	Description
Un\G6034 to Un\G6035	Class1 communications status abnormal condition	The bit corresponding to the connection where the EtherNet/IP communication error has occurred will be turned on.
Un\G6262 to Un\G6293	Connection behavior error status Class1 connection 1 to 32 error code	The error code will be saved in the buffer memory corresponding to the connection where the EtherNet/IP communication error has occurred.

For the stored error code, refer to  Page 124 EtherNet/IP communication error.

Module error

If an error occurs in FX5-ENET/IP, check the following buffer memories.

Buffer memory address	Buffer memory name	Description
Un\G29	Latest error code	Stores the latest error code.
Un\G158	Initial status	It is possible to confirm whether the initialization is normally completed.
Un\G159	Initial abnormal code	An error code will be stored when the initialization is abnormally completed.

For the stored error code, refer to  Page 128 Module error.

Ethernet communication error

If an error occurs during general-purpose Ethernet communication, the error code will be stored in the following buffer memory.

Buffer memory address	Buffer memory name	Description
Un\G108 to Un\G139	Error code	Error code of each connection (1 to 32) is stored.

For the stored error code, refer to  Page 132 Ethernet communication error.

Event history function

This function collects errors from FX5-ENET/IP, and keeps them in the SD memory card, and data memory or battery backed built-in RAM of the CPU module.

The event information collected by the CPU module can be displayed on GX Works3 to check the occurrence history in chronological order.

Event type	Classification	Description
System	Error	An error detected by the self diagnostics in FX5-ENET/IP.

For event code, refer to  Page 135 List of Event Code.

Setting procedure

The event history function can be set from the event history setting window of GX Works3. For the setting procedure, refer to the following.

 MELSEC iQ-F FX5 User's Manual (Application)

Displaying event history

Access the menu of GX Works3. For details on the operating procedure and how to view the contents, refer to the following.

 GX Works3 Operating Manual

10.3 Checking the Network Status

Use the following methods to check the EtherNet/IP network status.

- Network diagnostics of EtherNet/IP Configuration Tool for FX5-ENET/IP
- Checking with the buffer memory
- PING test

Network diagnostics of EtherNet/IP Configuration Tool for FX5-ENET/IP

The network diagnostics of EtherNet/IP Configuration Tool for FX5-ENET/IP can be used to check the connection information of EtherNet/IP devices.

For details on EtherNet/IP Configuration Tool for FX5-ENET/IP, refer to the following.

☞ Page 57 EtherNet/IP Configuration Tool for FX5-ENET/IP

Displaying the connection status of EtherNet/IP device

Enabling diagnostic mode in EtherNet/IP Configuration Tool for FX5-ENET/IP displays the connection status of the EtherNet/IP device.

Operating procedure

1. Connect a personal computer on which EtherNet/IP Configuration Tool for FX5-ENET/IP is installed to the same network as the FX5-ENET/IP.
2. Start EtherNet/IP Configuration Tool for FX5-ENET/IP.
3. Add the EtherNet/IP device to the network configuration settings. (☞ Page 100 Procedure for Registering EtherNet/IP Devices)
4. Switch EtherNet/IP Configuration Tool for FX5-ENET/IP to the online state.

☞ [File] ⇒ [Go Online]

5. Write the set parameters to the FX5-ENET/IP.

☞ [File] ⇒ [Download]

6. Enable diagnostic mode.

☞ [Device] ⇒ [Diagnostic]

7. When the diagnostic mode is enabled, the connection status of EtherNet/IP devices is displayed in the network configuration setting.

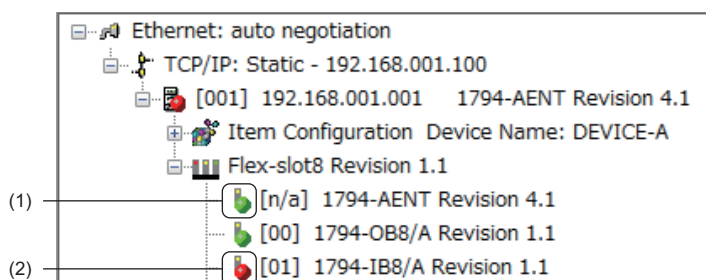

(1) An EtherNet/IP device is connected, and EtherNet/IP communications are in progress.

(2) An EtherNet/IP device is connected, but EtherNet/IP communications are not in progress.

To check the connection status of EtherNet/IP devices, the actual network configuration needs to be written to the FX5-ENET/IP with EtherNet/IP Configuration Tool for FX5-ENET/IP. When the diagnostic mode is enabled, the network configuration setting cannot be changed.

Point

To start EtherNet/IP communications and network diagnostics of EtherNet/IP Configuration Tool for FX5-ENET/IP, 'EtherNet/IP communication start request' (Un\G37.b0) must be turned off and on and 'EtherNet/IP communication in process' (Un\G35.b0) must be in the ON state.

Checking the connection information of EtherNet/IP devices

This section describes how to check the connection information of EtherNet/IP devices.

Setting data

1. Display the EtherNet/IP device setting window.
☞ Select the EtherNet/IP display in the network configuration settings. ⇒ [Device] ⇒ [Properties]
2. Select the [Diagnostic] tab.
3. Select an EtherNet/IP device to display its connection information. For details on the window, refer to the following.
☞ Page 94 [Diagnostic] tab

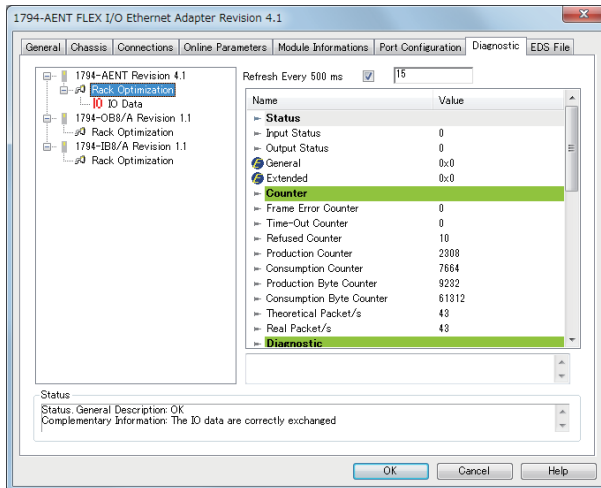

Checking the I/O data of EtherNet/IP devices

This section describes how to check the I/O data of EtherNet/IP devices.

Operating procedure

1. Display the EtherNet/IP device setting window.
☞ Select the EtherNet/IP display in the network configuration settings. ⇒ [Device] ⇒ [Properties]
2. Select the [Diagnostic] tab.
3. I/O data information is displayed when "IO Data" is selected. For details on the window, refer to the following.
☞ Page 94 [Diagnostic] tab

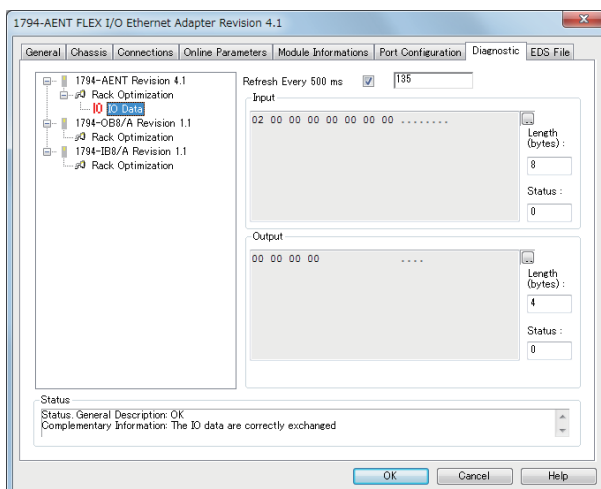

Checking with the buffer memory

The status of the Class1 communication connections and the error details can be checked with the following buffer memory areas.

- Class1 communication status 'Data link status' (Un\G6030 to Un\G6031)
- Class1 communication status 'Error status' (Un\G6034 to Un\G6035)
- Connection behavior error status 'Class1 connection 1 to 32 error code' (Un\G6262 to Un\G6293)

Status of each connection

The connection status can be checked by checking the bit corresponding to each connection in 'Data link status' (Un\G6030 to Un\G6031), and 'Error status' (Un\G6034 to Un\G6035).

'Data link status' (Un\G6030 to Un\G6031)	'Error status' (Un\G6034 to Un\G6035)	Status of each connection
Off	Off	Not connected or data link not in operation.
On	Off	Data link in operation. No error has occurred.
Off	On	Error has occurred with data link not in operation.
On	On	Error has occurred with data link in operation.

No error is generated for combinations other than those listed above. For details on the Class1 communication status, refer to the following.

☞ Page 162 Class1 communication status

Error details of each connection

The error code of each connection can be checked with 'Class1 connection 1 to 32 error code' (Un\G6262 to Un\G6293).

For details on the buffer memory, refer to the following.

☞ Page 162 Connection behavior error status

For error code descriptions, refer to the following.

☞ Page 124 List of Error Codes

PING test

A PING test is used to check that an EtherNet/IP device exists on the same EtherNet/IP network.

The FX5-ENET/IP sends a packet to the EtherNet/IP device to check its existence (an echo request). Then, the FX5-ENET/IP checks whether communication is possible by seeing whether a response (an echo response) is returned.

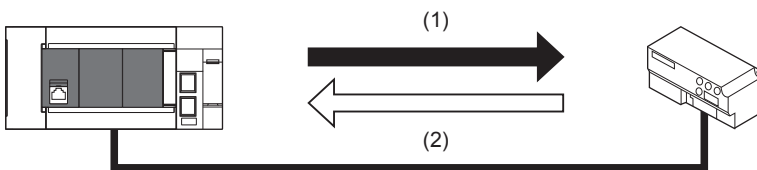

- (1) Echo request
(2) Echo response

Check method

The following methods are available for checking the PING test.

■Checking from EtherNet/IP Configuration Tool for FX5-ENET/IP

Use EtherNet/IP Configuration Tool for FX5-ENET/IP to execute a PING test.

For details, refer to the following.

☞ Page 74 [Ping] tab

☞ Page 84 [General] tab

10.4 Hardware Test

This section describes how to perform a test related to hardware, such as a ROM/RAM of the FX5-ENET/IP.

Restriction

- During the hardware test, values in the buffer memory cannot be referred from the GX Works3 or the program.
- Do not change the operating status of the CPU module during the hardware test. If the operating status of the CPU module is changed, the module major error occurs in the CPU module.

Operating procedure

1. Set the FX5-ENET/IP to the hardware test mode using the GX Works3.

[Navigation window] ⇒ [Parameter] ⇒ [Module Information] ⇒ [FX5-ENET/IP] ⇒ [Indispensable Setting] ⇒ [Mode Settings] ⇒ Select "Hardware Test"

2. When a cable is connected to the Ethernet port of FX5-ENET/IP, disconnect it.

3. Set the CPU module (FX5-ENET/IP) to the STOP state and write parameters.

4. Power off and on the system or reset the CPU module (FX5-ENET/IP).

5. The hardware test is automatically executed.

The following table shows the LED indications of the FX5-ENET/IP for the hardware test.

Status	RUN LED	ERROR LED
During hardware test execution	Flashing	Off
Hardware test completed successfully	On	Off
Hardware test completed with an error	On	On

6. When the test completed successfully, set the FX5-ENET/IP to online mode using the GX Works3.

[Navigation window] ⇒ [Parameter] ⇒ [Module Information] ⇒ [FX5-ENET/IP] ⇒ [Indispensable Setting] ⇒ [Mode Settings] ⇒ Select "Online"

Write parameters and power off and on the system or reset the CPU module (FX5-ENET/IP).

7. When the test completed with an error, check that adequate measures to reduce noise are taken for the programmable controller system and retry the hardware test. If the test still completes with an error, a hardware failure may have occurred on the FX5-ENET/IP. Please consult your local Mitsubishi representative.

10.5 Troubleshooting by Symptom

The troubleshooting measures for each symptom during EtherNet/IP communication are shown below. If an error has occurred in the FX5-ENET/IP, identify the error cause using the GX Works3. (☞ Page 111 Checking the Module Status)

Communications with EtherNet/IP devices cannot be performed

The following table lists the actions to be taken if communications with EtherNet/IP devices cannot be performed.

Check item	Action
Is the RUN LED of the FX5-ENET/IP off?	If the RUN LED is off, reset the CPU module. If resetting does not cause the RUN LED to turn on, a hardware failure may have occurred. Replace the FX5-ENET/IP and restart the connected EtherNet/IP device.
Is the Ethernet cable connected correctly?	<ul style="list-style-type: none"> • Connect the Ethernet cable again. • Perform a PING test to check the connection with the EtherNet/IP device.
Is the EtherNet/IP device compatible with the FX5-ENET/IP communication functions (Class1 communications, Class3 communications, and UCMM communications)?	Check the specifications of the EtherNet/IP device.
Is the power supply of the EtherNet/IP device on?	Turn on the power supply of the EtherNet/IP device.
Has an error occurred on the EtherNet/IP device, switching hub, or a similar device?	If an error has occurred on the EtherNet/IP device, switching hub, or a similar device, check the manual of each device.
Is the IP address setting of the EtherNet/IP device correct?	Perform a PING test to check the connection with the EtherNet/IP device. (☞ Page 120 PING test)
Is the mode setting of the FX5-ENET/IP a value other than "Online"?	Set the mode setting of the FX5-ENET/IP to "Online" using the GX Works3.
Has the initial processing completed successfully?	Check whether communication is starting after 'Module ready' (Un\G34.b0) turns on.
Has communication start processing been performed correctly with 'EtherNet/IP communication start request' (Un\G37.b0)?	<ul style="list-style-type: none"> • Check that 'EtherNet/IP communication start request' (Un\G37.b0) is on. • If 'EtherNet/IP data link continuation specification' (Un\G5004) is set to "16: continue EtherNet/IP communication", turn 'EtherNet/IP communication start request' (Un\G37.b0) on again.
Is the EtherNet/IP device connected ahead of the router?	Communication through the router cannot be established. Reexamine the connection of the EtherNet/IP device.
Has a timeout error occurred on the connection that performs communications normally?	Depending on the EtherNet/IP device used, the connection that performs communications normally may be disconnected and a timeout error may occur after the time specified by Encapsulation Inactivity Timeout has elapsed. Therefore, set Encapsulation Inactivity Timeout to 0 (invalid). (☞ Page 171 TCP/IP Interface)

If the above actions do not solve the problem, perform the hardware test to check for hardware failure. (☞ Page 121 Hardware Test)

FX5-ENET/IP cannot connect to EtherNet/IP Configuration Tool for FX5-ENET/IP

The following table lists the actions to be taken if the FX5-ENET/IP cannot connect to EtherNet/IP Configuration Tool for FX5-ENET/IP (personal computer).

Check item	Action
Are the IP address settings for the FX5-ENET/IP and the personal computer to connect correct?	Set the IP addresses so that they have the same class and subnet address.
Is the RUN LED of the FX5-ENET/IP off?	If the RUN LED is off, reset the CPU module. If resetting does not cause the RUN LED to turn on, a hardware failure may have occurred. Replace the FX5-ENET/IP and restart the connected EtherNet/IP device.
Can network diagnostics be performed? (☞ Page 118 Checking the Network Status)	Check that 'EtherNet/IP communication start request' (Un\G37.b0) is on.

If the above actions do not solve the problem, perform the hardware test to check for hardware failure. (☞ Page 121 Hardware Test)

EtherNet/IP communications cannot be performed

The following table lists the actions to be taken if EtherNet/IP communications (Class1 instance communications, Class3 message communications, UCMM message communications) cannot be performed.

■Class1 instance communications

Check item	Action
Has the EtherNet/IP device to connect been registered in EtherNet/IP Configuration Tool for FX5-ENET/IP?	If the EtherNet/IP device to connect is not displayed in the network configuration setting of EtherNet/IP Configuration Tool for FX5-ENET/IP, add the device. (☞ Page 100 Procedure for Registering EtherNet/IP Devices)
Has communication start processing been performed correctly with 'EtherNet/IP communication start request' (Un\G37.b0)?	<ul style="list-style-type: none"> • 'Check that 'EtherNet/IP communication start request' (Un\G37.b0) is on. • 'If 'EtherNet/IP data link continuation specification' (Un\G5004) is set to "16: continue EtherNet/IP communication", turn 'EtherNet/IP communication start request' (Un\G37.b0) on again.
Is the instance ID specified correctly?	Referring to the manual of the EtherNet/IP device connected, check the parameters of the originator to confirm if the specified instance ID is available for receiving request. When the specified instance ID is not available for receiving request, change the instance ID and write the parameter again.
Is input data stored in 'Class1 communications input data area' (Un\G12000 to Un\G35999)?	Check that the unit FB (Class1 communication input data acquisition) is used.
Is output data set in 'Class1 communications output data area' (Un\G60000 to Un\G83999)?	Check that the unit FB (Class1 communication output data setting) is used.

■Class3 message communications

Check item	Action
Are the commands received from the EtherNet/IP device supported by the FX5-ENET/IP?	Check that the commands supported by the FX5-ENET/IP are transmitted. ☞ Page 166 Details of Message Communication Support Command
Has communication start processing been performed correctly with 'EtherNet/IP communication start request' (Un\G37.b0)?	<ul style="list-style-type: none"> • 'Check that 'EtherNet/IP communication start request' (Un\G37.b0) is on. • 'If 'EtherNet/IP data link continuation specification' (Un\G5004) is set to "16: continue EtherNet/IP communication", turn 'EtherNet/IP communication start request' (Un\G37.b0) on again.

■UCMM message communications

Check item	Action
Are the settings of the commands to request correct?	Check the value set in 'UCMM communications output data area' (Un\G84000 to Un\G107999).
Has communication start processing been performed correctly with 'EtherNet/IP communication start request' (Un\G37.b0)?	<ul style="list-style-type: none"> • 'Check that 'EtherNet/IP communication start request' (Un\G37.b0) is on. • 'If 'EtherNet/IP data link continuation specification' (Un\G5004) is set to "16: continue EtherNet/IP communication", turn 'EtherNet/IP communication start request' (Un\G37.b0) on again.

10.6 List of Error Codes

This section lists the error codes, error details and causes, and actions for the errors that occur in the processing for data communications between the FX5-ENET/IP and external devices or that are caused by processing requests from the CPU module on the own station.

The FX5-ENET/IP has the following error codes.

Type	Error code	Reference
EtherNet/IP communication error	102H to 2FFH	Page 124
Module error	0800H to 4043H	Page 128
Ethernet communication error	C012H to CFBFH	Page 132

EtherNet/IP communication error

The EtherNet/IP communication error codes are stored in 'Class1 connection 1 to 32 error code' (Un\G6262 to Un\G6293). The Class1 communication status 'Error status' (Un\G6034 to Un\6035) bit corresponding to the connection where the error has occurred is turned on.

Error code	Error name	Error details and causes	Action
102H	Access not possible	An error was detected in the memory.	<ul style="list-style-type: none"> Take measures to reduce noise. Reset the CPU module, and then switch it to RUN mode. If the error occurs again even after the above action is taken, the possible cause is a hardware failure of the module. Please consult your local Mitsubishi representative.
103H	Parameter error	A parameter error was detected.	<ul style="list-style-type: none"> Use EtherNet/IP Configuration Tool for FX5-ENET/IP to write the parameters to the module again. When performing UCMM communications, check whether the setting details of the UCMM request area are correct.
104H to 105H	Connection timeout	A timeout occurred in the connection with the external device.	<ul style="list-style-type: none"> Check whether the operating status of the external device is normal. Check for errors in the line status. The line may be busy, so retry at a later time. The external device may not be able to send data at the specified RPI due to a high communication load, so specify a larger RPI and connect again.
106H	Target device invalid	The target device does not exist.	<ul style="list-style-type: none"> Use EtherNet/IP Configuration Tool for FX5-ENET/IP to write the parameters to the module again. If the error occurs again even after the above action is taken, the possible cause is a hardware failure of the module on which the error occurred. Please consult your local Mitsubishi representative.
107H	Memory error	An error was detected in the memory.	<ul style="list-style-type: none"> Take measures to reduce noise. Reset the CPU module, and then switch it to RUN mode. If the error occurs again even after the above action is taken, the possible cause is a hardware failure of the module on which the error occurred. Please consult your local Mitsubishi representative.
10AH	Connection start error	Production processing failed to start.	<ul style="list-style-type: none"> Take measures to reduce noise. Reset the CPU module, and then switch it to RUN mode. If the error occurs again even after the above action is taken, the possible cause is a hardware failure of the module on which the error occurred. Please consult your local Mitsubishi representative.
10BH	Connection start error	Consumption processing failed to start.	<ul style="list-style-type: none"> Take measures to reduce noise. Reset the CPU module, and then switch it to RUN mode. If the error occurs again even after the above action is taken, the possible cause is a hardware failure of the module on which the error occurred. Please consult your local Mitsubishi representative.
10CH	Insufficient memory	There is insufficient memory available for connection processing.	<ul style="list-style-type: none"> Retry at a later time. Reset the CPU module, and then switch it to RUN mode. If the error occurs again even after the above action is taken, the possible cause is a hardware failure of the module on which the error occurred. Please consult your local Mitsubishi representative.

Error code	Error name	Error details and causes	Action
10EH to 10FH	TCP error	An error has occurred in TCP communications.	<ul style="list-style-type: none"> • Retry at a later time. • Check whether the operating status of the external device is normal. • Check for errors in the line status. • The line may be busy, so retry at a later time. • Reset the CPU module, and then switch it to RUN mode. If the error occurs again even after the above action is taken, the possible cause is a hardware failure of the module on which the error occurred. Please consult your local Mitsubishi representative.
110H	TCP error	Socket generation has failed.	<ul style="list-style-type: none"> • Retry at a later time. • Reset the CPU module, and then switch it to RUN mode. If the error occurs again even after the above action is taken, the possible cause is a hardware failure of the module on which the error occurred. Please consult your local Mitsubishi representative.
112H	TCP error	Incorrect send data has been specified.	<ul style="list-style-type: none"> • Take measures to reduce noise. • Reset the CPU module, and then switch it to RUN mode. If the error occurs again even after the above action is taken, the possible cause is a hardware failure of the module on which the error occurred. Please consult your local Mitsubishi representative.
113H	TCP error	There is insufficient cache memory available.	<ul style="list-style-type: none"> • Retry at a later time. • Restart the FX5-ENET/IP.
114H	TCP error	Failed to set the socket option (non-blocking).	<ul style="list-style-type: none"> • Take measures to reduce noise. • Reset the CPU module, and then switch it to RUN mode. If the error occurs again even after the above action is taken, the possible cause is a hardware failure of the module. Please consult your local Mitsubishi representative.
115H	TCP error	The frame size has exceeded the maximum size.	<ul style="list-style-type: none"> • Use EtherNet/IP Configuration Tool for FX5-ENET/IP to write the parameters to the module again. • When performing UCMM communications, check whether the setting details of the UCMM request area are correct.
119H	CIP error	A timeout occurred in the connection with the external device.	<ul style="list-style-type: none"> • Check whether the operating status of the external device is normal. • Check for errors in the line status. • The line may be busy, so retry at a later time. • The external device may not be able to send data at the specified RPI due to a high communication load, so specify a larger RPI and connect again.
11AH	CIP error	An incorrect Forward Open service request has been received from the external device.	<ul style="list-style-type: none"> • Check whether the operating status of the external device is normal. • Check for errors in the line status. • The line may be busy, so retry at a later time. • The external device may not be able to send data at the specified RPI due to a high communication load, so specify a larger RPI and connect again.
11BH	CIP error	Incorrect network parameters (originator to target) have been received from the external device.	<ul style="list-style-type: none"> • Check whether the operating status of the external device is normal. • Check for errors in the line status. • The line may be busy, so retry at a later time. • The external device may not be able to send data at the specified RPI due to a high communication load, so specify a larger RPI and connect again.
11CH	CIP error	Incorrect network parameters (target to originator) have been received from the external device.	<ul style="list-style-type: none"> • Check whether the operating status of the external device is normal. • Check for errors in the line status. • The line may be busy, so retry at a later time. • The external device may not be able to send data at the specified RPI due to a high communication load, so specify a larger RPI and connect again.
11DH	CIP error	An incorrect UDP port specification has been received from the external device.	<ul style="list-style-type: none"> • Check whether the external device is set to use UDP port number 2222 for EtherNet/IP communications. • Check whether the operating status of the external device is normal. • Check for errors in the line status. • The line may be busy, so retry at a later time. • The external device may not be able to send data at the specified RPI due to a high communication load, so specify a larger RPI and connect again.
11EH	CIP error	Participation in a multicast group has failed.	<ul style="list-style-type: none"> • Take measures to reduce noise. • Reset the CPU module, and then switch it to RUN mode. If the error occurs again even after the above action is taken, the possible cause is a hardware failure of the module on which the error occurred. Please consult your local Mitsubishi representative.

Error code	Error name	Error details and causes	Action
11FH	Memory error	An error was detected in the memory.	<ul style="list-style-type: none"> • Take measures to reduce noise. • Reset the CPU module, and then switch it to RUN mode. If the error occurs again even after the above action is taken, the possible cause is a hardware failure of the module on which the error occurred. Please consult your local Mitsubishi representative.
120H	CIP error	The available resources are insufficient.	<ul style="list-style-type: none"> • Take measures to reduce noise. • Reset the CPU module, and then switch it to RUN mode. If the error occurs again even after the above action is taken, the possible cause is a hardware failure of the module on which the error occurred. Please consult your local Mitsubishi representative.
121H	Connection error	The connection has stopped.	<ul style="list-style-type: none"> • The line may be busy, so retry at a later time. • The external device may not be able to send data at the specified RPI due to a high communication load, so specify a larger RPI and connect again.
124H	Connection error	The connection has been set to disabled.	Check the parameter set with EtherNet/IP Configuration Tool for FX5-ENET/IP, and rewrite the parameter to the module.
126H	EPIC error	An incorrect RegisterSession command has been received.	<ul style="list-style-type: none"> • Check whether the operating status of the external device is normal. • Check for errors in the line status. • The line may be busy, so retry at a later time.
128H	EPIC error	An incorrect request frame has been received.	<ul style="list-style-type: none"> • Check whether the operating status of the external device is normal. • Check for errors in the line status. • The line may be busy, so retry at a later time.
129H	EPIC error	An incorrect session handle has been received.	<ul style="list-style-type: none"> • Check whether the operating status of the external device is normal. • Check for errors in the line status. • The line may be busy, so retry at a later time.
12AH	EPIC error	Request data with an incorrect size has been received.	<ul style="list-style-type: none"> • Check whether the operating status of the external device is normal. • Check for errors in the line status. • The line may be busy, so retry at a later time.
12BH	EPIC error	Request data including an unsupported protocol version has been received.	<ul style="list-style-type: none"> • Check whether the operating status of the external device is normal. • Check for errors in the line status. • The line may be busy, so retry at a later time.
12DH	EPIC error	Request data with an incorrect size has been received.	<ul style="list-style-type: none"> • Check whether the operating status of the external device is normal. • Check for errors in the line status. • The line may be busy, so retry at a later time.
12EH	Disconnected error	Communications have been disconnected.	Check whether 'EtherNet/IP communication start request' (UnG37.b0) is on.
12FH	System error	The connections have been disconnected.	<ul style="list-style-type: none"> • Check whether the operating status of the external device is normal. • Check for errors in the line status. • The line may be busy, so retry at a later time.
130H to 131H	Connection error	Forward Close has been received from the external device.	<ul style="list-style-type: none"> • Check whether the operating status of the external device is normal. • Check for errors in the line status. • The line may be busy, so retry at a later time.
132H	Memory error	An error was detected in the memory.	<ul style="list-style-type: none"> • Take measures to reduce noise. • Reset the CPU module, and then switch it to RUN mode. If the error occurs again even after the above action is taken, the possible cause is a hardware failure of the module on which the error occurred. Please consult your local Mitsubishi representative.
133H	Disconnected error	Communications have been disconnected.	Check whether 'EtherNet/IP communication start request' (UnG37.b0) is on.
134H	Connection error	A timeout occurred in the connection with the external device.	<ul style="list-style-type: none"> • Check whether the operating status of the external device is normal. • Check for errors in the line status. • The line may be busy, so retry at a later time.
135H	CIP error	A timeout occurred in the connection with the external device.	<ul style="list-style-type: none"> • Check whether the operating status of the external device is normal. • Check for errors in the line status. • The line may be busy, so retry at a later time. • The external device may not be able to send data at the specified RPI due to a high communication load, so specify a larger RPI and connect again.
136H	Connection error	A timeout occurred in the connection with the external device.	<ul style="list-style-type: none"> • Check whether the operating status of the external device is normal. • Check for errors in the line status. • The line may be busy, so retry at a later time.

Error code	Error name	Error details and causes	Action
137H to 138H	Memory error	An error was detected in the memory.	<ul style="list-style-type: none"> • Take measures to reduce noise. • Reset the CPU module, and then switch it to RUN mode. If the error occurs again even after the above action is taken, the possible cause is a hardware failure of the module on which the error occurred. Please consult your local Mitsubishi representative.
17FH	System error	An error was detected in the memory.	<ul style="list-style-type: none"> • Take measures to reduce noise. • Reset the CPU module, and then switch it to RUN mode. If the error occurs again even after the above action is taken, the possible cause is a hardware failure of the module. Please consult your local Mitsubishi representative.
180H to 182H	CIP Extended error	An error notification has been received from the external device.	Refer to documentation such as the manuals of the external device to check the conditions under which a notification is made for this error and the action to take.
183H	CIP Extended error	The external device cannot find the connection to close.	<p>Check the following items, and then restart the EtherNet/IP communications.</p> <ul style="list-style-type: none"> • Is the operating status of the external device normal? • Is the line status normal?
184H to 1A9H	CIP Extended error	An error notification has been received from the external device.	Refer to documentation such as the manuals of the external device to check the conditions under which a notification is made for this error and the action to take.
1AAH	CIP Extended error	An error notification has been received from the external device.	<ul style="list-style-type: none"> • Check whether the operating status of the external device is normal. • Check for errors in the line status. • The line may be busy, so retry at a later time. • Investigate the conditions under which the external device makes a notification for this error, and then take the appropriate measures.
1ABH to 1B3H	CIP Extended error	An error notification has been received from the external device.	Refer to documentation such as the manuals of the external device to check the conditions under which a notification is made for this error and the action to take.
1B4H	CIP Extended error	An error notification has been received from the external device.	<ul style="list-style-type: none"> • Check whether the EtherNet/IP device set with EtherNet/IP Configuration Tool for FX5-ENET/IP matches the external device. • Check whether the EDS file being used matches the external device.
1B5H to 1C7H	CIP Extended error	An error notification has been received from the external device.	Refer to documentation such as the manuals of the external device to check the conditions under which a notification is made for this error and the action to take.
1FFH	CIP Extended error	An error notification has been received from the external device.	Refer to documentation such as the manuals of the external device to check the conditions under which a notification is made for this error and the action to take.
200H to 2FFH	CIP General error	An error notification has been received from the external device.	Refer to documentation such as the manuals of the external device to check the conditions under which a notification is made for this error and the action to take.

Module error

Error codes when a module error occurs are classified into major error, moderate error, and minor error, and can be checked in the [Error Information] tab of the "Module Diagnostics" window of the FX5-ENET/IP. (Page 111 Module diagnostics)
The error codes are stored in 'Latest error code' (Un\G29).

Error code	Error name	Error details and causes	Action
0800H	Link-down	Link-down due to disconnection of the network cable connected to an external device.	<ul style="list-style-type: none"> Check the operation of the external device. Check if the connection cable is disconnected.
0904H	Socket communication sending failure	Socket communication send message fails.	<ul style="list-style-type: none"> Check the operation of the external device. Check if the connection cable is disconnected.
0910H	Ethernet port error	Data cannot be sent to the external device.	<ul style="list-style-type: none"> Check the operation of the external device. Check the conditions of the cables, hubs and routers on the lines to the external devices. The line may be flooded with packets. Retry after a while. The receiving area of the external device may be full (the window size of TCP is small). Confirm whether the receiving processing is performed on the external device side or unnecessary data is not sent from the FX5-ENET/IP. Confirm whether the subnet mask pattern and default router IP address are set correctly on the FX5-ENET/IP and external device or the IP address class is correct.
0911H	Ethernet port error	Communication with the external device was interrupted.	<ul style="list-style-type: none"> Check the operation of the external device. Check the conditions of the cables, hubs and routers on the lines to the external devices. This error may occur when the connection under communication is forcibly invalidated. In this case, there is no problem. Re-connect.
0912H	Ethernet port error	System error or connection connecting error in OS (Malfunction due to noise or hardware trouble may have occurred.)	<ul style="list-style-type: none"> Check the operation of the external device. Check the conditions of the cables, hubs and routers on the lines to the external devices. This error may occur when the connection under communication is forcibly invalidated. In this case, there is no problem. Re-connect.
0913H	Ethernet port error	The external device cannot be connected or is disconnected.	<ul style="list-style-type: none"> Check the operation of the external device. Check the conditions of the cables, hubs and routers on the lines to the external devices. If this error occurs during communication, retry after a while.
1080H	ROM write count error	The number of writes to ROM exceeded 100000. (Number of writes > 100000)	Replace the module.
1810H	IP address change fails	IP address change fails.	Execute the IP address change function again.
1811H to 1812H	Parameter write fails	An error has occurred during writing of parameters.	Rewrite the EtherNet/IP parameters with EtherNet/IP Configuration Tool for FX5-ENET/IP.
1852H	Out-of-range setting error	The property value set in the buffer memory is incorrect.	Confirm that an incorrect value is not stored.
1861H	Excess of sent packet size	The data in the transmitted packet exceeded the size that can be transmitted by one packet.	<ul style="list-style-type: none"> Check the settings for the BACnet device of the communication destination. Confirm the causes of increase in packet size.
1870H	Received protocol version error	The protocol version of NPDU was not 1.	<ul style="list-style-type: none"> Check the specifications of the communication destination device. Check the communication packet.
1871H	Received BVLL (BVLC type) error	Unsupported BVLL (BVLC type) was received.	<ul style="list-style-type: none"> Check the communication packet. Confirm with the manufacturer of the communication destination device.
1872H	Received BVLL (BVLC function) error	Unsupported BVLL (BVLC function) was received.	<ul style="list-style-type: none"> Check the communication packet. Confirm with the manufacturer of the communication destination device.
1873H	Received DNET error	0 was specified for DNET of the received packet.	<ul style="list-style-type: none"> Check the specifications of the communication destination device. Check the communication packet.
1874H	Received SNET error	0 or 65535 was specified for SNET of the received packet.	<ul style="list-style-type: none"> Check the specifications of the communication destination device. Check the communication packet.
1875H	Received SLEN error	0 was specified for SLEN of the received packet.	<ul style="list-style-type: none"> Check the specifications of the communication destination device. Check the communication packet.
1876H	Packet decoding error	An error occurred during packet decoding.	<ul style="list-style-type: none"> Check the communication packet. Please confirm with the manufacturer of the communication destination device.

Error code	Error name	Error details and causes	Action
1877H	Receipt of message that is not supposed to be received	SimpleAck, ComplexAck, SegmentAck, Error response, Reject response or Abort response was received.	<ul style="list-style-type: none"> • Check the communication packet. • Please confirm with the manufacturer of the communication destination device.
1900H	Hardware error	An memory check error has occurred.	<ul style="list-style-type: none"> • Execute the IP address change function again. • If the error occurs again even after the above action is taken, the possible cause is a hardware failure of the module on which the error occurred. Please consult your local Mitsubishi representative.
1901H to 1902H	Hardware error	An memory check error has occurred.	<ul style="list-style-type: none"> • Execute the hardware test. • If the error occurs again even after the above action is taken, the possible cause is a hardware failure of the module on which the error occurred. Please consult your local Mitsubishi representative.
1903H	Hardware error	An memory check error has occurred.	<ul style="list-style-type: none"> • Execute Set Attribute for the CIP object^{*1} with Online Action of EtherNet/IP Configuration Tool for FX5-ENET/IP. • If the error occurs again even after the above action is taken, the possible cause is a hardware failure of the module on which the error occurred. Please consult your local Mitsubishi representative.
1904H	Hardware error	An memory check error has occurred.	<ul style="list-style-type: none"> • Rewrite the EtherNet/IP parameters (EipConfData.BIN), or configuration information (configuration.apa) with EtherNet/IP Configuration Tool for FX5-ENET/IP. • If the error occurs again even after the above action is taken, the possible cause is a hardware failure of the module on which the error occurred. Please consult your local Mitsubishi representative.
1920H ^{*2}	IP address change fails	IP address setting or other (Un\G50 to Un\G55) value exceeds the setting range.	Correct the IP address setting or other (Un\G50 to Un\G55) value.
1921H ^{*3}	IP address change fails	Write request and clear request (Un\G56 and Un\G58) turned from OFF to ON simultaneously.	Check if write request and clear request (Un\G56 and Un\G58) turned from OFF to ON simultaneously.
1D80H	Error during execution of dedicated instruction	An instruction other than executable dedicated instruction numbers has been specified.	Check that the dedicated instruction is executable. If it is not executable, correct.
1D83H	Error during execution of dedicated instruction	The dedicated instruction request data from the CPU module was discarded because the data size was abnormal.	<ul style="list-style-type: none"> • Execute the write to program again. • If the error occurs again even after the above action is taken, the possible cause is a hardware failure of the module on which the error occurred. Please consult your local Mitsubishi representative.
1D84H	Error during execution of dedicated instruction	The dedicated instruction request data from the CPU module cannot be normally input.	<ul style="list-style-type: none"> • Execute the write to program again. • If the error occurs again even after the above action is taken, the possible cause is a hardware failure of the module on which the error occurred. Please consult your local Mitsubishi representative.
1D85H	Error during execution of dedicated instruction	A timeout error occurred in the dedicated instruction response data, and the data was discarded.	<ul style="list-style-type: none"> • Reset the CPU module, and execute again. • If the error occurs again even after the above action is taken, the possible cause is a hardware failure of the module on which the error occurred. Please consult your local Mitsubishi representative.
1DC4H	IP address change fails	IP address change fails.	<ul style="list-style-type: none"> • Execute the IP address change function again. • If the error occurs again even after the above action is taken, the possible cause is a hardware failure of the module on which the error occurred. Please consult your local Mitsubishi representative.
1E10H	EtherNet/IP communication error	An error was detected in the parameters set with EtherNet/IP Configuration Tool for FX5-ENET/IP.	<ul style="list-style-type: none"> • Use EtherNet/IP Configuration Tool for FX5-ENET/IP to write the parameters to the module again. • If the error occurs again even after the above action is taken, the possible cause is a hardware failure of the module on which the error occurred. Please consult your local Mitsubishi representative.
1E11H	EtherNet/IP communication error	An error was detected in the parameters set with EtherNet/IP Configuration Tool for FX5-ENET/IP.	<ul style="list-style-type: none"> • Use EtherNet/IP Configuration Tool for FX5-ENET/IP to write the parameters to the module again. • If the error occurs again even after the above action is taken, the possible cause is a hardware failure of the module on which the error occurred. Please consult your local Mitsubishi representative.
1E12H	EtherNet/IP communication error	An error was detected in the parameters set with EtherNet/IP Configuration Tool for FX5-ENET/IP.	<ul style="list-style-type: none"> • Use EtherNet/IP Configuration Tool for FX5-ENET/IP to write the parameters to the module again. • If the error occurs again even after the above action is taken, the possible cause is a hardware failure of the module on which the error occurred. Please consult your local Mitsubishi representative.
1E13H	EtherNet/IP communication error	It was not possible to stop EtherNet/IP communications.	<ul style="list-style-type: none"> • Check the settings of the connection with the external device. • If the error occurs again even after the above action is taken, the possible cause is a hardware failure of the module on which the error occurred. Please consult your local Mitsubishi representative.

Error code	Error name	Error details and causes	Action
1E14H	EtherNet/IP communication error	It was not possible to stop EtherNet/IP communications.	<ul style="list-style-type: none"> Check the settings of the connection with the external device. If the error occurs again even after the above action is taken, the possible cause is a hardware failure of the module on which the error occurred. Please consult your local Mitsubishi representative.
1F00H	MELSOFT communication error	A communication error occurred in MELSOFT connection.	<ul style="list-style-type: none"> Check the number of connected connections in the whole MELSOFT connection. Check the number of UDP connections in the MELSOFT connection.
2160H	IP address duplication detection	Overlapping IP addresses were detected.	Correct the IP address.
2C80H	Parameter error	A parameter error was detected in the external device configuration.	<ul style="list-style-type: none"> Check the external device configuration settings in the FX5-ENET/IP equipped module parameters. If the same error is displayed again, the abnormal module may have a hardware problem. Please consult your local Mitsubishi representative.
2C81H	Parameter error	A parameter error was detected in the external device configuration.	<ul style="list-style-type: none"> Check the external device configuration settings in the FX5-ENET/IP equipped module parameters. Set so that the sum of the number of connections in External Device Configuration and the number of settings in the simple CPU communication settings is 32 or less. If the same error is displayed again, the abnormal module may have a hardware problem. Please consult your local Mitsubishi representative.
2C82H	Parameter error	A parameter error was detected in the external device configuration.	<ul style="list-style-type: none"> Check the external device configuration settings in the FX5-ENET/IP equipped module parameters. If the same error is displayed again, the abnormal module may have a hardware problem. Please consult your local Mitsubishi representative.
2CF0H	CPU module error	A error of CPU module was detected.	Check the details of the error of the CPU module with the module diagnostics of GX Works3, and take measures.
2DA0H to 2DA1H	Parameter error	A parameter error in external device configuration was detected.	Reexamine and correct the setting of the number of connected units in external device configuration in the FX5-ENET/IP module parameters.
2DA2H	Parameter error	A parameter error in external device configuration was detected.	Reexamine and correct the setting of the communication method in external device configuration in the FX5-ENET/IP module parameters.
2DA3H	Parameter error	A parameter error in external device configuration was detected.	Reexamine and correct the setting of the protocol in external device configuration in the FX5-ENET/IP module parameters.
2DA4H	Parameter error	A parameter error in external device configuration was detected.	Reexamine and correct the setting of the model name in external device configuration in the FX5-ENET/IP module parameters.
2DA5H	Parameter error	A parameter error in external device configuration was detected.	Reexamine and correct the setting of the fixed buffer transmission in external device configuration in the FX5-ENET/IP module parameters.
2DA6H	Parameter error	A parameter error in external device configuration was detected.	Reexamine and correct the setting of the IP address in external device configuration in the FX5-ENET/IP module parameters.
2DA7H	Parameter error	A parameter error in external device configuration was detected.	Reexamine and correct the setting of the IP address (IPv6) in external device configuration in the FX5-ENET/IP module parameters.
2DA8H	Parameter error	A parameter error in external device configuration was detected.	Reexamine and correct the setting of the existence confirmation in external device configuration in the FX5-ENET/IP module parameters.
2DA9H to 2DAAH	Parameter error	A parameter error in external device configuration was detected.	Check the setting of External device configuration in the FX5-ENET/IP module parameters.
2DABH	Parameter error	A parameter error was detected in the external device configuration.	Check the own node port number setting in External Device Configuration FX5-ENET/IP Module Parameter.
2DB0H	Request data error	Request and setting data error	Check the content of the specified request data.
3030H	Hardware error	Hardware error	Please consult your local Mitsubishi representative.
3040H	Update error	F/W update file version error	For this update, a PLC applicable to the new version is required. Please consult your local Mitsubishi representative.
3041H	Update error	F/W update file integrity verification failure error	Replace the update file in the SD memory card with the correct file, and perform update again.
3042H	Update error	F/W update file acquisition failure	Replace the update file in the SD memory card with the correct file, and perform update again.

Error code	Error name	Error details and causes	Action
3056H	Socket communication buffer full	The socket communication buffer for receiving has no space.	Read out the received data using the dedicated instruction.
3095H	Parameter error	The number of target IP address setting is outside the range.	Please consult your local Mitsubishi representative.
3096H	Parameter error	The start target IP address setting is outside the range.	Please consult your local Mitsubishi representative.
3097H	Parameter error	The complete target IP address setting is outside the range.	Please consult your local Mitsubishi representative.
3098H	Parameter error	The start target IP address setting is outside the range > the complete target IP address setting is outside the range	Please consult your local Mitsubishi representative.
3099H	Parameter error	The number of excluded IP address setting is outside the range.	Please consult your local Mitsubishi representative.
309AH	Parameter error	The target IP address setting number is outside the range.	Please consult your local Mitsubishi representative.
309BH	Parameter error	The excluded IP address number is outside the range.	Please consult your local Mitsubishi representative.
309CH	Parameter error	The excluded IP address is outside the range.	Please consult your local Mitsubishi representative.
309DH to 309EH	Parameter error	Target module support error	Please consult your local Mitsubishi representative.
309FH	Parameter error	Gateway address (Ipv6) out of range	Please consult your local Mitsubishi representative.
30AAH	Parameter error	Simple CPU communication parameter out of range	Please consult your local Mitsubishi representative.
3CF1H	Hardware error	An error of hardware was detected.	Please consult your local Mitsubishi representative.
3E30H to 3E42H	Hardware error	An error of hardware was detected.	Please consult your local Mitsubishi representative.
3E50H to 3E56H	Hardware error	An error of hardware was detected.	Please consult your local Mitsubishi representative.
3E60H to 3E63H	Hardware error	An error of hardware was detected.	Please consult your local Mitsubishi representative.
3F92H	Memory error	An error was detected in the memory.	<ul style="list-style-type: none"> Take measures to reduce noise. Reset the CPU module, and then switch it to RUN mode. If the error occurs again even after the above action is taken, the possible cause is a hardware failure of the CPU module. Please consult your local Mitsubishi representative.
3FA1H	Memory error	An error was detected in the memory.	<ul style="list-style-type: none"> Take measures to reduce noise. Reset the CPU module, and then switch it to RUN mode. If the error occurs again even after the above action is taken, the possible cause is a hardware failure of the CPU module. Please consult your local Mitsubishi representative.
4030H	Device specification error	The specified device name cannot be handled.	Check the specified device name.
4031H	Device specification error	<ul style="list-style-type: none"> The specified device No. is out of the range. The external device does not correspond to the specified device name. 	<ul style="list-style-type: none"> Check the specified device No. Check the external device allocation. Check the specified device name.
4032H	Device specification error	A device name (TS, TC, SS, SC, CS or CC) that cannot be used for SLMP random reading/writing (in word units) was specified.	<ul style="list-style-type: none"> Check the specified device modification method. Check the specified device name.
4033H	Device specification error	The specified device is for the system, and data cannot be written.	Do not write data into the specified device or turn ON or OFF the device.
4041H	Intelligent function module specification error	The access range exceeds the buffer memory range of the specified intelligent function module.	Check the starting address and the number of access points, and access within the buffer memory range existing in the intelligent function module.
4043H	Intelligent function module specification error	The specified intelligent function module does not exist.	Check the module number of the specified intelligent function module.

*1 Class: 0x00F5
Instanc: 1
Attribute: 13
Name: Encapsulation Inactivity Timeout

*2 Cannot be checked in the "Module Diagnostics" window and 'Latest error code' (Un\G29). The error codes are stored only in 'IP address storage area write error code' (Un\G61).

*3 Cannot be checked in the "Module Diagnostics" window and 'Latest error code' (Un\G29). The error codes are stored only in 'IP address storage area clear error code' (Un\G62).

Ethernet communication error

The Ethernet communication error codes can be checked in "Status of Each Connection" on the "Ethernet Diagnostics" screen of FX5-ENET/IP. (Page 114 Status of Each Connection) The error codes will be stored in 'Error code' (Un\G108 to Un\G139).

Error code	Error name	Error details and causes	Action
C012H	Error during execution of dedicated instruction	<ul style="list-style-type: none"> The port number already used in the open completion connection of TCP/IP is set. The external device port No. set in the external device information is duplicated. 	Check and correct the port number of the Ethernet module and the target device.
C013H	Error during execution of dedicated instruction	The port number used in the open completion connection is set during the open processing of UDP/IP.	Check and correct the port number of the Ethernet module.
C017H	Error during execution of dedicated instruction	The connection was not established by the open processing of the TCP connection.	<ul style="list-style-type: none"> Check the operation of the target device. Check the open processing of the target device. Correct the open setting of the communication parameter. Check the port number of the Ethernet module, the IP address/port number of the target device, and the open method. Check if the connection cable is disconnected.
C020H	Error during execution of dedicated instruction	The data length exceeds an allowable range.	<ul style="list-style-type: none"> Correct the data length. If the amount of data to send exceeds the prescribed amount, divide and send the data.
C027H	Error during execution of dedicated instruction	Socket communication send message has failed.	<ul style="list-style-type: none"> Check the operation of the external device or switching hub. Since there may be congestion of packets on the line, send data after a certain period of time. Check if the connection cable is disconnected. Check that there is no connection failure with the switching hub. Execute the communication status test, and if the test was completed with an error, take the corrective action. Execute the module communication test, and check that there is no failure in the module. Check the IP address specified as the target.
C029H	Error during execution of dedicated instruction	Description of control data is not correct.	Correct the descriptions of the control data.
C035H	Ethernet communication error	The existence of the external device could not be confirmed within the response monitor timer value.	<ul style="list-style-type: none"> Check the operation of the external device. Reexamine and change the set values for existence confirmation. Check if the connection cable is disconnected.
C04CH	Ethernet communication error	The data cannot be sent since the internal buffer such as IP header buffer has no space.	Send the same data again, and check the receiving of the response.
C050H	Ethernet communication error	When the communication data code is set to "ASCII", ASCII code data which cannot be converted to binary is received.	<ul style="list-style-type: none"> For communication, set to "Binary" in the communication data code and restart the CPU module. Correct the send data from the target device and send it.
C051H	Ethernet communication error	Maximum number of bit devices for which data can be read/written all at once is outside the allowable range.	Correct number of bit devices that can be read or written all at once, and send to Ethernet module again.
C052H	Ethernet communication error	Maximum number of word devices for which data can be read/written all at once is outside the allowable range.	Correct number of word devices that can read or write all at once, and send to Ethernet module again.
C053H	Ethernet communication error	Maximum number of bit devices for which data can be random read/written all at once is outside the allowable range.	Correct number of bit devices that can be read or written all at random, and send to Ethernet module again.
C054H	Ethernet communication error	Maximum number of word devices for which data can be random read/written all at once is outside the allowable range.	Correct number of word devices that can read or write all at random, and send to Ethernet module again.
C056H	Ethernet communication error	Read or write request exceeds maximum address.	Correct starting address or number of read and write points, and send to Ethernet module again. (Be careful not to exceed the maximum address.)

Error code	Error name	Error details and causes	Action
C057H	Ethernet communication error	The request data length in the SLMP message does not match the number of data in the character section (part of the test).	After reexamining and correcting the content of the text or the request data length in the header, resend the message to the Ethernet module.
C058H	Ethernet communication error	Request data length after ASCII- to-binary conversion does not match the number of data in the character section (part of text).	After reexamining and correcting the content of the text or the request data length in the header, resend the message to the Ethernet module.
C059H	Ethernet communication error	<ul style="list-style-type: none"> • Error in command or subcommand specification. • There is a command or subcommand that cannot be used by the Ethernet module. 	<ul style="list-style-type: none"> • Reconsider request contents. • Send command or subcommand that can be used by the Ethernet module.
C05BH	Ethernet communication error	Ethernet module cannot read or write from/to specified device.	Reconsider device to read or write.
C05CH	Ethernet communication error	Error in request contents. (Reading or writing by bit unit for word device, etc.)	Correct request content, and send to Ethernet module again. (Subcommand correction, etc.)
C05EH	Ethernet communication error	The communication time between the Ethernet module and PLC CPU exceeds the Ethernet monitor timer setting.	<ul style="list-style-type: none"> • Increase the monitor timer setting. • Check the connection between the CPU and Ethernet module.
C05FH	Ethernet communication error	There is a request that cannot be executed for the target CPU module.	<ul style="list-style-type: none"> • Correct network No., request station No., request destination module I/O No., or request destination module station No. • Correct contents of write request and/or read request.
C060H	Ethernet communication error	Error in request contents. (Error in specification of data for bit device, etc.)	Correct request content, and send to Ethernet module again. (Data correction, etc.)
C061H	Ethernet communication error	Request data length does not match the number of data in the character section (part of text).	After reexamining and correcting the content of the text or the request data length in the header, resend the message to the Ethernet module.
C06FH	Ethernet communication error	When the communication data code is set to "Binary", a request message of ASCII is received. (Error history of this error code is registered but no error response returns.)	<ul style="list-style-type: none"> • Sent a request message which is adapted to the setting of the communication data code. • Change to the communication data code which is adapted to the request message.
C0D8H	Ethernet communication error	The number of the specified blocks exceeds the range.	Correct the specified value of for the number of blocks.
C0DEH	Ethernet communication error	Socket communication receive message fails.	<ul style="list-style-type: none"> • Check the operation of the external device or switching hub. • Since there may be congestion of packets on the line, send data after a certain period of time. • Check whether the connection cable is not disconnected. • Check that there is no connection failure with the switching hub. • Execute the communication status test, and if the test was completed with an error, take the corrective action. • Execute the module communication test, and check that there is no failure in the module.
C1A4H	Ethernet communication error	<ul style="list-style-type: none"> • The operator tried to use the Ethernet diagnosis, CC-Link IEF Basic diagnosis or simple CPU communication diagnosis connecting directly to the Ethernet port of the Ethernet module. • A function not supported for the target device was executed. 	Execute the Ethernet diagnosis, CC-Link IEF Basic diagnosis or simple CPU communication diagnosis using the direct connection to the CPU module (built-in Ethernet port).
C1A6H	Ethernet communication error	The specification of the connection No. is not correct.	Specify 1 to 32 for the connection No.
C1A7H	Ethernet communication error	The specified network number is incorrect.	Correct the specified network number.
C1A8H	Ethernet communication error	The specified station number is incorrect.	Correct the specified station number.
C1ADH	Ethernet communication error	The specified data length is incorrect.	Correct the specified data length.
C1B0H	Ethernet communication error	The open processing of the specified connection has been already completed.	Perform the open processing after completing the close processing.
C1B1H	Ethernet communication error	The open processing of the specified connection is not completed.	Perform the open processing.
C1B2H	Ethernet communication error	The specified connection is executing the OPEN/CLOSE instruction.	Execute after the OPEN/CLOSE instruction is completed.

Error code	Error name	Error details and causes	Action
C1B3H	Ethernet communication error	The specified channel is being used by another send/receive instruction.	<ul style="list-style-type: none"> • Change the channel number. • Execute after the send/receive instruction is completed.
C1D3H	Error during execution of dedicated instruction	An instruction not conforming to the specifications of the communication method for the connection was executed.	<ul style="list-style-type: none"> • Check that the dedicated instruction can be executed by the specified communication method. Correct the program if the instruction cannot be executed. • Check that there is no error in the connection specification of the dedicated instruction.
C709H	Ethernet communication error	A communication error occurred in MELSOFT direct connection.	<ul style="list-style-type: none"> • Do not specify the direct connection when MELSOFT is not directly connected. • In the case of direct connection, do not turn OFF or reset the CPU module or disconnect the cable during communication.
CFB0H	Simple CPU communication error	Transmission fails due to retransmission timeout.	<ul style="list-style-type: none"> • Check the operation of the external device. • Check the conditions of the cables, hubs and routers on the lines to the external devices. • Reconsider the communication start wait time. • Reconsider and correct the IP address and Ethernet address of the external device. • Confirm that the external devices have the ARP function, and communicate with an external device that has the ARP function. • When the communication destination is a MODBUS/TCP connection device and the communication pattern is Write, do not specify Input or Input Register for the transfer destination device.
CFB1H	Simple CPU communication error	The external device cannot be connected or is disconnected.	<ul style="list-style-type: none"> • Check whether the connection cable is not disconnected. • Check the conditions of the cables, hubs and routers on the lines to the external devices.
CFB2H	Simple CPU communication error	The specified own station port No. is duplicated.	Reconsider the port No., and prevent duplication.
CFB3H	Simple CPU communication error	A request to the CPU module fails.	<ul style="list-style-type: none"> • Reconsider the monitor time of the CPU response monitor timer. • Reconsider the device/label access service processing setting.
CFB4H	Simple CPU communication error	An abnormal response was received from the external device.	Check the abnormal response code in the buffer memory.
CFB5H	Simple CPU communication error	The frame received from the external device is abnormal.	<ul style="list-style-type: none"> • Check the operation of the external device. • Check the conditions of the cables, hubs and routers on the lines to the external devices.
CFBFH	Simple CPU communication error	Simple CPU communication cannot be performed.	<ul style="list-style-type: none"> • Take measures against noise. • If the same error is displayed after retry, Please consult your local Mitsubishi representative.

10.7 List of Event Code

The following table lists events that occur in the FX5-ENET/IP.

Event code	Event type	Event category	Event status	Detected event	Detailed information		
					Detailed information 1	Detailed information 2	Detailed information 3
0800	System	Error	Minor	Link-down	Operation source information	Communication speed and communication mode	—
0904	System	Error	Minor	Socket communication sending failure	Operation source information	—	—
1080	System	Error	Major	ROM write count error	Number of times information*1	—	—
1810	System	Error	Minor	IP address change fails	—	—	—
1811	System	Error	Minor	Flash memory write error (EtherNet/IP parameter)	—	—	—
1812	System	Error	Minor	FTP response send timeout (EtherNet/IP parameter transfer)	—	—	—
1852	System	Error	Minor	Out-of-range setting error	Buffer memory information	—	Failure information
1900	System	Error	Minor	Flash memory check error (IP address change function sector)	—	—	—
1901	System	Error	Minor	Flash memory check error (Total number sector of writes to memory Flash ROM)	—	—	—
1902	System	Error	Minor	Flash memory check error (Flash memory test sector)	—	—	—
1903	System	Error	Minor	Flash memory check error (TCP Inactivity Timeout sector)	—	—	—
1904	System	Error	Minor	Flash memory check error (EtherNet/IP parameter sector)	—	—	—
1E10	System	Error	Minor	EtherNet/IP communication error	—	—	Failure information
1E11	System	Error	Minor	EtherNet/IP communication error	—	—	—
1E12	System	Error	Minor	EtherNet/IP communication error	—	—	—
1E13	System	Error	Minor	EtherNet/IP communication error	—	—	—
1E14	System	Error	Minor	EtherNet/IP communication error	—	—	—
1F00	System	Error	Minor	MELSOFT connection error	—	—	—
2160	System	Error	Moderate	IP address duplication detection	—	—	Failure information
2C80	System	Error	Moderate	Receive parameter sum value error	—	—	Failure information
2C81	System	Error	Moderate	Receive parameter data error	—	—	Failure information
2C82	System	Error	Moderate	Divided parameter receive error	—	—	Failure information
2CF0	System	Error	Moderate	FX5-ENET/IP WDT error occurs	—	—	Failure information
2DA0	System	Error	Moderate	Connection setting parameter (Error in the number of connection setting)	Parameter information*2	—	Failure information
2DA1	System	Error	Moderate	Connection setting parameter (Connection number error)	Parameter information*2	—	Failure information
2DA2	System	Error	Moderate	Connection setting parameter (Communication destination communication method error)	Parameter information*2	—	Failure information
2DA3	System	Error	Moderate	Connection setting parameter (Protocol system error)	Parameter information*2	—	Failure information
2DA4	System	Error	Moderate	Connection setting parameter (Open system error)	Parameter information*2	—	Failure information

Event code	Event type	Event category	Event status	Detected event	Detailed information		
					Detailed information 1	Detailed information 2	Detailed information 3
2DA5	System	Error	Moderate	Connection setting parameter (Fixed buffer transmitting method error)	Parameter information ^{*2}	—	Failure information
2DA6	System	Error	Moderate	Connection setting parameter (IP address (IPv4) error)	Parameter information ^{*2}	—	Failure information
2DA7	System	Error	Moderate	Connection setting parameter (IP address (IPv6) error)	Parameter information ^{*2}	—	Failure information
2DA8	System	Error	Moderate	Connection setting parameter (Existence confirmation specification error)	Parameter information ^{*2}	—	Failure information
2DA9	System	Error	Moderate	Connection setting parameter (Communication data code error)	Parameter information ^{*2}	—	Failure information
2DAA	System	Error	Moderate	Connection setting parameter (Error in specification of writing during running)	Parameter information ^{*2}	—	Failure information
2DAB	System	Error	Moderate	Connection setting parameter own node port number error	Parameter information	—	—
2DB0	System	Error	Moderate	Request data error	—	—	Failure information
3030	System	Error	Moderate	Specific code error	—	—	—
3040	System	Error	Moderate	Firmware update file version error	—	—	—
3041	System	Error	Moderate	Failure in verification of firmware update file integrity	—	—	—
3042	System	Error	Moderate	Failure in acquisition of firmware update file	—	—	—
3056	System	Error	Moderate	Socket communication buffer full	—	—	Failure information
3095	System	Error	Moderate	The number of target IP address setting is outside the range (IP filter settings)	Parameter information ^{*2}	—	—
3096	System	Error	Moderate	IP address 1 is outside the range (IP filter settings)	Parameter information ^{*2}	—	—
3097	System	Error	Moderate	IP address 2 is outside the range (IP filter settings)	Parameter information ^{*2}	—	—
3098	System	Error	Moderate	IP address 1 \geq IP address 2 error (IP filter settings)	Parameter information ^{*2}	—	—
3099	System	Error	Moderate	The number of excluded IP address setting is outside the range (IP filter settings)	Parameter information ^{*2}	—	—
309A	System	Error	Moderate	The target IP address setting number is outside the range (IP filter settings)	Parameter information ^{*2}	—	—
309B	System	Error	Moderate	The excluded IP address number is outside the range (IP filter settings)	Parameter information ^{*2}	—	—
309C	System	Error	Moderate	The excluded IP address is outside the range (IP filter settings)	Parameter information ^{*2}	—	—
309D	System	Error	Moderate	Target module support error (IP address settings parameter)	Parameter information ^{*2}	—	—
309E	System	Error	Moderate	Target module support error (Gateway address setting parameter)	Parameter information ^{*2}	—	—
309F	System	Error	Moderate	The gateway address (IPv6) is outside the range (Gateway address setting parameter)	Parameter information ^{*2}	—	—
3CF1	System	Error	Major	BINT disconnection detection timeout error	—	—	Failure information
3E30	System	Error	Major	The fixed memory block acquisition/release ID number is invalid	—	—	Failure information
3E31	System	Error	Major	Fixed memory block acquisition/release context error	—	—	Failure information
3E32	System	Error	Major	Error in forced cancellation of waiting for variable memory block acquisition/release	—	—	Failure information

Event code	Event type	Event category	Event status	Detected event	Detailed information		
					Detailed information 1	Detailed information 2	Detailed information 3
3E33	System	Error	Major	Error in forced cancellation of waiting due to reset of fixed memory block acquisition/release object	—	—	Failure information
3E34	System	Error	Major	Fixed memory block acquisition/release parameter error	—	—	Failure information
3E35	System	Error	Major	The variable memory block acquisition/release ID number is invalid	—	—	Failure information
3E36	System	Error	Major	Variable memory block acquisition/release context error	—	—	Failure information
3E37	System	Error	Major	Error in forced cancellation of waiting for variable memory block acquisition/release	—	—	Failure information
3E38	System	Error	Major	Error in forced cancellation of waiting due to reset of variable memory block acquisition/release object	—	—	Failure information
3E39	System	Error	Major	Variable memory block acquisition/release parameter error	—	—	Failure information
3E3A	System	Error	Major	E-mail box transmitting/receiving parameter error	—	—	Failure information
3E3B	System	Error	Major	The e-mail box transmitting/receiving ID number is invalid	—	—	Failure information
3E3C	System	Error	Major	E-mail box transmitting/receiving context error	—	—	Failure information
3E3D	System	Error	Major	Error in forced cancellation of waiting for e-mail box transmitting/receiving	—	—	Failure information
3E3E	System	Error	Major	Semaphore acquisition/release parameter error	—	—	Failure information
3E3F	System	Error	Major	Invalid semaphore acquisition/release ID number	—	—	Failure information
3E40	System	Error	Major	Semaphore acquisition/release context error	—	—	Failure information
3E41	System	Error	Major	Semaphore acquisition/release queueing overflow	—	—	Failure information
3E42	System	Error	Major	Error in forced cancellation of waiting for semaphore acquisition/release	—	—	Failure information
3E50	System	Error	Major	RAM check error	—	—	—
3E51	System	Error	Major	Sum check code error	—	—	—
3E52	System	Error	Major	Flash memory test access error	—	—	—
3E53	System	Error	Major	Flash memory test verification error	—	—	—
3E54	System	Error	Major	Buffer memory access error	—	—	—
3E55	System	Error	Major	BusAsic register read error	—	—	—
3E56	System	Error	Major	Factory test mode error	—	—	—
3E60 to 3E63	System	Error	Major	MPU error	—	—	Failure information
3F92	System	Error	Major	Memory error	—	—	Failure information
3FA1	System	Error	Major	Memory error	—	—	Failure information
C050	System	Error	Minor	Ethernet communication error	Parameter information	—	—
C051	System	Error	Minor	Ethernet communication error	Parameter information	—	—
C052	System	Error	Minor	Ethernet communication error	Parameter information	—	—
C053	System	Error	Minor	Ethernet communication error	Parameter information	—	—
C054	System	Error	Minor	Ethernet communication error	Parameter information	—	—

Event code	Event type	Event category	Event status	Detected event	Detailed information		
					Detailed information 1	Detailed information 2	Detailed information 3
C056	System	Error	Minor	Ethernet communication error	Parameter information	—	—
C057	System	Error	Minor	Ethernet communication error	Parameter information	—	—
C058	System	Error	Minor	Ethernet communication error	Parameter information	—	—
C059	System	Error	Minor	Ethernet communication error	Parameter information	—	—
C05B	System	Error	Minor	Ethernet communication error	Parameter information	—	—
C05C	System	Error	Minor	Ethernet communication error	Parameter information	—	—
C05E	System	Error	Minor	Ethernet communication error	Parameter information	—	—
C05F	System	Error	Minor	Ethernet communication error	Parameter information	—	—
C060	System	Error	Minor	Ethernet communication error	Parameter information	—	—
C061	System	Error	Minor	Ethernet communication error	Parameter information	—	—
C06F	System	Error	Minor	Ethernet communication error	Parameter information	—	—
C0D8	System	Error	Minor	Ethernet communication error	Parameter information	—	—

*1 <Number of times information>

- Number of times (set value)

*2 <Parameter information>

- Parameter storage location
- Parameter type
- (I/O number)
- (Parameter number)
- Parameter item number

APPENDIX

Appendix 1 External Dimensions

This chapter describes the external dimensions of the FX5-ENET/IP.

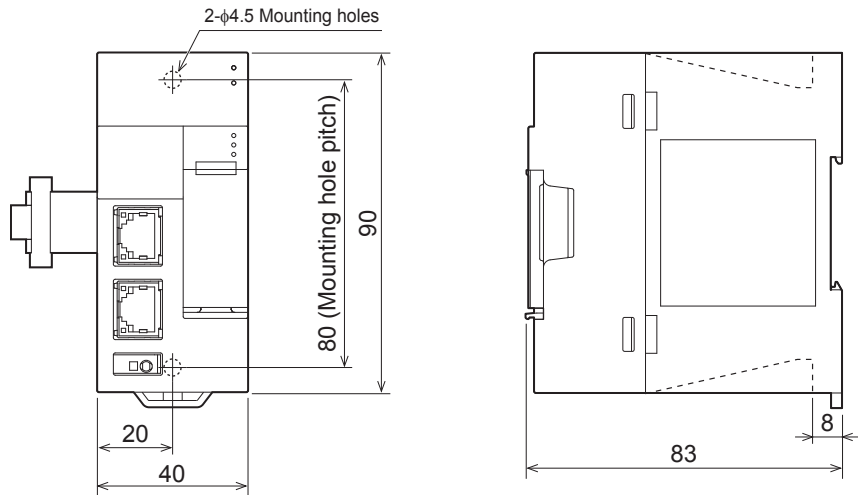

(Unit: mm)

A

Appendix 2 Standards

Certification of UL, cUL standards

The FX5-ENET/IP supports UL (UL, cUL) standards.

UL, cUL file number: E95239

For models that support UL standards, please consult your local Mitsubishi representative.

Compliance with EC Directive (CE marking)

This note does not guarantee that an entire machine produced in accordance with the contents of this note will comply with the following standards.

Compliance to EMC Directive and LVD Directive of the entire mechanical module should be checked by the user/ manufacturer. For more details, please consult your local Mitsubishi representative.

Requirement for compliance with EMC Directive

The following products have shown compliance through direct testing (of the identified standards below) and design analysis (through the creation of a technical construction file) to the European Directive for Electromagnetic Compatibility (2014/30/ EU) when used as directed by the appropriate documentation.

Attention

This product is designed for use in industrial applications.

Product compatibility

Type: Programmable controller (open type equipment)

Models: FX5 manufactured

Electromagnetic compatibility (EMC) directive	Remarks
from October 1st, 2018	FX5-ENET/IP
EN61131-2:2007 Programmable controllers - Equipment requirements and tests	Compliance with all relevant aspects of the standard. EMI • Radiated emission • Conducted emission EMS • Radiated electromagnetic field • Fast transient burst • Electrostatic discharge • High-energy surge • Voltage drops and interruptions • Conducted RF • Power frequency magnetic field

Caution for compliance with EC Directive

Caution for when the FX5-ENET/IP is used

When the FX5-ENET/IP is used, attach a ferrite core and make 2 turns within approximately 200 mm from the power cable connectors. (Ferrite core used in tests by Mitsubishi: E04SR401938 manufactured by SEIWA ELECTRIC MFG. CO., LTD.)

Compliance with UKCA marking

The requirements for compliance with UKCA marking are the same as that with EC directive (CE marking).

Appendix 3 Module Label

The buffer memory of the FX5-ENET/IP can be set using module label.

Structure of the module label

The module label name is defined with the following structure.

- "instance name"_"data format"_"label name"_D
- "instance name"_"data format"_"data type"_"label name"_D

■Instance name

The following is the instance name of the FX5-ENET/IP.

Model	Instance name
FX5-ENET/IP	FX5ENETIP

Ex.

FX5ENETIP_unStatus_LatestError_D

■Data format

The data format indicates the size of a buffer memory area. The following shows the classification.

Data format	Description
b	Bit
bn	Bit of multiple buffer memories
u	Word [Unsigned]/Bit String [16-bit]
ud	Double word [Unsigned]/Bit String [32-bit]
un	Word of multiple buffer memories [Unsigned]/Bit String [16-bit]

■Data type

The data type indicates the type of a buffer memory area. The following shows the classification.

Data type	Description
Val	Display the value of module.
Set	Set the module control instruction.
Sts	Display the module status.

■Label name

A label name unique to the module.

■_D

This symbol indicates that the module label is for direct access. Value update timing is shown below.

Type	Description	Access timing
Direct access	The values read/written from/to the module labels are reflected to the module immediately.	At writing to or reading from the module label



Appendix 4 Buffer Memory

The buffer memory is used to exchange data between the FX5-ENET/IP and the CPU module or EtherNet/IP devices. Buffer memory values are set to their defaults (initial values) when the system is powered off or the CPU module is reset.

List of buffer memory addresses

Buffer memory address		Name	Initial value	Read, write	
Decimal	Hexadecimal				
29	1DH	Latest error code	0	Read	
30	1EH	Module information	69C1H	Read	
31	1FH	Firmware version	*1	Read	
34 to 35	22H to 23H	Input signals	0	Read, write	
36 to 37	24H to 25H	Output signals	0	Read, write	
50 to 51	32H to 33H	IP address setting	0.0.0.0	Read, write	
52 to 53	34H to 35H	Subnet mask pattern setting	0.0.0.0	Read, write	
54 to 55	36H to 37H	Default router IP address setting	0.0.0.0	Read, write	
56	38H	IP address storage area write request	0	Read, write	
57	39H	IP address storage area write status	0	Read	
58	3AH	IP address storage area clear request	0	Read, write	
59	3BH	IP address storage area clear status	0	Read	
60	3CH	IP address change function enable flag	0	Read	
61	3DH	IP address storage area write error code	0	Read	
62	3EH	IP address storage area clear error code	0	Read	
64 to 65	40H to 41H	IP address	192.168.3.251	Read	
74 to 75	4AH to 4BH	Subnet mask pattern	255.255.255.0	Read	
76 to 77	4CH to 4DH	Default gateway IP address	0.0.0.0	Read	
102 to 104	66H to 68H	Ethernet address (MAC address)	*2	Read	
108 to 139	6CH to 8BH	Error code	0	Read	
152 to 153	98H to 99H	Open completion signal	0	Read	
154 to 155	9AH to 9BH	Open request signal	0	Read	
156 to 157	9CH to 9DH	Socket communications receive status signal	0	Read	
158	9EH	Initial status	0	Read	
159	9FH	Initial error code	0	Read	
201	C9H	Same IP address state storage area	0.0.0.0	Read	
202 to 204	CAH to CCH	MAC address of the already connected station	0.0.0.0	Read	
205 to 207	CDH to CFH	MAC address of the station connected later	0.0.0.0	Read	
300, 301	12CH, 12DH	"Communication start at request" request	0	Read, write	
304, 305	130H, 131H	Periodic communication stop request	0	Read, write	
308, 309	134H, 135H	Periodic communication restart request	0	Read, write	
312, 313	138H, 139H	Execution Status flag	0	Read	
316, 317	13CH, 13DH	Ready	0	Read	
320 to 351	140H to 15FH	System area	—	—	
352 to 383	160H to 17FH	Simple CPU communication status	0	Read	
416 to 447	1A0H to 1BFH	Simple CPU error code	0	Read	
480 to 511	1E0H to 1FFH	Abnormal response code	0	Read	
544 to 575	220H to 23FH	Execution interval (current value)	0	Read	
5000	1388H	Block assurance specification per connection	0	Read, write	
5001	1389H	Block assurance state per connection	0	Read	
5004	138CH	EtherNet/IP data link continuation specification	EtherNet/IP data link continuation specification	0	Read, write
5005	138DH		EtherNet/IP data link continuation specification state	0	Read
5006 to 5037	138EH to 13ADH	Class1 I/O data size	Class1 Input data length	0	Read
5070 to 5101	13CEH to 13EDH		Class1 Output data length	0	Read

Buffer memory address		Name		Initial value	Read, write
Decimal	Hexadecimal				
5134 to 5165	140EH to 142DH	Class1 I/O data start offset address	Class1 Start offset address to the input data	65535	Read
5198 to 5229	144EH to 146DH		Class1 Start offset address to the output data	65535	Read
5274 to 5275	149AH to 149BH	Application Trigger	Application Trigger request (UCMM)	0	Read, write
5278 to 5279	149EH to 149FH		Application Trigger acceptance (UCMM)	0	Read
5282 to 5283	14A2H to 14A3H		Application Trigger completion (UCMM)	0	Read
6030 to 6031	178EH to 178FH	Class1 communication status	Data link status	0	Read
6034 to 6035	1792H to 1793H		Error status	0	Read
6262 to 6293	1876H to 1895H	Connection behavior error status	Class1 connection 1 to 32 error code	0	Read
6400 to 8447	1900H to 20FFH	Area for simple CPU communication		—	Read, write
8500	2134H	BACnet communication device	SystemStatus	0	Read, write
8501	2135H		Module status	0	Read
8502 to 8508	2136H to 213CH		Time setting reception	0	Read
8509	213DH		Time setting read flag	0	Read, write
8510	213EH		I-Am transmission	0	Read, write
8520, 8521	2148H, 2149H		BACnet communication Accumulator 1	Object ID	0
8522, 8523	214AH, 214BH	PresentValue		0	Read, write
8524	214CH	OutOfService		0	Read, write
8525	214DH	Reliability		0	Read, write
8526, 8527	214EH, 214FH	Scale		0	Read
8528, 8529	2150H, 2151H	MaxPresValue		0	Read
8530	2152H	Pulse set value		0	Read, write
8531	2153H	Units		0	Read
8540 to 8551	215CH to 2167H	BACnet communication Accumulator 2		Same configuration as BACnet communication Accumulator 1	—
8560 to 8571	2170H to 217BH	BACnet communication Accumulator 3	Same configuration as BACnet communication Accumulator 1	—	—
8580 to 8591	2184H to 218FH	BACnet communication Accumulator 4	Same configuration as BACnet communication Accumulator 1	—	—
8600, 8601	2198H, 2199H	BACnet communication AnalogInput 1	Object ID	0	Read
8602, 8603	219AH, 219BH		PresentValue	0	Read, write
8604	219CH		OutOfService	0	Read, write
8605	219DH		Reliability	0	Read, write
8606	219EH		Units	0	Read
8620 to 8626	21ACH to 21B2H	BACnet communication AnalogInput 2	Same configuration as BACnet communication AnalogInput 1	—	—
8640 to 8646	21C0H to 21C6H	BACnet communication AnalogInput 3	Same configuration as BACnet communication AnalogInput 1	—	—
8660 to 8666	21D4H to 21DAH	BACnet communication AnalogInput 4	Same configuration as BACnet communication AnalogInput 1	—	—
8680 to 8686	21E8H to 21EEH	BACnet communication AnalogInput 5	Same configuration as BACnet communication AnalogInput 1	—	—
8700 to 8706	21FCH to 2202H	BACnet communication AnalogInput 6	Same configuration as BACnet communication AnalogInput 1	—	—
8720 to 8726	2210H to 2216H	BACnet communication AnalogInput 7	Same configuration as BACnet communication AnalogInput 1	—	—
8740 to 8746	2224H to 222AH	BACnet communication AnalogInput 8	Same configuration as BACnet communication AnalogInput 1	—	—



Buffer memory address		Name		Initial value	Read, write
Decimal	Hexadecimal				
8760, 8761	2238H, 2239H	BACnet communication AnalogOutput 1	Object ID	0	Read
8762, 8763	223AH, 223BH		PresentValue	0	Read
8764	223CH		OutOfService	0	Read, write
8765	223DH		Reliability	0	Read, write
8766, 8767	223EH, 223FH		Value set value	0	Read, write
8768	2240H		Write setting	0	Read, write
8769	2241H		Write control	0	Read, write
8770	2242H		Update counter	0	Read
8771	2243H		Units	0	Read
8780 to 8791	224CH to 2257H	BACnet communication AnalogOutput 2	Same configuration as BACnet communication AnalogOutput 1	—	—
8800 to 8811	2260H to 226BH	BACnet communication AnalogOutput 3	Same configuration as BACnet communication AnalogOutput 1	—	—
8820 to 8831	2274H to 227FH	BACnet communication AnalogOutput 4	Same configuration as BACnet communication AnalogOutput 1	—	—
8840 to 8851	2288H to 2293H	BACnet communication AnalogOutput 5	Same configuration as BACnet communication AnalogOutput 1	—	—
8860 to 8871	229CH to 22A7H	BACnet communication AnalogOutput 6	Same configuration as BACnet communication AnalogOutput 1	—	—
8880 to 8891	22B0H to 22BBH	BACnet communication AnalogOutput 7	Same configuration as BACnet communication AnalogOutput 1	—	—
8900 to 8911	22C4H to 22CFH	BACnet communication AnalogOutput 8	Same configuration as BACnet communication AnalogOutput 1	—	—
8920, 8921	22D8H, 22D9H	BACnet communication AnalogValue 1	Object ID	0	Read
8922, 8923	22DAH, 22DBH		PresentValue	0	Read
8924	22DCH		OutOfService	0	Read, write
8925	22DDH		Reliability	0	Read, write
8926, 8927	22DEH, 22DFH		Value set value	0	Read, write
8928	22E0H		Write setting	0	Read, write
8929	22E1H		Write control	0	Read, write
8930	22E2H		Update counter	0	Read
8931	22E3H		Units	0	Read
8940 to 8951	22ECH to 22F7H	BACnet communication AnalogValue 2	Same configuration as BACnet communication AnalogValue 1	—	—
8960 to 8971	2300H to 230BH	BACnet communication AnalogValue 3	Same configuration as BACnet communication AnalogValue 1	—	—
8980 to 8991	2314H to 231FH	BACnet communication AnalogValue 4	Same configuration as BACnet communication AnalogValue 1	—	—
9000 to 9011	2328H to 2333H	BACnet communication AnalogValue 5	Same configuration as BACnet communication AnalogValue 1	—	—
9020 to 9031	233CH to 2347H	BACnet communication AnalogValue 6	Same configuration as BACnet communication AnalogValue 1	—	—
9040 to 9051	2350H to 235BH	BACnet communication AnalogValue 7	Same configuration as BACnet communication AnalogValue 1	—	—
9060 to 9071	2364H to 236FH	BACnet communication AnalogValue 8	Same configuration as BACnet communication AnalogValue 1	—	—
9080, 9081	2378H, 2379H	BACnet communication BinaryInput 1	Object ID	0	Read
9082	237AH		PresentValue	0	Read, write
9083	237BH		OutOfService	0	Read, write
9084	237CH		Reliability	0	Read, write
9100 to 9104	238CH to 2390H	BACnet communication BinaryInput 2	Same configuration as BACnet communication BinaryInput 1	—	—
9120 to 9124	23A0H to 23A4H	BACnet communication BinaryInput 3	Same configuration as BACnet communication BinaryInput 1	—	—
9140 to 9144	23B4H to 23B8H	BACnet communication BinaryInput 4	Same configuration as BACnet communication BinaryInput 1	—	—

Buffer memory address		Name	Initial value	Read, write	
Decimal	Hexadecimal				
9160 to 9164	23C8H to 23CCH	BACnet communication BinaryInput 5	Same configuration as BACnet communication BinaryInput 1	—	
9180 to 9184	23DCH to 23E0H	BACnet communication BinaryInput 6	Same configuration as BACnet communication BinaryInput 1	—	
9200 to 9204	23F0H to 23F4H	BACnet communication BinaryInput 7	Same configuration as BACnet communication BinaryInput 1	—	
9220 to 9224	2404H to 2408H	BACnet communication BinaryInput 8	Same configuration as BACnet communication BinaryInput 1	—	
9240 to 9244	2418H to 241CH	BACnet communication BinaryInput 9	Same configuration as BACnet communication BinaryInput 1	—	
9260 to 9264	242CH to 2430H	BACnet communication BinaryInput 10	Same configuration as BACnet communication BinaryInput 1	—	
9280 to 9284	2440H to 2444H	BACnet communication BinaryInput 11	Same configuration as BACnet communication BinaryInput 1	—	
9300 to 9304	2454H to 2458H	BACnet communication BinaryInput 12	Same configuration as BACnet communication BinaryInput 1	—	
9320 to 9324	2468H to 246CH	BACnet communication BinaryInput 13	Same configuration as BACnet communication BinaryInput 1	—	
9340 to 9344	247CH to 2480H	BACnet communication BinaryInput 14	Same configuration as BACnet communication BinaryInput 1	—	
9360 to 9364	2490H to 2494H	BACnet communication BinaryInput 15	Same configuration as BACnet communication BinaryInput 1	—	
9380 to 9384	24A4H to 24A8H	BACnet communication BinaryInput 16	Same configuration as BACnet communication BinaryInput 1	—	
9400, 9401	24B8H, 24B9H	BACnet communication BinaryOutput 1	Object ID	0	Read
9402	24BAH		PresentValue	0	Read
9403	24BBH		OutOfService	0	Read, write
9404	24BCH		Reliability	0	Read, write
9405	24BDH		Value set value	0	Read, write
9406	24BEH		Write setting	0	Read, write
9407	24BFH		Write control	0	Read, write
9408	24C0H		Update counter	0	Read
9409	24C1H		FeedbackValue	0	Read, write
9420 to 9429	24CCH to 24D5H		BACnet communication BinaryOutput 2	Same configuration as BACnet communication BinaryOutput1	—
9440 to 9449	24E0H to 24E9H	BACnet communication BinaryOutput 3	Same configuration as BACnet communication BinaryOutput1	—	
9460 to 9469	24F4H to 24FDH	BACnet communication BinaryOutput 4	Same configuration as BACnet communication BinaryOutput1	—	
9480 to 9489	2508H to 2511H	BACnet communication BinaryOutput 5	Same configuration as BACnet communication BinaryOutput1	—	
9500 to 9509	251CH to 2525H	BACnet communication BinaryOutput 6	Same configuration as BACnet communication BinaryOutput1	—	
9520 to 9529	2530H to 2539H	BACnet communication BinaryOutput 7	Same configuration as BACnet communication BinaryOutput1	—	
9540 to 9549	2544H to 254DH	BACnet communication BinaryOutput 8	Same configuration as BACnet communication BinaryOutput1	—	
9560 to 9569	2558H to 2561H	BACnet communication BinaryOutput 9	Same configuration as BACnet communication BinaryOutput1	—	
9580 to 9589	256CH to 2575H	BACnet communication BinaryOutput 10	Same configuration as BACnet communication BinaryOutput1	—	
9600 to 9609	2580H to 2589H	BACnet communication BinaryOutput 11	Same configuration as BACnet communication BinaryOutput1	—	
9620 to 9629	2594H to 259DH	BACnet communication BinaryOutput 12	Same configuration as BACnet communication BinaryOutput1	—	
9640 to 9649	25A8H to 25B1H	BACnet communication BinaryOutput 13	Same configuration as BACnet communication BinaryOutput1	—	



Buffer memory address		Name		Initial value	Read, write
Decimal	Hexadecimal				
9660 to 9669	25BCH to 25C5H	BACnet communication BinaryOutput 14	Same configuration as BACnet communication BinaryOutput1	—	—
9680 to 9689	25D0H to 25D9H	BACnet communication BinaryOutput 15	Same configuration as BACnet communication BinaryOutput1	—	—
9700 to 9709	25E4H to 25EDH	BACnet communication BinaryOutput 16	Same configuration as BACnet communication BinaryOutput1	—	—
9720, 9721	25F8H, 25F9H	BACnet communication BinaryValue 1	Object ID	0	Read
9722	25FAH		PresentValue	0	Read
9723	25FBH		OutOfService	0	Read, write
9724	25FCH		Reliability	0	Read, write
9725	25FDH		Value set value	0	Read, write
9726	25FEH		Write setting	0	Read, write
9727	25FFH		Write control	0	Read, write
9728	2600H		Update counter	0	Read
9740 to 9748	260CH to 2614H		BACnet communication BinaryValue 2	Same configuration as BACnet communication BinaryValue 1	—
9760 to 9768	2620H to 2628H	BACnet communication BinaryValue 3	Same configuration as BACnet communication BinaryValue 1	—	—
9780 to 9788	2634H to 263CH	BACnet communication BinaryValue 4	Same configuration as BACnet communication BinaryValue 1	—	—
9800 to 9808	2648H to 2650H	BACnet communication BinaryValue 5	Same configuration as BACnet communication BinaryValue 1	—	—
9820 to 9828	265CH to 2664H	BACnet communication BinaryValue 6	Same configuration as BACnet communication BinaryValue 1	—	—
9840 to 9848	2670H to 2678H	BACnet communication BinaryValue 7	Same configuration as BACnet communication BinaryValue 1	—	—
9860 to 9868	2684H to 268CH	BACnet communication BinaryValue 8	Same configuration as BACnet communication BinaryValue 1	—	—
9880 to 9888	2698H to 26A0H	BACnet communication BinaryValue 9	Same configuration as BACnet communication BinaryValue 1	—	—
9900 to 9908	26ACH to 26B4H	BACnet communication BinaryValue 10	Same configuration as BACnet communication BinaryValue 1	—	—
9920 to 9928	26C0H to 26C8H	BACnet communication BinaryValue 11	Same configuration as BACnet communication BinaryValue 1	—	—
9940 to 9948	26D4H to 26DCH	BACnet communication BinaryValue 12	Same configuration as BACnet communication BinaryValue 1	—	—
9960 to 9968	26E8H to 26F0H	BACnet communication BinaryValue 13	Same configuration as BACnet communication BinaryValue 1	—	—
9980 to 9988	26FCH to 2704H	BACnet communication BinaryValue 14	Same configuration as BACnet communication BinaryValue 1	—	—
10000 to 10008	2710H to 2718H	BACnet communication BinaryValue 15	Same configuration as BACnet communication BinaryValue 1	—	—
10020 to 10028	2724H to 272CH	BACnet communication BinaryValue 16	Same configuration as BACnet communication BinaryValue 1	—	—
10040, 10041	2738H, 2739H	BACnet communication Multi-state Input 1	Object ID	—	Read
10042, 10043	273AH, 273BH		PresentValue	—	Read, write
10044	273CH		OutOfService	—	Read, write
10045	273DH		Reliability	—	Read, write
10046, 10047	273EH, 273FH		NumberOfStates	—	Read
10060 to 10067	274CH to 2753H		BACnet communication Multi-state Input 2	Same configuration as BACnet communication Multi-state Input 1	—
10080 to 10087	2760H to 2767H	BACnet communication Multi-state Input 3	Same configuration as BACnet communication Multi-state Input 1	—	—
10100 to 10107	2774H to 277BH	BACnet communication Multi-state Input 4	Same configuration as BACnet communication Multi-state Input 1	—	—
10120 to 10127	2788H to 278FH	BACnet communication Multi-state Input 5	Same configuration as BACnet communication Multi-state Input 1	—	—

Buffer memory address		Name	Initial value	Read, write	
Decimal	Hexadecimal				
10140 to 10147	279CH to 27A3H	BACnet communication Multi-state Input 6	Same configuration as BACnet communication Multi-state Input 1	—	
10160 to 10167	27B0H to 27B7H	BACnet communication Multi-state Input 7	Same configuration as BACnet communication Multi-state Input 1	—	
10180 to 10187	27C4H to 27CBH	BACnet communication Multi-state Input 8	Same configuration as BACnet communication Multi-state Input 1	—	
10200, 10201	27D8H, 27D9H	BACnet communication Multi-state Output 1	Object ID	0	Read
10202, 10203	27DAH, 27DBH		PresentValue	0	Read
10204	27DCH		OutOfService	0	Read, write
10205	27DDH		Reliability	0	Read, write
10206, 10207	27DEH, 27DFH		Value set value	0	Read, write
10208	27E0H		Write setting	0	Read, write
10209	27E1H		Write control	0	Read, write
10210	27E2H		Update counter	0	Read
10212, 10213	27E4H, 27E5H		FeedbackValue	0	Read, write
10214, 10215	27E6H, 27E7H		NumberOfStates	0	Read
10220 to 10230, 10232 to 10235	27ECH to 27F6H, 27F8H to 27FBH		BACnet communication Multi-state Output 2	Same configuration as BACnet communication Multi-state Output 1	—
10240 to 10250, 10252 to 10255	2800H to 280AH, 280CH to 280FH	BACnet communication Multi-state Output 3	Same configuration as BACnet communication Multi-state Output 1	—	
10260 to 10270, 10272 to 10275	2814H to 281EH, 2820H to 2823H	BACnet communication Multi-state Output 4	Same configuration as BACnet communication Multi-state Output 1	—	
10280 to 10290, 10292 to 10295	2828H to 2832H, 2834H to 2837H	BACnet communication Multi-state Output 5	Same configuration as BACnet communication Multi-state Output 1	—	
10300 to 10310, 10312 to 10315	283CH to 2846H, 2848H to 284BH	BACnet communication Multi-state Output 6	Same configuration as BACnet communication Multi-state Output 1	—	
10320 to 10330, 10332 to 10335	2850H to 285AH, 285CH to 285FH	BACnet communication Multi-state Output 7	Same configuration as BACnet communication Multi-state Output 1	—	
10340 to 10350, 10352 to 10355	2864H to 286EH, 2870H to 2873H	BACnet communication Multi-state Output 8	Same configuration as BACnet communication Multi-state Output 1	—	
11434 to 11465	2CAAH to 2CC9H	Block assurance specification per connection	Connection 1 to 32 input data update state	0	Read, write
11498 to 11529	2CEAH to 2D09H		Connection 1 to 32 output data update state	0	Read, write
12000 to 35999	2EE0H to 8C9FH	Class1 communications input data area		0	Read
36000 to 59999	8CA0H to EA5FH	UCMM communications input data area		0	Read
60000 to 83999	EA60H to 1481FH	Class1 communications output data area		0	Read, write
84000 to 107999	14820H to 1A5DFH	UCMM communications output data area		0	Read, write

*1 The firmware version of the FX5-ENET/IP is stored. For Ver. 1.000, 1000 is stored.

*2 MAC address written before shipment



Details of buffer memory addresses

The following describes the buffer memory addresses of the FX5-ENET/IP.

For the details of the buffer memory (Un\8500 to Un\10355) of the BACnet function, refer to  MELSEC iQ-F FX5 User's Manual (BACnet).

Latest error code

■Latest error code (Un\G29)

The latest error code that has occurred in FX5-ENET/IP is stored. (0 is stored when communications are normal.)

For details on error code, refer to  Page 128 Module error.

Module information

■Module information (Un\G30)

This area stores the module information (69C1H) of FX5-ENET/IP.

Firmware version

■Firmware version (Un\G31)

This area stores the firmware version of FX5-ENET/IP.

Ex.

When firmware version of the FX5-ENET/IP is Ver. 1.000: K1000

Input signals

■Input signals (Un\G34 to Un\G35)

These signals are used to check the status of FX5-ENET/IP.

Address	bit	Signal name	Description
Un\G34	b0	Module ready	A signal for checking the status of completion of preparation for operation of FX5-ENET/IP. • On: The module is operable • Off: The module is not operable (in preparation)
	b15	Module error status	A signal for checking the occurrence of error (minor/moderate/major) of FX5-ENET/IP • On: An error has occurred (minor/moderate/major) • Off: No error When the signal is turned on (an error occurs), remove the cause of the error, and turn on 'Module error clear request' (Un\G36.b15). Then, the signal will be turned off.
Un\G35	b0	EtherNet/IP communication in process	A signal for checking whether the EtherNet/IP communication has started. • On: Starting • Off: Stopped

Output signals

■ Output signals (Un\G36 to Un\G37)

These signals are used for controlling the FX5-ENET/IP.

Address	bit	Signal name	Description
Un\G36	b15	Module error clear request	Requests to clear the error that has occurred in FX5-ENET/IP. To request to clear the module error, turn off, on and off the signal. Issuing the request after the cause of the error is removed will clear the followings. <ul style="list-style-type: none"> • 'Module error status' (Un\G34.b15) is turned on and on. • The ERROR LED is turned off. • The following buffer memory <ul style="list-style-type: none"> - 'Latest error code' (Un\G29) - 'IP address storage area write error code' (Un\G61) - 'IP address storage area clear error code' (Un\G62) - 'Error code' (Un\G108 to Un\G139) - 'Same IP address state storage area' (Un\G201) - 'MAC address of the already connected station' (Un\G202 to Un\G204) - 'MAC address of the station connected later' (Un\G205 to Un\G207)
Un\G37	b0	EtherNet/IP communication start request	Requests to start or stop the EtherNet/IP communication. <ul style="list-style-type: none"> • Start request: Off to on • Stop request: On to off For the operation timing of EtherNet/IP communications, refer to Page 150 Operation timing of EtherNet/IP communications.

Point

- Turn on and off the 'module error clear request' (Un\G36.b15) at the following timing using the 'Module error clear request' (Un\G36.b15) as an interlock condition. (In the case of Class1 communication)

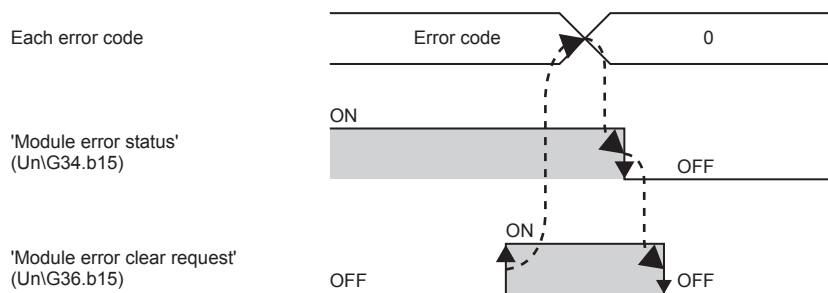

- To start the UCMM communication, an application trigger is required. (Page 161 Application Trigger)

A

■ Operation timing of EtherNet/IP communications

The operation timing of the EtherNet/IP communication by turning on 'Operation is in progress with the setting for continuing EtherNet/IP communications' (Un\G37.b0) is shown below.

When 'EtherNet/IP data link continuation specification state' (Un\G5005) is "1: Operation is in progress with the setting for continuing EtherNet/IP communications," the EtherNet/IP communication will be continued even if 'EtherNet/IP communication start request' (Un\G37.b0) is turned on and off. (☞ Page 40 EtherNet/IP Communication Functions)

- EtherNet/IP communication has started (normal)

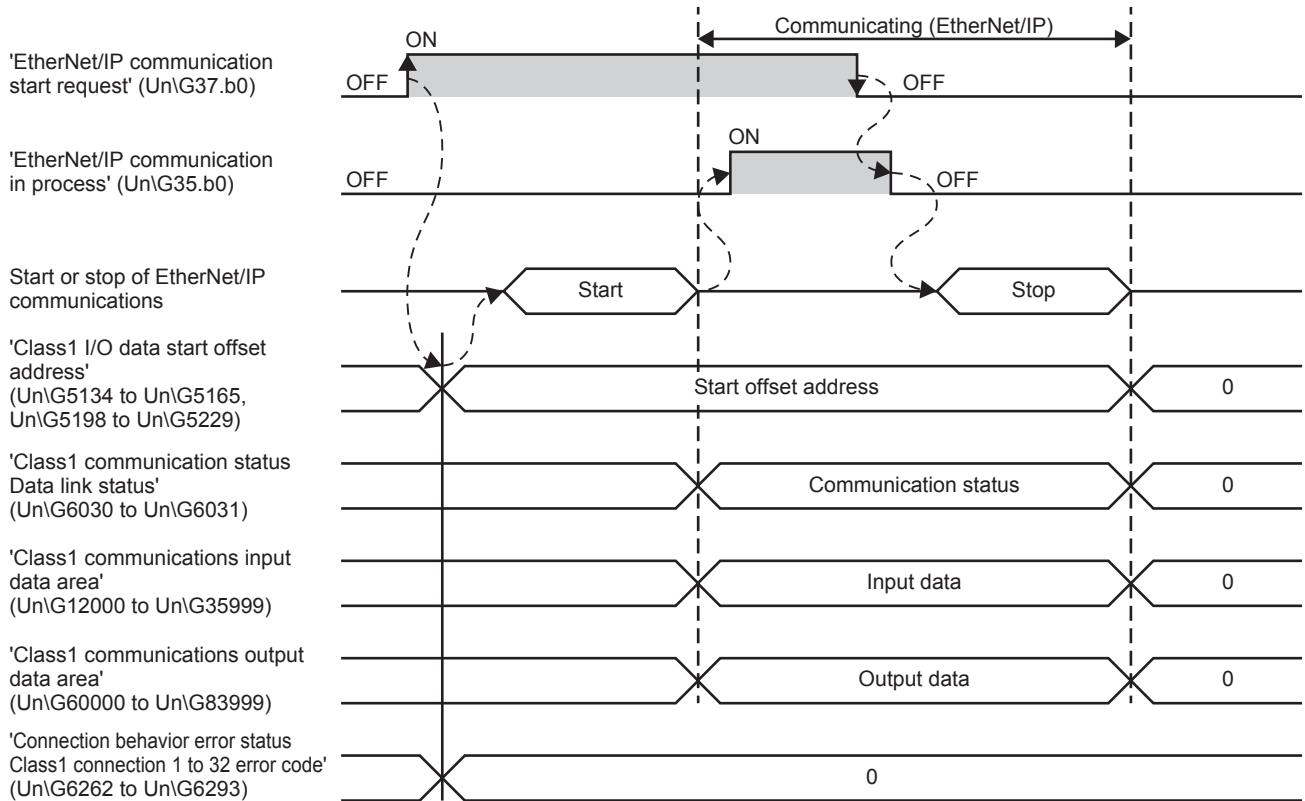

- EtherNet/IP communication does not start (error)

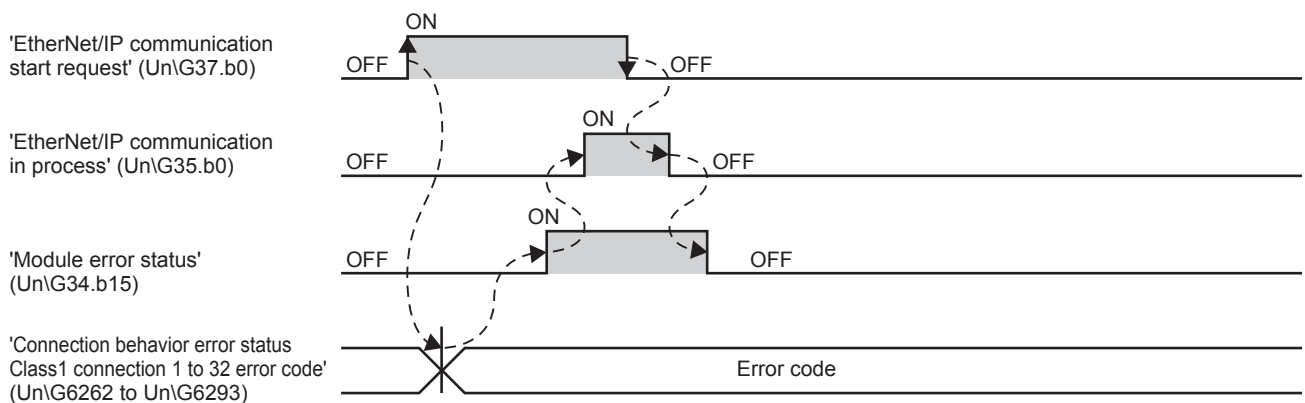

- 'EtherNet/IP data link continuation specification' (Un\G5004) is set

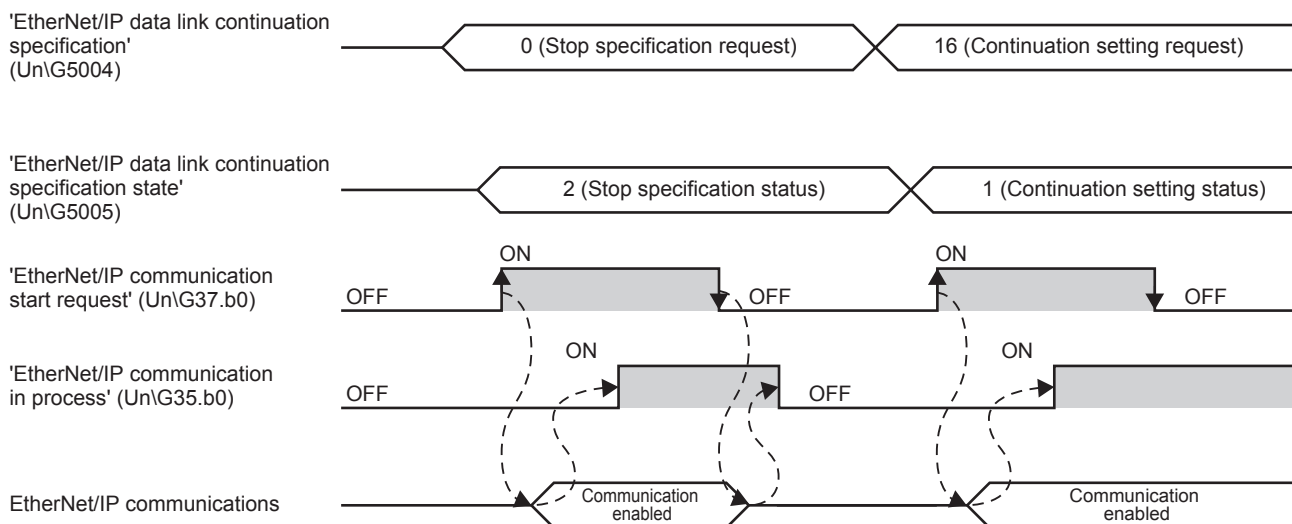

IP address setting

■IP address setting (Un\G50 to Un\G51)

Stores IP address to be set when using IP address change function.

Stores 0 when writing to IP address storage area is completed normally.

Address	Description
Un\G50	3rd octet, 4th octet
Un\G51	1st octet, 2nd octet

Ex.

When IP address is 192.168.3.250: Un\G50 = H03FA, Un\G51 = HC0A8

Subnet mask pattern setting

■Subnet mask pattern setting (Un\G52 to Un\G53)

Stores subnet mask pattern to be set when using IP address change function.

Stores 0 when writing to IP address storage area is completed normally.

Address	Description
Un\G52	3rd octet, 4th octet
Un\G53	1st octet, 2nd octet

Ex.

When subnet mask pattern is 255.255.255.0: Un\G52 = HFF00, Un\G53 = HFFFF

Default router IP address setting

■Default router IP address setting (Un\G54 to Un\G55)

Stores default router IP address to be set when using IP address change function.

Stores 0 when writing to IP address storage area is completed normally.

Address	Description
Un\G54	3rd octet, 4th octet
Un\G55	1st octet, 2nd octet

Ex.

When default router IP address is 192.168.3.255: Un\G54 = H03FF, Un\G55 = HC0A8

IP address storage area write request

■IP address storage area write request (Un\G56)

Specify whether to write the stored values of 'IP address setting' (Un\G50 to Un\G51), 'Subnet mask pattern setting' (Un\G52 to Un\G53) and 'Default router IP address setting' (Un\G54 to Un\G55) to the IP address storage area.

- 0: Not write
- 1: Write

IP address storage area write status

■IP address storage area write status (Un\G57)

You can confirm whether or not the values are written to the IP address storage area when executing the IP address change function.

Address	bit	Name	Description
Un\G57	b0	IP address storage area write completed	Turns ON when writing to IP address storage area completes or fails. Turns off when 'IP address storage area write request' (Un\G56) is changed from 1 to 0.
	b1	IP address storage area write error	Turns ON when writing to IP address storage area fails. Turns ON if there is a problem in contents of IP address storage area, when Ethernet module power supply is turned from OFF to ON. Turns off when 'IP address storage area write request' (Un\G56) is changed from 1 to 0.

IP address storage area clear request

■IP address storage area clear request (Un\G58)

Specify whether to clear the data in the IP address storage area.

- 0: Not clear
- 1: Clear

IP address storage area clear status

■IP address storage area clear status (Un\G59)

You can confirm whether or not the IP address storage area is cleared.

Address	bit	Name	Description
Un\G59	b0	IP address storage area clear completed	Turns ON when clearing of IP address storage area completes or fails. Turns off when 'IP address storage area clear request' (Un\G58) is changed from 1 to 0.
	b1	IP address storage area clear error	Turns ON when clearing of IP address storage area fails. Turns off when 'IP address storage area clear request' (Un\G58) is changed from 1 to 0.

IP address change function enable flag

■IP address change function enable flag (Un\G60)

You can confirm whether or not the IP address change function is enabled.

- 0: Invalid
- 1: Enable

IP address storage area write error code

■IP address storage area write error code (Un\G61)

Stores error codes if writing to IP address storage area fails.

- 0: Normal (no error)
- 1920H: Values of IP address setting, etc. (Un\G50 to Un\G55) are out of the setting ranges

IP address storage area clear error code

■IP address storage area clear error code (Un\G62)

Stores error codes if clearing of IP address storage area fails.

- 0: Normal (no error)
- 1921H: 'IP address storage area write request' (Un\G56) and 'IP address storage area clear request' (Un\G58) were simultaneously turned off and on.

IP address

■IP address (Un\G64 to Un\G65)

Stores IP address on the own station set with GX Works3. (📖 Page 48 Basic Setting) The stored values can be changed by the IP address change function.

Address	Description
Un\G64	3rd octet, 4th octet
Un\G65	1st octet, 2nd octet

Ex.

When IP address is 192.168.3.250: Un\G64 = H03FA, Un\G65 = HC0A8

Point

If the IP address is changed by the IP address change function, priority will be given to the IP address stored by the IP address change function. To enable the set value in GX Works3, clear the IP address storage area.

Subnet mask pattern

■Subnet mask pattern (Un\G74 to Un\G75)

Stores subnet mask pattern on the own station set with GX Works3. (📖 Page 48 Basic Setting) The stored values can be changed by the IP address change function.

Address	Description
Un\G74	3rd octet, 4th octet
Un\G75	1st octet, 2nd octet

Point

If the subnet mask pattern is changed by the IP address change function, priority will be given to the subnet mask pattern stored by the IP address change function. To enable the set value in GX Works3, clear the IP address storage area.

Ex.

When subnet mask pattern is 255.255.255.0: Un\G74 = HFF00, Un\G75 = HFFFF

Default gateway IP address

■Default gateway IP address (Un\G76 to Un\G77)

Stores default gateway IP address on the own station set with GX Works3. (📖 Page 48 Basic Setting) The stored values can be changed by the IP address change function.

Address	Description
Un\G76	3rd octet, 4th octet
Un\G77	1st octet, 2nd octet

Ex.

When default gateway IP address is 192.168.3.255: Un\G76 = H03FF, Un\G77 = HC0A8

Point

If the default gateway IP address is changed by the IP address change function, priority will be given to the default gateway IP address stored by the IP address change function. To enable the set value in GX Works3, clear the IP address storage area.

Ethernet address (MAC address)

■Ethernet address (MAC address) (Un\G102 to Un\G104)

Stores Ethernet address (MAC address) on the own station.

Address	Stored value
Un\G102	Serial ID
Un\G103	Lower one digit of vendor ID, model ID
Un\G104	Upper two digits of vendor ID

Ex.

When MAC address is 00-26-92-60-10-25: Un\G102 = H1025, Un\G103 = H9260, Un\G104 = H0026

Error code

■Error code (Un\G108 to Un\G139)

Stores error code (connection number 1 to 32) of general-purpose Ethernet. (0 is stored when communications are normal.)

For details on error code, refer to 📖 Page 128 Module error.

Address	Description
Un\G108	Stores error code of connection number 1.
Un\G109	Stores error code of connection number 2.
⋮	
Un\G139	Stores error code of connection number 32.

Open completion signal

■Open completion signal (Un\G152 to Un\G153)

Open completion signal for each connection number.

Address	bit	Connection number	Description
Un\G152	b0	Connection number 1	• On: Open completed • Off: Closed or not open
	b1	Connection number 2	
	⋮		
	b15	Connection number 16	
Un\G153	b0 to b15	Connection number 17 to 32	

Open request signal

■Open request signal (Un\G154 to Un\G155)

Open request signal for each connection number of socket communication.

Address	bit	Connection number	Description
Un\G154	b0	Connection number 1	• On: Requesting open • Off: No open request
	b1	Connection number 2	
	⋮		
	b15	Connection number 16	
Un\G155	b0 to b15	Connection number 17 to 32	

Socket communications receive status signal

■Socket communications receive status signal (Un\G156 to Un\G157)

Socket communication receive state signal for each connection number.

Address	bit	Connection number	Description
Un\G156	b0	Connection number 1	• On: Data reception completed • Off: Data not received
	b1	Connection number 2	
	⋮		
	b15	Connection number 16	
Un\G157	b0 to b15	Connection number 17 to 32	

Initial status

■Initial status (Un\G158)

You can confirm whether or not FX5-ENET/IP has been initialized.

Address	bit	Name	Description
Un\G158	b0	Initial normal completion status	Turns on when the initialization is normally completed.
	b1	Initial abnormal completion status	Turns on when the initialization is abnormally completed.

A

Initial error code

■Initial error code (Un\G159)

The error codes that occur during initialization of FX5-ENET/IP are stored. (0 is stored when communications are normal.)

For details on error code, refer to  Page 128 Module error.

Same IP address state storage area

■Same IP address state storage area (Un\G201)

Same IP address state is stored.

Address	bit	Name	Description
Un\G201	b0	Same IP address detection flag	Turns ON if there is a same IP address.

MAC address of the already connected station

■MAC address of the already connected station (Un\G202 to Un\G204)

Stores the MAC address of the station, which was connected to the network earlier, in the station with duplicated IP address.

Address	Description
Un\G202	Serial ID
Un\G203	Lower one digit of vendor ID, model ID
Un\G204	Upper two digits of vendor ID

Ex.

When MAC address is 00-26-92-60-10-25: Un\G202 = H1025, Un\G203 = H9260, Un\G204 = H0026
"FFFFFFFFFFFFH" is stored in the station that has been already connected to the network.

MAC address of the station connected later

■MAC address of the station connected later (Un\G205 to Un\G207)

Stores the MAC address of the station with duplicated IP address in the station which was connected earlier to the network.

Address	Description
Un\G205	Serial ID
Un\G206	Lower one digit of vendor ID, model ID
Un\G207	Upper two digits of vendor ID

Ex.

When MAC address is 00-26-92-60-10-25: Un\G205 = H1025, Un\G206 = H9260, Un\G207 = H0026
"FFFFFFFFFFFFH" is stored in the station with duplicated IP address.

“Communication start at request” request

■“Communication start at request” request (Un\G300, Un\G301)

When the communication setting is “requested,” start of data transmission in the simple CPU communication is requested.

Address	bit	Setting No.	Description
Un\G300	b0	Setting No.1	• ON: Requested • OFF: Not requested
	b1	Setting No.2	
	⋮		
	b15	Setting No.16	
Un\G301	b0 to b15	Setting No.17 to 32	

Periodic communication stop request

■Periodic communication stop request (Un\G304, Un\G305)

When the communication setting is “Fixed,” stop of data transmission in the simple CPU communication is requested.

Address	bit	Setting No.	Description
Un\G304	b0	Setting No.1	• ON: Requested • OFF: Not requested
	b1	Setting No.2	
	⋮		
	b15	Setting No.16	
Un\G305	b0 to b15	Setting No.17 to 32	

Periodic communication restart request

■Periodic communication restart request (Un\G308, Un\G309)

When the communication setting is “Fixed,” restart of data transmission in the simple CPU communication is requested.

Address	bit	Setting No.	Description
Un\G308	b0	Setting No.1	<ul style="list-style-type: none"> • ON: Requested • OFF: Not requested
	b1	Setting No.2	
	⋮		
	b15	Setting No.16	
Un\G309	b0 to b15	Setting No.17 to 32	

Execution Status flag

■Execution Status flag (Un\G312, Un\G313)

The data transmission/reception status of the simple CPU communication is stored.

Address	bit	Setting No.	Description
Un\G312	b0	Setting No.1	<ul style="list-style-type: none"> • ON: During execution • OFF: Unexecuted
	b1	Setting No.2	
	⋮		
	b15	Setting No.16	
Un\G313	b0 to b15	Setting No.17 to 32	

Ready

■Ready (Un\G316, Un\G317)

The preparation completion status of the simple CPU communication is stored.

Address	bit	Setting No.	Description
Un\G316	b0	Setting No.1	<ul style="list-style-type: none"> • ON: Ready • OFF: Not ready
	b1	Setting No.2	
	⋮		
	b15	Setting No.16	
Un\G317	b0 to b15	Setting No.17 to 32	

Simple CPU communication status

■Simple CPU communication status (Un\G352 to Un\G383)

The simple CPU communication status is stored..

Address	Setting No.	Description
Un\G352	Setting No.1	<ul style="list-style-type: none"> • 0H: Unset • 1H: Preparing • 2H: Waiting for request • 3H: Communicating • 4H: Communication stop • 5H: Retry being executed • 6H: Monitoring • AH: Communications impossible
Un\G353	Setting No.2	
⋮		
Un\G382	Setting No.31	
Un\G383	Setting No.32	

Simple CPU error code

■Simple CPU error code (Un\G416 to Un\G447)

The cause (CFB0H to CFBFH) of the error detected in the simple CPU communication is stored. For the details of the error codes, refer to  Page 117 Ethernet communication error.

Address	Description
Un\G416	The error code of the setting No.1 is stored.
Un\G417	The error code of the setting No.2 is stored.
⋮	
Un\G447	The error code of the setting No.32 is stored.

Abnormal response code

■Abnormal response code (Un\G480 to Un\G511)

The abnormal response code detected in the simple CPU communication is stored.

Address	Description
Un\G480	The abnormal response code of the setting No.1 is stored.
Un\G481	The abnormal response code of the setting No.2 is stored.
⋮	
Un\G511	The abnormal response code of the setting No.32 is stored.

Execution interval (current value)

■Execution interval (current value) (Un\G544 to Un\G575)

The execution interval of the simple CPU is stored.

Address	Description
Un\G544	The execution interval of the setting No.1 is stored.
Un\G545	The execution interval of the setting No.2 is stored.
⋮	
Un\G575	The execution interval of the setting No.32 is stored.

Block assurance specification per connection

■Block assurance specification per connection (Un\G5000)

This address is used to set whether to perform data assurance on the input data or output data used in Class1 communications. ( Page 31 Assurance of input/output data)

The setting is reflected when 'EtherNet/IP communication start request' (Un\G37.b0) is turned off and on.

- 0: Do not perform data assurance.
- 16: Perform data assurance.

Block assurance state per connection

■Block assurance state per connection (Un\G5001)

This address is used to store the data assurance status for the input data or output data of the Class1 communications being executed. ( Page 31 Assurance of input/output data)

The setting is reflected when 'EtherNet/IP communication start request' (Un\G37.b0) is turned off and on.

- 0: EtherNet/IP communication is stopped.
- 1: Data assurance is not being performed.
- 2: Data assurance is being performed.

EtherNet/IP data link continuation specification

■EtherNet/IP data link continuation specification (Un\G5004)

This address is used to set whether to continue EtherNet/IP communications when 'EtherNet/IP communication start request' (Un\G37.b0) is turned on and off. (☞ Page 40 EtherNet/IP Communication Functions)

Set this address to continue EtherNet/IP communications in situations such as when the CPU module changes from the RUN state to the STOP state and when a stop error occurs on the CPU module.

The setting is reflected when 'EtherNet/IP communication start request' (Un\G37.b0) is turned off and on.

- 0: Stops EtherNet/IP communications.
- 16: Continues EtherNet/IP communications.

■EtherNet/IP data link continuation specification state (Un\G5005)

This address is used to store the setting status of 'EtherNet/IP data link continuation specification' (Un\G5004).

The setting is reflected when 'EtherNet/IP communication start request' (Un\G37.b0) is turned off and on.

- 0: The 'EtherNet/IP data link continuation specification' (Un\G5004) setting has not been reflected.
- 1: Operation is in progress with the setting for continuing EtherNet/IP communications.
- 2: Operation is in progress with the setting for stopping EtherNet/IP communications.

When 'EtherNet/IP communication start request' (Un\G37.b0) is turned on and off, or the CPU module switches to STOP state (including STOP by a stop error), the setting is initialized to 0.

Class1 I/O data size

■Class1 Input data length (Un\G5006 to Un\G5037)

This address is used to store the size of the data received by the FX5-ENET/IP from the EtherNet/IP device during Class1 communications. (Unit: words) (☞ Page 87 [Connections] tab)

Address	Description
Un\G5006	Stores the input data size of connection number 1.
Un\G5007	Stores the input data size of connection number 2.
⋮	
Un\G5037	Stores the input data size of connection number 32.

■Class1 Output data length (Un\G5070 to Un\G5101)

This address is used to store the size of the data to send to the EtherNet/IP device from the FX5-ENET/IP during Class1 communications. (Unit: words) (☞ Page 87 [Connections] tab)

Address	Description
Un\G5070	Stores the output data size of connection number 1.
Un\G5071	Stores the output data size of connection number 2.
⋮	
Un\G5101	Stores the output data size of connection number 32.

Class1 I/O data start offset address

■Class1 Start offset address to the input data (Un\G5134 to Un\G5165)

In relation to the start address of 'Class1 communications input data area' (Un\G12000 to Un\G35999), stores the offset address of the input data for each connection.

- 0 to 32767: Offset address of each connection
- 65535: No offset address assignment

Address	Description
Un\G5134	Connection number 1 offset address
Un\G5135	Connection number 2 offset address
⋮	
Un\G5165	Connection number 32 offset address

Ex.

Indicates the offset address stored in 'Class1 Start offset address to the input data' (Un\G5134 to Un\G5165) for the input data stored in 'Class1 communications input data area' (Un\G12000 to Un\G35999).

Class1 communications input data area (Un\G12000 to Un\G35999)		Class1 Start offset address to the input data (Un\G5134 to Un\G5165)	
Address	Description	Address	Description
Un\G12000 to Un\G12749	Connection number 1 input data	Un\G5134	0
Un\G12750 to Un\G13499	Connection number 2 input data	Un\G5135	750
Un\G13500 to Un\G14249	Connection number 3 input data	Un\G5136	1500
Un\G14250 to Un\G14999	Connection number 4 input data	Un\G5137	2250

■Class1 Start offset address to the output data (Un\G5198 to Un\G5229)

In relation to the start address of 'Class1 communications output data area' (Un\G60000 to Un\G83999), stores the offset address of the output data for each connection.

- 0 to 32767: Offset address of each connection
- 65535: No offset address assignment

Address	Description
Un\G5198	Connection number 1 offset address
Un\G5199	Connection number 2 offset address
⋮	
Un\G5229	Connection number 3 offset address

Ex.

Indicates the offset address stored in 'Class1 Start offset address to the output data' (Un\G5198 to Un\G5229) for the output data stored in 'Class1 communications output data area' (Un\G60000 to Un\G83999).

Class1 communications output data area (Un\G60000 to Un\G83999)		Class1 Start offset address to the output data (Un\G5198 to Un\G5229)	
Address	Description	Address	Description
Un\G60000 to Un\G60749	Connection number 1 output data	Un\G5198	0
Un\G60750 to Un\G61499	Connection number 2 output data	Un\G5199	750
Un\G61500 to Un\G62249	Connection number 3 output data	Un\G5200	1500
Un\G62250 to Un\G62999	Connection number 4 output data	Un\G5201	2250

Application Trigger

■Application Trigger (Un\G5274 to Un\G5275, Un\G5278 to Un\G5279, Un\G5282 to Un\G5283)

This area requests and checks Application Triggers via UCMM communications.

Address	Name	bit	Connection number	Description
Un\G5274	Application Trigger Request (UCMM)	b0	Connection number 1	Requests Application Trigger for each connection number. • On: Request present • Off: Request not present
		b1	Connection number 2	
		⋮		
		b15	Connection number 16	
Un\G5275		b0 to b15	Connection number 17 to 32	
Un\G5278	Application Trigger Acceptance (UCMM)	b0	Connection number 1	Stores the acceptance status of Application Trigger for each connection number. • On: Accepted • Off: Not accepted
		b1	Connection number 2	
		⋮		
		b15	Connection number 16	
Un\G5279		b0 to b15	Connection number 17 to 32	
Un\G5282	Application Trigger Completion (UCMM)	b0	Connection number 1	Stores the completion status of Application Trigger for each connection number. • On: Completed • Off: Not completed
		b1	Connection number 2	
		⋮		
		b15	Connection number 16	
Un\G5283		b0 to b15	Connection number 17 to 32	

The timing chart at the start of UCMM communication (client function) is shown below.

-----> Performed by the FX5-ENET/IP

————> Performed by the program

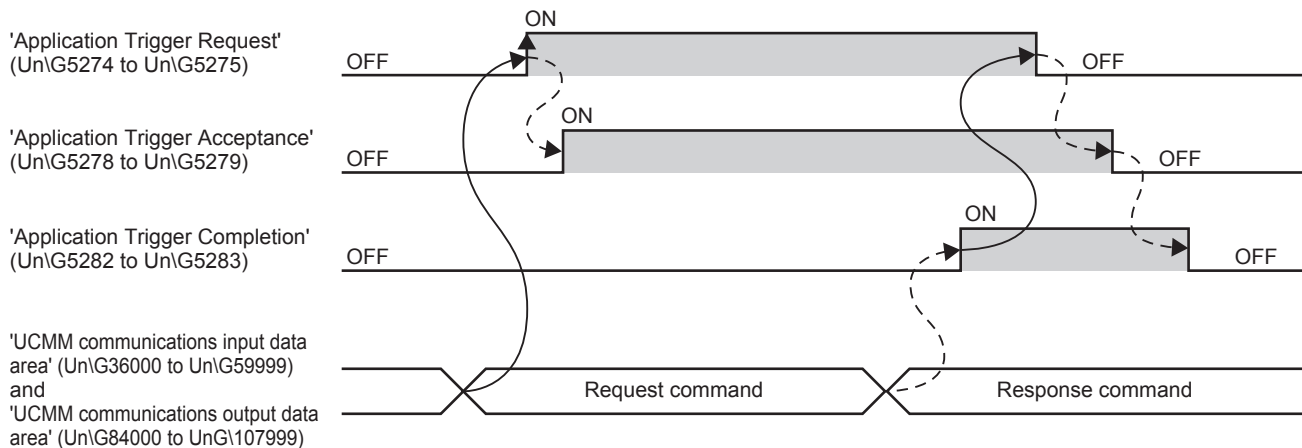

A

Precautions

- When the 'EtherNet/IP communication start request' (Un\G37.b0) is off, the Application Trigger does not operate.
- If the Application Trigger Request is turned off before the Application Trigger Completion and Application Trigger Receipt are turned on, the EtherNet/IP communication will not be executed.
- To execute the UCMM communication (turn on Application Trigger Request) again, make sure that Application Trigger Acceptance and Application Trigger Completion are off.

Class1 communication status

■Class1 communication status (Un\G6030 to Un\G6031, Un\G6034 to Un\G6035)

This area stores the communication status of Class1 communications for each connection number.

Address	Name	bit	Connection number	Description
Un\G6030	Data link status	b0	Connection number 1	Stores the data link status of connection numbers 1 to 32. It automatically turns on when communication recovers from an error. • On: Data link in operation (The input data from the target device was received at least once.) • Off: Not set, data link not in operation, error
		b1	Connection number 2	
		⋮		
		b15	Connection number 16	
Un\G6031		b0 to b15	Connection number 17 to 32	
Un\G6034	Error status	b0	Connection number 1	Stores the error status of connection numbers 1 to 32. It automatically turns off when communication recovers from an error. • On: Error • Off: Not set or data link in operation
		b1	Connection number 2	
		⋮		
		b15	Connection number 16	
Un\G6035		b0 to b15	Connection number 17 to 32	After turning on the 'EtherNet/IP communication start request' (Un\G37.b0), temporarily an error may occur until the connection is opened.

Connection behavior error status

■Connection behavior error status (Un\G6262 to Un\G6293)

This area stores the error code of the error that occurred during EtherNet/IP communications (Class1 communications) for each connection number. (0 is stored when communications are normal.) For details on the error codes, refer to the following.

☞ Page 124 List of Error Codes

After turning on the 'EtherNet/IP communication start request' (Un\G37.b0), temporarily an error code may be stored until the connection is opened.

Address	Description
Un\G6262	Class1 communications connection number 1 error code
Un\G6263	Class1 communications connection number 2 error code
⋮	
Un\G6293	Class1 communications connection number 32 error code

Area for simple CPU communication

■Area for simple CPU communication (Un\G6400 to Un\G8447)

Usable as a device that can be specified for the own station in the simple CPU communication. (Word device in units of 1 point)

Block assurance specification per connection

■Connection 1 to 32 input data update state (Un\G11434 to Un\G11465)

This area stores the update status of the input data when 'Block assurance state per connection' (Un\G5001) is set to "2: Data assurance is being performed."

- 0: No update available or data reading finished*1
- 1: Update available

*1 If a program is used to read the input data after the input data is updated, the buffer memory value changes from 1 to 0.

Address	Description
Un\G11434	Connection number 1 input data update state
Un\G11435	Connection number 2 input data update state
⋮	
Un\G11465	Connection number 32 input data update state

■Connection 1 to 32 output data update state (Un\G11498 to Un\G11529)

This area stores the update status of the output data when 'Block assurance state per connection' (Un\G5001) is set to "2: Data assurance is being performed."

- 0: No update available or data reading finished
- 1: Update available*1

*1 If a program is used to write the output data, the buffer memory value changes from 0 to 1.

Address	Description
Un\G11498	Connection number 1 output data update state
Un\G11499	Connection number 2 output data update state
⋮	
Un\G11529	Connection number 32 output data update state

Class1 communications input data area

■Class1 communications input data area (Un\G12000 to Un\G35999)

This area stores the data received by the FX5-ENET/IP from the EtherNet/IP device during Class1 communications.

Set the data to be received by the FX5-ENET/IP from the EtherNet/IP device in the EtherNet/IP Configuration Tool for FX5-ENET/IP. (☞ Page 87 [Connections] tab)

Address	Description
Un\G12000 to Un\G12749	Connection number 1 input data area
Un\G12750 to Un\G13499	Connection number 2 input data area
⋮	
Un\G35250 to Un\G35999	Connection number 32 input data area

UCMM communications input data area

■UCMM communications input data area (Un\G36000 to Un\G59999)

This area stores the data received by the FX5-ENET/IP from the EtherNet/IP device during UCMM communications.

Address	Description
Un\G36000 to Un\G36749	Connection number 1 input data area
Un\G36750 to Un\G37499	Connection number 2 input data area
⋮	
Un\G59250 to Un\G59999	Connection number 32 input data area

In the UCMM communication mode, the communication response command is received. The details of the received communication response command (connection No.1) are shown below. For the items received from the EtherNet/IP device, see the manual for the EtherNet/IP device.

Address	Name	Description
Un\G36000	Result storage area	Stores the processing result of request command. • 0: Completed successfully • Other than 0: Completed with an error (error code) ^{*1}
Un\G36001 to Un\G36002	Target IP Address	Stores the IP address of the EtherNet/IP device from which the response command was sent. • Un\G36001: 3rd octet, 4th octet • Un\G36002: 1st octet, 2nd octet (Example: If the IP address is 192.1.0.254 (C0H.01H.00H.FEH), the Un\G36001 is 00FEH and the Un\G36002 is C001H.)
Un\G36003	Service (service code)	Stores the service code of the EtherNet/IP device. ^{*1}
Un\G36004 to Un\G36005	System area	—
Un\G36006	Class (class ID)	Stores the class ID of the EtherNet/IP device. ^{*1}
Un\G36007	Instance (instance ID)	Stores the instance ID of the EtherNet/IP device. ^{*1}
Un\G36008	Attribute (attribute ID)	Stores the attribute ID of the EtherNet/IP device. ^{*1}
Un\G36009	Data length (data size)	Stores the data size of the EtherNet/IP device. (Unit: Bytes) ^{*1}
Un\G36010 to Un\G36031	System area	—
Un\G36032 to Un\G36738	Receive data	Stores the response data of the EtherNet/IP device. ^{*1}
Un\G36739 to Un\G36749	System area	—

*1 For the stored value, refer to the manuals of the EtherNet/IP device from which the command was sent.

Class1 communications output data area

■Class1 communications output data area (Un\G60000 to Un\G83999)

This area stores the data to send to the EtherNet/IP device from the FX5-ENET/IP during Class1 communications.

Set the data to send to the EtherNet/IP device from the FX5-ENET/IP in the EtherNet/IP Configuration Tool for FX5-ENET/IP.

( Page 87 [Connections] tab)

Address	Description
Un\G60000 to Un\G60749	Connection number 1 output data area
Un\G60750 to Un\G61499	Connection number 2 output data area
⋮	
Un\G83250 to Un\G83999	Connection number 32 output data area

UCMM communications output data area

■UCMM communications output data area

This area stores the data to send to the EtherNet/IP device from the FX5-ENET/IP during UCMM communications.

Address	Description
Un\G84000 to Un\G84749	Connection number 1 output data area
Un\G84750 to Un\G85499	Connection number 2 output data area
⋮	
Un\G107250 to Un\G107999	Connection number 32 output data area

In the UCMM communication mode, the communication response command is received. The details of the received communication response command (connection No.1) are shown below. For the items to send to the EtherNet/IP device, see the manual for the EtherNet/IP device.

Address	Name	Description
Un\G84000	Explicit message request type	Specifies the communication type. • 2000H: UCMM message communications
Un\G84001 to Un\G84002	Target IP Address	Specifies the IP address of the EtherNet/IP device to send the request command to. • Un\G84001: 3rd octet, 4th octet • Un\G84002: 1st octet, 2nd octet (Example: If the IP address is 192.1.0.254 (C0H.01H.00H.FEH), the Un\G84001 is 00FEH and the Un\G84002 is C001H.)
Un\G84003	Service (service code)	Specifies the service code of the EtherNet/IP device.*1
Un\G84004 to Un\G84005	System area	—
Un\G84006	Class (class ID)	Specifies the class ID of the EtherNet/IP device.*1
Un\G84007	Instance (instance ID)	Specifies the instance ID of the EtherNet/IP device.*1
Un\G84008	Attribute (attribute ID)	Specifies the attribute ID of the EtherNet/IP device.*1
Un\G84009	Data length (data size)	Specifies the data size of the EtherNet/IP device. (Unit: Bytes)*1
Un\G84010 to Un\G84031	System area	—
Un\G84032 to Un\G84738	Request data	Specifies the request data of the EtherNet/IP device.*1
Un\G84739 to Un\G84749	System area	—

*1 For the setting value, refer to the manuals of the send destination EtherNet/IP device.

Appendix 5 Details of Message Communication Support Command

This section describes the commands used during Class3 message communications and UCMM message communications.

Object list

The following table lists the objects that can be used with message communication support commands.

Object	Description	Reference
Identity	Holds information such as the identification information of the FX5-ENET/IP.	Page 168
Connection Manager	Used when establishing a connection with an FX5-ENET/IP.	Page 170
TCP/IP Interface	Holds the settings and status related to TCP/IP.	Page 171
Ethernet Link	Holds the settings and status related to Ethernet communication.	Page 173

Command explanations

Object items

The object items are shown below.

Item	Description
Class attribute	Data possessed by the class of an object.*1
Class service	Service performed by specifying a class.*1
Instance attribute	Data possessed by the instance of an object.*2
Instance service	Service performed by specifying an instance.*2

*1 A class possesses the basic information such as the revision and instance of the object.

*2 An instance possesses the information of each object such as its functions and data.

Class attribute/instance attribute items

The class attribute/instance attribute items are shown below.

■Access

This item indicates whether reading and writing using instance services are allowed.

Item	Description
Get	Reading is possible with services such as Get_Attribute_Single.
Set	Writing is possible with services such as Set_Attribute_Single.

■Data type

Indicates the class/instance data type. The data types available in FX5-ENET/IP (determined by the CIP specifications) are shown below.

Item	Description	Data size	Range
BOOL	Bit data	1 byte	0: Off (False) 1: On (True)
SINT	Signed 8-bit data	1 byte	-128 to +127
INT	Signed 16-bit data	2 byte	-32768 to +32767
DINT	Signed 32-bit data	4 byte	-2147483648 to +2147483647
USINT	Unsigned 8-bit data	1 byte	0 to 255
UINT	Unsigned 16-bit data	2 byte	0 to 65535
UDINT	Unsigned 32-bit data	4 byte	0 to 4294967295
ULINT	Unsigned 64-bit data	8 byte	0 to 18446744073709551615
REAL	Single-precision floating point real number	4 byte	E±1.17549435-38 to E±3.40282347+38
LREAL	Double-precision floating point real number	8 byte	E±2.2250738585072014-308 to E±1.7976931348623157+308
STRING	Character string data	Depends on the number of characters.	—
BYTE	Bit string (8 bits)	1 byte	—
WORD	Bit string (16 bits)	2 byte	—
DWORD	Bit string (32 bits)	4 byte	—
Padded EPATH	CIP path segment	4 byte	—

■Setting value (Set)/stored value (Get)

The content indicated by each value varies depending on the content of access.

Item	Description
"Get" is available	The setting value (Set)/stored value (Get) can be read from the FX5-ENET/IP.
"Set" is available	The setting value (Set)/stored value (Get) can be set on the FX5-ENET/IP.

Identity

Object name	Class ID
Identity	01H

Class attribute (instance ID: 00H)

Attribute ID	Access		Name	Data type	Description	Setting value (Set)/stored value (Get)
	Get	Set				
1	<input type="radio"/>	<input checked="" type="checkbox"/>	Revision	UINT	Object revision	0001H
2	<input type="radio"/>	<input checked="" type="checkbox"/>	Max Instance	UINT	Maximum instance number	0001H
3	<input type="radio"/>	<input checked="" type="checkbox"/>	Number of instances	UINT	Number of created instances	0001H

○: Available, ×: Not available

Class service

Service code	Service	Remarks
01H	Get_Attributes_All	00H is stored in the fourth to seventh bytes.
0EH	Get_Attribute_Single	—

Instance attribute (instance ID: 01H)

Attribute ID	Access		Name	Data type	Description	Setting value (Set)/stored value (Get)	
	Get	Set					
1	<input type="radio"/>	<input checked="" type="checkbox"/>	Vendor Id	UINT	Vendor ID number	00A1H	
2	<input type="radio"/>	<input checked="" type="checkbox"/>	Device Type	UINT	Device type	000CH	
3	<input type="radio"/>	<input checked="" type="checkbox"/>	Product Code	UINT	Product ID number	000AH	
4	<input type="radio"/>	<input checked="" type="checkbox"/>	Revision	Major Revision	USINT	Major revision	01H
				Minor Revision	USINT	Minor revision	01H
5	<input type="radio"/>	<input checked="" type="checkbox"/>	Status	WORD	Product status	 Page 169	
6	<input type="radio"/>	<input checked="" type="checkbox"/>	Serial Number	UDINT	Serial number	Varies between modules.	
7	<input type="radio"/>	<input checked="" type="checkbox"/>	Product Name	STRING	Product name	"FX5-ENET/IP"	

○: Available, ×: Not available

■Details of product status

Bit	Description	Value
0	Owned	The word "connection" described below refers to the "Exclusive Owner" connection. (The bit is not changed by an Input Only or Listen Only connection.) <ul style="list-style-type: none"> • 0: EtherNet/IP communications are not connected as the target device. • 1: At least one connection of EtherNet/IP communications is connected as the target device.
1	Reserved	Fixed to 0
2	Configured	Fixed to 1
3	Reserved	Fixed to 0
4 to 7	Extended Device Status	The word "connection" described below refers to the "Exclusive Owner" connection. (The bit is not changed by an Input Only or Listen Only connection.) <ul style="list-style-type: none"> • 0010 (2H): Error occurring on one or more connections • 0011 (3H): No connections established • 0101 (5H): Major Recoverable Fault or Major Unrecoverable Fault occurring • 0110 (6H): One or more connections performing normal communications in RUN mode • 0111 (7H): One or more connections all performing communications in IDLE mode
8	Minor Recoverable Fault	<ul style="list-style-type: none"> • 0: No error • 1: Minor error occurring
9	Minor Unrecoverable Fault	Fixed to 0
10	Major Recoverable Fault	<ul style="list-style-type: none"> • 0: No error • 1: Moderate error occurring
11	Major Unrecoverable Fault	<ul style="list-style-type: none"> • 0: No error • 1: Major error occurring
12 to 15	Extended Device Status 2	Fixed to 0

Instance service

Service code	Service
01H	Get_Attributes_All
0EH	Get_Attribute_Single

A

Connection Manager

Object name	Class ID
Connection Manager	06H

Class attribute (instance ID: 00H)

Attribute ID	Access		Name	Data type	Description	Setting value (Set)/stored value (Get)
	Get	Set				
1	<input type="radio"/>	<input checked="" type="checkbox"/>	Revision	UINT	Object revision	0001H
2	<input type="radio"/>	<input checked="" type="checkbox"/>	Max Instance	UINT	Maximum instance number	0001H
3	<input type="radio"/>	<input checked="" type="checkbox"/>	Number of instances	UINT	Number of created instances	0001H

○: Available, ×: Not available

Class service

Service code	Service	Remarks
01H	Get_Attributes_All	00H is stored in the fourth to seventh bytes.
0EH	Get_Attribute_Single	—

Instance attribute (instance ID: 01H)

Attribute ID	Access		Name	Data type	Description	Setting value (Set)/stored value (Get)
	Get	Set				
1	<input type="radio"/>	<input checked="" type="checkbox"/>	Open Requests	UINT	Number of received Forward_Open services	Value on the left
2	<input type="radio"/>	<input checked="" type="checkbox"/>	Open Format Rejects	UINT	Number of Forward_Open services rejected due to format incompatibility	Value on the left
3	<input type="radio"/>	<input checked="" type="checkbox"/>	Open Resource Rejects	UINT	Number of Forward_Open services rejected due to insufficient resources	Value on the left
4	<input type="radio"/>	<input checked="" type="checkbox"/>	Open Other Rejects	UINT	Number of Forward_Open services rejected due to reasons other than format incompatibility and insufficient resources	Value on the left
5	<input type="radio"/>	<input checked="" type="checkbox"/>	Close Requests	UINT	Number of received Forward_Close services	Value on the left
6	<input type="radio"/>	<input checked="" type="checkbox"/>	Close Format Requests	UINT	Number of Forward_Close services rejected due to format incompatibility	Value on the left
7	<input type="radio"/>	<input checked="" type="checkbox"/>	Close Other Requests	UINT	Number of Forward_Close services rejected due to reasons other than format incompatibility	Value on the left
8	<input type="radio"/>	<input checked="" type="checkbox"/>	Connection Timeouts	UINT	Total number of connection timeouts that occurred in connections controlled by the Connection Manager	Value on the left

○: Available, ×: Not available

Instance service

Service code	Service
01H	Get_Attributes_All
0EH	Get_Attribute_Single
4EH	Forward_Close
54H	Forward_Open
5BH	Large_Forward_Open

TCP/IP Interface

Object name	Class ID
TCP/IP Interface	F5H

Class attribute (instance ID: 00H)

Attribute ID	Access		Name	Data type	Description	Setting value (Set)/stored value (Get)
	Get	Set				
1	○	×	Revision	UINT	Object revision	0004H
2	○	×	Max Instance	UINT	Maximum instance number	0001H
3	○	×	Number of instances	UINT	Number of created instances	0001H

○: Available, ×: Not available

Class service

Service code	Service	Remarks
01H	Get_Attributes_All	—
0EH	Get_Attribute_Single	—

Instance attribute (instance ID: 01H)

Attribute ID	Access		Name	Data type	Description	Setting value (Set)/stored value (Get)	
	Get	Set					
1	○	×	Status	DWORD	Interface status	☞ Page 172	
2	○	×	Configuration Capability	DWORD	Interface capability flag	☞ Page 172	
3	○	×	Configuration Control	DWORD	Interface control flag	☞ Page 172	
4	○	×	Physical Link	Path size	UINT	Path size of physical link object	0002H
				Path	Padded EPATH	Logical segment that identifies the physical link object	<ul style="list-style-type: none"> • 0: 20H • 1: F6H • 2: 24H • 3: 01H
5	○	×	Interface Configuration	IP Address	UDINT	IP address of the device	Set values of parameters
				Network Mask	UDINT	Network mask of the device	
				Gateway Address	UDINT	Default gateway address	
				Name Server	UDINT	Primary name server	00000000H
				Name Server 2	UDINT	Secondary name server	00000000H
				Domain Name	STRING	Default domain name	" " (null character)
6	○	×	Host Name	STRING	Host name	" " (null character)	
13	○	○*1	Encapsulation Inactivity Timeout	UINT	Sets the time until the TCP connection or DTLS session is closed (unit: seconds)	<ul style="list-style-type: none"> • 1 to 3600 0 is invalid. (Default: 120) 	

○: Available, ×: Not available

*1 The setting data is saved to non-volatile memory.



■Details of interface status

Bit	Description	Value
0 to 3	Interface Configuration Status	Fixed to 2 (to set the IP address acquired from the parameter settings)
4	Mcast Pending	<ul style="list-style-type: none"> • 0: No changes to TTL Value and Mcast Config • 1: In the wait-for-restart state due to changes to TTL Value and Mcast Config
5 to 31	Reserved	Fixed to 0

■Details of interface capability flag

Bit	Description	Value
0	BOOTP Client	Fixed to 0 (because the BOOTP setting is not supported)
1	DNS Client	Fixed to 0 (because the name resolution setting with DNS is not supported)
2	DHCP Client	Fixed to 0 (because IP address setting with DHCP is not supported)
3	DHCP-DNS Update	Fixed to 0 (because the host name sending setting with DHCP requests is not supported)
4	Configuration Settable	Fixed to 0 (because Interface Configuration attribute setting is not supported)
5	Hardware Configurable	Fixed to 1 (available for IP addresses set with parameters)
6	Interface Configuration Change Requires Reset	Fixed to 0 (because Interface Configuration attribute setting is not supported)
7	AcCapable	Fixed to 0 (because the address duplication detection setting is not supported)
8 to 31	Reserved	Fixed to 0

■Details of interface control flag

Bit	Description	Value
0 to 3	Configuration Method	Fixed to 0 (to use IP addresses set with parameters)
4	DNS Enable	Fixed to 0 (because the name resolution setting with DNS is not supported)
5 to 31	Reserved	Fixed to 0

■IP multicast address setting value

Value	Description
0	The default assignment algorithm is used to create multicast addresses.
1	Multicast addresses are assigned according to the values specified for Num Mcast and Mcast Start Addr.
2	Reserved

Instance service

Service code	Service
01H	Get_Attributes_All
0EH	Get_Attribute_Single
10H	Set_Attribute_Single

Ethernet Link

Object name	Class ID
Ethernet Link	F6H

Class attribute (instance ID: 00H)

Attribute ID	Access		Name	Data type	Description	Setting value (Set)/stored value (Get)
	Get	Set				
1	<input type="radio"/>	<input checked="" type="checkbox"/>	Revision	UINT	Object revision	0004H
2	<input type="radio"/>	<input checked="" type="checkbox"/>	Max Instance	UINT	Maximum instance number	0001H
3	<input type="radio"/>	<input checked="" type="checkbox"/>	Number of instances	UINT	Number of created instances	0001H

○: Available, ×: Not available

Class service

Service code	Service	Remarks
01H	Get_Attributes_All	—
0EH	Get_Attribute_Single	—

Instance attribute (instance ID: 01H)

Attribute ID	Access		Name	Data type	Description	Setting value (Set)/stored value (Get)	
	Get	Set					
1	<input type="radio"/>	<input checked="" type="checkbox"/>	Interface Speed	UDINT	Communication speed of the current interface in use (unit: Mbps)	<ul style="list-style-type: none"> • 10 • 100 • 1000 	
2	<input type="radio"/>	<input checked="" type="checkbox"/>	Interface Flags	DWORD	Interface status flag	 Page 175	
3	<input type="radio"/>	<input checked="" type="checkbox"/>	Physical Address	USINT array [6]	MAC layer address	Varies between modules.	
4	<input type="radio"/>	<input checked="" type="checkbox"/>	Interface Counters	In Octets	UDINT	Number of octets received through the interface	00000000H
				In Ucast Packets	UDINT	Number of unicast packets received through the interface	00000000H
				In NUcast Packets	UDINT	Number of non-unicast packets received through the interface	00000000H
				In Discards	UDINT	Number of receive packets received through the interface but discarded	00000000H
				In Errors	UDINT	Number of receive packets including errors (number of packets not included in In Discards)	00000000H
				In Unknown Protos	UDINT	Number of receive packets including unknown protocols	00000000H
				Out Octets	UDINT	Number of octets sent through the interface	00000000H
				Out Ucast Protos	UDINT	Number of unicast packets sent through the interface	00000000H
				Out NUcast Protos	UDINT	Number of non-unicast packets sent through the interface	00000000H
				Out Discards	UDINT	Number of discarded transmission packets	00000000H
Out Errors	UDINT	Number of transmission packets including errors	00000000H				



Attribute ID	Access		Name	Data type	Description	Setting value (Set)/stored value (Get)			
	Get	Set							
5	○	×	Media Counters	Alignment Errors	UDINT	Number of receive frames with lengths that are not octet integers	00000000H		
				FCS Errors	UDINT	Number of receive frames that do not pass the FCS check	00000000H		
				Single Collisions	UDINT	Number of frames sent successfully with only one collision	00000000H		
				Multiple Collisions	UDINT	Number of frames sent successfully with two or more collisions	00000000H		
				SQE Test Errors	UDINT	Number of times SQE test error messages were created	00000000H		
				Deferred Transmissions	UDINT	Number of frames for which the first transmission test was delayed due to the medium being busy	00000000H		
				Late Collisions	UDINT	Number of collisions detected in packet transmission after 512 bit time or later in packet transmission	00000000H		
				Excessive Collisions	UDINT	Number of failed frames in transmission due to excessive collisions	00000000H		
				MAC Transmit Errors	UDINT	Number of frames that failed to be transmitted due to internal MAC sublayer transmission errors	00000000H		
				Carrier Sense Errors	UDINT	Number of times the carrier sense condition was lost or was not asserted during attempts to send frames	00000000H		
				Frame Too Long	UDINT	Number of receive frames that exceeded the maximum allowable frame size	00000000H		
MAC Receive Errors	UDINT	Number of frames that failed to be received through interface due to internal MAC sublayer receiving errors	00000000H						
6	○	○	Interface Control	Control Bits	WORD	Interface control bits	0001H		
				Forced Interface Speed	UINT	Forced interface operation speed	0000H		
7	○	×	Interface Type		USINT	Interface type	02H		
8	○	×	Interface State		USINT	Current interface status	01H		
9	○	○	Admin State		USINT	Current administration status	01H		
11	○	×	Interface Capability	Capability Bits		DWORD	Interface function other than Speed/Duplex	00000007H	
				Speed/Duplex Options	Speed/Duplex Array Count		USINT	Number of Speed/Duplex arrays	04H
					Speed/Duplex Array	Interface Speed	UINT	Speed to force the interface to operate at	10, 10, 100, 100
						Interface Duplex Mode	USINT	Duplex mode of the interface ^{*1}	0, 1, 0, 1

Attribute ID	Access		Name	Data type	Description	Setting value (Set)/stored value (Get)	
	Get	Set					
12	○	×	HC Interface Counters	HCInOctets	ULINT	Number of octets received through the interface	0000000000000000H
				HCInUcastPkts	ULINT	Number of unicast packets received through the interface	0000000000000000H
				HCInMulticastPkts	ULINT	Number of multicast packets received through the interface	0000000000000000H
				HCInBroadcastPkts	ULINT	Number of broadcast packets received through the interface	0000000000000000H
				HCOutOctets	ULINT	Number of octets sent through the interface	0000000000000000H
				HCOutUcastPkts	ULINT	Number of packets sent through the interface	0000000000000000H
				HCOutMulticastPkts	ULINT	Number of multicast packets sent through the interface	0000000000000000H
				HCOutBroadcastPkts	ULINT	Number of broadcast packets sent through the interface	0000000000000000H
13	○	×	HC Media Counters	HCStatsAlignmentErrors	ULINT	64-bit version of Alignment Errors	0000000000000000H
				HCStatsFCSErrors	ULINT	64-bit version of FCS Errors	0000000000000000H
				HCStatsInternalMacTransmitErrors	ULINT	64-bit version of MAC Transmit Errors	0000000000000000H
				HCStatsFrameTooLongs	ULINT	64-bit version of Frame Too Long	0000000000000000H
				HCStatsInternalMacReceiveErrors	ULINT	64-bit version of MAC Receive Errors	0000000000000000H
				HCStatsSymbolErrors	ULINT	Number of illegal data symbols in the media when a valid carrier exists	0000000000000000H

○: Available, ×: Not available

*1 Arrays are displayed in combination with Interface Speed. This indicates the speed and Duplex mode supported by the module.

■Details of status flag

Bit	Description	Value
0	Link-up status	<ul style="list-style-type: none"> 0: Link-down 1: Link-up
1	Connection status (full-duplex/half-duplex)	<ul style="list-style-type: none"> 0: Half-duplex 1: Full-duplex
2 to 4	Auto-negotiation status	<ul style="list-style-type: none"> 0: Auto-negotiation being executed 1: Auto-negotiation failed and operation in progress with the default communication speed and method 2: Communication method detection failed, but communication speed detection succeeded 3: Auto-negotiation completed successfully 4: Auto-negotiation unexecuted
5	Necessity of restart after manual settings	Fixed to 0 (because manual settings are not supported)
6	Local Hardware Fault detection status	Fixed to 0 (because Local Hardware Faults are not detected)
7 to 31	Fixed value	0

Instance service

Service code	Service
01H	Get_Attributes_All
0EH	Get_Attribute_Single
4CH	Get_and_Clear

Appendix 6 Processing Time

The data link processing time is explained below.

RPI (Requested Packet Interval)

FX5-ENET/IP transmits and receives data according to the RPI interval defined by the parameter setting set by EtherNet/IP Configuration Tool for FX5-ENET/IP. The fastest value of RPI is calculated by the following formula based on the PPS of FX5-ENET/IP and the number of connections.

$$\text{RPI fastest value} = \frac{2 \times \text{Number of connection}}{\text{PPS}} \text{ (s)}$$

Transmission delay time

The following describes the formulas used to calculate the transmission delay time of EtherNet/IP communications.

Note that the processing time may be prolonged depending on the load ratio of the network (degree of line congestion), the processing performance of controllers, and the system configuration.

Class1 communication

■Send delay time

The concept of transmission delay time in Class1 communication mode is shown below.

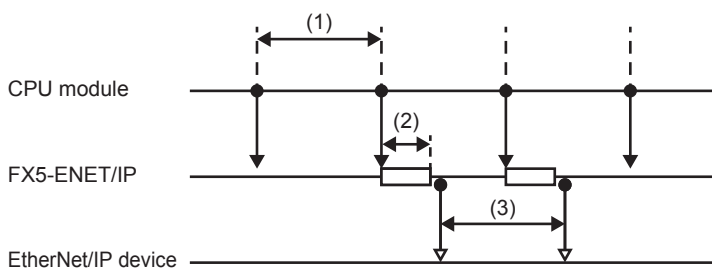

No.	Item name	Description
(1)	Sequence scan	Time required from setting the send data in a program to refreshing the buffer memory on the FX5-ENET/IP.
(2)	Send delay time	Time required for transferring send data from the buffer memory on the FX5-ENET/IP to the send buffer. (Approx. 1 ms)
(3)	RPI	RPI setting value (transmission interval time)

The transmitted data transmission delay time in Class1 communication mode is calculated by the following formula.

$$\text{Maximum value} = (1) + (2) + (3) \text{ (ms)}$$

■Receive delay time

The concept of receive delay time in Class1 communication mode is shown below

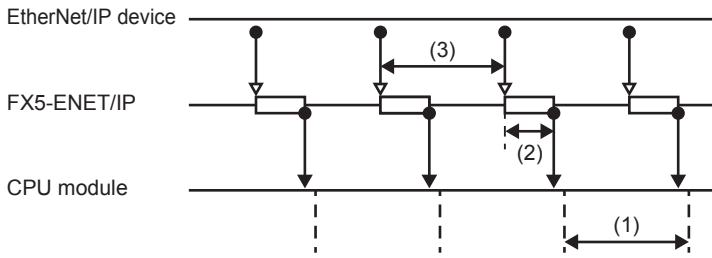

No.	Item name	Description
(1)	Sequence scan	Time required for refreshing the receive data from the buffer memory on the FX5-ENET/IP to a program.
(2)	Receive delay time	Time required for transferring receive data from the receive buffer to the buffer memory on the FX5-ENET/IP. (Approx. 1 ms)
(3)	RPI	RPI setting value (transmission interval time)

The received data transmission delay time in Class1 communication mode is calculated by the following formula.

$$\text{Maximum value} = (1) + (2) + (3) \text{ (ms)}$$

Appendix 7 Software Licenses and Copyrights

This section describes the licenses and copyrights of software used in this product.

MD5 Message-Digest Algorithm

This product includes code that was developed by RSA Data Security, Inc.

Copyright (C) 1991-2, RSA Data Security, Inc.

License to copy and use this software is granted provided that it is identified as the "RSA Data Security, Inc. MD5 Message-Digest Algorithm" in all material mentioning or referencing this software or this function.

License is also granted to make and use derivative works provided that such works are identified as "derived from the RSA Data Security, Inc. MD5 Message-Digest Algorithm" in all material mentioning or referencing the derived work.

RSA Data Security, Inc. makes no representations concerning either the merchantability of this software or the suitability of this software for any particular purpose. It is provided "as is" without express or implied warranty of any kind.

These notices must be retained in any copies of any part of this documentation and/or software.

Appendix 8 Added and Changed Functions

This appendix shows the functions added to FX5-ENET/IP and engineering tool or changed functions, the firmware versions of the appropriate FX5-ENET/IP and CPU module and the software version of the engineering tool.

The firmware version of the FX5-ENET/IP can be found in the buffer memory. (☞ Page 148 Firmware version)

The firmware version of the CPU module can be confirmed by module diagnosis (CPU diagnosis). For the module diagnosis (CPU diagnosis), refer to the following manual.

📖 MELSEC iQ-F FX5S/FX5UJ/FX5U/FX5UC User's Manual (Hardware)

For the software version, refer to 📖 GX Works3 Operating Manual.

FX5UJ CPU module

Add/Change Function	Applicable versions			Reference
	Firmware version of the CPU module	Firmware version of the FX5-ENET/IP	Software version of the engineering tool	
MELSOFT connection	"1.010" and above	"1.100" and above	"1.075D" and above	MELSEC iQ-F FX5 User's Manual (Ethernet Communication)
SLMP communication types	"1.010" and above	"1.100" and above	"1.075D" and above	MELSEC iQ-F FX5 User's Manual (Ethernet Communication)
Simple CPU communication function	"1.010" and above	"1.100" and above	"1.075D" and above	MELSEC iQ-F FX5 User's Manual (Ethernet Communication)
BACnet function	"1.010" and above	"1.100" and above	"1.075D" and above	MELSEC iQ-F FX5 User's Manual (BACnet)

FX5U/FX5UC CPU module

Add/Change Function	Applicable versions			Reference
	Firmware version of the CPU module	Firmware version of the FX5-ENET/IP	Software version of the engineering tool	
Firmware update function	"1.240" and above	"1.003" and above	"1.075D" and above	MELSEC iQ-F FX5 User's Manual (Application)
MELSOFT connection	"1.240" and above	"1.100" and above	"1.075D" and above	MELSEC iQ-F FX5 User's Manual (Ethernet Communication)
SLMP communication types	"1.240" and above	"1.100" and above	"1.075D" and above	MELSEC iQ-F FX5 User's Manual (Ethernet Communication)
Simple CPU communication function	"1.240" and above	"1.100" and above	"1.075D" and above	MELSEC iQ-F FX5 User's Manual (Ethernet Communication)
BACnet function	"1.240" and above	"1.100" and above	"1.075D" and above	MELSEC iQ-F FX5 User's Manual (BACnet)

INDEX

A

Adapter	41
Application Trigger	161
Assurance of input/output data	31

B

BACnet function	22
Block assurance specification per connection	158,163
Block assurance state per connection	158

C

Class1 communication status	162
Class1 communications input data area	163
Class1 communications output data area	164
Class1 I/O data size	159
Class1 I/O data start offset address	160
Class1 instance communications	22,25
Class3 message communications	22,32
Client function	37
Communication mode	48
Communication status setting function at the occurrence of a CPU stop error	22
Communication status setting function when a CPU stop error occurs	40
Connected module search function	22
Connection behavior error status	162

D

Direct connection with MELSOFT	22
--	----

E

EDS Management wizard	100
Ethernet diagnostics	22,113
EtherNet/IP communication in process	148
EtherNet/IP communication start request	149
EtherNet/IP data link continuation specification	159
Event history function	22,117
Exclusive Owner	25

F

Firmware update function	22
------------------------------------	----

H

Hardware test	22,121
-------------------------	--------

I

Input Only	26
IP address change function	22
IP address setting	49
IP filter function	22

L

Listen Only	26
-----------------------	----

M

MELSOFT connection	22
MELSOFT diagnosis function	22
Module diagnostics	111
Module error clear request	149
Module ready	148

O

Online Action	71
-------------------------	----

S

Scanner	41
Server function	33,38
Simple CPU communication function	22
SLMP communication function	22
Socket communication function	22

U

UCMM communications input data area	164
UCMM communications output data area	165
UCMM message communications	22,36

MEMO

REVISIONS

Revision date	Revision	Description
October 2018	A	First Edition
October 2019	B	■Added models FX5UJ CPU module ■Added or modified parts RELEVANT MANUALS, TERMS, Section 2.3, Chapter 3, Section 4.2, Section 7.2, Section 7.3, Section 7.4, Appendix 4, TRADEMARKS
August 2020	C	■Added or modified parts SAFETY PRECAUTIONS, WARRANTY
April 2021	D	■Added functions Firmware update function, MELSOFT connection, SLMP communication function, simple CPU communication function and BACnet function ■Added/corrected parts RELEVANT MANUALS, TERMS, Chapter 1, Section 2.3, Chapter 3, Section 4.1, 7.3, 7.4, 8.1, 10.6, 10.7, Appendix 2, 4, 7, TRADEMARKS
June 2021	E	■Added or modified part Section 5.3
December 2021	F	■Added or modified parts RELEVANT MANUALS, TERMS, GENERIC TERMS AND ABBREVIATIONS, Section 7.5, Appendix 7, 8
April 2022	G	■Added or modified parts RELEVANT MANUALS, GENERIC TERMS AND ABBREVIATIONS, Section 2.1, Chapter 3, Appendix 2, 8

Japanese manual number: SH-082025-H

This manual confers no industrial property rights or any rights of any other kind, nor does it confer any patent licenses. Mitsubishi Electric Corporation cannot be held responsible for any problems involving industrial property rights which may occur as a result of using the contents noted in this manual.

© 2018 MITSUBISHI ELECTRIC CORPORATION

WARRANTY

Please confirm the following product warranty details before using this product.

1. Gratis Warranty Term and Gratis Warranty Range

If any faults or defects (hereinafter "Failure") found to be the responsibility of Mitsubishi occurs during use of the product within the gratis warranty term, the product shall be repaired at no cost via the sales representative or Mitsubishi Service Company. However, if repairs are required onsite at domestic or overseas location, expenses to send an engineer will be solely at the customer's discretion. Mitsubishi shall not be held responsible for any re-commissioning, maintenance, or testing on-site that involves replacement of the failed module.

[Gratis Warranty Term]

The gratis warranty term of the product shall be for one year after the date of purchase or delivery to a designated place. Note that after manufacture and shipment from Mitsubishi, the maximum distribution period shall be six (6) months, and the longest gratis warranty term after manufacturing shall be eighteen (18) months. The gratis warranty term of repair parts shall not exceed the gratis warranty term before repairs.

[Gratis Warranty Range]

- (1) The range shall be limited to normal use within the usage state, usage methods and usage environment, etc., which follow the conditions and precautions, etc., given in the instruction manual, user's manual and caution labels on the product.
- (2) Even within the gratis warranty term, repairs shall be charged for in the following cases.
 1. Failure occurring from inappropriate storage or handling, carelessness or negligence by the user. Failure caused by the user's hardware or software design.
 2. Failure caused by unapproved modifications, etc., to the product by the user.
 3. When the Mitsubishi product is assembled into a user's device, Failure that could have been avoided if functions or structures, judged as necessary in the legal safety measures the user's device is subject to or as necessary by industry standards, had been provided.
 4. Failure that could have been avoided if consumable parts (battery, backlight, fuse, etc.) designated in the instruction manual had been correctly serviced or replaced.
 5. Relay failure or output contact failure caused by usage beyond the specified life of contact (cycles).
 6. Failure caused by external irresistible forces such as fires or abnormal voltages, and failure caused by force majeure such as earthquakes, lightning, wind and water damage.
 7. Failure caused by reasons unpredictable by scientific technology standards at time of shipment from Mitsubishi.
 8. Any other failure found not to be the responsibility of Mitsubishi or that admitted not to be so by the user.

2. Onerous repair term after discontinuation of production

- (1) Mitsubishi shall accept onerous product repairs for seven (7) years after production of the product is discontinued.
Discontinuation of production shall be notified with Mitsubishi Technical Bulletins, etc.
- (2) Product supply (including repair parts) is not available after production is discontinued.

3. Overseas service

Overseas, repairs shall be accepted by Mitsubishi's local overseas FA Center. Note that the repair conditions at each FA Center may differ.

4. Exclusion of loss in opportunity and secondary loss from warranty liability

Regardless of the gratis warranty term, Mitsubishi shall not be liable for compensation to:

- (1) Damages caused by any cause found not to be the responsibility of Mitsubishi.
- (2) Loss in opportunity, lost profits incurred to the user by Failures of Mitsubishi products.
- (3) Special damages and secondary damages whether foreseeable or not, compensation for accidents, and compensation for damages to products other than Mitsubishi products.
- (4) Replacement by the user, maintenance of on-site equipment, start-up test run and other tasks.

5. Changes in product specifications

The specifications given in the catalogs, manuals or technical documents are subject to change without prior notice.

6. Product application

- (1) In using the Mitsubishi MELSEC programmable controller, the usage conditions shall be that the application will not lead to a major accident even if any problem or fault should occur in the programmable controller device, and that backup and fail-safe functions are systematically provided outside of the device for any problem or fault.
- (2) The Mitsubishi programmable controller has been designed and manufactured for applications in general industries, etc. Thus, applications in which the public could be affected such as in nuclear power plants and other power plants operated by respective power companies, and applications in which a special quality assurance system is required, such as for railway companies or public service purposes shall be excluded from the programmable controller applications.
In addition, applications in which human life or property that could be greatly affected, such as in aircraft, medical applications, incineration and fuel devices, manned transportation, equipment for recreation and amusement, and safety devices, shall also be excluded from the programmable controller range of applications. However, in certain cases, some applications may be possible, providing the user consults their local Mitsubishi representative outlining the special requirements of the project, and providing that all parties concerned agree to the special circumstances, solely at the user's discretion.
- (3) Mitsubishi shall have no responsibility or liability for any problems involving programmable controller trouble and system trouble caused by DoS attacks, unauthorized access, computer viruses, and other cyberattacks.

TRADEMARKS

Anywire and AnyWireASLINK are either registered trademarks or trademarks of Anywire Corporation.

The company names, system names and product names mentioned in this manual are either registered trademarks or trademarks of their respective companies.

In some cases, trademark symbols such as [™] or [®] are not specified in this manual.

Manual number: SH(NA)-082027ENG-G

MODEL: FX5-U-ENETIP-E

MODEL CODE: 09R737

MITSUBISHI ELECTRIC CORPORATION

HEAD OFFICE : TOKYO BUILDING, 2-7-3 MARUNOUCHI, CHIYODA-KU, TOKYO 100-8310, JAPAN
NAGOYA WORKS : 1-14 , YADA-MINAMI 5-CHOME , HIGASHI-KU, NAGOYA , JAPAN

When exported from Japan, this manual does not require application to the
Ministry of Economy, Trade and Industry for service transaction permission.

Specifications subject to change without notice.