

SYSMAC CP Series

CP1E-E□□SD□-□

CP1E-N□□S□D□-□

CP1E-E□□D□-□

CP1E-N□□D□-□

CP1E-NA□□D□-□

CP1E CPU Unit Hardware

USER'S MANUAL

OMRON

NOTE

All rights reserved. No part of this publication may be reproduced, stored in a retrieval system, or transmitted, in any form, or by any means, mechanical, electronic, photocopying, recording, or otherwise, without the prior written permission of OMRON.

No patent liability is assumed with respect to the use of the information contained herein. Moreover, because OMRON is constantly striving to improve its high-quality products, the information contained in this manual is subject to change without notice. Every precaution has been taken in the preparation of this manual. Nevertheless, OMRON assumes no responsibility for errors or omissions. Neither is any liability assumed for damages resulting from the use of the information contained in this publication.

Trademarks

- Microsoft, Windows are either registered trademarks or trademarks of Microsoft Corporation in the United States and other countries.

Other company names and product names in this document are the trademarks or registered trademarks of their respective companies.

Copyrights

Microsoft product screen shots reprinted with permission from Microsoft Corporation.

SYSMAC CP Series

CP1E-E□□SD□-□

CP1E-N□□S□D□-□

CP1E-E□□D□-□

CP1E-N□□D□-□

CP1E-NA□□D□-□

CP1E CPU Unit Hardware

User's Manual

Revised July 2017

Introduction

Thank you for purchasing a SYSMAC CP-series CP1E Programmable Controller.

This manual contains information required to use the CP1E. Read this manual completely and be sure you understand the contents before attempting to use the CP1E.

Intended Audience

This manual is intended for the following personnel, who must also have knowledge of electrical systems (an electrical engineer or the equivalent).

- Personnel in charge of installing FA systems
- Personnel in charge of designing FA systems
- Personnel in charge of managing FA systems and facilities

Applicable Products

● CP-series CP1E CPU Units

- Basic Models CP1E-E□□(S)D□-□
A basic model of CPU Unit that support basic control applications using instructions such as basic, movement, arithmetic, and comparison instructions.
- Application Models CP1E-N/NA□□(S□)D□-□
An application model of CPU Unit that supports connections to Programmable Terminals, inverters, and servo drives.

The CP Series is centered around the CP1H, CP1L, and CP1E CPU Units and is designed with the same basic architecture as the CS and CJ Series.

Always use CP-series Expansion Units and CP-series Expansion I/O Units when expanding I/O capacity. I/O words are allocated in the same way as for the CPM1A/CPM2A PLCs, i.e., using fixed areas for inputs and outputs.

CP1E CPU Unit Manuals

Information on the CP1E CPU Units is provided in the following manuals.
Refer to the appropriate manual for the information that is required.

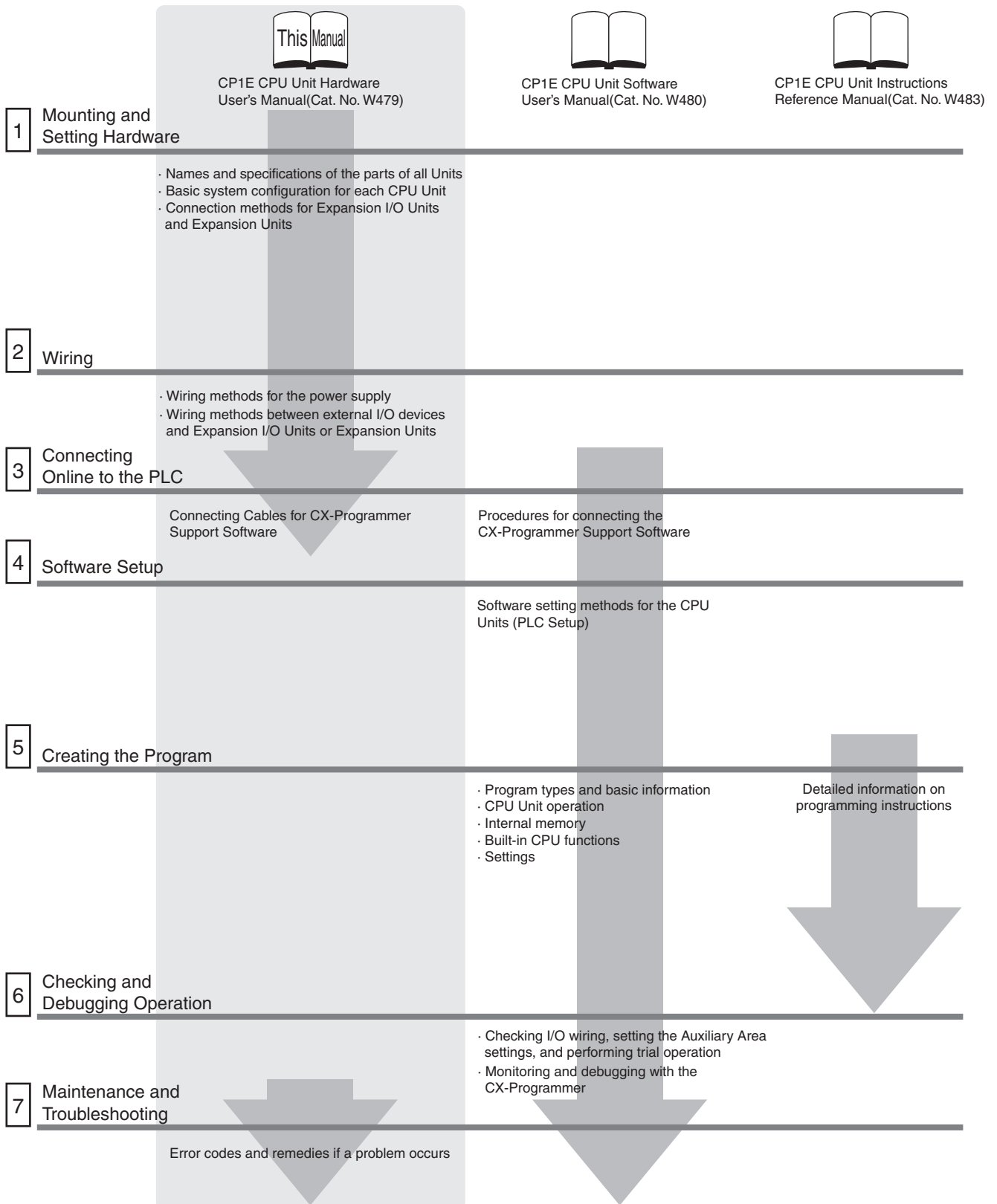

Manual Configuration

The CP1E CPU manuals are organized in the sections listed in the following tables. Refer to the appropriate section in the manuals as required.

CP1E CPU Unit Hardware User's Manual (Cat. No. W479) (This Manual)

Section	Contents
Section 1 Overview and Specifications	This section gives an overview of the CP1E, describes its features, and provides its specifications.
Section 2 Basic System Configuration and Devices	This section describes the basic system configuration and unit models of the CP1E.
Section 3 Part Names and Functions	This section describes the part names and functions of the CPU Unit, Expansion I/O Units, and Expansion Units in a CP1E PLC .
Section 4 Programming Device	This section describes the features of the CX-Programmer used for programming and debugging PLCs, as well as how to connect the PLC with the Programming Device by USB.
Section 5 Installation and Wiring	This section describes how to install and wire CP1E Units.
Section 6 Troubleshooting	This section describes how to troubleshoot problems that may occur with a CP1E PLC, including the error indications provided by the CP1E Units.
Section 7 Maintenance and Inspection	This section describes periodic inspections, the service life of the Battery, and how to replace the Battery.
Section 8 Using Expansion Units and Expansion I/O Units	This section describes application methods for Expansion Units.
Appendices	The appendices provide information on dimensions, wiring diagrams, and wiring serial communications for the CP1E.

CP1E CPU Unit Software User's Manual (Cat. No. W480)

Section	Contents
Section 1 Overview	This section gives an overview of the CP1E, describes its application procedures.
Section 2 CPU Unit Memory	This section describes the types of internal memory in a CP1E CPU Unit and the data that is stored.
Section 3 CPU Unit Operation	This section describes the operation of a CP1E CPU Unit.
Section 4 Programming Concepts	This section provides basic information on designing ladder programs for a CP1E CPU Unit.
Section 5 I/O Memory	This section describes the types of I/O memory areas in a CP1E CPU Unit and the details.
Section 6 I/O Allocation	This section describes I/O allocation used to exchange data between the CP1E CPU Unit and other units.
Section 7 PLC Setup	This section describes the PLC Setup, which are used to perform basic settings for a CP1E CPU Unit.
Section 8 Overview and Allocation of Built-in Functions	This section lists the built-in functions and describes the overall application flow and the allocation of the functions.
Section 9 Quick-response Inputs	This section describes the quick-response inputs that can be used to read signals that are shorter than the cycle time.
Section 10 Interrupts	This section describes the interrupts that can be used with CP1E PLCs, including input interrupts and scheduled interrupts.

Section	Contents
Section 11 High-speed Counters	This section describes the high-speed counter inputs, high-speed counter interrupts, and the frequency measurement function.
Section 12 Pulse Outputs	This section describes positioning functions such as trapezoidal control, jogging, and origin searches.
Section 13 PWM Outputs	This section describes the variable-duty-factor pulse (PWM) outputs.
Section 14 Serial Communications	This section describes communications with Programmable Terminals (PTs) without using communications programming, no-protocol communications with general components, and connections with a Modbus-RTU Easy Master, Serial PLC Link, and host computer.
Section 15 Analog I/O Function	This section describes the built-in analog function for NA-type CPU Units.
Section 16 Built-in Functions	This section describes PID temperature control, clock functions, DM backup functions, security functions.
Section 17 Ethernet Option Board	This section gives an overview of the Ethernet Option Board, describes its setting methods, I/O memory allocations, troubleshooting, how to connect the CX-Programmer, and how to install an Ethernet network.
Section 18 Analog Option Board	This section describes an overview of the Analog Option Board, describes its installation and setting methods, memory allocations, start-up operation, refresh time, troubleshooting and how to use the Analog Option Board.
Section 19 Operating the Programming Device	This section describes basic functions of the CX-Programmer, such as using the CX-Programmer to write ladder programs to control the CP1E CPU Unit, to transfer the programs to the CP1E CPU Unit, and to debug the programs.
Appendices	The appendices provide lists of programming instructions, the Auxiliary Area, cycle time response performance, PLC performance at power interruption.

CP1E CPU Unit Instructions Reference Manual (Cat. No. W483)

Section	Contents
Section 1 Summary of Instructions	This section provides a summary of instructions used with a CP1E CPU Unit.
Section 2 Instruction	This section describes the functions, operands and sample programs of the instructions that are supported by a CP1E CPU Unit.
Section 3 Instruction Execution Times and Number of Steps	This section provides the execution times for all instructions used with a CP1E CPU Unit.
Section 4 Monitoring and Computing the Cycle Time	This section describes how to monitor and calculate the cycle time of a CP1E CPU Unit that can be used in the programs.
Appendices	The appendices provide a list of instructions by Mnemonic and ASCII code table for the CP1E CPU Unit.

Manual Structure

Page Structure and Icons

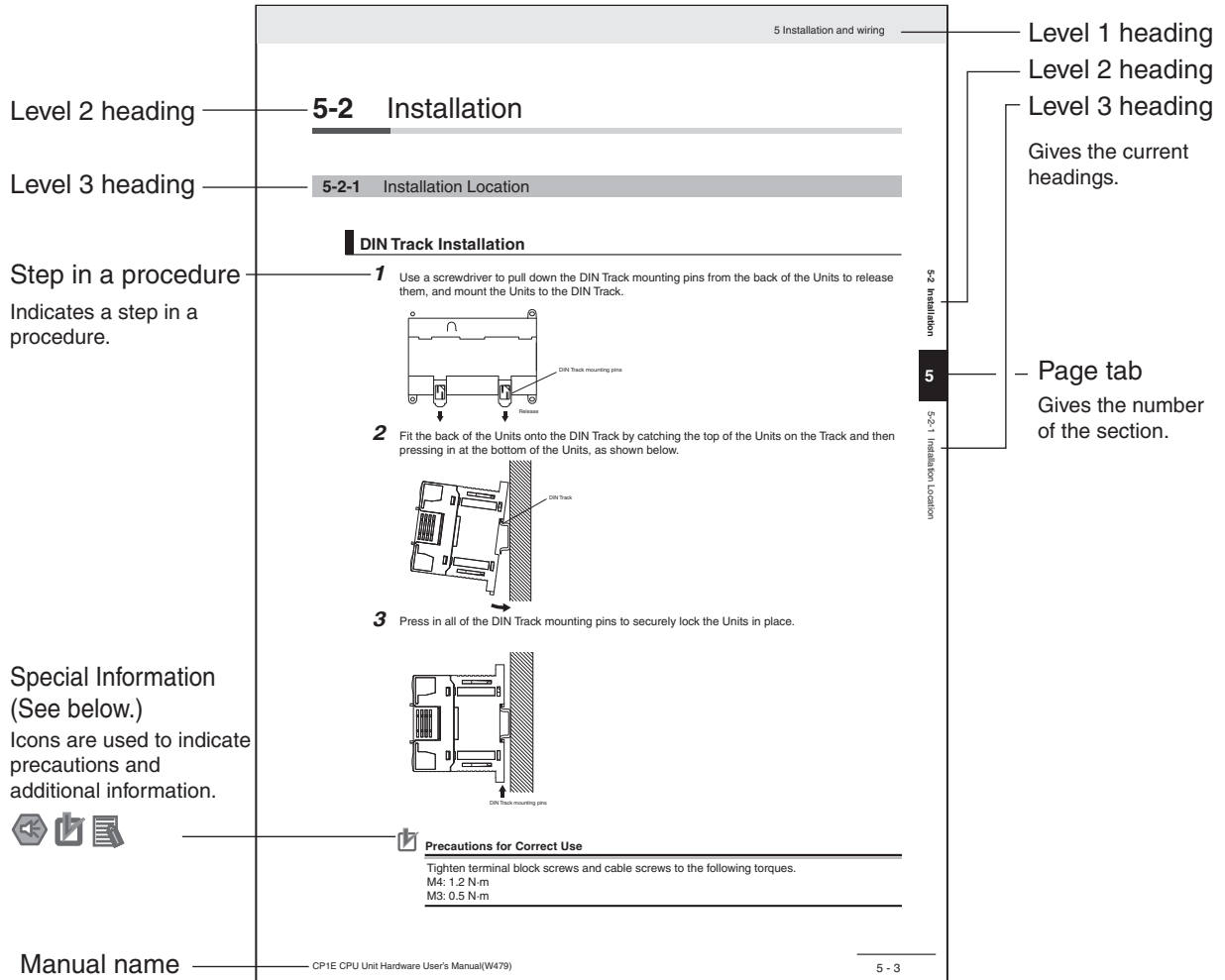

The following page structure and icons are used in this manual.



This illustration is provided only as a sample and may not literally appear in this manual.

Special Information

Special information in this manual is classified as follows:

- 
Precautions for Safe Use
 Precautions on what to do and what not to do to ensure using the product safely.
- 
Precautions for Correct Use
 Precautions on what to do and what not to do to ensure proper operation and performance.
- 
Additional Information
 Additional information to increase understanding or make operation easier.

Terminology and Notation

Term	Description
E-type CPU Unit	<p>A basic model of CPU Unit that support basic control applications using instructions such as basic, movement, arithmetic, and comparison instructions.</p> <p>Basic models of CPU Units are called “E□□(S)-type CPU Units” in this manual.</p> <p>The models of E□□(S)-type CPU Units are shown below.</p> <p>CP1E-E□□D□-□</p> <p>CP1E-E□□SD□-□</p>
N-type CPU Unit	<p>An application model of CPU Unit that supports connections to Programmable Terminals, inverters, and servo drives.</p> <p>Application models of CPU Units are called “N□□(S)-type CPU Units” in this manual.</p> <p>The models of N□□(S)-type CPU Units are shown below.</p> <p>CP1E-N□□D□-□</p> <p>CP1E-N□□SD□-□</p> <p>CP1E-N□□S1D□-□</p>
NA-Type CPU Unit	<p>An application model of CPU Unit that supports built-in analog and connections to Programmable Terminals, inverters, and servo drives.</p> <p>Application models of CPU Units with built-in analog are called “NA-type CPU Units” in this manual.</p>
CX-Programmer	<p>A programming device that applies for programming and debugging PLCs.</p> <p>The CX-Programmer includes the Micro PLC Edition CX-Programmer (CX-One Lite), the CX-Programmer (CX-One) and the CX-Programmer for CP1E.</p> <p>This manual describes the unique applications and functions of the Micro PLC Edition CX-Programmer version 9.03 or higher/CX-Programmer for CP1E.</p> <p>“CX-Programmer” refers to the Micro PLC Edition CX-Programmer version 9.03 or higher/CX-Programmer for CP1E in this manual.</p> <p>Note E20/30/40(S) and N20/30/40(S□) CPU Units are supported by CX-Programmer version 8.2 or higher. E10/14(S), N14/60(S□) and NA20 CPU Units are supported by CX-Programmer version 9.03 or higher. E60S CPU Units are supported by CX-Programmer version 9.42 or higher.</p>

Sections in this Manual

1	Overview and Specifications	1
2	Basic System Configuration and Devices	2
3	Part Names and Functions	3
4	Programming Device	4
5	Installation and Wiring	5
6	Troubleshooting	6
7	Maintenance and Inspection	7
8	Using Expansion Units and Expansion I/O Units	8
A	Appendices	A

CONTENTS

Introduction	1
CP1E CPU Unit Manuals	2
Manual Structure	5
Terms and Conditions Agreement.....	12
Safety Precautions	14
Precautions for Safe Use.....	19
Operating Environment Precautions.....	22
Regulations and Standards.....	23
Related Manuals	24

Section 1 Overview and Specifications

1-1 CP1E Overview	1-2
1-1-1 Overview of Features.....	1-2
1-1-2 Features.....	1-3
1-2 Basic Operating Procedure	1-8
1-3 Specifications	1-9
1-3-1 General Specifications	1-9
1-3-2 Characteristics	1-10
1-3-3 Functional Specifications	1-12
1-4 Difference between E/N/NA□□-type and E/N□□S(1)-type	1-14

Section 2 Basic System Configuration and Devices

2-1 Basic System Configuration.....	2-2
2-1-1 Basic System Configuration Using an E□□(S)-type CPU Unit	2-2
2-1-2 Basic System Configuration Using an N/NA□□(S□)-type CPU Unit.....	2-3
2-2 CPU Units	2-4
2-2-1 CPU Unit Models	2-4
2-2-2 Optional Products.....	2-9
2-2-3 Unit Versions of CPU Units.....	2-11
2-3 Expansion I/O Unit or Expansion Unit.....	2-13
2-3-1 Expandable CPU Units	2-13
2-3-2 Connection Methods	2-13
2-3-3 Maximum Number of I/O Points for an Expansion I/O Unit or Expansion Unit	2-13
2-3-4 Expansion I/O Units and Expansion Units	2-14
2-3-5 Restrictions on System Configuration	2-16
2-4 Unit Current Consumption and External Power Supply Capacity	2-18
2-4-1 External Power Supply Capacity When Expansion I/O Units or Expansion Units are Connected.....	2-18
2-4-2 Current Consumption.....	2-19

Section 3 Part Names and Functions

3-1 CPU Units	3-2
3-1-1 E10/14/20(S) or N14/20 CPU Units	3-2
3-1-2 E30/40/60(S), N30/40/60(S□) or NA20 CPU Units	3-7
3-1-3 Common I/O Specifications.....	3-13
3-1-4 Optional Serial Communications Port for N/NA□□(S□)-type CPU Units	3-19
3-1-5 Analog Option Board for N/NA□□-type CPU Units.....	3-24
3-2 Expansion I/O Units	3-28
3-2-1 Expansion Input Unit.....	3-28
3-2-2 Expansion Output Units	3-29
3-2-3 Expansion I/O Units	3-31
3-2-4 I/O Specifications	3-33

Section 4 Programming Device

4-1 Applicable Programming Devices for CP1E	4-2
4-1-1 Applicable Programming Devices	4-2
4-1-2 CX-Programmer	4-3
4-1-3 Operating Environment and System Configuration.....	4-4
4-1-4 Features of the CX-Programmer.....	4-4
4-1-5 Installing the Software.....	4-7
4-2 Connecting by USB	4-8
4-2-1 Connecting by USB.....	4-8
4-2-2 Installing the USB Driver.....	4-9
4-3 Connection Method with a Serial Port	4-16

Section 5 Installation and Wiring

5-1 Fail-safe Circuits	5-2
5-2 Installation	5-3
5-2-1 Installation Location	5-3
5-2-2 Unit Arrangement.....	5-6
5-2-3 Installation.....	5-7
5-2-4 Connecting Expansion I/O Units and Expansion Units	5-12
5-3 Wiring	5-14
5-3-1 Wiring Procedure	5-14
5-3-2 Wiring Power Supply and Ground Lines	5-14
5-3-3 I/O Wiring	5-17
5-3-4 Wiring Safety and Noise Controls	5-21
5-3-5 Relay Output Noise Reduction Methods.....	5-22

Section 6 Troubleshooting

6-1 Troubleshooting CPU Unit Errors	6-2
6-1-1 Errors and Remedies	6-2
6-1-2 Checking Errors	6-2
6-1-3 Checking Detailed Status.....	6-3
6-1-4 Reading Error Log Information.....	6-3
6-1-5 Types of Errors.....	6-5
6-1-6 Error Processing Flowchart.....	6-6
6-1-7 No Operation When Power Is Supplied	6-7
6-1-8 Fatal Errors	6-7
6-1-9 CPU Errors.....	6-11
6-1-10 Non-fatal Errors.....	6-12
6-1-11 Other Errors	6-14

6-2	Troubleshooting Unit Errors.....	6-15
6-2-1	Inputs	6-15
6-2-2	Outputs.....	6-16
6-2-3	Built-in Analog	6-17
6-2-4	CX-Programmer Connection.....	6-18

Section 7 Maintenance and Inspection

7-1	Periodic Maintenance and Inspection	7-2
7-1-1	Tools Required for Inspections	7-2
7-1-2	Periodic Inspection.....	7-2
7-1-3	Inspection and Maintenance	7-3
7-1-4	Unit Replacement Precautions.....	7-4
7-2	Replacing the Battery in N/NA□□(S□)-type CPU Units	7-5

Section 8 Using Expansion Units and Expansion I/O Units

8-1	Analog Input Units.....	8-2
8-1-1	Overview	8-2
8-1-2	Part Names and Functions.....	8-2
8-1-3	Specifications.....	8-3
8-1-4	Flow of Operation.....	8-7
8-2	Analog Output Units.....	8-15
8-2-1	Overview	8-15
8-2-2	Part Names and Functions.....	8-15
8-2-3	Specifications.....	8-16
8-2-4	Flow of Operation.....	8-20
8-3	Analog I/O Units.....	8-27
8-3-1	CP1W-MAD11 Analog I/O Units	8-27
8-3-2	CP1W-MAD42/CP1W-MAD44 Analog I/O Units.....	8-40
8-4	Temperature Sensor Units.....	8-56
8-4-1	CP1W-TS□1/TS□2 Temperature Sensor Units.....	8-56
8-4-2	CP1W-TS003 Temperature Sensor Units.....	8-71
8-4-3	TS004 Temperature Sensor Units	8-81
8-5	CompoBus/S I/O Link Units	8-92
8-5-1	Overview	8-92
8-5-2	Part Names and Functions.....	8-92
8-5-3	Specifications.....	8-94
8-5-4	Flow of Operation.....	8-94

Section A Appendices

A-1	Dimensions	A-2
A-1-1	CPU Units	A-2
A-1-2	Option Boards	A-5
A-1-3	Expansion I/O Units	A-8
A-1-4	Expansion Units	A-10
A-2	Wiring Diagrams	A-12
A-2-1	CPU Units	A-12
A-2-2	Expansion I/O Units	A-21
A-2-3	Expansion Units	A-28
A-2-4	Serial Communications	A-39

A-3	Wiring for Serial Communications	A-44
A-3-1	Recommended RS-232C Wiring	A-44
A-3-2	Recommended RS-422A/485 Wiring.....	A-47
A-3-3	Converting the Built-in RS-232C Port to RS-422A/485	A-50
A-3-4	Reducing Electrical Noise for External Wiring	A-53
	Index	Index-1
	Revision History	Revision-1

Terms and Conditions Agreement

Warranty, Limitations of Liability

Warranties

- **Exclusive Warranty**

Omron's exclusive warranty is that the Products will be free from defects in materials and workmanship for a period of twelve months from the date of sale by Omron (or such other period expressed in writing by Omron). Omron disclaims all other warranties, express or implied.

- **Limitations**

OMRON MAKES NO WARRANTY OR REPRESENTATION, EXPRESS OR IMPLIED, ABOUT NON-INFRINGEMENT, MERCHANTABILITY OR FITNESS FOR A PARTICULAR PURPOSE OF THE PRODUCTS. BUYER ACKNOWLEDGES THAT IT ALONE HAS DETERMINED THAT THE PRODUCTS WILL SUITABLY MEET THE REQUIREMENTS OF THEIR INTENDED USE.

Omron further disclaims all warranties and responsibility of any type for claims or expenses based on infringement by the Products or otherwise of any intellectual property right.

- **Buyer Remedy**

Omron's sole obligation hereunder shall be, at Omron's election, to (i) replace (in the form originally shipped with Buyer responsible for labor charges for removal or replacement thereof) the non-complying Product, (ii) repair the non-complying Product, or (iii) repay or credit Buyer an amount equal to the purchase price of the non-complying Product; provided that in no event shall Omron be responsible for warranty, repair, indemnity or any other claims or expenses regarding the Products unless Omron's analysis confirms that the Products were properly handled, stored, installed and maintained and not subject to contamination, abuse, misuse or inappropriate modification. Return of any Products by Buyer must be approved in writing by Omron before shipment. Omron Companies shall not be liable for the suitability or unsuitability or the results from the use of Products in combination with any electrical or electronic components, circuits, system assemblies or any other materials or substances or environments. Any advice, recommendations or information given orally or in writing, are not to be construed as an amendment or addition to the above warranty.

See <http://www.omron.com/global/> or contact your Omron representative for published information.

Limitation on Liability; Etc

OMRON COMPANIES SHALL NOT BE LIABLE FOR SPECIAL, INDIRECT, INCIDENTAL, OR CONSEQUENTIAL DAMAGES, LOSS OF PROFITS OR PRODUCTION OR COMMERCIAL LOSS IN ANY WAY CONNECTED WITH THE PRODUCTS, WHETHER SUCH CLAIM IS BASED IN CONTRACT, WARRANTY, NEGLIGENCE OR STRICT LIABILITY.

Further, in no event shall liability of Omron Companies exceed the individual price of the Product on which liability is asserted.

Application Considerations

Suitability of Use

Omron Companies shall not be responsible for conformity with any standards, codes or regulations which apply to the combination of the Product in the Buyer's application or use of the Product. At Buyer's request, Omron will provide applicable third party certification documents identifying ratings and limitations of use which apply to the Product. This information by itself is not sufficient for a complete determination of the suitability of the Product in combination with the end product, machine, system, or other application or use. Buyer shall be solely responsible for determining appropriateness of the particular Product with respect to Buyer's application, product or system. Buyer shall take application responsibility in all cases.

NEVER USE THE PRODUCT FOR AN APPLICATION INVOLVING SERIOUS RISK TO LIFE OR PROPERTY WITHOUT ENSURING THAT THE SYSTEM AS A WHOLE HAS BEEN DESIGNED TO ADDRESS THE RISKS, AND THAT THE OMRON PRODUCT(S) IS PROPERLY RATED AND INSTALLED FOR THE INTENDED USE WITHIN THE OVERALL EQUIPMENT OR SYSTEM.

Programmable Products

Omron Companies shall not be responsible for the user's programming of a programmable Product, or any consequence thereof.

Disclaimers

Performance Data

Data presented in Omron Company websites, catalogs and other materials is provided as a guide for the user in determining suitability and does not constitute a warranty. It may represent the result of Omron's test conditions, and the user must correlate it to actual application requirements. Actual performance is subject to the Omron's Warranty and Limitations of Liability.

Change in Specifications

Product specifications and accessories may be changed at any time based on improvements and other reasons. It is our practice to change part numbers when published ratings or features are changed, or when significant construction changes are made. However, some specifications of the Product may be changed without any notice. When in doubt, special part numbers may be assigned to fix or establish key specifications for your application. Please consult with your Omron's representative at any time to confirm actual specifications of purchased Product.



Errors and Omissions



Information presented by Omron Companies has been checked and is believed to be accurate; however, no responsibility is assumed for clerical, typographical or proofreading errors or omissions.

Safety Precautions

Definition of Precautionary Information

The following notation is used in this manual to provide precautions required to ensure safe usage of a CP-series PLC. The safety precautions that are provided are extremely important to safety. Always read and heed the information provided in all safety precautions.

 WARNING	Indicates an imminently hazardous situation which, if not avoided, will result in death or serious injury. Additionally, there may be severe property damage.
 Caution	Indicates a potentially hazardous situation which, if not avoided, may result in minor or moderate injury, or property damage.

-  Precautions for Safe Use
Indicates precautions on what to do and what not to do to ensure using the product safely.
-  Precautions for Correct Use
Indicates precautions on what to do and what not to do to ensure proper operation and performance.

Symbols



The triangle symbol indicates precautions (including warnings). The specific operation is shown in the triangle and explained in text. This example indicates a precaution for electric shock.



The circle and slash symbol indicates operations that you must not do. The specific operation is shown in the circle and explained in text.



The filled circle symbol indicates operations that you must do. The specific operation is shown in the circle and explained in text. This example shows a general precaution for something that you must do.



The triangle symbol indicates precautions (including warnings). The specific operation is shown in the triangle and explained in text. This example indicates a general precaution.



The triangle symbol indicates precautions (including warnings). The specific operation is shown in the triangle and explained in text. This example indicates a precaution for hot surfaces.

WARNING

Do not attempt to take any Unit apart while the power is being supplied.

Doing so may result in electric shock.



Do not touch any of the terminals or terminal blocks while the power is being supplied.

Doing so may result in electric shock.



Provide safety measures in external circuits (i.e., not in the Programmable Controller), including the following items, to ensure safety in the system if an abnormality occurs due to malfunction of the PLC or another external factor affecting the PLC operation.

Not doing so may result in serious accidents.

- Emergency stop circuits, interlock circuits, limit circuits, and similar safety measures must be provided in external control circuits.
- The PLC will turn OFF all outputs when its self-diagnosis function detects any error or when a severe failure alarm (FALS) instruction is executed. Unexpected operation, however, may still occur for errors in the I/O control section, errors in I/O memory, and errors that cannot be detected by the self-diagnosis function. As a countermeasure for all these errors, external safety measures must be provided to ensure safety in the system.
- The PLC outputs may remain ON or OFF due to deposition or burning of the output relays or destruction of the output transistors. As a countermeasure for such problems, external safety measures must be provided to ensure safety in the system.
- When the 24-VDC output (service power supply to the PLC) is overloaded or short-circuited, the voltage may drop and result in the outputs being turned OFF. As a countermeasure for such problems, external safety measures must be provided to ensure safety in the system.



Fail-safe measures must be taken by the customer to ensure safety in the event of incorrect, missing, or abnormal signals caused by broken signal lines, momentary power interruptions, or other causes.

Serious accidents may result from abnormal operation if proper measures are not provided.



Do not apply the voltage/current outside the specified range to this unit.

It may cause a malfunction or fire.



Caution

Be sure to sufficiently confirm the safety at the destination when you transfer the program or I/O memory or perform procedures to change the I/O memory.

Devices connected to PLC outputs may incorrectly operate regardless of the operating mode of the CPU Unit.



With an E□□(S)-type CPU Unit or with an N/NA□□(S)-type CPU Unit without a Battery, the contents of the DM Area (D) * , Holding Area (H), the Counter Present Values (C), the status of Counter Completion Flags (C), and the status of bits in the Auxiliary Area (A) related to clock functions may be unstable when the power supply is turned ON.

*This does not apply to areas backed up to EEPROM using the DM backup function. If the DM backup function is being used, be sure to use one of the following methods for initialization.

1. Clearing All Areas to All Zeros

Select the *Clear Held Memory (HR/DM/CNT) to Zero* Check Box in the *Startup Data Read Area* in the PLC Setup.

2. Clearing Specific Areas to All Zeros or Initializing to Specific Values
Make the settings from a ladder program.

If the data is not initialized, the unit or device may operate unexpectedly because of unstable data.



Execute online edit only after confirming that no adverse effects will be caused by extending the cycle time.

Otherwise, the input signals may not be readable.



Tighten the screws on the terminal block of the AC power supply section to the torque specified in the user's manual.

The loose screws may result in burning or malfunction.



Do not touch the power supply section when power is being supplied or immediately after the power supply is turned OFF.

The power supply section and I/O terminal blocks will be hot and you may be burned.



Caution

Pay careful attention to the polarities (+/-) when wiring the DC power supply.
A wrong connection may cause malfunction of the system.



When connecting the PLC to a computer or other peripheral device, either ground the 0-V side of the external power supply or do not ground the external power supply at all.

Otherwise the external power supply may be shorted depending on the connection methods of the peripheral device. **DO NOT** ground the 24 V-side of the external power supply, as shown in the following diagram.

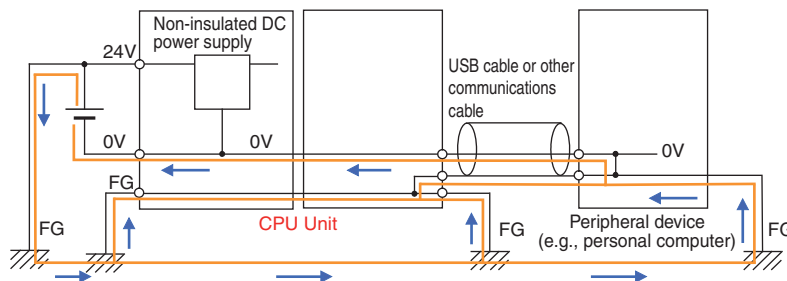

The DM Area (D), Holding Area (H), Counter Completion Flags (C), and Counter Present Values (C) will be held by the Battery if a Battery is mounted in a CP1E-N/NA□□ (S□)D□-□ CPU Unit. When the battery voltage is low, however, I/O memory areas that are held (including the DM, Holding, and Counter Areas) will be unstable. The unit or device may operate unexpectedly because of unstable data.

Use the Battery Error Flag or other measures to stop outputs if external outputs are performed from a ladder program based on the contents of the DM Area or other I/O memory areas.



Sufficiently check safety if I/O bit status or present values are monitored in the Ladder Section Pane or present values are monitored in the Watch Pane.

If bits are set, reset, force-set, or force-reset by inadvertently pressing a shortcut key, devices connected to PLC outputs may operate incorrectly regardless of the operating mode.



Program so that the memory area of the start address is not exceeded when using a word address or symbol for the offset.

For example, write the program so that processing is executed only when the indirect specification does not cause the final address to exceed the memory area by using an input comparison instruction or other instruction.

If an indirect specification causes the address to exceed the area of the start address, the system will access data in other area, and unexpected operation may occur.



 **Caution**

Set the temperature range according to the type of temperature sensor connected to the Unit.

Temperature data will not be converted correctly if the temperature range does not match the sensor.



Do not set the temperature range to any values other than those for which temperature ranges are given in the following table.

An incorrect setting may cause operating errors.



Precautions for Safe Use

Observe the following precautions when using a CP-series PLC.

● Power Supply

- Always use the power supply voltages specified in the user's manuals. An incorrect voltage may result in malfunction or burning.
- Take appropriate measures to ensure that the specified power with the rated voltage and frequency is supplied. Be particularly careful in places where the power supply is unstable. An incorrect power supply may result in malfunction.
- Double-check all wiring and switch settings before turning ON the power supply. Incorrect wiring may result in burning.
- Always turn OFF the power supply to the PLC before attempting any of the following. Not turning OFF the power supply may result in malfunction or electric shock.
 - Mounting or dismounting Expansion Units or Expansion I/O Units
 - Mounting or dismounting Option Boards
 - Setting rotary switches
 - Connecting cables or wiring the system
 - Connecting or disconnecting the connectors

● Installation

- Before touching a Unit, be sure to first touch a grounded metallic object in order to discharge any static build-up. Not doing so may result in malfunction or damage.
- Install the Unit properly as specified in the operation manual. Improper installation of the Unit may result in malfunction.
- Be sure that the terminal blocks, connectors, Option Boards, and other items with locking devices are properly locked into place. Improper locking may result in malfunction.

● Wiring

- Wire correctly according to specified procedures in this manual.
- Keep the wire cuttings out of the Unit when wiring.
- Always use the following size wire when connecting I/O terminals: AWG22 to AWG18 (0.32 to 0.82 mm²).
- When unpacking the Unit, check carefully for any external scratches or other damages. Also, shake the Unit gently and check for any abnormal sound.
- Install external breakers and take other safety measures against short-circuiting in external wiring. Insufficient safety measures against short-circuiting may result in burning.
- Always connect to a ground of 100 Ω or less when installing the Units. Not connecting to a ground of 100 Ω or less may result in electric shock.
- Leave the label attached to the top of the Unit when wiring to prevent the entry of foreign matter. Removing the label may result in malfunction if foreign matter enters the Unit.
- Keep foreign substances, such as wiring chips, from entering into the Units. It may cause a fire, failure or malfunction. Take protective measures especially at the time of construction.
- Remove the label after the completion of wiring to ensure proper heat dissipation. Leaving the label attached may result in malfunction.
- Use crimp terminals for wiring. Do not connect bare stranded wires directly to terminals. Connection of bare stranded wires may result in burning.
- Do not apply voltages to the input terminals in excess of the rated input voltage. Excess voltages may result in burning.

- Do not apply voltages or connect loads to the output terminals in excess of the maximum switching capacity. Excess voltage or loads may result in burning.
- Disconnect the functional ground terminal when performing withstand voltage tests. Not disconnecting the functional ground terminal may result in burning.
- Be sure that all the PLC terminal screws and cable connector screws are tightened to the torque specified in the relevant manuals. The tightening torque for the terminals on the CP1W-CIF11/CIF12 terminal block is 0.28 N·m. Incorrect tightening torque may result in malfunction.
- The following devices can be connected to pin 6 (+5V) on the built-in RS-232C port on the CPU Unit or the RS-232C Option Board (CP1W-CIF01) mounted to the CPU Unit. Do not connect pin 6 to any other device.
 - RS-422A CJ1W-CIF11 Conversion Adapter
 - RS-232C / RS-422A NT-AL001 Conversion Adapter
 - NV3W-M□20L Programmable Terminal
- Use the cables that are specified in the manual for each device. External devices or the CPU Unit may be damaged if a commercially available RS-232C computer cable is used.
- Do not pull on the cables or bend the cables beyond their natural limit. Doing either of these may break the cables.
- Do not place objects on top of the cables or other wiring lines. Doing so may break the cables.

● Handling

- To initialize the DM Area, back up the initial contents for the DM Area to backup memory using one of the following methods.
 - Set the number of words of the DM Area to be backed up starting with D0 in the *Number of CH of DM for backup* Box in the *Startup Data Read Area*.
 - Include programming to back up specified words in the DM Area to built-in EEPROM by turning ON A751.15 (DM Backup Save Start Bit).
- Check the ladder program for proper execution before actually running it on the Unit. Not checking the program may result in an unexpected operation.
- The ladder program and parameter area data in the CP1E CPU Units are backed up in the built-in EEPROM backup memory. The BKUP indicator will light on the front of the CPU Unit when the backup operation is in progress. Do not turn OFF the power supply to the CPU Unit when the BKUP indicator is lit. The data will not be backed up if power is turned OFF and a memory error will occur the next time the power supply is turned ON.
- With a CP1E CPU Unit, data memory can be backed up to the built-in EEPROM backup memory. The BKUP indicator will light on the front of the CPU Unit when backup is in progress. Do not turn OFF the power supply to the CPU Unit when the BKUP indicator is lit. If the power is turned OFF during a backup, the data will not be backed up and will not be transferred to the DM Area in RAM the next time the power supply is turned ON.
- Before replacing the battery, supply power to the CPU Unit for at least 30 minutes and then complete battery replacement within 5 minutes. Memory data may be corrupted if this precaution is not observed.
- The equipment may operate unexpectedly if inappropriate parameters are set. Even if the appropriate parameters are set, confirm that equipment will not be adversely affected before transferring the parameters to the CPU Unit.
- After replacing the CPU Unit, make sure that the required data for the DM Area, Holding Area, and other memory areas has been transferred to the new CPU Unit before restarting operation.
- Do not attempt to disassemble, repair, or modify any Units. Any attempt to do so may result in malfunction, fire, or electric shock.
- Do not drop the Unit or subject the Unit to unusual vibration and shock. Doing so may result in failure or fire.
- Confirm that no adverse effect will occur in the system before attempting any of the following. Not doing so may result in an unexpected operation.
 - Changing the operating mode of the PLC (including the setting of the startup operating mode).

- Force-setting/force-resetting any bit in memory.
- Changing the present value of any word or any set value in memory.
- When replacing parts, be sure to confirm that the rating of a new part is correct. Not doing so may result in malfunction or burning.
- Do not touch the Expansion I/O Unit Connecting Cable while the power is being supplied in order to prevent malfunction due to static electricity.
- Do not turn OFF the power supply to the Unit while data is being transferred.
- When transporting or storing Units or Board, static electricity can destroy LSIs or ICs. Cover the PCBs with a conductive material and maintain the specified storage temperature.
- Do not touch circuit boards or the components mounted to them with your bare hands. There are sharp leads and other parts on the boards that may cause injury if handled improperly.
- Double-check the pin numbers when assembling and wiring the connectors.
- Never short-circuit the positive and negative terminals of a battery or charge, disassemble, heat, or incinerate the battery. Do not subject the battery to strong shocks or deform the battery by applying pressure. Doing any of these may result in leakage, rupture, heat generation, or ignition of the battery. Dispose of any battery that has been dropped on the floor or otherwise subjected to excessive shock. Batteries that have been subjected to shock may leak if they are used.
- Dispose of the product and batteries according to local ordinances as they apply.



- UL standards require that only an experienced engineer can replace the battery. Make sure that an experienced engineer is in charge of battery replacement. Follow the procedure for battery replacement given in this manual.
- The following precaution must be displayed on all products that contain a lithium primary battery (containing at least 6 ppb of perchlorate) and that will be exported to or transported through the State of California in the USA.
Perchlorate Material - special handling may apply. See <http://www.dtsc.ca.gov/hazardouswaste/perchlorate>
A CP1W-BAT01 or CJ1W-BAT01 lithium primary battery (containing at least 6 ppb of perchlorate) can be mounted in a CP1E-N/NA□□D□-□ CPU Unit. Display the precaution given above on your product's packaging box or shipping box if the product contains a CP1W-BAT01 or CJ1W-BAT01 Battery and is exported to or through the State of California in the USA.
- This product is EMC compliant when assembled in a complete PLC system. Refer to the applicable manual for grounding, cable selection, and any other conditions for EMC compliance.
- This is a Class A product for use in industrial environments. In residential environments it may cause radio interference, in which case the user may be required to take adequate measures to reduce interference.

● External Circuits

- Always configure the external circuits to turn ON power to the PLC before turning ON power to the control system. If the PLC power supply is turned ON after the control power supply, temporary errors may result in control system signals because the output terminals on DC Output Units and other Units will momentarily turn ON when power is turned ON to the PLC.
- Fail-safe measures must be taken by the customer to ensure safety in the event that outputs from output terminals remain ON as a result of internal circuit failures, which can occur in relays, transistors, and other elements.
- If the I/O Hold Bit is turned ON, the outputs from the PLC will not be turned OFF and will maintain their previous status when the PLC is switched from RUN or MONITOR mode to PROGRAM mode. Make sure that the external loads will not produce dangerous conditions when this occurs. (When operation stops for a fatal error, including those produced with the FALS instruction, all outputs from PLC will be turned OFF and only the internal output status in the CPU Unit will be maintained.)

Operating Environment Precautions

- **Perform installation following the instructions in this manual**

Follow the instructions in this manual to correctly perform installation.

- **Do not operate the control system in the following locations**

- Locations subject to direct sunlight
- Locations subject to temperatures or humidity outside the range specified in the specifications
- Locations subject to condensation as the result of severe changes in temperature
- Locations subject to corrosive or flammable gases
- Locations subject to dust (especially iron dust) or salts
- Locations subject to exposure to water, oil, or chemicals
- Locations subject to shock or vibration
- Locations subject to direct rain fall
- Locations subject to direct strong UV

- **Take countermeasures in the following locations**

- Locations subject to static electricity or other forms of noise
- Locations subject to strong electromagnetic fields
- Locations subject to possible exposure to radioactivity
- Locations close to power supplies

Regulations and Standards

Conformance to EC Directives

Applicable Directives

- EMC Directives
- Low Voltage Directive

Concepts

● EMC Directives

OMRON devices are electrical components that are designed to be built into equipment and manufacturing systems. OMRON devices that comply with EMC Directives also conform to the related EMC standards*, so that they can be more easily built into other devices or the overall machine. Whether the products conform to the standards in the system used by the customer, however, must be checked by the customer.

EMC-related performance of the OMRON devices that comply with EC Directives will vary depending on the configuration, wiring, and other conditions of the equipment or control panel on which the OMRON devices are installed. The customer must, therefore, perform the final check to confirm that devices and the overall machine conform to EMC standards.

* The applicable EMC (Electromagnetic Compatibility) standard is EN61131-2.

● Low Voltage Directive

Always ensure that devices operating at voltages of 50 to 1,000 VAC and 75 to 1,500 VDC meet the required safety standards for the PLC (EN 61131-2).

● Conformance to EC Directives

The CP1E PLCs comply with EC Directives. To ensure that the machine or device in which the CP1E PLC is used complies with EC Directives, the PLC must be installed as follows:

- The CP-series PLC must be installed within a control panel.
- CP-series PLCs complying with EC Directives also conform to EN61131-2. Radiated emission characteristics (10-m regulations) may vary depending on the configuration of the control panel used, other devices connected to the control panel, wiring, and other conditions. You must therefore confirm that the overall machine or equipment complies with EC Directives.
- A SYSMAC CP-series PLC is a class A product (for an industrial environment). In residential areas it may cause radio interference, in which case the user may be required to take adequate measures to reduce interference.

Trademarks

SYSMAC is a registered trademark for Programmable Controllers made by OMRON Corporation.

CX-One is a registered trademark for Programming Software made by OMRON Corporation.

Windows is a registered trademark of Microsoft Corporation.

Other system names and product names in this document are the trademarks or registered trademarks of their respective companies.

Related Manuals

The following manuals are related to the CP1E. Use them together with this manual.

Manual name	Cat. No.	Model numbers	Application	Contents
SYSMAC CP Series CP1E CPU Unit Hardware User's Manual (this manual)	W479	CP1E-E□□SD□-□ CP1E-N□□SDD□-□ CP1E-E□□DD□-□ CP1E-N□□DD□-□ CP1E-NA□□DD□-□	To learn the hardware specifications of the CP1E PLCs	Describes the following information for CP1E PLCs. <ul style="list-style-type: none"> • Overview and features • Basic system configuration • Part names and functions • Installation and settings • Troubleshooting
			Use this manual together with the CP1E CPU Unit Software User's Manual (Cat. No. W480) and Instructions Reference Manual (Cat. No. W483).	
SYSMAC CP Series CP1E CPU Unit Software User's Manual	W480	CP1E-E□□SD□-□ CP1E-N□□SDD□-□ CP1E-E□□DD□-□ CP1E-N□□DD□-□ CP1E-NA□□DD□-□	To learn the software specifications of the CP1E PLCs	Describes the following information for CP1E PLCs. <ul style="list-style-type: none"> • CPU Unit operation • Internal memory • Programming • Settings • CPU Unit built-in functions <ul style="list-style-type: none"> • Interrupts • High-speed counter inputs • Pulse outputs • Serial communications • Analog I/O function • Other functions
			Use this manual together with the CP1E CPU Unit Hardware User's Manual (Cat. No. W479) and Instructions Reference Manual (Cat. No. W483).	
SYSMAC CP Series CP1E CPU Unit Instructions Reference Manual	W483	CP1E-E□□SD□-□ CP1E-N□□SDD□-□ CP1E-E□□DD□-□ CP1E-N□□DD□-□ CP1E-NA□□DD□-□	To learn programming instructions in detail	Describes each programming instruction in detail. When programming, use this manual together with the CP1E CPU Unit Software User's Manual (Cat. No. W480).
CS/CJ/CP/NSJ Series Communications Commands Reference Manual	W342	CS1G/H-CPU□□H CS1G/H-CPU□□-V1 CS1D-CPU□□H CS1D-CPU□□S CS1W-SCU□□-V1 CS1W-SCB□□-V1 CJ1G/H-CPU□□H CJ1G-CPU□□P CJ1M-CPU□□ CJ1G-CPU□□ CJ1W-SCU□□-V1	To learn communications commands for CS/CJ/CP/NSJ-series Controllers in detail	Describes <ol style="list-style-type: none"> 1) C-mode commands and 2) FINS commands in detail. Read this manual for details on C-mode and FINS commands addressed to CPU Units.
			Note This manual describes commands addressed to CPU Units. It does not cover commands addressed to other Units or ports (e.g., serial communications ports on CPU Units, communications ports on Serial Communications Units/Boards, and other Communications Units).	
SYSMAC CP Series CP1L/CP1E CPU Unit Introduction Manual	W461	CP1L-L10D□-□ CP1L-L14D□-□ CP1L-L20D□-□ CP1L-M30D□-□ CP1L-M40D□-□ CP1L-M60D□-□ CP1E-E□□DD□-□ CP1E-N□□DD□-□ CP1E-NA□□DD□-□	To learn the basic setup methods of the CP1L/CP1E PLCs	Describes the following information for CP1L/CP1E PLCs. <ul style="list-style-type: none"> • Basic configuration and component names • Mounting and wiring • Programming, data transfer, and debugging using the CX-Programmer • Application program examples
CX-Simulator Operation Manual	W366	CXONE-AL□□C-V4/ AL□□D-V4	Operating procedures for CX-Simulator Simulation Support Software for Windows computers Using simulation in the CX-Programmer with CX-Programmer	Describes the operating procedures for the CX-Simulator.

1

Overview and Specifications

This section gives an overview of the CP1E, describes its features, and provides its specifications.

1-1 CP1E Overview	1-2
1-1-1 Overview of Features	1-2
1-1-2 Features	1-3
1-2 Basic Operating Procedure	1-8
1-3 Specifications	1-9
1-3-1 General Specifications	1-9
1-3-2 Characteristics	1-10
1-3-3 Functional Specifications	1-12
1-4 Difference between E/N/NA□□-type and E/N□□S(1)-type.	1-14

1-1 CP1E Overview

1-1-1 Overview of Features

The SYSMAC CP1E Programmable Controller is a package-type PLC made by OMRON that is designed for easy application. The CP1E includes E□□(S)-type CPU Units (basic models) for standard control operations using basic, movement, arithmetic, and comparison instructions, and N/NA□□(S□)-type CPU Units (application models) that supports connections to Programmable Terminals, Inverters, and Servo Drives.

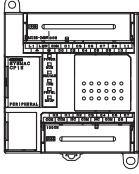
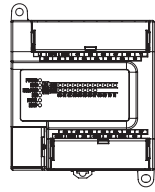
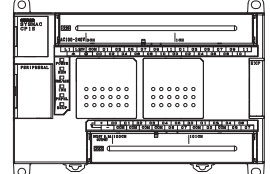
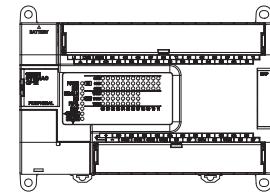
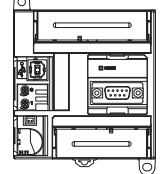
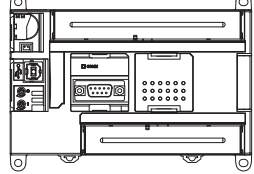
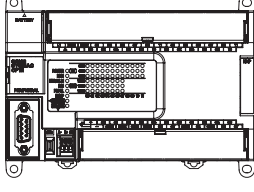
	Basic Models		CP1E Application Models		
	E□□(S)-type CPU Units		N□□(S□)-type CPU Units		NA□□-type CPU Units
	CPU with 10, 14 or 20 I/O Points	CPU Unit with 30, 40 or 60 I/O Points	CPU with 14 or 20 I/O Points	CPU Unit with 30, 40 or 60 I/O Points	CPU Unit with 20 I/O Points
Appearance	E□□-type  E□□S-type 	E□□-type  E□□S-type 	N□□-type 	N/NA□□-type  N□□S(1)-type 	
I/O points	E□□ 10/14/20/30/40 E□□S 14/20/30/40/60		N□□ 14/20/30/40/60 N□□S(1) 30/40/60		20
Program capacity	2K steps		8K steps		
DM Area capacity	2K words Of these 1,500 words can be written to the built-in EEPROM.		8K words Of these 7,000 words can be written to the built-in EEPROM.		
Mounting Expansion I/O Units and Expansion Units	Not possible.	3 Units maximum	Not possible.	3 Units maximum	
Model with transistor outputs	Available (CPU Unit with 10 I/O points only)		Available		
Pulse outputs	Not supported.		Supported (Model with transistor outputs only)		
Built-in serial communications port	Not provided.		RS-232C port provided RS-485 port provided (N□□S1-type only)		
Built-in analog	Not available.		Not available.		Available
Option Board	Not supported.		Not supported.	N/NA□□-type: Supported (for one port) N□□S(1)-type: Not Supported	
Connection port for Programming Device	USB port		USB port		
Clock	Not provided.		Provided		
Using a Battery	Cannot be used.		Can be used (sold separately).		
Backup time of built-in capacitor	50 hours at 25°C		40 hours at 25°C		
Battery-free operation	Always battery-free operation. Only data in the built-in EEPROM will be retained if power is interrupted for longer than 50 hours.		Battery-free operation if no battery is attached. Only data in the built-in EEPROM will be retained if power is interrupted for longer than 40 hours.		



Precautions for Correct Use

For CP1E CPU Units, the following I/O memory area will be unstable after a power interruption.

- DM Area (D) (excluding words backed up to the EEPROM using the DM function)
- Holding Area (H)
- Counter Present Values and Completion Flags (C)
- Auxiliary Area related to clock functions(A)

Mount the CP1W-BAT01 Battery (sold separately) to an N/NA□□(S□)-type CPU Unit if data in the above areas need to be retained after a power interruption. A Battery cannot be mounted to an E□□(S)-type CPU Unit.

1-1-2 Features

● System Configuration

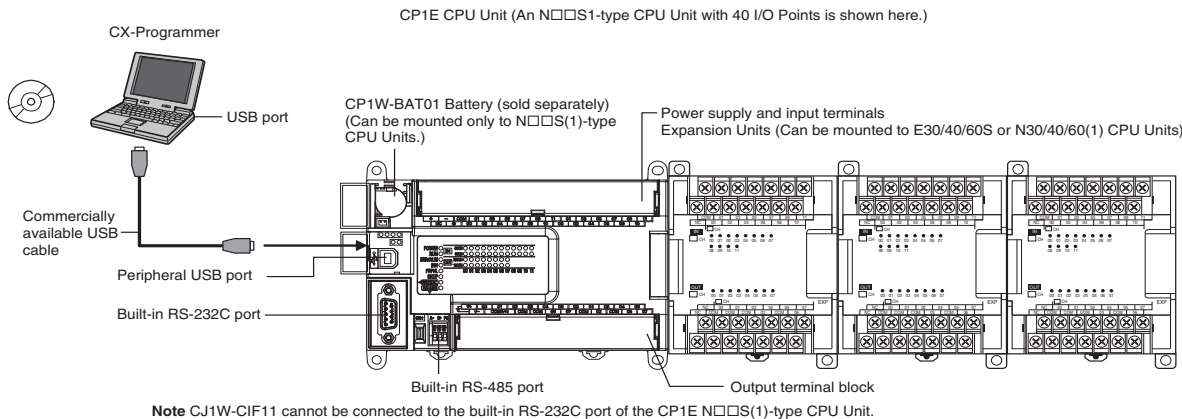
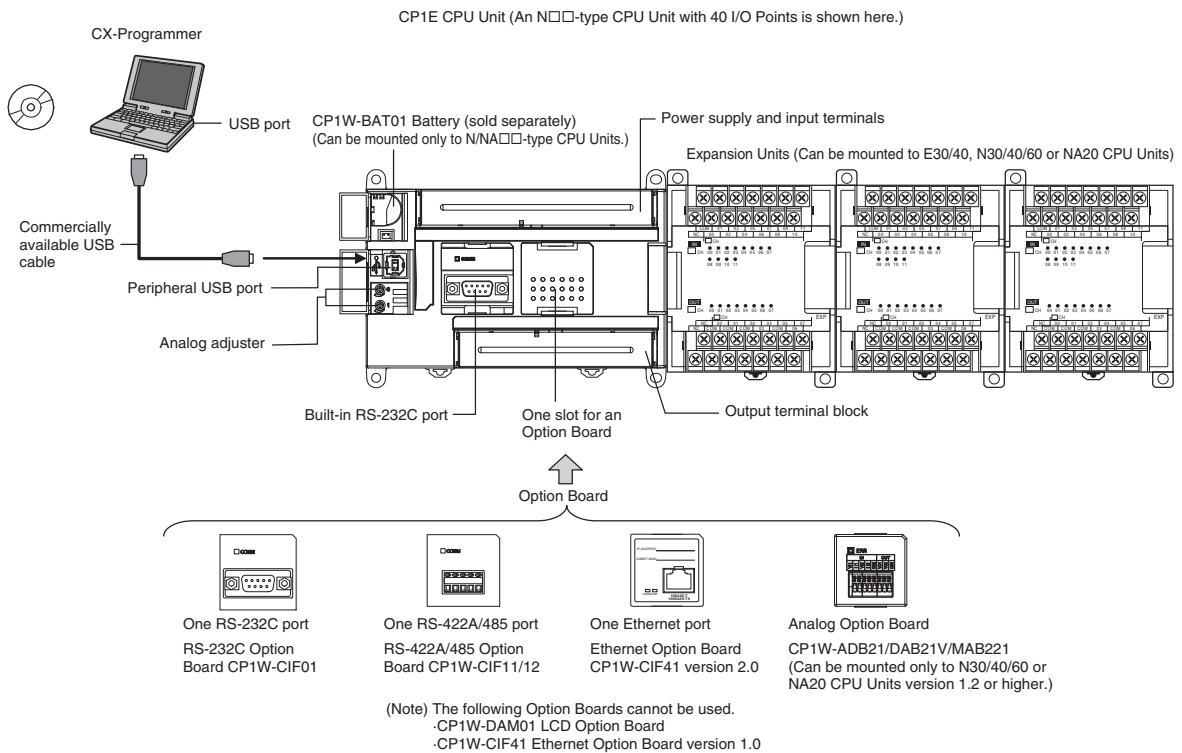

Programming, Setting, and Monitoring with the CX-Programmer

The CX-Programmer is used as the Programming Device for the CP1E.

Easy Connection with Computers Using Commercially Available USB Cables

The CX-Programmer is connected using a commercially available USB cable between the computer's USB port and the built-in peripheral USB port of the CP1E.

With E30/40/60(S), N30/40/60(S□) or NA20 CPU Units, Add I/O by Connecting Expansion I/O Units

A total of up to three of the following Expansion I/O Units can be connected to an E30/40/60(S), N30/40/60(S□) or NA20 CPU Unit. (The total of three Units must also include Expansion Units.)

24-input/16-output Unit, 32-output Unit, 12-input/8-output Unit, 16-output Unit, 8-input Unit, or 8-output Unit

With E30/40/60(S), N30/40/60(S□) or NA20 CPU Units, Add Analog I/O or Temperature Inputs by Connecting Expansion Units

With an E30/40/60(S), N30/40/60(S□) or NA20 CPU Unit, a total of up to three of the following Expansion Units can be connected. (The total of three Units must also include Expansion I/O Units.)

Analog I/O Unit, Analog Input Unit, Analog Output Unit, Temperature Sensor Units, CompoBus/S I/O Link Unit

Quick-response Inputs

By setting a built-in input to quick-response input operation, inputs with signal widths as small as 50 μ s can be read with certainty regardless of the cycle time.

Up to six quick-response inputs can be used.

Quick-response signal to photomicrosensor or other device

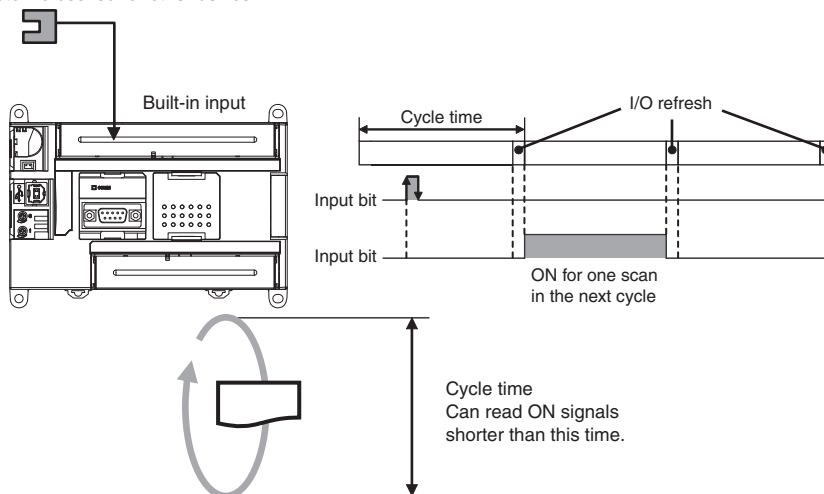

Note The user setting in the PLC Setup determines if each input is a quick-response input, normal input, interrupt input, or high-speed counter input.

Input Interrupts

An interrupt task can be started when a built-in input turns ON or turns OFF .
Up to six interrupt inputs can be used.

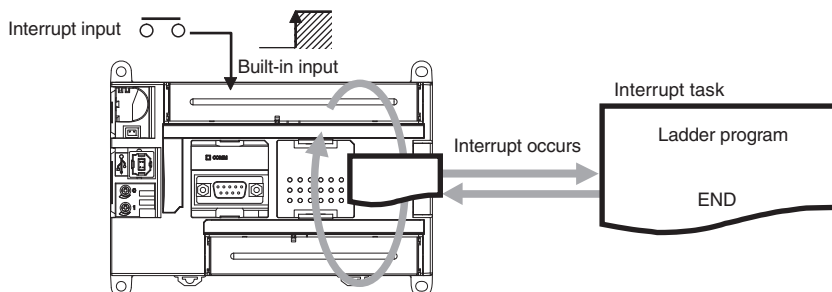

Note The user setting in the PLC Setup determines if each input is a quick-response input, normal input, interrupt input, or high-speed counter input.

Complete High-speed Counter Functionality

A high-speed counter input can be used by connecting a rotary encoder to a built-in input. A CP1E CPU Unit is equipped with more than one high-speed counter input, making it possible to control devices for multiple axes with a single PLC.

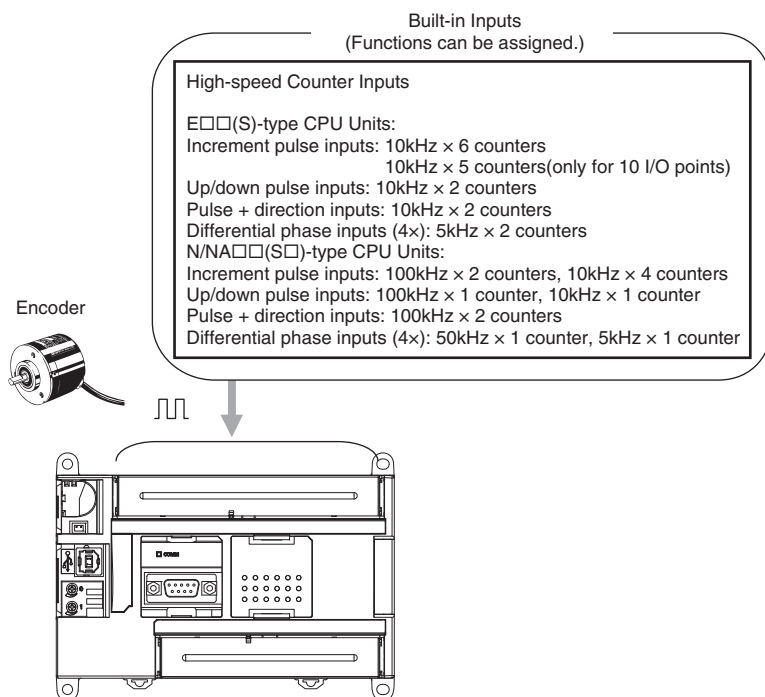

Note The user setting in the PLC Setup determines if each input is a quick-response input, normal input, interrupt input, or high-speed counter input.

- High-speed counters can be used for high-speed processing, using either target value comparison or range comparison with the counter's PV to create interrupts.
An interrupt task can be started when the count reaches a specified value or falls within a specified range.
- High-speed counter input frequency (speed) can be measured.
The input pulse frequency can be measured using the PRV instruction (counter 0 only).

Versatile Pulse Control for Transistor Output CPU Units

Fixed duty ratio pulse outputs can be output from the CPU Unit's built-in outputs and used to perform positioning or speed control with a servomotor or a stepping motor that accepts pulse inputs.

Two pulse outputs at 100 kHz are provided as standard features.

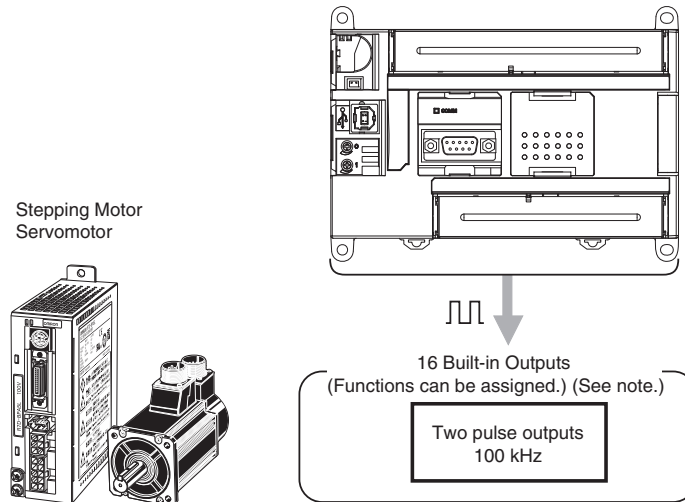

Note The instruction used to control each output determines whether it is used as a normal output, pulse output, or PWM output.

- **Positioning is possible with Trapezoidal Acceleration and Deceleration**

Trapezoidal acceleration and deceleration can be used for positioning using the PULSE OUTPUT (PLS2) instruction.

- **Jogging Can Be Performed**

Jogging can be performed by executing the SPED or ACC instruction.

- **Origin Searches and Origin Returns Can Be Performed Using the ORIGIN SEARCH Instruction**

An accurate origin search combining all I/O signals can be executed with a single instruction. It is also possible to move directly to an established origin using the ORIGIN SEARCH (ORG) instruction.

PWM Outputs for Transistor Output CPU Units

Lighting and power control can be performed by outputting variable duty ratio pulse (PWM) output signals from the CPU Unit's built-in outputs.

Built-in RS-232C Port for N/NA□□(S□)-type CPU Units

The N/NA□□(S□)-type CPU Units have one built-in RS-232C port as a standard feature.

Built-in RS-485 Port for N□□S1-type CPU Units

The N□□S1-type CPU Units have one built-in RS-485 port as a standard feature.

Mounting Serial Option Boards to N30/40/60 or NA20 CPU Units

One Serial Communications Option Board with one RS-232C port or one RS-422A/485 port can be added to an N30/40/60 or NA20 CPU Unit. With the serial communications port, it is easy to connect to general components, such as barcode readers, and other components such as PTs, other CP-series PLCs, and Inverters.

Note Serial Option Boards cannot be mounted to the N□□S(1)-type CPU Unit.

NS-series PT, Barcode Reader, etc.

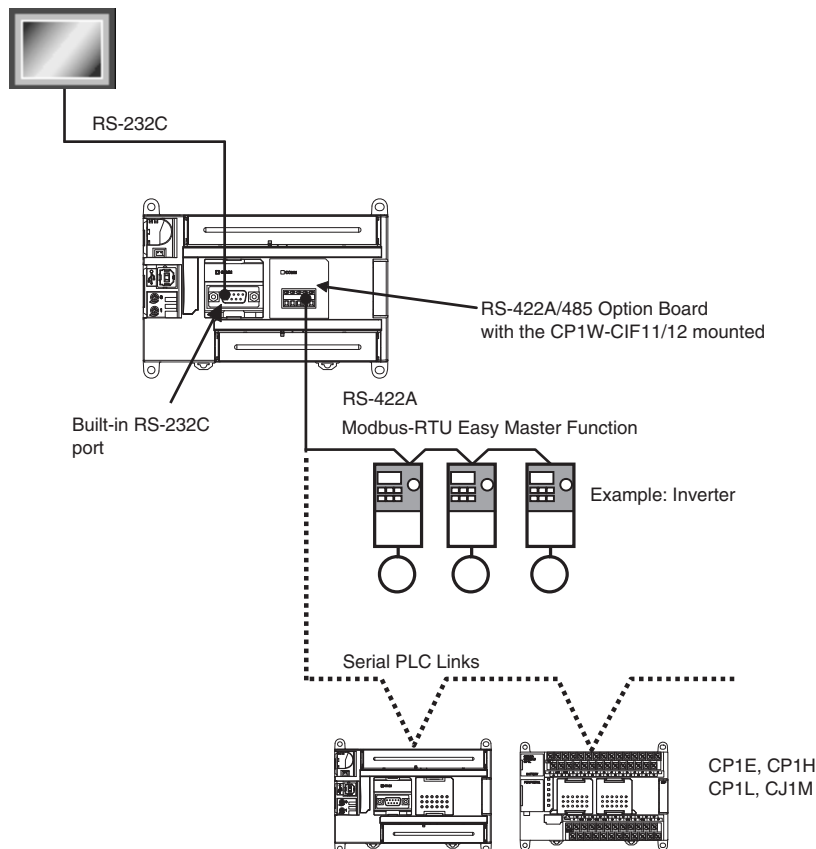

Built-in Analog for NA-type CPU Units

The NA-type CPU Units have analog functionality, with 2 analog voltage/current inputs and 1 analog voltage/current output built in.

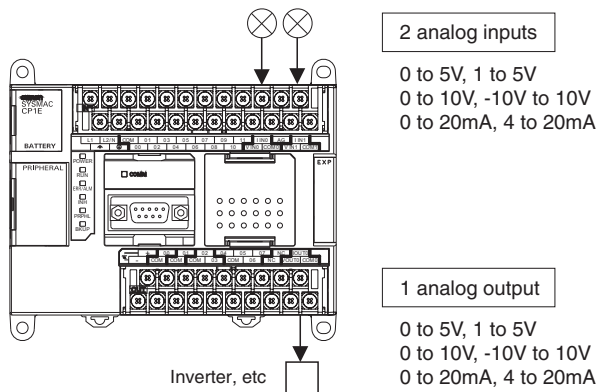

- A range of applications is at a resolution of 6,000.
- Application is also possible for process-control sensor input or inverter control without using Expansion I/O Units.

1-2 Basic Operating Procedure

In general, use the following procedure.

1. Setting Devices and Hardware

Connect the CPU Unit, Expansion I/O Units, and Expansion Units.
Set the DIP switches on the Option Board and Expansion Units as required.

Refer to *Section 3 Part Names and Functions* and *Section 5 Installation and Wiring* in the *CP1E CPU Unit Hardware User's Manual* (Cat. No. W479).

2. Wiring

Wire the power supply, I/O, and communications.

Refer to *Section 5 Installation and Wiring* in the *CP1E CPU Unit Hardware User's Manual* (Cat. No. W479).

3. Connecting Online to the PLC

Connect the personal computer online to the PLC.

Refer to *Section 4 Programming Device* in the *CP1E CPU Unit Hardware User's Manual* (Cat. No. W479).

4. I/O Allocations

Allocations for built-in I/O on the CPU Unit are predetermined and memory is allocated automatically to Expansion I/O Units and Expansion Units, so the user does not have to do anything.

Refer to *Section 6 I/O Allocation* in the *CP1E CPU Unit Software User's Manual* (Cat. No. W480).

5. Software Setup

Make the PLC software settings.

With a CP1E CPU Unit, all you have to do is set the PLC Setup.

When using an E□□(S)-type CPU Unit or when using an N/NA□□(S)-type CPU Unit without a Battery, be sure to consider selecting the *Clear retained memory area (HR/DM/CNT)* Check Box in the *Startup Data Read Area* in the PLC Settings.

Refer to *3-2-4 Initializing I/O Memory at Startup* and *Section 7 PLC Setup* in the *CP1E CPU Unit Software User's Manual* (Cat. No. W480).

6. Writing the Programs

Write the programs using the CX-Programmer.

Refer to *Section 4 Programming Concepts* in the *CP1E CPU Unit Software User's Manual* (Cat. No. W480).

7. Checking Operation

Check the I/O wiring and the Auxiliary Area settings, and perform trial operation.

The CX-Programmer can be used for monitoring and debugging.

Refer to *Section 8 Overview and Allocation of Built-in Functions* in the *CP1E CPU Unit Software User's Manual* (Cat. No. W480).

8. Basic Program Operation

Set the operating mode to RUN mode to start operation.

1-3 Specifications

1-3-1 General Specifications

The following table lists the general specifications of CP1E CPU Units.

Item	AC power supply	DC power supply	
Model	CP1E-□□□□□-A CP1E-□□□□(1)D□-A	CP1E-□□□□□-D CP1E-□□□□(1)D□-D	
Enclosure	Mounted in a panel		
Dimensions (H × D × W)	E/N/NA□□-type CPU Unit with 10 I/O points (CP1E-E10D□-□): 90mm ¹ × 85mm ² × 66mm CPU Unit with 14 or 20 I/O points (CP1E-□14/20D□-□): 90mm ¹ × 85mm ² × 86mm CPU Unit with 30 I/O points (CP1E-□30D□-□): 90mm ¹ × 85mm ² × 130mm CPU Unit with 40 I/O points (CP1E-□40D□-□): 90mm ¹ × 85mm ² × 150mm CPU Unit with 60 I/O points (CP1E-N60D□-□): 90mm ¹ × 85mm ² × 195mm CPU Unit with 20 I/O points and built-in analog (CP1E-NA20D□-□): 90mm ¹ × 85mm ² × 130mm E/N□□□(1)-type CPU Unit with 14 or 20 I/O points (CP1E-□14D/20SD□-□): 90mm ¹ × 78.6mm ² × 86mm CPU Unit with 30 I/O points (CP1E-□30S(1)D□-□): 90mm ¹ × 78.6mm ² × 130mm CPU Unit with 40 I/O points (CP1E-□40S(1)D□-□): 90mm ¹ × 78.6mm ² × 150mm CPU Unit with 60 I/O points (CP1E-□60S(1)D□-□): 90mm ¹ × 78.6mm ² × 195mm		
Weight	CPU Unit with 10 I/O points (CP1E-E10D□-□): 300g max. CPU Unit with 14 I/O points (CP1E-□14(S)D□-□): 360g max. CPU Unit with 20 I/O points (CP1E-□20(S)D□-□): 370g max. CPU Unit with 30 I/O points (CP1E-□30(S)D□-□): 600g max. CPU Unit with 40 I/O points (CP1E-□40(S)D□-□): 660g max. CPU Unit with 60 I/O points (CP1E-□60(S)D□-□): 850g max. CPU Unit with 20 I/O points and built-in analog (CP1E-NA20D□-□): 680g max.		
Electrical specifications	Supply voltage	100 to 240 VAC 50/60 Hz	24 VDC
	Operating voltage range	85 to 264 VAC	20.4 to 26.4 VDC
	Power consumption	15 VA/100 VAC max. (CP1E-□10/14/20(S)D□-A) 25 VA/240 VAC max.	9W max. (CP1E-E10D□-D) 13W max. (CP1E-N14/20D□-D)
		50 VA/100 VAC max. (CP1E-NA20D□-A) 70 VA/240 VAC max. (CP1E-□30/40/60(S)D□-A)	20W max. (CP1E-NA20D□-D) CP1E-N30/40/60(S)D□-D)*4
	Inrush current	120 VAC, 20 A for 8 ms max. for cold start at room temperature 240 VAC, 40 A for 8 ms max. for cold start at room temperature	24 VDC, 30A for 20 ms max. for cold start at room temperature
	External power supply *3	Not provided. (CP1E-□10/14/20(S)D□-A) 24 VDC, 300 mA (CP1E-NA20D□-A CP1E-□30/40/60D□-A CP1E-□30/40/60S(1)DR-A)	Not provided.
	Insulation resistance	20 MΩ min. (at 500 VDC) between the external AC terminals and GR terminals	Except between DC primary current and DC secondary current
	Dielectric strength	2,300 VAC 50/60Hz for 1 min between AC external and GR terminals leakage current: 5 mA max.	Except between DC primary current and DC secondary current
Power interrupt time	10 ms min.	2 ms min.	
Application environment	Ambient operating temperature	0 to 55°C	
	Ambient humidity	10% to 90%	
	Atmosphere	No corrosive gas.	
	Ambient storage temperature	-20 to 75°C (excluding battery)	
	Altitude	2,000 m max.	
	Pollution degree	2 or less: Conforms to JIS B3502 and IEC 61131-2.	
	Noise resistance	2 kV on power supply line (Conforms to IEC61000-4-4.)	
	Overvoltage category	Category II: Conforms to JIS B3502 and IEC 61131-2.	
	EMC immunity level	Zone B	
	Vibration resistance	Conforms to JIS 60068-2-6. 5 to 8.4 Hz with 3.5-mm amplitude, 8.4 to 150 Hz Acceleration of 9.8 m/s ² for 100 min in X, Y, and Z directions (10 sweeps of 10 min each = 100 min total)	
Shock resistance	Conforms to JIS 60068-2-27. 147 m/s ² , 3 times in X, Y, and Z directions		
Terminal block	Fixed (not removable)		
Terminal screw size	M3		
Applicable standards	Conforms to EC Directives.		
Grounding method	Ground to 100Ω or less.		

*1 Total of 110 mm with mounting brackets.

*2 Excluding cables.

*3 Use the external power supply to power input devices. Do not use it to drive output devices.

*4 This is the rated value for the maximum system configuration. Use the following formula to calculate power consumption for CPU Units with DC power.
 Formula: DC power consumption = (5V current consumption × 5 V/70% (internal power efficiency) + 24V current consumption) × 1.1 (current fluctuation factor)
 The above calculation results show that a DC power supply with a greater capacity is required.

*5 The general specifications of the Expansion I/O Units and Expansion Units are measured under the same conditions as the CPU Units.

1-3-2 Characteristics

The following table gives the characteristics of CP1E CPU Units.

Item		CP1E-E□□D□-□ CP1E-E□□SD□-□	CP1E-N□□D□-□ CP1E-NA□□D□-□ CP1E-N□□S(1)D□-□	
Program capacity		2K steps (8 KB) including the symbol table, comments, and program indices of the CX-Programmer	8K steps (32 KB) including the symbol table, comments, and program indices of the CX-Programmer	
Control method		Stored program method		
I/O control method		Cyclic scan with immediate refreshing		
Program language		Ladder programs		
Instructions		Approximately 200		
Processing speed	Overhead processing time	0.4 ms		
	Instruction execution times	Basic instructions: 1.19 μs Special instructions: 7.9 μs		
Number of CP1W-series Expansion I/O Units and Expansion Units connected		CP1E-□10/14/20(S)D□-□: None CP1E-□30/40/60(S)D□-□/NA20D□-□: 3 units		
Maximum number of I/O points		CP1E-E10D□-□ : 10 CP1E-□14(S)D□-□: 14 CP1E-□20(S)D□-□: 20 CP1E-□30(S)D□-□: 150 (30 built in, 40 × 3 expansion) CP1E-□40(S)D□-□: 160 (40 built in, 40 × 3 expansion) CP1E-□60(S)D□-□: 180 (60 built in, 40 × 3 expansion) CP1E-NA20D□-□ : 140 (20 built in, 40 × 3 expansion)		
Built-in I/O		CP1E-E10D□-□ : 10 (6 inputs, 4 outputs) CP1E-□14(S)D□-□: 14 (8 inputs, 6 outputs) CP1E-□20(S)D□-□: 20 (12 inputs, 8 outputs) CP1E-□30(S)D□-□: 30 (18 inputs, 12 outputs) CP1E-□40(S)D□-□: 40 (24 inputs, 16 outputs) CP1E-□60(S)D□-□: 60 (36 inputs, 24 outputs) CP1E-NA20D□-□ : 20 (12 inputs, 8 outputs)		
Built-in input functions	High-speed counters	High-speed counter mode/maximum frequency	Incremental Pulse Inputs 10 kHz: 6 counters 5 counters (only for 10 I/O points) Up/Down Inputs 10 kHz: 2 counters Pulse + Direction Inputs 10 kHz: 2 counters Differential Phase Inputs (4x) 5 kHz: 2 counters	Incremental Pulse Inputs 100 kHz: 2 counters, 10 kHz: 4 counters Up/Down Inputs 100 kHz: 1 counters, 10 kHz: 1 counters Pulse + Direction Inputs 100 kHz: 2 counters Differential Phase Inputs (4x) 50 kHz: 1 counter, 5 kHz: 1 counter
		Counting mode	<ul style="list-style-type: none"> Linear mode Ring mode 	
		Count value	32 bits	
		Counter reset modes	<ul style="list-style-type: none"> Phase Z and software reset (excluding increment pulse input) Software reset 	
	Control method	Target Matching Range Comparison		
	Input interrupts	6 inputs (4 inputs only for 10 I/O points) Interrupt input pulse width: 50 μs min.		
	Quick-response Inputs	6 inputs (4 inputs only for 10 I/O points) Input pulse width: 50 μs min.		
Normal input	Input constants	Delays can be set in the PLC Setup (0 to 32 ms, default: 8 ms). Set values: 0, 1, 2, 4, 8, 16, or 32 ms		
Built-in output functions	Pulse outputs (Models with transistor outputs only)	Pulse output method and output frequency	Pulse output function not included	Pulse + Direction Mode 1 Hz to 100 kHz: 2 counters
		Output mode		<ul style="list-style-type: none"> Continuous mode (for speed control) Independent mode (for position control)
		Number of output pulses		<ul style="list-style-type: none"> Relative coordinates: 0000 0000 to 7FFF FFFF hex (0 to 2147483647) Absolute coordinates: 8000 0000 to 7FFF FFFF hex (-2147483647 to 2147483647)
		Acceleration/deceleration curves		Trapezoidal acceleration and deceleration (Cannot perform S-curve acceleration and deceleration.)
		Changing SVs during instruction execution		Only target position can be changed.
	Origin searches		Included	
	PWM outputs (Models with transistor outputs only)	Frequency	PWM output function not included	2.0 to 6,553.5 Hz (in increments of 0.1 Hz) with 1 output or 2 Hz to 32,000 Hz (in increments of 1 Hz) with 1 output
Duty factor			0.0% to 100.0% (in increments of 0.1%) Accuracy: +1%/-0% at 2 Hz to 10,000 Hz and +5%/-0% at 10,000 Hz to 32,000 kHz	
Output mode			Continuous Mode	
Built-in analog	Analog input	Analog function not included		
	Analog output	Setting range: 0 to 6,000 (2 channels only for NA-type) Setting range: 0 to 6,000 (1 channel only for NA-type)		
Analog adjusters		E/N/NA□□-type CPU Units: 2 adjusters (Setting range: 0 to 255) E/N□□S(1)-type CPU Units: None		
Communications	B-type peripheral USB port		Conforming to USB 2.0 B-type connector	
		Transmission distance	5 m max.	

Item		CP1E-E□□D□-□ CP1E-E□□SD□-□	CP1E-N□□D□-□ CP1E-NA□□D□-□ CP1E-N□□S(1)D□-□
Communications	Built-in RS-232C port	No built-in RS-232C port	Interface: Conforms to EIA RS-232C.
			Half duplex
			Start-stop
			1.2, 2.4, 4.8, 9.6, 19.2, 38.4, 57.6, or 115.2 kbps
			15 m max.
			<ul style="list-style-type: none"> • Host Link • 1:N NT Link • No-protocol mode • Serial PLC Links (master, slave) • Modbus-RTU Easy Master
	Built-in RS-485 port	No built-in RS-485 port	N30/40/60S1-type only
			Interface: Conforms to EIA RS-485
			Half duplex
			Start-stop
			1.2, 2.4, 4.8, 9.6, 19.2, 38.4, 57.6, or 115.2 kbps
			50 m max.
Serial option port	Option Board cannot be mounted.	1 port (Option Board can be mounted only to N30/40/60 and NA20 CPU Units.)	
		<ul style="list-style-type: none"> • One RS-232C port: CP1W-CIF01 (Half duplex, Start-stop) • One RS-422A/485 port (not isolated): CJ1W-CIF11 (Half duplex, Start-stop) • One RS-422A/485 port (isolated): CP1W-CIF12 (Half duplex, Start-stop) • One Ethernet port: CP1W-CIF41 version 2.0(100Base-TX) • One Analog Option Board: CP1W-MAB221/ADB21/DAB21V (Can be mounted only to N30/40/60 and NA20 CPU Units version 1.2 or higher.) 	
		Depends on Option Board.	
		Depends on Option Board.	
		1.2, 2.4, 4.8, 9.6, 19.2, 38.4, 57.6, or 115.2 kbps	
		<ul style="list-style-type: none"> • Host Link • 1:N NT Link • No-protocol mode • Serial PLC Links (master, slave) • Modbus-RTU Easy Master 	
Number of tasks		17 <ul style="list-style-type: none"> • One cyclic task • One scheduled interrupt task (always interrupt task 1) • Six input interrupt tasks (interrupt tasks 2 to 7) • Sixteen high-speed counter interrupt tasks (interrupt tasks 1 to 16) 	
Maximum subroutine number		128	
Maximum jump number		128	
Scheduled interrupt tasks		1 interrupt task	
Clock		Clock function not included. The time of error occurrence displays 01-01-01 01:01:01 Sunday.	Included. Accuracy (monthly deviation):-4.5 min to -0.5 min at ambient temperature of 55°C -2.0 min to +2.0 min at ambient temperature of 25°C -2.5 min to +1.5 min at ambient temperature of 0°C
Memory backup	Built-in EEPROM	Ladder programs and parameters are automatically saved to built-in EEPROM A section of the Data Memory Area can be saved to the built-in EEPROM.	
	Battery backup *With CP1W-BAT01 Battery (optional)	Battery cannot be mounted.	CP1W-BAT01 can be used. Maximum battery service life: 5 years Backup Time Guaranteed value (ambient temperature: 55°C): 13,000 hours (approx. 1.5 years) Effective value (ambient temperature: 25°C): 43,000 hours (approx. 5 years)
CIO Area	Input Bits	1,600 bits (100 words): CIO 0.00 to CIO 99.15 (CIO 00 to CIO 99)	
	Output Bits	1,600 bits (100 words): CIO 100.00 to CIO 199.15 (CIO 100 to CIO 199)	
	Serial PLC Link Words	1,440 bits (90 words) : CIO 200.00 to CIO 289.15 (CIO 200 to CIO 289)	
Work Area (W)	1,600 bits (100 words): W0.00 to W99.15 (W0 to W99)		
Holding Area (H)	800 bits (50 words): H0.00 to H49.15 (H0 to H49) Bits in this area maintain their ON/OFF status when operating mode is changed.		
Auxiliary Area (A)	Read-only: 7,168 bits (448 words) (A0 to A447) Read/write: 4,896 bits (306 words) (A448 to A753)		
Temporary Area (TR)	16 bits: TR0 to TR15		
Timer Area (T)	256 timer numbers (T0 to T255 (separate from counters))		
Counter Area (C)	256 counter numbers (C0 to C255 (separate from timers))		
Data Memory Area (D)	2K words: D0 to D2047 Of these, 1,500 words can be saved to the backup memory (built-in EEPROM) using settings in the Auxiliary Area.		8K words: D0 to D8191 Of these, 7,000 words can be saved to the backup memory (built-in EEPROM) using settings in the Auxiliary Area.
Operating modes		PROGRAM Mode: Program execution is stopped. Preparations can be executed prior to program execution in this mode. MONITOR Mode: Programs are executed. Some operations, such as online editing, and changes to present values in I/O memory, are enabled in this mode. RUN Mode: Programs are executed. This is the normal operating mode.	

1-3-3 Functional Specifications

The following table gives the functional specifications of CP1E CPU Units.

Function			Description		
Cycle time management	Minimum cycle time		Makes the cycle time consistent.		
	Cycle time monitoring		Monitors the cycle time.		
CPU Unit built-in functions	Inputs	High-speed counters inputs	High-speed pulse inputs	High-speed pulses from devices such as a rotary encoder are counted. The counted values are stored in the Auxiliary Area. Interrupt tasks can be executed when target is reached or by range comparison.	
			Input pulse frequency measurement	The frequency of pulses input by the PRV instruction is measured.	
		Interrupt inputs		Relevant interrupt tasks are executed during the cycle when the CPU Unit built-in inputs turn ON or turn OFF.	
		Quick-response inputs		Inputs can be read without being affected by cycle time. Use the quick-response inputs to read signals shorter than the cycle time.	
		Normal inputs	I/O refreshing	Cyclic refreshing	The CPU Unit's built-in I/O are cyclically refreshed.
				Immediate refreshing	I/O refreshing by immediate refreshing instructions.
	Input response times		Input constants can be set for Basic I/O Units. The response time can be increased to reduce the effects of chattering and noise at input contacts. The response time can be decreased to enable detecting shorter input pulses.		
	Outputs	Pulse outputs (Models with transistor outputs only)	Pulse control	A pulse signal is output and positioning or speed control is performed with a servo driver that accepts a pulse input. Continuous mode for speed control or independent mode for position control can be used. There are functions for changing to positioning during speed control and for changing the target value during positioning.	
			Origin positioning	Origin searches and origin returns.	
		PWM outputs (Models with transistor outputs only)		Pulses for which the duty ratio (ratio between ON time and OFF time during one pulse cycle) can be set are output.	
		Normal outputs	Load OFF function	All of the outputs on the CPU Unit's I/O can be turned OFF when an error occurs in RUN or MONITOR mode.	
	Built-in analog	Analog input		Convert analog signal into digital value range from 0 to 6,000.	
Analog output		Convert digital value range from 0 to 6,000 into analog signal.			
Expansion I/O Units and Expansion Units	Functions supported by both Expansion I/O Unit and Expansion Unit	I/O refreshing	Cyclic refreshing	The Expansion I/O Units and Expansion Units are cyclically refreshed.	
			Refreshing by IORF	I/O refreshing by IORF instruction.	
	Load OFF function		All of the outputs on Expansion I/O Units and Expansion Units are turned OFF (0000 hex) when an error occurs in RUN or MONITOR mode.		
	Expansion I/O Units	Input response times		The response time can be increased to reduce the effects of chattering and noise at input contacts. The response time can be decreased to enable detecting shorter input pulses.	
Expansion Units	Unit error detection		Errors in Expansion Units are detected. The CPU Unit is notified that the Expansion Unit stopped due to an error.		
Memory management functions	Holding I/O memory when changing operating modes		The status of I/O memory can be held when the operating mode is changed. The forced-set/reset status can be held when the operating mode is changed.		
	Automatic backup to the backup memory (built-in EEPROM)		Automatic backup of ladder programs and parameter area to the backup memory (built-in EEPROM).		
Communications	Peripheral USB port	Peripheral bus (toolbus)		For communications with programming device (CX-Programmer).	
	Serial port (N/NA-type only)			—	
	Host Link (SYSWAY) communications			Host Link commands can be sent from a PT or a computer to read/write I/O memory, and perform other operations for PLC.	
	No-protocol communications			I/O instructions for communications ports (TXD/RXD instructions) can be used for data transfer with peripheral devices such as bar code readers.	
	NT Link communications			I/O memory in the PLC can be allocated and directly linked to various PT functions, including status control areas, status notification areas, touch switches, lamps, memory tables, and other objects.	
	Serial PLC Links			Up to 10 words of data per Unit can be shared between up to nine CPU Units (one polling unit and eight polled units). * A PT cannot be connected.	
Modbus-RTU Easy Master function			Modbus-RTU commands are sent by the Modbus-RTU Master function. Modbus slaves, such as inverters, can be easily controlled with serial communications.		
Interrupt	Scheduled interrupts		Tasks can be executed at a specified interval (1.0 ms min., Unit: 0.1 ms).		
	Input interrupts		Interrupt tasks are processed when the built-in input turns ON or OFF.		
	High-speed counter interrupts		This function counts input pulses with the CPU Unit's built-in high-speed counter and executes an interrupt task when the count reaches the preset value or falls within a preset range (target value or zone comparison).		

	Function	Description		
Power supply management	Memory protection	Holding Area data, DM Area data, Counter Completion Flags, and Counter Present Values are held even when power is turned OFF. This function is valid only when an optional battery is mounted.		
	Number of power interruptions counter	The number of times power has been interrupted is counted.		
Debugging	Online editing	The program can be changed during operation in MONITOR mode or PROGRAM mode.		
	Force-set/reset	Specified bits can be set or reset.		
	Differentiate monitoring	ON/OFF changes in specified bits can be monitored.		
	Storing the stop position at errors	The location and task number where execution stopped for a program error is recorded.		
	Program check	The programs can be checked for items such as no END instruction and FALS/FAL errors at startup.		
Self-diagnosis and restoration	Error Log	Details and the time of occurrence of error codes predefined by the CPU Unit are stored.		
	CPU error detection	CPU Unit WDT errors are detected.		
	User-defined failure diagnosis	Errors can be generated for user-specified conditions: Non-fatal errors (FAL) and fatal errors (FALS).		
	Load OFF function	The built-in outputs, Expansion I/O Unit outputs, and Expansion Unit outputs are turned OFF.		
	Non-fatal error detection	System FAL error detection (User-defined non-fatal error)	This function generates a non-fatal (FAL) error when the user-defined conditions are met in program.	
		Backup memory error detection	This function detects when data in the backup memory (built-in EEPROM) that stores the ladder program is corrupted.	
		PLC Setup error detection	This function detects setting errors in the PLC Setup.	
		Option Board errors	This function detects when the Option Board is malfunctioning or disconnected.	
		Battery error detection (N/NA□□(S□)-type CPU Units only)	This function detects when the battery voltage is low or the battery is disconnected. * This function is valid only when a battery is mounted and the <i>Do not detect battery error</i> Check Box is cleared in the PLC Setup.	
	Built-in analog errors (NA-type CPU Units only)	This function detects built-in analog I/O errors.		
	Fatal Error Detection	Memory error detection	This function detects errors that occur in memory of the CPU Unit.	
		I/O bus error detection	This function detects errors that occur during data transfer between the CPU Unit and another Unit.	
		Detection of too many I/O points	This function detects when more than the maximum number of CP1W Expansion I/O Units and Expansion Units are connected to the PLC.	
		Program error detection	Program error detection	This function detects when there is an error in the program. See the following for details.
			Instruction processing error detection	This function detects an error when the given data value is invalid when executing an instruction, or execution of instruction between tasks was attempted.
			Indirect DM addressing BCD error	This function detects an error when an indirect DM/EM address in BCD mode is not BCD.
			Illegal area access error detection	This function detects an error when an attempt is made to access an illegal area with an instruction operand.
No END error detection			This function detects an error when there is no END instruction at the end of the program.	
Task error detection			The execution condition for an interrupt task was met but there is no interrupt task with the specified number.	
Differentiation overflow error detection			This function detects an error when too many differentiated instructions are entered or deleted during online editing (131,072 times or more).	
Invalid instruction error detection			This function detects an error when an attempt is made to execute an instruction that is not defined in the system.	
User program area overflow error detection			This function detects an error when instruction data is stored after the last address in user program area.	
Cycle time exceeded error detection	This function monitors the cycle time (10 to 1,000 ms) and stops the operation when the set value is exceeded.			
System FALS error detection (user-defined fatal error)	This function generates a fatal (FALS) error when the user-defined conditions are met in program.			
Maintenance	Automatic online connection via network	This function enables automatically connecting to the PLC online when the CX-Programmer is directly connected by a serial connection (peripheral USB port or serial port).		
Security functions	Read protection using password	This function protects reading and displaying programs using passwords. Read protection: Set a password using the CX-Programmer. * Overwrite protection function not included.		
	Write protection from FINS commands	This function prohibits writing by using FINS commands sent over the network.		

1-4 Difference between E/N/NA□□-type and E/N□□S(1)-type

The differences among functions other than appearances of E/N/NA□□-type CPU Units and E/N□□S(1)-type CPU Units are as follows.

Refer to A-1 Dimensions for the dimensions.

E-type CPU Units

● Difference in Characteristics and Functions

Function	E□□-type	E□□S-type
Analog adjusters	2 adjusters (Setting range: 0 to 255)	None The analog adjuster PV in A642/A643 is fixed on 0000.

● Product Lineup

	Power supply	E□□ CPU Unit				E□□S CPU Unit			
		Relay outputs		Transistor outputs (sinking/sourcing)		Relay Outputs		Transistor outputs (sinking/sourcing)	
		AC	DC	AC	DC	AC	DC	AC	DC
10 I/O points		○	○	○	○	–	–	–	–
14 I/O points		○	–	–	–	○	–	–	–
20 I/O points		○	–	–	–	○	–	–	–
30 I/O points		○	–	–	–	○	–	–	–
40 I/O points		○	–	–	–	○	–	–	–
60 I/O points		–	–	–	–	○	–	–	–

N-type CPU Units

● Difference in Characteristics and Functions

Function	N/NA□□-type	N□□S(1)-type																																																																																								
Analog adjusters	2 adjusters (Setting range: 0 to 255)	None The analog adjuster PV in A642/A643 is fixed on 0000.																																																																																								
Built-in RS-232C port	6 signals are supported: SD, RD, RS, CS, DR and ER. <table border="1"> <thead> <tr> <th>Pin</th> <th>Abbr.</th> <th>Signal</th> <th>Signal direction</th> </tr> </thead> <tbody> <tr><td>1</td><td>FG</td><td>Frame ground</td><td>–</td></tr> <tr><td>2</td><td>SD(TXD)</td><td>Send data</td><td>Outputs</td></tr> <tr><td>3</td><td>RD(RXD)</td><td>Receive data</td><td>Inputs</td></tr> <tr><td>4</td><td>RS(RTS)</td><td>Request to send</td><td>Outputs</td></tr> <tr><td>5</td><td>CS(CTS)</td><td>Clear to send</td><td>Inputs</td></tr> <tr><td>6</td><td>5V</td><td>Power</td><td>–</td></tr> <tr><td>7</td><td>DR(DSR)</td><td>Data set ready</td><td>Inputs</td></tr> <tr><td>8</td><td>ER(DTR)</td><td>Data terminal ready</td><td>Outputs</td></tr> <tr><td>9</td><td>SG(0V)</td><td>Signal ground</td><td>–</td></tr> <tr><td>Connector hood</td><td>FG</td><td>Frame ground</td><td>–</td></tr> </tbody> </table>	Pin	Abbr.	Signal	Signal direction	1	FG	Frame ground	–	2	SD(TXD)	Send data	Outputs	3	RD(RXD)	Receive data	Inputs	4	RS(RTS)	Request to send	Outputs	5	CS(CTS)	Clear to send	Inputs	6	5V	Power	–	7	DR(DSR)	Data set ready	Inputs	8	ER(DTR)	Data terminal ready	Outputs	9	SG(0V)	Signal ground	–	Connector hood	FG	Frame ground	–	4 signals are supported: SD, RD, RS and CS. DR (pin 7) and ER (pin 8) are not supported. <table border="1"> <thead> <tr> <th>Pin</th> <th>Abbr.</th> <th>Signal</th> <th>Signal direction</th> </tr> </thead> <tbody> <tr><td>1</td><td>FG</td><td>Frame ground</td><td>–</td></tr> <tr><td>2</td><td>SD(TXD)</td><td>Send data</td><td>Outputs</td></tr> <tr><td>3</td><td>RD(RXD)</td><td>Receive data</td><td>Inputs</td></tr> <tr><td>4</td><td>RS(RTS)</td><td>Request to send</td><td>Outputs</td></tr> <tr><td>5</td><td>CS(CTS)</td><td>Clear to send</td><td>Inputs</td></tr> <tr><td>6</td><td>5V</td><td>Power</td><td>–</td></tr> <tr><td>7</td><td>NC</td><td>–</td><td>–</td></tr> <tr><td>8</td><td>NC</td><td>–</td><td>–</td></tr> <tr><td>9</td><td>SG(0V)</td><td>Signal ground</td><td>–</td></tr> <tr><td>Connector hood</td><td>FG</td><td>Frame ground</td><td>–</td></tr> </tbody> </table>	Pin	Abbr.	Signal	Signal direction	1	FG	Frame ground	–	2	SD(TXD)	Send data	Outputs	3	RD(RXD)	Receive data	Inputs	4	RS(RTS)	Request to send	Outputs	5	CS(CTS)	Clear to send	Inputs	6	5V	Power	–	7	NC	–	–	8	NC	–	–	9	SG(0V)	Signal ground	–	Connector hood	FG	Frame ground	–
Pin	Abbr.	Signal	Signal direction																																																																																							
1	FG	Frame ground	–																																																																																							
2	SD(TXD)	Send data	Outputs																																																																																							
3	RD(RXD)	Receive data	Inputs																																																																																							
4	RS(RTS)	Request to send	Outputs																																																																																							
5	CS(CTS)	Clear to send	Inputs																																																																																							
6	5V	Power	–																																																																																							
7	DR(DSR)	Data set ready	Inputs																																																																																							
8	ER(DTR)	Data terminal ready	Outputs																																																																																							
9	SG(0V)	Signal ground	–																																																																																							
Connector hood	FG	Frame ground	–																																																																																							
Pin	Abbr.	Signal	Signal direction																																																																																							
1	FG	Frame ground	–																																																																																							
2	SD(TXD)	Send data	Outputs																																																																																							
3	RD(RXD)	Receive data	Inputs																																																																																							
4	RS(RTS)	Request to send	Outputs																																																																																							
5	CS(CTS)	Clear to send	Inputs																																																																																							
6	5V	Power	–																																																																																							
7	NC	–	–																																																																																							
8	NC	–	–																																																																																							
9	SG(0V)	Signal ground	–																																																																																							
Connector hood	FG	Frame ground	–																																																																																							
Option board	1 port (N30/40/60, NA20 CPU Unit only) The following option boards can be mounted. RS-232C Option Board CP1W-CIF01 RS-422A/485 Option Board CP1W-CIF11/12 Ethernet Option Board CP1W-CIF41 Analog Option Board CP1W-ADB21/DAB21V/MAB221	Cannot be mounted There is no slot for an option board.																																																																																								
Built-in RS-485 port	None	1 port (N30/40/60S1 CPU Unit only) With 2-wire connections, it can only communicate in half duplex. Terminating resistance ON/OFF can be set by DIP switch.																																																																																								
COM allocation (Transistor outputs only)	CIO 100.00 and CIO 100.01 correspond with different common terminals. <table border="1"> <tr><td>NC</td><td>00</td><td>01</td><td>02</td></tr> <tr><td>NC</td><td>COM</td><td>COM</td><td>COM</td></tr> <tr><td></td><td></td><td></td><td>03</td></tr> </table> <p>CIO 100.00 and CIO 100.01 are different COM.</p>	NC	00	01	02	NC	COM	COM	COM				03	CIO 100.00 and CIO 100.01 correspond with the same common terminal. <table border="1"> <tr><td>V+</td><td>00</td><td>01</td><td>02</td></tr> <tr><td>V-</td><td>COM(V-)</td><td>COM</td><td>03</td></tr> </table> <p>CIO 100.00 and CIO 100.01 are the same COM.</p>	V+	00	01	02	V-	COM(V-)	COM	03																																																																				
NC	00	01	02																																																																																							
NC	COM	COM	COM																																																																																							
			03																																																																																							
V+	00	01	02																																																																																							
V-	COM(V-)	COM	03																																																																																							

Function	N/NA□□-type	N□□S(1) -type
Power supply for transistor outputs (Transistor outputs only)	Not needed Do not connect an external power supply.	Needed It is necessary to connect a DC24V external power supply when using terminals 00 and 01 on terminal block CIO 100. Do not connect the external power supply to the terminals except 00 and 01 on terminal block CIO 100.
	<p>Wiring Example Sinking outputs</p> <p>Sourcing outputs</p>	<p>Wiring Example Sinking outputs</p> <p>Sourcing outputs</p>

● Product Lineup

	N□□ CPU Unit RS-232C+1 option slot(*)				N□□S CPU Unit Built-in RS-232C				N□□S1 CPU Unit Built-in RS-232C+RS-485				
	Relay outputs		Transistor outputs (sinking/ sourcing)		Relay Outputs		Transistor outputs (sinking/ sourcing)		Relay Outputs		Transistor outputs (sinking/ sourcing)		
	Power supply	AC	DC	AC	DC	AC	DC	AC	DC	AC	DC	AC	DC
10 I/O points		—	—	—	—	—	—	—	—	—	—	—	—
14 I/O points		○	○	○	—	—	—	—	—	—	—	—	—
20 I/O points		○	○	○	—	—	—	—	—	—	—	—	—
30 I/O points		○	○	○	○	—	—	○	○	—	—	○	○
40 I/O points		○	○	○	○	—	—	○	○	—	—	○	○
60 I/O points		○	○	○	○	—	—	○	○	—	—	○	○

* Only N30/40/60 has option slot.

2

Basic System Configuration and Devices

This section describes the basic system configuration and device models of the CP1E.

2-1	Basic System Configuration	2-2
2-1-1	Basic System Configuration Using an E□□(S)-type CPU Unit	2-2
2-1-2	Basic System Configuration Using an N/NA□□(S□)-type CPU Unit	2-3
2-2	CPU Units	2-4
2-2-1	CPU Unit Models	2-4
2-2-2	Optional Products	2-9
2-2-3	Unit Versions of CPU Units	2-11
2-3	Expansion I/O Unit or Expansion Unit	2-13
2-3-1	Expandable CPU Units	2-13
2-3-2	Connection Methods	2-13
2-3-3	Maximum Number of I/O Points for an Expansion I/O Unit or Expansion Unit	2-12
2-3-4	Expansion I/O Units and Expansion Units	2-14
2-3-5	Restrictions on System Configuration	2-16
2-4	Unit Current Consumption and External Power Supply Capacity	2-18
2-4-1	External Power Supply Capacity When Expansion I/O Units or Expansion Units are Connected	2-15
2-4-2	Current Consumption	2-19

2-1 Basic System Configuration

This section describes the system configurations using E□□(S)-type and N/NA□□(S□)-type CP1E CPU Units.

2-1-1 Basic System Configuration Using an E□□(S)-type CPU Unit

The system configuration when using a CP1E E□□(S)-type CPU Unit is shown below.

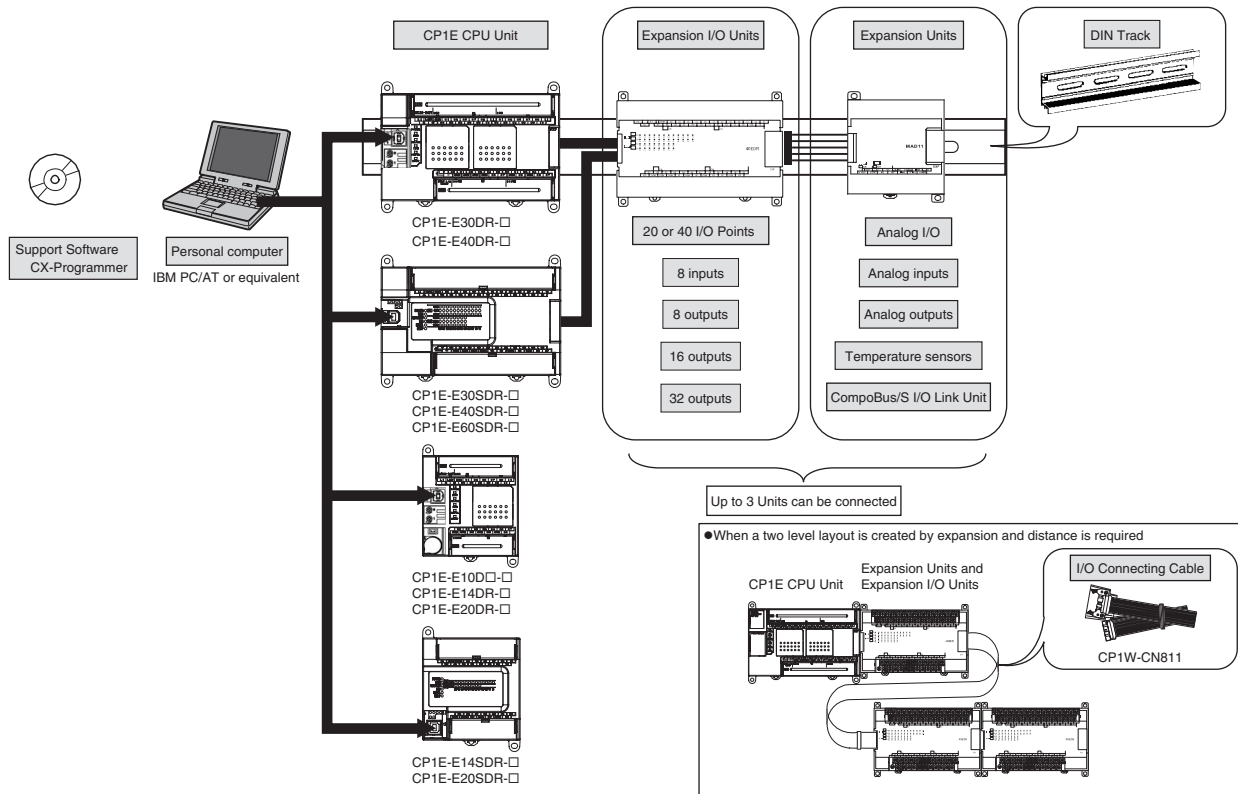

Note In this manual, unless otherwise specified, “CP1W-CIF12” refers to the CP1W-CIF12 and CP1W-CIF12-V1 Option Boards.



Precautions for Correct Use

For CP1E CPU Units, the following I/O memory area will be unstable after a power interruption.

- DM Area (D) (excluding words backed up to the EEPROM using the DM function)
- Holding Area (H)
- Counter Present Values and Completion Flags (C)
- Auxiliary Area related to clock functions(A)

Mount the CP1W-BAT01 Battery (sold separately) to an N/NA□□(S□)-type CPU Unit if data in the above areas need to be retained after a power interruption. A Battery cannot be mounted to an E□□(S)-type CPU Unit.

2-1-2 Basic System Configuration Using an N/NA□□(S□)-type CPU Unit

The system configuration when using a CP1E N/NA□□(S□)-type CPU Unit is shown below.

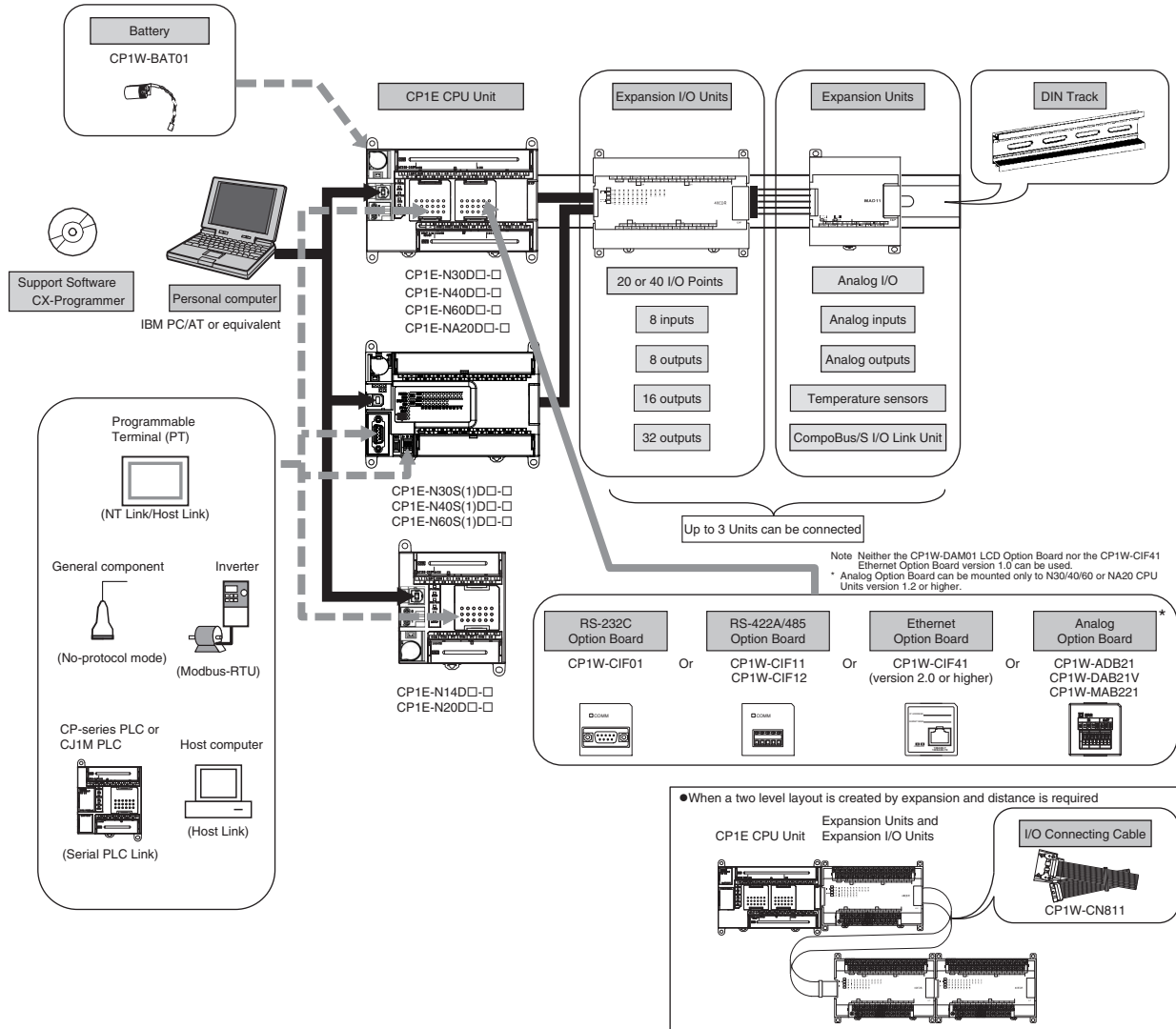

Precautions for Correct Use

For CP1E CPU Units, the following I/O memory area will be unstable after a power interruption.

- DM Area (D) (excluding words backed up to the EEPROM using the DM function)
- Holding Area (H)
- Counter Present Values and Completion Flags (C)
- Auxiliary Area related to clock functions(A)

Mount the CP1W-BAT01 Battery (sold separately) to an N/NA□□(S□)-type CPU Unit if data in the above areas need to be retained after a power interruption. A Battery cannot be mounted to an E□□(S)-type CPU Unit.

2-2 CPU Units

This section describes the models of CP1E CPU Units.

2-2-1 CPU Unit Models

The CP1E CPU Unit model numbers are configured as shown below.

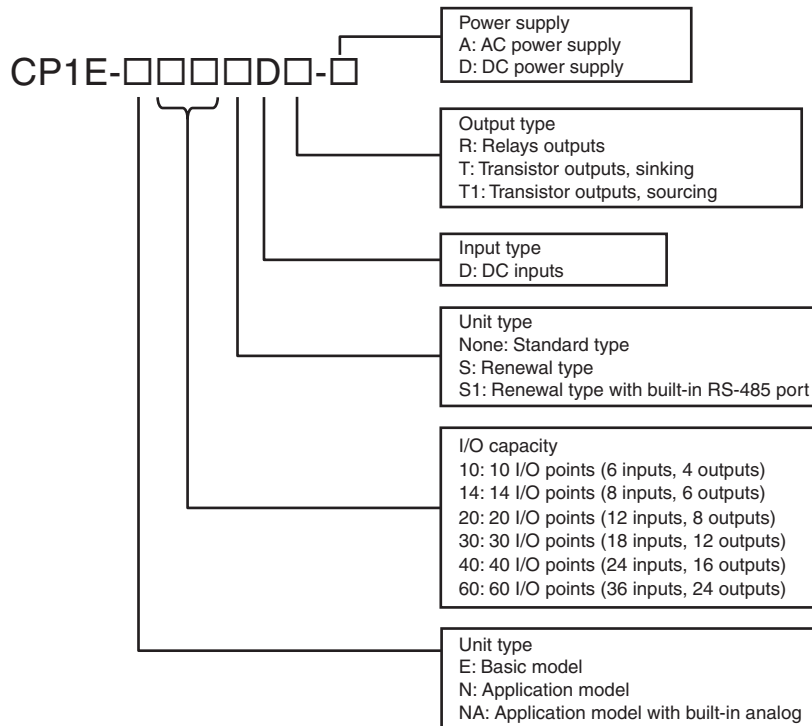

The following is a list of available CP1E CPU Unit models.

E□□S-type CPU Units

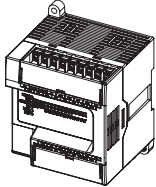
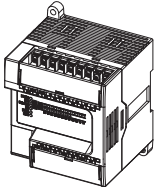
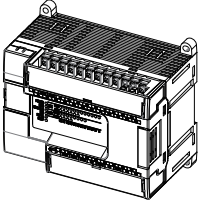
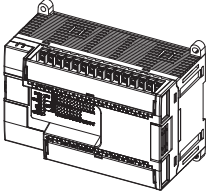
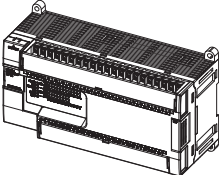
Name and appearance	Model number	Number of built-in I/O points			Power supply specifications	Output type	Program capacity	DM Area capacity	Current consumption		Weight
		Total	Number of inputs	Number of outputs					5 VDC	24 VDC	
CPU Unit with 14 I/O Points 	CP1E-E14SDR-A	14	8	6	AC power supply 100 to 240 VAC	Relays	2K steps	2K words	0.16A	0.07A	350g max.
CPU Unit with 20 I/O Points 	CP1E-E20SDR-A	20	12	8					0.17A	0.08A	360 max.
CPU Unit with 30 I/O Points 	CP1E-E30SDR-A	30	18	12					0.17A	0.07A	590g max.
CPU Unit with 40 I/O Points 	CP1E-E40SDR-A	40	24	16					0.17A	0.09A	650g max.
CPU Unit with 60 I/O Points 	CP1E-E60SDR-A	60	36	24					0.17A	0.13A	840g max.

Note A battery cannot be mounted to an E-type CPU Unit.

E□□-type CPU Units

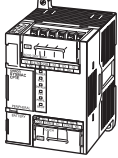
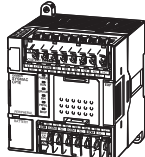
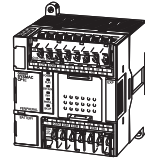
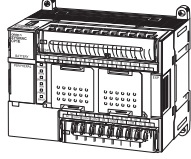
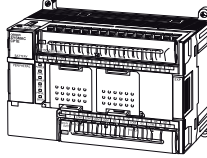
Name and appearance	Model number	Number of built-in I/O points			Power supply specifications	Output type	Program capacity	DM Area capacity	Current consumption		Weight
		Total	Number of inputs	Number of outputs					5 VDC	24 VDC	
	CP1E-E10DR-A	10	6	4	AC power supply 100 to 240 VAC	Relays	2K steps	2K words	0.08A	0.04A	300g max.
	CP1E-E10DT-A					Sinking transistor			0.11A	0.00A	280g max.
	CP1E-E10DT1-A					Sourcing transistor			0.11A	0.00A	280g max.
	CP1E-E10DR-D				DC power supply 24VDC	Relays			0.08A	0.04A	280g max.
	CP1E-E10DT-D					Sinking transistor			0.11A	0.00A	260g max.
	CP1E-E10DT1-D					Sourcing transistor			0.11A	0.00A	260g max.
	CP1E-E14DR-A	14	8	6	AC power supply 100 to 240 VAC	Relays			0.16A	0.07A	350g max.
	CP1E-E20DR-A	20	12	8					0.17A	0.08A	360g max.
	CP1E-E30DR-A	30	18	12					0.17A	0.07A	540g max.
	CP1E-E40DR-A	40	24	16					0.17A	0.09A	650g max.

Note A battery cannot be mounted to an E-type CPU Unit.

N□□S(1)-type CPU Units

Name and appearance	Model number	Number of built-in I/O points			Power supply specifications	Output type	Program capacity	DM Area capacity	Current consumption		Weight
		Total	Number of inputs	Number of outputs					5 VDC	24 VDC	
CPU Unit with 30 I/O Points 	CP1E-N30SDR-A	30	18	12	AC power supply 100 to 240 VAC	Relays	8K steps	8K words	0.21A	0.07A	600g max.
	CP1E-N30SDT-D				DC power supply 24VDC	Sinking transistor			0.27A	0.02A	485g max.
	CP1E-N30SDT1-D					Sourcing transistor					
CPU Unit with 30 I/O Points 	CP1E-N30S1DR-A	30	18	12	AC power supply 100 to 240 VAC	Relays	8K steps	8K words	0.21A	0.07A	600g max.
	CP1E-N30S1DT-D				DC power supply 24VDC	Sinking transistor			0.27A	0.02A	485g max.
	CP1E-N30S1DT1-D					Sourcing transistor					
CPU Unit with 40 I/O Points 	CP1E-N40SDR-A	40	24	16	AC power supply 100 to 240 VAC	Relays	8K steps	8K words	0.21A	0.09A	660g max.
	CP1E-N40SDT-D				DC power supply 24VDC	Sinking transistor			0.31A	0.02A	545g max.
	CP1E-N40SDT1-D					Sourcing transistor					
CPU Unit with 40 I/O Points 	CP1E-N40S1DR-A	40	24	16	AC power supply 100 to 240 VAC	Relays	8K steps	8K words	0.21A	0.09A	660g max.
	CP1E-N40S1DT-D				DC power supply 24VDC	Sinking transistor			0.31A	0.02A	545g max.
	CP1E-N40S1DT1-D					Sourcing transistor					
CPU Unit with 60 I/O Points 	CP1E-N60SDR-A	60	36	24	AC power supply 100 to 240 VAC	Relays	8K steps	8K words	0.21A	0.13A	850g max.
	CP1E-N60SDT-D				DC power supply 24VDC	Sinking transistor			0.31A	0.02A	670g max.
	CP1E-N60SDT1-D					Sourcing transistor					
CPU Unit with 60 I/O Points 	CP1E-N60S1DR-A	60	36	24	AC power supply 100 to 240 VAC	Relays	8K steps	8K words	0.21A	0.13A	850g max.
	CP1E-N60S1DT-D				DC power supply 24VDC	Sinking transistor			0.31A	0.02A	670g max.
	CP1E-N60S1DT1-D					Sourcing transistor					

N□□-type CPU Units





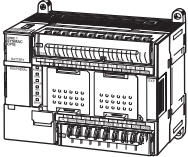

Name and appearance	Model number	Number of built-in I/O points			Power supply specifications	Output type	Program capacity	DM Area capacity	Current consumption		Weight
		Total	Number of inputs	Number of outputs					5 VDC	24 VDC	
	CP1E-N14DR-A	14	8	6	AC power supply 100 to 240 VAC	Relays	8K steps	8K words	0.17A	0.07A	360g max.
	CP1E-N14DT-A					Sinking transistor			0.22A	0.02A	340g max.
	CP1E-N14DT1-A					Sourcing transistor			0.22A	0.02A	340g max.
	CP1E-N14DR-D				DC power supply 24VDC	Relays			0.17A	0.07A	350g max.
	CP1E-N14DT-D					Sinking transistor			0.22A	0.02A	320g max.
	CP1E-N14DT1-D					Sourcing transistor			0.22A	0.02A	320g max.
	CP1E-N20DR-A	20	12	8	AC power supply 100 to 240 VAC	Relays			0.18A	0.08A	370g max.
	CP1E-N20DT-A					Sinking transistors			0.23A	0.02A	340g max.
	CP1E-N20DT1-A					Sourcing transistors			0.23A	0.02A	340g max.
	CP1E-N20DR-D				DC power supply 24VDC	Relays			0.18A	0.08A	360g max.
	CP1E-N20DT-D					Sinking transistors			0.23A	0.02A	330g max.
	CP1E-N20DT1-D					Sourcing transistors			0.23A	0.02A	330g max.
	CP1E-N30DR-A	30	18	12	AC power supply 100 to 240 VAC	Relays			0.21A	0.07A	600g max.
	CP1E-N30DT-A					Sinking transistors			0.27A	0.02A	570g max.
	CP1E-N30DT1-A					Sourcing transistors			0.27A	0.02A	570g max.
	CP1E-N30DR-D				DC power supply 24VDC	Relays			0.21A	0.07A	515g max.
	CP1E-N30DT-D					Sinking transistors			0.27A	0.02A	485g max.
	CP1E-N30DT1-D					Sourcing transistors			0.27A	0.02A	485g max.
	CP1E-N40DR-A	40	24	16	AC power supply 100 to 240 VAC	Relays			0.21A	0.09A	660g max.
	CP1E-N40DT-A					Sinking transistors			0.31A	0.02A	630g max.
	CP1E-N40DT1-A					Sourcing transistors			0.31A	0.02A	630g max.
	CP1E-N40DR-D				DC power supply 24VDC	Relays			0.21A	0.09A	575g max.
	CP1E-N40DT-D					Sinking transistors			0.31A	0.02A	545g max.
	CP1E-N40DT1-D					Sourcing transistors			0.31A	0.02A	545g max.
	CP1E-N60DR-A	60	36	24	AC power supply 100 to 240 VAC	Relays			0.21A	0.13A	850g max.
	CP1E-N60DT-A					Sinking transistor			0.31A	0.02A	790g max.
	CP1E-N60DT1-A					Sourcing transistor			0.31A	0.02A	790g max.
	CP1E-N60DR-D				DC power supply 24VDC	Relays			0.21A	0.13A	720g max.
	CP1E-N60DT-D					Sinking transistor			0.31A	0.02A	670g max.
	CP1E-N60DT1-D					Sourcing transistor			0.31A	0.02A	670g max.



NA-type CPU Units

Name and appearance	Model number	Number of built-in I/O points			Built-in analog		Power supply specifications	Output type	Program capacity	DM Area capacity	Current consumption		Weight
		Total	Number of inputs	Number of outputs	AD	DA					5 VDC	24 VDC	
 CPU Unit with 20 I/O Points and Built-in Analog	CP1E-NA20DR-A	20	12	8	2	1	AC power supply 100 to 240 VAC	Relays	8K steps	8K words	0.18A	0.11A	680g max.
	CP1E-NA20DT-D							Sinking transistor			0.23A	0.09A	500g max.
	CP1E-NA20DT1-D						Sourcing transistor	0.23A			0.09A	500g max.	

2-2-2 Optional Products



Optional Products for CPU Units

Name and appearance	Model number	Applications	Current consumption		Weight
			5 VDC	24 VDC	
 RS-232C Option Board	CP1W-CIF01	Mounted in the option slot of an N30/40/60 or NA20 CPU Unit and can be used as an RS-232C port.	Including in CPU	–	Including in CPU
 Non-isolated RS-422A/485 Option Board	CP1W-CIF11	Mounted in the option slot of an N30/40/60 or NA20 CPU Unit and can be used as an RS-422A/485 port. Maximum transmission distance: 50 m	Including in CPU	–	Including in CPU
 Isolated RS-422A/485 Option Board	CP1W-CIF12	Mounted in the option slot of an N30/40/60 or NA20 CPU Unit and can be used as an RS-422A/485 port. Maximum transmission distance: 500 m	0.075A	–	30g
 Ethernet Option Board	CP1W-CIF41 (version 2.0 or higher)	Mounted in the option slot of an N30/40/60 or NA20 CPU Unit and can be used as an Ethernet port. Maximum transmission distance: 100 m (distance between the hub and the node)	0.130A	–	23g
 Analog Input Option Board	CP1W-ADB21	Mounted in the option slot of an N30/40/60 or NA20 CPU Unit (version 1.2 or higher) and can be used as an analog input module. <ul style="list-style-type: none"> 2 analog inputs 0 to 10 V (Resolution: 1/4000) 0 to 20 mA (Resolution: 1/2000) 	0.020A	–	25g
 Analog Output Option Board	CP1W-DAB21V	Mounted in the option slot of an N30/40/60 or NA20 CPU Unit (version 1.2 or higher) and can be used as an analog output module. <ul style="list-style-type: none"> 2 analog outputs 0 to 10 V (Resolution: 1/4000) 	0.060A	–	25g

Name and appearance	Model number	Applications	Current consumption		Weight
			5 VDC	24 VDC	
Analog Input/Output Option Board 	CP1W-MAB221	Mounted in the option slot of an N30/40/60 or NA20 CPU Unit (version 1.2 or higher) and can be used as an analog input/output module. <ul style="list-style-type: none"> • 2 analog inputs 0 to 10 V (Resolution: 1/4000) 0 to 20 mA (Resolution: 1/2000) • 2 analog outputs 0 to 10 V (Resolution: 1/4000) 	0.080A	–	25g
Battery 	CP1W-BAT01	Mounted in an N/NA□□(S□)-type CPU Unit. Mount the Battery to an N/NA□□(S□)-type CPU Unit if data in the following areas need to be retained after a power interruption. <ul style="list-style-type: none"> • DM Area (D) (excluding words backed up to the EEPROM using the DM backup function) • Holding Area (H) • Counter Present Values and Completion Flags (C) • Auxiliary Area related to clock function (A) A Battery cannot be mounted to an E□□(S)-type CPU Unit.	–	–	–

- Note 1** The CP1W-ME05M Memory Cassette, CP1W-DAM01 LCD Option Board, and CP1W-CIF41 Ethernet Option Board version 1.0 cannot be used with the CP1E CPU Unit.
- 2** Serial Option Boards cannot be used with the N□□S(1)-type CPU Unit.

Installation and Wiring Products

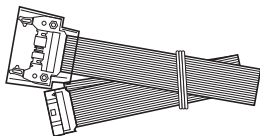
Name and appearance	Model number	Specifications and application
DIN Track 	PFP-50N	Track length: 50 cm, Height: 7.3 mm
	PFP-100N	Track length: 1 m, Height: 7.3 mm
	PFP-100N2	Track length: 1 m, Height: 16 mm
End Plate 	PFP-M	Stopper to prevent Units from moving on the DIN Track.
I/O Connecting Cable 	CP1W-CN811	Length: 800 mm This cable is used if the connecting cable for the Expansion I/O Unit or Expansion Unit is not long enough or for a vertical configuration. Only one I/O Connecting Cable can be used in each PLC.

2-2-3 Unit Versions of CPU Units

Unit Versions

A “unit version” has been introduced to manage CPU Units in the CP Series according to differences in functionality accompanying Unit upgrades.

● Notation of Unit Versions on Products

The unit version is given to the right of the lot number on the nameplate of the products for which unit versions are being managed, as shown below.

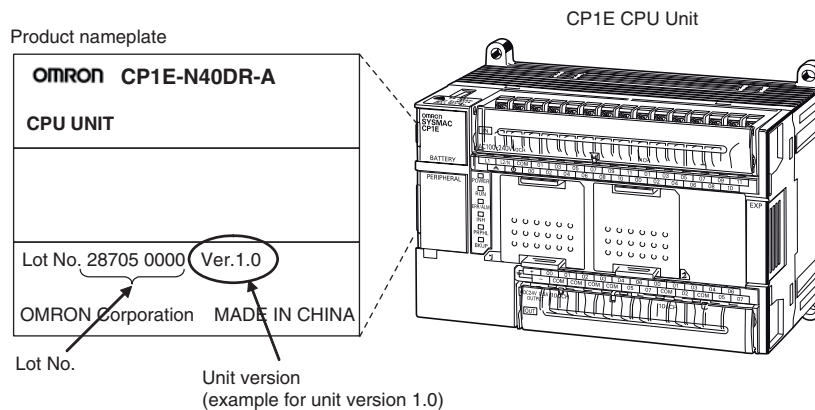

● Confirming Unit Versions with Support Software

CX-Programmer can be used to confirm the unit version of the CP1E CPU Units.

Refer to *4-1 Applicable Programming Devices for CP1E* for details on the CX-Programmer.

The CX-Programmer can be used to confirm the unit version using one of the following methods.

- Using the PLC Information
- Using the Unit Manufacturing Information

Unit Versions

Type	Model numbers	Unit version
CP1E CPU Units	CP1E-E□□SD□-□ CP1E-N□□S(1)D□-□ CP1E-E□□D□-□ CP1E-N□□D□-□ CP1E-NA□□D□-□	Unit version 1.□

Unit Versions and Support Software

The relationship between the unit versions of CP1E CPU Units and versions of Support Software is shown below.

● Relationship between Unit Versions and Support Software

CPU Unit	Functions used	Required Support Software (see note.)							
		CX-Programmer (CX-One)				CX-Programmer Micro PLC Limited Edition			CX-Programmer for CP1E
		Version 8.2 or higher	Version 9.03 or higher	Version 9.42 or higher	Version 9.6 or higher	Version 8.2 or higher	Version 9.03 or higher	Version 9.42 or higher	Version 1.0
CP1E-□20□D□-□ CP1E-□30□D□-□ CP1E-□40□D□-□	Version 1.2 or earlier functions	Yes	Yes	Yes	Yes	Yes	Yes	Yes	Yes
	Support Smart Input function	No	Yes	Yes	Yes	No	Yes	Yes	Yes
	Version 1.3 functions	No	No	No	Yes	No	No	No	No
CP1E-E10D□-□ CP1E-□14□D□-□ CP1E-N60□D□-□ CP1E-NA20D□-□	Version 1.2 or earlier functions	No	Yes	Yes	Yes	Yes	Yes	Yes	No
	Support Smart Input function	No	Yes	Yes	Yes	No	Yes	Yes	Yes
	Version 1.3 functions	No	No	No	Yes	No	No	No	No
CP1E-E60SD□-□	Version 1.2 or earlier functions	No	No	Yes	Yes	No	No	Yes	No
	Support Smart Input function	No	No	Yes	Yes	No	No	Yes	No
	Version 1.3 functions	No	No	No	Yes	No	No	No	No

Note A Programming Console cannot be used.

2-3 Expansion I/O Unit or Expansion Unit

This section describes the connection of Expansion I/O Units or Expansion Units to a CP1E CPU Unit.

2-3-1 Expandable CPU Units

- Expansion I/O Units and Expansion Units cannot be connected to E10/14/20(S) or N14/20 CPU Units.
- A total of up to three Expansion I/O Units and Expansion Units can be connected to an E30/40/60(S), N30/40/60(S□) or NA20 CPU Unit.

● CP1E E10/14/20(S) or N14/20 CPU Unit

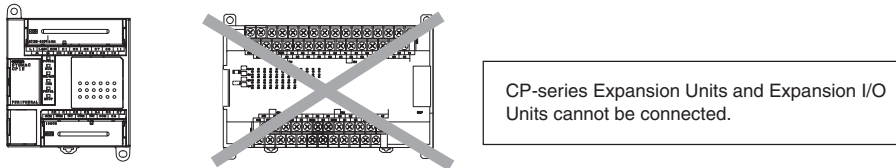

● CP1E E30/40/60(S), N30/40/60(S□) or NA20 CPU Unit

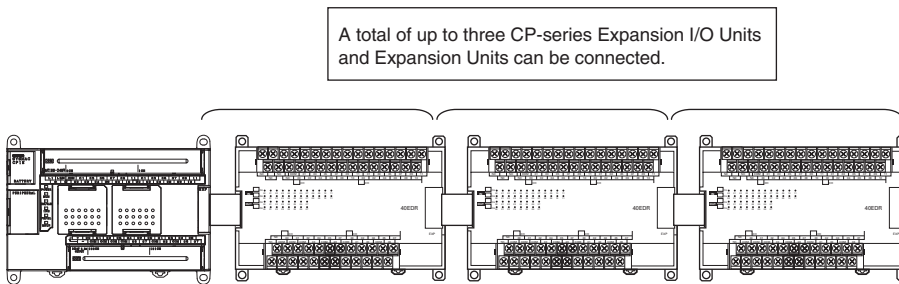

2-3-2 Connection Methods

Connection cables for the Expansion I/O Units and Expansion Units are used to connect the Units. The length can be extended by using a CP1W-CN811 I/O Connecting Cable (length: 800 mm). Leave approximately 10mm of space between the CPU Unit and the Expansion I/O Units or Expansion Units.

2-3-3 Maximum Number of I/O Points for an Expansion I/O Unit or Expansion Unit

CPU Unit	Built-in I/O on CPU Unit			Built-in Analog		Total number of Expansion I/O Units and Expansion Units that can be connected	Number of inputs: 24 Number of outputs: 16 Total number of I/O points when three CP1W-40ED□ Expansion I/O Units are connected		
	Total	Number of inputs	Number of outputs	AD	DA		Total	Number of inputs	Number of outputs
CP1E-E10D□-□	10	6	4	None	None	Not possible.	10	6	4
CP1E-□14D□-□	14	8	6				14	8	6
CP1E-□20D□-□	20	12	8				20	12	8
CP1E-□30D□-□	30	18	12			3 Units maximum	150	90	60
CP1E-□40D□-□	40	24	16				160	96	64
CP1E-□60D□-□	60	36	24				180	108	72
CP1E-NA20D□-□	20	12	8	2	1		140	84	56

2-3-4 Expansion I/O Units and Expansion Units

Expansion I/O Units

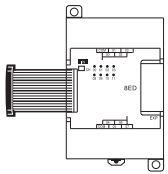
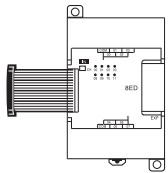
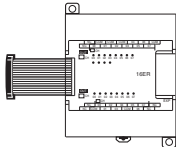
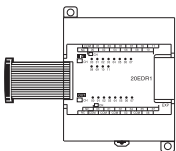
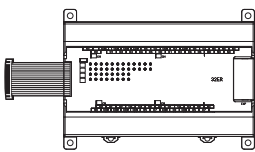
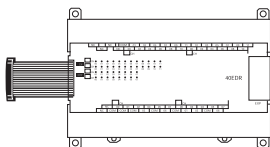
Name and appearance	Model number	Specifications		Current consumption		Weight
		Outputs	Inputs	5V	24V	
8-point Input Unit 	CP1W-8ED	Not provided.	8 inputs, 24 VDC	0.018A	–	200g
8-point Output Unit 	CP1W-8ER	8 relay outputs	Not provided.	0.026A	0.044A	250g
	CP1W-8ET	8 transistor outputs, sinking		0.075A	–	250g
	CP1W-8ET1	8 transistor outputs, sourcing		0.075A	–	250g
16-point Output Unit 	CP1W-16ER	16 relay outputs	Not provided.	0.042A	0.090A	280g
	CP1W-16ET	16 transistor outputs, sinking		0.076A	–	225g
	CP1W-16ET1	16 transistor outputs, sourcing		0.076A	–	225g
20-point I/O Unit 	CP1W-20EDR1	8 relay outputs	12 inputs, 24 VDC	0.103A	0.044A	300g
	CP1W-20EDT	8 transistor outputs, sinking		0.130A	–	300g
	CP1W-20EDT1	8 transistor outputs, sourcing		0.130A	–	300g
32-point Output Unit 	CP1W-32ER	32 relay outputs	Not provided.	0.049A	0.131A	465g
	CP1W-32ET	32 transistor outputs, sinking		0.113A	–	325g
	CP1W-32ET1	32 transistor outputs, sourcing		0.113A	–	325g
40-point I/O Unit 	CP1W-40EDR	16 relay outputs	24 inputs, 24 VDC	0.080A	0.090A	380g
	CP1W-40EDT	16 transistor outputs, sinking		0.160A	–	320g
	CP1W-40EDT1	16 transistor outputs, sourcing		0.160A	–	320g

Expansion Units

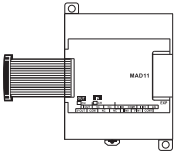
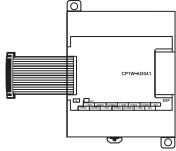
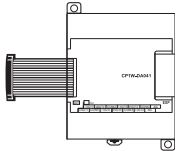
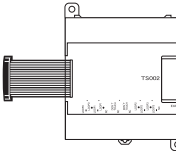
Name and appearance	Model number	Specifications	Current consumption		Weight
			5V	24V	
Analog I/O Unit 	CP1W-MAD11	2 analog inputs 0 to 5 V, 1 to 5 V, 0 to 10 V, -10 to 10 V, 0 to 20 mA, and 4 to 20 mA 1 analog output 1 to 5 V, 0 to 10 V, -10 to 10 V, 0 to 20 mA, 4 to 20 mA Resolution: 1/6,000	0.083A	0.110A	250g
	CP1W-MAD42	4 analog inputs 0 to 5 V, 1 to 5 V, 0 to 10 V, -10 to 10 V, 0 to 20 mA, and 4 to 20 mA 2 analog outputs 1 to 5 V, 0 to 10 V, -10 to 10 V, 0 to 20 mA, 4 to 20 mA Resolution: 1/12,000	0.120A	0.120A	260g
	CP1W-MAD44	4 analog inputs 0 to 5 V, 1 to 5 V, 0 to 10 V, -10 to 10 V, 0 to 20 mA, and 4 to 20 mA 4 analog outputs 1 to 5 V, 0 to 10 V, -10 to 10 V, 0 to 20 mA, 4 to 20 mA Resolution: 1/12,000	0.120A	0.170A	260g
Analog Input Unit 	CP1W-AD041	4 analog inputs 0 to 5 V, 1 to 5 V, 0 to 10 V, -10 to 10 V, 0 to 20 mA, and 4 to 20 mA Resolution: 1/6,000	0.100A	0.090A	200g
	CP1W-AD042	4 analog inputs 0 to 5 V, 1 to 5 V, 0 to 10 V, -10 to 10 V, 0 to 20 mA, and 4 to 20 mA Resolution: 1/12,000	0.100A	0.050A	200g
Analog Output Unit 	CP1W-DA021	2 analog outputs 1 to 5 V, 0 to 10 V, -10 to 10 V, 0 to 20 mA, and 4 to 20 mA Resolution: 1/6,000	0.040A	0.095A	200g
	CP1W-DA041	4 analog outputs 1 to 5 V, 0 to 10 V, -10 to 10 V, 0 to 20 mA, and 4 to 20 mA Resolution: 1/6,000	0.080A	0.124A	200g
	CP1W-DA042	4 analog outputs 1 to 5 V, 0 to 10 V, -10 to 10 V, 0 to 20 mA, and 4 to 20 mA Resolution: 1/12,000	0.070A	0.160A	200g
Temperature Sensor Unit 	CP1W-TS001	Thermocouple inputs K or J, 2 inputs	0.040A	0.059A	250g
	CP1W-TS002	Thermocouple inputs K or J, 4 inputs	0.040A	0.059A	250g
	CP1W-TS003	Thermocouple inputs K or J, 4 inputs or 2 analog inputs 0 to 10 V, 1 to 5 V, 4 to 20 mA Resolution: 1/12,000	0.070A	0.030A	225g
	CP1W-TS101	Platinum resistance thermometer inputs Pt100 or JPt100, 2 inputs	0.054A	0.073A	250g
	CP1W-TS102	Platinum resistance thermometer inputs Pt100 or JPt100, 4 inputs	0.054A	0.073A	250g

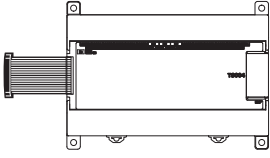
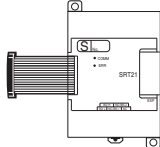
Name and appearance	Model number	Specifications	Current consumption		Weight
			5V	24V	
 <p>Temperature Sensor Unit</p>	CP1W-TS004	Thermocouple inputs K or J, 12 inputs	0.080A	0.050A	380g
 <p>CompoBus/S I/O Link Unit</p>	CP1W-SRT21	Can perform communications as a Compo-Bus/S slave via 8 inputs and 8 outputs.	0.029A	–	200g

2-3-5 Restrictions on System Configuration

The following restrictions apply to the CP-series Expansion Units and CP-series Expansion I/O Units that can be connected to CP1E CPU Units.

Restriction on the Number of Connected Units

A total of up to three Expansion Units and Expansion I/O Units can be connected to an E30/40/60(S), N30/40/60(S□) or NA20 CPU Unit. Expansion Units and Expansion I/O Units cannot be connected to E10/14/20(S) or N14/20 CPU Units.

Each CPU Unit can connect one device to pin 6 (+5V power supply) of the CP1W-CIF01 built-in RS232C port. If one CPU Unit connects two devices, a total of up to two Expansion Units can be connected to the CPU Unit.

Restrictions on External Power Supply Capacity

The following restrictions apply when using the CPU Unit's external power supply.

- **AC-power-supply E30/40/60(S), N30/40/60(S□) or NA20 CPU Unit**

The power supply capacity is restricted for AC-power-supply E30/40/60(S), N30/40/60(S□) or NA20 CPU Units. It may not be possible to use the full 300 mA of the external power supply, though a CPU Unit can connect any CP-series Expansion I/O Unit or Expansion Unit.

The entire 300 mA from the external power supply can be used if Expansion Units and Expansion I/O Units are not connected.

Refer to 2-4-1 *External Power Supply Capacity When Expansion I/O Units or Expansion Units are Connected* for details.

- **AC-power-supply or DC-power-supply E10/14/20(S), N14/20 CPU Unit**

There is no external power supply on AC-power-supply or DC-power-supply E10/14/20(S), N14/20 CPU Units.

Restrictions by ambient temperature

According to the ambient temperature, there are restrictions on power supply voltage and output load current for the DC-power-supply CPU Units.

Refer to *Output Specifications for Relay Outputs* in 3-1-3 *Common I/O Specifications* and in 3-2-4 *I/O Specifications* for details.

Restrictions on the Number of Simultaneously ON Points

Use CP1W-32ER/ET/ET1 32-point Output Units with the number of simultaneously ON less than 24 points (75%).

Mounting Restriction

When connecting CP-series Expansion Units or Expansion I/O Units to a CPU Unit with AC power, provide a space of approximately 10 mm between the CPU Unit and the first Expansion Unit or Expansion I/O Unit.

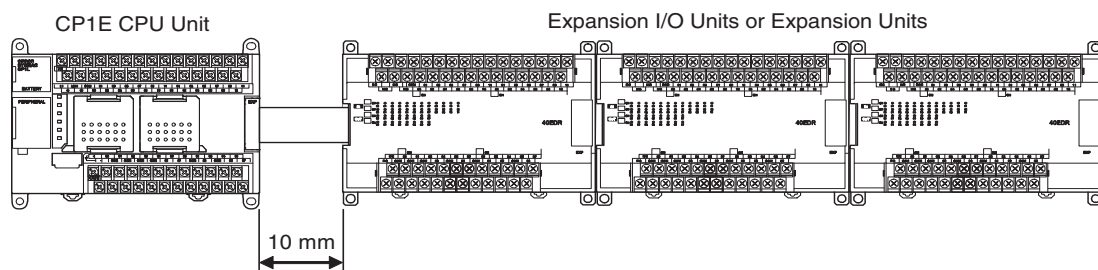

If sufficient space cannot be provided between the CPU Unit and the first Expansion Unit or Expansion I/O Unit, use the PLC in an ambient temperature of 0 to 50°C.

2-4 Unit Current Consumption and External Power Supply Capacity

This section describes the current consumption and external power supply capacity of units used by the CP1E.

2-4-1 External Power Supply Capacity When Expansion I/O Units or Expansion Units are Connected

Power of 24 VDC can be supplied to external devices from E30/40/60(S), N30/40/60(S□) or NA20 CPU Units.

Calculate the usable capacity of external power supply according to the following example.

Calculation Examples of the Capacity Limit of External Power Supply

	CPU Unit	Expansion Units			Other devices using PLC internal power supply	Total	Limit
		1 st unit	2 nd unit	3 rd unit			
	CP1E-□40D□-A	CP1W-DA041	CP1W-DA041	CP1W-DA041	NV3W-MR20L		
5V	0.21A	0.08A	0.08A	0.08A	0.2A	0.65A	≤1.2A
24V	0.09A	0.124A	0.124A	0.124A	–	0.462A	≤0.7A
Power consumption	5 V×0.65 A=3.25 W 24 V×0.462 A=11.088 W					14.258 W	≤18.5 W
Usable capacity of external power supply	18.5 W (Total of usable power consumption) – 14.388 W= 4.162 W 4.162 W/24 V=0.173 A					0.173A	≤0.3A

2-4-2 Current Consumption

● CPU Units

E□□(S)-type CPU Units

I/O capacity	Model number	Current consumption	
		5 VDC	24 VDC
10 I/O points	CP1E-E10DR-A	0.08A	0.04A
	CP1E-E10DT-A	0.11A	0.00A
	CP1E-E10DT1-A	0.11A	0.00A
	CP1E-E10DR-D	0.08A	0.04A
	CP1E-E10DT-D	0.11A	0.00A
	CP1E-E10DT1-D	0.11A	0.00A
14 I/O points	CP1E-E14SDR-A/E14DR-A	0.16A	0.07A
20 I/O points	CP1E-E20SDR-A/E20DR-A	0.17A	0.08A
30 I/O points	CP1E-E30SDR-A/E30DR-A	0.17A	0.07A
40 I/O points	CP1E-E40SDR-A/E40DR-A	0.17A	0.09A
60 I/O points	CP1E-E60SDR-A	0.17A	0.13A

N□□(S□)-type CPU Units

I/O capacity	Model number	Current consumption	
		5 VDC	24 VDC
14 I/O points	CP1E-N14DR-A	0.17A	0.07A
	CP1E-N14DT-A	0.22A	0.02A
	CP1E-N14DT1-A	0.22A	0.02A
	CP1E-N14DR-D	0.17A	0.07A
	CP1E-N14DT-D	0.22A	0.02A
	CP1E-N14DT1-D	0.22A	0.02A
20 I/O points	CP1E-N20DR-A	0.18A	0.08A
	CP1E-N20DT-A	0.23A	0.02A
	CP1E-N20DT1-A	0.23A	0.02A
	CP1E-N20DR-D	0.18A	0.08A
	CP1E-N20DT-D	0.23A	0.02A
	CP1E-N20DT1-D	0.23A	0.02A
30 I/O points	CP1E-N30S1DR-A/N30SDR-A/N30DR-A	0.21A	0.07A
	CP1E-N30DT-A	0.27A	0.02A
	CP1E-N30DT1-A	0.27A	0.02A
	CP1E-N30DR-D	0.21A	0.07A
	CP1E-N30S1DT-D/N30SDT-D/N30DT-D	0.27A	0.02A
	CP1E-N30S1DT1-D/N30SDT1-D/N30DT1-D	0.27A	0.02A
40 I/O points	CP1E-N40S1DR-A/N40SDR-A/N40DR-A	0.21A	0.09A
	CP1E-N40DT-A	0.31A	0.02A
	CP1E-N40DT1-A	0.31A	0.02A
	CP1E-N40DR-D	0.21A	0.09A
	CP1E-N40S1DT-D/N40SDT-D/N40DT-D	0.31A	0.02A
	CP1E-N40S1DT1-D/N40SDT1-D/N40DT1-D	0.31A	0.02A
60 I/O points	CP1E-N60S1DR-A/N60SDR-A/N60DR-A	0.21A	0.13A
	CP1E-N60DT-A	0.31A	0.02A
	CP1E-N60DT1-A	0.31A	0.02A
	CP1E-N60DR-D	0.21A	0.13A
	CP1E-N60S1DT-D/N60SDT-D/N60DT-D	0.31A	0.02A
	CP1E-N60S1DT1-D/N60SDT1-D/N60DT1-D	0.31A	0.02A

NA-type CPU Units

I/O capacity	Model number	Current consumption	
		5 VDC	24 VDC
20 I/O points and built-in analog	CP1E-NA20DR-A	0.18A	0.11A
	CP1E-NA20DT-D	0.23A	0.09A
	CP1E-NA20DT1-D	0.23A	0.09A

Note 1 The current consumption of CP1W-CIF01/11 Option Boards is included in the CPU Unit's current consumption.

2 The current consumption of CP1W-CIF12 Option Boards is 0.075A (5 VDC).

3 The current consumption of CP1W-CIF41 Option Boards version 2.0 is 0.13A (5 VDC).

4 The current consumption of CP1W-ADB21 Option Board is 0.020A (5VDC).

5 The current consumption of CP1W-DAB21V Option Board is 0.060A (5VDC).

6 The current consumption of CP1W-MAB221 Option Board is 0.08A (5VDC).

7 The current consumptions given in the following table must be added to the current consumption of the CPU Unit if an Expansion Unit or Expansion I/O Unit is connected.

● Expansion I/O Units and Expansion Units

Unit name		Model number	Current consumption		
			5 VDC	24 VDC	
Expansion I/O Units	8 inputs	CP1W-8ED	0.018A	–	
		CP1W-8ER	0.026A	0.044A	
	8 outputs	CP1W-8ET	0.075A	–	
		CP1W-8ET1			
		CP1W-8ET1			
	16 outputs	CP1W-16ER	0.042A	0.090A	
		CP1W-16ET	0.076A	–	
		CP1W-16ET1			
	20 I/O points 12 inputs 8 outputs	CP1W-20EDR1	0.103A	0.044A	
		CP1W-20EDT	0.130A	–	
		CP1W-20EDT1			
	32 outputs	CP1W-32ER	0.049A	0.131A	
		CP1W-32ET	0.113A	–	
		CP1W-32ET1			
40 I/O points 24 inputs 16 outputs	CP1W-40EDR	0.080A	0.090A		
	CP1W-40EDT	0.160A	–		
	CP1W-40EDT1				
Expansion Units	Analog Input Unit	4 inputs	CP1W-AD041	0.100A	0.090A
		CP1W-AD042	0.100A	0.050A	
	Analog Output Unit	2 outputs	CP1W-DA021	0.040A	0.095A
		4 outputs	CP1W-DA041	0.080A	0.124A
			CP1W-DA042	0.070A	0.160A
	Analog I/O Unit	Analog inputs: 2 Analog outputs: 1	CP1W-MAD11	0.083A	0.110A
		Analog inputs: 4 Analog outputs: 2	CP1W-MAD42	0.120A	0.120A
		Analog inputs: 4 Analog outputs: 4	CP1W-MAD44	0.120A	0.170A
	Temperature Sensor Units	K or J thermocouples	CP1W-TS001	0.040A	0.059A
			CP1W-TS002		
			CP1W-TS004	0.080A	0.050A
		K, J thermocouples or analog inputs	CP1W-TS003	0.070A	0.030A
		Pt or JPt platinum resistance thermometers	CP1W-TS101	0.054A	0.073A
	CP1W-TS102				
	CompoBus/S I/O Link Unit	8 inputs 8outputs	CP1W-SRT21	0.029A	–

● Other Devices Using PLC Internal Power Supply

Unit name		Model number	Current consumption	
			5 VDC	24 VDC
Conversion Adapter		CJ1W-CIF11	0.04A	–
		NT-AL001	0.15A	–
Programmable Terminal	Backlight Green/Orange/Red	NV3W-MG20L	0.2A	–
	Backlight White/Pink/Red	NV3W-MR20L	0.2A	–

Note CJ1W-CIF11 cannot be connected to the built-in RS-232C port of the CP1E N□□S(1)-type CPU Unit.

3

Part Names and Functions

This section describes the part names, function specifications and terminal arrangements of the CP1E CPU Unit and other Units.

3-1 CPU Units	3-2
3-1-1 E10/14/20(S) or N14/20 CPU Units	3-2
3-1-2 E30/40/60(S), N30/40/60(S□) or NA20 CPU Units	3-7
3-1-3 Common I/O Specifications	3-13
3-1-4 Optional Serial Communications Port for N/NA□□(S□)-type CPU Units ...	3-19
3-1-5 Analog Option Board for N/NA□□-type CPU Units	3-24
3-2 Expansion I/O Units	3-28
3-2-1 Expansion Input Unit	3-28
3-2-2 Expansion Output Units	3-29
3-2-3 Expansion I/O Units	3-31
3-2-4 I/O Specifications	3-33

3-1 CPU Units

This section describes the names of the CPU Unit parts and provides the I/O specifications and terminal arrangements. Refer to *A-1 Dimensions* for the dimensions, *A-2 Wiring Diagrams* for the wiring diagrams.

3-1-1 E10/14/20(S) or N14/20 CPU Units

Part Names and Functions

E-type CPU Unit
CP1E-E10D□-□
CP1E-E14/20DR-A

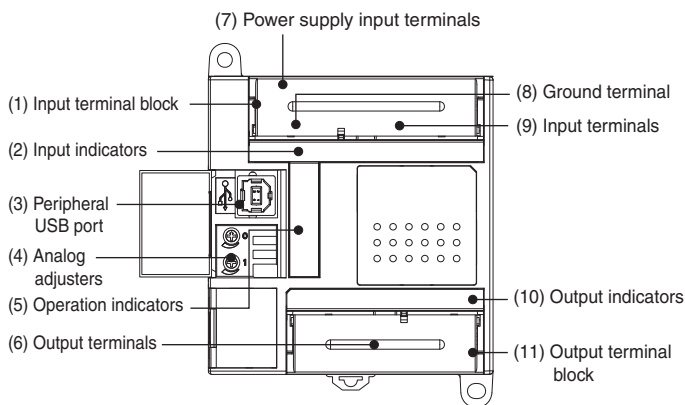

N-type CPU Unit
CP1E-N14/20D□-□

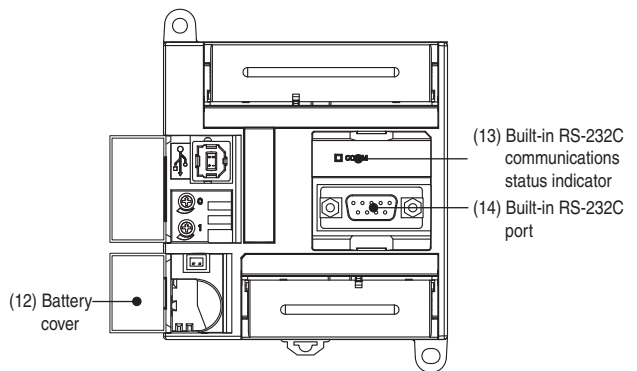

CP1E-E14/20SDR-A

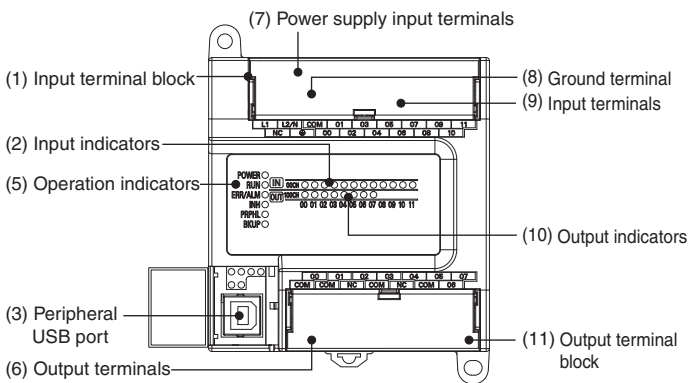

Number	Name	Function
(1)	Input terminal block	This is the terminal block for inputs such as the power supply input and 24 VDC inputs.
(2)	Input indicators (yellow)	Input status is displayed. An indicator will be ON when the input is ON.
(3)	Peripheral USB port	Used to connect to a personal computer for programming and monitoring by the CX-Programmer for CP1E.
(4)	Analog adjusters for E/N□□-type CPU Units	By turning an analog adjuster, it is possible to adjust the value of A642 or A643 within a range of 0 to 255.
(5)	Operation indicators	The CPU Unit's operating status can be confirmed with this indicator. Refer to <i>CPU Unit Status Indicators</i> (Page 3-4).
(6)	Output terminals	Loads such as lamps, contactors, and solenoid valves can be connected.
(7)	Power supply input terminals	Power of 100 to 240 VAC or 24 VDC can be supplied.
(8)	Ground terminal	Protective ground (⊕): To prevent electric shock, ground to 100 Ω or less.
(9)	Input terminals	Input devices such as switches and sensors can be connected.
(10)	Output indicators (yellow)	Output status is displayed. An indicator will be ON when the output is ON.
(11)	Output terminal block	This is the terminal block for outputs such as relay outputs and transistor outputs.
(12)	Battery cover for N□□-type CPU Units	A Battery can be installed by opening the cover. (The Battery is optional).
(13)	Built-in RS-232C communications status indicator	This indicator will be flashing when the built-in RS-232C port is in communication mode.
(14)	Built-in RS-232C port for N□□-type CPU Units	By connecting a PT, the controlled system can be monitored and data can be collected.

CPU Unit Status Indicators

● : Not lit ✕ : Flashing ☒ : Lit

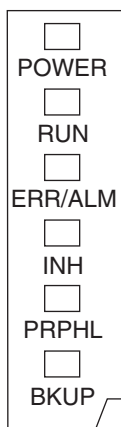

Indicator	Color	Status	Description
POWER	Green	☒ Lit	Power is ON.
		● Not lit	Power is OFF.
RUN	Green	☒ Lit	The CP1E is executing a program in either RUN or MONITOR mode.
		● Not lit	Operation is stopped in PROGRAM mode or due to a fatal error.
ERR/ALM	Red	☒ Lit	A fatal error (including FALS execution) or a hardware error (WDT error) has occurred. CP1E operation will stop and all outputs will be turned OFF.
		✕ Flashing	A non-fatal error has occurred (including FAL execution). CP1E operation will continue.
		● Not lit	Normal
INH	Yellow	☒ Lit	The Output OFF Bit (A500.15) was turned ON. All outputs will be turned OFF.
		● Not lit	Normal
PRPHL	Yellow	✕ Flashing	Communications (either sending or receiving) are in progress through the peripheral USB port.
		● Not lit	Other than the above.
BKUP	Yellow	☒ Lit	The user programs, parameters, or specified DM Area words are being written to the backup memory (built-in EEPROM).
		● Not lit	Other than the above.



Precautions for Safe Use

Do not turn OFF the power supply to the PLC when the BKUP indicator is lit. It indicates that data is being written to the backup memory (built-in EEPROM).

If the power supply is turned OFF while the BKUP indicator is ON, data in the backup memory (built-in EEPROM) may be destroyed.

Terminal Arrangements

● Input Arrangement

AC Power Supply

CP1E-E10D□-A

CIO 0

L1	L2/N	COM	01	03	05
NC		00	02	04	

L1,L2/N : Power supply terminal



: Protective ground terminal

COM : Common terminal

00 to 05 : Input terminal

NC : No connection

CP1E-□14□D□-A

CIO 0

L1	L2/N	COM	01	03	05	07	NC	NC
NC		00	02	04	06	NC	NC	

L1,L2/N : Power supply terminal



: Protective ground terminal

COM : Common terminal

00 to 07 : Input terminal

NC : No connection

CP1E-□20□D□-A

CIO 0

L1	L2/N	COM	01	03	05	07	09	11
NC		00	02	04	06	08	10	

L1,L2/N : Power supply terminal



: Protective ground terminal

COM : Common terminal

00 to 11 : Input terminal

NC : No connection

DC Power Supply

CP1E-E10D□-D

CIO 0

+	-	COM	01	03	05
NC		00	02	04	

+,- : Power supply terminal



: Protective ground terminal

COM : Common terminal

00 to 05 : Input terminal

NC : No connection

CP1E-N14D□-D

CIO 0

+	-	COM	01	03	05	07	NC	NC
NC		00	02	04	06	NC	NC	

+,- : Power supply terminal



: Protective ground terminal

COM : Common terminal

00 to 07 : Input terminal

NC : No connection

CP1E-N20D□-D

CIO 0

+	-	COM	01	03	05	07	09	11
NC		00	02	04	06	08	10	

+,- : Power supply terminal



: Protective ground terminal

COM : Common terminal

00 to 11 : Input terminal

NC : No connection

● **Output Arrangement**

AC Power Supply and DC Power Supply

CP1E-E10D□-□

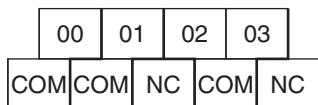

CIO 100

COM : Common terminal
 00 to 03 : Output terminal
 NC : No connection

CP1E-□14□D□-□

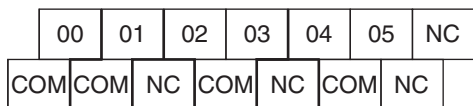

CIO 100

COM : Common terminal
 00 to 05 : Output terminal
 NC : No connection

CP1E-□20□D□-□

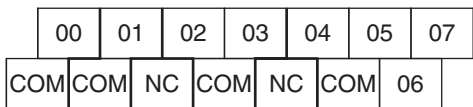

CIO 100

COM : Common terminal
 00 to 07 : Output terminal
 NC : No connection

3-1-2 E30/40/60(S), N30/40/60(S□) or NA20 CPU Units

Part Names and Functions

E-type CPU Unit
CP1E-E30/40DR-A

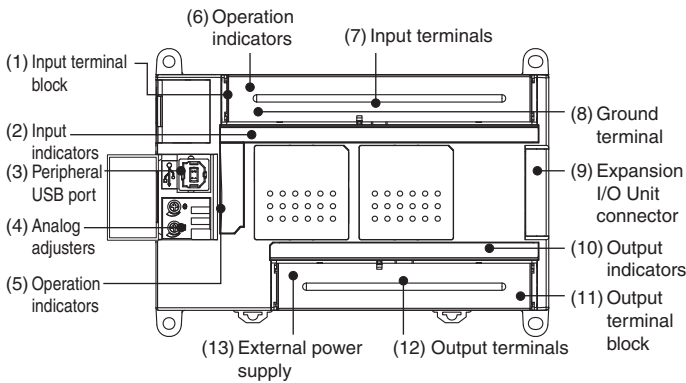

CP1E-E30/40/60SDR-A

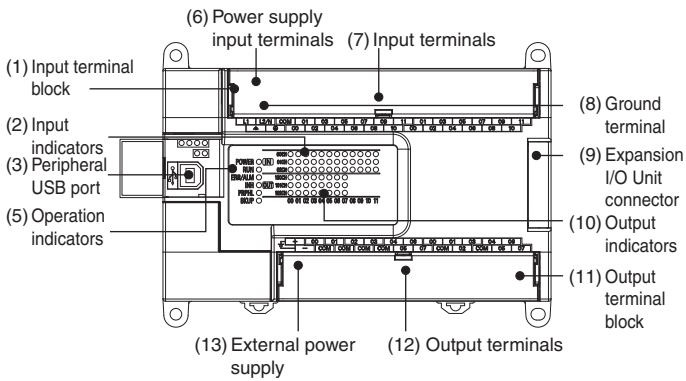

N/NA-type CPU Unit
CP1E-N30/40/60D□-□
CP1E-NA20D□-□

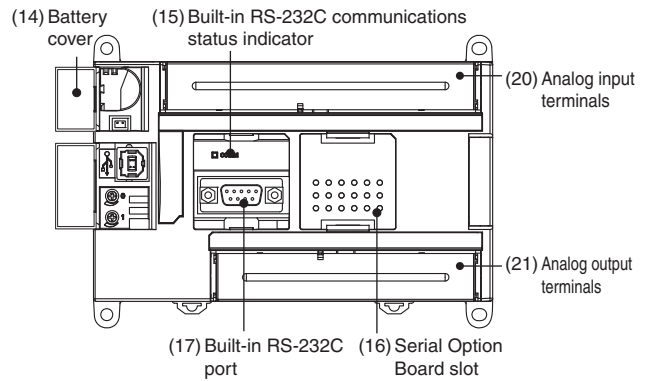

CP1N-N30/40/60S(1)D□-□

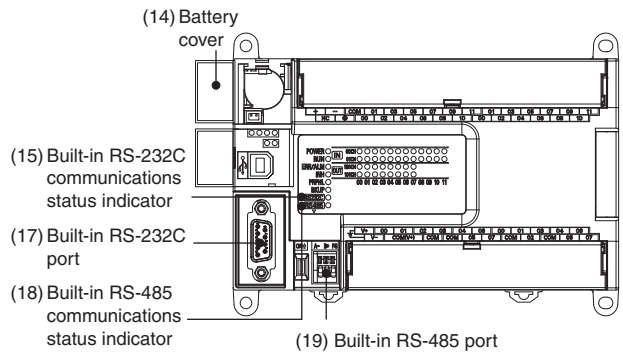

Number	Name	Function
(1)	Input terminal block	This is the terminal block for inputs such as the power supply input and 24-VDC inputs.
(2)	Input indicators (yellow)	Input status is displayed. An indicator will be ON when the input is ON.
(3)	Peripheral USB port	Used to connect to a personal computer for programming and monitoring by the CX-Programmer for CP1E.
(4)	Analog adjusters for N/NA□□-type CPU Units	By turning an analog adjuster, it is possible to adjust the value of A642 or A643 within a range of 0 to 255.
(5)	Operation indicators	The CPU Unit's operating status can be confirmed with this indicator. Refer to <i>CPU Unit Status Indicators</i> (Page 3-9).
(6)	Power supply input terminal	Power of 100 to 240 VAC or 24 VDC can be supplied.
(7)	Input terminals	Input devices such as switches and sensors can be connected.
(8)	Ground terminal	Protective ground (\oplus): To prevent electric shock, ground to 100 Ω or less. Functional ground (\oplus): If noise is a significant source of errors or if electrical shock is a problem, connect to the protective ground terminal and ground both with a ground of 100 Ω or less (AC power supply only).
(9)	Expansion I/O Unit connector	CP-series Expansion I/O Units or Expansion Units such as Analog I/O Units, and Temperature Sensors can be connected. Refer to <i>5-2-4 Connecting Expansion I/O Units and Expansion Units</i> .
(10)	Output indicators (yellow)	Output status is displayed. An indicator will be ON when the output is ON.
(11)	Output terminal block	This is the terminal block for outputs such as relay outputs, transistor outputs, and the external power supply output.
(12)	Output terminals	Loads such as lamps, contactors, and solenoid valves can be connected.
(13)	External power supply terminals	The external supply terminals output up to 300 mA max at 24 VDC. They can be used as a service power supply for input devices (AC power supply only).
(14)	Battery cover for N/NA□□(S□)-type CPU Units	A Battery can be installed by opening the cover. (Battery is optional).
(15)	Built-in RS-232C communications status indicator	This indicator will be flashing when the built-in RS-232C port is in communication mode.
(16)	Option Board slot for N/NA□□-type CPU Units	An Option Board can be connected to the slot. <ul style="list-style-type: none"> • CP1W-CIF01 RS-232C Option Board • CP1W-CIF11 RS-422A/485 Option Board (Maximum transmission distance: 50 m) or CP1W-CIF12 RS-422A/485 Option Board (Maximum transmission distance: 500 m) • CP1W-CIF41 Ethernet Option Board version 2.0 (Maximum transmission distance: 100 m) • CP1W-MAB221/ADB21/DAB21V Analog Option Board (Can be mounted only to N30/40/60 or NA20 CPU Units version 1.2 or higher.)
(17)	Built-in RS-232C port for N/NA□□(S□)-type CPU Units	By connecting a PT, the controlled system can be monitored and data can be collected.
(18)	Built-in RS-485 communications status indicator	This indicator will be flashing when the built-in RS-485 port is in communication mode.
(19)	Built-in RS-485 port for N□□S1-type CPU Units	Communications are possible between an inverter and a PLC by using Modbus-RTU and Serial PLC Links.
(20)	Analog input terminals for NA□□-type CPU Units	Analog output devices such as switches and sensors can be connected.
(21)	Analog output terminals for NA□□-type CPU Units	Analog input device can be connected.

CPU Unit Status Indicators

●: Not lit ◐: Flashing ◑: Lit

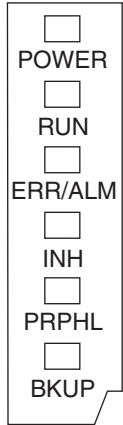

Indicator	Color	Status	Description
POWER	Green	◑ Lit	Power is ON.
		● Not lit	Power is OFF.
RUN	Green	◑ Lit	The CP1E is executing a program in either RUN or MONITOR mode.
		● Not lit	Operation is stopped in PROGRAM mode or due to a fatal error.
ERR/ALM	Red	◑ Lit	A fatal error (including FALS execution) or a hardware error (WDT error) has occurred. CP1E operation will stop and all outputs will be turned OFF.
		◐ Flashing	A non-fatal error has occurred (including FAL execution). CP1E operation will continue.
		● Not lit	Normal
INH	Yellow	◑ Lit	The Output OFF Bit (A500.15) was turned ON. All outputs will be turned OFF.
		● Not lit	Normal
PRPHL	Yellow	◐ Flashing	Communications (either sending or receiving) are in progress through the peripheral USB port.
		● Not lit	Other than the above.
BKUP	Yellow	◑ Lit	The user program, parameters, or specified DM Area words are being written to the backup memory (built-in EEPROM).
		● Not lit	Other than the above.
RS232C	Yellow	◐ Flashing	Communications (either sending or receiving) are in progress through the RS232C.
		● Not lit	Other than the above.
RS485	Yellow	◐ Flashing	Communications (either sending or receiving) are in progress through the RS485.
		● Not lit	Other than the above.



Precautions for Safe Use

Do not turn OFF the power supply to the PLC when the BKUP indicator is lit. It indicates that data is being written to the backup memory (built-in EEPROM).

If the power supply is turned OFF while the BKUP indicator is ON, data in the backup memory (built-in EEPROM) may be destroyed.

Terminal Arrangements

● Input Arrangement

AC Power Supply

CP1E-□30□D□-A

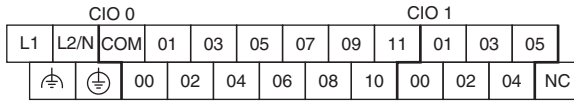

CP1E-□40□D□-A

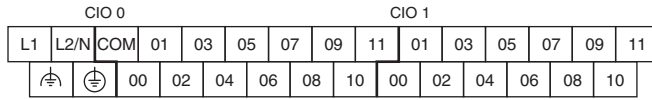

CP1E-□60□D□-A

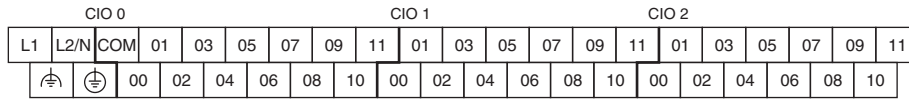

CP1E-NA20DR-A

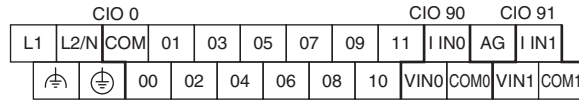

- L1, L2/N : Power supply terminal
- COM : Common terminal
- 00 to 11 : Input terminal
- : Functional ground terminal
- : Protective ground terminal
- NC : No connection
- V IN0, V IN1 : Analog voltage Input
- I IN0, I IN1 : Analog current Input
- COM0, COM1: Common terminal for analog
- AG : Analog 0V

DC Power Supply

CP1E-□30□D□-D

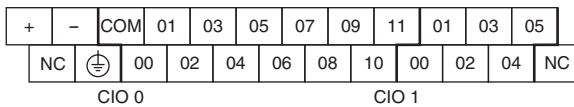

CP1E-□40□D□-D

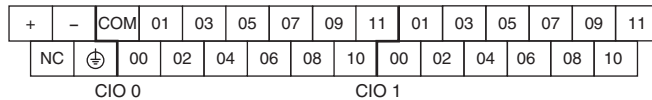

CP1E-□60□D□-D

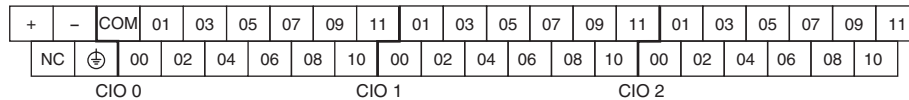

CP1E-NA20D□-D

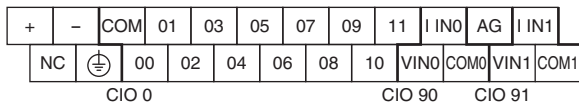

- +, - : Power supply terminal
- COM : Common terminal
- 00 to 11 : Input terminal
- NC : No connection
- : Protective ground terminal
- V IN0, V IN1 : Analog voltage Input
- I IN0, I IN1 : Analog current Input
- COM0, COM1: Common terminal for analog
- AG : Analog 0V

● Output Arrangement

AC Power Supply

CP1E-□30□D□-A

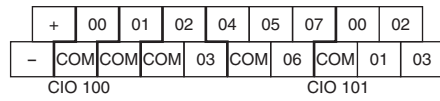

CP1E-□40□D□-A

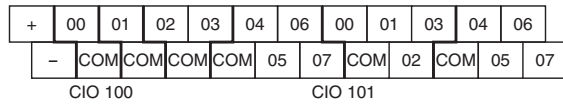

CP1E-□60□D□-A

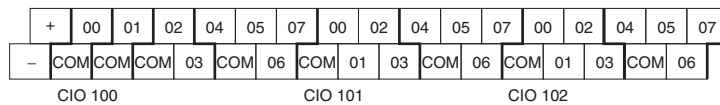

CP1E-NA20DR-A

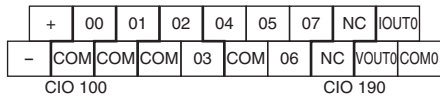

- +, - : External supply terminal
- COM : Common terminal
- 00 to 07 : Output terminal
- VOUT0 : Analog voltage Output
- I OUT0 : Analog current Output
- COM0 : Common terminal for analog

DC Power Supply

CP1E-N30D□-D

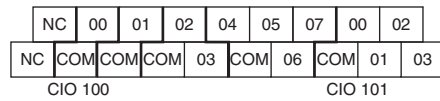

CP1E-N40D□-D

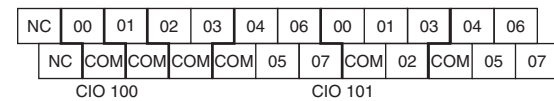

CP1E-N60D□-D

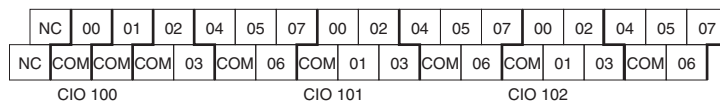

CP1E-NA20D□-D

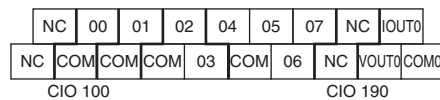

- NC : No connection
- COM : Common terminal
- 00 to 07 : Output terminal
- VOUT0 : Analog voltage Output
- I OUT0 : Analog current Output
- COM0 : Common terminal for analog

CP1E-N30S(1)DT-D

V+	00	01	02	04	05	07	00	02
V-	COM(V-)	COM	03	COM	06	COM	01	03
CIO 100				CIO 101				

Note COM(V-) has been connected with V- in an inner circuit.

- COM : Common terminal
- 00~07 : Output terminal
- V+ : External supply terminal (DC24V)
- V- : External supply terminal (0V)

CP1E-N30S(1)DT1-D

V+	00	01	02	04	05	07	00	02
V-	COM(V+)	COM	03	COM	06	COM	01	03
CIO 100				CIO 101				

Note COM(V+) has been connected with V+ in an inner circuit.

CP1E-N40S(1)DT-D

V+	00	01	02	03	04	06	00	01	03	04	06
V-	COM(V-)	COM	COM	05	07	COM	02	COM	05	07	
CIO 100				CIO 101							

Note COM(V-) has been connected with V- in an inner circuit.

CP1E-N40S(1)DT1-D

V+	00	01	02	03	04	06	00	01	03	04	06
V-	COM(V+)	COM	COM	05	07	COM	02	COM	05	07	
CIO 100				CIO 101							

Note COM(V+) has been connected with V+ in an inner circuit.

CP1E-N60S(1)DT-D

V+	00	01	02	04	05	07	00	02	04	05	07	00	02	04	05	07
V-	COM(V-)	COM	03	COM	06	COM	01	03	COM	06	COM	01	03	COM	06	
CIO 100				CIO 101				CIO 102								

Note COM(V-) has been connected with V- in an inner circuit.

CP1E-N60S(1)DT1-D

V+	00	01	02	04	05	07	00	02	04	05	07	00	02	04	05	07
V-	COM(V+)	COM	03	COM	06	COM	01	03	COM	06	COM	01	03	COM	06	
CIO 100				CIO 101				CIO 102								

Note COM(V+) has been connected with V+ in an inner circuit.

3-1-3 Common I/O Specifications

The following table gives the specifications that apply to the built-in I/O on a CP1E CPU Unit.

Specifications

Item	Specification										
Input type	High-speed counter inputs or normal inputs	High-speed counter inputs, interrupt inputs, quick-response inputs or normal inputs	Normal inputs								
Input bits	CIO 0.00 to CIO 0.01	CIO 0.02 to CIO 0.07*1	CIO 0.08 to CIO 0.11, CIO 1.00 to CIO 1.11 and CIO 2.00 to CIO 2.11 *1								
Input voltage	24 VDC, +10%, -15%										
Applicable sensors	2-wire and 3-wire sensors										
Input impedance	3.3 kΩ	3.3 kΩ	4.8 kΩ								
Input current	7.5 mA typical	7.5 mA typical	5 mA typical								
ON voltage/current	3 mA min. at 17.0 VDC min.	3 mA min. at 17.0 VDC min.	3 mA min. at 14.4 min.								
OFF voltage/current	1 mA max. at 5.0 VDC max.	1 mA max. at 5.0 VDC max.	1 mA max. at 5.0 VDC max.								
ON response time*2	E□□(S)-type CPU Unit: 50 μs min. N/NA□□(S□)-type CPU Unit: 2.5 μs min.	50 μs max.	1 ms max.								
OFF response time*2	E□□(S)-type CPU Unit: 50 μs min. N/NA□□(S□)-type CPU Unit: 2.5 μs min.	50 μs max.	1 ms max.								
Circuit configuration	<table border="1"> <thead> <tr> <th>E□□(S)-type CPU Unit</th> <th>N/NA□□(S□)-type CPU Unit</th> </tr> </thead> <tbody> <tr> <td> Inputs: CIO 0.00 to CIO 0.07 </td> <td> Inputs: CIO 0.00, CIO 0.01 </td> </tr> <tr> <td> Inputs: CIO 0.08 to CIO 0.11 and CIO 1.00 to CIO 1.11 </td> <td> Inputs: CIO 0.02 to CIO 0.07 </td> </tr> <tr> <td></td> <td> Inputs: CIO 0.08 to CIO 0.11, CIO 1.00 to CIO 1.11 and CIO 2.00 to CIO 2.11 </td> </tr> </tbody> </table>			E□□(S)-type CPU Unit	N/NA□□(S□)-type CPU Unit	Inputs: CIO 0.00 to CIO 0.07 	Inputs: CIO 0.00, CIO 0.01 	Inputs: CIO 0.08 to CIO 0.11 and CIO 1.00 to CIO 1.11 	Inputs: CIO 0.02 to CIO 0.07 		Inputs: CIO 0.08 to CIO 0.11, CIO 1.00 to CIO 1.11 and CIO 2.00 to CIO 2.11
E□□(S)-type CPU Unit	N/NA□□(S□)-type CPU Unit										
Inputs: CIO 0.00 to CIO 0.07 	Inputs: CIO 0.00, CIO 0.01 										
Inputs: CIO 0.08 to CIO 0.11 and CIO 1.00 to CIO 1.11 	Inputs: CIO 0.02 to CIO 0.07 										
	Inputs: CIO 0.08 to CIO 0.11, CIO 1.00 to CIO 1.11 and CIO 2.00 to CIO 2.11 										

- *1 The bits that can be used depend on the model of CPU Unit.
- *2 The response time is the delay caused by hardware. The delay set in the PLC Setup (0 to 32 ms, default: 8 ms) for a normal input must be added to this value.

Pulse plus direction input mode,
Increment mode
Up/down input mode

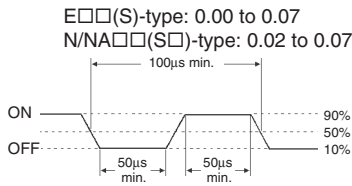
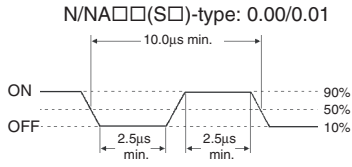

Differential phase mode

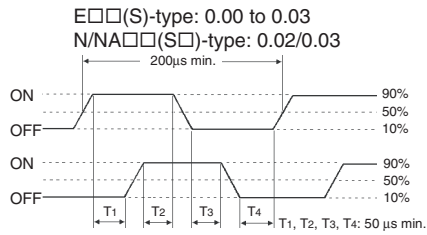
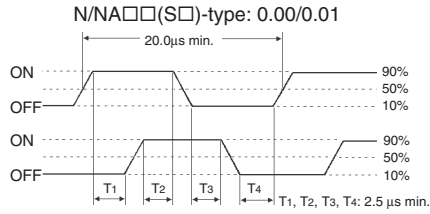

Output Specifications for Relay Outputs

CP1E-□□□□DR-□

Item		Specification
Maximum switching capacity		2 A 250 VAC ($\cos\phi=1$) 2 A 24 VDC (4 A/common)
Minimum switching capacity		10 mA 5 VDC
Service life of relay	Electrical	Resistive load 200,000 operations (24 VDC)
		Inductive load 70,000 operations (250 VAC, $\cos\phi = 0.4$)
	Mechanical	20,000,000 operations
ON response time		15 ms max.
OFF response time		15 ms max.
Circuit configuration		

● **Estimating the Service Life of Relays**

Under normal conditions, the service life of output contacts is as shown above. The service life of relays is as shown in the following diagram as a guideline.

CP1E-□□□□DR-□

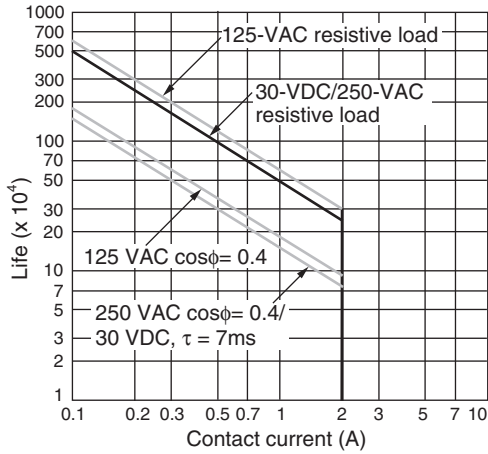

● **Relationship between Continuous Simultaneous ON Rate and Ambient Temperature**

There are restrictions on the power supply voltage and output load current imposed by the ambient temperature. Make sure that the power supply voltage and output load current are within the following ranges.

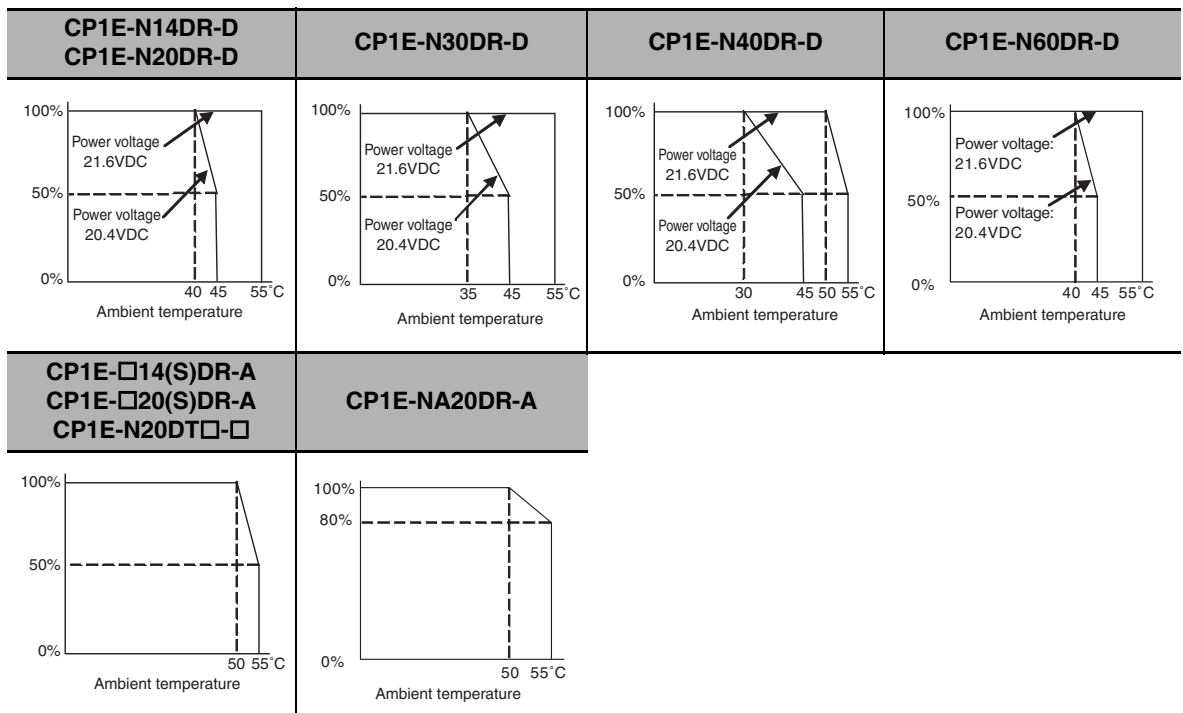

Note The above restrictions apply to the relay output load current from the CPU Unit even if Expansion I/O Units are not connected.

Output Specifications for Transistor Outputs (Sinking or Sourcing)

CP1E-N14/20/30/40/60□DT(1)-□, CP1E-E10DT(1)-□, CP1E-NA20DT(1)-□

● Normal Outputs

Item	Specification	
	N/NA□□(S□)-type: CIO 100.00 and CIO 100.01	N/NA□□(S□)-type: CIO 100.02 to CIO 102.07 *2 E10-type: CIO 100.00 to CIO 100.03
Maximum switching capacity	0.3 A/output, 0.9 A/common*1 4.5 to 30 VDC CP1E-E10DT□-□: 0.9 A/Unit CP1E-N40(S□)D□-□: 3.6 A/Unit CP1E-N14DT□-□: 1.5 A/Unit CP1E-N60(S□)D□-□: 5.4 A/Unit CP1E-N20DT□-□: 1.8 A/Unit CP1E-NA20DT□-□: 1.8 A/Unit CP1E-N30(S□)D□-□: 2.7 A/Unit	
Minimum switching capacity	1 mA 4.5 to 30 VDC	
Leakage current	0.1mA max.	
Residual voltage	0.6 V max.	1.5V max.
ON response time	0.1 ms max.	0.1 ms max.
OFF response time	0.1 ms max.	1 ms max.
Fuse	Not provided.	
External power supply	20.4 to 26.4VDC 30mA max. (N/NA□□-type is not needed)	Not needed
Circuit configuration	<p>• N□□S(1)-type CPU Unit</p> <p>Sinking output model</p> <p>Sourcing output model</p> <p>• N/NA□□-type CPU Unit</p> <p>Sinking output model</p> <p>Sourcing output model</p>	

*1 Also do not exceed 0.9 A for the total of CIO 100.00 to CIO 100.03, which are different common.

*2 The bits that can be used depend on the model of CPU Unit.

 **Precautions for Correct Use**

Do not connect a load to an output terminal or apply a voltage in excess of the maximum switching capacity.

● **Pulse Outputs (CIO 100.00 and CIO 100.01)**

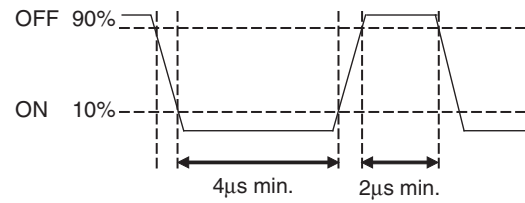
Item	Specification
Maximum switching capacity	100 mA 4.5 to 26.4 VDC
Minimum switching capacity	7 mA 4.5 to 26.4 VDC
Maximum output frequency	100 kHz
Output waveform	 <p>The OFF and ON refer to the output transistor. The output transistor is ON at level "L".</p>

 **Additional Information**

- The load for the above values is assumed to be the resistive load, and does not take into account the impedance for the connecting cable to the load.
- Due to distortions in pulse waveforms resulting from connecting cable impedance, the pulse widths in actual operation may be smaller than the values shown above.

● **PWM Output (CIO 100.01)**

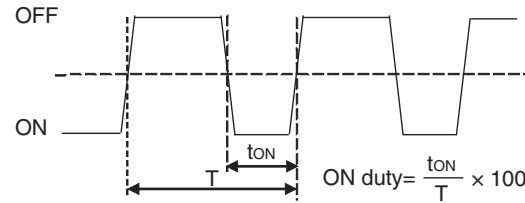
Item	Specification
Maximum switching capacity	30 mA 4.5 to 26.4 VDC
Maximum output frequency	32 kHz
PWM output accuracy	For ON duty +1%, -0%: 10 kHz output For ON duty +5%, -0%: 0 to 32 kHz output
Output waveform	 <p>The OFF and ON refer to the output transistor. The output transistor is ON at level "L".</p>

Analog I/O (NA-type CPU Units)

The NA-type CPU Units of the CP1E CPU Units are equipped with 2 built-in analog inputs and 1 built-in analog output.

● Analog Input Specifications

Item		Voltage input	Current input
Number of inputs		2 inputs (Allocated 2 words: CIO 90 to CIO 91.)	
Input signal range		0 to 5 V, 1 to 5 V, 0 to 10 V, or -10 to 10 V	0 to 20 mA or 4 to 20 mA
Max. rated input		±15 V	±30 mA
External input impedance		1 MΩ min.	Approx. 250Ω
Resolution		1/6000	
Overall accuracy	At 25°C	±0.3% full scale	±0.4% full scale
	0 to 55°C	±0.6% full scale	±0.8% full scale
A/D conversion data	-10 to 10 V	F448 to 0BB8 hex FS	
	Other ranges	0000 to 1770 hex FS	
Averaging function		Supported (Set for individual inputs in the PLC Setup.)	
Open-circuit detection function		Supported (Value when disconnected: 8000 hex)	

● Analog Output Specifications

Item		Voltage output	Current output
Number of outputs		1 output (Allocated 1 word: CIO 190.)	
Output signal range		0 to 5 V, 1 to 5 V, 0 to 10 V, or -10 to 10 V	0 to 20 mA* or 4 to 20 mA
Allowable external output load resistance		1 kΩ min.	600Ω max.
External input impedance		0.5Ω max.	---
Resolution		1/6000	
Overall accuracy	At 25°C	±0.4% full scale	
	0 to 55°C	±0.8% full scale	
D/A conversion data	-10 to 10 V	F448 to 0BB8 hex FS	
	Other ranges	0000 to 1770 hex FS	

* When the analog current output is 0 to 20mA, the accuracy cannot be ensured at 0.2mA or less.

● Shared I/O Specifications

Item	Specification
Conversion time	2 ms/point (6 ms total for 2 analog inputs and 1 analog output.)
Isolation method	Photocoupler isolation between analog I/O terminals and internal circuits. No isolation between analog I/O signals.

3-1-4 Optional Serial Communications Port for N/NA□□(S□)-type CPU Units

The Serial Communication Port can be used for a CP1E N/NA□□(S□)-type CPU Unit.

N/NA□□-type CPU Units

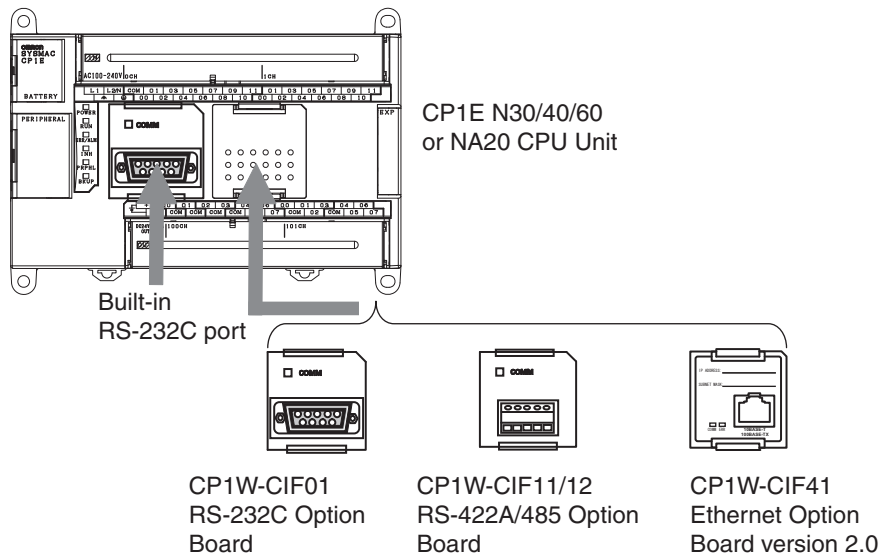

Optional Serial Communication Board

Model numbers	Port	Maximum transmission distance	Connection method
CP1W-CIF01	One RS-232C port	15m	Connector (D-sub, 9 pin female)
CP1W-CIF11	One RS-422A/485 port (not isolated)	50m	Terminal block (using ferrules)
CP1W-CIF12	One RS-422A/485 port (isolated)	500m	Terminal block (using ferrules)
CP1W-CIF41	One Ethernet port	100m	Connector (RJ45, 8 pin modular)

● How to mount an Option Board

When mounting an Option Board, first remove the slot cover.

Grasp both of the cover's up/down lock levers at the same time to unlock the cover, and then pull the cover out.

Then to mount the Option Board, check the alignment and firmly press it in until it snaps into place.



Precautions for Correct Use

Always turn OFF the power supply to the PLC before mounting or removing an Option Board.

N/NA□□S(1) -type CPU Units

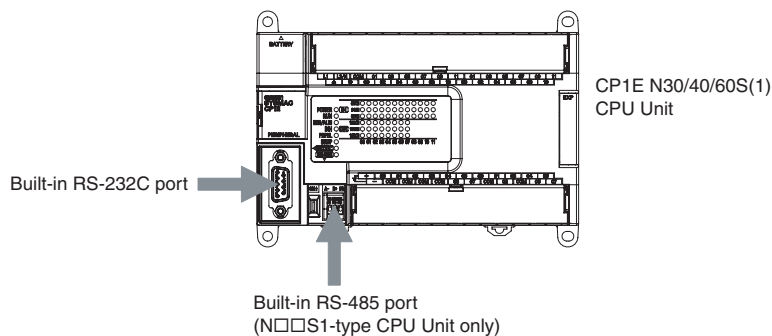

Built-in RS-232C Port and CP1W-CIF01 RS-232C Option Board

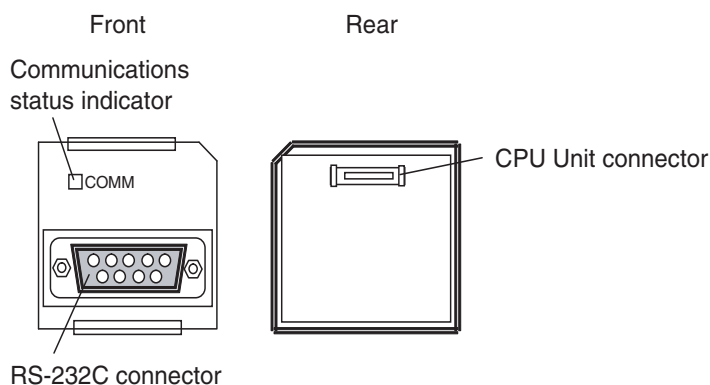

● RS-232C Connector

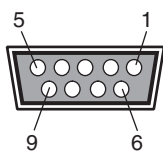

Pin	Abbr.		Signal	Signal direction
	N□□-type built-in RS-232C port CP1W-CIF01	N□□S(1)-type built-in RS-232C port		
1	FG		Frame ground	–
2	SD(TXD)		Send data	Outputs
3	RD(RXD)		Receive data	Inputs
4	RS(RTS)		Request to send	Outputs
5	CS(CTS)		Clear to send	Inputs
6	5V		Power	–
7	DR(DSR)	NC*	Data set ready	Inputs
8	ER(DTR)	NC*	Data terminal ready	Outputs
9	SG(0V)		Signal ground	–
Connector hood	FG		Frame ground	–

* DR and ER signals are not supported by the built-in RS-232C port on the N□□S-type CPU Unit.

Note 1 The following devices can be connected to pin 6 (+5V) on the built-in RS-232C port on the CPU Unit or the RS-232C Option Board (CP1W-CIF01) mounted to the CPU Unit. Do not connect pin 6 to any other device.

- RS-422A CJ1W-CIF11 Conversion Adapter
- RS-232C / RS-422A NT-AL001 Conversion Adapter
- NV3W-M□20L Programmable Terminal

2 CJ1W-CIF11 cannot be connected to the built-in RS-232C port of the CP1E N□□S(1)-type CPU Unit.

Built-in RS-485 Port (2-wire) for N30/40/60S1 CPU Units

● RS-485 Terminal Block

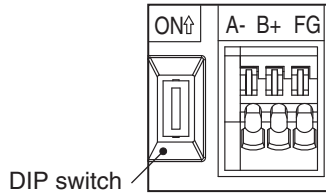

● DIP switch for terminating resistance settings

Setting		
ON	ON (both ends)	Terminating resistance selection
OFF	OFF	Resistance value: 220Ω typical

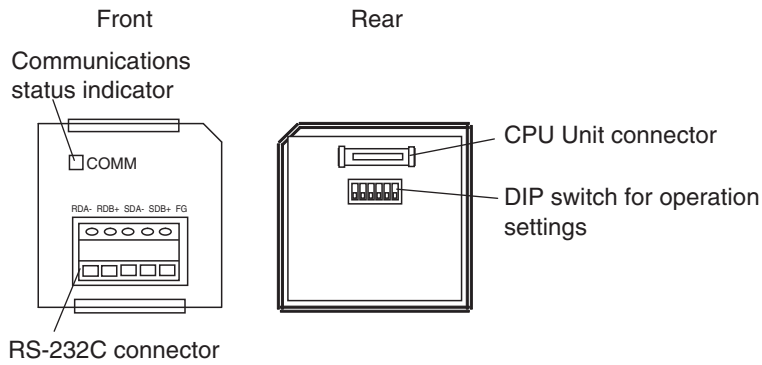

CP1W-CIF11 or CP1W-CIF12 RS-422A/485 Option Board

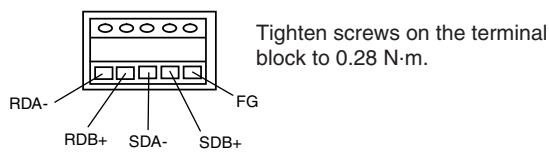

● RS-422A/485 Terminal Block

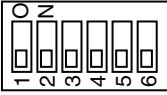
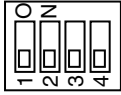

● **DIP switch for operation settings**

CP1W-CIF11/12	Pin	CP1W-CIF12-V1	Pin	Setting		
				ON	OFF	Setting
	1		1	ON	ON (both ends)	Terminating resistance selection Resistance value:220Ω typical
				OFF	OFF	
	2		2	ON	2-wire connections	2-wire or 4-wire selection*1
				OFF	4-wire connections	
	3		3	ON	2-wire connections	2-wire or 4-wire selection*1
				OFF	4-wire connections	
4	4	-	-	Not used.		
5	1		1	ON	RS control enabled	RS control selection for RD*2
				OFF	RS control disabled (Data always received.)	
	2		2	ON	RS control enabled	RS control selection for SD*3
				OFF	RS control disabled (Data always sent.)	

*1 Set both pins 2 and 3 to either ON (2-wire) or OFF (4-wire).

*2 To disable the echo-back function, set pin 5 to ON (RS control enabled).

*3 When connecting to a device on the N side in a 1: N connection with the 4-wire method, set pin 6 to ON (RS control enabled).
Also, when connecting by the 2-wire method, set pin 6 to ON (RS control enabled).

CP1W-CIF41 Ethernet Option Board

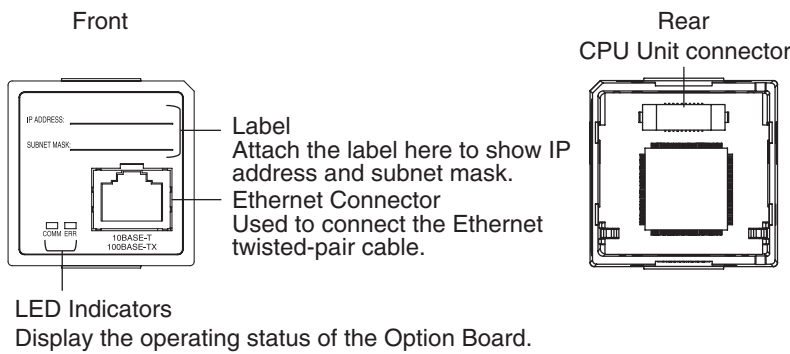

● **LED Indicators**

Indicator	Color	Status	Meaning
COMM	Yellow	Not lit	Not sending or receiving data.
		Flashing	Sending or receiving data.
ERR	Red	Not lit	Unit normal.
		Lit	An fatal error has occurred at the Unit.
		Flashing	An no-fatal error has occurred at the unit.

● **Ethernet Connectors**

The following standards and specifications apply to the connectors for the Ethernet twisted-pair cable.

Electrical specifications: Conforming to IEEE802.3 standards

Connector structure: RJ45 8-pin Modular Connector (conforming to ISO8877)

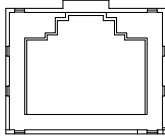

Connector Pin	Signal Name	Abbr.	Signal Direction
1	Transmission data +	TD+	Output
2	Transmission data -	TD-	Output
3	Reception data +	RD+	Input
4	Not used	---	---
5	Not used	---	---
6	Reception data -	RD-	Input
7	Not used	---	---
8	Not used	---	---
Hood	Frame ground	FG	---



Precautions for Correct Use

Connecting the Cable

- Turn OFF the PLC's power supply before connection or disconnecting twisted-pair cable.
- Allow enough space for the bending radius of the twisted-pair cable.

3-1-5 Analog Option Board for N/NA□□-type CPU Units

The Analog Option Board can be used for a CP1E N30/40/60 or NA20 CPU Unit.

N/NA□□-type CPU Units

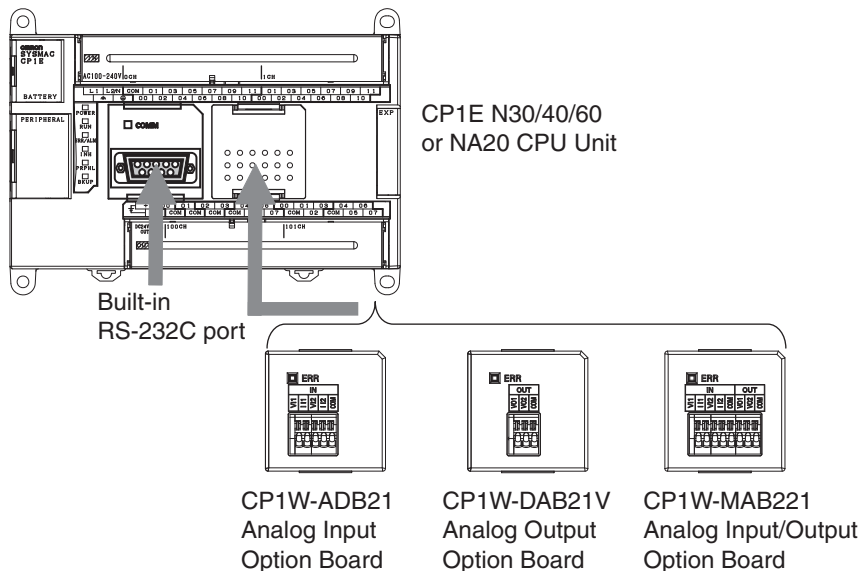

Analog Option Board

CP1 series analog option board units are non-isolated analog units which allow you to easily realize analog input/output function for CP1E N30/40/60 or NA20 CPU Unit (unit version 1.2 or higher).

Analog Option Board		Voltage Input 0V~10V (Resolution: 1/4000)	Current Input 0mA~20mA (Resolution: 1/2000)	Voltage Output 0V~10V (Resolution: 1/4000)
Analog I/O Option Board	CP1W-MAB221	2CH		2CH
Analog Input Option Board	CP1W-ADB21	2CH		---
Analog Output Option Board	CP1W-DAB21V	---		2CH

● How to mount an Analog Option Board

Press the up/down lock-levers on both sides of the Option Board slot cover at the same time to unlock the cover, and then pull the cover out.

Check the alignment to make the corner cut of the Analog Option Board fit in the Option Board slot, and firmly press the Analog Option Board in until it snaps into place.



Precautions for Correct Use

Always turn OFF the power supply to the CPU Unit and wait until all the operation indicators go out before installing or removing the analog option board.

Not doing so may result in an unexpected operation.

Analog Input Option Board

● Analog Input Terminal Arrangement

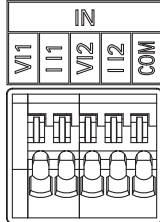

V1	Voltage Input 1
I1	Current Input 1
V2	Voltage Input 2
I2	Current Input 2
COM	Input Common

Note When using current inputs, voltage input terminals must be short-circuited with current input terminals.

● Main Specifications

Item	Specifications	
	Voltage Input	Current Input
Input signal range	0 V to 10 V	0 mA to 20 mA
Max. rated input	0 V to 15 V	0 mA to 30 mA
External input impedance	200 k Ω min.	Approx. 250 Ω
Resolution	1/4000 (full scale)	1/2000 (full scale)
Overall accuracy	25°C: $\pm 0.5\%$ (full scale) 0 to 55°C: $\pm 1.0\%$ (full scale)	25°C: $\pm 0.6\%$ (full scale) 0 to 55°C: $\pm 1.2\%$ (full scale)
A/D conversion data	0000 to 0FA0 hex	0000 to 07D0 hex
Averaging function	Not supported	
Conversion time	Inner sample time 2ms/point Refresh time refers to 18-9 Analog Option Board Refresh Time in the CP1E CPU Unit Software User's Manual (Cat. No. W480)	
Isolation method	None	
Current consumption	5 VDC: 20 mA max.	

Analog Output Option Board

● Analog Output Terminal Arrangement

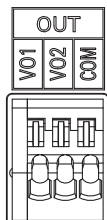

VO1	Voltage Output 1
VO2	Voltage Output 2
COM	Output Common

● Main Specifications

Item	Specifications	
	Voltage Output	Current Output
Output signal range	0 V to 10 V	---
External output allowable load resistance	2 k Ω min.	---
External output impedance	0.5 Ω max.	---
Resolution	1/4,000 (full scale)	---
Overall accuracy	25°C: $\pm 0.5\%$ 0 to 55°C: $\pm 1.0\%$	---
D/A conversion data	0000 to 0FA0 hex	---
Conversion time	Inner conversion time 2ms/point Refresh time refers to 18-9 Analog Option Board Refresh Time in the CP1E CPU Unit Software User's Manual (Cat. No. W480)	
Isolation method	None	
Current consumption	5 VDC: 60 mA max.	

Analog I/O Option Board

● Analog I/O Terminal Arrangement

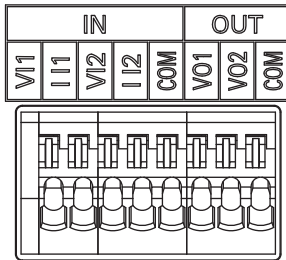

VI1	Voltage Input 1
II1	Current Input 1
VI2	Voltage Input 2
II2	Current Input 2
COM	Analog I/O Common
VO1	Voltage Output 1
VO2	Voltage Output 2
COM	Analog I/O Common

Note When using current inputs, voltage input terminals must be short-circuited with current input terminals.

● Main Specifications

Item		Specifications	
		Voltage I/O	Current I/O
Analog Input Section	Input signal range	0 V to 10 V	0 mA to 20 mA
	Max. rated input	0 V to 15 V	0 mA to 30 mA
	External input impedance	200 k Ω min.	Approx. 250 Ω
	Resolution	1/4,000 (full scale)	1/2,000 (full scale)
	Overall accuracy	25°C: $\pm 0.5\%$ (full scale) 0 to 55°C: $\pm 1.0\%$ (full scale)	25°C: $\pm 0.6\%$ (full scale) 0 to 55°C: $\pm 1.2\%$ (full scale)
	A/D conversion data	0000 to 0FA0 hex	0000 to 07D0 hex
	Averaging function	Not supported	
Analog Output Section	Output signal range	0 V to 10 V	---
	External output allowable load resistance	2 k Ω min.	---
	External output impedance	0.5 Ω max.	---
	Resolution	1/4,000 (full scale)	---
	Overall accuracy	25°C: $\pm 0.5\%$ 0 to 55°C: $\pm 1.0\%$	---
	D/A conversion data	0000 to 0FA0 hex	---
Conversion time	Inner conversion time 6ms (4CH total) Refresh time refers to 18-9 Analog Option Board Refresh Time in the CP1E CPU Unit Software User's Manual (Cat. No. W480)		
Isolation method	None		
Current consumption	5 VDC: 80 mA max.		

3-2 Expansion I/O Units

This section describes the names of the Expansion I/O Unit parts and provides the input specifications and terminal arrangement. Refer to *A-1 Dimensions* for the dimensions, *A-2 Wiring Diagrams* for the wiring diagrams.

3-2-1 Expansion Input Unit

Part Names and Functions

8-point Input Units (CP1W-8ED)

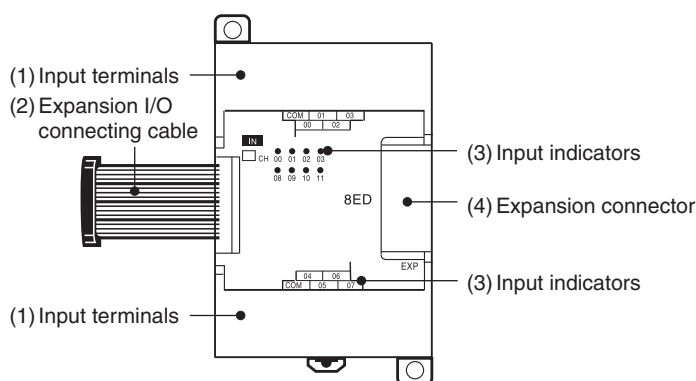

Number	Name	Function
(1)	Input terminals	Used to connect input devices.
(2)	Expansion I/O connecting cable	This is a connection cable to connect the adjacent CPU Unit, Expansion I/O Unit, or Expansion Unit. For extended connections or vertical arrangements, use the CP1W-CN811 I/O Connecting Cable (length: 800 mm).
(3)	Input indicators	Input status is displayed. An indicator will be ON when the input is ON.
(4)	Expansion connector	CP-series Expansion I/O Units or Expansion Units can be connected. Refer to <i>5-2-4 Connecting Expansion I/O Units and Expansion Units</i> .

Terminal Arrangements

The first word of input words allocated to the Expansion Input Unit is indicated by CIO m.

● Input Terminal Arrangement

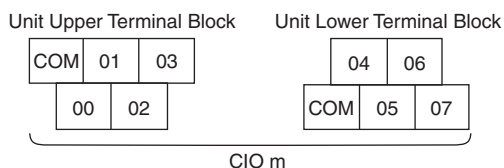

Note COM terminals are connected inside.

3-2-2 Expansion Output Units

Part Names and Functions

**8-point Output Units
CP1W-8ER/8ET/8ET1**

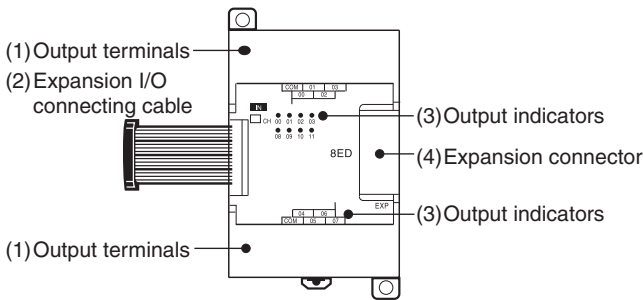

**16-point Output Units
CP1W-16ER/ET/ET1**

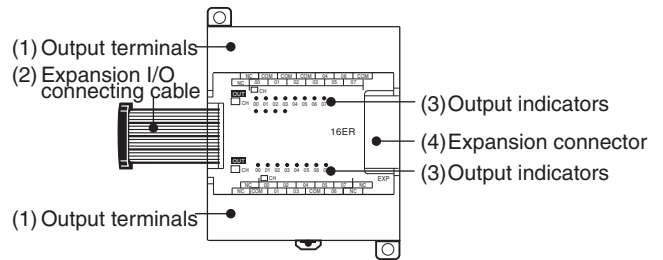

**32-point Output Units
CP1W-32ER/ET/ET1**

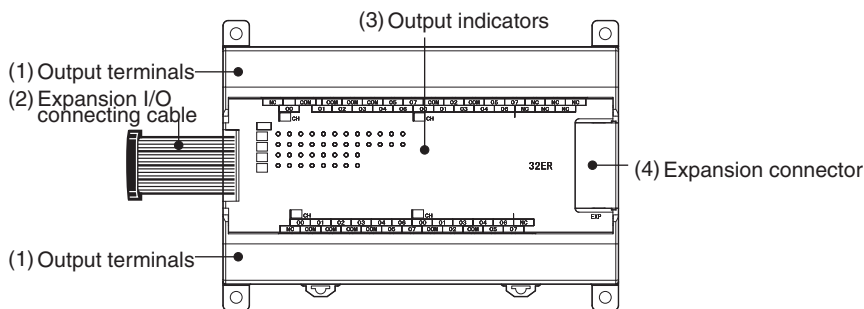

Number	Name	Function
(1)	Output terminals	Used to connect output devices.
(2)	Expansion I/O connecting cable	This is a connection cable to connect the adjacent CPU Unit, Expansion I/O Unit, or Expansion Unit. For extended connections or vertical arrangements, use the CP1W-CN811 I/O Connecting Cable (length: 800 mm).
(3)	Output indicators	Output status is displayed. An indicator will be ON when output is ON.
(4)	Expansion connector	CP-series Expansion I/O Units or Expansion Units can be connected. Refer to 5-2-4 Connecting Expansion I/O Units and Expansion Units.

Terminal Arrangements

The first word of output words allocated to the Expansion Output Unit is indicated by CIO n.

● 8-point Output Units (CP1W-8E□)

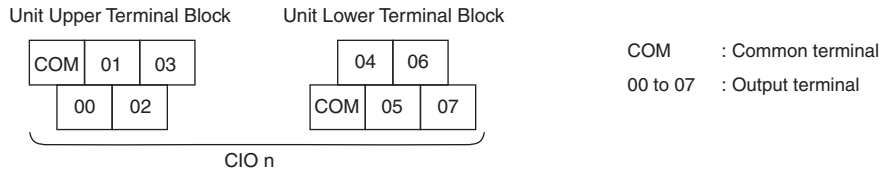

● 16-point Output Units (CP1W-16E□)

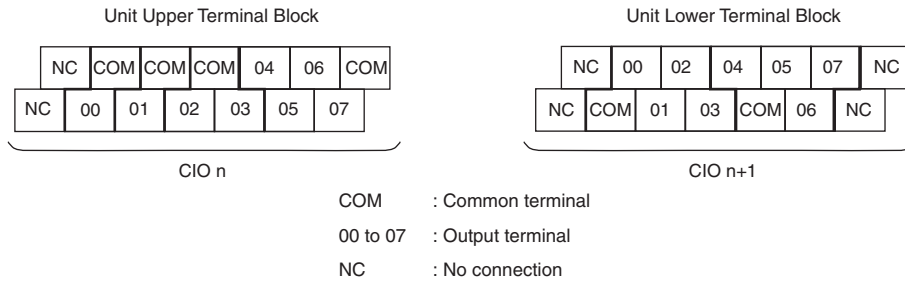

● Units with 32 Output Points (CP1W-32E□)

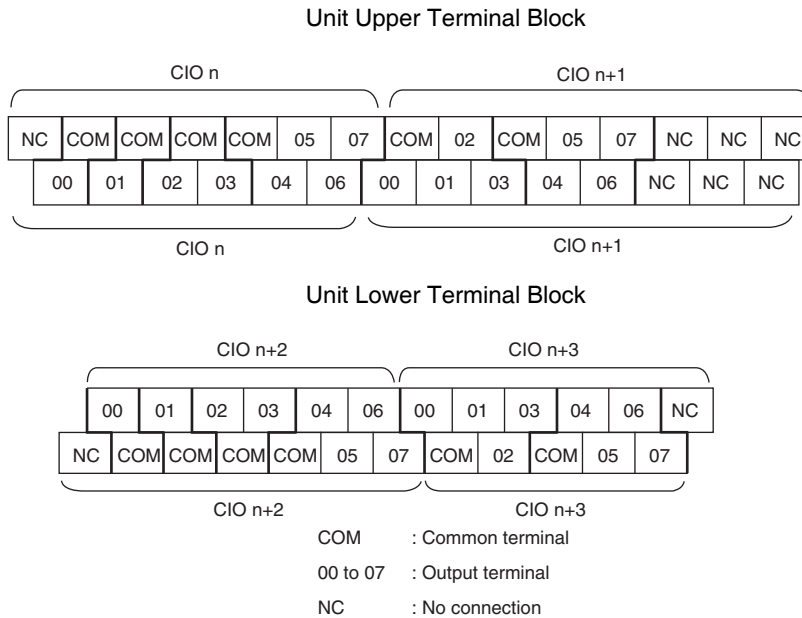

3-2-3 Expansion I/O Units

Part Names and Functions

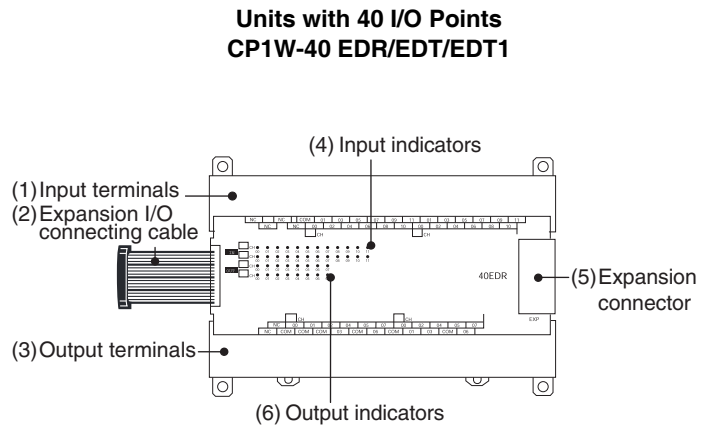
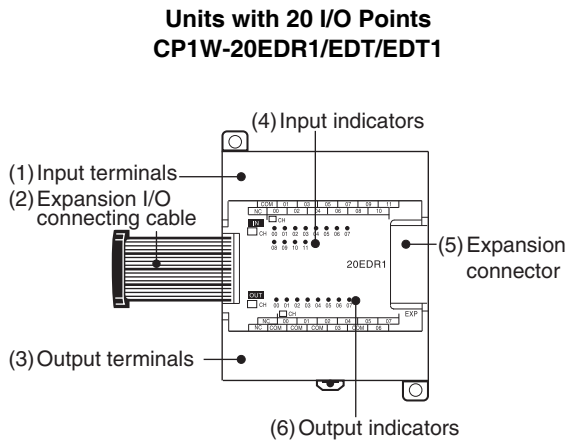

Number	Name	Function
(1)	Input terminals	Used to connect input devices.
(2)	Expansion I/O connecting cable	This is a connection cable to connect the adjacent CPU Unit, Expansion I/O Unit, or Expansion Unit. For extended connections or vertical arrangements, use the CP1W-CN811 I/O Connecting Cable (length: 800 mm).
(3)	Output terminals	Used to connect output devices.
(4)	Input indicators	Input status is displayed. An indicator will be ON when the input is ON.
(5)	Expansion connector	CP-series Expansion I/O Units or Expansion Units can be connected. Refer to 5-2-4 <i>Connecting Expansion I/O Units and Expansion Units</i> .
(6)	Output indicators	Output status is displayed. An indicator will be ON when the output is ON.

Terminal Arrangements

The first word of input words allocated to the Expansion I/O Unit is indicated by CIO m and the first word of the output words by CIO n.

● 20-point I/O Units (CP1W-20ED□)

- Input (Unit Upper Terminal Block)

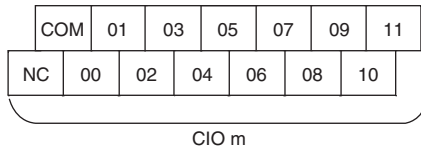

COM : Common terminal
 00 to 11 : Input terminal
 NC : No connection

- Output (Unit Lower Terminal Block)

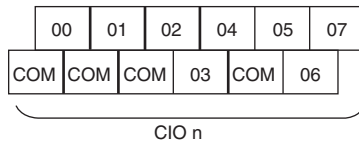

COM : Common terminal
 00 to 07 : Output terminal

● 40-point I/O Units (CP1W-40ED□)

- Input (Unit Upper Terminal Block)

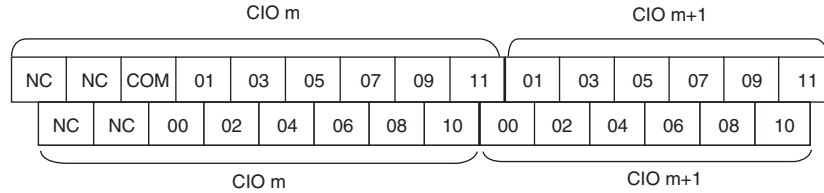

COM : Common terminal
 00 to 11 : Input terminal
 NC : No connection

- Output (Unit Lower Terminal Block)

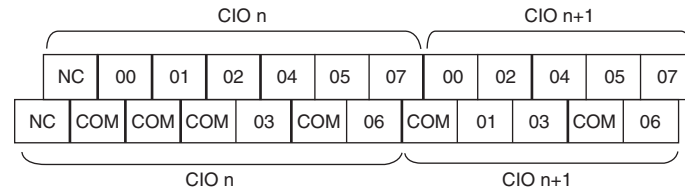

COM : Common terminal
 00 to 07 : Output terminal
 NC : No connection

3-2-4 I/O Specifications

This section describes the I/O specifications common to all Expansion I/O Units.

I/O Specifications

● Input Specifications (CP1W-8ED/20EDR1/20EDT/20EDT1/40EDR/40EDT/40EDT1)

Item	Specification
Input voltage	24 VDC, +10%, -15%
Input impedance	4.7 k Ω
Input current	5 mA typical
ON voltage	14.4 VDC min.
OFF voltage	5.0 VDC max.
ON response time	1 ms max.*
OFF response time	1 ms max.*
Circuit configuration	

* The response time is the delay caused by hardware. The delay set in the PLC Setup (0 to 32 ms, default: 8 ms) must be added to this value. For the CP1W-40EDR/EDT/EDT1, a fixed value of 16 ms must be added.



Precautions for Safe Use

Do not apply voltage in excess of the rated voltage to the input terminal.

● **Output Specifications for Relay Outputs (CP1W-8ER/16ER/20EDR1/32ER/40EDR)**

Item			Specification
Maximum switching capacity			2 A 250 VAC ($\cos\phi = 1$), 2 A 24 VDC (4 A/common)
Minimum switching capacity			10 mA 5 VDC
Service life of relay	Electrical	Resistive load	150,000 operations (24 VDC)
		Inductive load	100,000 operations (240 VAC, $\cos\phi = 0.4$)
	Mechanical		20,000,000 operations
ON response time			15 ms max.
OFF response time			15 ms max.
Circuit configuration			

● **Estimating the Service Life of Relays**

The service life of output contacts is as shown in the following diagram.

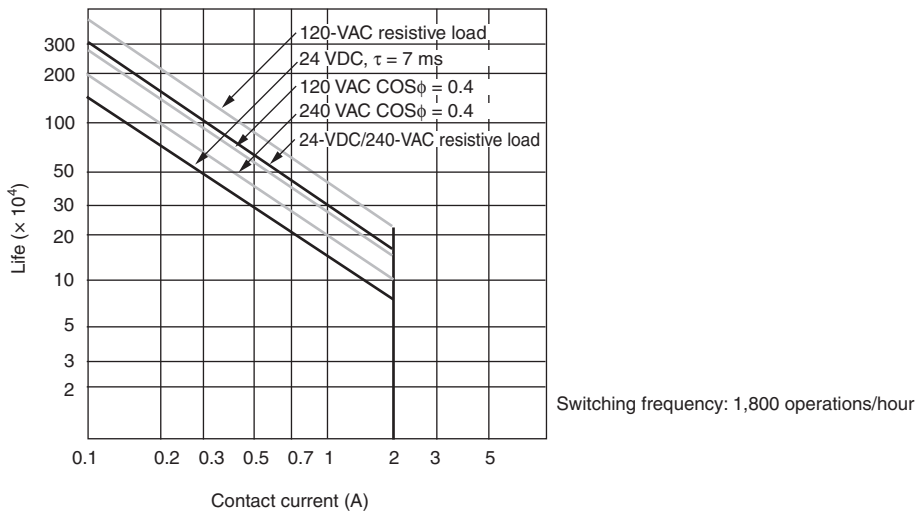

● **Restrictions of CP1W-16ER/32ER**

Limit the output load current to satisfy the following derating curve.

CP1W-16ER/32ER

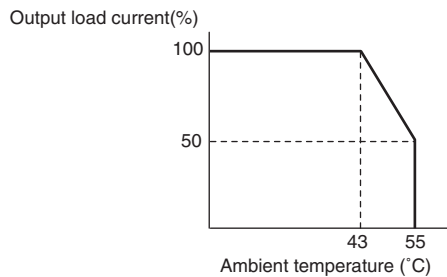

- CP1W-32ER's maximum number of simultaneously ON output points is 24 (75%).

Relation between Number of ON Outputs and Ambient Temperature (CP1W-32ER)

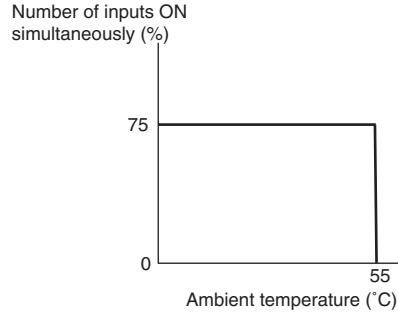

According to the ambient temperature, there are restrictions on power supply voltage and output load current for the CPU Units connected with the Expansion I/O Units (CP1W-8ER/16ER/20EDR1/32ER/40EDR). Use the PLC in the range of the power supply voltage and output load current as show below.

- The ambient temperature is restricted for the CPU Units (CP1E-N/NA□□□□D□-□). Derating curve of the output load current for Expansion I/O Units (CP1W-8ER/16ER/20EDR1/32ER/40EDR).

<p>Connected to CP1E-N30DR-D</p>	<p>Connected to CP1E-N40DR-D</p>	<p>Connected to CP1E-N30□DT□-D</p>	<p>Connected to CP1E-N40□DT□-D</p>
<p>Connected to CP1E-N60DR-D CP1E-N60□DT□-D</p>	<p>Connected to CP1E-NA20DT□-D</p>	<p>Connected to CP1E-NA20DR-A</p>	

● Output Specifications for Transistor Outputs (Sinking or Sourcing)

Item	Specification				
	CP1W-40EDT	CP1W-32ET CP1W-32ET1	CP1W-20EDT CP1W-20EDT1	CP1W-16ET CP1W-16ET1	CP1W-8ET CP1W-8ET1
Maximum switching capacity*1	4.5 to 30 VDC 0.3 A/output 0.9 A/common 3.6 A/Unit	4.5 to 30 VDC 0.3 A/output 0.9 A/common 7.2 A/Unit	24 VDC +10%/-5% 0.3 A/output 0.9 A/common 1.8 A/Unit	4.5 to 30 VDC 0.3 A/output 0.9 A/common 3.6 A/Unit	4.5 to 30 VDC 0.3 A/output 0.9 A/common 1.8 A/Unit
Leakage current	0.1 mA max.	0.1 mA max.	0.1 mA max.	0.1 mA max.	0.1 mA max.
Residual voltage	1.5 V max.	1.5 V max.	1.5 V max.	1.5 V max.	1.5 V max.
ON response time	0.1 ms max.	0.1 ms max.	0.1 ms	0.1 ms max.	0.1 ms max.
OFF response time	1 ms max. At 24 VDC +10%/-5%, 5 to 300 mA	1 ms max. At 24 VDC +10%/-5%, 5 to 300 mA	1 ms max. At 24 VDC +10%/-5%, 5 to 300 mA	1 ms max. At 24 VDC +10%/-5%, 5 to 300 mA	1 ms max. At 24 VDC +10%/-5%, 5 to 300 mA
Maximum number of simultaneously ON outputs	16 points (100% load)	24 points (100% load)	8 points (100% load)	16 points (100% load)	8 points (100% load)
Fuse*2	1 fuse/common				
Circuit configuration					

*1 If the ambient temperature is maintained below 50°C, up to 0.9 A/common can be used.

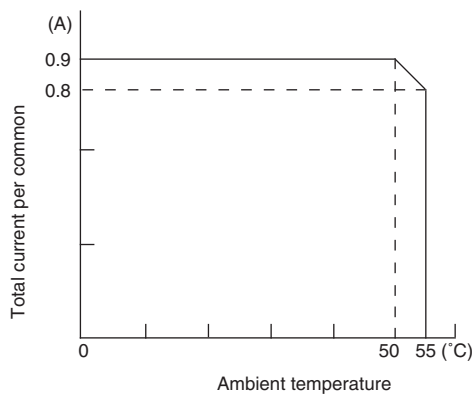

*2 The fuse cannot be replaced by the user. Replace the Unit if the fuse breaks due to an short-circuit or overcurrent.



Precautions for Safe Use

Do not connect a load to an output terminal or apply a voltage in excess of the maximum switching capacity.

4

Programming Device

This section describes the features of the CX-Programmer used for programming and debugging PLCs, as well as how to connect the PLC with the Programming Device.

4

4-1	Applicable Programming Devices for CP1E	4-2
4-1-1	Applicable Programming Devices	4-2
4-1-2	CX-Programmer	4-3
4-1-3	Operating Environment and System Configuration	4-4
4-1-4	Features of the CX-Programmer	4-4
4-1-5	Installing the Software	4-7
4-2	Connecting by USB	4-8
4-2-1	Connecting by USB	4-8
4-2-2	Installing the USB Driver	4-9
4-3	Connection Method with a Serial Port	4-16

4-1 Applicable Programming Devices for CP1E

A programming device is a software application for initializing, programming, monitoring, and debugging PLCs. This section describes the programming device used by CP1E.

4-1-1 Applicable Programming Devices

The programming devices in the following table are used to program and monitor the CP1E Unit.

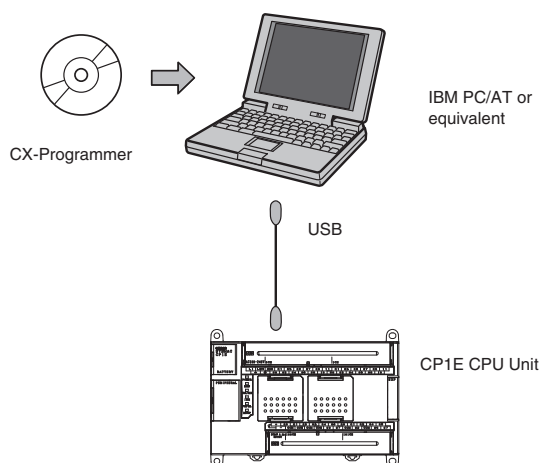

Product	Model	Compatible CX-Programmer versions	Unit version of CP1E CPU Unit	Support for Smart Input	Saved program file extension	Reference	Applicable CPU Unit
CX-Programmer (CX-One)	WS02-CXPC1-V8 CXONE-AL01C-V3	Version 8.2 or higher (See note.)	Version 1.□	Not supported	.CXP	Refer to the <i>CX-Programmer Operation Manual</i> (Cat. No. W446).	CP1E-□20□D□-□ CP1E-□30□D□-□ CP1E-□40□D□-□
	WS02-CXPC1-V9 CXONE-AL01C-V4	Version 9.03 or higher	Version 1.□	Supported			CP1E-E10□D□-□ CP1E-□20□D□-□ CP1E-□30□D□-□ CP1E-□40□D□-□ CP1E-N60□D□-□ CP1E-NA20□D□-□
	CXONE-AL01C-V4	Version 9.42 or higher	Version 1.□	Supported			All units are supported
Micro PLC Edition CX-Programmer (CX-One Lite)	WS02-CXPC2-V8 CXONE-LT01C-V3	Version 8.2 or higher	Version 1.□	Not supported	.CXP	Described in this section.	CP1E-□20□D□-□ CP1E-□30□D□-□ CP1E-□40□D□-□
	WS02-CXPC2-V9 CXONE-LT01C-V4	Version 9.03 or higher	Version 1.□	Supported			CP1E-E10□D□-□ CP1E-□20□D□-□ CP1E-□30□D□-□ CP1E-□40□D□-□ CP1E-N60□D□-□ CP1E-NA20□D□-□
	WS02-CXPC2-V9 CXONE-LT01C-V4	Version 9.42 or higher	Version 1.□	Supported			All units are supported
CX-Programmer for CP1E	WS02-CXPC3	Version 1.0	Version 1.□	Supported	.CXE		CP1E-□20□D□-□ CP1E-□30□D□-□ CP1E-□40□D□-□

Note 1 To use CX-Programmer version 8.2 with a CP1E CPU Unit, the CX-One version 3 auto-update must be installed.

2 Use the CX-Programmer version 9.12 or higher, when CP1W-CIF41 is applied.

- The CX-Programmer for CP1E and CX-Programmer (CX-One/CX-One Lite) can be used at the same time.
- The CX-Programmer (CX-One/CX-One Lite) and the CX-Programmer for CP1E can be installed on the same computer and both applications can be run at the same time.



Precautions for Correct Use

- This section describes the unique applications and functions of the Micro PLC Edition CX-Programmer version 9.03 or higher/CX-Programmer for CP1E. In the remainder of this section, “CX-Programmer” refers to the Micro PLC Edition CX-Programmer version 9.03 or higher/CX-Programmer for CP1E.
When using the full version of CX-Programmer provided in CX-One, refer to the *CX-Programmer Operation Manual* (Cat. No. W446).
- A Programming Console cannot be used for the CP1E. Use the CX-Programmer.
- The windows described in this section are the windows using the CX-Programmer for CP1E. When using the CX-Programmer or the Micro PLC Edition CX-Programmer, the specification may be different. Check the window specifications sufficiently.
Refer to the *CX-Programmer Operation Manual* (Cat. No. W446) for details.

● Using Project Files Saved with the CX-Programmer (.CXP) on the CX-Programmer for CP1E

The CX-Programmer for CP1E cannot open a .CXP project created on the CX-Programmer (CX-One/CX-One Lite). Use programming from a project saved in a .CXP file on the CX-Programmer for CP1E according to the following procedure.

- 1** Start the CX-Programmer (CX-One/CX-One Lite) and CX-Programmer for CP1E together.
- 2** Copy the rungs of the program to be used from the Ladder Programming Window of the CX-Programmer (CX-One/CX-One Lite), and paste them into the CX-Programmer for CP1E.



Additional Information

Files created with the CX-Programmer for CP1E (.CXE) can be opened with CX-Programmer version 8.2 and higher.

4-1-2 CX-Programmer

CX-Programmer

The CX-Programmer is a basic software application for creating and debugging PLC programs.

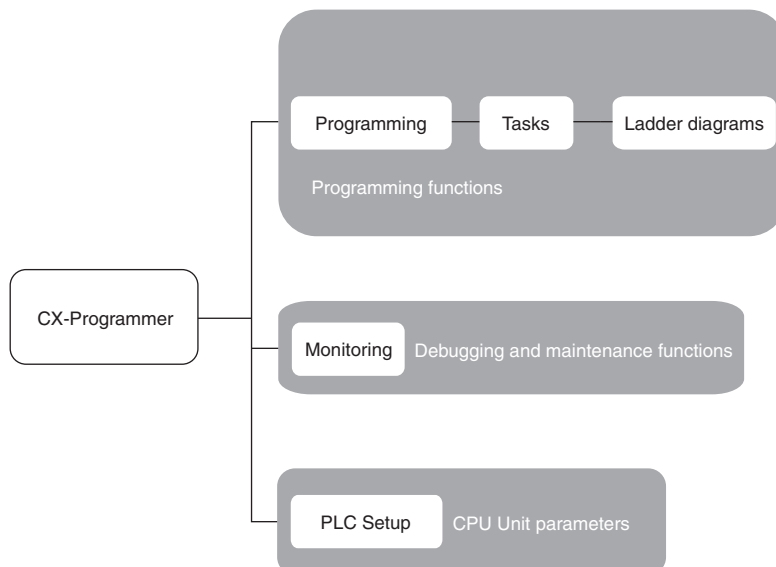

4-1-3 Operating Environment and System Configuration

The following system is required to operate the CX-Programmer. Make sure your system provides the following conditions and has the necessary components.

Item	Description
Supported computer	IBM PC/AT or equivalent
CD-ROM or DVD-ROM drive	One or more
Supported operating systems	Windows XP (Service Pack 3 or higher), Vista, 7 or 8 Note Except for Windows XP 64-bit version.
CPU	Pentium II 333 MHz or faster
RAM	256 MB min., 512 MB or more recommended
Required hard disk space	600 MB min.
Display	800 x 600 SVGA min.
PLC and connection port	USB port

4-1-4 Features of the CX-Programmer

Simple Menu Configuration

- With two menu levels, menu commands can be easily found.
- Options have been simplified.

Smart Input Mode That Automatically Displays Candidates

● Automatic Instruction Candidate Function

When the first letter of the instruction mnemonic is input, possible instructions are automatically displayed.

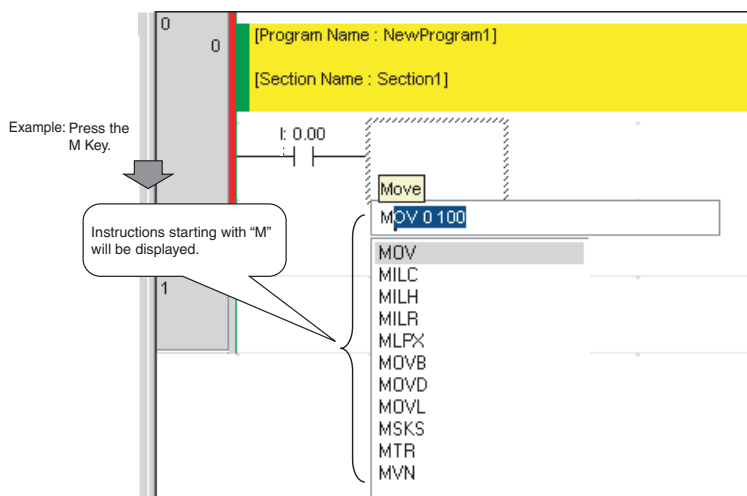

● Automatic Address Increment Function

The addresses are automatically incremented to the addresses input last time by 1.

The addresses of inputs and outputs are incremented by 1 respectively.

- +1 bit for a bit address
- +1 word for a word address

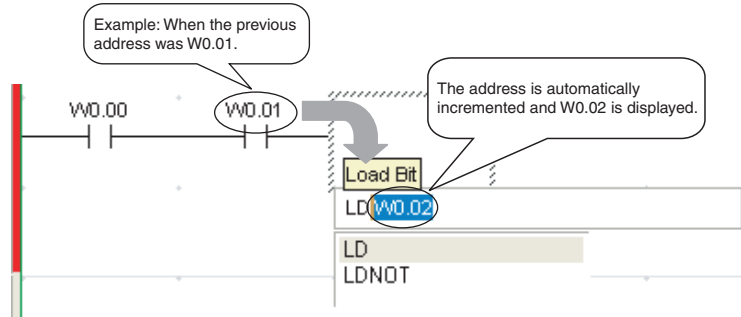

● System-defined Symbol List

Condition Flags are also displayed in a list as candidates.

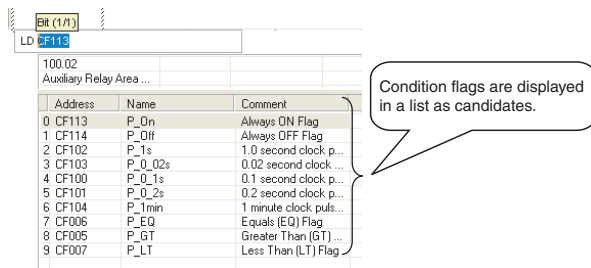

● Automatic Symbol Candidate Function

When inputting symbol names, symbol candidates are automatically displayed based on the first letter.

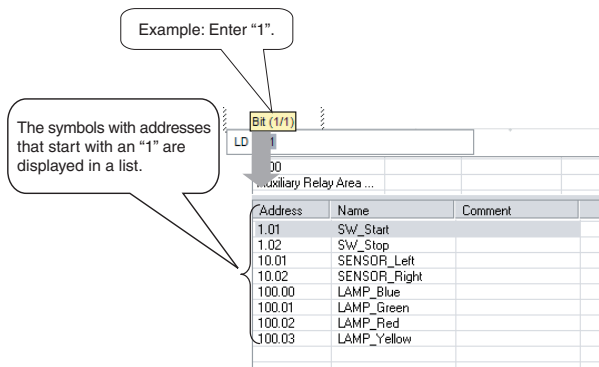

Instructions Can Be Copied with Automatic Address Incrementing

● Automatic Address Incrementing

A copied group of ladder instructions can be pasted with a specified address offset (e.g., 16 bits).

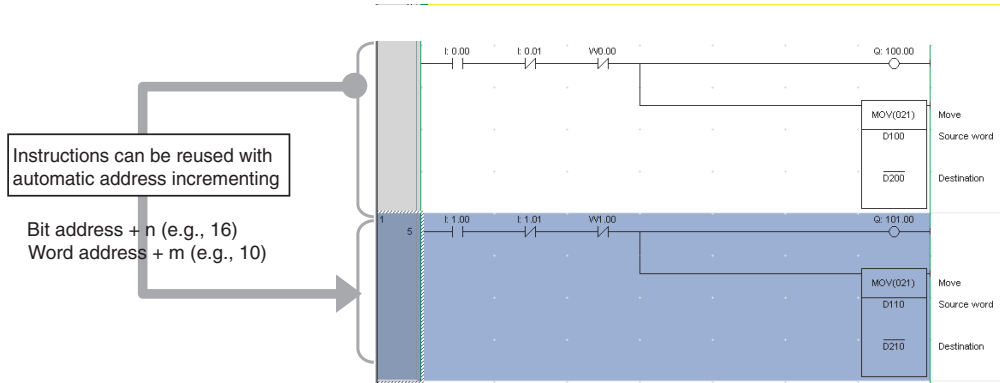

● Automatic Generation of Symbol Names and I/O Comments

If there is a symbol name or I/O comment when instructions are copied, new symbols and I/O comments will also be automatically generated.

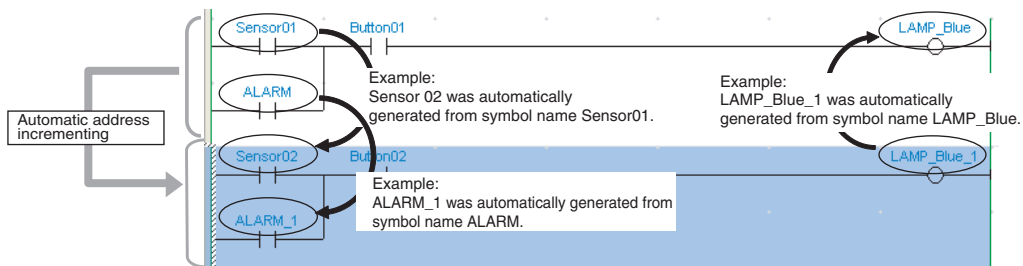

4-1-5 Installing the Software

This section provides a simple description of how to install the CX-Programmer on the hard disk of a computer.

Preparing for Installation

Check the following items before beginning with the installation.

- **Available Hard Disk Space**

The CX-Programmer can be installed on the hard disk only. At least 600 MB of hard disk space is required. Make sure that there is enough space available.

- **Windows Environment and Installation Destination**

The CX-Programmer is a software application for a Windows operating environment. The software is installed on top of Windows. Make sure that Windows Vista, XP or Windows 2000 is installed and functioning correctly on the computer.

- **USB Port**

To transfer ladder programs from the computer to the CP1E and to use the monitoring functions via the USB port, enable the computer's USB port. Refer to the computer's manual for information on enabling the USB port.

Installation Procedure

This section describes how to install the software on a computer using the following drive configuration as an example.

C drive: Hard disk drive

D drive: CD-ROM drive

- 1** Start Windows and insert the CX-Programmer Master Disk in the CD-ROM drive.
The installation program will be started by the computer's auto-run function. If the installation program does not start, select **Specify File Name and Run** from the Windows Start Menu, enter "d:\setup" and click the **OK** Button.
- 2** Complete the installation process following the instructions provided on-screen.



Precautions for Correct Use

Log on as a user with Administrator privileges when uninstalling.

Uninstalling the CX-Programmer

Uninstall the CX-Programmer when it is no longer required. Uninstall the application using **Add and Remove Applications** in the control panel.



Precautions for Correct Use

Log on as a user with Administrator privileges when uninstalling.

4-2 Connecting by USB

This section describes how to connect a computer running the CX-Programmer and the CP1E CPU Unit.

4-2-1 Connecting by USB

Preparations for Connection

The USB driver must be installed in the computer to connect the PLC to the computer using the USB port. Refer to 4-2-2 *Installing the USB Driver* for the installation of the USB driver.

Connection Methods

Using commercially available USB cable, connect the CX-Programmer to the peripheral USB port on the CPU Unit.

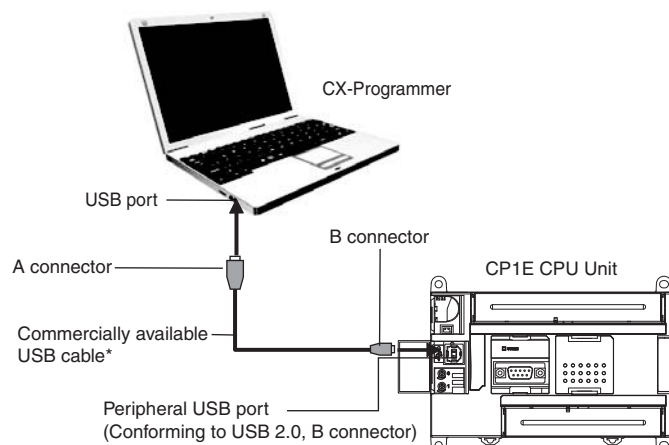

* Commercially available USB cable: 5 m max., for USB 2.0.

Connecting Cable

Use the following cable to connect the CP1E CPU Unit to the CX-Programmer.

Port at Unit	Port at computer	Network type (communications mode)	Model numbers	Length
Peripheral USB port (Conforming to USB 2.0, B connector)	USB port	USB 2.0 (or 1.1)	Commercially available USB cable (A connector - B connector)	5m max.

Restrictions on Connecting by USB

The following restrictions apply to the connection of the CP1E to a computer due to the USB specifications. Keep these restrictions in mind when using the USB port.

- Only one CP1E CPU Unit can be connected by USB to a single personal computer. It is not possible to connect multiple CP1E CPU Units simultaneously.
- Do not remove the USB cable while connected online. The application must be offline before the cable is removed. The CX-Programmer will not go online simply by reinserting the USB cable. Place the CX-Programmer offline before reinserting the USB cable, then place it online again.
- If the cycle time is too long, it may result the communication failure when CX-Programmer tries to work online. In this case, click the **Settings** button on the right side of Network Type in the **Change PLC** dialog box and increase the value in **Response Timeout(s)**.

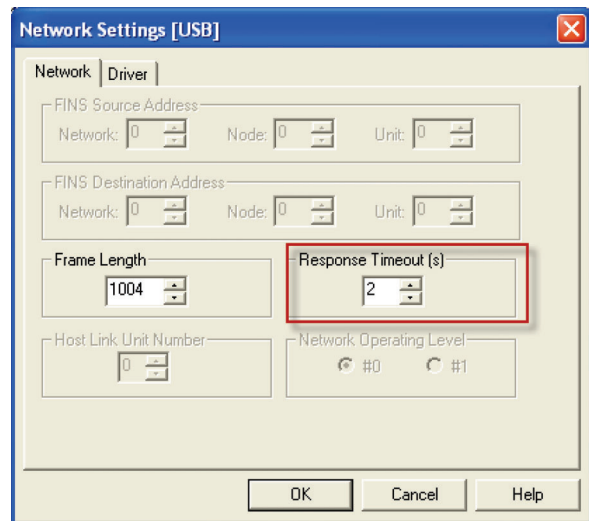
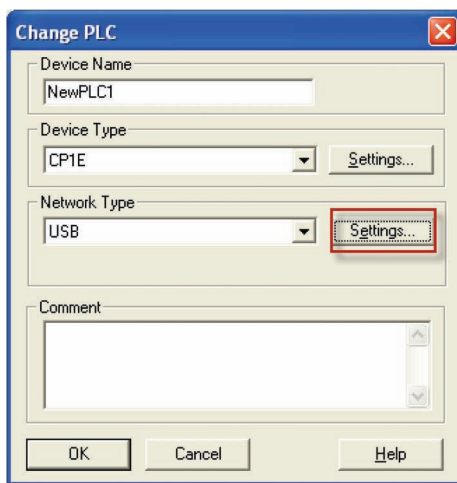

4-2-2 Installing the USB Driver

The USB driver for CP1E must be installed on the computer running the CX-Programmer in order to connect the CP1E to the computer via USB.

When the personal computer is connected to the CP1E by USB cable, the personal computer automatically recognizes the device and the USB driver installation is started.

Windows 2000 or Vista

Connect the computer's USB port (1) and the CP1E CPU Unit's peripheral USB port (3) with a USB cable (2).

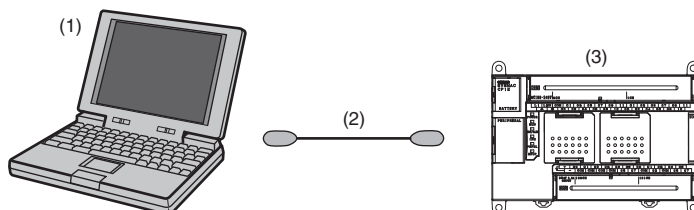

The USB driver will be automatically installed when the cable is connected.



Additional Information

If the software is not automatically installed, refer to *Installing a Specified USB Driver* later in this section.

Windows XP

1 Turn ON the power supply to the PLC and connect the peripheral USB port on the PLC to the personal computer using a USB cable. The computer will automatically detect the device when the cable is connected and display the following message.

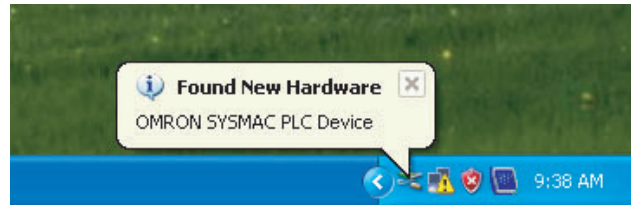

2 The following dialog box will be displayed. Select one of the options and click the **Next** Button.

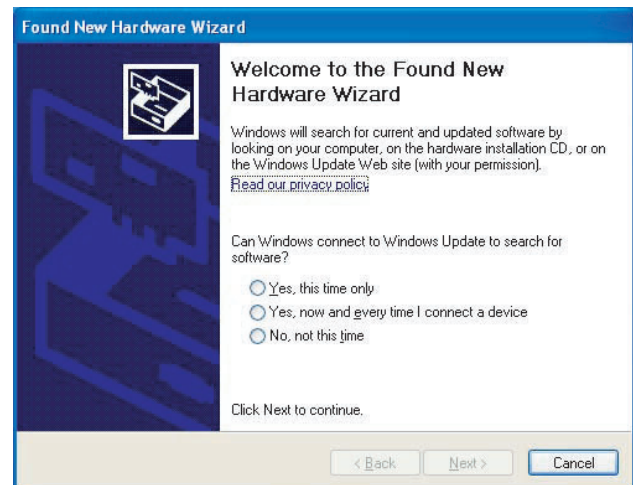

3 The following dialog box will be displayed. Select the *Install the software automatically (Recommended)* Option and click the **Next** Button.

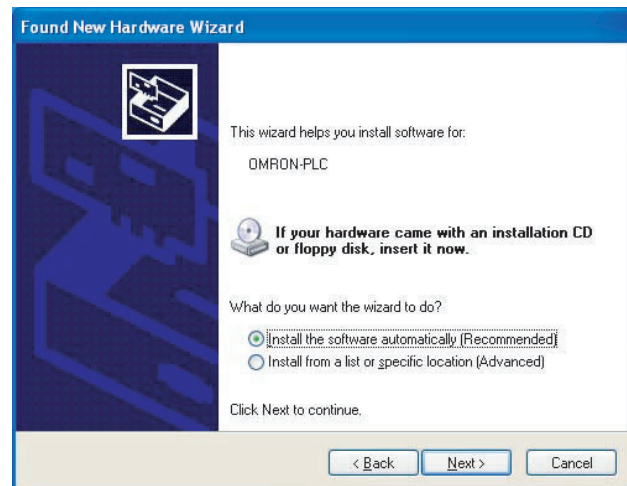



Additional Information

- If the software cannot be installed automatically, refer to *Installing a Specified USB Driver* later in this section.
- If the installation media is not inserted or the USB device driver is installed for another port, a Driver List Dialog Box will be displayed. Make sure that the newest driver is selected and click the **Next** Button.

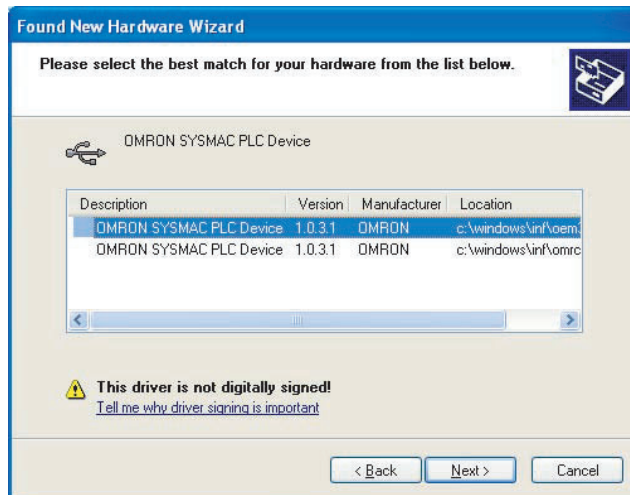

- 4 Ignore the following dialog box if it is displayed and click the **Continue Anyway** Button.



- 5 The following dialog box will be displayed if the installation is completed normally. Click the **Finish** Button.



Installing a Specified USB Driver

If the USB driver cannot be installed automatically, use the following procedure to install it.

● Windows Vista

1 Turn ON the power supply to the PLC and connect the peripheral USB port on the PLC to the personal computer using a USB cable.

2 The following dialog box will be displayed. Select **Locate and install driver software (Recommended)**.

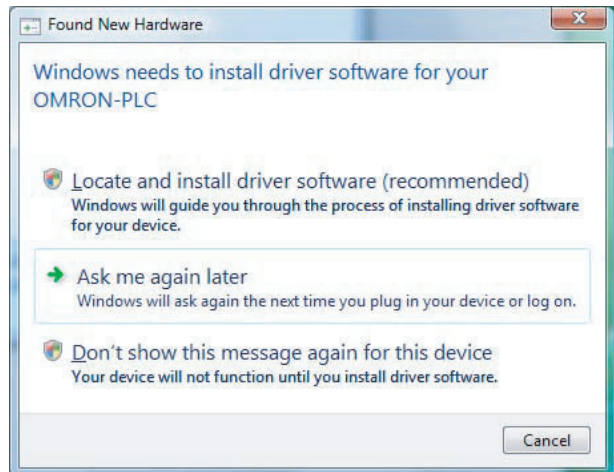

3 The following dialog box will be displayed. Select **I don't have the disc. Show me other options.**

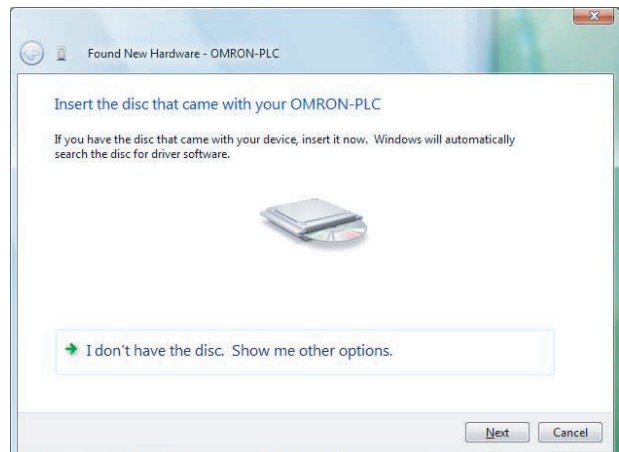

4 The following dialog box will be displayed. Click the **Browse** Button, specify the following location, and then click the **Next** Button.
C:\Program Files\OMRON\CX-Server\USB\wind2000_XP\Inf

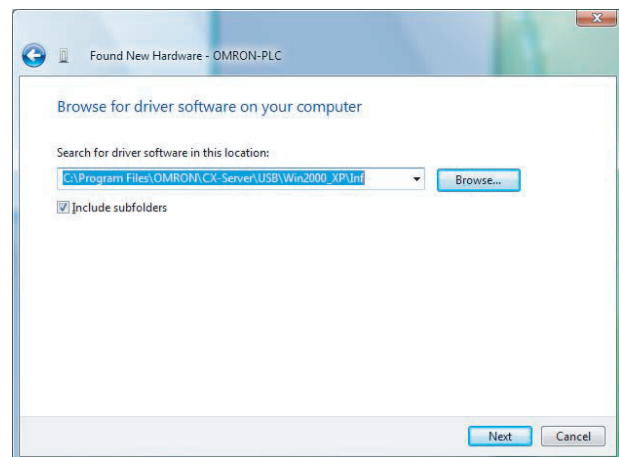

- 5 Ignore the following dialog box if it is displayed and select **Install this driver software anyway**.

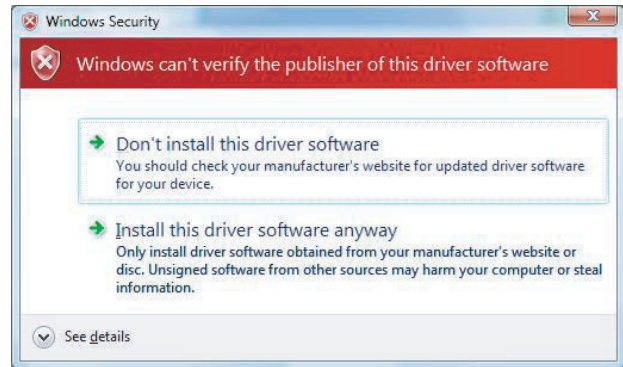

The following dialog box will be displayed when the driver software has been installed successfully.

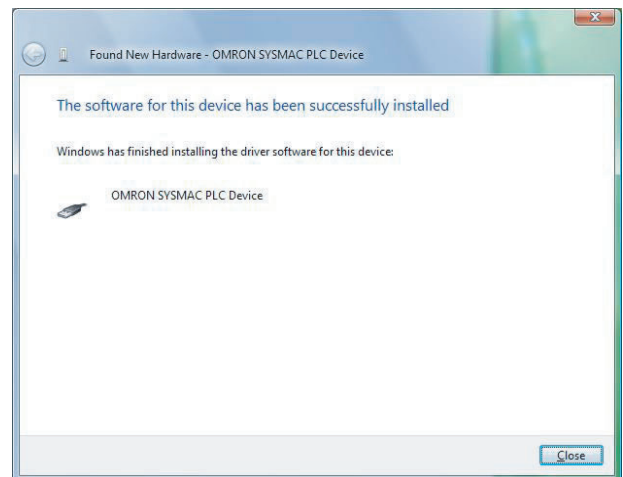

Confirming Installation

Check that the driver has been installed correctly after the installation.

- 1 From the desktop click **Start** and right-click **My Computer**. A pop-up menu will be displayed.
- 2 Select **Properties**.
The **System Properties** Dialog Box will be displayed.
- 3 Click the **Hardware** Tab and click the **Device Manager** Button.
The **Device Manager** Dialog Box will be displayed.
- 4 Double-click the **USB (Universal Serial Bus) Controller** Device.
- 5 Check that **OMRON SYSMAC PLC Device** is displayed. If it appears, then the USB driver has been installed correctly.

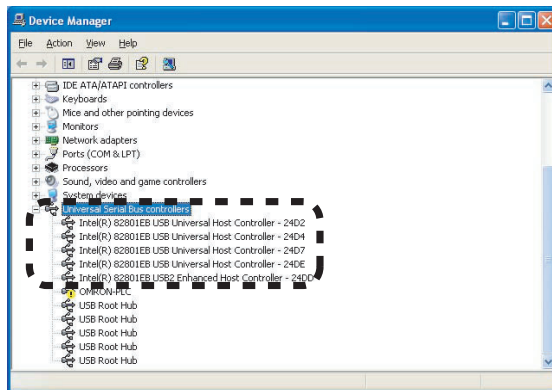

- 6 Close the **Device Manager** Dialog Box and **System Properties** Dialog Box.
If OMRON SYSMAC PLC Device does not appear, reinstall the USB driver.

Uninstalling the USB Driver

If the USB driver installation fails for some reason or is cancelled in progress, the USB driver must be reinstalled.

First, check whether installation failed.

- 1 Display the Device Manager on the computer.
If **USB Device** is displayed for **Other Devices**, it means that the USB driver installation has failed.
- 2 Right-click on **USB Device** and select **Delete** to delete the driver. Reinsert the USB cable to display the USB driver installation dialog box. Install the driver following the instructions again.

Re-installing the USB Driver

- 1 Right-click *OMRON-PLC* under *Universal Serial Bus controllers* and select **Properties**. The properties will be displayed.

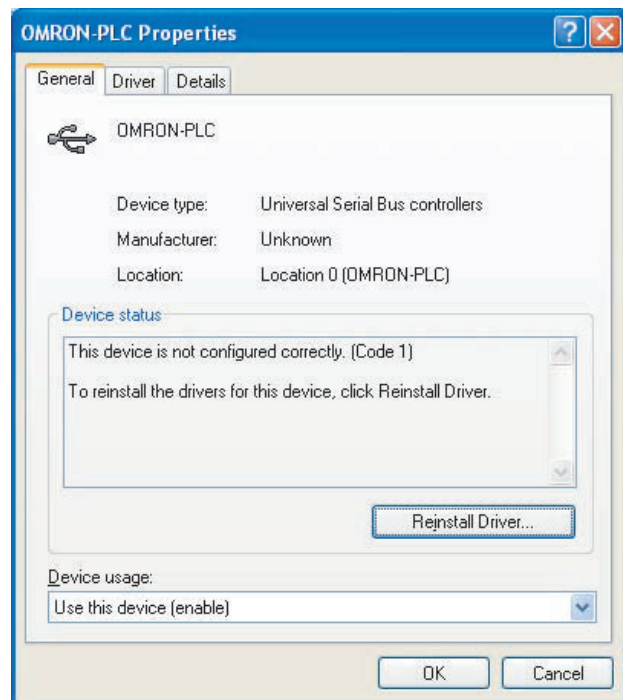

- 2 Click the **Reinstall Driver** Button. The Hardware Update Wizard Dialog Box will be displayed. Install the driver software using the procedure described in *4-2-2 Installing the USB Driver*

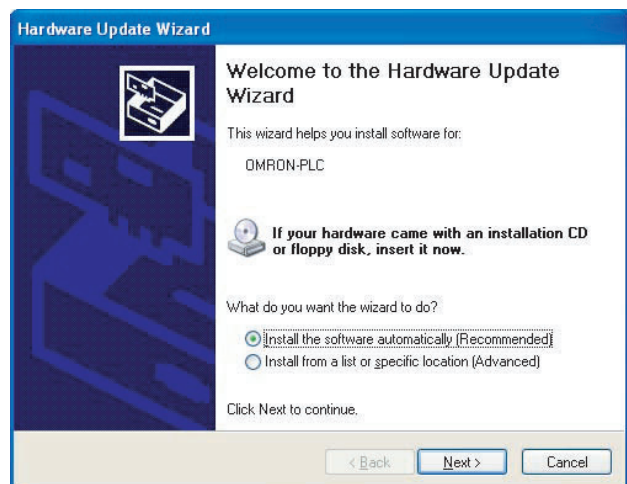

4-3 Connection Method with a Serial Port

Using a built-in RS-232C port makes it possible to connect Support Software with serial communications.

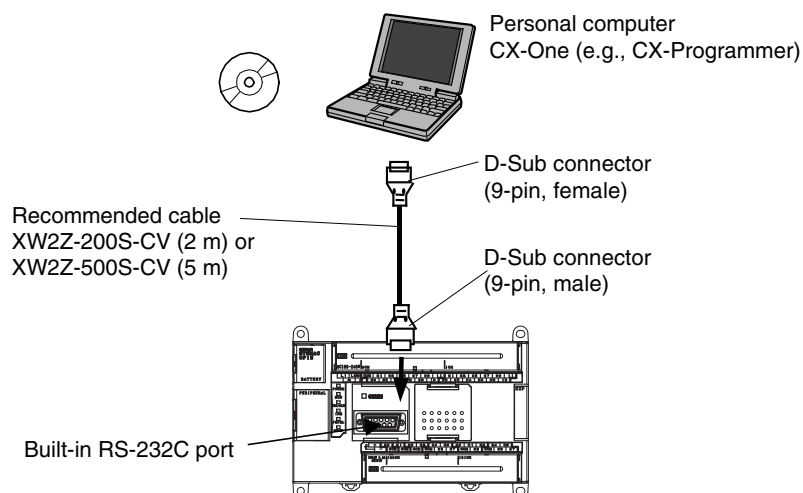

Connect the CX-Programmer to the built-in RS-232C port by XW2Z-200S-CV/500S-CV RS-232C cable.

Connection Method

Connect the Programming Device using the Connecting Cable that is appropriate for the serial communications mode of the computer and CPU Unit.

Computer		Connecting Cable		CP1E CPU Unit	
Connector	Model	Length	Connector	Serial communications mode	
D-Sub 9 pin,male	XW2Z-200S-CV	2m	D-Sub 9 pin, female(With a built-in RS-232C port or a CP1W-CIF01 mounted in option board slot)	Host Link (SYSWAY)	
	XW2Z-500S-CV	5m			

5

Installation and Wiring

This section describes how to install and wire CP1E Units.

5-1	Fail-safe Circuits	5-2
5-2	Installation	5-3
5-2-1	Installation Location	5-3
5-2-2	Unit Arrangement	5-6
5-2-3	Installation	5-7
5-2-4	Connecting Expansion I/O Units and Expansion Units	5-12
5-3	Wiring	5-14
5-3-1	Wiring Procedure	5-14
5-3-2	Wiring Power Supply and Ground Lines	5-14
5-3-3	I/O Wiring	5-17
5-3-4	Wiring Safety and Noise Controls	5-21
5-3-5	Relay Output Noise Reduction Methods	5-22

5-1 Fail-safe Circuits

This section describes the fail-safe circuits that must be set up outside the CP1E.

Always set up safety circuits outside of the PLC to prevent dangerous conditions in the event of errors in the CP1E CPU Unit or external power supply.

In particular, be careful of the following points.

Timing of Supplying Power to the PLC and the Controlled System

If the PLC's power supply is turned ON after the controlled system's power supply, outputs in Units such as DC Output Units may momentarily not function properly.

To prevent any malfunction, add an external circuit that prevents the power supply to the controlled system from going ON before the power supply to the PLC itself.

Safety Circuit for Errors (Outputs Turned OFF)

When any of the following errors occur, PLC operation (program execution) will stop and all outputs from the Units will be turned OFF.

- A CPU error (watchdog timer error) or CPU on standby
- A fatal error (memory error, I/O bus error, too many I/O points error, program error, cycle time exceeded error, or FALS error)

Be sure to add any circuits necessary outside of the PLC to ensure the safety of the system in the event of an error that stops PLC operation.

Safety Circuit after a Malfunction (When an Output Remains ON)

It is possible for an output to remain ON due to a malfunction in the internal circuitry of the Output Unit, such as a relay or transistor malfunction. Always add any circuits necessary outside of the PLC to ensure the safety of the system in the event that an output fails to go OFF.

External Interlock Circuits

When the PLC controls operation such as the clockwise and counterclockwise operation of a motor and if there is any possibility of an accident or mechanical damage due to faulty PLC operation, provide an external interlock such as the one shown below to prevent both the forward and reverse outputs from turning ON at the same time.

Example:

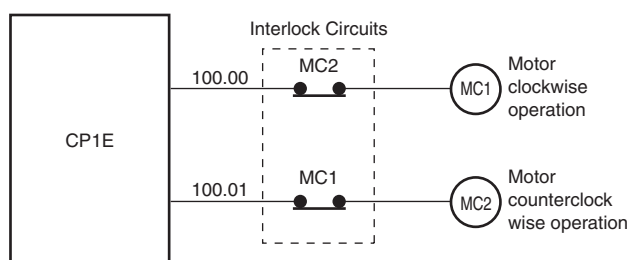

A circuit like the one shown in the diagram on the left is required to prevent outputs MC1 and MC2 from both being ON at the same time even if both PLC outputs CIO 100.00 and CIO 100.01 are both ON.

5-2 Installation

This section describes the environmental factors that must be considered and the installation location of each Unit.

5-2-1 Installation Location

Installation Environment

Do not install the Unit in the following locations.

- Locations subject to ambient temperatures lower than 0°C or higher than 55°C.
- Locations subject to drastic temperature changes or condensation.
- Locations subject to ambient humidity lower than 10% or higher than 90%.
- Locations subject to corrosive or flammable gases.
- Locations subject to excessive dust, salt, or metal filings.
- Locations that would subject the PLC to direct shock or vibration.
- Locations exposed to direct sunlight.
- Locations that would subject the PLC to water, oil, or chemical reagents.

Always enclose or protect the PLC sufficiently in the following locations.

- Locations subject to static electricity or other forms of noise.
- Locations subject to strong electromagnetic fields.
- Locations subject to possible exposure to radioactivity.
- Locations close to power lines.

Installation in Cabinets or Control Panels

When the CP1E is being installed in a cabinet or control panel, be sure to provide proper ambient conditions as well as access for operation and maintenance.

● Installation Orientation

When installing the CP1E in a control panel, it must be installed with the side with indicators and communications ports facing the front to ensure proper heat dissipation.

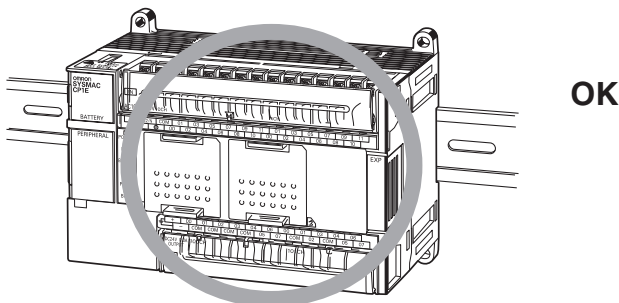

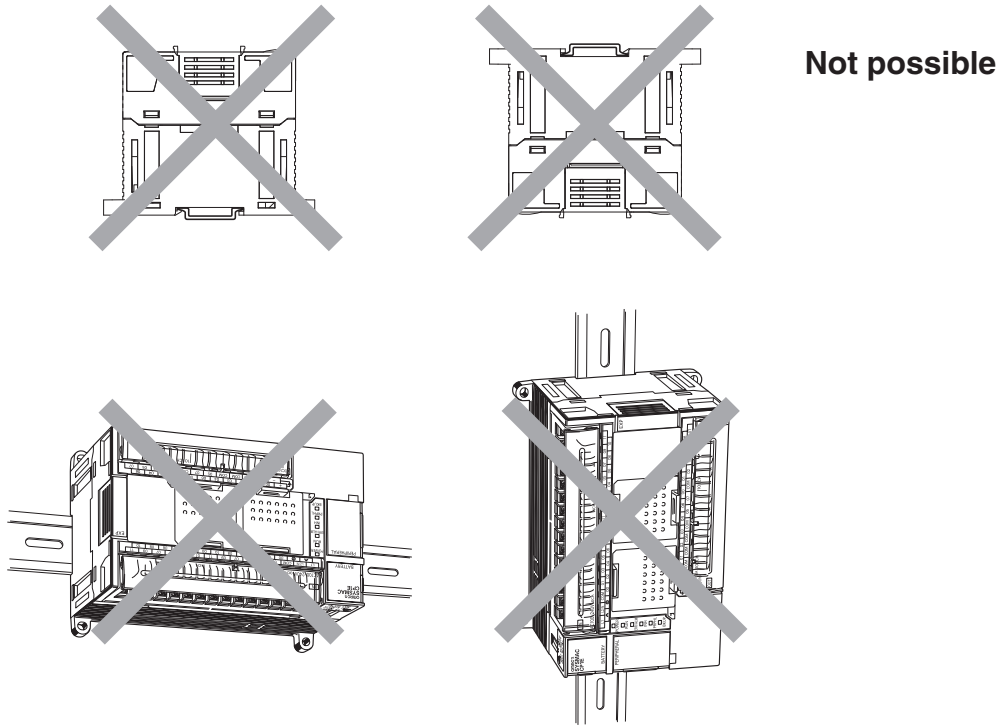

● **Accessibility for Operation and Maintenance**

- To ensure safe access for operation and maintenance, separate the PLC as much as possible from high-voltage equipment and moving machinery.
- The PLC will be easiest to install and operate if it is mounted at a height of 1.0 to 1.6 m above the floor.

WARNING

Do not touch the power supply or the area around the I/O terminals while power is being supplied or immediately after power has been turned OFF.
Doing so may result in burns.





Precautions for Correct Use

After the power supply has been turned OFF, wait until the PLC has sufficiently cooled before touching it.

● Improving Noise Resistance

Leave space between the CP1E and control panel or other devices to allow adequate dissipation of heat generated by the power supply.

- Do not mount the PLC in a control panel containing high-voltage equipment.
- Install the PLC at least 200 mm (6.5 feet) from power lines.

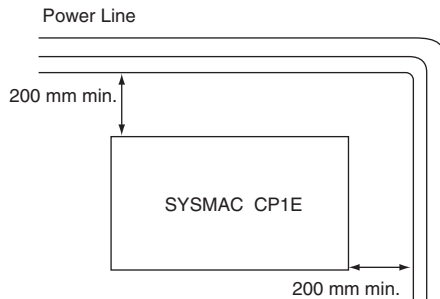

- Ground the mounting plate between the PLC and the mounting surface.

● Temperature Control

The ambient operating temperature around the CP1E must be between 0 and 55°C. Observe the following precautions.

- Provide enough space for good air flow.
- Do not install the PLC above equipment that generates a large amount of heat such as heaters, transformers, or high-capacity resistors.
- If the ambient temperature exceeds 55°C, install a cooling fan or air conditioner.

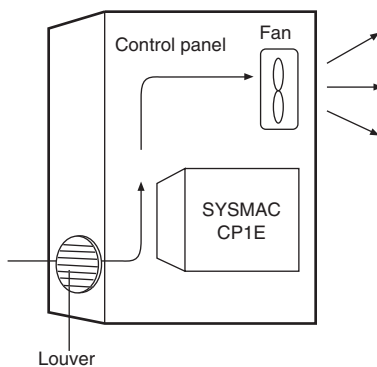

5-2-2 Unit Arrangement

This section describes how to arrange the CP1E Units.

As shown in the following diagrams, Units can be arranged in one or two rows when Expansion I/O Units or Expansion Units are used.

Arrangement in One Row

Expansion I/O Units and Expansion Units can be installed in a side-by-side arrangement.

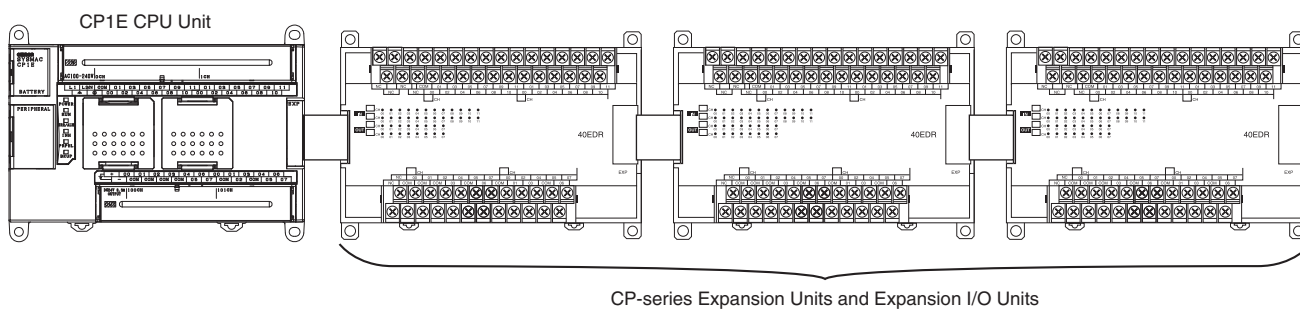

Precautions for Correct Use

When connecting CP-series Expansion Units or Expansion I/O Units to a CPU Unit with AC power, provide a space of approximately 10 mm between the CPU Unit and the first Expansion Unit or Expansion I/O Unit.

If sufficient space cannot be provided between the CPU Unit and the first Expansion Unit or Expansion I/O Unit, use the PLC in an ambient temperature of 0 to 50°C.

Arrangement in Two Rows

The Units can be arranged in two rows using the CP1W-CN811 I/O Connecting Cable (800 mm).

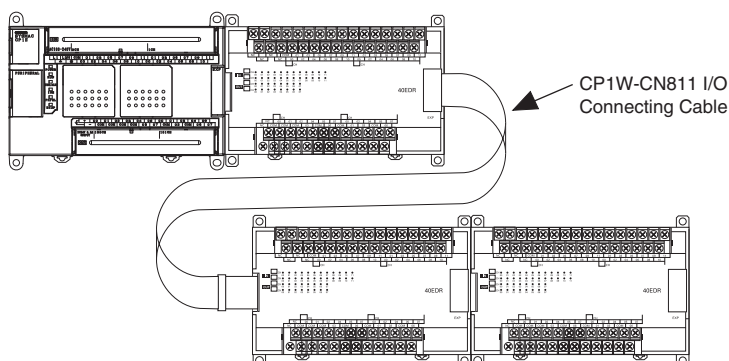

Precautions for Correct Use

I/O Connecting Cable can be used in one place only in each CP1E PLC. It cannot be used in more than one place in the same CP1E PLC.

5-2-3 Installation

This section describes how to install the CP1E.

Dimensions and Installation Height

● Dimensions

- E□□-type and N/NA□□-type CPU Units

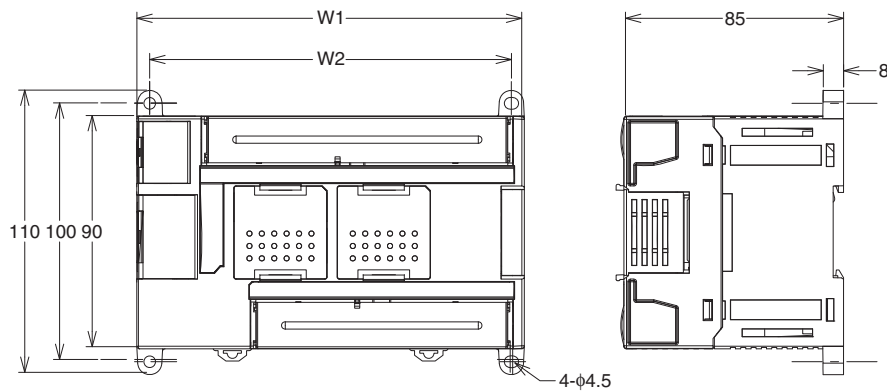

Model number	W1	W2
CP1E-E10D□-□	66	56
CP1E-□14D□-□	86	76
CP1E-□20D□-□	86	76
CP1E-□30D□-□	130	120
CP1E-□40D□-□	150	140
CP1E-N60D□-□	195	185
CP1E-NA20D□-□	130	120

- E□□S-type and N□□S(1)-type CPU Units

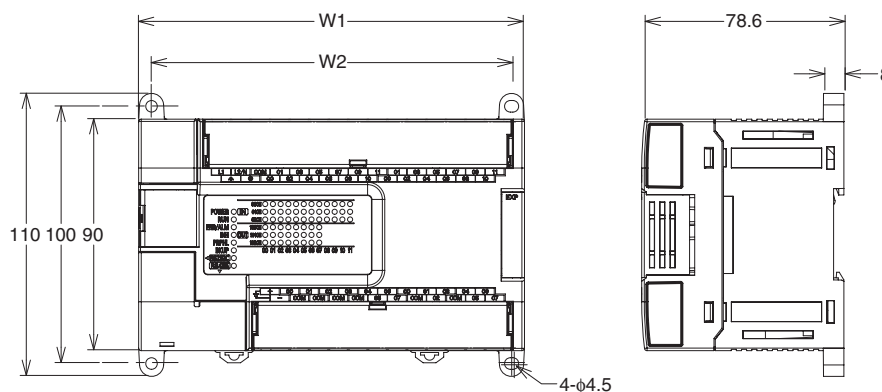

Model number	W1	W2
CP1E-E14SD□-□	86	76
CP1E-E20SD□-□	86	76
CP1E-□30S(1)D□-□	130	120
CP1E-□40S(1)D□-□	150	140
CP1E-□60S(1)D□-□	195	185

● Installation Height

The installation height is approximately 90 mm.

When a cable is connected to an Option Board, however, the additional height must be included. Always allow for the additional height when considering the depth of the control panel in which the PLC is to be mounted.

Installation Methods

There are two installation methods.

● DIN Track Installation

- Units can be mounted to PEP-50N (50 cm) or PEP-100N/100N2 (100 cm) DIN Tracks.
- Units can be moved and removed easily.
- The installation height in the control panel will be increased depending on the type of DIN tracks used.

● Surface Installation

Units can be directly mounted in the control panel using M4 screws.

Installation Example

● DIN Track Installation

Secure the DIN Track with screws in at least three places.

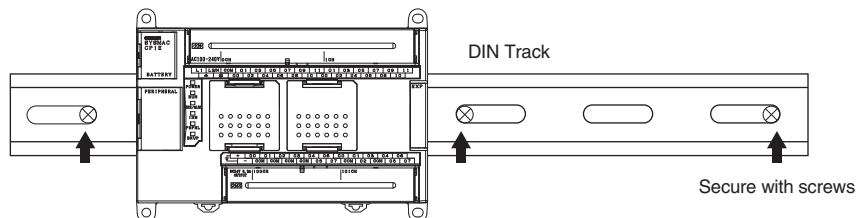

● Surface Installation

A CP1E CPU Unit and CP-series Expansion I/O Units and Expansion Units can be mounted using M4 screws. For restrictions on the number of Expansion I/O Units and Expansion Units that can be connected, refer to *2-3 Expansion I/O Unit or Expansion Unit*.

DIN Track Installation

- 1 Use a screwdriver to pull down the DIN Track mounting pins from the back of the Units to release them, and mount the Units to the DIN Track.

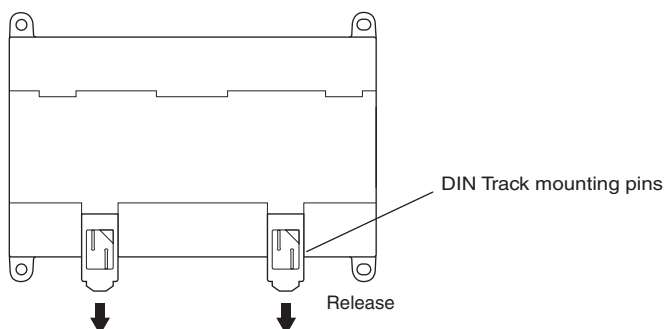

- Fit the back of the Units onto the DIN Track by catching (1) the top of the Units on the Track and then pressing (2) in at the bottom of the Units, as shown below.

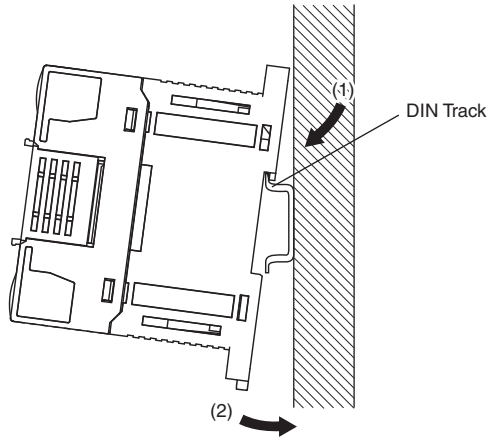

- Press in all of the DIN Track mounting pins to securely lock the Units in place.

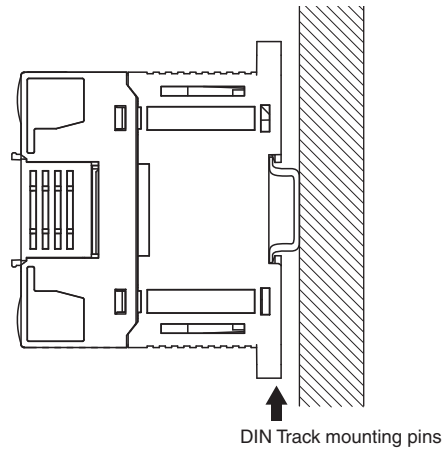

Mounting Brackets

● DIN Track

Secure the DIN Track to the control panel using M4 screws at interval of 210 mm or less (6 holes or fewer). The tightening torque is 1.2 N·m.

PFP-100N2

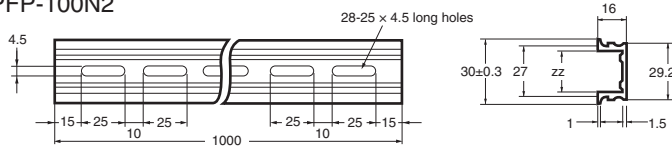

PFP-100N/50N

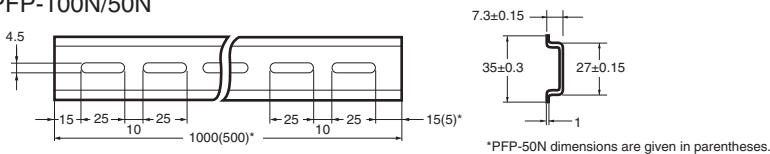

● **End Plate**

Use the PFP-M End Plates to secure the Units so that they do not move towards one end or the other of the DIN Track.

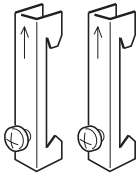

Surface Installation

● **Surface Installation**

- Create the mounting holes in the mounting surface as shown in the dimensions diagrams.
- Align the CP1E CPU Unit with the mounting holes and secure it in place with M4 screws.

● **Surface Installation Mounting Hole Pitch**

- CP1E E30/40/60(S), N30/40/60(S□) or NA20 CPU Units or Expansion I/O Units with 32 or 40 I/O Points

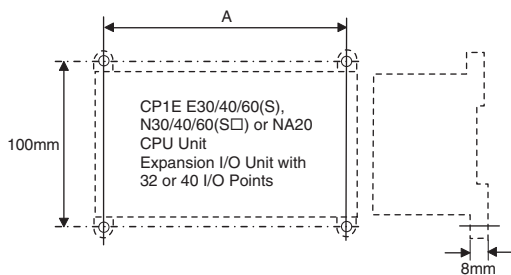

Unit		Mounting hole pitch A (mm)
CP1E CPU Units	E/N30(S□) CPU Unit	120±0.5
	E/N40(S□) CPU Unit	140±0.5
	E/N60(S□) CPU Unit	185±0.5
	NA20 CPU Unit	120±0.5
Expansion I/O Units	Unit with 32 I/O points	140±0.2
	Unit with 40 I/O points	140±0.2

- CP1E E10/14/20(S) or N14/20 CPU Units, Expansion I/O Units with 8, 16, or 20 I/O Points, and Expansion Units

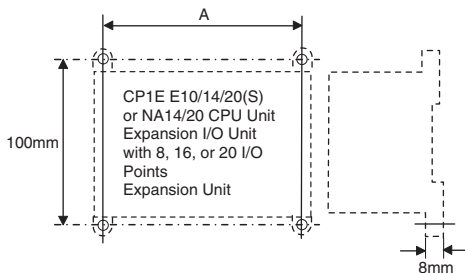

Unit		Mounting hole pitch A (mm)
CP1E CPU Units	E10 CPU Unit	56±0.5
	E/N14(S) CPU Unit	76±0.5
	E/N20(S) CPU Unit	76±0.5
Expansion I/O Units	Unit with 8 input points	56±0.2
	Unit with 8 output points	56±0.2
	Unit with 16 output points	76±0.2
	Unit with 20 I/O points	76±0.2
Analog I/O Units	Analog I/O Analog input Analog output	76±0.2
Temperature Sensor Units	Except CP1W-TS004	76±0.2
	CP1W-TS004	140±0.2

Using Wiring Ducts

Whenever possible, route I/O wiring through wiring ducts. Install the ducts so that it is easy to wire the I/O Units through the ducts. It is handy to have the ducts at the same height as the Racks. Use mounting bases if necessary to adjust the heights.

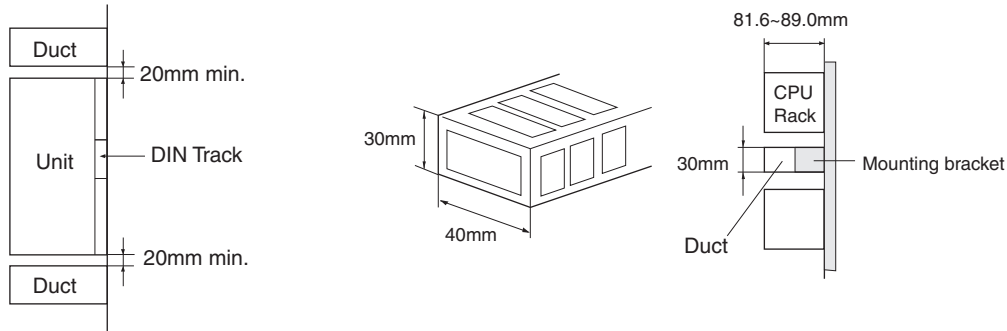

Precautions for Correct Use

Tighten terminal block screws and cable screws to the following torques.

M4: 1.2 N·m

M3: 0.5 N·m

● Routing Wiring Ducts

Install the wiring ducts at least 20 mm between the tops of the Racks and any other objects, (e.g., ceiling, wiring ducts, structural supports, devices, etc.) to provide enough space for air circulation and replacement of Units.

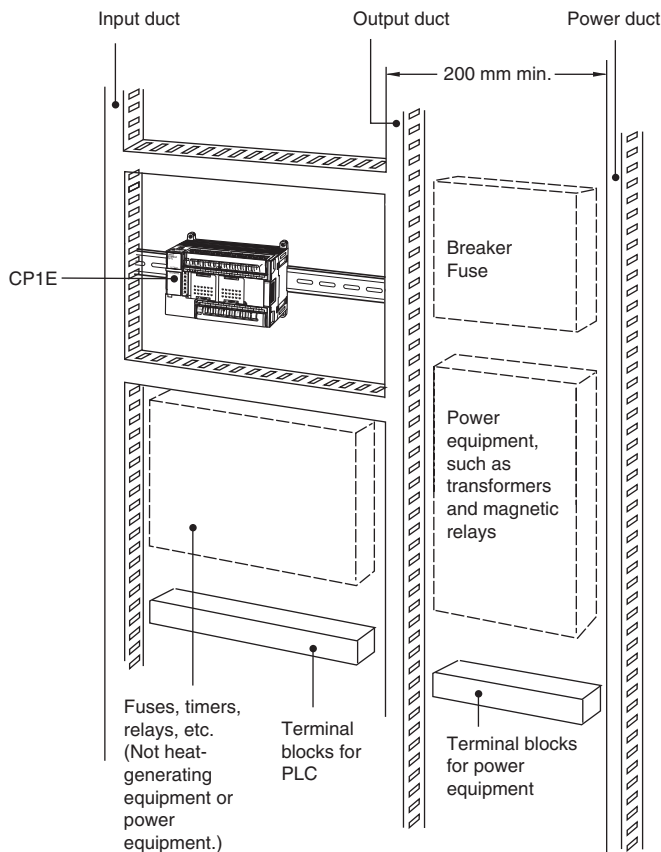

5-2-4 Connecting Expansion I/O Units and Expansion Units

This section describes how to connect Expansion I/O Units and Expansion Units.

Connection Methods

- 1 Remove the cover from the CPU Unit's or the Expansion I/O Unit's expansion connector. Use a flat-head screwdriver to remove the cover from the Expansion I/O Connector.

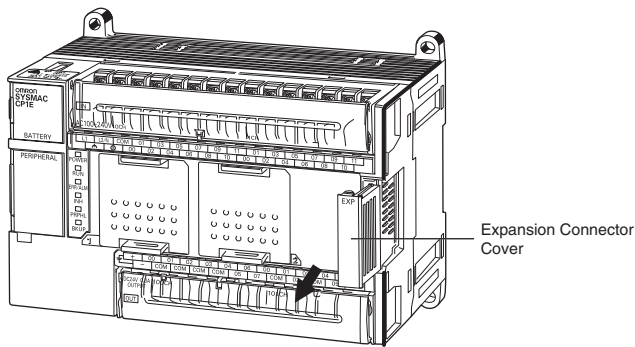

(1) Remove

- 2 Insert the Expansion I/O Unit's connecting cable into the CPU Unit's or the Expansion I/O Unit's expansion connector.

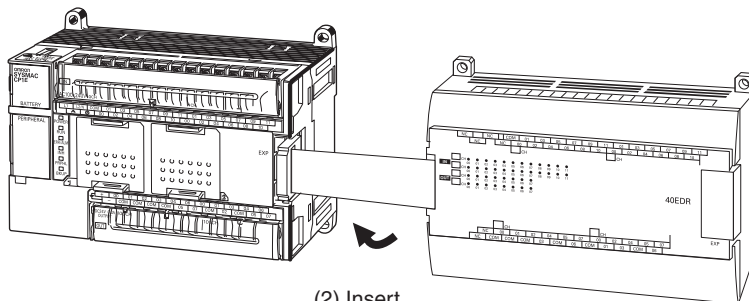

(2) Insert

- 3 Attach the cover to the CPU Unit's or the Expansion I/O Unit's expansion connector.

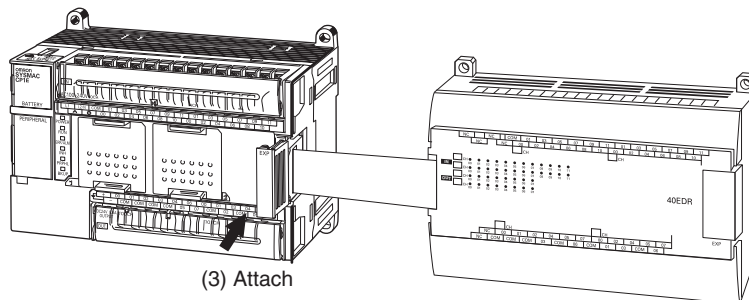

(3) Attach

Precautions on Connecting Units

The following restrictions apply to the CP-series Expansion Units and Expansion I/O Units that can be connected to CP1E CPU Units.

- **Maximum Number of Connectable Units**

With an E30/40/60(S), N30/40/60(S□) or NA20 CPU Unit, a total of up to three Expansion I/O Units and Expansion Units can be connected to one CPU Unit. It is not possible to connect Expansion I/O Units and Expansion Units to E10/14/20(S) or N14/20 CPU Units.

5-3 Wiring

This section describes wiring methods for the CPU Unit.

5-3-1 Wiring Procedure

Make sure that the power supply is OFF before beginning wiring.

1. Prepare the parts required for wiring.	Prepare crimp terminals and cables for wiring.	—
↓		
2. Connect the power supply terminals.	Connect power supply to power supply terminals L1 and L2/N.	Refer to 5-3-2 Wiring Power Supply and Ground Lines.
↓		
3. Ground the ground terminal(\oplus).	Ground to 100 Ω or less.	Refer to 5-3-2 Wiring Power Supply and Ground Lines.
↓		
4. Connect the input terminals.	Connect sensors and switches to the terminals.	Refer to 5-3-3 I/O Wiring.
↓		
5. Connect the output terminals.	Connect loads to the terminals.	Refer to 5-3-3 I/O Wiring.

5-3-2 Wiring Power Supply and Ground Lines

Wiring AC Power Supply and Ground

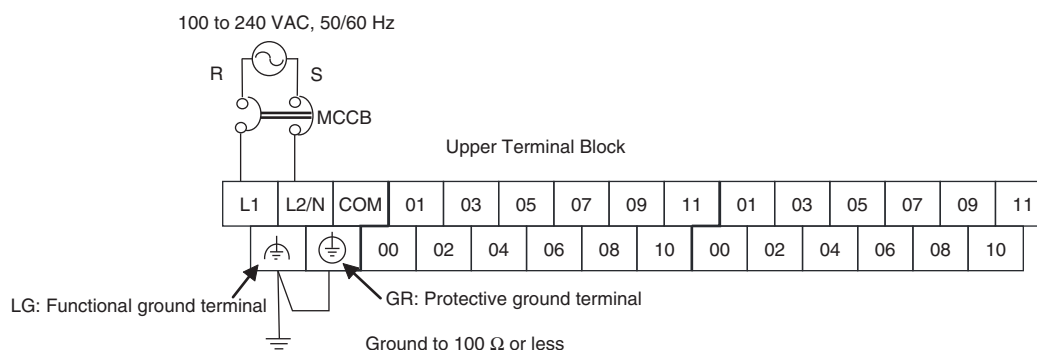

- Wire a separate circuit for the power supply circuit so that there is no voltage drop from the inrush current or startup current that flows when other equipment is turned ON.
- When several CP1E PLCs are being used, it is recommended to wire the PLCs on separate circuits to prevent a voltage drop from the inrush current or incorrect operation of the circuit breaker.

● AC Power Supply Wiring

- Use twisted-pair power supply cables to prevent noise from the power supply lines. Adding a 1:1 isolating transformer reduces electrical noise even further.
- Consider the possibility of voltage drops and the allowable current, and always use thick power lines.
- Use round crimp terminals for AC power supply wiring.



- Use a power supply within the allowable voltage fluctuation range (85 to 264 VAC).

● Grounding

- Always ground the ground terminal to 100 Ω or less to protect against electric shock and incorrect operation from electrical noise.
- If one phase of the power supply is grounded, connect the grounded phase to the L2/N terminal.
- The GR terminal is a ground terminal. To prevent electrical shock, use a dedicated ground line (2 mm² min.) of 100 Ω or less.
- The line ground terminal (LG) is a noise-filtered neutral terminal. If noise is a significant source of errors or if electrical shocks are a problem, connect the line ground terminal (LG) to the ground terminal (GR) and ground both with a ground resistance of 100 Ω or less.
- To prevent electrical shock when short-circuiting between the LG and GR terminals, always use a ground of 100 Ω or less.
- Do not connect ground lines to other devices or to the frame of a building. Doing so will reverse the effectiveness of the ground and instead have a bad influence.

● Isolation Transformer

The PLC's internal noise isolation circuits are sufficient to control typical noise in power supply lines. Ground noise can be further reduced by providing the power supply through a 1:1 isolating transformer. Do not ground the secondary coil of the transformer.

WARNING

Tighten the AC power supply terminal screws to a torque of 0.5 N·m.

Loose screws may result in fire or malfunction.



Precautions for Correct Use

- Loose pieces of wires may fall in the area when wiring. To prevent these pieces from entering into the Unit, leave the label on the top of the Unit while wiring.
- Remove the label after the completion of wiring to ensure proper heat dissipation.
- The power supply terminals are located at the top of the Unit. Do not connect a power supply to the 24-VDC external supply terminals on the bottom of the Unit. Internal circuits may be damaged if power is supplied to these terminals.

Wiring DC Power Supply and Ground

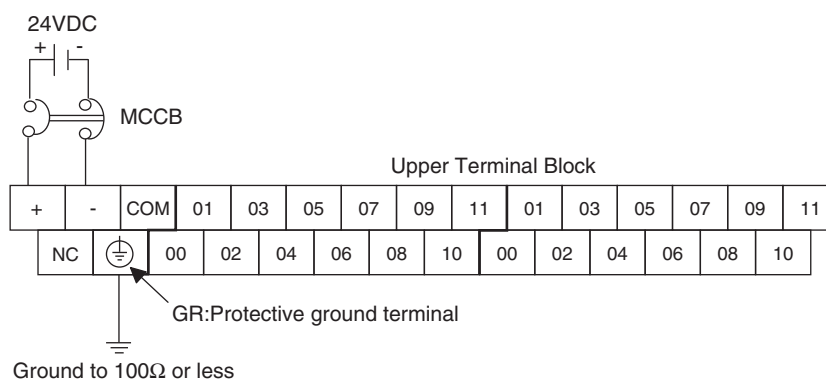

- Wire a separate circuit for the power supply circuit so that there is no voltage drop from the inrush current or startup current that flows when other equipment is turned ON.
- When several CP1E PLCs are being used, it is recommended to wire the PLCs on separate circuits to prevent a voltage drop from the inrush current or incorrect operation of the circuit breaker.

● DC Power Supply Wiring

- Use crimp terminals or solid wire for power supply wiring. Do not connect bare stranded wires directly to terminals.



- M3 self-rising terminal screws are used. Tighten the terminal block screws to the torque of 0.5 N·m.
- Use a power supply within the allowable voltage fluctuation range (20.4 to 26.4 VDC).
- The maximum power consumption is 20 W for N30/40/60(S□) or NA20 CPU Units, 13 W for N14/20 CPU Units, 9W for E10 CPU Units.
- There will be a inrush current of about five times that level when the power is turned ON.

● Grounding

- Always ground the ground terminal to 100Ω or less to protect against electric shock and incorrect operation from electrical noise.
- The GR terminal is a ground terminal. To prevent electrical shock, use a dedicated ground line (2mm² min.) of 100Ω or less.
- Do not connect ground lines to other devices or to the frame of a building. Doing so will reverse the effectiveness of the ground and instead have a bad influence.



Precautions for Safe Use

- Be sure not to reverse the positive and negative leads when wiring the power supply terminals.
- Supply power to all of the Power Supply Units from the same source.
- Use reinforced insulation or double insulation for the DC power supplies connected to DC Power Supply Units to comply with EC(Low Voltage Directive) Directives.



Precautions for Correct Use

- Loose pieces of wires may fall in the area when wiring. To prevent these pieces from entering into the Unit, leave the label on the top of the Unit while wiring.
- Remove the label after the completion of wiring to ensure proper heat dissipation.
- The power supply terminals are located at the top of the Unit.

5-3-3 I/O Wiring

I/O Wiring



Precautions for Safe Use

- Never apply a voltage that exceeds the input voltage for Input Units or the maximum switching capacity for Output Units.
- When the power supply has positive and negative terminals, always wire them correctly.
- Do not bend the I/O Connecting cable past its natural bending radius or pull in it with excessive force. Doing so will damage the cable.

● Wire Sizes

- AWG22 to AWG18 (0.32 to 0.82 mm²) power lines are recommended.
- The current capacity of electric wire depends on factors such as the ambient temperature and insulation thickness, as well as the gauge of the wire.

● Crimp Terminals

- M3 self-rising terminal screws are used.
- Use crimp terminals or solid wire for wiring.
- Do not connect bare stranded wires directly to terminals.
- Tighten the terminal block screws to the torque of 0.5 N·m.
- Use crimp terminals (M3) having the dimensions shown below.



● Wiring

- Wire the Units so that they can be easily replaced.
- Make sure that the I/O indicators are not covered by the wiring.
- Do not place the I/O wiring in the same conduits or ducts as high-voltage or power lines. Inductive noise can cause errors or damage.
- Tighten the terminal screws to the torque of 0.5 N·m.

Unit type	Terminal width	Terminal pitch
CPU Units	6.4mm	7.6mm
Expansion I/O Units 40ED□/32E□/20EDT□	6.4mm	7.7mm
Expansion I/O Units AD04□/DA0□□/MA□□/TS□0□/ SRT21/20EDR1/16E□/8E□	6.8mm	8.4mm

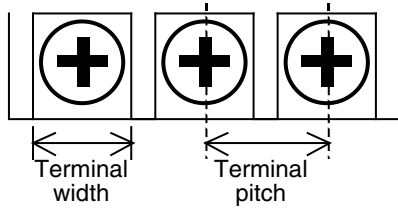

Example of Input Device Connections

Use the following information for reference when selecting or connecting input devices.

● DC Input Units

Connectable DC Input Devices (for DC Output Models)

Contact outputs

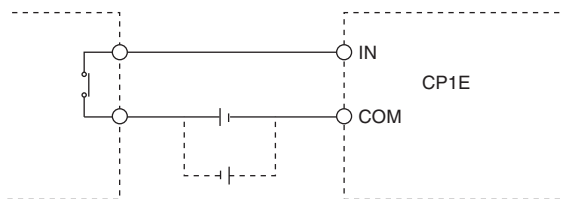

Two-wire, DC outputs

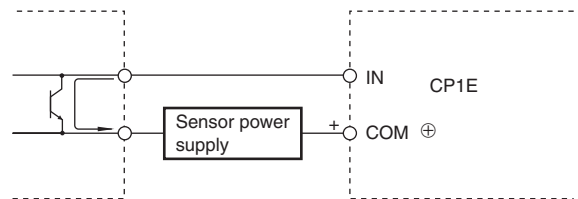

NPN open-collector outputs

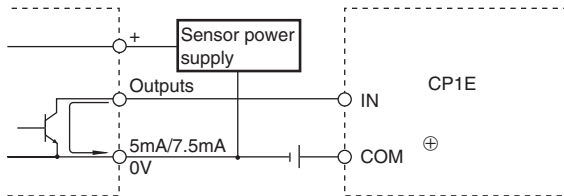

NPN current outputs

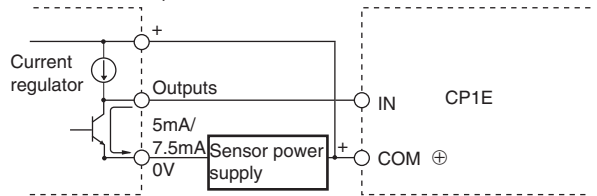

PNP current outputs

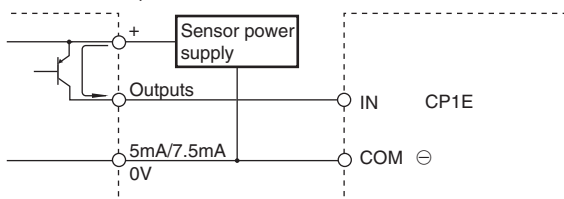

Voltage outputs

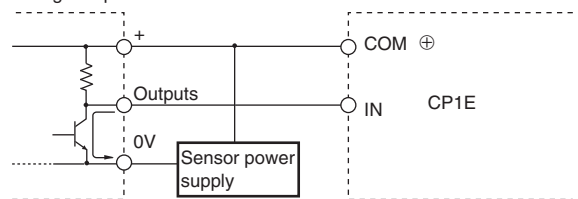

The circuit below should NOT be used for I/O devices having a voltage output.

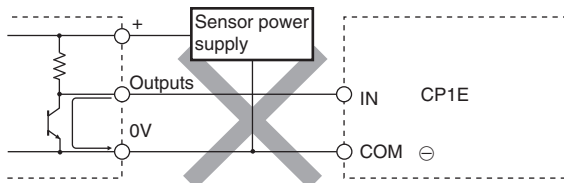

Precautions When Connecting a Two-wire DC Sensor

When using a two-wire sensor with a 24-VDC input device, check that the following conditions have been met. Failure to meet these conditions may result in operating errors.

(1) Relation between voltage when the PLC is ON and the sensor residual voltage:

$$V_{ON} \leq V_{CC} - V_R$$

(2) Relation between current when the PLC is ON and sensor control output (load current):

$$I_{OUT}(\min) \leq I_{ON} \leq I_{OUT}(\max)$$

$$I_{ON} = (V_{CC} - V_R - 1.5[\text{PLC internal residual voltage}]) / R_{IN}$$

When I_{ON} is smaller than $I_{OUT}(\min)$, connect a bleeder resistor R .

The bleeder resistor constant can be calculated as follows:

$$R \leq (V_{CC} - V_R) / (I_{OUT}(\min) - I_{ON})$$

$$\text{Power } W \geq (V_{CC} - V_R)^2 / R \times 4 (\text{allowable margin})$$

(3) Relation between current when the PLC is OFF and sensor leakage current:

$$I_{OFF} \geq I_{leak}$$

Connect a bleeder resistor if I_{leak} is greater than I_{OFF} .

Use the following equation to calculate the bleeder resistance constant.

$$R \leq R_{IN} \times V_{OFF} / (I_{leak} \times R_{IN} - V_{OFF})$$

$$\text{Power } W \geq (V_{CC} - V_R)^2 / R \times 4 (\text{allowable margin})$$

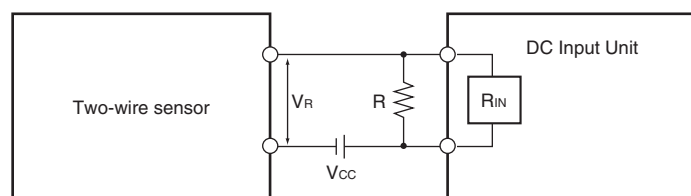

V_{CC} : Power voltage

V_r : Sensor output residual voltage

V_{ON} : PLC ON voltage

I_{OUT} : Sensor control current (load current)

V_{OFF} : PLC OFF voltage

I_{ON} : PLC ON current

I_{leak} : Sensor leakage current

I_{OFF} : PLC OFF current

R : Bleeder resistance

R_{IN} : PLC input impedance

(4) Precautions on Sensor Inrush Current

An incorrect input may occur due to sensor inrush current if a sensor is turned ON after the PLC has started up to the point where inputs are possible.

Determine the time required for sensor operation to stabilize after the sensor is turned ON and take appropriate measures, such as inserting into the program a timer delay after turning ON the sensor.

● Programming Example

In this example, the sensor's power supply voltage is used as the input to CIO 0.00.

A 100-ms timer delay (the time required for an OMRON Proximity Sensor to stabilize) is created in the program.

After the Completion Flag for the timer turns ON, the sensor input on input bit CIO 0.01 will cause output bit CIO 100.00 to turn ON.

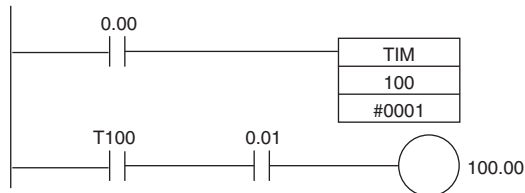

Output Wiring

● Protective Circuit for Load Short-circuits

If a load connected to the output terminals is short-circuited, output components and the printed circuit boards may be damaged. To guard against this, incorporate a fuse in the external circuit. Use a fuse with a capacity of about twice the rated output.

● Connecting to a TTL Circuit

A TTL circuit cannot be connected directly to a transistor output because of the transistor's residual voltage. Connect a TTL Unit through a CMOS-IC. It is necessary to connect a pull-up resistor for a transistor output.

● Precautions on Inrush Current

When connecting a transistor or triac output to a load having a high inrush current (such as an incandescent lamp), steps must be taken to avoid damage to the transistor or triac. Use either of the following methods to reduce the inrush current.

[Method1]

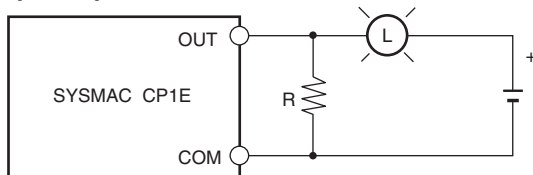

Providing a dark current of approx. one-third of the rated value through an incandescent lamp

[Method2]

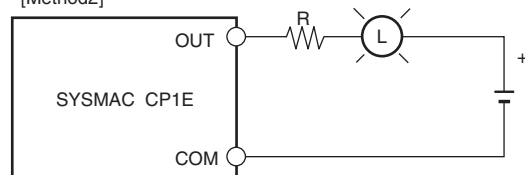

Installing a limiting resistor

5-3-4 Wiring Safety and Noise Controls

I/O Signal Wiring

Whenever possible, place I/O signal lines and power lines in separate ducts or conduits both inside and outside of the control panel.

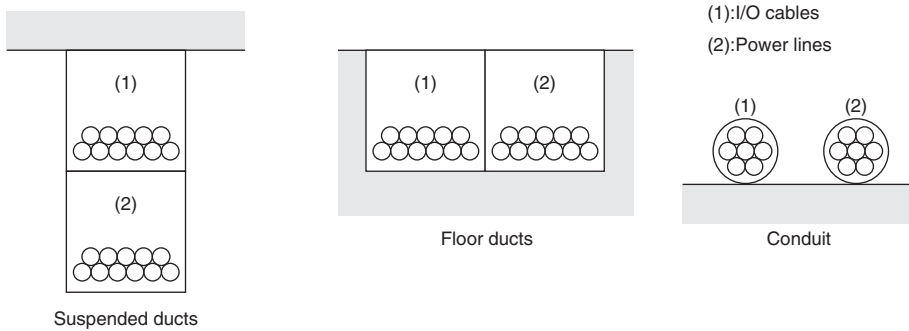

When wiring in the same duct, use shielded cables and connect the shields to the GR terminal to reduce noise.

Inductive Loads

When an inductive load is connected to an I/O Unit, connect a surge protector or diode in parallel with the load as shown below.

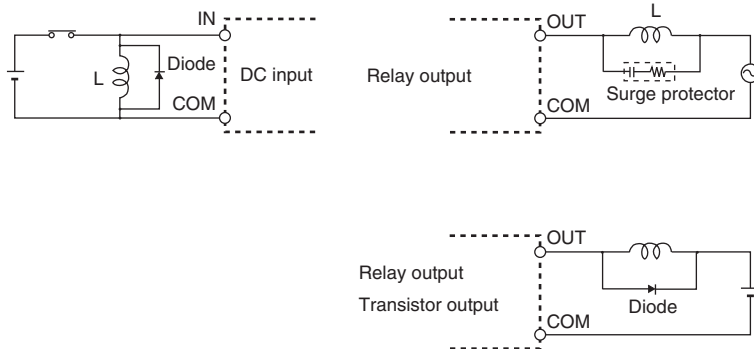

Precautions for Correct Use

Use surge protectors and diodes with the following specifications.

Surge protector	
Resistance	: 50Ω
Capacitor	: 0.47μF
Voltage	: 200V
Diode	
Breakdown voltage	: 3 times load voltage
Mean rectification current	: 1 A

Reducing Electrical Noise for External Wiring

Take the following points into account when externally wiring I/O, power supply, and power lines.

- When multi-conductor signal cable is being used, do not combine I/O wires and other control wires in the same cable.
- If wiring racks are parallel, allow at least 300 mm between them.

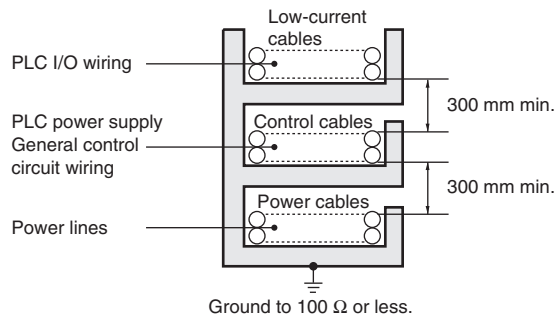

- If the I/O wiring and power cables must be placed in the same duct, they must be shielded from each other using grounded steel sheet metal.

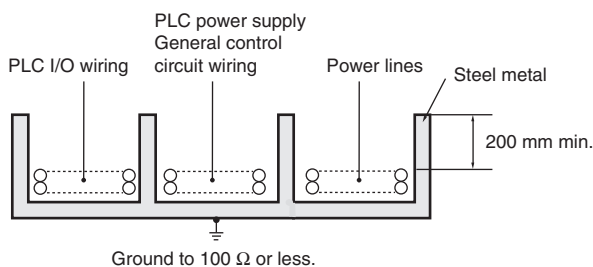

5-3-5 Relay Output Noise Reduction Methods

The CP1E PLCs conform to the Common Emission Standards (EN61131-2) of the EMC Directives. However, noise generated by relay output switching may not satisfy these Standards.

In such a case, a surge protector must be connected to the load side or other appropriate countermeasures must be provided outside the PLC. Countermeasures taken to satisfy the standards vary depending on the devices on the load side, wiring, configuration of machines, etc.

Following are examples of countermeasures for reducing the generated noise.

● Countermeasures (Refer to EN 61131-2 for details.)

- Countermeasures are not required if the frequency of load switching for the whole system with the PLC included is less than 5 times per minute.
- Countermeasures are required if the frequency of load switching for the whole system with the PLC included is more than 5 times per minute.

● Countermeasure Examples

- When switching an inductive load, connect a surge protector, diodes, etc., in parallel with the load or contact as shown below.

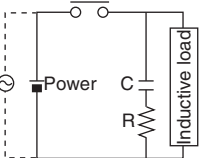
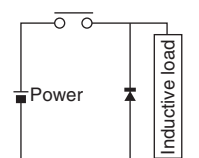
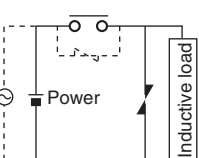
Circuit	Current		Characteristic	Required element
	AC	DC		
<p>CR method</p> 	OK	OK	<p>If the load is a relay or solenoid, there is a time lag between the moment the circuit is opened and the moment the load is reset.</p> <p>If the supply voltage is 24 or 48 V, insert the arc killer in parallel with the load. If the supply voltage is 100 to 200V, insert the arc killer between the contacts.</p>	<p>The capacitance of the capacitor must be 1 to 0.5 μF per contact current of 1 A and resistance of the resistor must be 0.5 to 1 Ω per contact voltage of 1 V.</p> <p>These values, however, vary with the load and the characteristics of the relay.</p> <p>Decide these values from experiments, and take into consideration that the capacitance suppresses spark discharge when the contacts are separated and the resistance limits the current that flows into the load when the circuit is closed again.</p> <p>The dielectric strength of the capacitor must be 200 to 300 V. If the circuit is an AC circuit, use a capacitor with no polarity.</p>
<p>Diode method</p> 	---	OK	<p>The diode connected in parallel with the load changes energy accumulated by the coil into a current, which then flows into the coil so that the current will be converted into Joule heat by the resistance of the inductive load.</p> <p>This time lag, between the moment the circuit is opened and the moment the load is reset, caused by this method is longer than that caused by the CR method.</p>	<p>The reversed dielectric strength value of the diode must be at least 10 times as large as the circuit voltage value. The forward current of the diode must be the same as or larger than the load current.</p> <p>The reversed dielectric strength value of the diode may be two to three times larger than the supply voltage if the surge protector is applied to electronic circuits with low circuit voltages.</p>
<p>Varistor method</p> 	OK	OK	<p>The varistor method prevents the imposition of high voltage between the contacts by using the constant voltage characteristic of the varistor. There is time lag between the moment the circuit is opened and the moment the load is reset.</p> <p>If the supply voltage is 24 or 48 V, insert the varistor in parallel with the load. If the supply voltage is 100 to 200 V, insert the varistor between the contacts.</p>	-

- When switching a load with a high inrush current such as an incandescent lamp, suppress the inrush current as shown below.

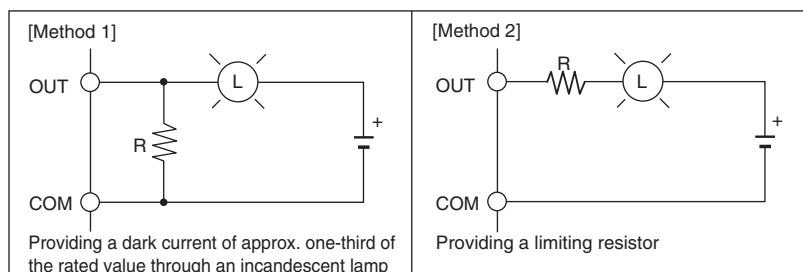

● Conditions for Meeting EMC Directives when Using CP-series Relay Expansion I/O Units

EN61131-2 immunity testing conditions when using the CP1W-40EDR, CP1W-32ER, or CP1W-16ER with a CP1W-CN811 I/O Connecting Cable are given below.

- Recommended Ferrite Core

Ferrite Core (Data Line Filter): 0443-164151 manufactured by Nisshin Electric

Minimum impedance: 90 Ω at 25 MHz, 160 Ω at 100 MHz

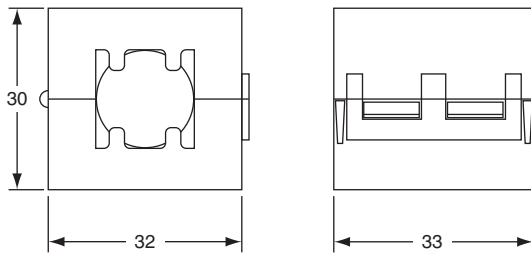

- Recommended Connection Method

(1) Cable Connection Method

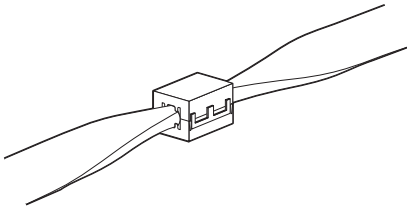

(2) Connection Method

As shown below, connect a ferrite core to each end of the CP1W-CN811 I/O Connecting Cable.

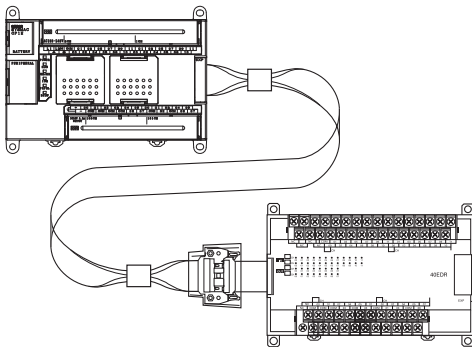

6

Troubleshooting

This section describes how to troubleshoot problems that may occur with a CP1E PLC.

6-1	Troubleshooting CPU Unit Errors	6-2
6-1-1	Errors and Remedies	6-2
6-1-2	Checking Errors	6-2
6-1-3	Checking Detailed Status	6-3
6-1-4	Reading Error Log Information	6-3
6-1-5	Types of Errors	6-5
6-1-6	Error Processing Flowchart	6-6
6-1-7	No Operation When Power Is Supplied	6-7
6-1-8	Fatal Errors	6-7
6-1-9	CPU Errors	6-11
6-1-10	Non-fatal Errors	6-12
6-1-11	Other Errors	6-14
6-2	Troubleshooting Unit Errors	6-15
6-2-1	Inputs	6-15
6-2-2	Outputs	6-16
6-2-3	Built-in Analog	6-17
6-2-4	CX-Programmer Connection	6-18

6-1 Troubleshooting CPU Unit Errors

This section describes how to troubleshoot errors that occur in the CP1E CPU Units.

6-1-1 Errors and Remedies

Use the following procedure when an error occurs.

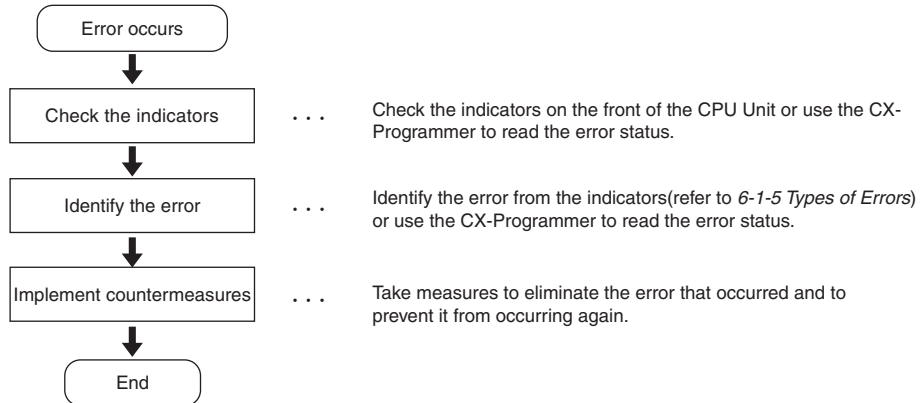

6-1-2 Checking Errors

The type of error that occurred can be determined by checking the indicators on the front of the CPU Unit or by using the CX-Programmer.

Refer to 6-1-5 Types of Errors for details on the types of error status.

Checking the Indicators

● : Not lit ◐ : Flashing ◑ : Lit

Indicator	POWER	RUN	ERR/ALM	INH	PRPHL	BKUP	RS232C	RS485	COMM	Green	Green	Red	Yellow	Yellow	Yellow	Yellow	Yellow	Yellow	Status
POWER ○	◐	◐	◐	◐	◐	◐	◐	◐	◐	◐	◐	◐	◐	◐	◐	◐	◐	◐	Normal operation
RUN ○	◐	◐	◐	◐	◐	◐	◐	◐	◐	◐	●	◐	◐	◐	◐	◐	◐	Operation is stopped in PROGRAM mode	
ERR/ALM ○	◐	◐	◐	◐	◐	◐	◐	◐	◐	◐	◐	●	●	◐	◐	◐	◐		A non-fatal error has occurred
INH ○	◐	◐	◐	◐	◐	◐	◐	◐	◐	◐	◐	◐	◐	◐	◐	◐	◐	A fatal error has occurred	
PRPHL ○	◐	◐	◐	◐	◐	◐	◐	◐	◐	◐	◐	◐	◐	◐	◐	◐	◐		A fatal error has occurred
BKUP ○	◐	◐	◐	◐	◐	◐	◐	◐	◐	◐	◐	◐	◐	◐	◐	◐	◐	A fatal error has occurred	
RS232C ○	◐	◐	◐	◐	◐	◐	◐	◐	◐	◐	◐	◐	◐	◐	◐	◐	◐		A fatal error has occurred
RS485 ○	◐	◐	◐	◐	◐	◐	◐	◐	◐	◐	◐	◐	◐	◐	◐	◐	◐	A fatal error has occurred	
POWER	◐	◐	◐	◐	◐	◐	◐	◐	◐	◐	◐	◐	◐	◐	◐	◐	◐		Normal operation
RUN	◐	◐	◐	◐	◐	◐	◐	◐	◐	◐	◐	◐	◐	◐	◐	◐	◐	Operation is stopped in PROGRAM mode	
ERR/ALM	◐	◐	◐	◐	◐	◐	◐	◐	◐	◐	◐	◐	◐	◐	◐	◐	◐		A non-fatal error has occurred
INH	◐	◐	◐	◐	◐	◐	◐	◐	◐	◐	◐	◐	◐	◐	◐	◐	◐	A fatal error has occurred	
PRPHL	◐	◐	◐	◐	◐	◐	◐	◐	◐	◐	◐	◐	◐	◐	◐	◐	◐		A fatal error has occurred
BKUP	◐	◐	◐	◐	◐	◐	◐	◐	◐	◐	◐	◐	◐	◐	◐	◐	◐	A fatal error has occurred	
RS232C	◐	◐	◐	◐	◐	◐	◐	◐	◐	◐	◐	◐	◐	◐	◐	◐	◐		A fatal error has occurred
RS485	◐	◐	◐	◐	◐	◐	◐	◐	◐	◐	◐	◐	◐	◐	◐	◐	◐	A fatal error has occurred	
COMM	◐	◐	◐	◐	◐	◐	◐	◐	◐	◐	◐	◐	◐	◐	◐	◐	◐		Normal operation
RS485 (N□□S1-type CPU Unit only)	◐	◐	◐	◐	◐	◐	◐	◐	◐	◐	◐	◐	◐	◐	◐	◐	◐	Operation is stopped in PROGRAM mode	

Checking Error Status with the CX-Programmer

Use the following procedure to read the error status.

- 1 Place the CX-Programmer online with the CPU Unit.
- 2 Double-click **Error Log** in the project tree in the main window.

The PLC Errors Window will be displayed. Click the **Errors** Tab. The current errors will be displayed on the Errors Tab Page.

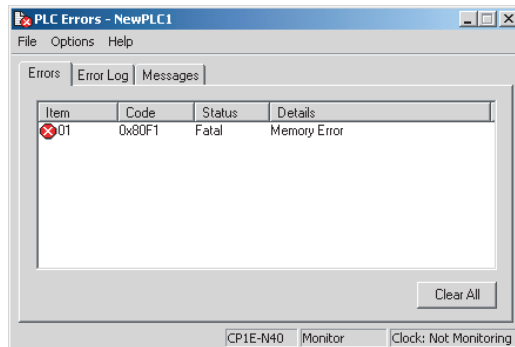

6-1-3 Checking Detailed Status

You can check detailed error status using information registered in the Auxiliary Area.

The following error details are registered.

Area	Description
Error flags	The Auxiliary Area contains flags that indicate the type of error. Error information is provided for various types of error.
Error information	The Auxiliary Area contains words that provide detailed information on current errors. Error information is provided for various types of error.
Error code	The Auxiliary Area contain a word that provides a code that describes the error that has occurred. The error code is stored in A400 for all errors. If two or more errors occur at the same time, the highest (most serious) error code will be stored in A400.

6-1-4 Reading Error Log Information

If the error status could not be checked when the error occurred, it can be checked by reading error log data.

The following information is stored in the error log.

- Error code (This is the same error code as is stored in word A400.)
- Error contents
- Time of occurrence

Error Log Information

A maximum of 20 error records will be stored in the error log.

If more than 20 errors occur, the oldest error record (in A100 to A104) will be deleted and the 19 records stored in A105 to A199 will be shifted by one, with the newest record being stored in A195 to A199.

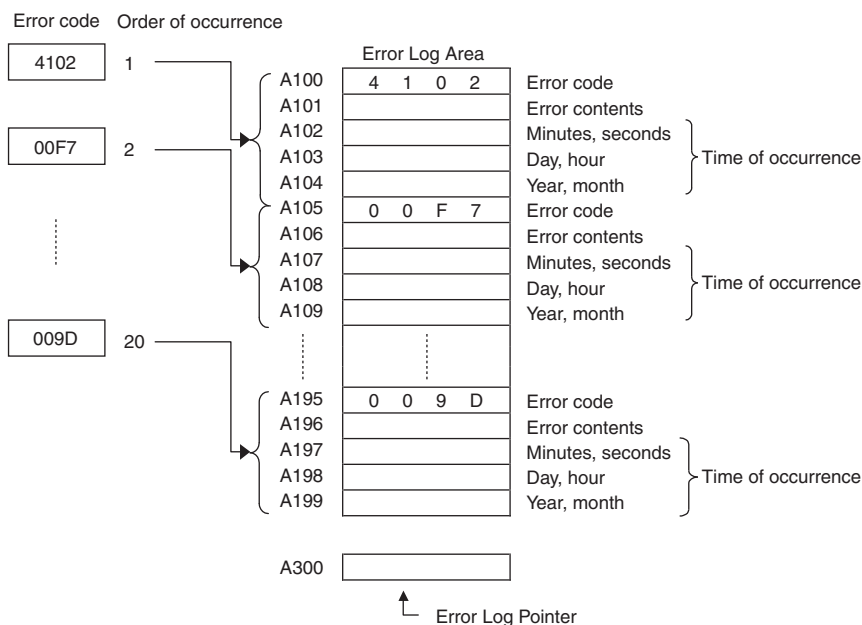

Note CP1E E□□(S)-type CPU Units do not support the clock function, so the time of occurrence cannot be confirmed. The display is always 01-01-01 01:01:01 Sunday.

Checking Error Log Information

The following methods can be used to check error log information with the CX-Programmer.

● CX-Programmer PLC Error Window

Check the error log by clicking the **Error Log** Tab in the PLC Errors Window of the CX-Programmer.

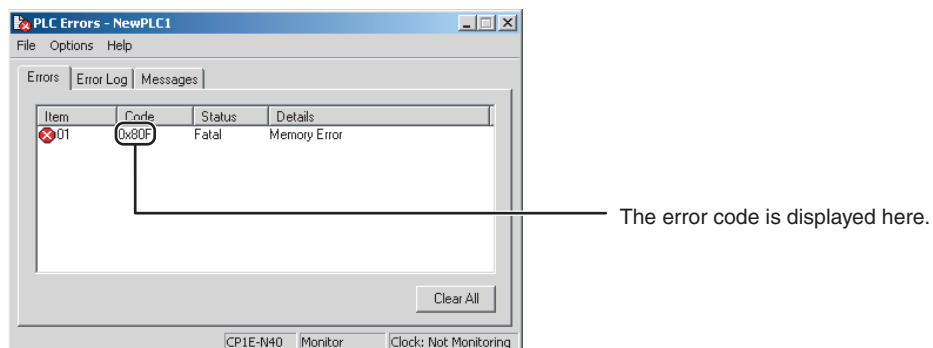

The example above shows that a memory error has occurred.

- Error code 80F1 → Memory error
- Error contents (A403) → 0400 → A403.10 is ON → Backup memory error

● Directly Monitoring the Area where Error Log Information is Stored

- 1 Connect the CX-Programmer online.
- 2 Read words A100 to A199.
- 3 Check the error status from the registered data.

6-1-5 Types of Errors

The type of error that has occurred can be identified by checking the indicators on the front of the CPU Unit, or by using the CX-Programmer to check the error status.

The errors detected by the CPU Unit are listed in the following table.

Refer to 6-2 *Troubleshooting Unit Errors* for errors not detected by the CPU Unit.

- Error code storage word: The error code is stored in A400 when an error occurs.
- Error flags: Flags that indicate the type of error are allocated in the Auxiliary Area.
- Error information: There are words in the Auxiliary Area that provide specific information on the meaning of error flags and information on the error location and error details.

● : Not lit ✕ : Flashing ✕ : Lit

Error	POWER	RUN	ERR/ ALM	INH	PRPHL	BKUP	Built-in RS-232C/ RS-485 communi- cations status	Error code (in A400)	Error flag	Error information		Opera- tion status
										Error	Word	
Power supply error	● Not lit	● Not lit	● Not lit	● Not lit	● Not lit	–	● Not lit	–	–	–	–	Opera- tion stops.
CPU error (WDT error)*1	✕ Lit	● Not lit	✕ Lit	–	–	–	–	–	–	–	–	Opera- tion stops.
Peripheral USB port communications error	✕ Lit	✕ Lit	● Not lit	–	● Not lit	–	–	–	–	–	–	Opera- tion con- tinues.
Built-in RS-232C port/Built-in RS-485 port communi- cations error	✕ Lit	✕ Lit	● Not lit	–	–	–	● Not lit	–	–	–	–	Opera- tion con- tinues.
Fatal errors *1*2	Memory error	✕ Lit	● Not lit	✕ Lit	–	–	–	0x80F1	A401.15	Memory Error Location	A403	Opera- tion stops.
	I/O bus error							0x80CA	A401.14	Always 0x0A0A	A404	
	Too many I/O points error							0x80E1	A401.11	Always 0x4000	A407	
	Program error							0x80F0	A401.09	Program Error Details	A294 to A299	
	Cycle time exceeded error							0x809F	A401.08	–	–	
	FALS error							0xC101 to 0xC2FF	A401.06	–	–	

● : Not lit ◐ : Flashing ○ : Lit

Error	POWER	RUN	ERR/ALM	INH	PRPHL	BKUP	Built-in RS-232C/RS-485 communications status	Error code (in A400)	Error flag	Error information		Operation status
										Error	Word	
Non-fatal errors *2	FAL instruction executed	○ Lit	○ Lit	◐ Flashing	—	—	—	0x4101 to 0x42FF	A402.15	Executed FAL Number	A360 to A391	Operation continues.
	Backup memory error							0x00F1	A315.15	—	—	
	PLC setup error							0x009B	A402.10	—	—	
	Option Board error (N/NA□□-type only)							0x00D2	A315.13	Error Option Board Number	A424	
	Battery error							0x00F7	A402.04	—	—	
	Built-in analog error (NA□□-type only)							0x008A	A315.14	Built-in analog I/O error details	A434	

*1 The indicator status is the same for CPU errors and fatal errors, but they can be distinguished because a Programming Device can be connected when a fatal error occurs, but not when a CPU error occurs.

*2 Refer to 6-1-8 Fatal Errors and 6-1-10 Non-fatal Errors for details on fatal and non-fatal errors.

Note The indicator status shows the status of the errors that have occurred in RUN or MONITOR mode.

6-1-6 Error Processing Flowchart

Confirm the error category by referring to the status of the CPU Unit indicators, investigate the cause for the error in the error tables, and take corrective actions.

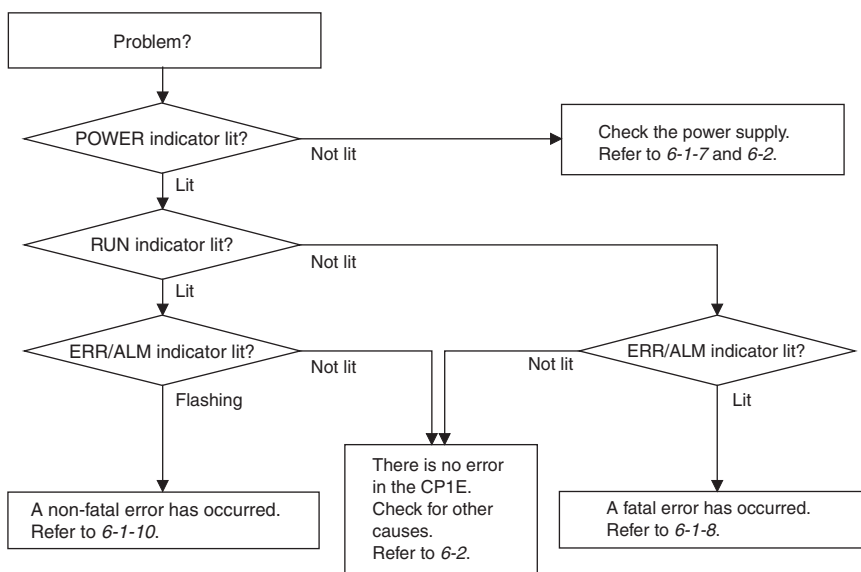

6-1-7 No Operation When Power Is Supplied

First confirm that the POWER indicator (green) is lit.

● POWER Indicator Not Lit

The power supply may not match the Unit rating, wiring may not be correct, or the Unit may be faulty.

- Confirm the Unit rating (i.e., is it 24 VDC or 100 to 240 VAC?) and see if the supply power matches the rating.
- Check the wiring to see if it is correct and that nothing is disconnected.
- Check the voltage at the power supply terminals. If the voltage is normal and the POWER indicator is not lit, the Unit may be faulty. In that case, replace the Unit.

● POWER Indicator Flashing

There may be fluctuations in the power supply voltage, disconnected wiring, or poor contacts. Check the power supply system and wiring.

● POWER Indicator Lit but No Operation

Check the RUN indicator if the POWER indicator is lit but the CPU Unit does not operate.

The CPU Unit may be on standby if the RUN indicator is not lit.

6-1-8 Fatal Errors

● CPU Unit Indicators

● : Not lit ✕ : Flashing ○ : Lit

POWER	○
RUN	●
ERR/ALM	✕
INH	—
PRPHL	—
BKUP	—

—: Irrelevant

There may be a CPU error or a fatal error if operation stops (i.e., the RUN indicator turns OFF) and the ERR/ALM indicator lights.

Data on fatal errors is displayed on the Errors Tab Page of the CX-Programmer's PLC Errors Window.

Take corrective actions after checking error details based on the CX-Programmer display message together with the Auxiliary Area Error Flags and error information.

- Errors are listed in order with the most serious errors first.
 - If two or more errors occur at the same time, the most serious error code will be stored in A400.
 - If the IOM Hold Bit hasn't been turned ON to protect I/O memory, all non-retained areas of I/O memory will be cleared when a fatal error other than FALS occurs.
 - I/O memory will be held when the I/O Memory Hold Bit is ON, but outputs will be turned OFF.

Memory Errors

Cause		Remedy
An error has occurred in memory. One or more bits in A403 will turn ON to indicate where the error has occurred. See below for details. <ul style="list-style-type: none"> Memory Error Location 		See below.
A403.00 is ON	A checksum error has occurred in the ladder program. The power supply was turned OFF when backing up the user program to backup memory.	Transfer the ladder program again.
A403.04 is ON	A checksum error has occurred in the PLC Setup.	Transfer the PLC Setup again.

● Reference

Error flag	Memory Error Flag, A401.15
Error code (A400)	80F1
Error information	Memory Error Location, A403

I/O Bus Error

An I/O bus error has occurred in data transfer between the CPU Units and Units connected to the I/O bus.

Cycle the power supply. If operation is not restored when the power supply has been cycled, turn OFF the power supply and check that connections are proper and that there is no damage.

Cause	Remedy
An error occurred in data transfer between the CPU Unit and an Expansion Unit or Expansion I/O Unit. (A value of 0A0A hex will be stored in A404.)	<ul style="list-style-type: none"> Cycle the power supply. If the problem persists, turn OFF the power supply and check the Connecting Cables between the Units to see if they are connected properly. Check the Unit connections to be sure they are ok (e.g., that there is no damage). After correcting the problem, turn ON the power to the Units again.

● Reference

Error flag	I/O Bus Error Flag, A401.14
Error code (A400)	80CA
Error information	I/O Bus Error Details, A404

Too Many I/O Points Error

The number of CP-series Expansion Units and Expansion I/O Units connected exceeds the restriction for the number of Units or words for the system configuration.

Turn OFF the power supply and reconfigure the system within the restrictions.

Cause	Remedy
The number of CP-series Expansion Units and Expansion I/O Units exceeds the restriction. (A value of 4000 hex will be stored in A407.)	Connect a maximum of three Expansion Units or Expansion I/O Units to N30/40/60(S□) or NA20 CPU Units.

● Reference

Error flag	Too Many I/O Points Flag, A401.11
Error code (A400)	80E1
Error information	Too Many I/O Points Details, A407

Program Errors

A program error indicates a problem with the user program. Refer to the error information, check the program, and correct the mistakes.

Clear the error once the problem has been corrected.

Cause	Remedy
<p>Instruction Processing Error (A295.08 turns ON)</p> <p>The instruction could not be executed because of incorrect operand data, and the ER Flag was turned ON. (Only when the Stop CPU on Instruction Error parameter in the PLC Setup is set to Stop.)</p>	<ul style="list-style-type: none"> Refer to A298 and A299 (instruction program address when the program fails), check the specifications for the relevant instruction, and set the correct operand data. Set the PLC Setup to not stop operation for an instruction error.
<p>Indirect DM Addressing BCD Error (A295.09 turns ON)</p> <p>The operand of indirect DM Area addressing in BCD Mode did not contain a BCD value when the instruction was executed, and the AER Flag was turned ON. (Only when the Stop CPU on Instruction Error parameter in the PLC Setup is set to Stop.)</p>	<ul style="list-style-type: none"> Refer to A298 and A299 (instruction program address when the program fails), and correctly set the content for the indirectly addressed DM operand (BCD mode) to BCD or change the specified destination. Alternatively, change the indirect addressing to binary mode. Set the PLC Setup to not stop operation for an instruction error.
<p>Illegal Area Access Error (A295.10 turns ON)</p> <p>The AER flag is ON because an illegal area was specified for access when executing the instruction. (Only when the Stop CPU on Instruction Error parameter in the PLC Setup is set to Stop.)</p> <p>The following operations are considered illegal access:</p> <ul style="list-style-type: none"> Reading/writing the parameter area Writing to an area without memory installed Writing to a write-protected area Indirect DM addressing BCD error 	<ul style="list-style-type: none"> Refer to A298 and A299 (instruction program address when the program fails) and take corrective actions so that illegal area access errors will not occur. Set the PLC Setup to not stop operation for an instruction error.
<p>No END Error (A295.11 turns ON)</p> <p>This error occurs when there is not an END instruction in the program.</p>	<p>Insert an END instruction at the end of the program allocated to the task stored in A294 (task number when the program fails).</p>
<p>Task Error (A295.12 turns ON)</p> <p>There is no specified interrupt task when an interrupt is generated (input interrupt, high-speed counter interrupt or scheduled interrupt.)</p>	<p>Create a task for the number stored in A294 (task number when the program fails).</p>
<p>Differentiation Overflow Error (A295.13 turns ON)</p> <p>Differentiation instructions were repeatedly inserted or deleted using the online editor and the system restriction was exceeded.</p>	<p>Change the operating mode to PROGRAM mode and then return to MONITOR mode.</p>
<p>Illegal Instruction Errors (A295.14 turns ON)</p> <p>Execution of an unexecutable instruction was attempted.</p>	<p>Transfer the program again using the CX-Programmer.</p>
<p>UM Overflow Error (A295.15 turns ON)</p> <p>An attempt was made to execute a program that exceeds the user program capacity.</p>	<p>Transfer the program again using the CX-Programmer.</p>

● Reference

Error flag	Program Error Flag, A401.09
Error code (A400)	80F0
Error information	Program Error Details, A294 to A299

Cycle Time Exceeded Error

Cause	Remedy
This error occurs when the cycle time PV exceeds the maximum cycle time set in the PLC Setup.	<ul style="list-style-type: none"> • Change the program to reduce the cycle time. • Change the maximum cycle time setting. • Refer to the Maximum Interrupt Task Processing Time (A440) and study the maximum cycle time. For example, use the JUMP instruction to skip sections that are not executed to shorten the cycle time. • The cycle time exceeded error may occur during the following situation in the use of high-speed counter. Please check the input signal of high-speed counter. <ul style="list-style-type: none"> • The Z-signal is input at high-frequency. • Change the direction of signal at high-frequency. • Change the direction of target matching at high-frequency.

● Reference

Error flag	Cycle Time Too Long Error, A401.08
Error code (A400)	809F
Error information	–

Errors Created with FALS Instructions

Cause	Remedy
FALS instruction executed (fatal error) in the program.	<p>C100 hex will be added to the FALS number (001 to 1FF hex) and the result will be stored in A400 as the error code (C100 to C2FF hex).</p> <p>Check the conditions for executing FALS instructions and remove any causes for the user-defined error.</p>

● Reference

Error flag	FALS Error Flag, A401.06
Error code (A400)	C101 to C2FF
Error information	–

6-1-9 CPU Errors

● CPU Unit Indicators

● : Not lit ✕ : Flashing ○ : Lit

POWER	○
RUN	●
ERR/ALM	✕
INH	—
PRPHL	—
BKUP	—

—: Irrelevant

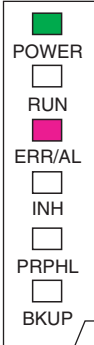

A CPU error or fatal error may have occurred if the ERR/ALM indicator lights during operation (RUN mode or MONITOR mode), the RUN indicator turns OFF, and operation stops.

CPU Unit Errors

Cause	Remedy
A WDT (watchdog) error occurred in the CPU Unit. (This does not occur in normal use.)	Cycle the power supply. The Unit may be faulty. Consult your OMRON representative.

● Reference

Error flag	—
Error code (A400)	—
Error information	—

Note Just as when a CPU error occurs, the RUN indicator will turn OFF and the ERR/ALM indicator will light when a fatal error occurs. Connecting the CX-Programmer, however, is possible for fatal errors but not for CPU errors.

If the CX-Programmer cannot be connected (online), a CPU error has probably occurred.

6-1-10 Non-fatal Errors

A non-fatal error has occurred if both the RUN indicator is lit and the ERR/ALM indicator is flashing during operation (i.e., in RUN or MONITOR mode).

● CPU Unit Indicators

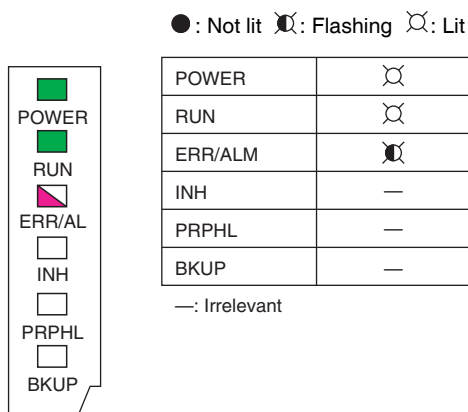

Information on the non-fatal errors can be obtained from the Errors Tab Page of the CX-Programmer's PLC Errors Window.

Take corrective actions after checking error details using the display messages and the Auxiliary Area Error Flags and error information.

- Errors are listed in order with the most serious errors first.
- If two or more errors occur at the same time, the most serious error code will be stored in A400.

Errors Created with FAL Instructions

Cause	Remedy
<p>A FAL instruction was executed in the program to create a non-fatal error.</p> <p>(The executed FAL number 001 to 511 will be stored in A360 to A391. The number 4 will be added to the front of 101 to 2FF (which correspond to executed FAL numbers 001 to 511) and the result will be stored in A400 as error code 4101 to 42FF.)</p>	<p>Check the conditions for executing FAL instructions and remove any causes of the user-defined error.</p>

● Reference

Error flag	FAL Error Flag, A402.15
Error code (A400)	4101 to 42FF
Error information	—

Backup Memory Error

Cause	Remedy
<p>Writing to the backup memory (built-in EEPROM) fails.</p> <p>(A315.15 will turn ON.)</p>	<p>Replace the CPU Unit when the backup memory (built-in EEPROM) has been written to more than 100,000 times.</p>

● Reference

Error flag	Backup Memory Error Flag, A315.15
Error code (A400)	00F1
Error information	—

PLC Setup Errors

Cause	Remedy
A set value error occurred in the PLC Setup.	Correct the PLC Setup with correct values.

● Reference

Error flag	PLC Setup Error Flag, A402.10
Error code (A400)	009B
Error information	—

Option Board Errors (Only for N/NA□□-type CPU Units)

Cause	Remedy
The Option Board is removed while the power is being supplied. (A315.13 will turn ON.)	Turn OFF the power supply and then install the Option Board again.

● Reference

Error flag	Option Board Error Flag, A315.13 Other Non-fatal Error Flag, A402.00
Error code (A400)	00D1
Error information	—

Battery Errors

Cause	Remedy
If the PLC Setup is set to detect battery errors, this error will occur when there is an error in the battery in the CPU Unit (i.e., the voltage is low or a battery is not mounted).	Check the battery connections. Select the <i>Do not detect battery error</i> Check Box in the PLC Setup setting if battery-free operation is being used.

● Reference

Error flag	Battery Error Flag, A402.04
Error code (A400)	00F7
Error information	—

Built-in Analog Errors (Only for NA-type)

Cause	Remedy
For NA-type, when a built-in analog I/O error occurs.	Restart the PLC .If this error still exists, please change unit.

● Reference

Error flag	Built-in analog error, A315.14 Other error flag, A402.00
Error code	008A
Error information	Built-in analog I/O error details, A434

6-1-11 Other Errors

Communications Errors

● CPU Unit Indicators

● : Not lit ⦿ : Flashing ☒ : Lit

POWER	☒
RUN	☒
ERR/ALM	—
INH	—
PRPHL	●
BKUP	—

—: Irrelevant

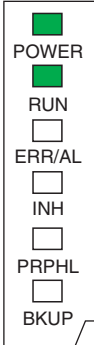

Cause	Remedy
An error has occurred in the communications between the peripheral USB port and connected device.	<ul style="list-style-type: none"> • Check the cable wiring. • Check the USB cable and replace it if necessary.
An error has occurred in the communications between the serial port and connected device.	<ul style="list-style-type: none"> • Confirm that the serial port 1/2 settings in the PLC Setup are correct. • Check the cable wiring. • If a host computer is connected, check the serial port settings and program in the host computer.
An error will be occurred if the cycle time is too long.	<ul style="list-style-type: none"> • Start the CX-Programmer. Select Change Model from the PLC Menu. The Change PLC Dialog Box will be displayed. • Click the Settings Button on the right side of Network Type. The Network Settings [USB] Dialog Box will be displayed. • Click the Network Tab and increase the value in Response Timeout(s).

6-2 Troubleshooting Unit Errors

This section describes how to troubleshoot errors that occur in devices other than the CP1E CPU Unit.

6-2-1 Inputs

No.	Symptom	Cause	Remedy
1	Not all inputs turn ON or indicators are not lit.	1. External power is not supplied for the input.	Supply power.
		2. Supply voltage is low.	Adjust supply voltage to within rated range.
		3. Terminal block screws are loose.	Tighten screws.
2	Not all inputs turn ON even though the indicator is lit.	Input circuit is faulty. (There is a short at the load or something else that caused an overcurrent to flow.)	Replace Unit.
3	Not all inputs turn OFF.	Input circuit is faulty.	Replace Unit.
4	Specific input bit does not turn ON.	1. Input device is faulty.	Replace input devices.
		2. Input wiring disconnected.	Check input wiring
		3. Terminal block screws are loose.	Tighten screws.
		4. Too short ON time of external input.	Adjust input device.
		5. Input circuit is faulty.	Replace Unit.
5	Specific input bit does not turn OFF.	1. Input circuit is faulty.	Replace Unit.
		2. Input bit number is used for output instruction.	Correct the ladder program.
6	Input irregularly turns ON/OFF.	1. External input voltage is low or unstable.	Adjust external input voltage to within rated range.
		2. Malfunction due to noise.	Take protective measures against noise, such as: <ul style="list-style-type: none"> • Install surge suppressor. • Install insulation transformer. • Install shielded cables between the Input Unit and the loads.
		3. Terminal block screws are loose.	Tighten screws.
7	Error occurs in units of 8 points or 16 points, i.e., for the same common	1. Common terminal screws are loose.	Tighten screws.
		2. Faulty data bus	Replace Unit.
		3. Faulty CPU	Replace CPU Unit.
8	Input indicator is not lit in normal operation.	Faulty indicator or indicator circuit.	Replace Unit.

6-2-2 Outputs

No.	Symptom	Cause	Remedy
1	Not all outputs turn ON	1. Load is not supplied with power.	Supply power.
		2. Load voltage is low.	Adjust voltage to within rated range.
		3. Terminal block screws are loose.	Tighten screws.
		4. Unit failure caused by an overcurrent (possibly caused by a short at the load).	Replace Unit.
		5. Faulty I/O bus connector contact.	Replace Unit.
		6. Faulty output circuit.	Replace Unit.
		7. If the INH indicator is lit, the Output OFF Bit (A500.15) is ON.	Turn A500.15 OFF.
2	Not all outputs turn OFF	Output circuit is faulty.	Replace Unit.
3	Output of a specific bit number does not turn ON and indicator is not lit	1. Output ON time is too short because of a mistake in programming.	Correct program to increase the time that the output is ON.
		2. Bit status controlled by multiple instructions in a ladder program.	Correct program so that each output bit is controlled by only one instruction.
		3. Faulty output circuit.	Replace Unit.
4	Output of a specific bit number does not turn ON (indicator lit).	1. Faulty output device.	Replace output device.
		2. Break in output wiring.	Check output wiring.
		3. Loose terminal block screws.	Tighten screws.
		4. Faulty output bit (relay output only).	Replace Unit.
		5. Faulty output circuit.	Replace Unit.
5	Output of a specific bit number does not turn OFF (indicator is not lit).	1. Faulty output bit (relay output only).	Replace Unit.
		2. Bit does not turn OFF due to leakage current or residual voltage.	Replace external load or add dummy resistor.
6	Output of a specific bit number does not turn OFF (indicator lit).	1. Bit status controlled by multiple instructions in ladder program.	Correct the ladder program.
		2. Faulty output circuit.	Replace Unit.
7	Output irregularly turns ON/OFF.	1. Low or unstable load voltage.	Adjust load voltage to within rated range.
		2. Bit status controlled by multiple instructions in ladder program.	Correct program so that each output bit is controlled by only one instruction.
		3. Malfunction due to noise.	Take protective measures against noise, such as: <ul style="list-style-type: none"> • Install surge protector. • Install insulation transformer. • Use shielded cables between the output terminal and the load.
		4. Terminal block screws are loose.	Tighten screws.
8	Error occurs in units of 8 points or 16 points, i.e., for the same common.	1. Common terminal screws are loose.	Tighten screws.
		2. An overcurrent (possibly caused by a short at the load) resulted in a blown fuse for the output.	Replace Unit.
		3. Faulty data bus	Replace Unit.
		4. Faulty CPU	Replace CPU Unit.
9	Output indicator does not light during normal operation.	Faulty indicator.	Replace Unit.

6-2-3 Built-in Analog

No.	Symptom	Cause	Remedy
1	ERR/ALM indicator is lit.	A non-fatal error has occurred.	Refer to 6-1-10.

● Analog Input

No.	Symptom	Cause	Remedy
1	Conversion data does not change.	1. The input is not set for being used.	Check PLC setup, set analog input to "Use" and restart CP1E CPU Unit.
		2. The input wiring is wrong.	Correct wiring according to 3-1-3.
		3. The input device is not working.	Using a tester, check to see if the input voltage or current is changing.
		4. there is a disconnection.	Check A434.00 (AD0) or A434.01 (AD1) flug (open-circuit disconnection.)
2	Value does not change as intended.	1. The input signal range setting is wrong.	Correct the input signal range setting and restart CP1E CPU Unit.
		2. The input device's signal range does not match the input signal range for the relevant input number at the CP1E CPU Unit.	Check the specifications of the input device, match the settings for the input signal ranges and restart CP1E CPU Unit.
		3. When using the 4 mA to 20 mA range, the VIN and I IN terminal is not shorten.	Short VIN and I IN terminal.
3	Conversion values are inconsistent	The input signals are being affected by external noise.	Insert a 0.01- μ F to 0.1- μ F ceramic capacitor or film capacitor between the input's VIN/I IN and COM terminals.
			Use averaging function.

● Analog Output

No.	Symptom	Cause	Remedy
1	Analog output does not change.	1. The output is not set for being used.	Check PLC setup, set analog output to "Use" and restart CP1E CPU Unit.
		2. The conversion value is set outside of the permissible range.	Set the data within the range. Resolution: 1/6000 -10 to 10V: F448 to 0BB8 Hex Other ranges: 0000 to 1770 Hex Resolution: 1/12000 -10 to 10V: E890 to 1770 Hex Other ranges: 0000 to 2EE0 Hex
2	Output does not change as intended.	1. The output signal range setting is wrong.	Correct the output signal range setting and restart CP1E CPU unit.
		2. The Analog I/O specifications of the output device do not match those of the CP1E CPU Unit (e.g., input signal range, input impedance).	Change the output device.
3	Outputs are inconsistent.	The output signals are being affected by external noise.	Try changing the shielded cable connection (e.g., the grounding at the output device).

6-2-4 CX-Programmer Connection

Use the following procedure if the CX-Programmer cannot connect to the PLC.

Connecting via the Peripheral USB Port

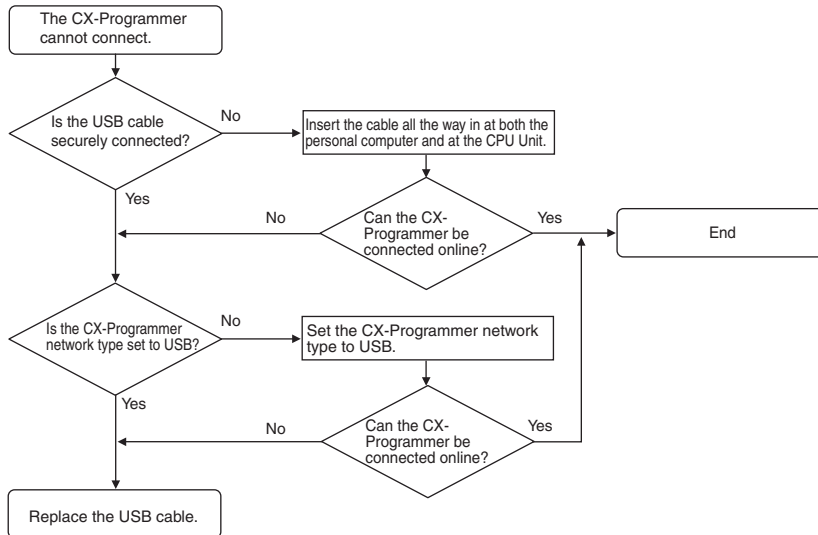

If the cycle time is too long, it may result the communication failure when CX-Programmer tries to work online. In this case, click **the Settings** button on the right side of Network Type in the **Change PLC** dialog box and increase the value in **Response Timeout(s)**.

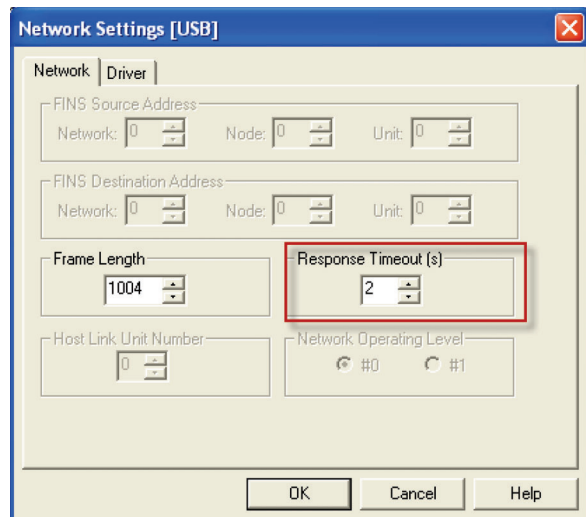
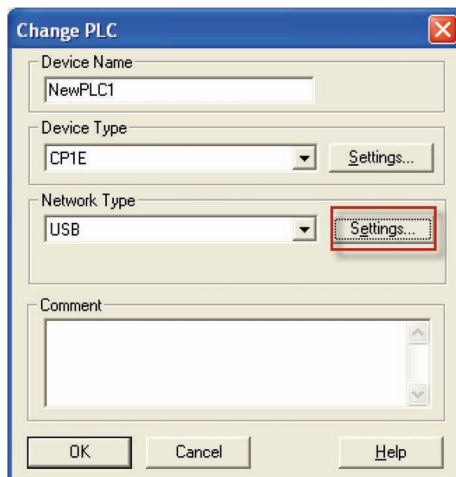



Maintenance and Inspection

This section describes periodic inspections, the service life of the Battery, and how to replace the Battery.

7-1	Periodic Maintenance and Inspection	7-2
7-1-1	Tools Required for Inspections	7-2
7-1-2	Periodic Inspection	7-2
7-1-3	Inspection and Maintenance	7-3
7-1-4	Unit Replacement Precautions	7-4
7-2	Replacing the Battery in N/NA□□(S□)-type CPU Units	7-5

7-1 Periodic Maintenance and Inspection

This section describes periodic inspections and maintenance of CP1E PLCs.

Daily or periodic inspections are required in order to maintain the PLC's functions in peak operating condition.

7-1-1 Tools Required for Inspections

● Required Tools

- Phillips screwdrivers
- Voltage tester or digital voltmeter
- Industrial alcohol and clean cotton cloth

● Tools Required Occasionally

- Synchroscope
- Oscilloscope with pen plotter
- Thermometer and hygrometer (humidity meter)

7-1-2 Periodic Inspection

Although the major components in CP-series PLCs have an extremely long life time, they can deteriorate under improper environmental conditions. Periodic inspections are thus required to ensure that the required conditions are being kept.

Inspection is recommended at least once every six months to a year, but more frequent inspections will be necessary in adverse environments.

Take immediate steps to correct the situation if any of the conditions in the following table are not met.

● Battery

Item	Life	Remedy
Check whether the Battery has reached its service life (CP1W-BAT01 Battery).	Service life expectancy is 5 years at 25°C, less at higher temperatures. (From 1.5 to 5 years depending on model and ambient temperature.)	Replace the Battery when its service life has passed even if a Battery error has not occurred. The service life depends on the model and ambient temperature. Refer to 7-2 <i>Replacing the Battery in N/NA□□(S□)-type CPU Units.</i>

7-1-3 Inspection and Maintenance

No.	Inspection points	Inspection	Criteria	Remedy
1	Power supply voltage	Check for voltage fluctuations at the power supply terminals.	Allowable voltage range AC power supply: 85 to 264 VAC DC power supply: 20.4 to 26.4 VDC	Use a voltage tester to check the power supply at the terminals. Take necessary steps to bring voltage fluctuations within limits.
2	I/O power supply	Check for voltage fluctuations at the I/O terminals.	Voltages must be within I/O specifications for each Unit.	Use a voltage tester to check the power supply at the terminals. Take necessary steps to bring voltage fluctuations within limits.
3	Ambient environment	Check the ambient temperature. (Inside the control panel if the PLC is in a control panel.)	0 to 55°C	Use a thermometer to check the temperature and make sure that the ambient temperature remains within the allowed range of 0 to 55°C.
		Check the ambient humidity (inside the control panel if the PLC is in a control panel).	Relative humidity must be 10% to 90% with no condensation.	Use a hygrometer to check the operation humidity and ensure that the ambient humidity remains between 10% and 90%. Make sure that condensation does not occur due to rapid changes in temperature.
		Check that the PLC is not in direct sunlight.	Not in direct sunlight	Protect the PLC if necessary.
		Check for accumulation of dirt, dust, salt, metal filings, etc.	No significant accumulation	Clean and protect the PLC if necessary.
		Check for water, oil, or chemical spray.	No spray on the PLC	Clean and protect the PLC if necessary.
		Check for corrosive or flammable gases in the area of the PLC.	No corrosive or flammable gases	Check by smell or use a sensor.
		Check the level of vibration or shock.	Vibration and shock must be within specifications.	Install cushioning or shock absorbing equipment if necessary.
Check for noise sources near the PLC.	No significant noise sources	Either separate the PLC and noise source or protect the PLC.		
4	Installation and wiring	Check that the Option Boards and cable connectors are fully inserted and locked.	No looseness	Correct any improperly installed connectors.
		Check for loose screws in external wiring.	No looseness	Tighten loose screws with a Phillips screwdriver.
		Check crimp connectors in external wiring.	Adequate spacing between connectors	Check visually and adjust if necessary.
		Check for damaged external wiring cables.	No damage	Check visually and replace cables if necessary.

7-1-4 Unit Replacement Precautions

Check the following when replacing any faulty Units discovered during inspections.

- Do not replace a Unit until the power is turned OFF.
- Check the new Unit to make sure that there are no errors.
- If a faulty Unit is being returned for repair, describe the problem in as much detail as possible, enclose this description with the Unit, and return the Unit to your OMRON representative.
- For poor contact, take a clean cotton cloth, soak the cloth in industrial alcohol, and carefully wipe the contacts clean. Be sure to remove any lint prior to remounting the Unit.



Precautions for Correct Use

When replacing a CPU Unit, be sure that not only the user program but also all other data required for operation is transferred to or set in the new CPU Unit before starting operation, including DM Area and HR Area settings.

If data area and other data are not correct for the user program, unexpected accidents may occur.

7-2 Replacing the Battery in N/NA□□(S□)-type CPU Units

For CP1E N/NA□□(S□)-type CPU Units, the data in the following areas may be unstable when the power is turned ON.

Mount the CP1W-BAT01 Battery (sold separately) to an N/NA□□(S□)-type CPU Unit if data in the following areas need to be retained after a power interruption.

- DM Area (D) (excluding words backed up to the EEPROM using the DM backup function)
- Holding Area (H)
- Counter Present Values and Completion Flags (C)
- Auxiliary Area related to clock function (A)

A Battery cannot be mounted to an E□□(S)-type CPU Unit.

The procedure to replace the Battery on an N/NA□□(S□)-type CPU Unit is given below.

Battery Service Life and Replacement Period

At 25°C, the maximum service life for the Battery is five years whether or not power is supplied to the CPU Unit while the Battery is installed.

The Battery's lifetime will be shorter when it is used at higher temperatures.

The following table shows the approximate minimum lifetimes and typical lifetimes for the backup Battery (total time with power not supplied).

Model number	Approx. maximum lifetime	Approx. minimum lifetime*	Typical lifetime*
CP1E-N□□□D□-□ CP1E-NA□□D□-□	5 years	13,000 hours (1.5 years)	43,000 hours (5 years)

* The minimum lifetime is the memory backup time at an ambient temperature of 55°C. The typical lifetime is the memory backup time at an ambient temperature of 25°C.

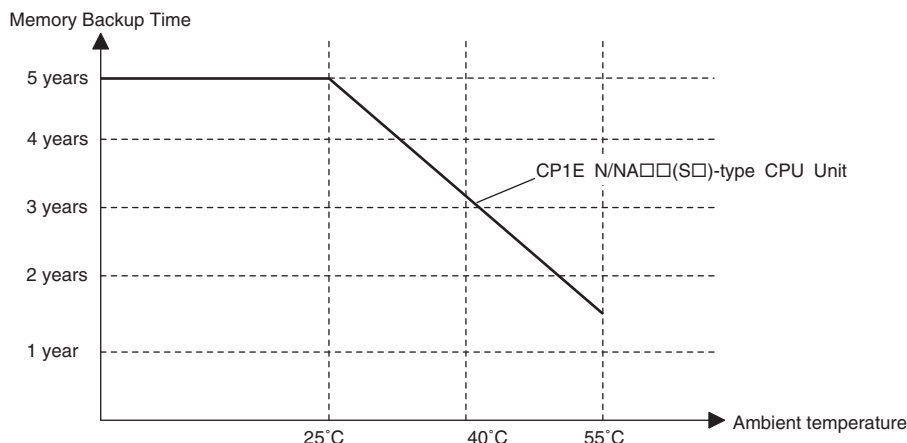

* This graphic is for reference only.

Low Battery Indications

The ERR/ALM indicator on the front of the CPU Unit will flash when the Battery is nearly discharged.

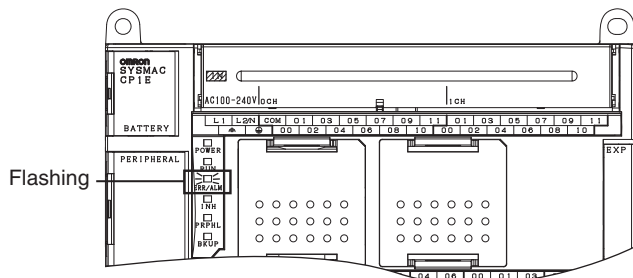

When the ERR/ALM indicator flashes, connect the CX-Programmer to the peripheral USB port and read the error messages.

If a low Battery message appears on the CX-Programmer or the Battery Error Flag (A402.04) is ON, first check whether the Battery is properly connected to the CPU.

If the Battery is properly connected, replace the Battery as soon as possible.

Once a low battery error has been detected, it will take 5 days (at an ambient temperature of 25°C) before the Battery fails assuming that power has been supplied at least once a day.

You can prevent losing data in the RAM by ensuring that the CPU Unit power is not turned OFF until the Battery is replaced.



Precautions for Correct Use

- The low battery message will appear on the CX-Programmer and the Battery Error Flag (A402.04) will turn ON only if the Detect Low Battery parameter in the PLC Setup has been set to detect a low-Battery error.
If this setting has not been made, Battery errors will not be detected.
- The Battery will discharge faster at higher temperatures, e.g., 4 days at 40°C and 2 days at 55°C.

● Replacement Battery

Name: Battery Set

Model: CP1W-BAT01



Precautions for Correct Use

Be sure to install a replacement Battery within two years of the production date shown on the Battery's label.

Production Date



Manufactured in March 2009.

Replacing the Battery

Use the following procedure to replace the Battery when the previous Battery has become completely discharged.



Precautions for Safe Use

We recommend replacing the Battery with the power OFF to prevent the CPU Unit's sensitive internal components from being damaged by static electricity. The Battery can be replaced without turning OFF the power supply. To do so, always touch a grounded piece of metal to discharge static electricity from your body before starting the procedure.

After replacing the Battery, connect a Programming Device and clear the Battery error.

- 1 Turn OFF the power supply to the N/NA□□(S□)-type CPU Unit.
If the CPU Unit has not been ON, turn it ON for at least 30 minutes and then turn it OFF.



Additional Information

There is a capacitor inside the N/NA□□(S□)-type CPU Unit that backs up memory when the Battery is removed. If power is not turned ON for at least 30 minutes before replacing the Battery, the capacitor will not be fully charged and memory may be unstable before the new Battery is inserted.

- 2 Open the compartment on the CPU Unit and carefully draw out the Battery. Remove the Battery connector. Connect the new Battery, place it into the compartment, and close the cover.

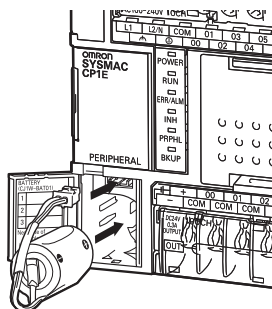



Precautions for Safe Use

- You must complete this procedure within 5 minutes after turning OFF the power to the CPU Unit to ensure memory backup.
If the Battery is removed for more than 5 minutes, data retained by the I/O memory (excluding the DM Area words saved to the backup memory) may be unstable.
 - Never short-circuit the Battery terminals; never charge the Battery; never disassemble the Battery; and never heat or incinerate the Battery. Doing any of these may cause the Battery to leak, heat, burn, or rupture, resulting in injury, fire, and possible loss of property.
Also, never use a Battery that has been dropped on the floor or otherwise subject to shock. It may leak.
UL standards require that batteries be replaced by experienced technicians. Always place an experienced technician in charge of Battery replacement.
 - Turn ON the power after replacing the Battery for a CPU Unit that has been unused for a long time.
Leaving the CPU Unit unused again without turning ON the power even once after the Battery is replaced may result in a shorter Battery life.
-



Additional Information

The Battery error will be cleared automatically the next time the CPU Unit is turned ON after replacing the Battery.

8

Using Expansion Units and Expansion I/O Units

This section describes the Analog Input Unit, Analog Output Unit, Temperature Sensor Units, CompoBus/S I/O Link Unit, and Expansion I/O Units.

8-1	Analog Input Units	8-2
8-1-1	Overview	8-2
8-1-2	Part Names and Functions	8-2
8-1-3	Specifications	8-3
8-1-4	Flow of Operation	8-7
8-2	Analog Output Units	8-15
8-2-1	Overview	8-15
8-2-2	Part Names and Functions	8-15
8-2-3	Specifications	8-16
8-2-4	Flow of Operation	8-20
8-3	Analog I/O Units	8-27
8-3-1	CP1W-MAD11 Analog I/O Units	8-27
8-3-2	CP1W-MAD42/CP1W-MAD44 Analog I/O Units	8-40
8-4	Temperature Sensor Units	8-56
8-4-1	CP1W-TS□1/TS□2 Temperature Sensor Units	8-56
8-4-2	CP1W-TS003 Temperature Sensor Units	8-71
8-4-3	TS004 Temperature Sensor Units	8-81
8-5	CompoBus/S I/O Link Units	8-92
8-5-1	Overview	8-92
8-5-2	Part Names and Functions	8-92
8-5-3	Specifications	8-94
8-5-4	Flow of Operation	8-94

8-1 Analog Input Units

8-1-1 Overview

Each CP1W-AD041/CP1W-AD042 Analog Input Unit provides four analog inputs.

- The analog input signal ranges are 0 to 5 V, 1 to 5 V, 0 to 10 V, -10 to +10 V, 0 to 20 mA, and 4 to 20 mA.
The resolution of CP1W-AD041 is 1/6,000.
The resolution of CP1W-AD042 is 1/12,000.
The open-circuit detection function is activated in the ranges of 1 to 5 V and 4 to 20 mA.
- The Analog Input Unit uses four input words and two output words.

8-1-2 Part Names and Functions

● CP1W-AD041/CP1W-AD042

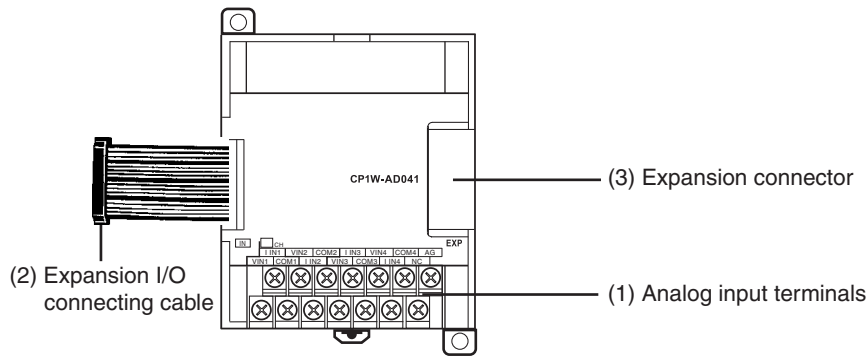

(1) Analog Input Terminals
Connected to analog output devices.

• Input Terminal Arrangement

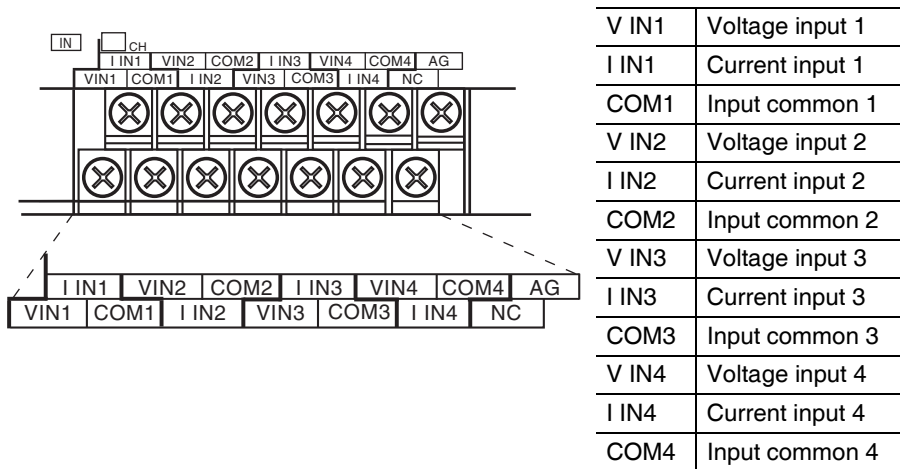

Note When using current inputs, voltage input terminals must be short-circuited with current input terminals.

(2) Expansion I/O Connecting Cable
Connected to the CPU Unit or Expansion Unit expansion connector. The cable is attached to the Analog Input Unit and cannot be removed.



Precautions for Safe Use

Do not touch the cables during operation. Static electricity may cause operating errors.

(3) Expansion Connector

Connected to the next Expansion Unit or Expansion I/O Unit to enable expansion.

8-1-3 Specifications

CP1W-AD041/AD042 Analog Input Units are connected to a CP1E CPU Unit.

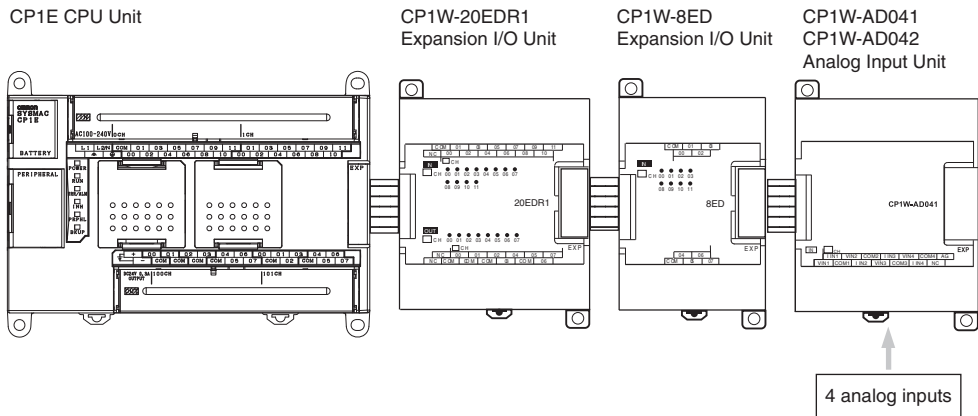

Model	CP1W-AD041		CP1W-AD042		
	Voltage input	Current input	Voltage input	Current input	
Number of analog inputs	4 inputs (4 words allocated)				
Input signal range	0 to 5 V, 1 to 5 V, 0 to 10 V, or -10 to 10 V	0 to 20 mA or 4 to 20 mA	0 to 5 VDC, 1 to 5 VDC, 0 to 10 VDC, or -10 to 10 VDC	0 to 20 mA or 4 to 20 mA	
Max. rated input	±15 V	±30 mA	±15 V	±30 mA	
External input impedance	1 MΩ min.	Approx. 250 Ω	1 MΩ min.	Approx. 250 Ω	
Resolution	1/6000 (full scale)		1/12000 (full scale)		
Overall accuracy	25°C	0.3% full scale	0.4% full scale	0.2% full scale	0.3% full scale
	0 to 55°C	0.6% full scale	0.8% full scale	0.5% full scale	0.7% full scale
A/D conversion data	16-bit binary (4-digit hexadecimal) Full scale for -10 to 10 V: F448 to 0BB8 hex Full scale for other ranges: 0000 to 1770 hex		16-bit binary (4-digit hexadecimal) Full scale for -10 to 10 V: E890 to 1770 hex Full scale for other ranges: 0000 to 2EE0 hex		
Averaging function	Supported (Set in output words n+1 and n+2.)				
Open-circuit detection function	Supported				
Conversion time	2 ms/point (8 ms/all points)		1 ms/point (4 ms/all points)		
Isolation method	Photocoupler isolation between analog input terminals and internal circuits. No isolation between analog I/O signals.				
Current consumption	5 VDC: 100 mA max.; 24 VDC: 90 mA max.		5 VDC: 100 mA max.; 24 VDC: 50 mA max.		

● **Analog Input Signal Ranges**

Analog input data is digitally converted according to the input signal range as shown below.



Additional Information

When the input exceeds the specified range, the A/D conversion data will be fixed at either the lower limit or upper limit.

-10 to 10 V Inputs

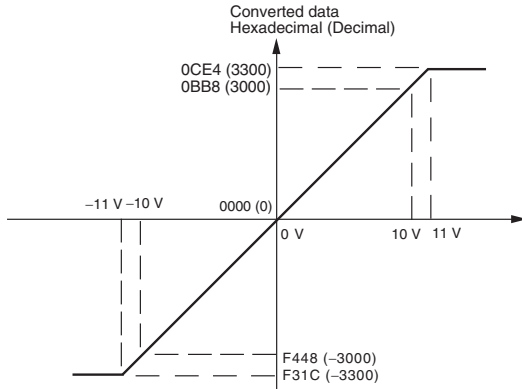

When the resolution is 1/6,000, the -10 to 10 V range correspond to hexadecimal values F448 to 0BB8 (-3,000 to 3,000). The range of data that can be converted is F31C to 0CE4 hex (-3,300 to 3,300). A negative voltage is expressed as a two's complement.

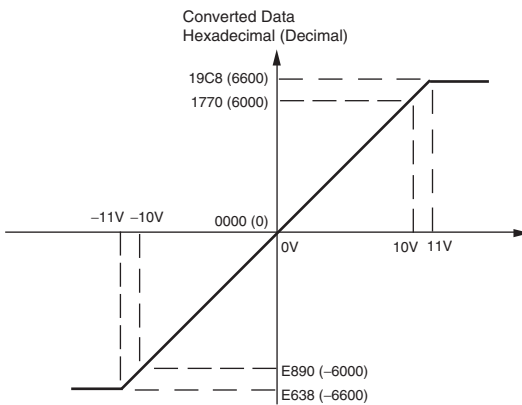

When the resolution is 1/12,000, the -10 to 10 V range correspond to hexadecimal values E890 to 1770 (-6,000 to 6,000). The entire data range is E638 to 19C8 hex (-6,600 to 6,600). A negative voltage is expressed as a two's complement.

0 to 10 V Inputs

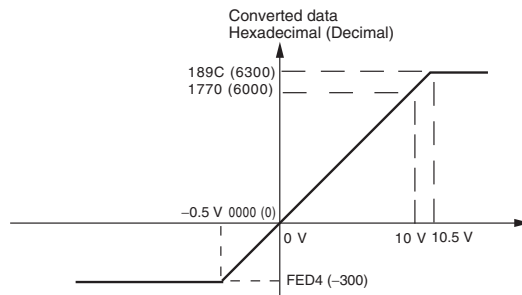

When the resolution is 1/6,000, the 0 to 10 V range correspond to hexadecimal values 0000 to 1770 (0 to 6,000). The range of data that can be converted is FED4 to 189C hex (-300 to 6,300). A negative voltage is expressed as a two's complement.

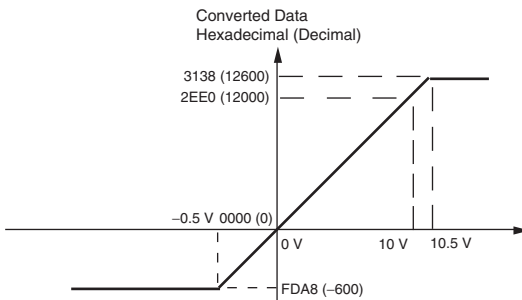

When the resolution is 1/12,000, the 0 to 10 V range correspond to hexadecimal values 0000 to 2EE0 (0 to 12,000). The entire data range is FDA8 to 3138 hex (-600 to 12,600). A negative voltage is expressed as a two's complement.

0 to 5 V Inputs

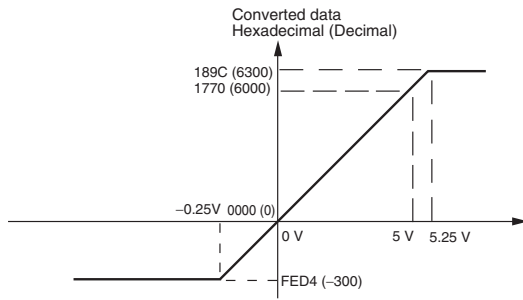

When the resolution is 1/6,000, the 0 to 5 V range correspond to hexadecimal values 0000 to 1770 (0 to 6,000). The range of data that can be converted is FED4 to 189C hex (-300 to 6,300). A negative voltage is expressed as a two's complement.

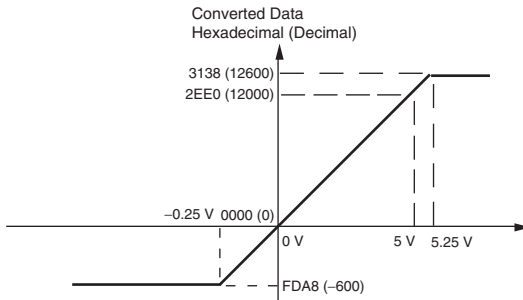

When the resolution is 1/12,000, the 0 to 5 V range correspond to hexadecimal values 0000 to 2EE0 (0 to 12,000). The entire data range is FDA8 to 3138 hex (-600 to 12,600). A negative voltage is expressed as a two's complement.

1 to 5 V Inputs

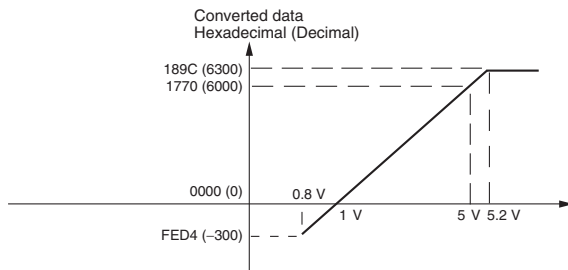

When the resolution is 1/6,000, the 1 to 5 V range correspond to hexadecimal values 0000 to 1770 (0 to 6,000). The range of data that can be converted is FED4 to 189C hex (-300 to 6,300). Voltage in the range of 0.8 to 1 V is expressed as a two's complement.

If an input is below the range (i.e., less than 0.8 V), the open-circuit detection function is activated and the data becomes 8,000.

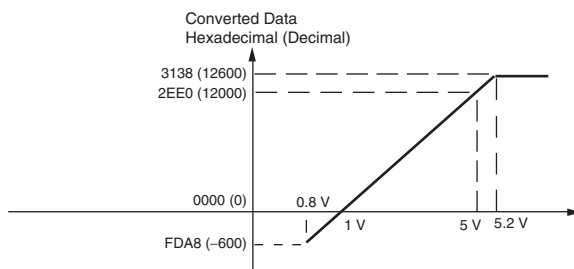

When the resolution is 1/12,000, the 1 to 5 V range correspond to hexadecimal values 0000 to 2EE0 (0 to 12,000). The entire data range is FDA8 to 3138 hex (-600 to 12,600). Voltage in the range of 0.8 to 1 V is expressed as two's complement.

If an input is below the range (i.e., less than 0.8 V), the open-circuit detection function is activated and the data becomes 8,000.

0 to 20 mA Inputs

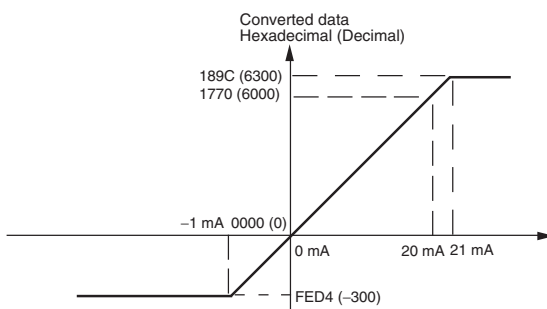

When the resolution is 1/6,000, the 0 to 20 mA range correspond to hexadecimal values 0000 to 1770 (0 to 6,000). The range of data that can be converted is FED4 to 189C hex (-300 to 6,300). A negative current is expressed as a two's complement.

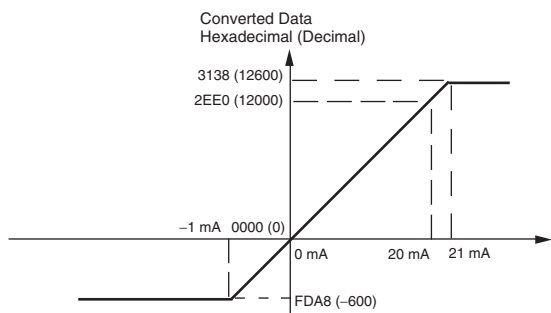

4 to 20 mA Inputs

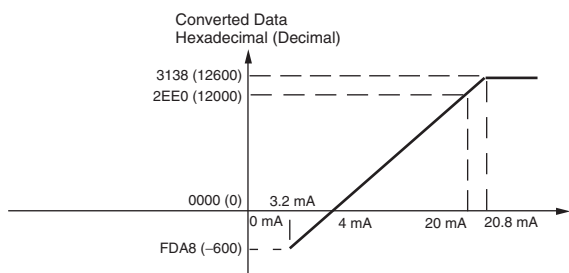
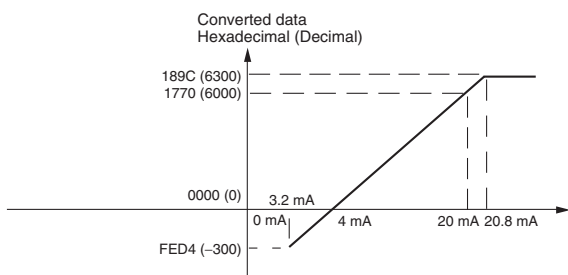

When the resolution is 1/12,000, the 0 to 20 mA range correspond to hexadecimal values 0000 to 2EE0 (0 to 12,000). The entire data range is FDA8 to 3138 hex (-600 to 12,600). A negative voltage is expressed as a two's complement.

When the resolution is 1/6,000, the 4 to 20 mA range correspond to hexadecimal values 0000 to 1770 (0 to 6,000). The range of data that can be converted is FED4 to 189C hex (-300 to 6,300). Current in the range of 3.2 to 4 mA is expressed as a two's complement.

If an input is below the range (i.e., less than 3.2 mA), the open-circuit detection function is activated and the data becomes 8,000.

When the resolution is 1/12,000, the 4 to 20mA range correspond to hexadecimal values 0000 to 2EE0 (0 to 12,000). The entire data range is FDA8 to 3138 hex (-600 to 12,600). Current in the range of 3.2 to 4 mA is expressed as two's complement.

If an input is below the range (i.e., less than 3.2 mA), the open-circuit detection function is activated and the data becomes 8,000.

● Averaging Function

For analog inputs, the averaging function operates when the averaging bit is set to 1. The averaging function outputs the average (a moving average) of the last eight input values as the converted value.

Use this function to smooth inputs that vary at a short interval.

● Open-circuit Detection

The open-circuit detection function is activated when the input range is set to 1 to 5 V and the voltage drops below 0.8 V, or when the input range is set to 4 to 20 mA and the current drops below 3.2 mA.

When the open-circuit detection function is activated, the converted data will be set to 8,000.

The time for enabling or clearing the open-circuit detection function is the same as the time for converting the data. If the input returns to the convertible range, the open-circuit detection is cleared automatically and the output returns to the normal range.

8-1-4 Flow of Operation

- 1** Connect and wire Units.
 - Connect Analog Input Units.
 - Wire to analog output devices.
- ↓
- 2** Create a ladder program.
 - Write set data to output words (n+1, n+2).
 - Set use of inputs.
 - Select input signals using range codes.
 - Set use of averaging.
 - Read A/D converted values from input words (m+1 to m+4).
 - For current inputs, confirm that there is no open circuit.

● Writing Set Data and Reading A/D Converted Values

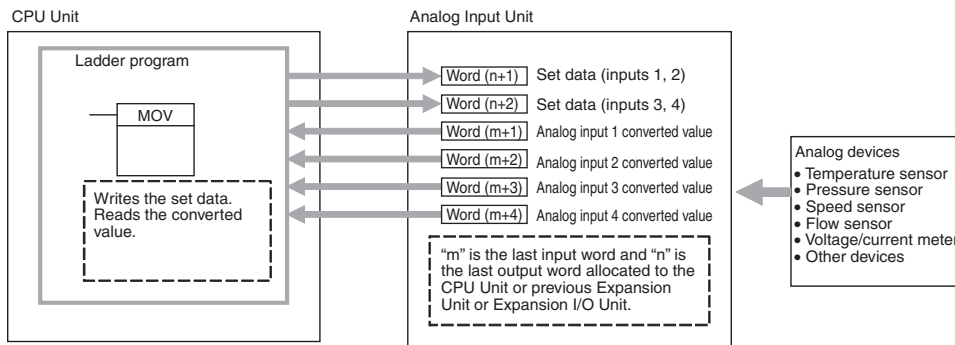

- 1** Connect the Analog Input Unit to the CPU Unit.

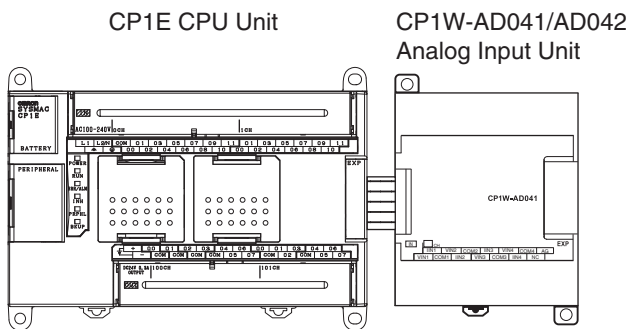

2 Wire to analog output devices.

(1) Wiring internal circuits of the CPU Unit

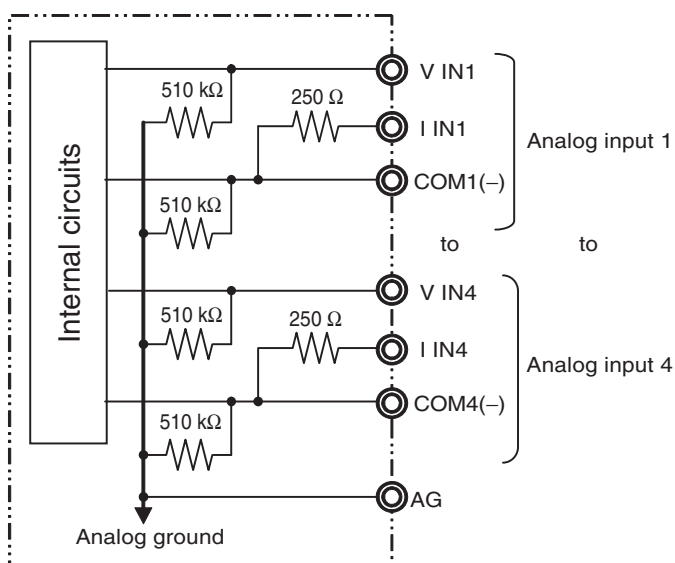

(2) Wiring analog output devices to the Analog Input Unit

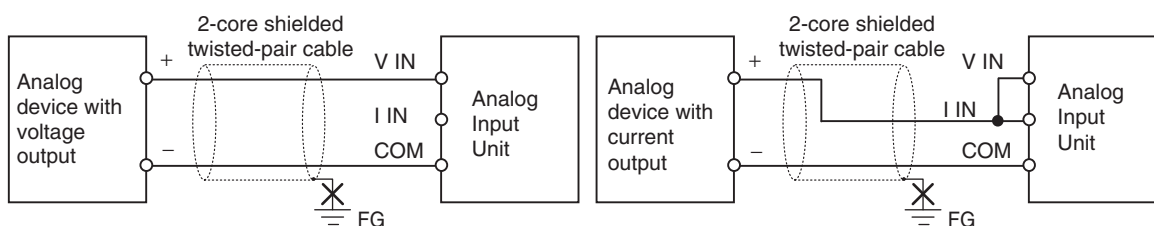

Precautions for Correct Use

- Do not connect the shield when using shielded twisted-pair cables.
- When an input is not being used, short V IN and I IN to COM terminals.
- Separate wiring from power lines (AC power supply lines, high-voltage lines, etc.)
- When there is noise in the power supply line, install a noise filter on the input section and the power supply.



Additional Information

Refer to the following information on open circuits when using voltage inputs.

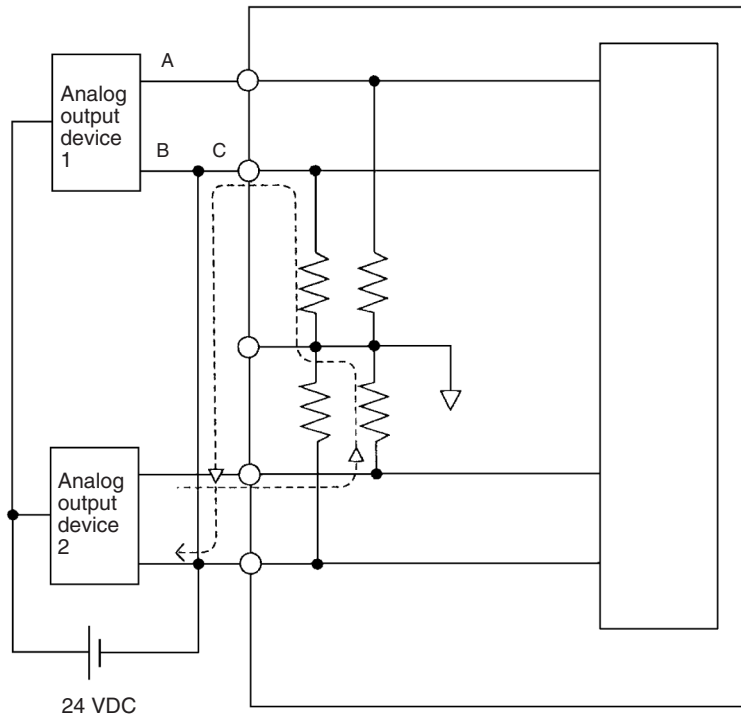

For example, if connected device 2 is outputting 5 V and the same power supply is being used for both devices as shown above, approximately 1/3, or 1.6 V, will be applied to the input for input device 1.

If a wiring disconnection occurs when voltage input is being used, the situation described below will result. Either separate the power supplies for the connected devices, or use an isolator for each input.

- If the same power supply is being used by the connected devices and a disconnection occurs at points A or B in the above diagram, an unwanted circuit path will occur as shown along the dotted line in the diagram. If that occurs, a voltage of approximately 1/3 to 1/2 of the output voltage of the other connected device will be generated.
- If that voltage is generated while the setting is for 1 to 5 V, open-circuit detection may not be possible.
- If a disconnection occurs at point C in the diagram, the negative (-) side will be used for both devices and open-circuit detection will not be possible.

This problem will not occur for current inputs even if the same power supply is used.

3 Create the ladder program.

(1) Allocating I/O Words

Four input words and two output words are allocated from the next words following the last I/O words allocated to the CPU Unit or an existing Expansion Unit or Expansion I/O Unit.

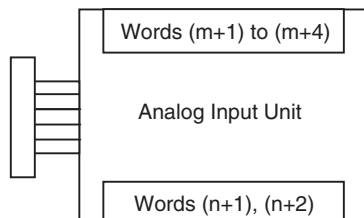

(2) Writing Set Data

Write the settings for input use, averaging use, and range codes for words n+1 and n+2. When the set data is transferred from the CPU Unit to the Analog Input Unit, the A/D conversion will be started.

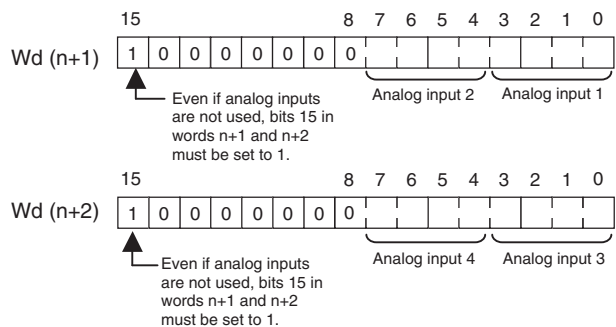

• Set Data

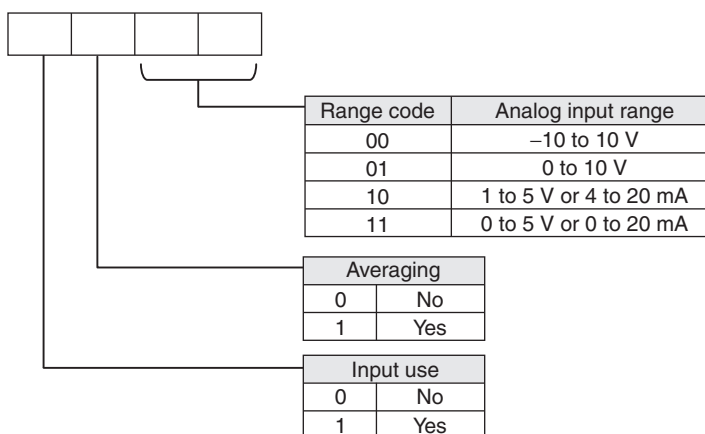

- The Analog Input Unit will not start converting analog input values until the set data has been written. The conversion data will be 0000 until the range code is written.
- Once the settings have been made, it is not possible to be changed while power is being supplied to the CPU Unit. To change the range code or other settings, turn the CPU Unit OFF then ON again.

(3) Averaging

Set whether averaging is to be used for set data. When the averaging bit is set to 1, the average (moving average) for the past eight inputs is output as conversion data.

(4) Reading Analog Input Conversion Values

The ladder program can be used to read the memory area words where the converted values are stored.

With word *m* as the last input word allocated to the CPU Unit or an already-connected Expansion Unit, the A/D conversion data will be output to the following words *m*+1 to *m*+4.

(5) Startup Operation

After the power is turned ON, it will require two cycle times plus approximately 50 ms before the first conversion data is stored in the input words. Therefore, create a program as shown below, so that the ladder can start to operate with valid conversion data in input words.

The analog input data will be 0000 until the first conversion data is stored in the input words.

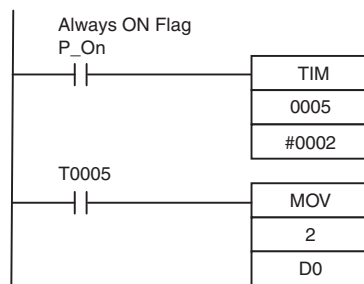

TIM0005 is started when the power is turned ON. After 0.2 s (200 ms) elapses, the TIM0005 contact turns ON and the analog input 1 conversion data stored in CIO 2 is transferred to D0.

(6) Handling Unit Errors

- When an error occurs in an Analog Input Unit, the analog input conversion data becomes 0000.
- Expansion Unit errors are output to bits 0 to 5 of word A436 for Units 1 to 3. The bits are allocated from A436.00 in order starting with the Unit nearest the CPU Unit. CP1W-AD041 is allocated two bits each. Use these flags in the program when it is necessary to detect errors.

(7) Program Example

Analog input	Input range	Range code	Averaging	Set data	Destination word
Input 1	0 to 10 V	01	Yes	1101 (D hex)	n+1
Input 2	4 to 20 mA	10	Yes	1110 (E hex)	n+1
Input 3	-10 to +10 V	00	No	1000 (8 hex)	n+2
Input 4	Not used.	-(00)	-	0000 (0 hex)	n+2

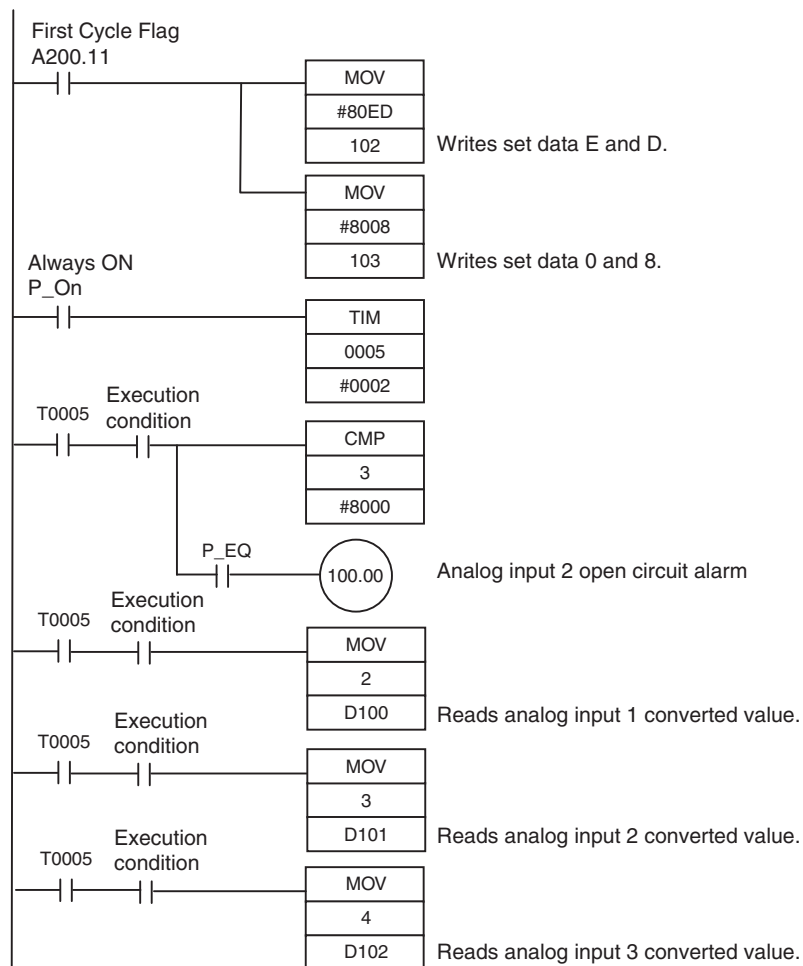

• Example: Scaling analog input values

When a 0 to 10V voltage is input to the analog input word (CIO 3) of CP1W-AD042 as 0 to 12,000, convert the value into a value between 0 and 24,000 and output the result to D200.

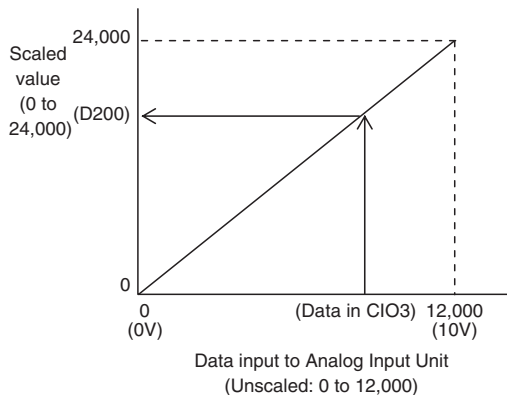

Data Memory Settings

Setting	Address	Data
Control word	D100	#0800
Unscaled minimum value (0)	D101	&0
Scaled minimum value (0)	D102	&0
Unscaled maximum value (12,000)	D103	&12,000
Scaled maximum value (24,000)	D104	&24,000

Ladder Program

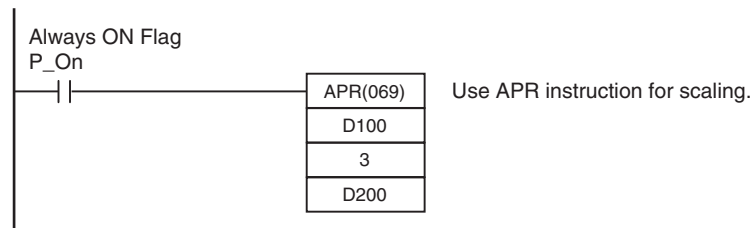

Descriptions of APR Instruction

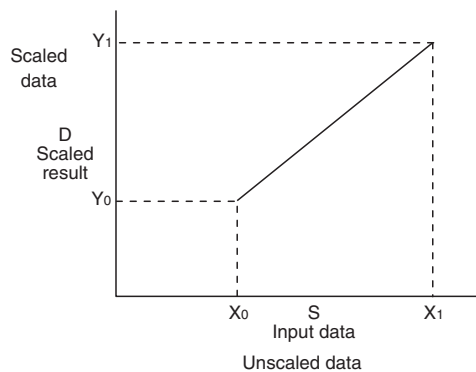
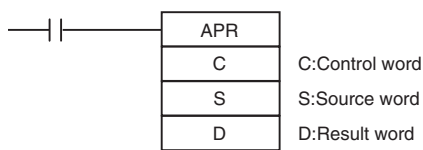

C: Control word

Set for "Signed Integer Data (Binary)".

Control word setting

#0800: Binary numeral (0000 1000 0000 0000)

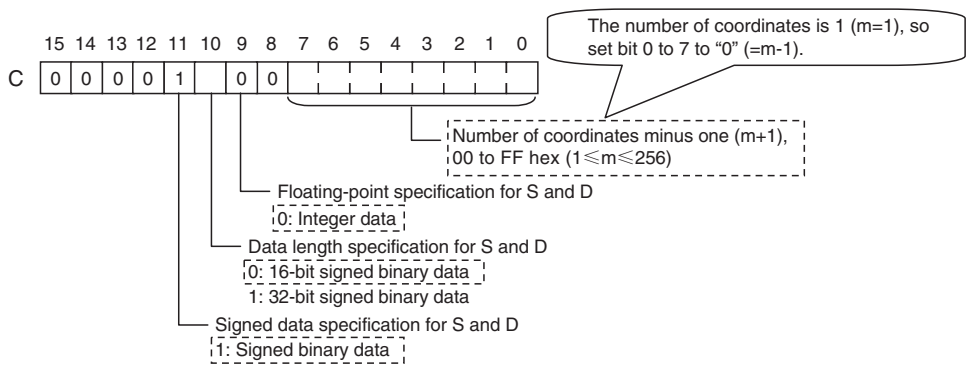

Setting	Address	Data
Control word	C	#0800
Unscaled minimum value (X_0)	C+1	X_0
Scaled minimum value (Y_0)	C+2	Y_0
Unscaled maximum value ($X_m = X_1$)	C+3	X_1
Scaled maximum value ($Y_m = Y_1$)	C+4	Y_1

S: Source data

Specify the word address of the input data before scaling.

R: Result word

Specify the word address where the data will be output after scaling.

8-2 Analog Output Units

8-2-1 Overview

Each CP1W-DA021 Analog Output Unit provides two analog outputs.

Each CP1W-DA041/CP1W-DA042 Analog Output Unit provides four analog outputs.

- The analog output signal ranges are 1 to 5 V, 0 to 10 V, -10 to +10 V, 0 to 20 mA, and 4 to 20 mA. The resolution of CP1W-DA021/DA041 is 1/6,000. The resolution of CP1W-DA042 is 1/12,000.
- CP1W-DA021 uses two output words and CP1W-DA041/DA042 uses four output words.

8-2-2 Part Names and Functions

● CP1W-DA021/CP1W-DA041/CP1W-DA042

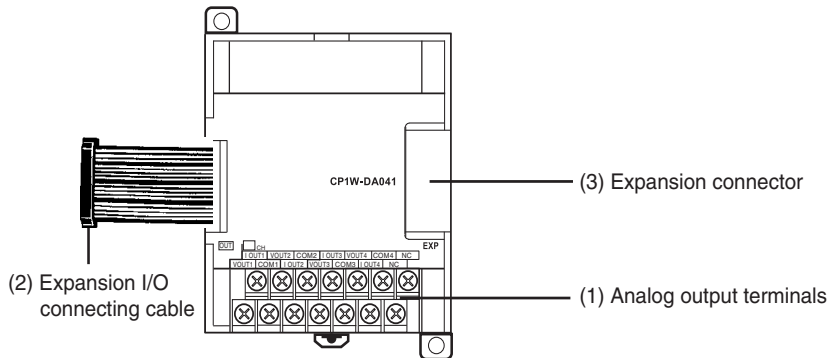

(1) Analog Output Terminals
Connected to analog input devices.

- I/O Terminal Arrangement for CP1W-DA021

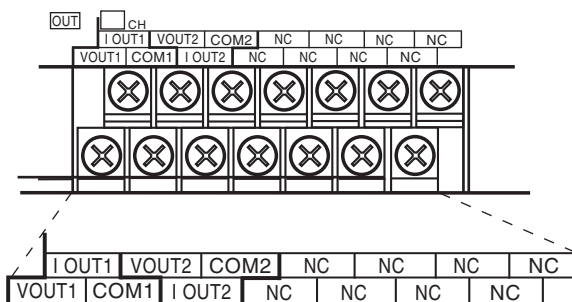

V OUT1	Voltage output 1
I OUT1	Current output 1
COM1	Output common 1
V OUT2	Voltage output 2
I OUT2	Current output 2
COM2	Output common 2

- I/O Terminal Arrangement for CP1W-DA041/DA042

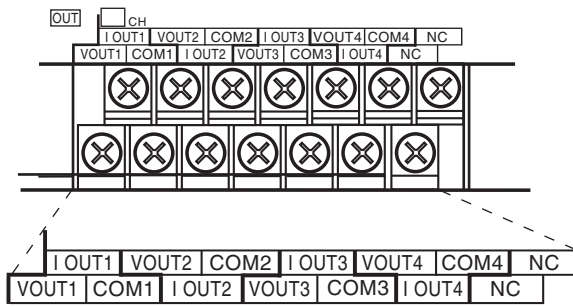

V OUT1	Voltage output 1
I OUT1	Current output 1
COM1	Output common 1
V OUT2	Voltage output 2
I OUT2	Current output 2
COM2	Output common 2
V OUT3	Voltage output 3
I OUT3	Current output 3
COM3	Output common 3
V OUT4	Voltage output 4
I OUT4	Current output 4
COM4	Output common 4

(2)Expansion I/O Connecting Cable

Connected to the expansion connector on the CPU Unit or previous Expansion Unit. The cable is provided with the Unit and cannot be removed.



Precautions for Safe Use

Do not touch the cables during operation. Static electricity may cause operating errors.

(3)Expansion Connector

Connected to the next Expansion Unit or Expansion I/O Unit.

8-2-3 Specifications

CP1W-DA021/DA041/DA042 Analog Output Units are connected to a CP1E CPU Unit.

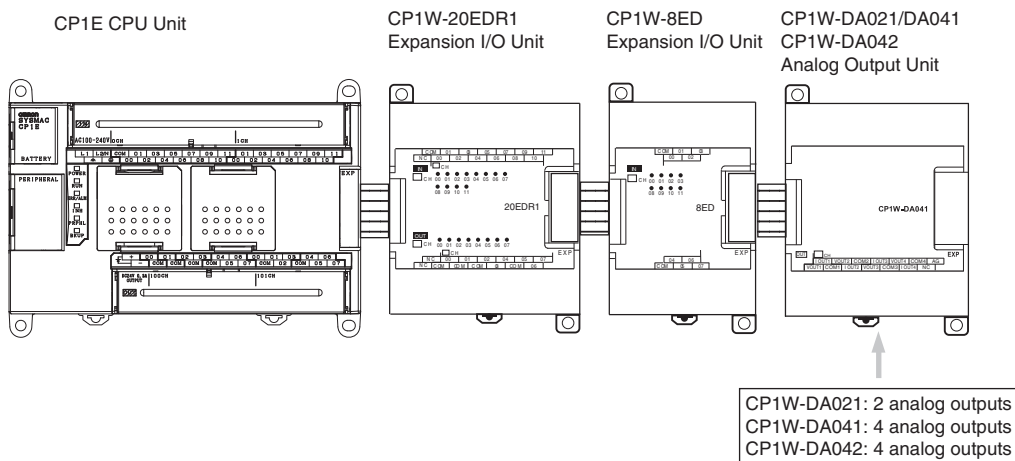

Model		CP1W-DA021/CP1W-DA041		CP1W-DA042		
Item		Voltage output	Current output	Voltage output	Current output	
Analog output section	Number of analog outputs	CP1W-DA021: 2 outputs (2 words allocated) CP1W-DA041: 4 outputs (4 words allocated)		4 outputs (4 words allocated)		
	Output signal range	1 to 5 V, 0 to 10 V, or -10 to 10 V	0 to 20 mA or 4 to 20 mA	1 to 5 V, 0 to 10 V, or -10 to 10 V	0 to 20 mA or 4 to 20 mA	
	External output allowable load resistance	2 k Ω min.	350 Ω max.	2 k Ω min.	350 Ω max.	
	External output impedance	0.5 Ω max.	–	0.5 Ω max.	–	
	Resolution	1/6000 (full scale)		1/12000 (full scale)		
	Overall accuracy	25°C	0.4% full scale		0.3% full scale	
		0 to 55°C	0.8% full scale		0.7% full scale	
D/A conversion data	16-bit binary (4-digit hexadecimal) Full scale for -10 to 10 V: F448 to 0BB8 hex Full scale for other ranges: 0000 to 1770 hex		16-bit binary (4-digit hexadecimal) Full scale for -10 to 10 V: E890 to 1770 hex Full scale for other ranges: 0000 to 2EE0 hex			
Conversion time	CP1W-DA021: 2 ms/point (4 ms/all points) CP1W-DA041: 2 ms/point (8 ms/all points)		1 ms/point (4 ms/all points)			
Isolation method	Photocoupler isolation between analog I/O terminals and internal circuits. No isolation between analog I/O signals.					
Current consumption	CP1W-DA021: 5 VDC 40 mA max.; 24 VDC 95 mA max. CP1W-DA041: 5 VDC 80 mA max.; 24 VDC 124 mA max.		5 VDC: 70 mA max.; 24 VDC: 160 mA max.			

● Analog Output Signal Ranges

The output data is converted to analog according to the output signal range, as shown below.



Additional Information

When the output exceeds the specified range, the output signal will be fixed at either the lower limit or upper limit.

-10 to 10 V

When the resolution is 1/6,000, the hexadecimal values F448 to 0BB8 (-3000 to 3000) correspond to an analog voltage range of -10 to 10 V.

The entire output range is -11 to 11 V.

Specify the DA conversion data as the two's complement if it is a negative value.

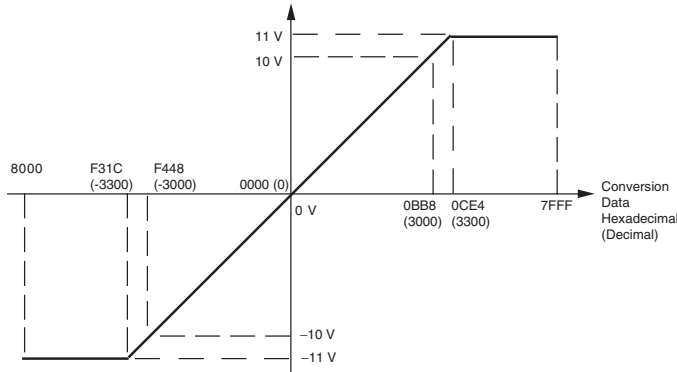

When the resolution is 1/12,000, the hexadecimal values E890 to 1770 (-6000 to 6000) correspond to an analog voltage range of -10 to 10 V.

The entire output range is -11 to 11 V.

Specify the DA conversion data as the two's complement if it is a negative value.

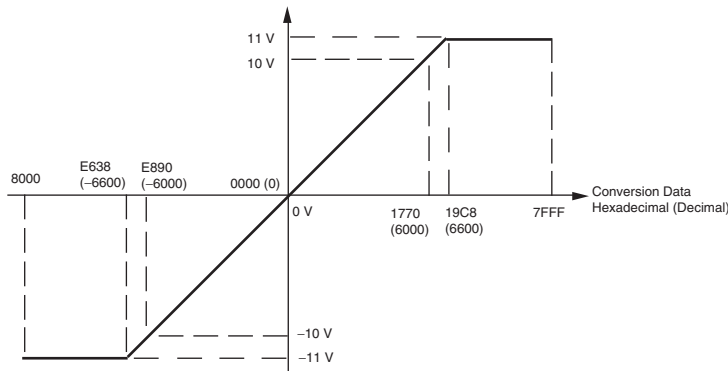

0 to 10 V

When the resolution is 1/6,000, the hexadecimal values 0000 to 1770 (0 to 6000) correspond to an analog voltage range of 0 to 10 V.

The entire output range is -0.5 to 10.5 V.

Specify the DA conversion data as the two's complement if it is a negative value.

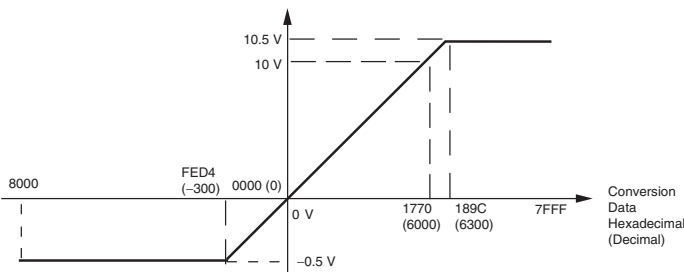

When the resolution is 1/12,000, the hexadecimal values 0000 to 2EE0 (0 to 12000) correspond to an analog voltage range of 0 to 10 V.

The entire output range is -0.5 to 10.5 V.

Specify the DA conversion data as the two's complement if it is a negative value.

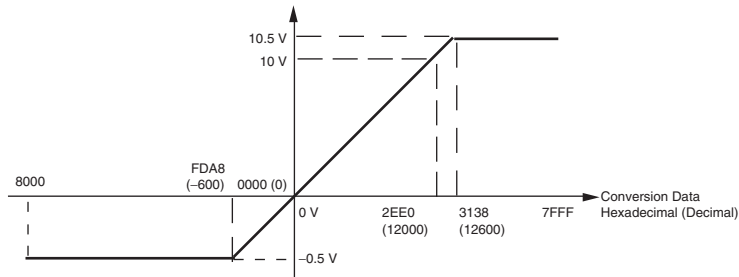

1 to 5 V

When the resolution is 1/6,000, the hexadecimal values 0000 to 1770 (0 to 6000) correspond to an analog voltage range of 1 to 5 V.

The entire output range is 0.8 to 5.2 V.

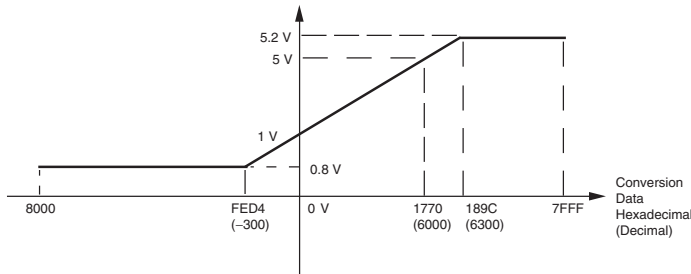

When the resolution is 1/12,000, the hexadecimal values 0000 to 2EE0 (0 to 12000) correspond to an analog voltage range of 1 to 5 V.

The entire output range is 0.8 to 5.2 V.

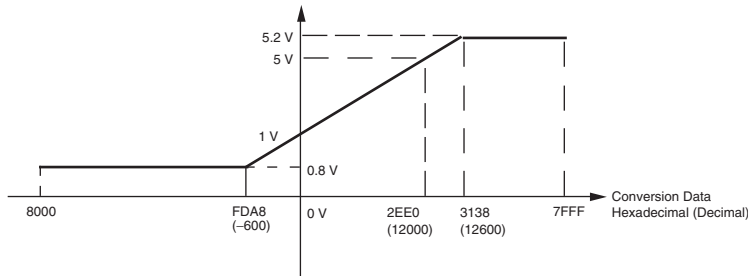

0 to 20 mA

When the resolution is 1/6,000, the hexadecimal values 0000 to 1770 (0 to 6000) correspond to an analog current range of 0 to 20 mA.

The entire output range is 0 to 21 mA.

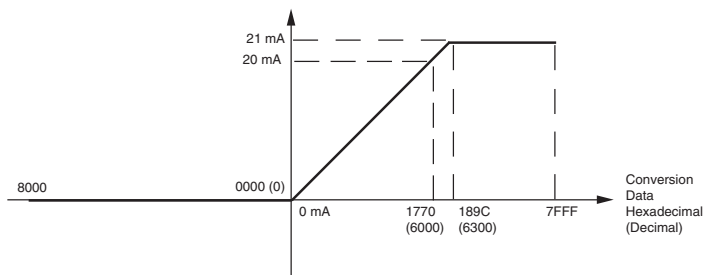

When the resolution is 1/12,000, the hexadecimal values 0000 to 2EE0 (0 to 12000) correspond to an analog voltage range of 0 to 20 mA.
The entire output range is 0 to 21 mA.

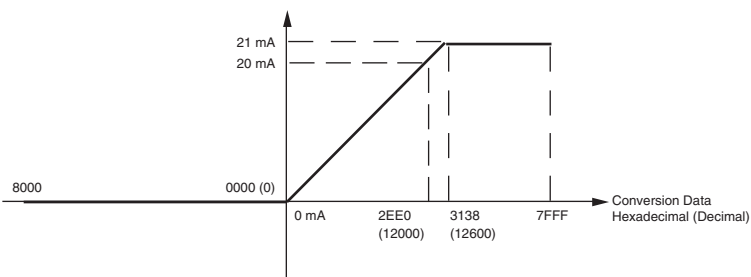

4 to 20 mA

When the resolution is 1/6,000, the hexadecimal values 0000 to 1770 (0 to 6000) correspond to an analog current range of 4 to 20 mA.
The entire output range is 3.2 to 20.8 mA.

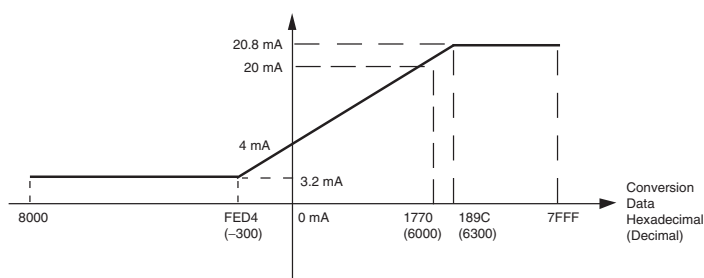

When the resolution is 1/12,000, the hexadecimal values 0000 to 2EE0 (0 to 12000) correspond to an analog voltage range of 4 to 20 mA.
The entire output range is 3.2 to 20.8 mA.

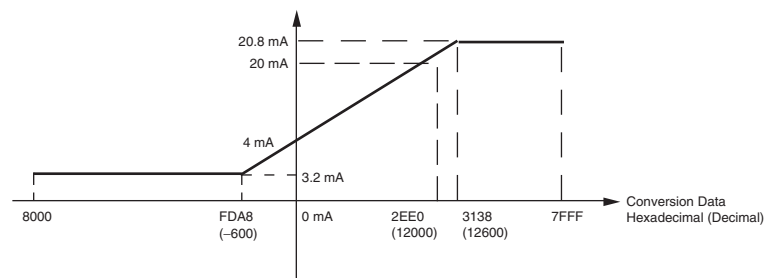

8-2-4 Flow of Operation

1

Connect and wire Units.

- Connect Analog Output Units.
- Wire to analog input devices.



2

Create a ladder program.

- Write range code to output words
CP1W-DA021: Word n+1
CP1W-DA041/DA042: Words n+1, n+2
 - Set use of outputs.
 - Select output signals using range codes.
- Write D/A conversion values to output words
CP1W-DA021: Words n+1, n+2
CP1W-DA041/DA042: Words n+1 to n+4

● Writing Set Data and Writing D/A Conversion Data

CP1W-DA021

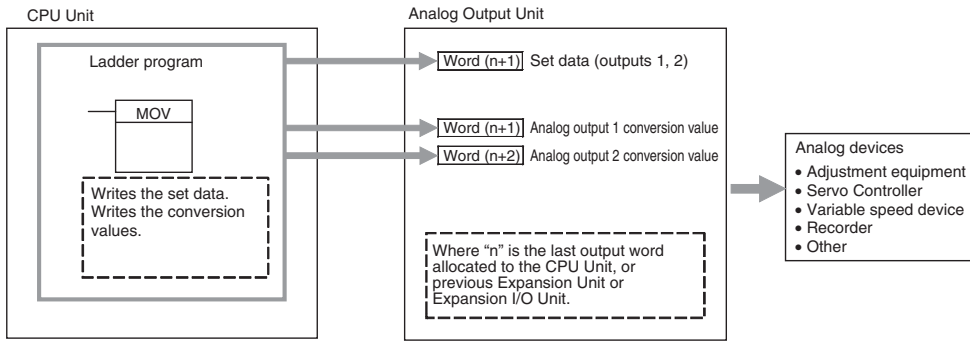

CP1W-DA041/CP1W-DA042

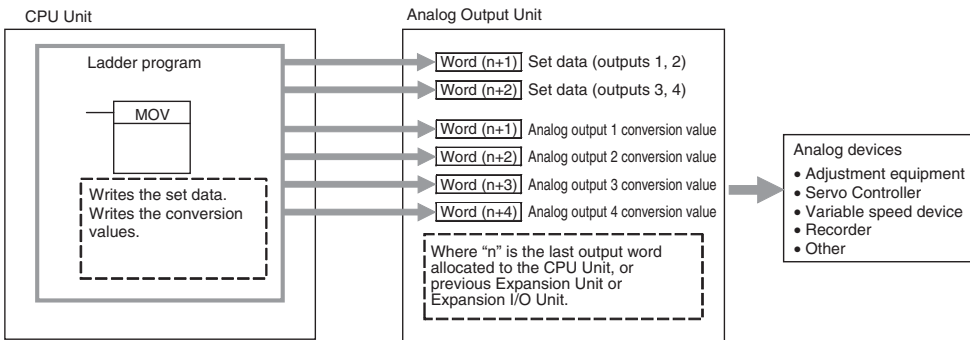

1 Connect the Analog Output Unit to the CPU Unit.

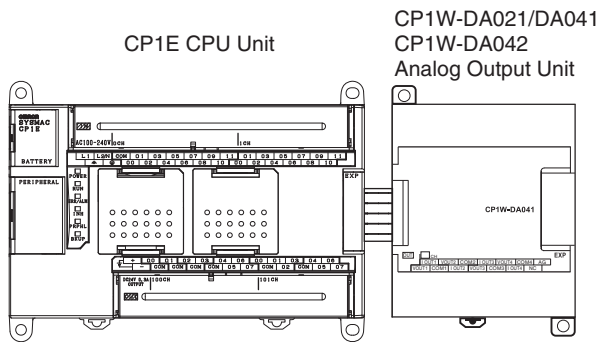

2 Wire to analog input devices.

(1) Wiring internal circuits of the CPU Unit

The following diagram shows the internal circuit using CP1W-DA041/DA042 as an example, which wires analog outputs 1 to 4. In the case of CP1W-DA021, analog outputs 1 to 2 can be used.

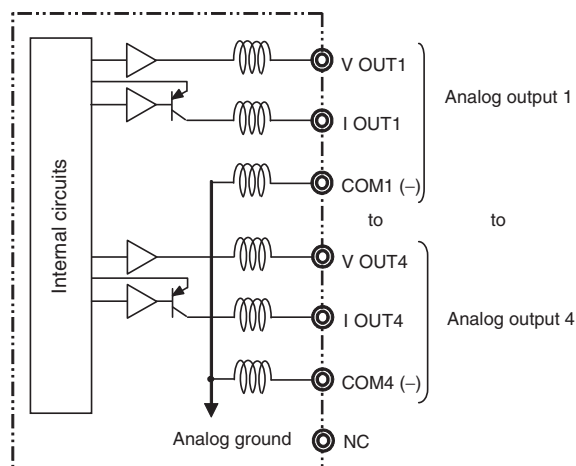

(2) Wiring analog input devices to the Analog Output Unit

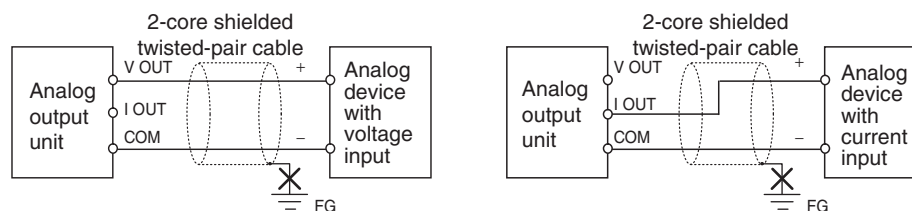

Precautions for Correct Use

- Do not connect the shield when using shielded twisted-pair cables.
- Separate wiring from power lines (AC power supply lines, high-voltage lines, etc.)
- When there is noise in the power supply line, install a noise filter on the input section and the power supply.



Additional Information

When external power is supplied (when setting the range code), or when there is a power interruption, a pulse-form analog output may be generated.

If this causes problems with operation, take countermeasures such as those suggested below.

(1) Countermeasure 1

- Turn ON the power supply for the CP1E CPU Unit first, confirm correct operation, and then turn ON the power supply for the load.
- Turn OFF the power supply for the load before turning OFF the power supply for the CP1E CPU Unit.

(2) Countermeasure 2

- Control the machine not only by analog output but also by other signals (additional start/stop control signal for machine).

3 Create the ladder program.

(1) Allocating Output Words

Four output words (n+1 to n+4) are allocated to the Analog Output Unit starting from the next word following the last word allocated to the CPU Unit or previous Expansion Unit or Expansion I/O Unit. For CP1W-DA021, two output words (n+1, n+2) are allocated.

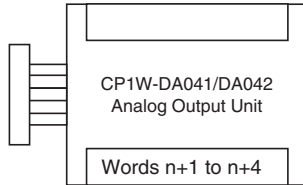

(2) Writing Set Data

Write the output use and the range code to words n+1 and n+2. For CP1W-DA021, only word n+1 can be used. The D/A conversion will start when the set data is transferred from the CPU Unit to the Analog Output Unit.

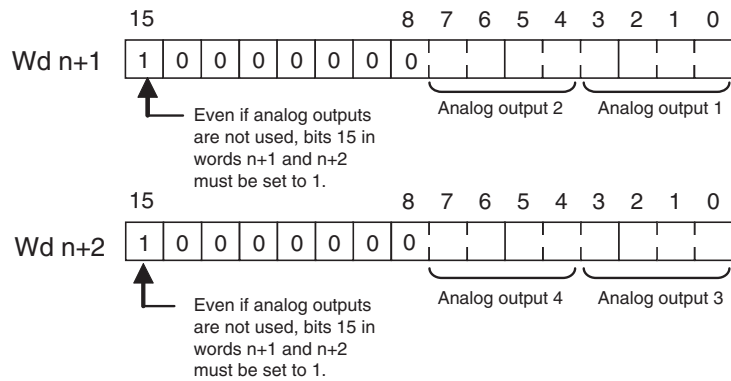

• Set Data

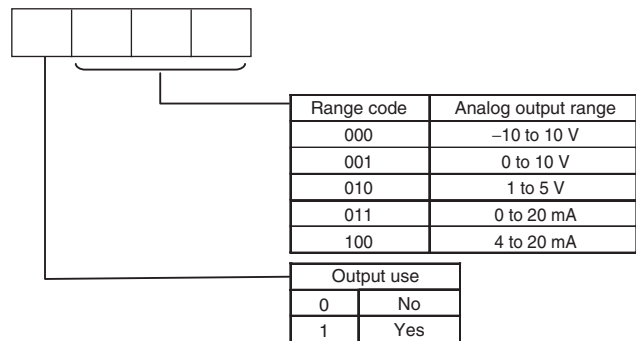

- The Analog Output Unit will not start converting analog output values until the set data has been written.
- Before the range code is written, 0 V or 0 mA will be output for the 0 to 10V, -10 to 10V, or 0 to 20 mA ranges, and 1 V or 4 mA will be output for the 1 to 5V and 4 to 20 mA ranges.
- Once the range code has been set, it is not possible to be changed while power is being supplied to the CPU Unit. To change the range code, turn the CPU Unit OFF then ON again.

(3) Writing Analog Output Conversion Values

The ladder program can be used to write conversion data to the output words.

When “n” is the last output word allocated to the CPU Unit, or previous Expansion Unit or Expansion I/O Unit, the output words will be n+1 to n+2 for CP1W-DA021 and n+1 to n+4 for CP1W-DA041/DA042.

(4) Startup Operation

After power is turned ON, it will require two cycle times plus approximately 50 ms before the first conversion data is output.

The following table shows the output status after the initial processing is completed.

Output type	Voltage output		Current output	
Output range	0 to 10 V, -10 to +10 V	1 to 5 V	0 to 20 mA	4 to 20 mA
Before range code is written	0V		0mA	
After range code is written	0V	1V	0mA	4mA

Therefore, create a program as shown below, so that when operation begins simultaneously with startup it will wait for valid set data.

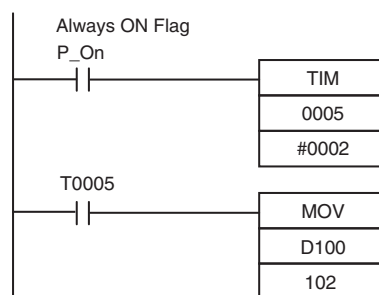

TIM0005 is started when the power is turned ON. After 0.2 s (200 ms) elapses, the TIM0005 contact turns ON and the data stored in D100 will be moved to CIO 102 as the conversion data for analog output 1.

(5) Handling Unit Errors

- When an error occurs at the Analog Output Unit, the analog output will be 0 V or 0 mA. If a CPU error or an I/O bus error (fatal errors) occurs at the CPU Unit and the analog output is set to 1 to 5 V or 4 to 20 mA, 0 V or 0 mA will be output. For any other fatal errors at the CPU Unit, 1 V or 4 mA will be output.
- Expansion Unit and Expansion I/O Unit errors are output to bits 0 to 5 of word A436 for units 1 to 3. The bits are allocated from A436.00 in order starting from the Unit nearest the CPU Unit. CP1W-DA041/DA042 is allocated two bits each and CP1W-DA021 is allocated one bit each. Use these flags in the program when it is necessary to detect errors.

(6) Program Example (CP1W-DA041/DA042)

Analog output	Output range	Range code	Set data	Destination word
Output 1	0 to 10 V	001	1001 (9 hex)	n+1
Output 2	4 to 20 mA	100	1100 (C hex)	n+1
Output 3	-10 to 10 V	000	1000 (8 hex)	n+2
Output 4	Not used.	-(000)	0000 (0 hex)	n+2

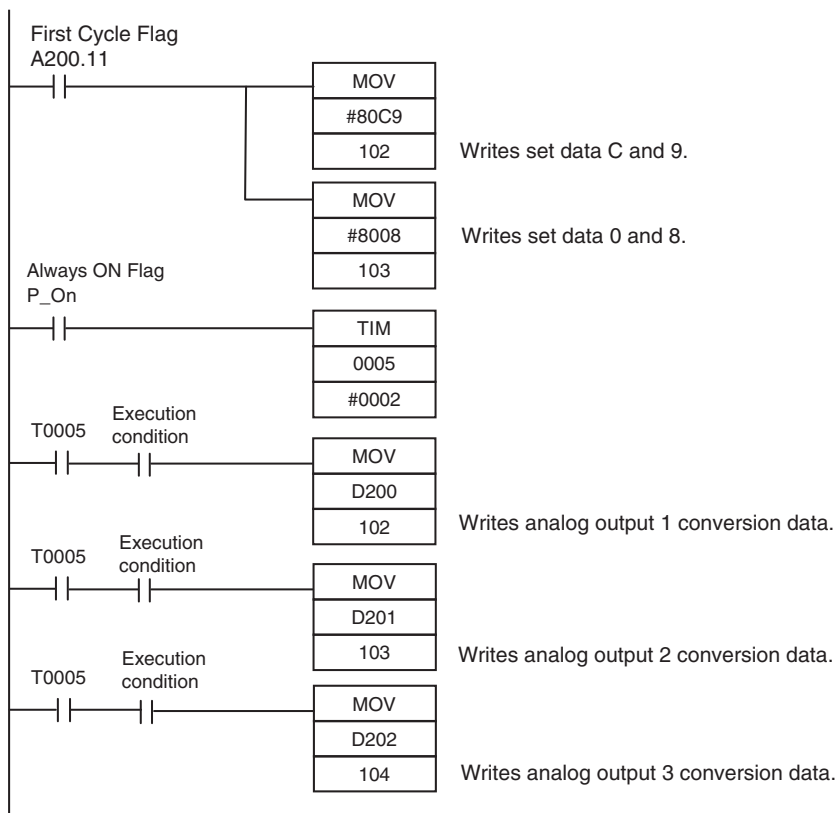

- Example: Scaling analog output values

Convert a value between 200 and 500 in D300 into 2 to 5 V to output the voltage from the analog output word (CIO 102) of CP1W-DA042.

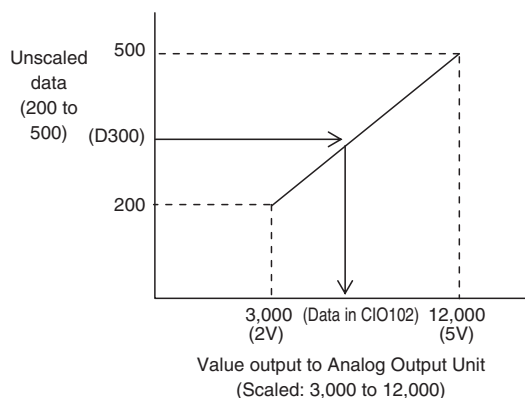

Data memory settings

Setting	Address	Data
Control word	D110	#0800
Unscaled minimum value (200)	D111	&200
Scaled minimum value (3,000)	D112	&3,000
Unscaled maximum value (500)	D113	&500
Scaled maximum value (12,000)	D114	&12,000

Ladder program

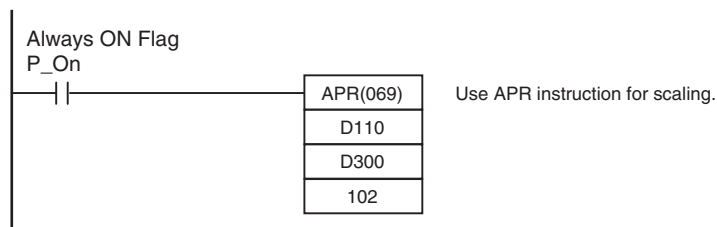

Refer to 8-1 Example: Scaling analog input values for the descriptions of APR instruction.

8-3 Analog I/O Units

8-3-1 CP1W-MAD11 Analog I/O Units

Overview

Each CP1W-MAD11 Analog I/O Unit provides 2 analog inputs and 1 analog output.

- The analog input range can be set to 0 to 5 V, 1 to 5 V, 0 to 10 V, -10 to 10 V, 0 to 20 mA, or 4 to 20 mA. The inputs have a resolution of 1/6000. An open-circuit detection function is activated in the ranges of 1 to 5 V and 4 to 20 mA.
- The analog output range can be set to 1 to 5 V, 0 to 10 V, -10 to 10 V, 0 to 20 mA, or 4 to 20 mA. The outputs have a resolution of 1/6000.

Part Names and Functions

● CP1W-MAD11

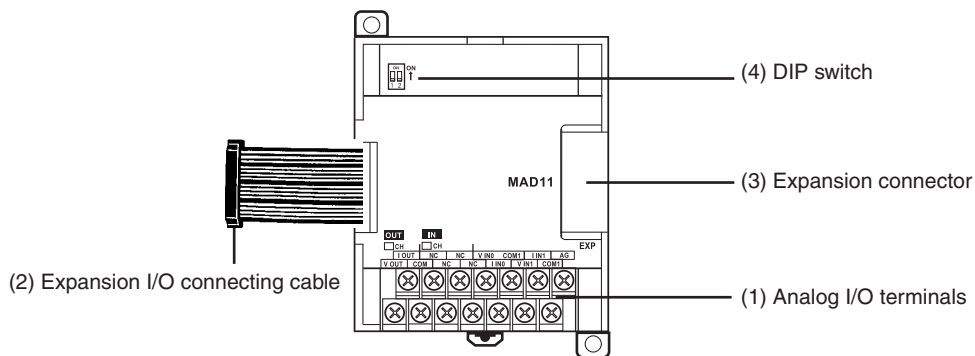

- (1) Analog I/O Terminals
Connected to analog I/O devices.

• I/O Terminal Arrangements

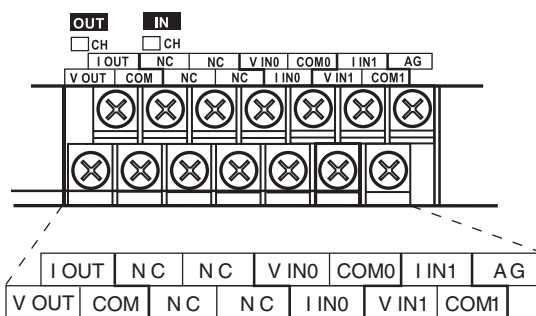

V OUT	Voltage output
I OUT	Current output
COM	Output common
V IN0	Voltage input 0
I IN0	Current input 0
COM0	Input common 0
V IN1	Voltage input 1
I IN1	Current input 1
COM1	Input common 1

Note For current inputs, short V IN0 to I IN0 and V IN1 to I IN1.

(2) Expansion I/O Connecting Cable

Connected to the expansion connector of a CPU Unit or an Expansion Unit or Expansion I/O Unit. The cable is provided with the Analog I/O Unit and cannot be removed.



Precautions for Safe Use

Do not touch the cables during operation. Static electricity may cause operating errors.

(3) Expansion Connector

Used for connecting Expansion Units or Expansion I/O Units.

(4) DIP Switch

Used to enable or disable averaging.



Pin 1: Average processing for analog input 0

(OFF: Average processing not performed; ON: Average processing performed)

Pin 2: Average processing for analog input 1

(OFF: Average processing not performed; ON: Average processing performed)

Specifications

CP1W-MAD11 Analog I/O Units are connected to the CP1E CPU Unit.

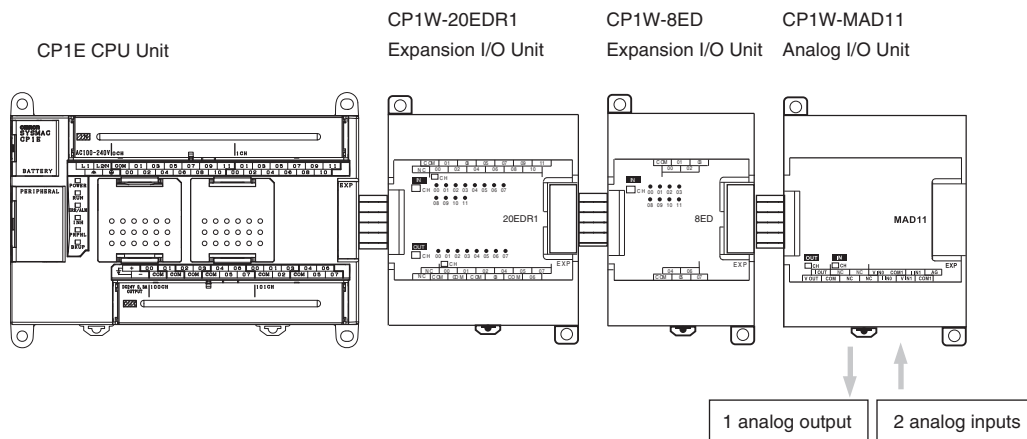

Model		CP1W-MAD11		
Item		Voltage I/O	Current I/O	
Analog Input Section	Number of analog inputs	2 inputs (2 words allocated)		
	Input signal range	0 to 5 V, 1 to 5 V, 0 to 10 V, or -10 to 10 V	0 to 20 mA or 4 to 20 mA	
	Max. rated input	±15 V	±30 mA	
	External input impedance	1 MΩ min.	Approx. 250 Ω	
	Resolution	1/6000 (full scale)		
	Overall accuracy	25°C	0.3% full scale	0.4% full scale
		0 to 55°C	0.6% full scale	0.8% full scale
	A/D conversion data	16-bit binary (4-digit hexadecimal) Full scale for -10 to 10 V: F448 to 0BB8 hex Full scale for other ranges: 0000 to 1770 hex		
	Averaging function	Supported (Settable for individual inputs via DIP switch)		
	Open-circuit detection function	Supported		
Analog Output Section	Number of outputs	1 output (1 word allocated)		
	Output signal range	1 to 5 VDC, 0 to 10 VDC, or -10 to 10 VDC	0 to 20 mA or 4 to 20 mA	
	Allowable external output load resistance	1 kΩ min.	600 Ω max.	
	External output impedance	0.5 Ω max.	—	
	Resolution	1/6000 (full scale)		
	Overall accuracy	25°C	0.4% full scale	
		0 to 55°C	0.8% full scale	
	Set data (D/A conversion)	16-bit binary (4-digit hexadecimal) Full scale for -10 to 10 V: F448 to 0BB8 hex Full scale for other ranges: 0000 to 1770 hex		
Conversion time	2 ms/point (6 ms/all points)			
Isolation method	Photocoupler isolation between analog I/O terminals and internal circuits. No isolation between analog I/O signals.			
Current consumption	5 VDC: 83 mA max., 24 VDC: 110 mA max.			

● Analog I/O Signal Ranges

Analog I/O data is digitally converted according to the analog I/O signal range as shown below.



Additional Information

When the input/output exceeds the specified range, the AD/DA converted data will be fixed at either the lower limit or upper limit.

Analog Input Signal Ranges

-10 to 10 V

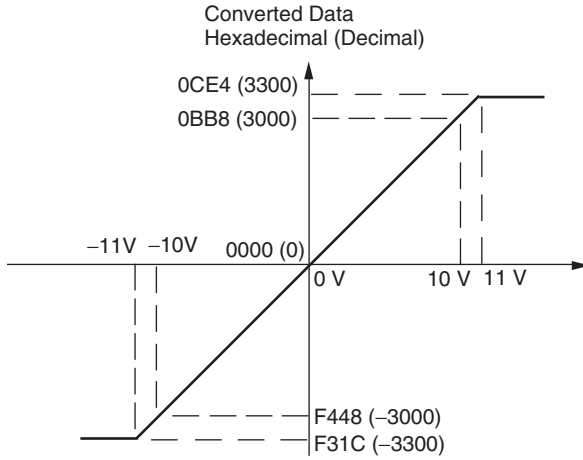

Voltages in the -10 to 10 V range correspond to hexadecimal values F448 to 0BB8 (-3,000 to 3,000). The range of data that can be converted is F31C to 0CE4 hex (-3,300 to 3,300). A negative voltage is expressed as a two's complement.

0 to 10 V

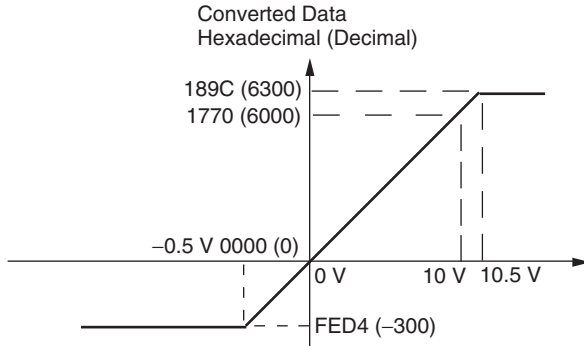

Voltages in the 0 to 10 V range correspond to hexadecimal values 0000 to 1770 (0 to 6,000). The range of data that can be converted is FED4 to 189C hex (-300 to 6,300). A negative voltage is expressed as a two's complement.

0 to 5 V

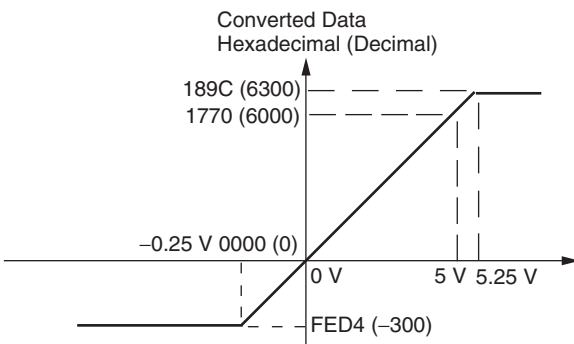

Voltages in the 0 to 5 V range correspond to hexadecimal values 0000 to 1770 (0 to 6,000). The range of data that can be converted is FED4 to 189C hex (-300 to 6,300). A negative voltage is expressed as a two's complement.

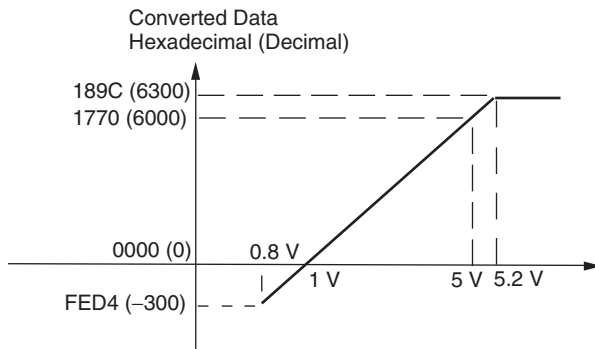
1 to 5 V

Voltages in the 1 to 5 V range correspond to hexadecimal values 0000 to 1770 (0 to 6,000). The range of data that can be converted is FED4 to 189C hex (-300 to 6,300).

Voltage in the range of 0.8 to 1 V is expressed as a two's complement.

If an input is below the range (i.e., less than 0.8 V), the open-circuit detection function is activated and the data becomes 8,000.

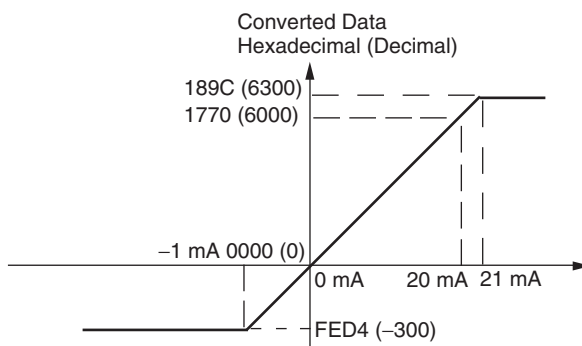
0 to 20 mA

Currents in the 0 to 20 mA range correspond to hexadecimal values 0000 to 1770 (0 to 6,000). The range of data that can be converted is FED4 to 189C hex (-300 to 6,300). A negative current is expressed as a two's complement.

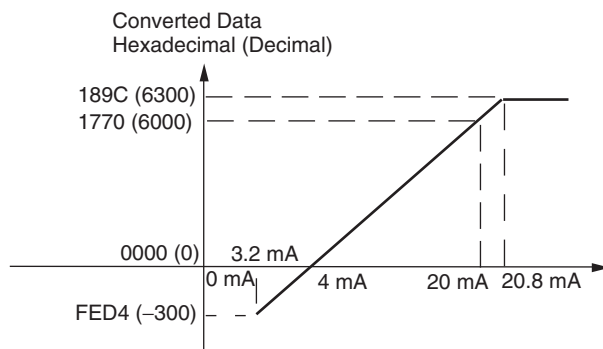
4 to 20 mA

Currents in the 4 to 20 mA range correspond to hexadecimal values 0000 to 1770 (0 to 6,000). The range of data that can be converted is FED4 to 189C hex (-300 to 6,300). Current in the range of 3.2 to 4 mA is expressed as a two's complement. If an input is below the range (i.e., less than 3.2 mA), the open-circuit detection function is activated and the data becomes 8,000.

Analog Output Signal Ranges

-10 to 10 V

The hexadecimal values F448 to 0BB8 (-3000 to 3000) correspond to an analog voltage range of -10 to 10 V.

The entire output range is -11 to 11V.

Specify the DA conversion data as the two's complement if it is a negative value.

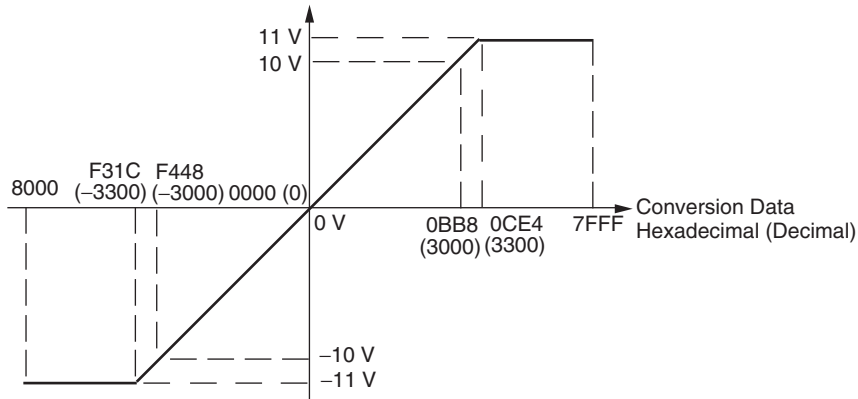

0 to 10 V

The hexadecimal values 0000 to 1770 (0 to 6000) correspond to an analog voltage range of 0 to 10 V.

The entire output range is -0.5 to 10.5 V.

Specify the DA conversion data as the two's complement if it is a negative value.

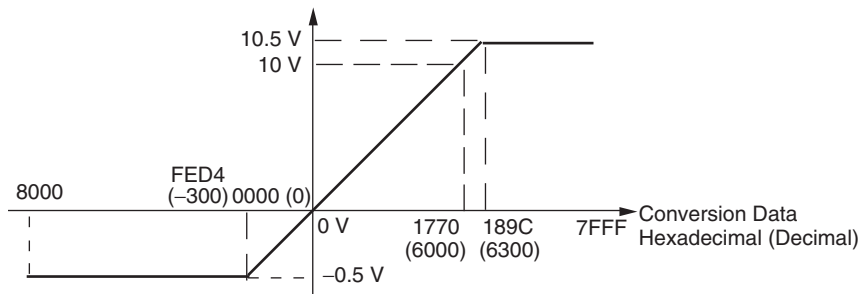

1 to 5 V

The hexadecimal values 0000 to 1770 (0 to 6000) correspond to an analog voltage range of 1 to 5 V.

The entire output range is 0.8 to 5.2 V.

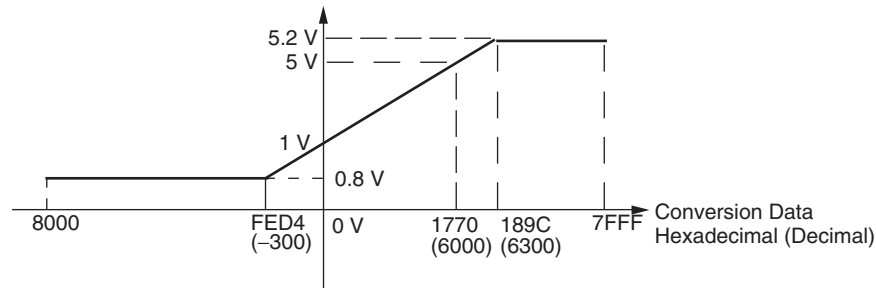

0 to 20 mA

The hexadecimal values 0000 to 1770 (0 to 6000) correspond to an analog current range of 0 to 20 mA. The entire output range is 0 to 21 mA.

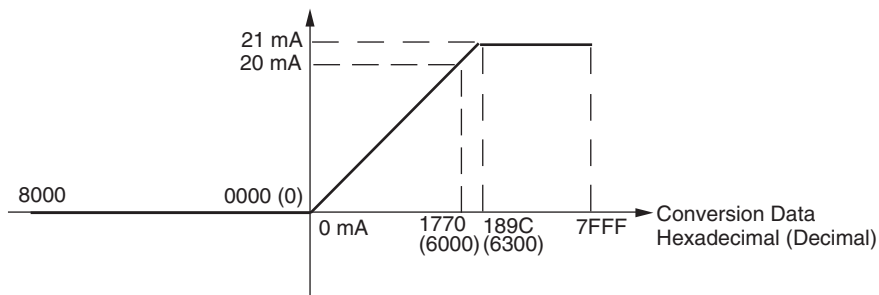
**4 to 20 mA**

The hexadecimal values 0000 to 1770 (0 to 6000) correspond to an analog current range of 4 to 20 mA. The entire output range is 3.2 to 20.8 mA.

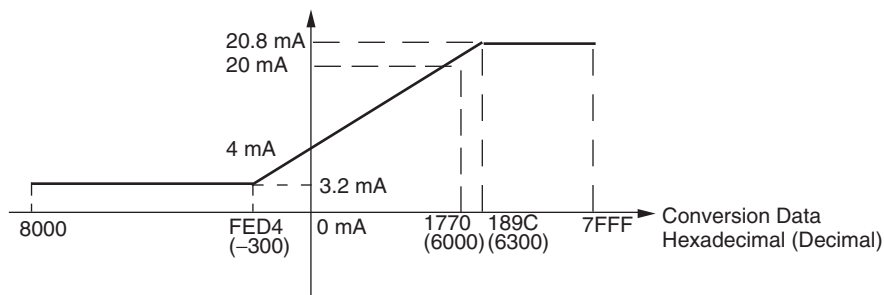

- **Averaging Function for Analog Inputs**

The averaging function can be enabled for inputs using the DIP switch. The averaging function outputs the average (a moving average) of the last eight input values as the converted value.

Use this function to smooth inputs that vary at a short interval.

- **Open-circuit Detection Function for Analog Inputs**

The open-circuit detection function is activated when the input range is set to 1 to 5 V and the voltage drops below 0.8 V, or when the input range is set to 4 to 20 mA and the current drops below 3.2 mA.

When the open-circuit detection function is activated, the converted data will be set to 8,000.

The time for enabling or clearing the open-circuit detection function is the same as the time for converting the data.

If the input returns to the convertible range, the open-circuit detection is cleared automatically and the output returns to the normal range.

Flow of Operation

- 1** Connect the Unit.
 - Connect the Analog I/O Unit.
 - Set analog inputs as voltage or current inputs and set the averaging function.
- ↓
- 2** Wire the analog I/O.
 - Connect analog I/O devices.
- ↓
- 3** Create a ladder program.
 - Write the range code.
 - Analog inputs: Read converted values.
 - Analog output: Write set data.

● Writing Set Data and Reading A/D Converted Values

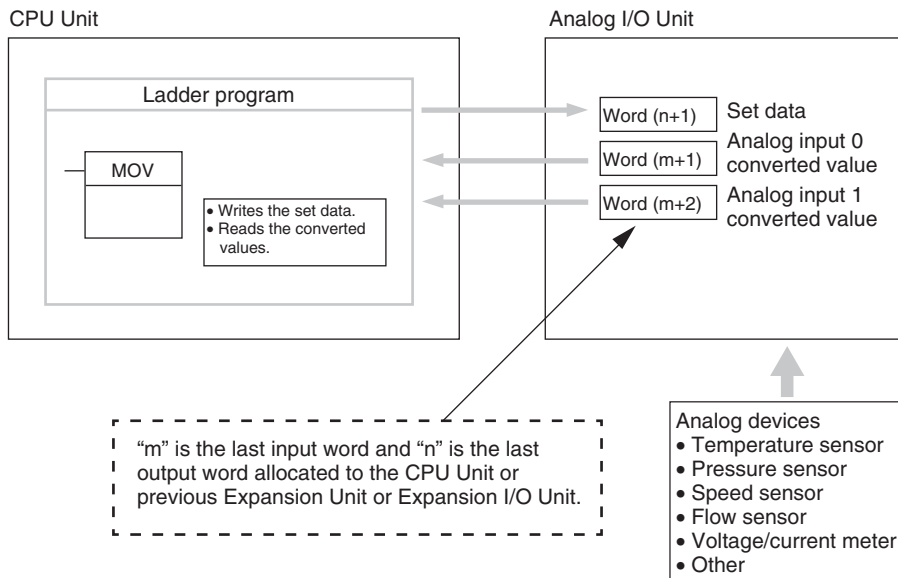

● Writing D/A Conversion Data

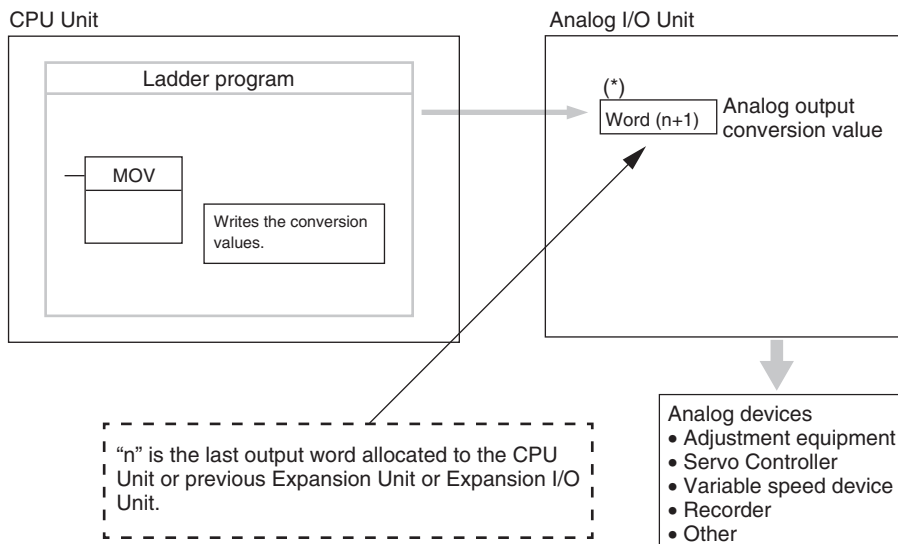

* Word (n+1) can be used for either the set data or the analog output conversion value.

1 Connect the Analog I/O Unit to the CPU Unit.

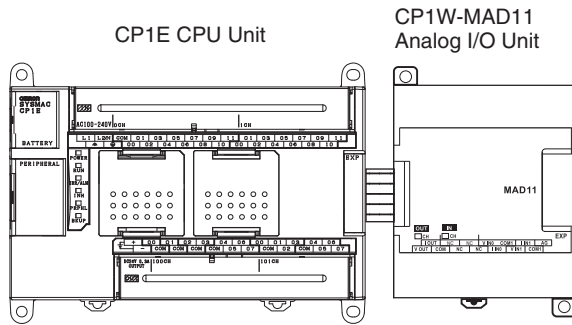

• Setting the Averaging Function

DIP switch pins 1 and 2 are used to set the averaging function. When averaging is enabled, a moving average of the last eight input values is output as the converted value. The averaging function can be set separately for analog inputs 0 and 1.



DIP switch pin	Function	Setting	Default
1	Averaging	Analog input 0 OFF: Disabled; ON: Enabled	OFF
2		Analog input 1 OFF: Disabled; ON: Enabled	OFF

2 Wire to analog I/O devices.

(1) Wiring internal circuits of the CPU Unit

• Analog Inputs

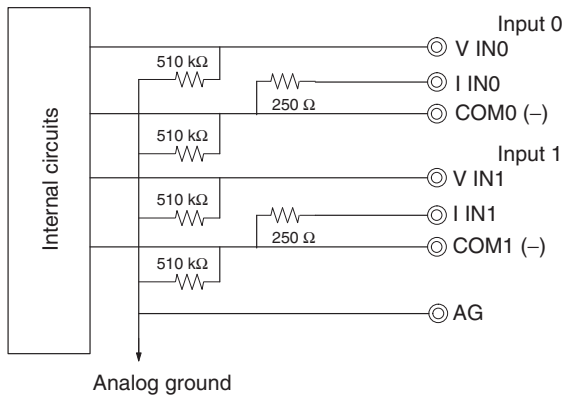

• Analog Outputs

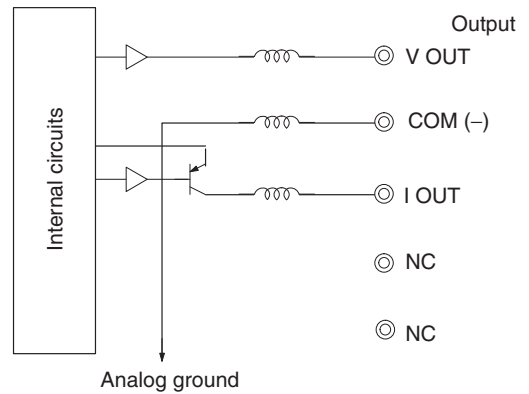

(2) Wiring analog output devices to the Analog I/O Unit

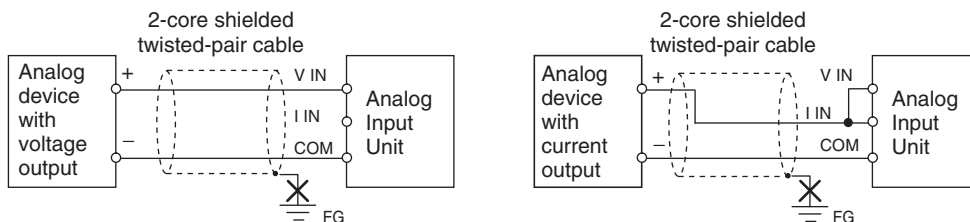

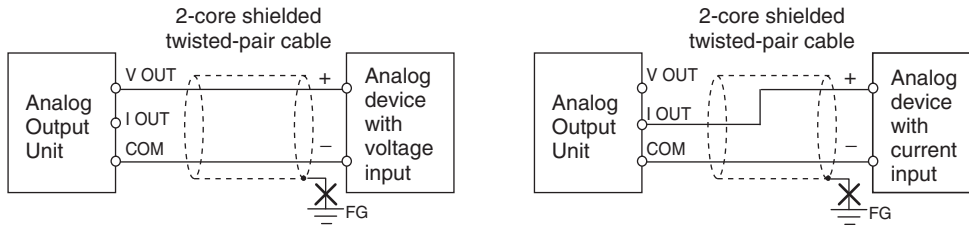
(3) Wiring analog input devices to the Analog I/O Unit**Precautions for Correct Use**

- Do not connect the shield when using shielded twisted-pair cables.
- When an input is not being used, short V IN and I IN to COM terminals.
- Separate wiring from power lines (AC power supply lines, high-voltage lines, etc.)
- When there is noise in the power supply line, install a noise filter on the input section and the power supply terminals.

**Additional Information**

Refer to the following information on open circuits when using voltage inputs.

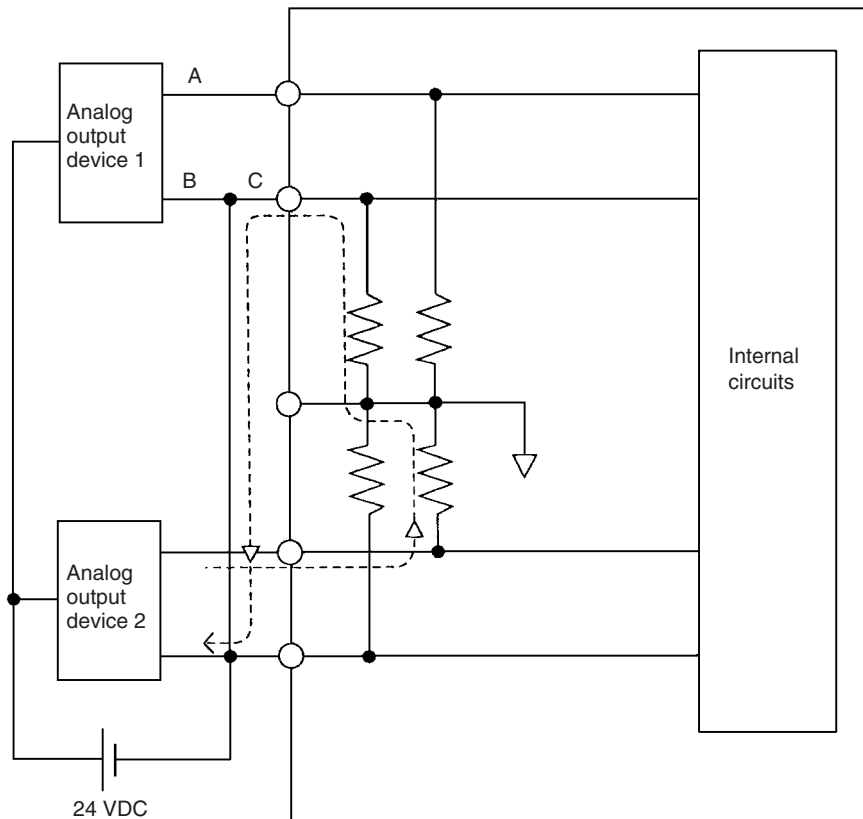

Example: If connected device 2 is outputting 5 V and the same power supply is being used for both devices as shown above, approximately 1/3, or 1.6 V, will be applied to the input for input device 1.

If a wiring disconnection occurs when voltage input is being used, the situation described below will result. Either separate the power supplies for the connected devices, or use an isolator for each input.

- If the same power supply is being used by the connected devices and a disconnection occurs at points A or B in the above diagram, an unwanted circuit path will occur as shown along the dotted line in the diagram. If that occurs, a voltage of approximately 1/3 to 1/2 of the output voltage of the other connected device will be generated.
- If that voltage is generated while the setting is for 1 to 5 V, open-circuit detection may not be possible.
- If a disconnection occurs at point C in the diagram, the negative (-) side will be used for both devices and open-circuit detection will not be possible.

This problem will not occur for current inputs even if the same power supply is used.



Additional Information

When external power is supplied (when setting the range code), or when there is a power interruption, a pulse-form analog output may be generated.

If this causes problems with operation, take countermeasures such as those suggested below.

(1) Countermeasure 1

- Turn ON the power supply for the CP1E CPU Unit first, confirm correct operation, and then turn ON the power supply for the load.
- Turn OFF the power supply for the load before turning OFF the power supply for the CP1E CPU Unit.

(2) Countermeasure 2

- Control the machine not only by analog output but also by other signals (additional start/stop control signal for machine).

3 Create the ladder program.

(1) Allocating I/O Words

Two input words and one output word are allocated to the Analog I/O Unit starting from the next word following the last word allocated to the CPU Unit or previous Expansion Unit or Expansion I/O Unit.

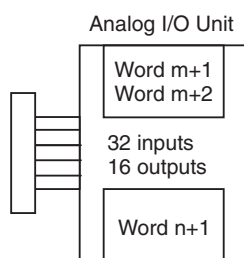

(2) Writing the Set Data

Write the set data to word n+1. A/D or D/A conversion begins when the set data is transferred from the CPU Unit to the Analog I/O Unit. There are five range codes, 000 to 100, that combine the analog input 0 and 1 and analog output ranges, as shown below.

Range code	Analog input 0 range	Analog input 1 range	Analog output range
000	-10 to 10 V	-10 to 10 V	-10 to 10 V
001	0 to 10 V	0 to 10 V	0 to 10 V
010	1 to 5 V/4 to 20 mA	1 to 5 V/4 to 20 mA	1 to 5 V
011	0 to 5 V/0 to 20 mA	0 to 5 V/0 to 20 mA	0 to 20 mA
100	—	—	4 to 20 mA

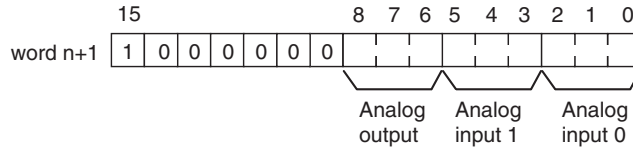

Example: The following instructions set analog input 0 to 4 to 20 mA, analog input 1 to 0 to 10 V, and the analog output to -10 to 10 V.

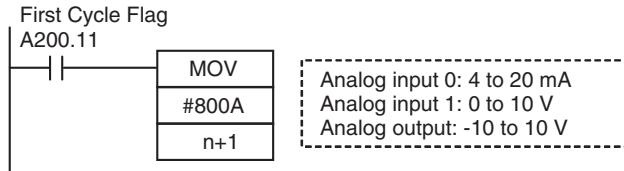

- The Analog I/O Unit will not start converting analog I/O values until the range code has been written. Inputs will be 0000, and 0 V or 0 mA will be output.
- After the range code has been set, 0 V or 0 mA will be output for the 0 to 10V, -10 to 10V, or 0 to 20mA ranges, and 1 V or 4 mA will be output for the 1 to 5V and 4 to 20mA ranges until a convertible value has been written to the output word.
- Once the range code has been set, it is not possible to change the setting while power is being supplied to the CPU Unit. To change the I/O range, turn the CPU Unit OFF then ON again.

(3) Reading Analog Input Converted Values

The ladder program can be used to read the memory area words where the converted values are stored.

Values are output to the next two words (m + 1, m + 2) following the last input word (m) allocated to the CPU Unit or previous Expansion Unit or Expansion I/O Unit.

(4) Writing Analog Output Converted Values

The ladder program can be used to write data to the memory area where the set value is stored.

The output word will be “n+1”, where “n” is the last output word allocated to the CPU Unit or previous Expansion Unit or Expansion I/O Unit.

(5) Startup Operation

After the power is turned ON, it will require two cycle times plus approximately 50 ms before the first conversion data is stored in the input words. Therefore, create a program as shown below, so that when operation begins simultaneously with startup it will wait for valid conversion data.

Analog input data will be 0000 until initial processing is completed. Analog output data will be 0 V or 0 mA until the range code has been written. After the range code has been written, the analog output data will be 0 V or 0 mA if the range is 0 to 10 V, -10 to 10 V, or 0 to 20 mA, or it will be 1 V or 4 mA if the range is 1 to 5 V or 4 to 20 mA.

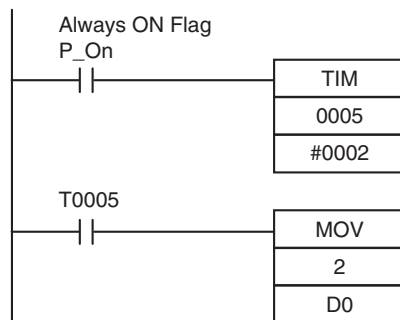

TIM0005 is started when the power is turned ON. After 0.2 s (200 ms) elapses, the TIM0005 contact turns ON and the converted data from analog input 0 that is stored in CIO 2 will be transferred to D0.

(6) Handling Unit Errors

- When an error occurs in the Analog I/O Unit, analog input data will be 0000 and 0 V or 0 mA will be output as the analog output.
If a CPU error or an I/O bus error (fatal errors) occurs at the CPU Unit and the analog output is set to 1 to 5 V or 4 to 20 mA, 0 V or 0 mA will be output. For any other fatal errors at the CPU Unit, 1 V or 4 mA will be output.
- Expansion Unit and Expansion I/O Unit errors are output to bits 0 to 5 of word A436. The bits are allocated from A436.00 in order starting from the Unit nearest the CPU Unit. Use these flags in the program when it is necessary to detect errors.

(7) Programming Example

Analog input 0: 0 to 10 V

Analog input 1: 4 to 20 mA

Analog output : 0 to 10 V

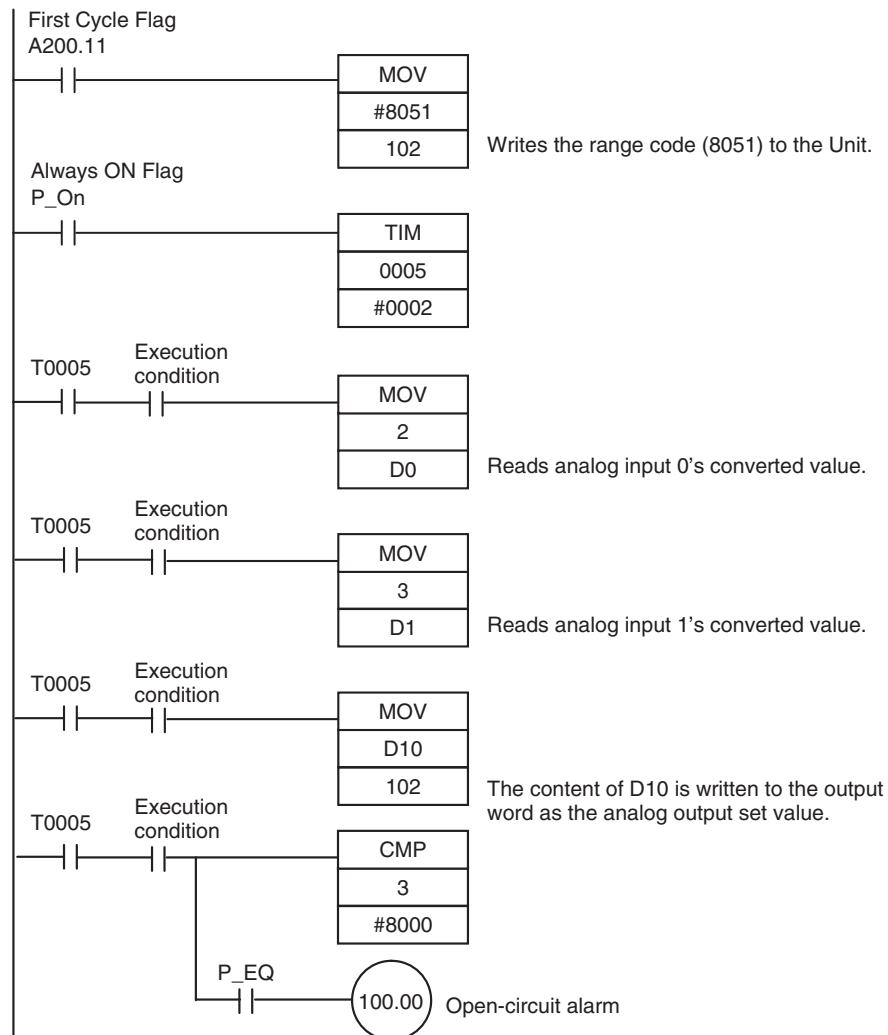

8-3-2 CP1W-MAD42/CP1W-MAD44 Analog I/O Units

Overview

Each CP1W-MAD42 Analog I/O Unit provides 4 analog inputs and 2 analog outputs.

Each CP1W-MAD44 Analog I/O Unit provides 4 analog inputs and 4 analog outputs.

- The analog input range can be set to 0 to 5 VDC, 1 to 5 VDC, 0 to 10 VDC, -10 to 10 VDC, 0 to 20 mA, or 4 to 20 mA. The inputs have a resolution of 1/12000. An open-circuit detection function is activated in the ranges of 1 to 5 VDC and 4 to 20 mA.
- The analog output range can be set to 1 to 5 VDC, 0 to 10 VDC, -10 to 10 VDC, 0 to 20 mA, or 4 to 20 mA. The outputs have a resolution of 1/12000.

Part Names and Functions

● CP1W-MAD42/CP1W-MAD44

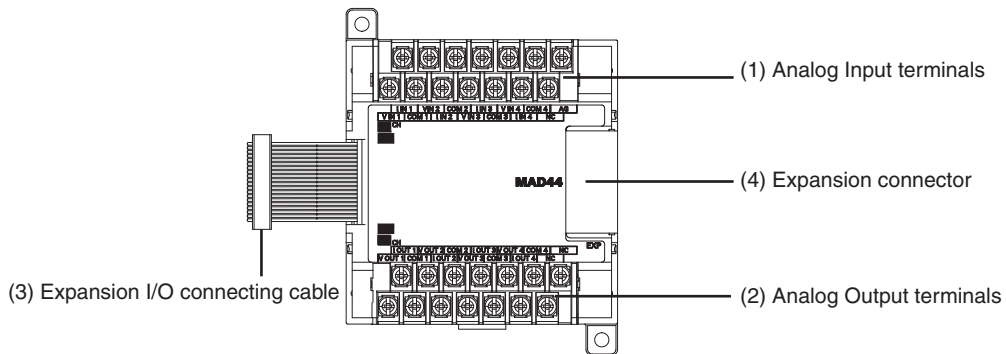

(1) Analog Input Terminals
Connected to analog output devices.

- Input Terminal Arrangement for CP1W-MAD42/MAD44

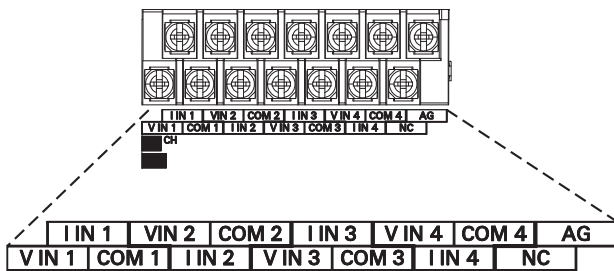

V IN1	Voltage input 1
I IN1	Current input 1
COM1	Input common 1
V IN2	Voltage input 2
I IN2	Current input 2
COM2	Input common 2
V IN3	Voltage input 3
I IN3	Current input 3
COM3	Input common 3
V IN4	Voltage input 4
I IN4	Current input 4
COM4	Input common 4

Note When using current inputs, voltage input terminals must be short-circuited with current input terminals.

(2) Analog Output Terminals
Connected to analog input devices.

- Output Terminal Arrangement for CP1W-MAD42

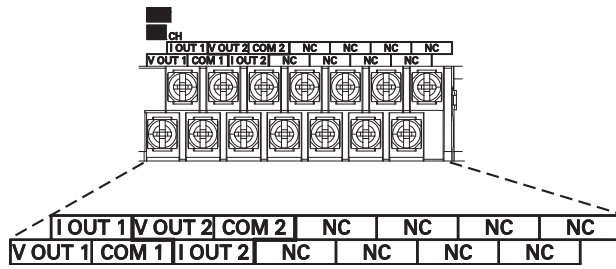

V OUT1	Voltage output 1
I OUT1	Current output 1
COM1	Output common 1
V OUT2	Voltage output 2
I OUT2	Current output 2
COM2	Output common 2

- Output Terminal Arrangement for CP1W-MAD44

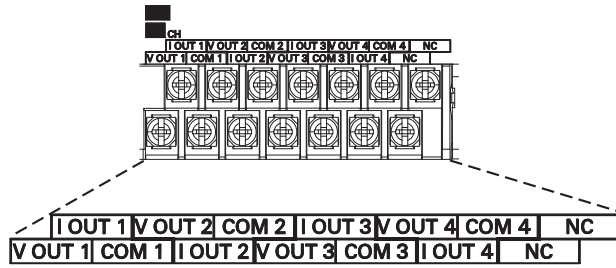

V OUT1	Voltage output 1
I OUT1	Current output 1
COM1	Output common 1
V OUT2	Voltage output 2
I OUT2	Current output 2
COM2	Output common 2
V OUT3	Voltage output 3
I OUT3	Current output 3
COM3	Output common 3
V OUT4	Voltage output 4
I OUT4	Current output 4
COM4	Output common 4

(3)Expansion I/O Connecting Cable

Connected to the expansion connector of a CPU Unit or an Expansion Unit or Expansion I/O Unit. The cable is provided with the Analog I/O Unit and cannot be removed.



Precautions for Safe Use

Do not touch the cables during operation. Static electricity may cause operating errors.

(4)Expansion Connector

Used for connecting Expansion Units or Expansion I/O Units.

Specifications

CP1W-MAD42/MAD44 Analog I/O Units are connected to the CP1E CPU Unit.

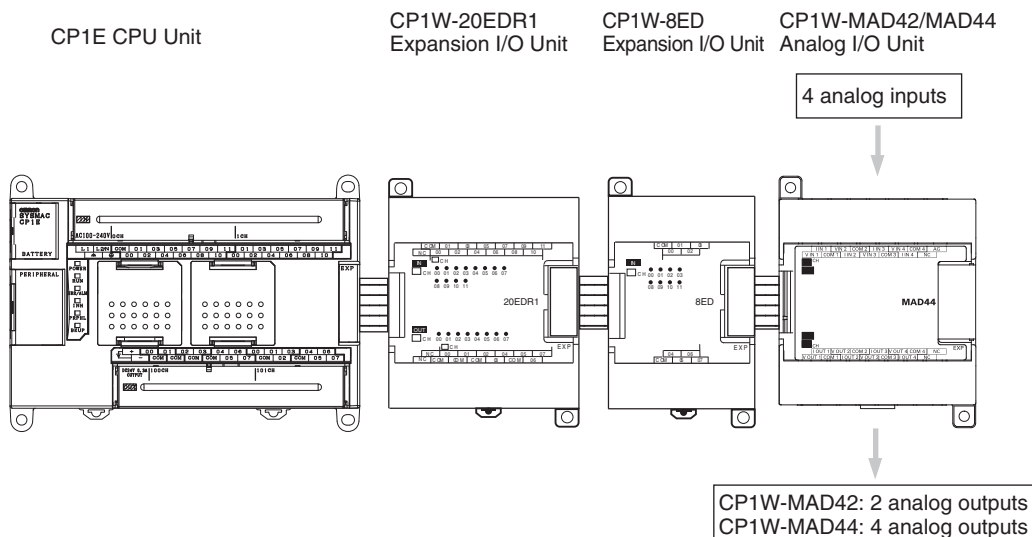

Model		CP1W-MAD042/CP1W-MAD044		
Item		Voltage I/O	Current I/O	
Analog Input Section	Number of inputs	4 inputs (4 words allocated)		
	Input signal range	0 to 5 VDC, 1 to 5 VDC, 0 to 10 VDC, or -10 to 10 VDC	0 to 20 mA or 4 to 20 mA	
	Max. rated input	±15 V	±30 mA	
	External input impedance	1 MΩ min.	Approx. 250 Ω	
	Resolution	1/12000 (full scale)		
	Overall accuracy	25°C	0.2% full scale	0.3% full scale
		0 to 55°C	0.5% full scale	0.7% full scale
	A/D conversion data	16-bit binary (4-digit hexadecimal) Full scale for -10 to 10 V: E890 to 1770 hex Full scale for other ranges: 0000 to 2EE0 hex		
	Averaging function	Supported		
Open-circuit detection function	Supported			
Analog Output Section	Number of outputs	CP1W-MAD42: 2 outputs (2 words allocated) CP1W-MAD44: 4 outputs (4 words allocated)		
	Output signal range	1 to 5 VDC, 0 to 10 VDC, or -10 to 10 VDC	0 to 20 mA or 4 to 20 mA	
	Allowable external output load resistance	2 kΩ min.	350 Ω max.	
	External output impedance	0.5 Ω max.		
	Resolution	1/12000 (full scale)		
	Overall accuracy	25°C	0.3% full scale	
		0 to 55°C	0.7% full scale	
Set data (D/A conversion)	16-bit binary (4-digit hexadecimal) Full scale for -10 to 10 V: E890 to 1770 hex Full scale for other ranges: 0000 to 2EE0 hex			
Conversion time	CP1W-MAD42: 1 ms/point (6 ms/all points) CP1W-MAD44: 1 ms/point (8 ms/all points)			
Isolation method	Photocoupler isolation between analog I/O terminals and internal circuits. No isolation between analog I/O signals.			
Current consumption	CP1W-MAD42: 5 VDC: 120 mA max., 24 VDC: 120 mA max. CP1W-MAD44: 5 VDC: 120 mA max., 24 VDC: 170 mA max.			

● Analog I/O Signal Ranges

Analog I/O data is digitally converted according to the analog I/O signal range as shown below.



Additional Information

When the input/output exceeds the specified range, the AD/DA converted data will be fixed at either the lower limit or upper limit.

Analog Input Signal Ranges

-10 to 10 V

The -10 to 10 V range corresponds to the hexadecimal values E890 to 1770 (-6000 to 6000). The entire data range is E638 to 19C8 (-6600 to 6600). A negative voltage is expressed as a two's complement.

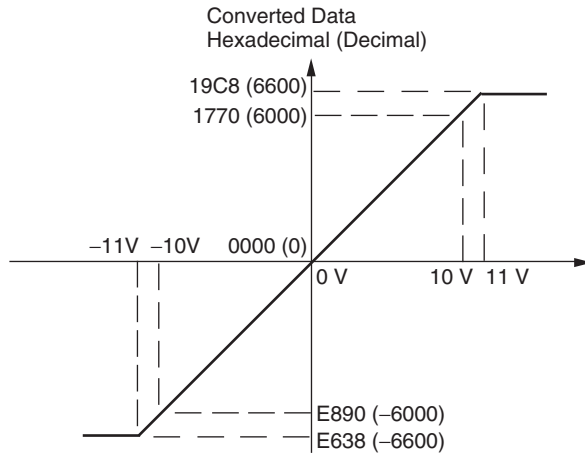

0 to 10 V

The 0 to 10 V range corresponds to the hexadecimal values 0000 to 2EE0 (0 to 12000). The entire data range is FDA8 to 3138 (-600 to 12600). A negative voltage is expressed as a two's complement.

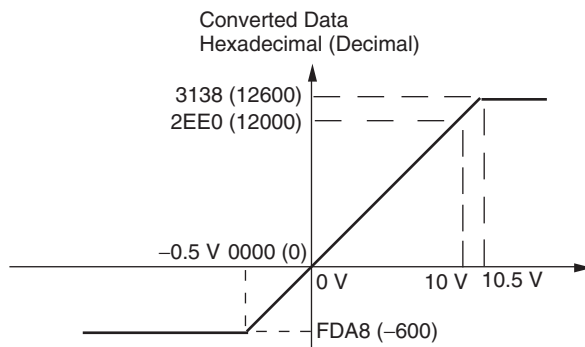

0 to 5 V

The 0 to 5 V range corresponds to the hexadecimal values 0000 to 2EE0 (0 to 12000). The entire data range is FDA8 to 3138 (-600 to 12600). A negative voltage is expressed as a two's complement.

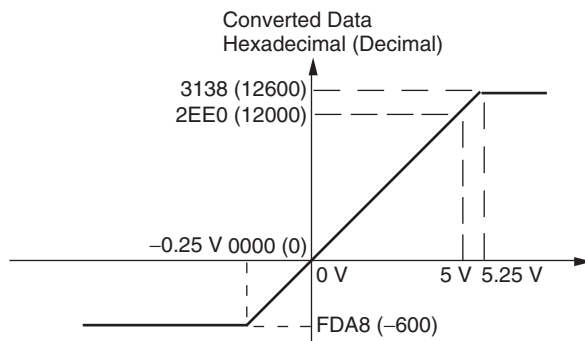

1 to 5 V

The 1 to 5 V range corresponds to the hexadecimal values 0000 to 2EE0 (0 to 12000). The entire data range is FDA8 to 3138 (-600 to 12600). Inputs between 0.8 and 1 V are expressed as two's complements. If the input falls below 0.8 V, open-circuit detection will activate and converted data will be 8000.

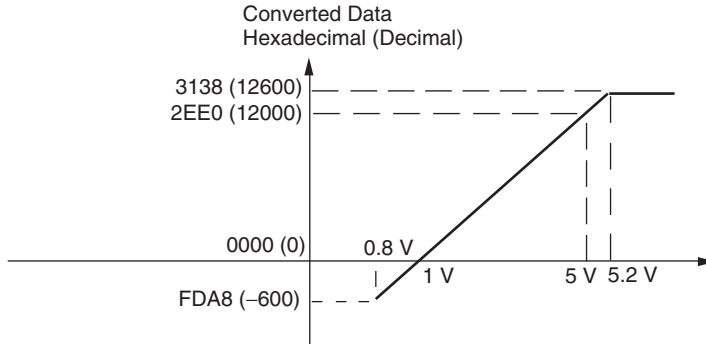

0 to 20 mA

The 0 to 20 mA range corresponds to the hexadecimal values 0000 to 2EE0 (0 to 12000). The entire data range is FDA8 to 3138 (-600 to 12600). A negative current is expressed as a two's complement.

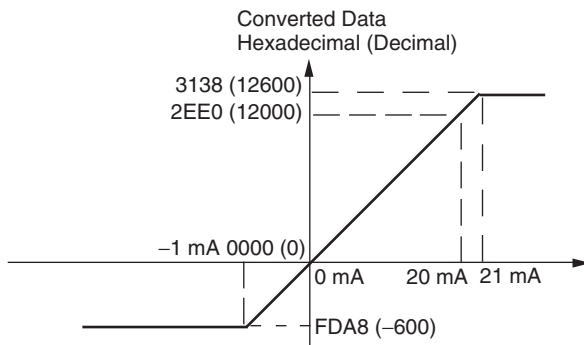

4 to 20 mA

The 4 to 20 mA range corresponds to the hexadecimal values 0000 to 2EE0 (0 to 12000). The entire data range is FDA8 to 3138 (-600 to 12600). Inputs between 3.2 and 4 mA are expressed as two's complements. If the input falls below 3.2 mA, open-circuit detection will activate and converted data will be 8000.

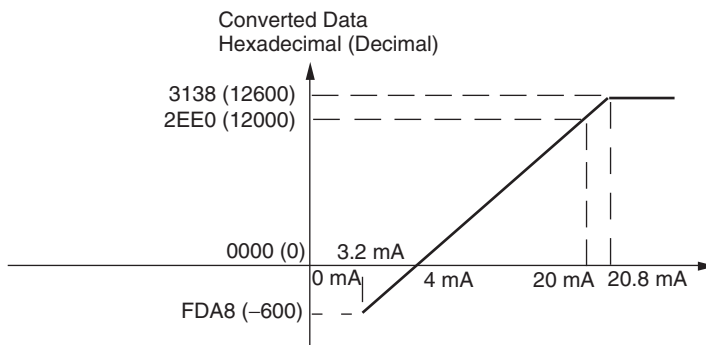

Analog Output Signal Ranges

-10 to 10 V

The hexadecimal values E890 to 1770 (-6000 to 6000) correspond to an analog voltage range of -10 to 10 V. The entire output range is -11 to 11 V. Specify a negative voltage as a two's complement.

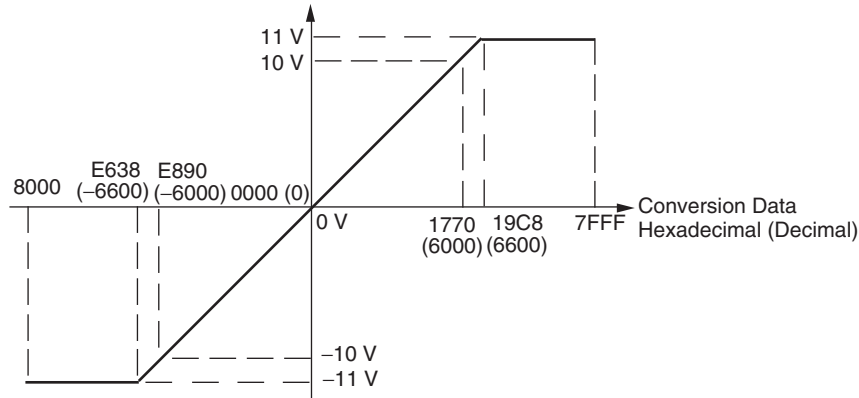

0 to 10 V

The hexadecimal values 0000 to 2EE0 (0 to 12000) correspond to an analog voltage range of 0 to 10 V. The entire output range is -0.5 to 10.5 V. Specify a negative voltage as a two's complement.

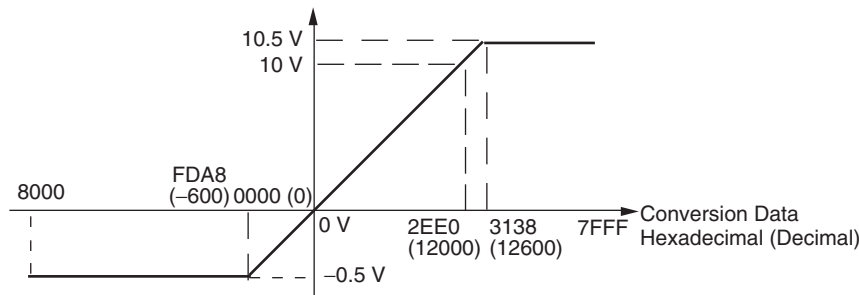

1 to 5 V

The hexadecimal values 0000 to 2EE0 (0 to 12000) correspond to an analog voltage range of 1 to 5 V. The entire output range is 0.8 to 5.2 V.

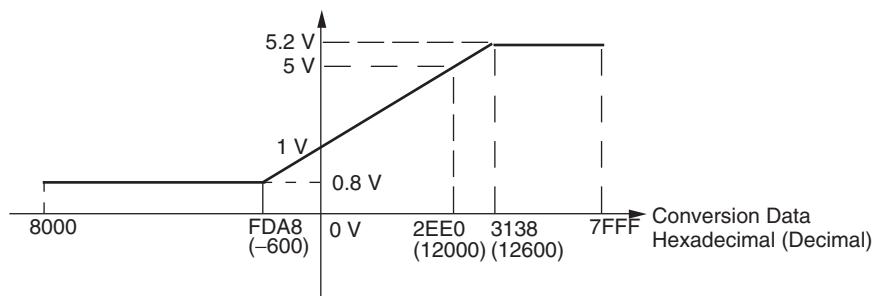

0 to 20 mA

The hexadecimal values 0000 to 2EE0 (0 to 12000) correspond to an analog current range of 0 to 20 mA. The entire output range is 0 to 21 mA.

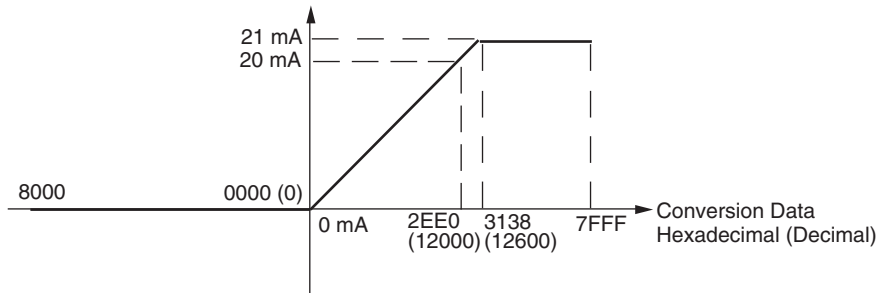
**4 to 20 mA**

The hexadecimal values 0000 to 2EE0 (0 to 12000) correspond to an analog current range of 4 to 20 mA. The entire output range is 3.2 to 20.8 mA.

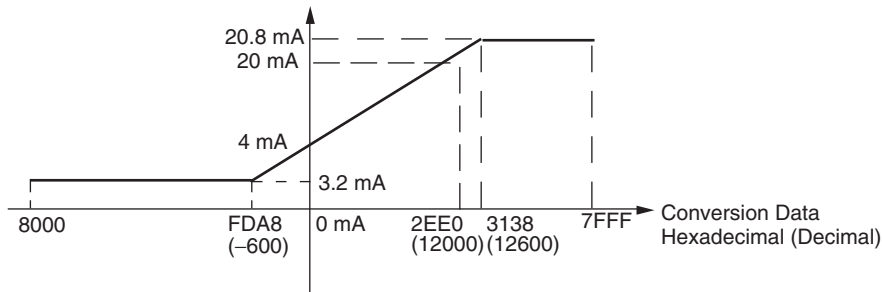

- **Averaging Function for Analog Inputs**

For analog inputs, the averaging function operates when the averaging bit is set to 1. The averaging function outputs the average (a moving average) of the last eight input values as the converted value. If there is only a slight variation in inputs, it is handled by the averaging function as a smooth input.

The averaging function stores the average (a moving average) of the last eight input values as the converted value. Use this function to smooth inputs that vary at a short interval.

- **Open-circuit Detection Function for Analog Inputs**

The open-circuit detection function is activated when the input range is set to 1 to 5 V and the voltage drops below 0.8 V, or when the input range is set to 4 to 20 mA and the current drops below 3.2 mA. When the open-circuit detection function is activated, the converted data will be set to 8,000.

The time for enabling or clearing the open-circuit detection function is the same as the time for converting the data. If the input returns to the convertible range, the open-circuit detection is cleared automatically and the output returns to the normal range.

Flow of Operation

- 1** Connect the Unit.
 - Connect the Analog I/O Unit.
 - Set analog inputs as voltage or current inputs and set the averaging function.
- ↓
- 2** Wire the analog I/O.
 - Connect analog I/O devices.
- ↓
- 3** Create a ladder program.
 - Write the range code.
 - Analog inputs: Read converted values.
 - Analog output: Write set data.

● Writing Set Data and Reading A/D Converted Data

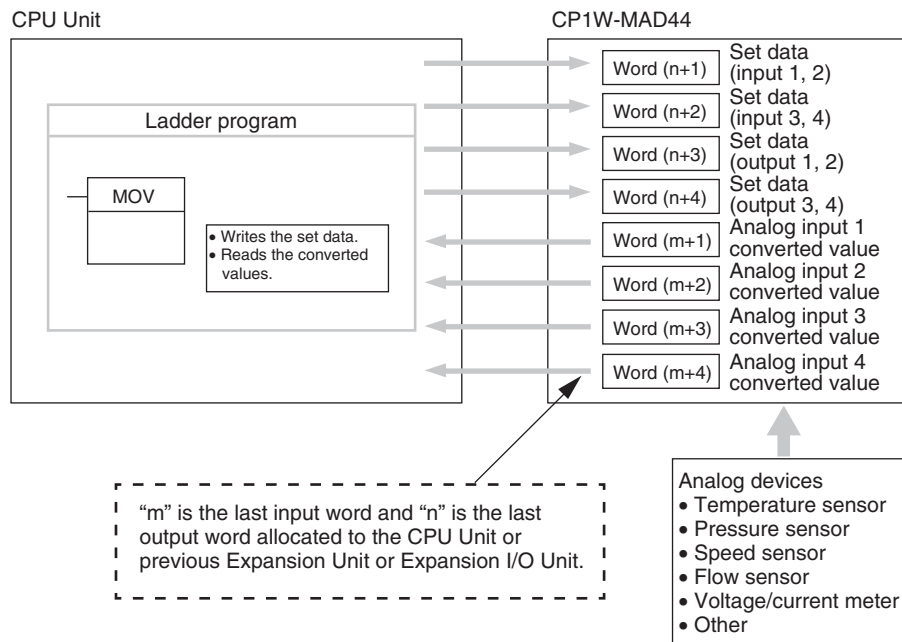
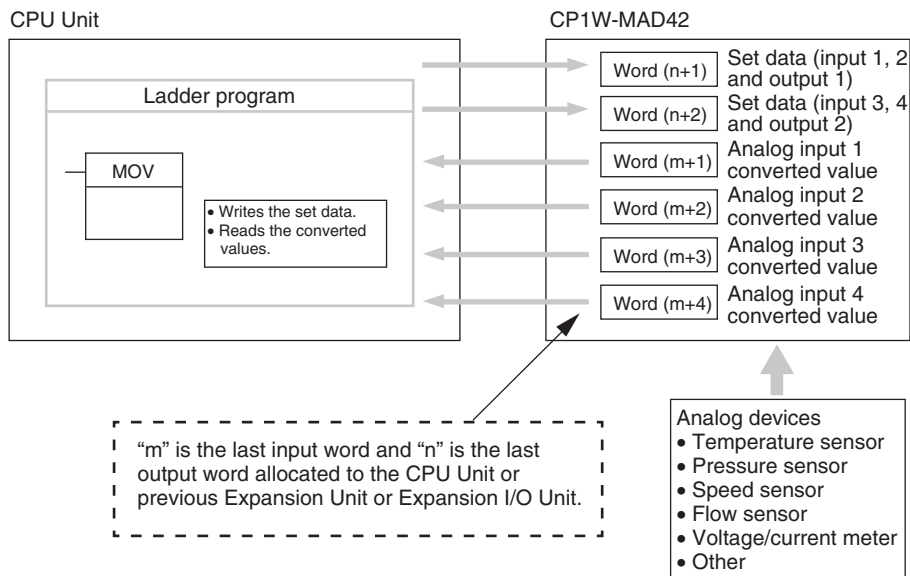

● Writing D/A Conversion Data

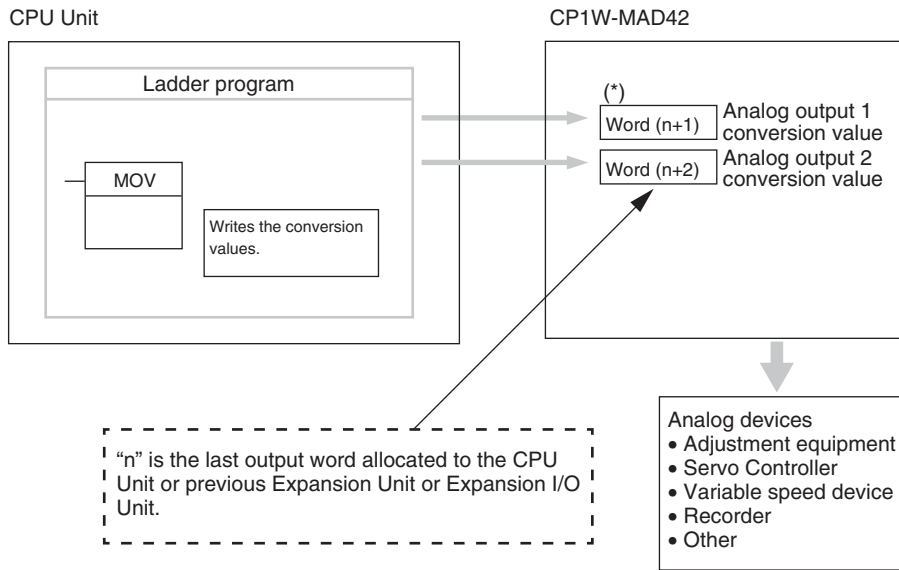

* Words (n+1, n+2) can be used for either the set data or the analog output conversion value.

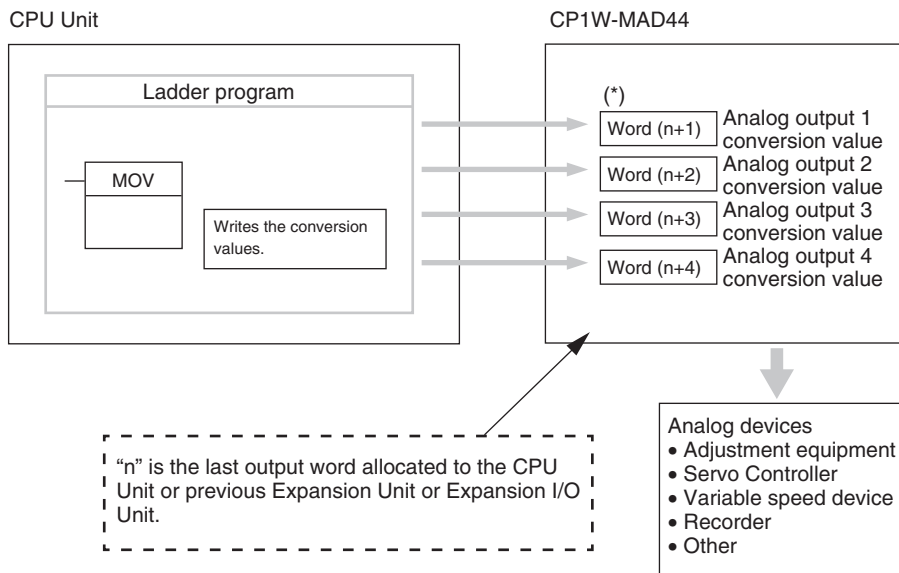

* Words (n+1 to n+4) can be used for either the set data or the analog output conversion value.

1 Connect the Analog I/O Unit to the CPU Unit.

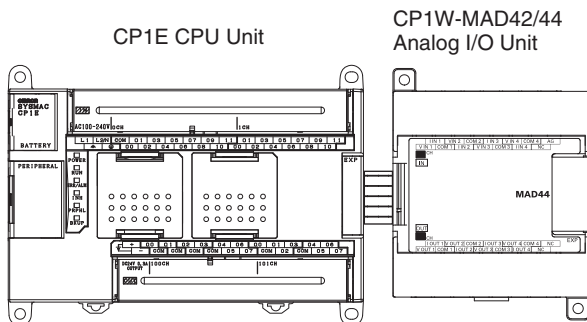

2 Wire to analog I/O devices.

(1) Wiring internal circuits of the CPU Unit

Analog Inputs

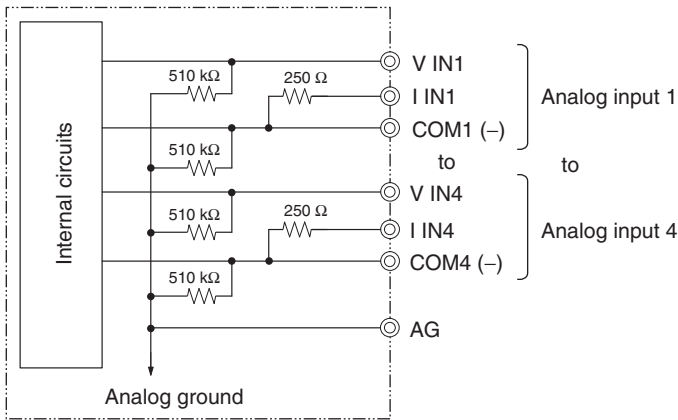

Analog Outputs (CP1W-MAD42)

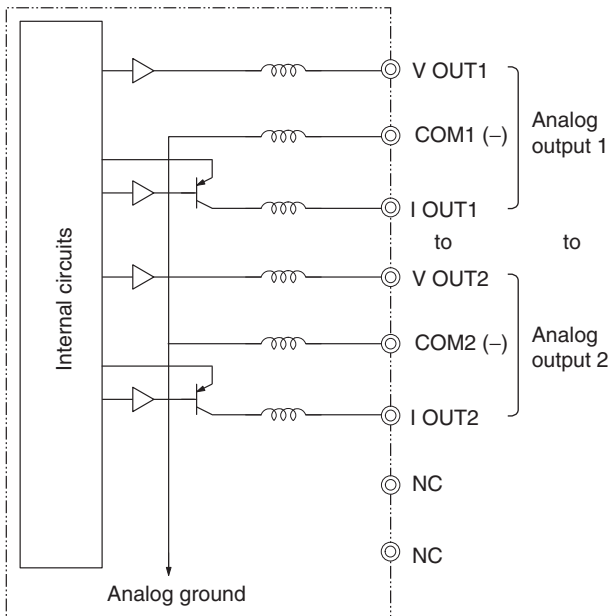

Analog Outputs (CP1W-MAD44)

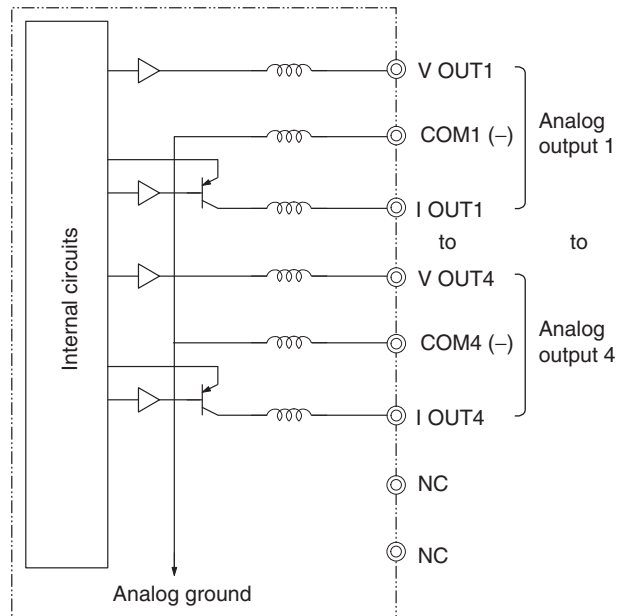

(2) Wiring analog output devices to the Analog I/O Unit

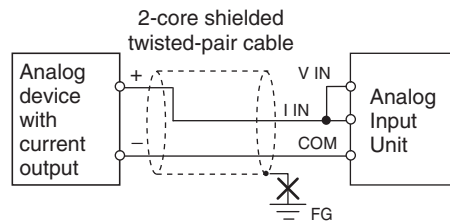
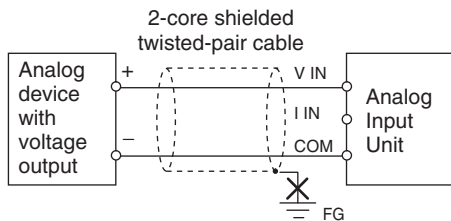

(3) Wiring analog input devices to the Analog I/O Unit

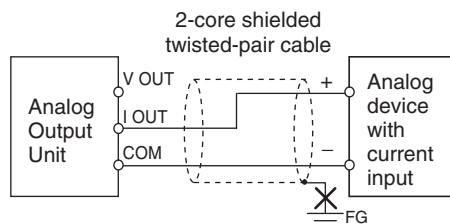
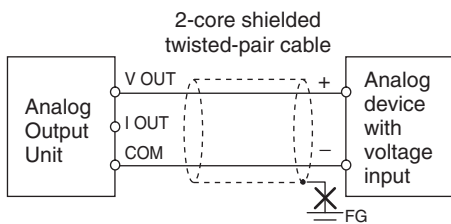



Precautions for Correct Use

- Do not connect the shield when using shielded twisted-pair cables.
- When an input is not being used, short V IN and I IN to COM terminals.
- Separate wiring from power lines (AC power supply lines, high-voltage lines, etc.)
- When there is noise in the power supply line, install a noise filter on the input section and the power supply terminals.



Additional Information

Refer to the following information on open circuits when using voltage inputs.

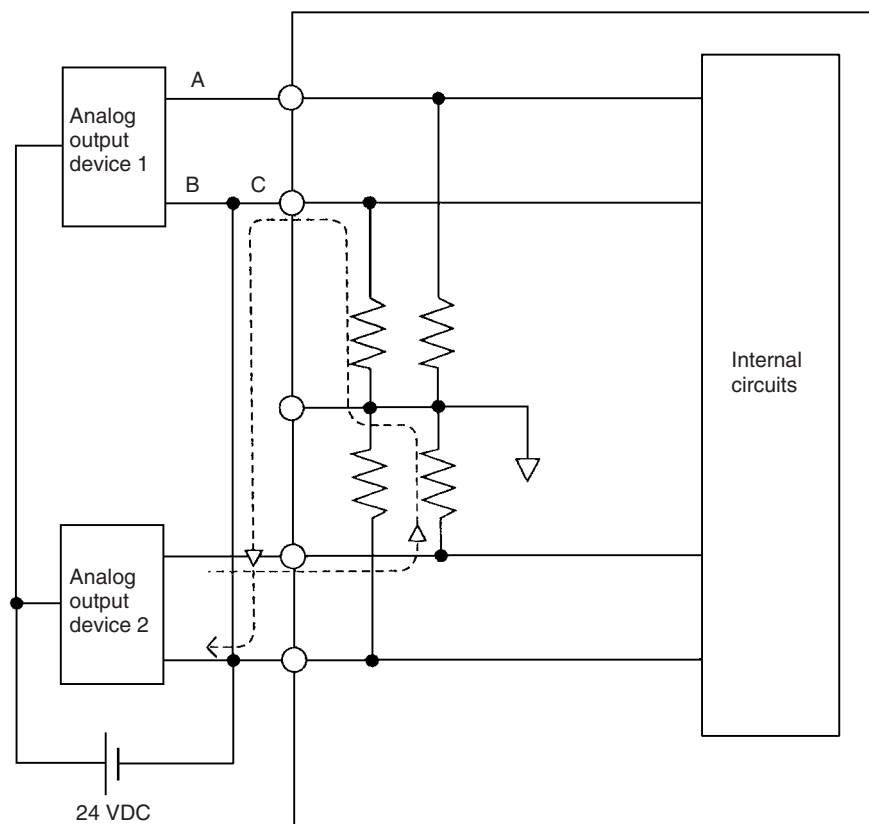

Example: If connected device 2 is outputting 5 V and the same power supply is being used for both devices as shown above, approximately 1/3, or 1.6 V, will be applied to the input for input device 1.

If a wiring disconnection occurs when voltage input is being used, the situation described below will result. Either separate the power supplies for the connected devices, or use an isolator for each input.

- If the same power supply is being used by the connected devices and a disconnection occurs at points A or B in the above diagram, an unwanted circuit path will occur as shown along the dotted line in the diagram. If that occurs, a voltage of approximately 1/3 to 1/2 of the output voltage of the other connected device will be generated.
- If that voltage is generated while the setting is for 1 to 5 V, open-circuit detection may not be possible.
- If a disconnection occurs at point C in the diagram, the negative (-) side will be used for both devices and open-circuit detection will not be possible.

This problem will not occur for current inputs even if the same power supply is used.



Additional Information

When external power is supplied (when setting the range code), or when there is a power interruption, a pulse-form analog output may be generated.

If this causes problems with operation, take countermeasures such as those suggested below.

(1) Countermeasure 1

- Turn ON the power supply for the CP1E CPU Unit first, confirm correct operation, and then turn ON the power supply for the load.
- Turn OFF the power supply for the load before turning OFF the power supply for the CP1E CPU Unit.

(2) Countermeasure 2

- Control the machine not only by analog output but also by other signals (additional start/stop control signal for machine).

3 Create the ladder program.

(1) Allocating I/O Words

Four input words and two output words are allocated to the CP1W-MAD42, starting from the next word following the last word allocated to the CPU Unit or previous Expansion Unit or Expansion I/O Unit.

Four input words and four output words are allocated to the CP1W-MAD44, starting from the next word following the last word allocated to the CPU Unit or previous Expansion Unit or Expansion I/O Unit.

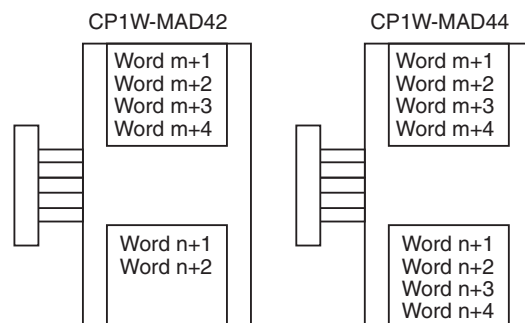

(2) Writing the Range Code

(a) CP1W-MAD42

Write the set data to words (n+1 to n+2). A/D or D/A conversion begins when the set data is transferred from the CPU Unit to the Analog I/O Unit. Setting contents are shown as the following table.

Word (n+1)	15	14	13	12	11	10	9	8	7	6	5	4	3	2	1	0
Value	1	0	0	0	Analog output 1				Analog input 2				Analog input 1			
Word (n+2)	15	14	13	12	11	10	9	8	7	6	5	4	3	2	1	0
Value	1	0	0	0	Analog output 2				Analog input 4				Analog input 3			

(b) CP1W-MAD44

Write the set data to words (n+1 to n+4). A/D or D/A conversion begins when the set data is transferred from the CPU Unit to the Analog I/O Unit. Setting contents are shown as the following table.

Word (n+1)	15	14	13	12	11	10	9	8	7	6	5	4	3	2	1	0
Value	1	0	0	0	0	0	0	0	Analog input 2				Analog input 1			
Word (n+2)	15	14	13	12	11	10	9	8	7	6	5	4	3	2	1	0
Value	1	0	0	0	0	0	0	0	Analog input 4				Analog input 3			
Word (n+3)	15	14	13	12	11	10	9	8	7	6	5	4	3	2	1	0
Value	1	0	0	0	0	0	0	0	Analog output 2				Analog output 1			
Word (n+4)	15	14	13	12	11	10	9	8	7	6	5	4	3	2	1	0
Value	1	0	0	0	0	0	0	0	Analog output 4				Analog output 3			

Even if analog inputs are not used, bit 15 in word (n+1) and (n+2) must be set to 1.

• Set Data of Analog Inputs

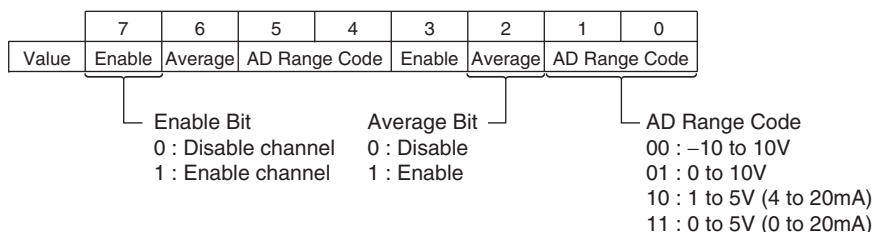

Range Code	Analog input range
00	-10 to 10 V
01	0 to 10 V
10	1 to 5 V (4 to 20 mA)
11	0 to 5 V (0 to 20 mA)

• Set Data of Analog Outputs

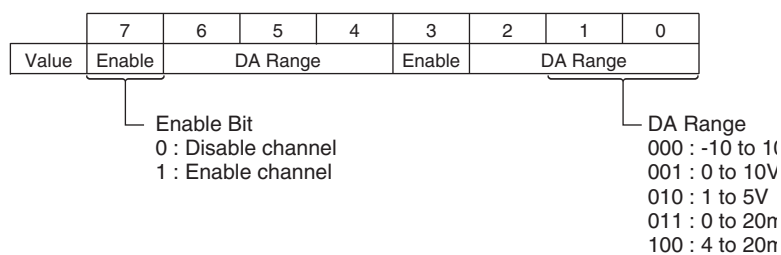

Range Code	Analog output range
000	-10 to 10 V
001	0 to 10 V
010	1 to 5 V
011	0 to 20 mA
100	4 to 20 mA

- The Analog I/O Unit will not start converting analog I/O values until the set data has been written.
- Before range code is written, 0 V or 0 mA will be output in the 0 to 10 V, -10 to +10 V, and 0 to 20 mA ranges, and 1 V or 4 mA will be output in the 1 to 5 V and 4 to 20 mA ranges.
- Once the range code has been set, it is not possible to be changed while power is being supplied to the CPU Unit. To change the code range, turn the CPU Unit OFF then ON again.

(3) Averaging

Set whether averaging is to be used for set data. When the averaging bit is set to 1, the average (moving average) for the past eight inputs is output as conversion data.

(4) Reading Analog Input Converted Values

Read the conversion value storage area with the ladder program. With word *m* as the last input word allocated to the CPU Unit or an already-connected Expansion Unit, the A/D conversion data will be output to the following words *m*+1 to *m*+4.

(5) Writing Analog Output Converted Values

The ladder program can be used to write conversion data to the output words. The output word start from “*n*+1” where “*n*” is the last output word allocated to the CPU Unit, or previous Expansion Unit or Expansion I/O Unit.

(6) Startup Operation

After power is turned ON, it will require two cycle times plus approximately 50ms before the first conversion data is output.

Analog input data will be 0000 until the first conversion data is stored in the input words.

The following table shows the output status after the initial processing is completed.

Output type	Voltage output		Current output	
Output range	0 to 10 V, -10 to +10 V	1 to 5 V	0 to 20 mA	4 to 20 mA
Before range code is written	0V		0mA	
After range code is written	0V	1V	0mA	4mA

Therefore, create a program as shown below, so that the ladder can start to operate with valid conversion data in input words.

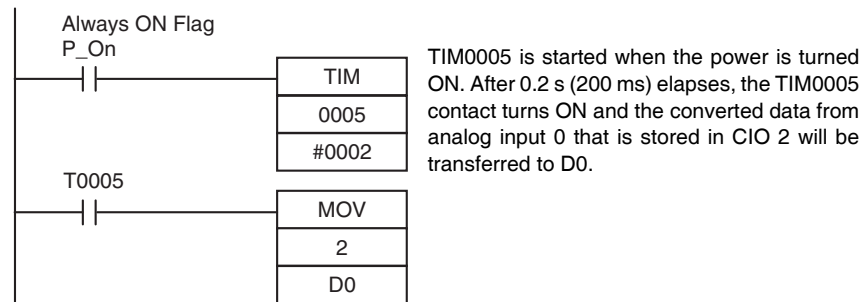

(7) Handling Unit Errors

When an error occurs in the Analog I/O Unit, analog input data will be 0000 and 0 V or 0 mA will be output as the analog output.

If a CPU error or an I/O bus error (fatal errors) occurs at the CPU Unit and the analog output is set to 1 to 5 V or 4 to 20 mA, 0 V or 0 mA will be output. For any other errors at the CPU Unit, 1 V or 4 mA will be output.

(8) Programming Example

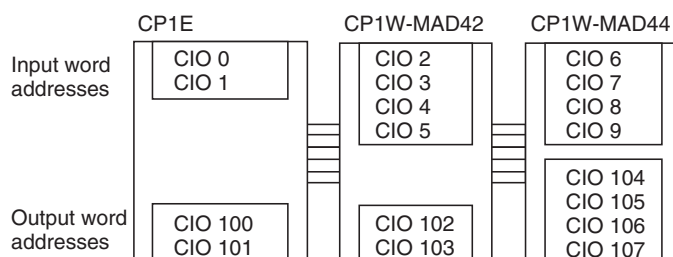

This programming example uses these ranges:

(a) CP1W-MAD42

Analog input	Input range	Range code	Averaging	Set data	Destination word
Input 1	4 to 20 mA	10	Yes	1110 (E hex)	n+1
Input 2	0 to 10 V	01	Yes	1101 (D hex)	n+1
Input 3	0 to 5 V	11	Yes	1111 (F hex)	n+2
Input 4	-10 to 10 V	00	Yes	1100 (C hex)	n+2
Output 1	-10 to 10 V	000	–	1000 (8 hex)	n+1
Output 2	4 to 20 mA	100	–	1100 (C hex)	n+2

(a) CP1W-MAD44

Analog input	Input range	Range code	Averaging	Set data	Destination word
Input 1	4 to 20 mA	10	Yes	1110 (E hex)	n+1
Input 2	0 to 10 V	01	No	1001 (9 hex)	n+1
Input 3	0 to 5 V	11	Yes	1111 (F hex)	n+2
Input 4	-10 to 10 V	00	Yes	1100 (C hex)	n+2
Output 1	-10 to 10 V	000	–	1000 (8 hex)	n+3
Output 2	4 to 20 mA	100	–	1100 (C hex)	n+3
Output 3	0 to 10 V	001	–	1001 (9 hex)	n+4
Output 4	Not use	–	–	0000 (0 hex)	n+4

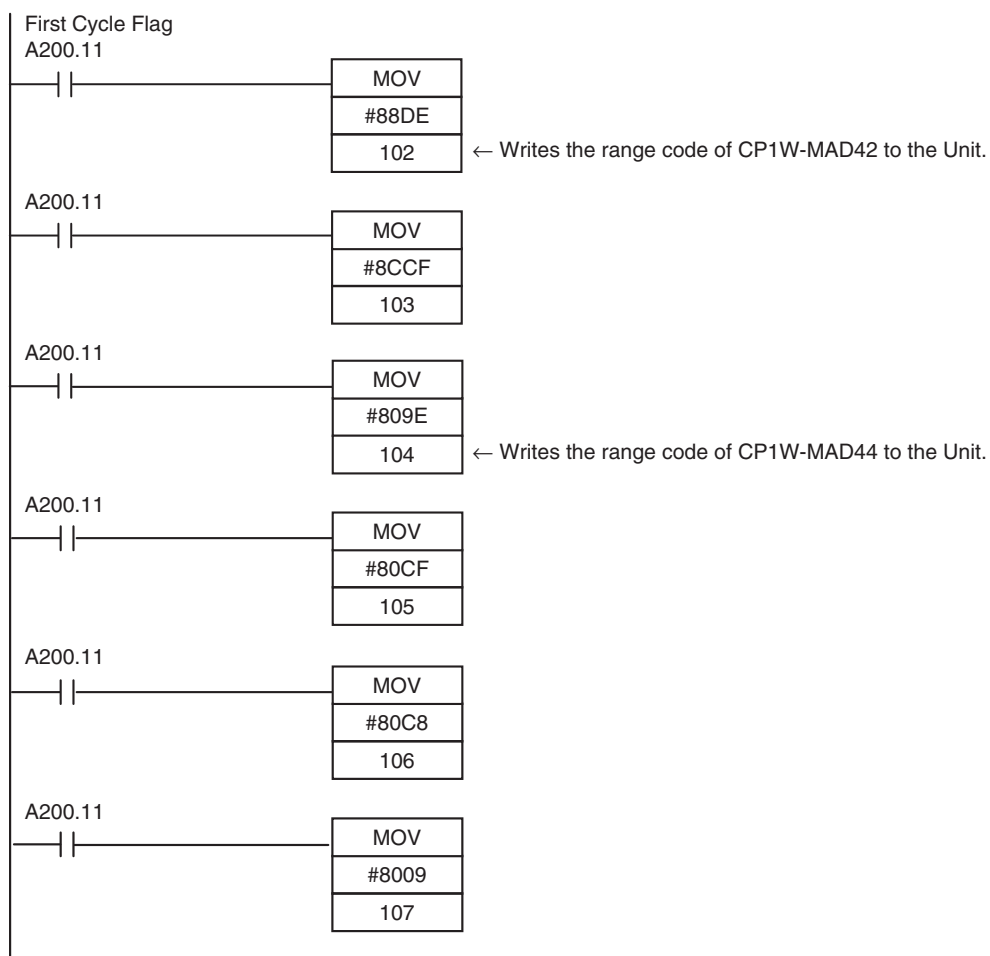

8-4 Temperature Sensor Units

8-4-1 CP1W-TS□1/TS□2 Temperature Sensor Units

Overview

CP1W-TS002/TS102 Temperature Sensor Units each provide up to four input points, and CP1W-TS001/TS101 Temperature Sensor Units each provide up to two input points. The inputs can be from thermocouples or platinum resistance thermometers.

CP1W-TS002/TS102 Temperature Sensor Units are each allocated four input words.

Part Names and Functions

● Temperature Sensor Units: CP1W-TS001/002/101/102

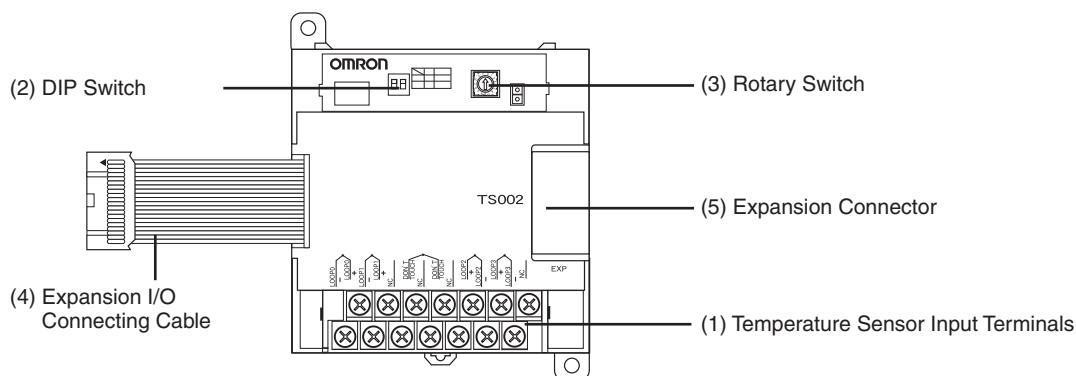

(1) Temperature Sensor Input Terminals

Used to connect temperature sensors such as thermocouples or platinum resistance thermometers.

(2) DIP Switch

Used to set the temperature unit ($^{\circ}\text{C}$ or $^{\circ}\text{F}$) and the number of decimal places used.

(3) Rotary Switch

Used to set the temperature input range. Make the setting according to the specifications of the temperature sensors that are connected.

(4) Expansion I/O Connecting Cable

Connected to the expansion connector of a CP1E CPU Unit or an Expansion Unit or Expansion I/O Unit. The cable is included with the Temperature Sensor Unit and cannot be removed.



Precautions for Safe Use

Do not touch the cables during operation. Static electricity may cause operating errors.

(5) Expansion Connector

Used for connecting Expansion Units or Expansion I/O Units.

Specifications

A CP1W-TS□01/TS□02 Temperature Sensor Unit can be connected to a CP1E CPU Unit.

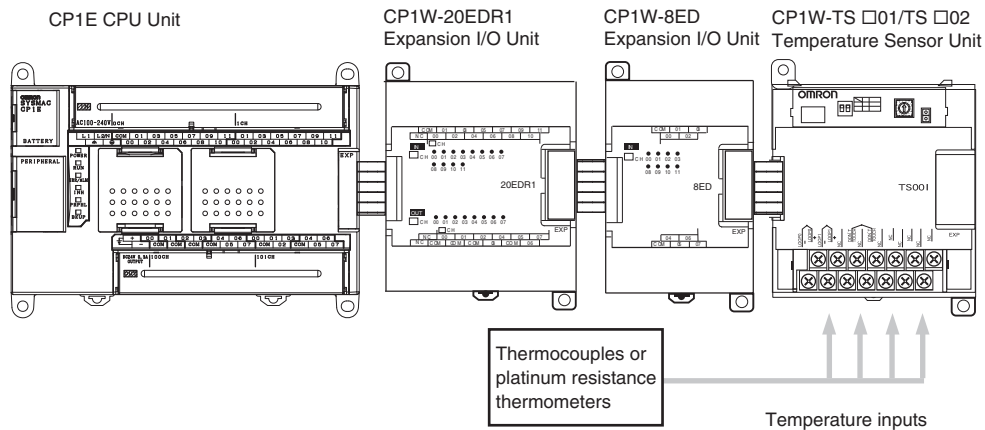

Model	CP1W-TS001	CP1W-TS002	CP1W-TS101	CP1W-TS102
Temperature sensors	Thermocouples		Platinum resistance thermometer	
	Switchable between K and J, but same type must be used for all inputs.		Switchable between Pt100 and JPt100, but same type must be used for all inputs.	
Number of inputs	2	4	2	4
Allocated input words	2	4	2	4
Accuracy	(The larger of $\pm 0.5\%$ of converted value or $\pm 2^\circ\text{C}$) ± 1 digit max. *		(The larger of $\pm 0.5\%$ of converted value or $\pm 1^\circ\text{C}$) ± 1 digit max.	
Conversion time	250 ms for 2 or 4 input points			
Converted temperature data	16-bit binary data (4-digit hexadecimal)			
Isolation	Photocouplers between all temperature input signals			
Current consumption	5 VDC: 40 mA max., 24 VDC: 59 mA max.		5 VDC: 54 mA max., 24 VDC: 73 mA max.	

* Accuracy for a K-type sensor at -100°C or less is $\pm 4^\circ\text{C} \pm 1$ digit max.

Flow of Operation

- 1** Connect the Temperature Sensor Units.
 - Connect the Temperature Sensor Units to the CPU Unit.
- 2** Set the temperature ranges.
 - Set the temperature unit, 2-decimal-place mode if required, and set the temperature input range.
- 3** Connect the temperature sensors.
 - Connect temperature sensors.
- 4** Operation in the ladder program.
 - Read temperature data stored in the input words.

1 Connect the Temperature Sensor Unit to the CPU Unit.

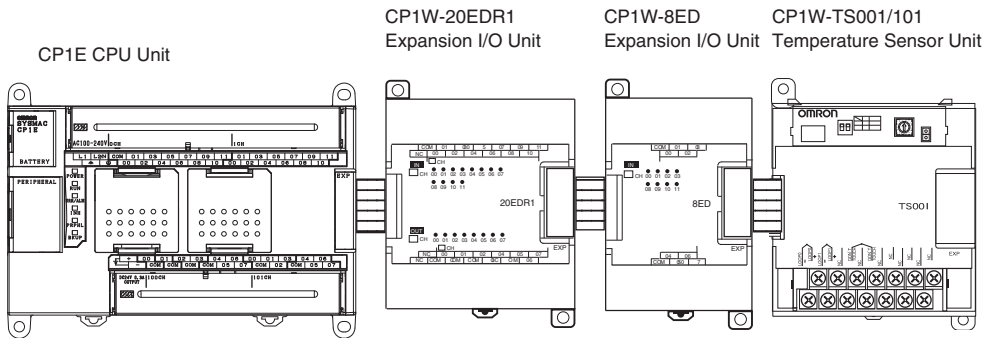

2 Set temperature ranges.

With the Temperature Sensor Unit's DIP switch and rotary switch, set the temperature unit, the number of decimal places, and the temperature input range.



Precautions for Safe Use

Do not touch the DIP switch or rotary switch while power is being supplied. Static electricity may cause operating errors.



Precautions for Correct Use

Always turn OFF the power supply before setting the temperature range.

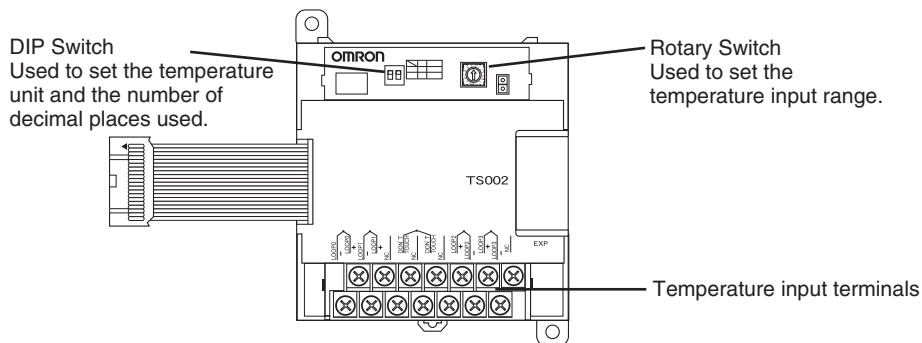

(1) DIP Switch Settings

The DIP switch is used to set the temperature unit (°C or °F) and the number of decimal places.

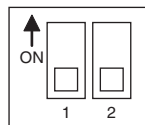

SW	Setting		
1	Temperature unit	OFF	°C
		ON	°F
2	Number of decimal places*	OFF	Normal (0 or 1 digit after the decimal point, depending on the input range)
		ON	2-decimal-place Mode

* For details on 2-decimal-place Mode, refer to *Two-decimal-place Mode* in *Function Descriptions*.

(2) Rotary Switch Setting

Caution

Set the temperature range according to the type of temperature sensor connected to the Unit.
 Temperature data will not be converted correctly if the temperature range does not match the sensor.

Do not set the temperature range to any values other than those for which temperature ranges are given in the following table.
 An incorrect setting may cause operating errors.

The rotary switch is used to set the temperature range.

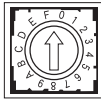

Set-ting	CP1W-TS001/TS002			CP1W-TS101/TS102		
	Input type	Range (°C)	Range (°F)	Input type	Range (°C)	Range (°F)
0	K	-200 to 1,300	-300 to 2,300	Pt100	-200.0 to 650.0	-300.0 to 1,200.0
1		0.0 to 500.0	0.0 to 900.0	JPt100	-200.0 to 650.0	-300.0 to 1,200.0
2	J	-100 to 850	-100 to 1,500	–	Cannot be set.	
3		0.0 to 400.0	0.0 to 750.0	–		
4 to F	–	Cannot be set.		–		

3 Connect Temperature Sensors.

(1) Thermocouples

(a) CP1W-TS001

Either K or J thermocouples can be connected to the CP1W-TS001, but both thermocouples must be the same type and the same input range.

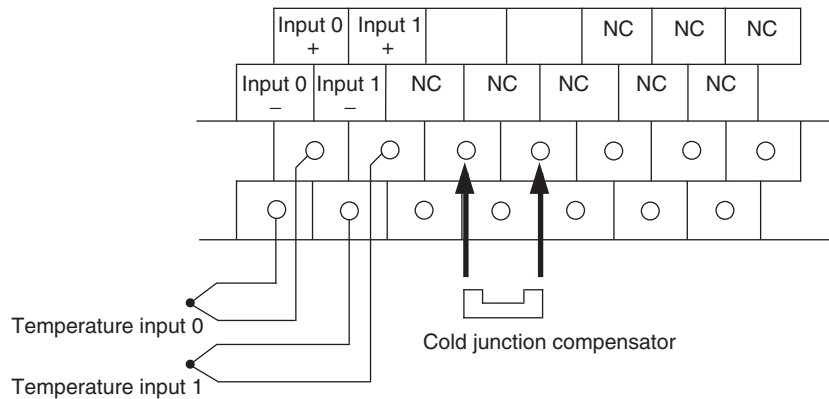

(b) CP1W-TS002

Up to four K or J thermocouples can be connected to the CP1W-TS002, but all four thermocouples must be the same type and the same input range.

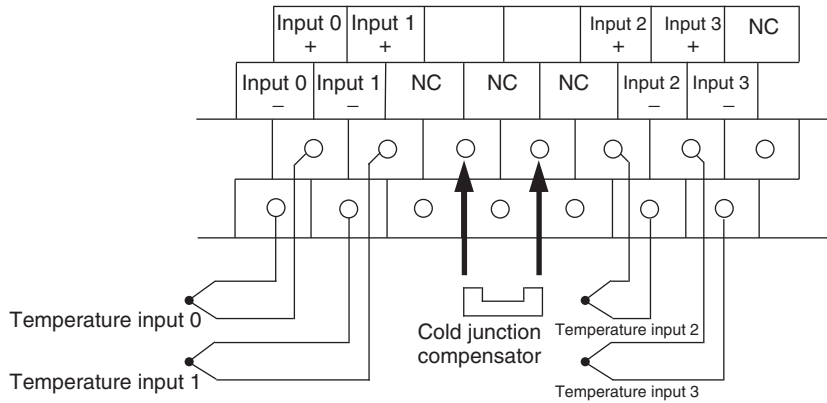

Precautions for Correct Use

When connecting a thermocouple input, observe the following precautions:

- Do not remove the cold junction compensator attached at the time of delivery. If the cold junction compensator is removed, the Unit will not be able to measure temperatures correctly.
- Each of the input circuits is calibrated with the cold junction compensator attached to the Unit. If the Unit is used with the cold junction compensator from other Units, the Unit will not be able to measure temperatures correctly.
- Do not touch the cold junction compensator. Doing so may result in incorrect temperature measurement.

(2) Platinum Resistance Thermometers

(a) CP1W-TS101

One or two Pt or JPt platinum resistance thermometers can be connected to the CP1W-TS101, but both of the thermometers must be of the same type and the same input range must be used for each.

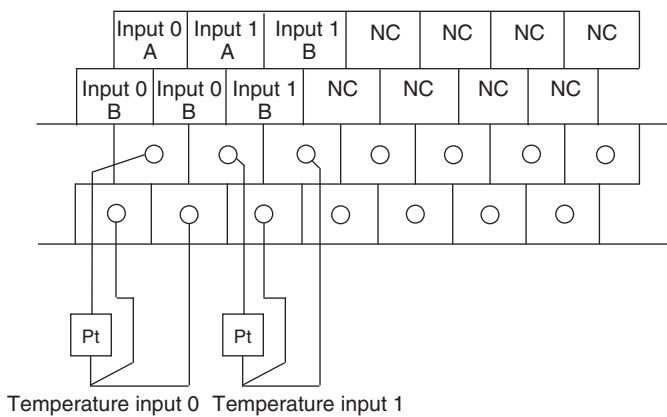

(b) CP1W-TS102

Up to four Pt100 or JPt100 platinum resistance thermometers can be connected to the CP1W-TS102, but all four of the thermometers must be of the same type and the same input range must be used for each.

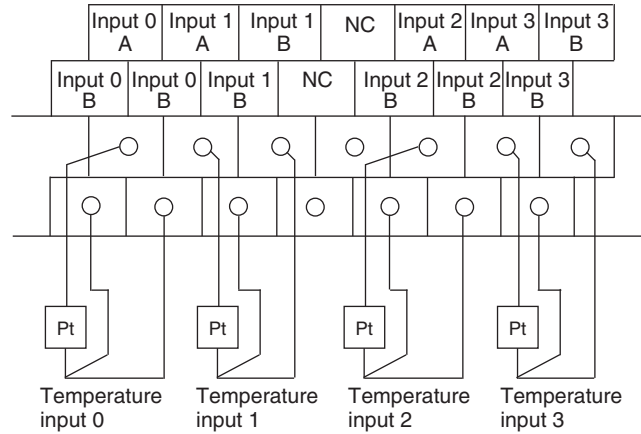

Precautions for Correct Use

Do not connect anything to terminals not used for inputs.

4 Create the ladder program.

(1) Words Allocation

Temperature Sensor Units are allocated words in the same way as other CP-series Expansion Units or Expansion I/O Units, i.e., in order of connection. A Temperature Sensor Unit is allocated the next input words following the input words of the CPU Unit or previous Expansion Unit or Expansion I/O Unit. Two input words are allocated to the 2-input CP1W-TS001 or CP1W-TS101 and four input words are allocated to the 4-input CP1W-TS002 or CP1W-TS102. No output words are allocated.

- Example 1 (E30/40, N30/40/60 or NA20 CPU Unit)

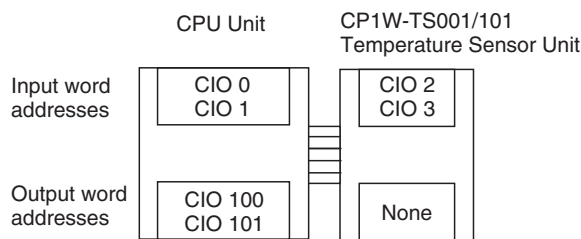

- Example 2 (E30/40, N30/40/60 or NA20 CPU Unit)

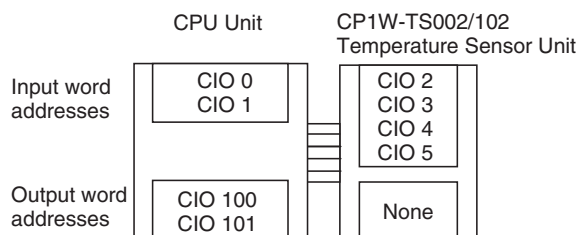

(2) Reading Temperature Data

The temperature data will be stored in the input words allocated to the Temperature Sensor Unit in 4-digit hexadecimal.

CP1W-TS002/TS102

m+1	Converted temperature data from input 0
m+2	Converted temperature data from input 1
m+3	Converted temperature data from input 2
m+4	Converted temperature data from input 3

CP1W-TS001/TS101

m+1	Converted temperature data from input 0
m+2	Converted temperature data from input 1

“m” is the last input word allocated to the CPU Unit, Expansion I/O Unit, or Expansion Unit connected immediately before the Temperature Sensor Unit.

- If the converted value is a negative value, it will be stored as its two's complements.
- Data for range codes that include one digit after the decimal point are stored as binary without the decimal point, i.e., 10 times the actual value is stored.

Input		Data conversion examples
Unit: 1°C	K, J	850°C→0352 hex -200°C→FF38 hex
Unit: 0.1°C	Pt, JPt, K, J	×10 500.0°C→5000→1388 hex -20.0°C→-200→FF38 hex -200.0°C→-2000→F830 hex

- If the input temperature exceeds the maximum or minimum value in the temperature input range that has been set by $\pm 20^{\circ}\text{C}$ or $\pm 20^{\circ}\text{F}$, the displayed value will be held.
- If the circuit is disconnected, the open-circuit detection function will operate and the converted temperature data will be set to 7FFF.
- The open-circuit detection function will be automatically cleared and normal input temperature conversion will begin automatically when the input temperature returns to the convertible range.

(3) Startup Operation

After power is turned ON, approximately 1 s is required for the first conversion data to be stored in the input word. During that period, the data will be 7FFE. Therefore, create a program as shown below, so that when operation begins simultaneously with startup it will wait for valid conversion data.

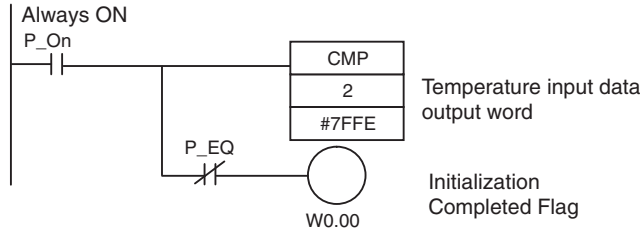

(4) Handling Unit Errors

- Expansion Unit and Expansion I/O Unit errors are output to bits 0 to 5 of word A436. The bits are allocated from A436.00 in order starting from the Unit nearest the CPU Unit. CP1W-TS002 and CP1W-TS102 Temperature Sensor Units are allocated two bits each. Use these flags in the program when it is necessary to detect Expansion Unit/Expansion I/O Unit errors.
- When an error occurs, the Temperature Sensor Unit data becomes 7FFF hex (the same as for an open-circuit detection). With an open-circuit detection, it is not reflected in word A436.

(5) Programming Example (E30/40, N30/40/60 or NA20 CPU Unit)

(a) The following programming example shows how to convert the input data from 2 temperature sensor inputs to BCD and store the result in D0 and D1.

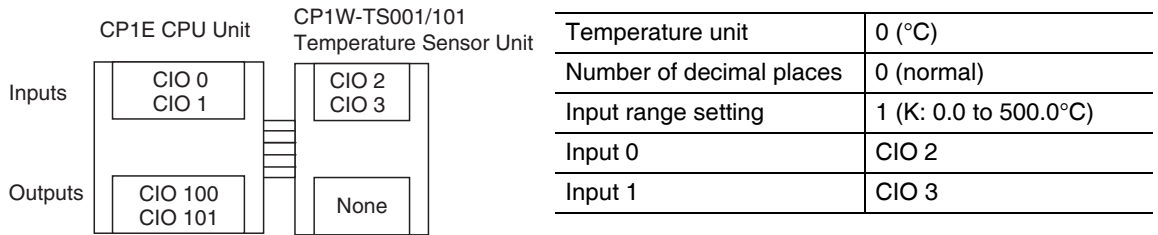

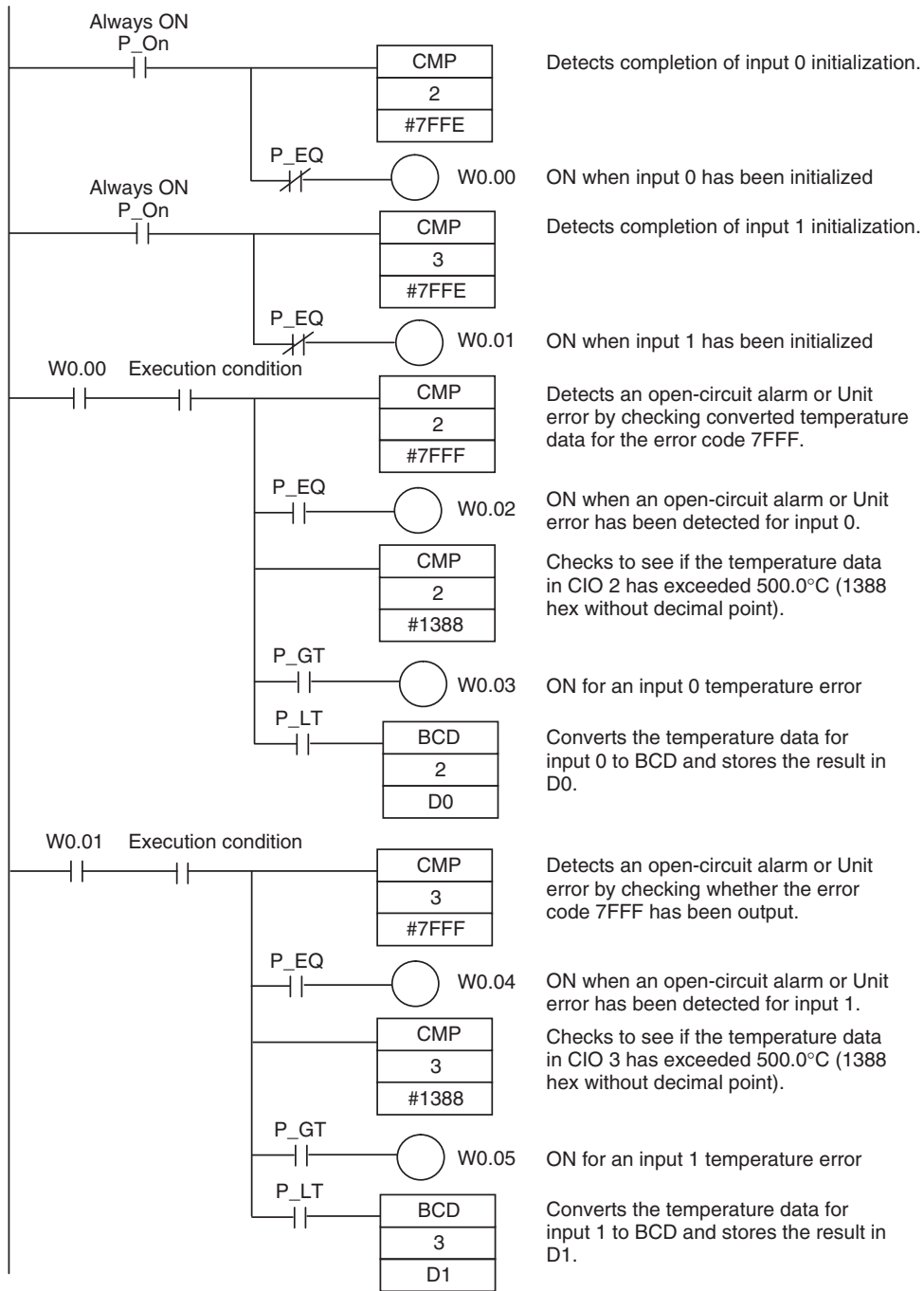

(7) Programming with SCL2 Instruction

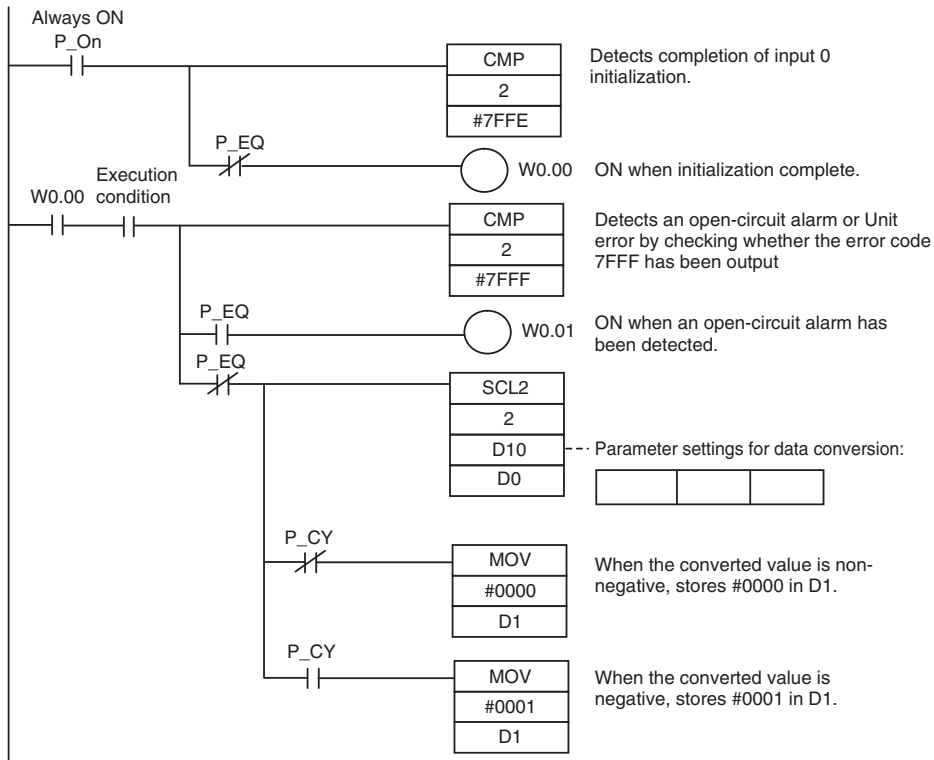

• Operation

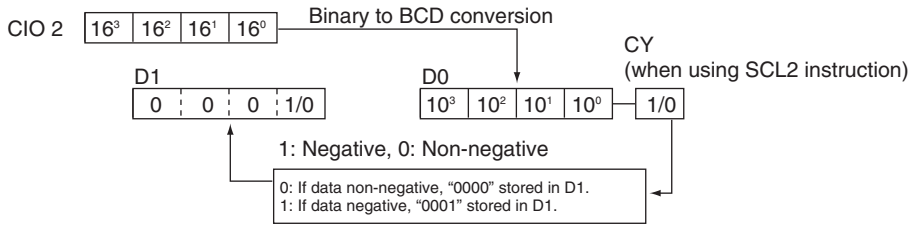

Function Descriptions

● Two-decimal-place Mode

If pin 2 on the DIP switch is turned ON, values are stored to two decimal places. In this case, temperature data is stored as 6-digit signed hexadecimal (binary) data with 4 digits in the integer portion and 2 digits after the decimal point. The actual data stored in memory is 100 times the actual value, i.e., the decimal point is not indicated. Methods for handling this data are described in this section.



Additional Information

When set to store values to two decimal places, temperature data as far as two digits after the decimal point is converted to 6-digit binary data, but the actual resolution is not 0.01°C (°F). For this reason, there may be skipping and inaccuracies in the first digit after the decimal point 0.1°C (°F). Treat any resolution above that specified for the normal data format as reference data.

Temperature Data Partitioning and Structure

Temperature Data (Actual Temperature x 100 Binary)

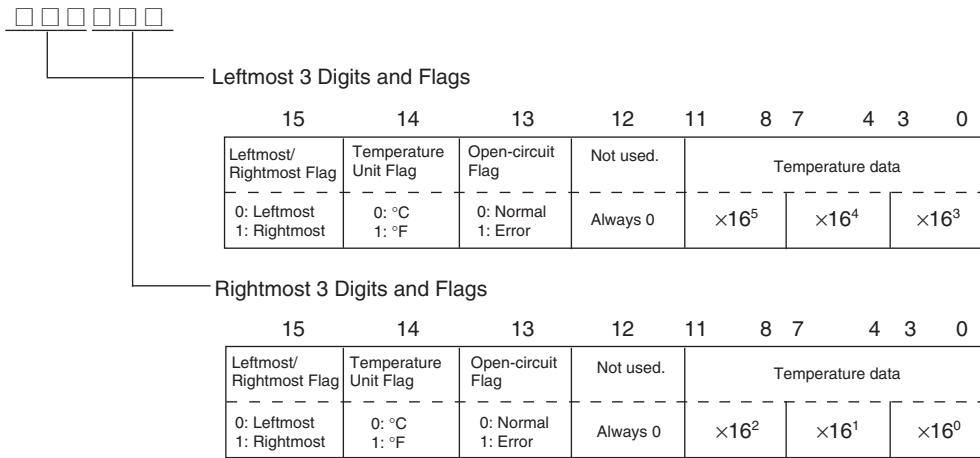

Leftmost/Rightmost Flag: Indicates whether the leftmost or rightmost 3 digits are provided.
 Temperature Unit Flag: Indicates whether the temperature is in °C or °F.
 Open-circuit Flag: Turns ON (1) when an open-circuit is detected. The temperature data will be 7FF FFF if this flag is ON.

Data Conversion Examples

Example 1

Temperature: 1,130.25°C

×100: 113025

Temperature Data: 01B981 (hexadecimal for 113025)

Leftmost 3 Digits and Flags

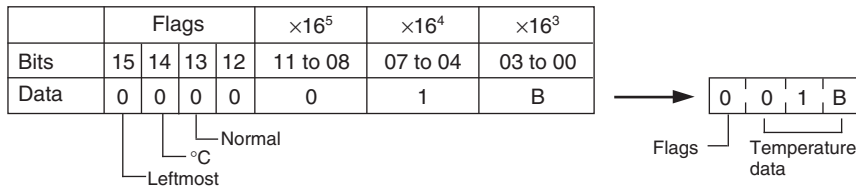

Rightmost 3 Digits and Flags

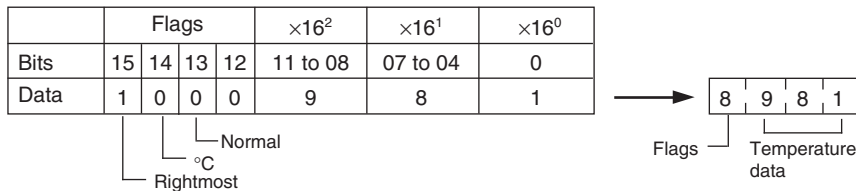

Example 2

Temperature: -100.12°C

×100: -10012

Temperature Data: FFD8E4 (hexadecimal for -10012)

Leftmost 3 Digits and Flags

	Flags				×16 ⁵	×16 ⁴	×16 ³
Bits	15	14	13	12	11 to 08	07 to 04	03 to 00
Data	0	0	0	0	F	F	D

Normal
 °C
 Leftmost

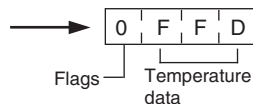

Rightmost 3 Digits and Flags

	Flags				×16 ²	×16 ¹	×16 ⁰
Bits	15	14	13	12	11 to 08	07 to 04	03 to 00
Data	1	0	0	0	8	E	4

Normal
 °C
 Rightmost

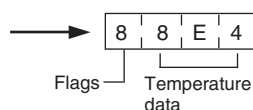

Example 3

Temperature: -200.12°F

×100: -20012

Temperature Data: FFB1D4 (hexadecimal for -20012)

Leftmost 3 Digits and Flags

	Flags				×16 ⁵	×16 ⁴	×16 ³
Bits	15	14	13	12	11 to 08	07 to 04	03 to 00
Data	0	1	0	0	F	F	B

Normal
 °F
 Leftmost

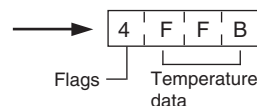

Rightmost 3 Digits and Flags

	Flags				×16 ²	×16 ¹	×16 ⁰
Bits	15	14	13	12	11 to 08	07 to 04	03 to 00
Data	1	1	0	0	1	D	4

Normal
 °F
 Rightmost

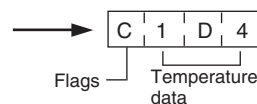

Example 4

Temperature: Open circuit (°F)

Temperature Data: 7FFFFFFF

Leftmost 3 Digits and Flags

	Flags				×16 ⁵	×16 ⁴	×16 ³
Bits	15	14	13	12	11 to 08	07 to 04	03 to 00
Data	0	1	1	0	7	F	F

Error
 °F
 Leftmost

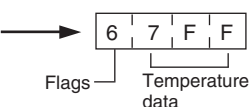

Rightmost 3 Digits and Flags

	Flags				×16 ²	×16 ¹	×16 ⁰
Bits	15	14	13	12	11 to 08	07 to 04	03 to 00
Data	1	1	1	0	F	F	F

Error
 °F
 Rightmost

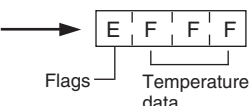



Additional Information

- Leftmost digits are stored in the lower memory addresses. Treat the data in the lower memory address as the leftmost digits when programming.
- Be sure that the data is read at least once every 125 ms to allow for the CPU Unit's cycle time and communications time. Correct data may not be obtained if the read cycle is greater than 125 ms.

Programming Example

The following programming example shows how to use 2-decimal-place Mode for the following PLC configuration.

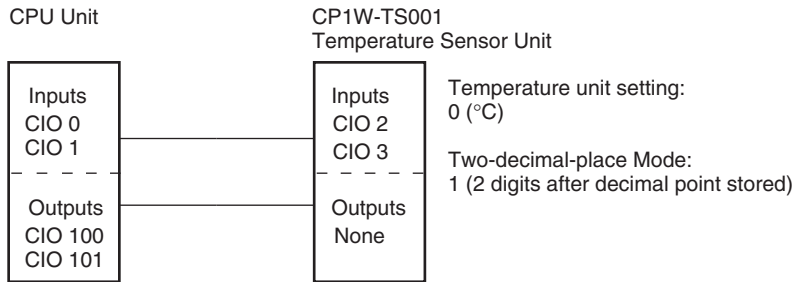

In this example, 100 times the temperature data for temperature input 0 (input to CIO 002) is stored in binary form in D100 to D102.

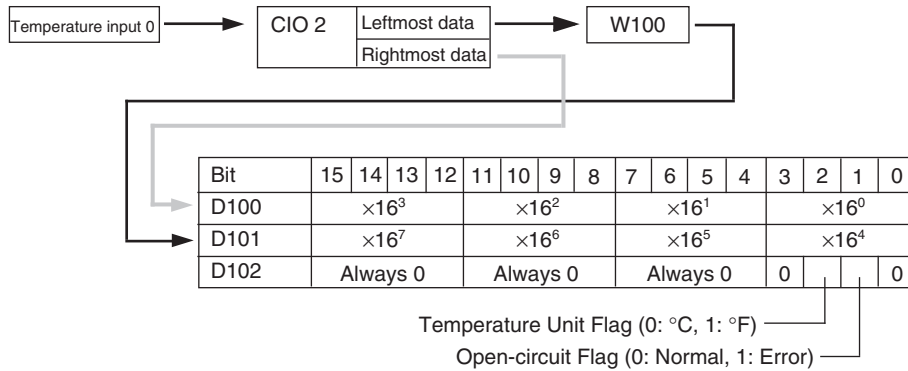

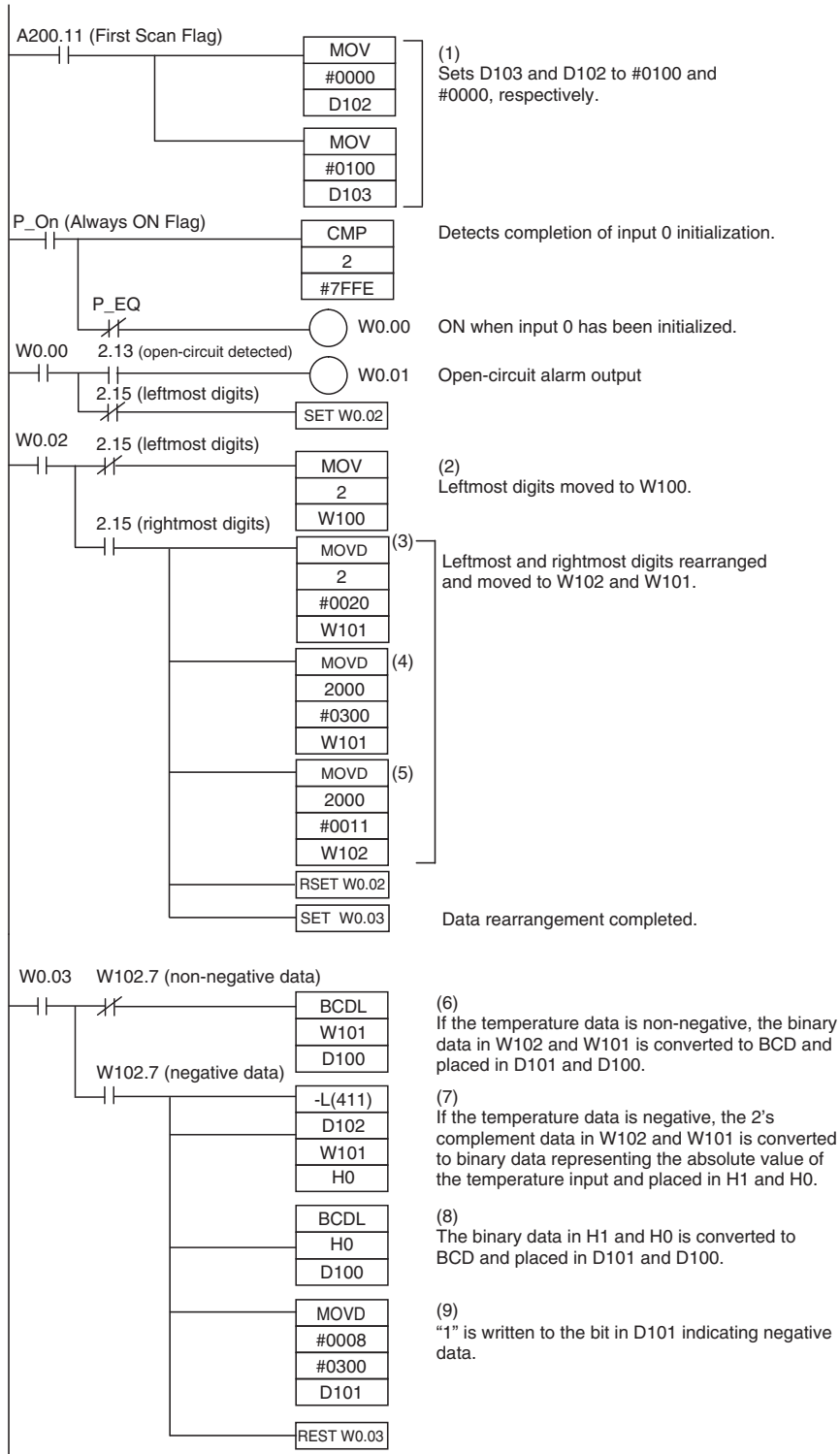

Description of Operation

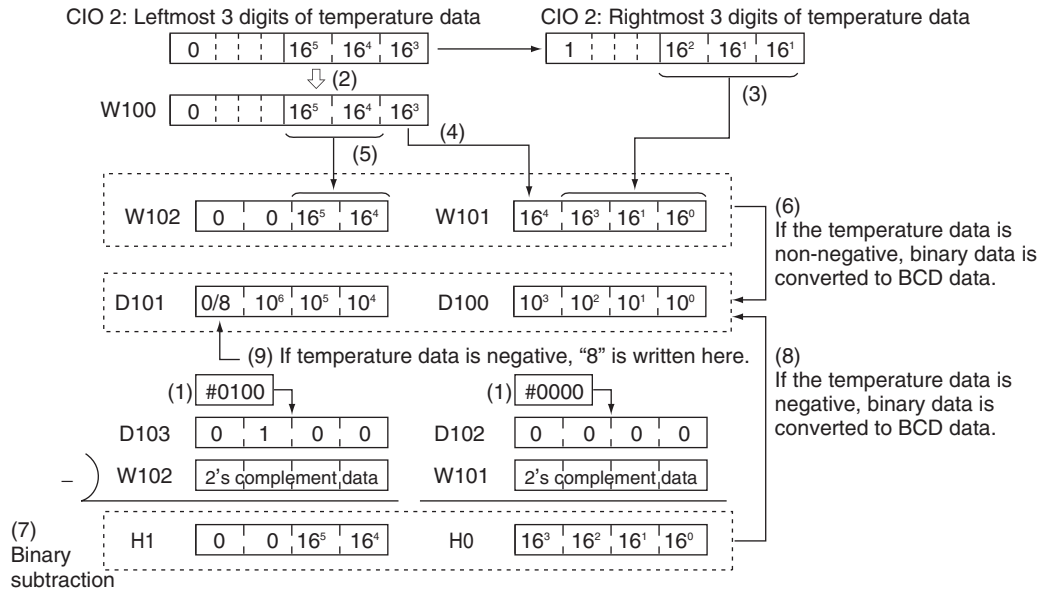

8-4-2 CP1W-TS003 Temperature Sensor Units

Overview

CP1W-TS003 Temperature Sensor Unit provides up to four input points. The inputs can be from thermocouples or analog inputs.

CP1W-TS003 Temperature Sensor Unit is allocated four input words, so no more than three Units can be connected.

Part Names and Functions

● Temperature Sensor Units: CP1W-TS003

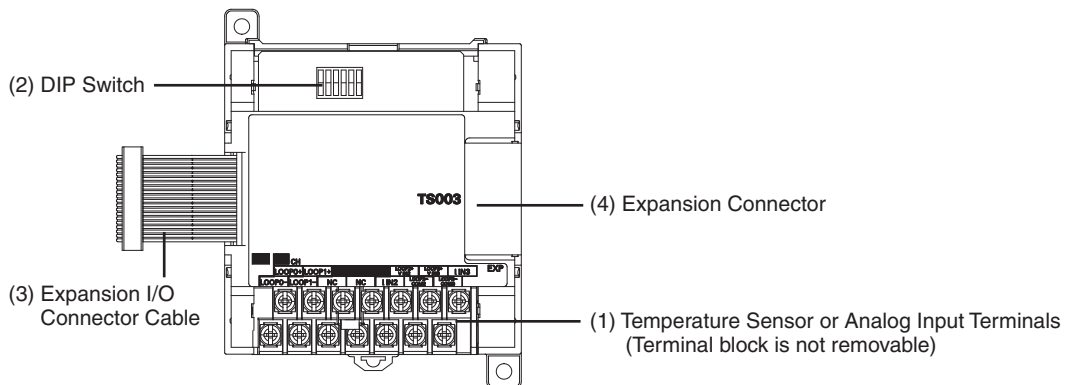

(1) Temperature Sensor Input Terminals

Used to connect temperature sensors such as thermocouples or analog inputs.

(2) DIP Switch

Used to set the input type (temperature or analog input), the input thermocouple type (K or J) and the temperature unit (°C or °F). Make the setting according to the specifications of the temperature sensors or analog inputs that are connected.

(3)Expansion I/O Connecting Cable

Connected to the expansion connector of a CP1E CPU Unit or an Expansion Unit or Expansion I/O Unit. The cable is included with the Temperature Sensor Unit and cannot be removed.

**Precautions for Safe Use**

Do not touch the cables during operation. Static electricity may cause operating errors.

(4)Expansion Connector

Used for connecting Expansion Units or Expansion I/O Units.

Specifications

Item	CP1W-TS003	
Temperature sensors	Thermocouples or analog input *1 Switchable between K and J, but same type must be used for all inputs.	
Number of inputs	4	
Allocated input words	4	
Max. number of Units	3	
Accuracy at 25°C	Thermocouple inputs	(The larger of +/-0.5% of converted value or ±2°C) ±1 digit max. *2
	Analog voltage inputs	0.5% full scale
	Analog current inputs	0.6% full scale
Accuracy at 0 to 55 °C	Thermocouple inputs	(The larger of ±1% of converted value or ±4°C) ±1 digit max. *3
	Analog voltage inputs	1.0% full scale
	Analog current inputs	1.2% full scale
Input signal range	Thermocouple inputs	K: -200.0 to 1300.0°C or -300.0 to 2300.0°F J: -100.0 to 850.0°C or -100.0 to 1500.0°F
	Analog voltage inputs	0 to 10V, 1 to 5V
	Analog current inputs	4 to 20mA
Resolution	Thermocouple inputs	0.1°C or 0.1°F
	Analog inputs	1/12000 (full scale)
Max. rated input	Analog voltage inputs	±15V
	Analog current inputs	±30mA
External input impedance	Analog voltage inputs	1MΩ min.
	Analog current inputs	250 Ω
Open-circuit detection function	Supported	
Averaging function	Unsupported	
Conversion time	250 ms for 4 input points	
Converted temperature data	16-bit binary data (4-digit hexadecimal) 2-decimal-place mode is not supported	
Converted AD data	16-bit binary data (4-digit hexadecimal)	
Isolation	Photocouplers between any two input signals	
Current consumption	5 VDC: 70 mA max., 24 VDC: 30 mA max.	

*1 Only last two channels can be used as analog input.

*2 Accuracy for a K-type sensor at -100°C or less is ±4°C ±1 digit max.

*3 Accuracy for a K-type sensor at -100°C or less is ±10°C ±1 digit max.

● Analog Input Signal Ranges

Analog input data is digitally converted according to the input signal range as shown below.



Additional Information

When the input exceeds the specified range, the A/D conversion data will be fixed at either the lower limit or upper limit.

0 to 10 V

The 0 to 10 V range corresponds to the hexadecimal values 0000 to 2EE0 (0 to 12000). The entire data range is FDA8 to 3138 (-600 to 12600). A negative voltage is expressed as a two's complement.

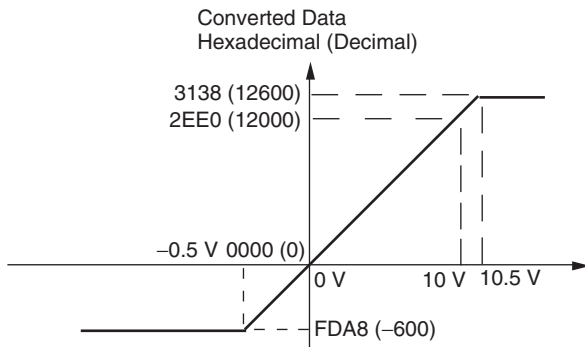

1 to 5 V

The 1 to 5 V range corresponds to the hexadecimal values 0000 to 2EE0 (0 to 12000). The entire data range is FDA8 to 3138 (-600 to 12600). Inputs between 0.8 and 1 V are expressed as two's complements. If the input falls below 0.8 V, open-circuit detection will activate and converted data will be 8000.

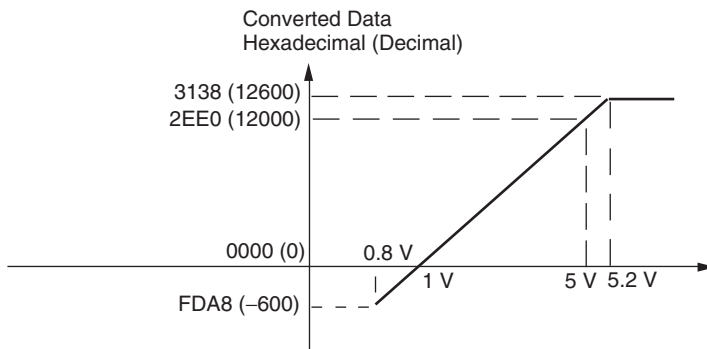

4 to 20 mA

The 4 to 20 mA range corresponds to the hexadecimal values 0000 to 2EE0 (0 to 12000). The entire data range is FDA8 to 3138 (-600 to 12600). Inputs between 3.2 and 4 mA are expressed as two's complements. If the input falls below 3.2 mA, open-circuit detection will activate and converted data will be 8000.

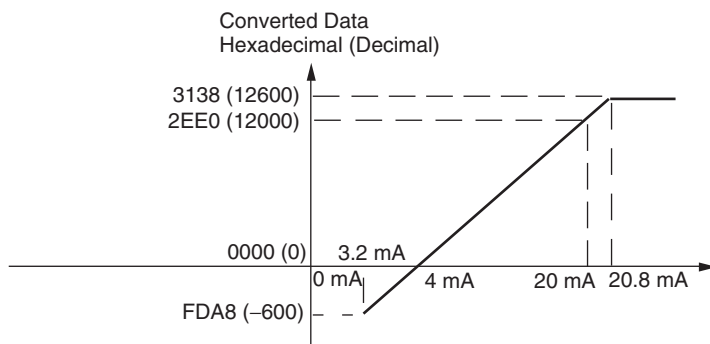

● Open-circuit Detection Function for Temperature

If the circuit is disconnected, the open-circuit detection function will operate and the converted temperature data will be set to 7FFF.

● Open-circuit Detection Function for Analog Inputs

The open-circuit detection function is activated when the input range is set to 1 to 5 V and the voltage drops below 0.8 V, or when the input range is set to 4 to 20 mA and the current drops below 3.2 mA. When the open-circuit detection function is activated, the converted data will be set to 8,000.

The time for enabling or clearing the open-circuit detection function is the same as the time for converting the data. If the input returns to the convertible range, the open-circuit detection is cleared automatically and the output returns to the normal range.

Flow of Operation

- 1** Connect the Temperature Sensor Units.
 - Connect the Temperature Sensor Units to the CPU Unit.
- 2** Set the temperature or analog ranges.
 - Set the input type (temperature or analog input), the input thermocouple type (K or J) and the temperature unit (°C or °F).
- 3** Connect the temperature sensors or analog devices.
 - Connect temperature sensors or analog devices.
- 4** Operation in the ladder program.
 - Read converted data stored in the input words.

1 Connect the Temperature Sensor Unit to the CPU Unit.

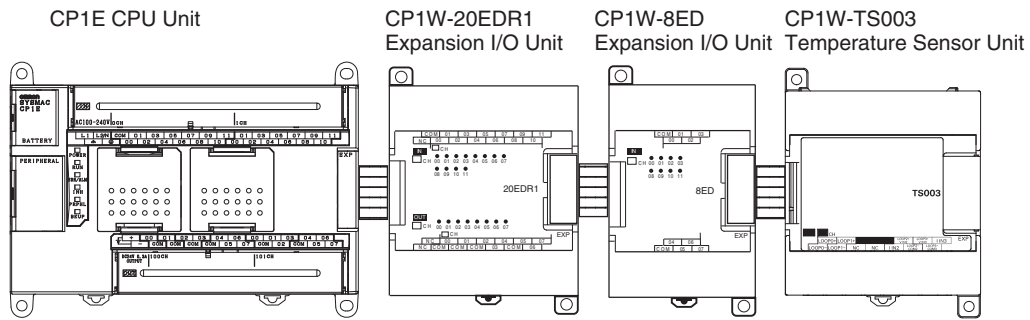

2 Set temperature or analog ranges.



Precautions for Safe Use

Do not touch the DIP switch while power is being supplied. Static electricity may cause operating errors.



Precautions for Correct Use

Always turn OFF the power supply before setting the temperature range.

⚠ Caution

Set the temperature range according to the type of temperature sensor connected to the Unit.

Temperature data will not be converted correctly if the temperature range does not match the sensor.



Do not set the temperature range to any values other than those for which temperature ranges are given in the following table.

An incorrect setting may cause operating errors.



With the Temperature Sensor Unit's DIP switch, set the input type (temperature or analog input), the input thermocouple type (K or J) and the temperature unit (°C or °F).

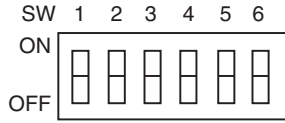

SW	Setting		
1	Thermocouple type of temperature sensor	ON	J
		OFF	K
2	Temperature unit	ON	°F
		OFF	°C
3	NC		
4	Input type selection for the third input (Input 2)	ON	Analog input
		OFF	Thermocouple
5	Input type selection for the fourth input (Input 3)	ON	Analog input
		OFF	Thermocouple
6	Analog input signal range	ON	1 to 5V/4 to 20mA
		OFF	0 to 10V

Temperature input			Analog input	
Input type	Range (°C)	Range (°F)	Input type	Range
K	-200.0 to 1300.0	-300.0 to 2300.0	Voltage	0 to 10V/1 to 5V
J	-100.0 to 850.0	-100.0 to 1500.0	Current	4 to 20mA



Additional Information

Fahrenheit temperature uses the following equation to convert the temperature unit from Celsius, but the temperature input range is different between Fahrenheit and Celsius.
 Fahrenheit temperature (°F) = Celsius temperature (°C) x 1.8 + 32

3 Connect Temperature Sensors.

(1) Thermocouples

Either K or J thermocouples can be connected, but all four thermocouples must be the same type and the same input range. Only last two channels can be used as analog inputs.

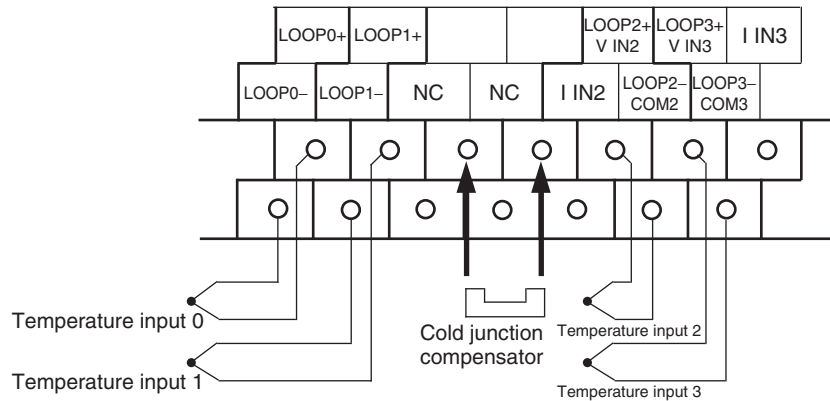



Precautions for Correct Use

When connecting a thermocouple input, observe the following precautions:

- Do not remove the cold junction compensator attached at the time of delivery. If the cold junction compensator is removed, the Unit will not be able to measure temperatures correctly.
- Each of the input circuits is calibrated with the cold junction compensator attached to the Unit. If the Unit is used with the cold junction compensator from other Units, the Unit will not be able to measure temperatures correctly.
- Do not touch the cold junction compensator. Doing so may result in incorrect temperature measurement.

(2) Analog Inputs

Last two channels can be used as analog inputs, but two of the analog inputs must be the same range.

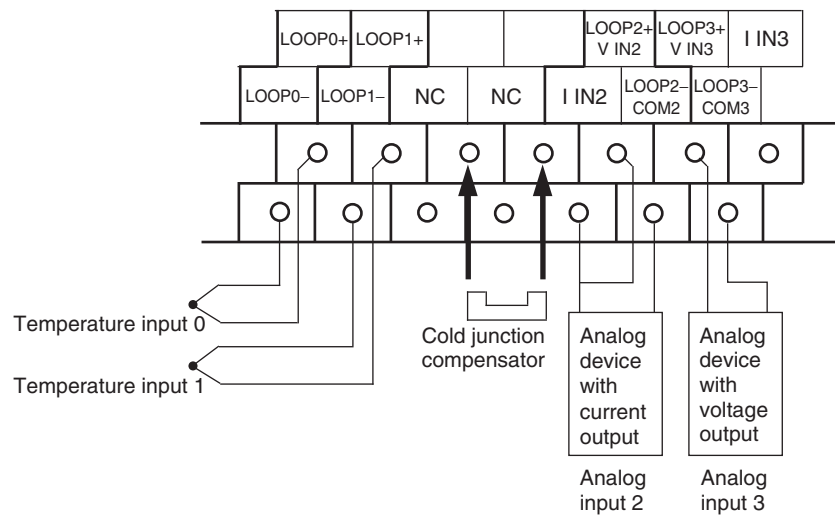

- Wiring for Analog Inputs

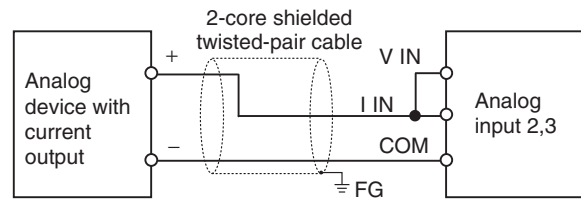
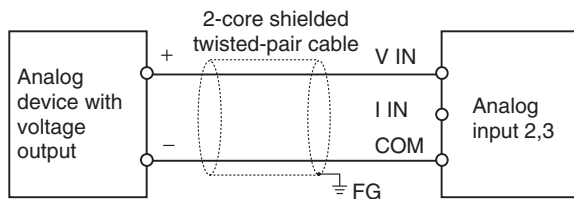

Precautions for Correct Use

- When an input is not being used, short the + and – terminals.
- Separate wiring from power lines (AC power supply lines, high-voltage lines, etc.)
- When there is noise in the power supply line, install a noise filter on the input section and the power supply.

4 Create the ladder program.

(1) Word Allocations

Temperature Sensor Units are allocated words in the same way as other CP-series Expansion Units or Expansion I/O Units, in order of connection. A Temperature Sensor Unit is allocated the next input words following the input words of the CPU Unit or previous Expansion Unit or Expansion I/O Unit. Four input words are allocated to CP1W-TS003.

- Example

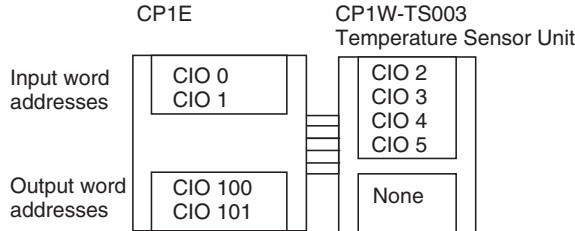

(2) Reading Temperature or Analog Data

The temperature or analog data will be stored in the input words allocated to the Temperature Sensor Unit in 4-digit hexadecimal.

Reading Temperature Data

m+1	Converted temperature data from input 0
m+2	Converted temperature data from input 1
m+3	Converted temperature data from input 2
m+4	Converted temperature data from input 3

Reading Analog Data

m+3	Converted analog data from input 2
m+4	Converted analog data from input 3

“m” is the last input word allocated to the CPU Unit, Expansion I/O Unit, or Expansion Unit connected immediately before the Temperature Sensor Unit.

- Negative values are stored as 2’s complements.
- Data for range codes that include one digit after the decimal point are stored without the decimal point, i.e., 10 times the actual value is stored.

Input		Data conversion examples	
Unit: 0.1°C	K or J	×10	500.0°C → 5000 → 1388 hex -20.0°C → -200 → FF38 hex -200.0°C → -2000 → F830 hex

- If the input temperature exceeds the maximum or minimum value in the temperature input range that has been set by $\pm 20^{\circ}\text{C}$ or $\pm 20^{\circ}\text{F}$, the displayed value will be held.
- If the circuit is disconnected, the open-circuit detection function will operate and the converted temperature data will be set to 7FFF.
- The open-circuit detection function will be automatically cleared and normal input temperature conversion will begin automatically when the input temperature returns to the convertible range.

(3) Startup Operation

After power is turned ON, approximately 1 s is required for the first conversion data to be stored in the input word. During that period, the data will be 7FFE. Therefore, create a program as shown below, so that the ladder can start to operate with valid conversion data in input words.

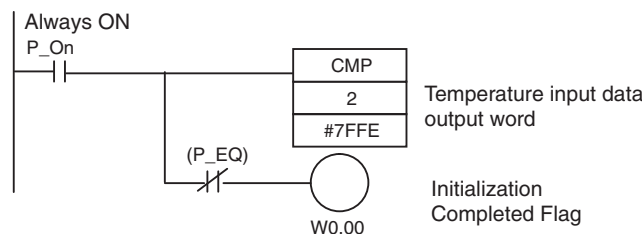

(4) Programming Example

The following programming example shows how to store the input data of CP1W-TS003 (4 inputs) in D0 to D3, and W10.00 to W10.03 turn ON at the time of open-circuit detection.

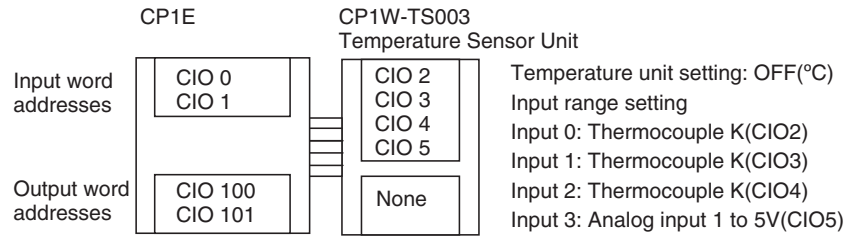

• DIP Switch Setting

SW1	OFF	K
SW2	OFF	°C
SW3	NC	
SW4	OFF	Thermocouple
SW5	ON	Analog
SW6	ON	1 to 5V/4 to 20mA

• Wiring Diagram

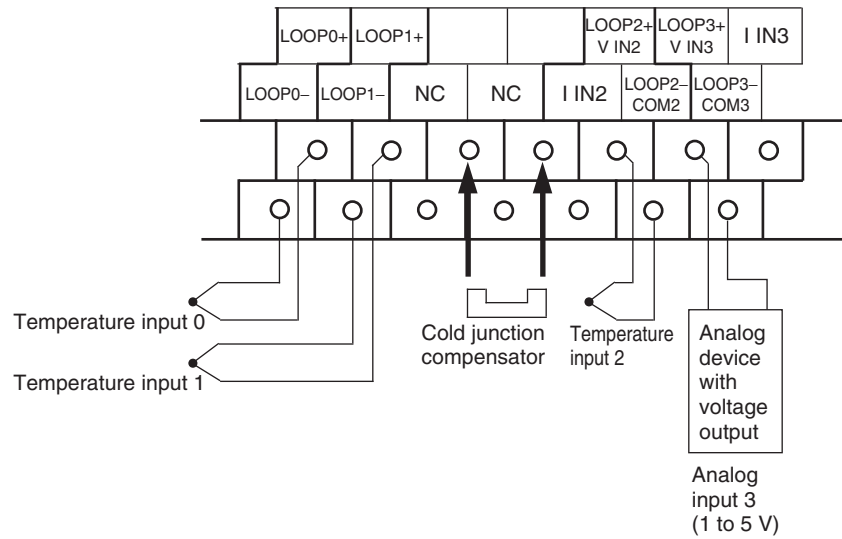

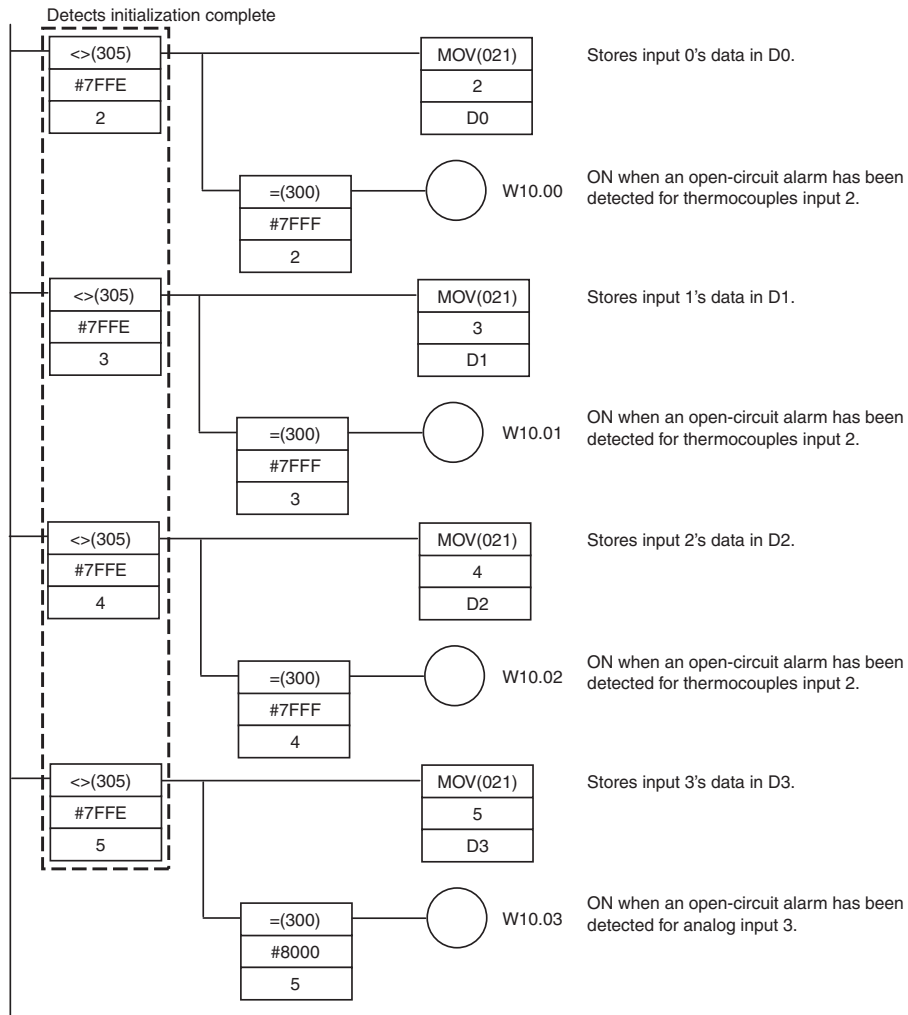

8-4-3 TS004 Temperature Sensor Units

Overview

CP1W-TS004 Temperature Sensor Unit provide up to twelve input points. The inputs can be from thermocouples.

CP1W-TS004 Temperature Sensor Unit is allocated two input words and one output word, so no more than seven Units can be connected.

Part Names and Functions

● Temperature Sensor Units: CP1W-TS004

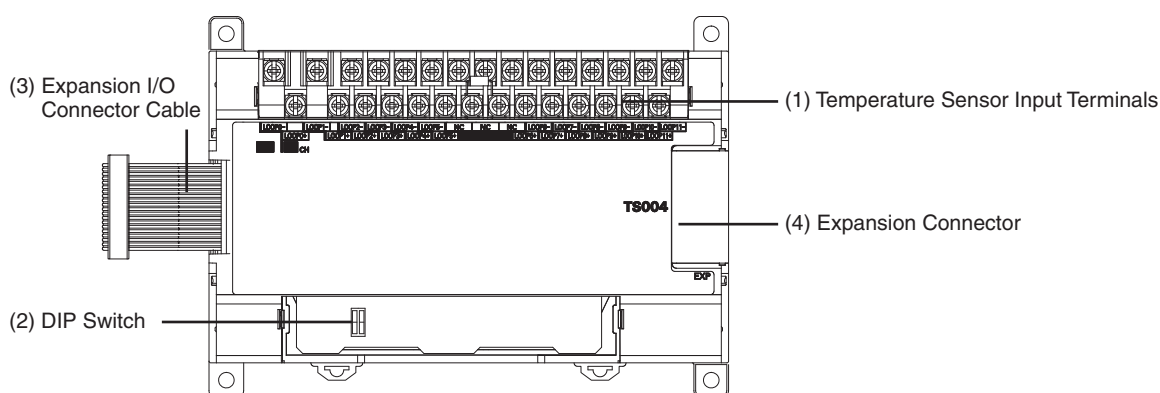

(1) Temperature Sensor Input Terminals

Used to connect temperature sensors such as thermocouples.

(2) DIP Switch

Used to set the temperature unit ($^{\circ}\text{C}$ or $^{\circ}\text{F}$) and the temperature input range. Make the setting according to the specifications of the temperature sensors that are connected.

(3) Expansion I/O Connecting Cable

Connected to the expansion connector of a CP1E CPU Unit or an Expansion Unit or Expansion I/O Unit. The cable is included with the Temperature Sensor Unit and cannot be removed.



Precautions for Safe Use

Do not touch the cables during operation. Static electricity may cause operating errors.

(4) Expansion Connector

Used for connecting Expansion Units or Expansion I/O Units.

Specifications

Item		CP1W-TS004
Temperature sensors		Thermocouples
		Switchable between K and J, but same type must be used for all inputs.
Number of inputs		12
Allocated input words		2
Allocated output words		1
Accuracy	25°C	(The larger of $\pm 0.5\%$ of converted value or $\pm 2^\circ\text{C}$) ± 1 digit max. *1
	0 to 55°C	(The larger of $\pm 1\%$ of converted value or $\pm 4^\circ\text{C}$) ± 1 digit max. *2
Conversion time		500 ms for 12 input points
Converted temperature data		16-bit binary data (4-digit hexadecimal) 2-decimal-place mode is not supported
Isolation		Photocouplers between any two input signals
Current consumption		5 VDC: 80 mA max., 24 VDC: 50 mA max.

*1 Accuracy for a K-type sensor at -100°C or less is $\pm 4^\circ\text{C} \pm 1$ digit max.

*2 Accuracy for a K-type sensor at -100°C or less is $\pm 10^\circ\text{C} \pm 1$ digit max.

● Open-circuit Detection Function for Temperature

If the circuit is disconnected, the open-circuit detection function will operate and the converted temperature data will be set to 7FFF.

Flow of Operation

- 1 **Connect the Temperature Sensor Units.**
 - Connect the Temperature Sensor Units to the CPU Unit.
- 2 **Set the temperature ranges.**
 - Set the temperature unit and set the temperature input range.
- 3 **Connect the temperature sensors.**
 - Connect temperature sensors.
- 4 **Operation in the ladder program.**
 - Read converted data stored in the input words.

- 1 **Connect the Temperature Sensor Unit to the CPU Unit.**

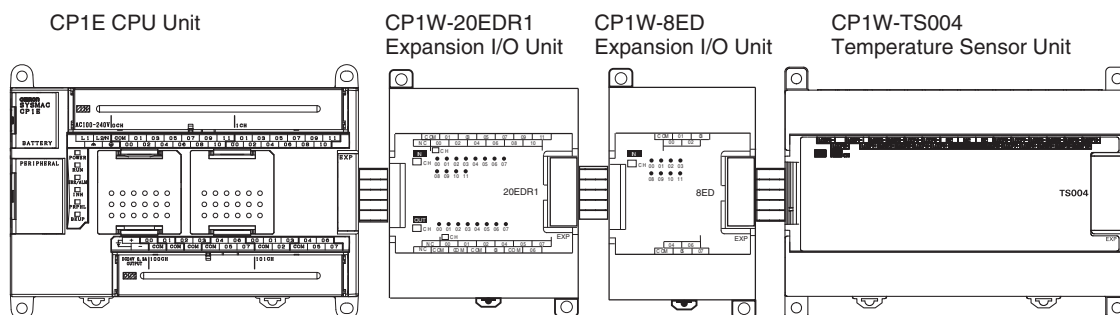

2 Set temperature ranges.



Precautions for Safe Use

Do not touch the DIP switch while power is being supplied. Static electricity may cause operating errors.



Precautions for Correct Use

Always turn OFF the power supply before setting the temperature range.

! Caution

Set the temperature range according to the type of temperature sensor connected to the Unit.

Temperature data will not be converted correctly if the temperature range does not match the sensor.



Do not set the temperature range to any values other than those for which temperature ranges are given in the following table.

An incorrect setting may cause operating errors.



With the Temperature Sensor Unit's DIP switch, set the temperature unit and the temperature input range.

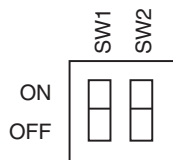

SW	Setting		
1	Input type	ON	J
		OFF	K
2	Temperature unit	ON	°F
		OFF	°C

Temperature input		
Input type	Range (°C)	Range (°F)
K	-200.0 to 1300.0	-300.0 to 2300.0
J	-100.0 to 850.0	-100.0 to 1500.0



Additional Information

Fahrenheit temperature uses the following equation to convert the temperature unit from Celsius, but the temperature input range is different between Fahrenheit and Celsius.

Fahrenheit temperature (°F) = Celsius temperature (°C) × 1.8 + 32

3 Connect Temperature Sensors.

(1) Thermocouples

Either K or J thermocouples can be connected, but all twelve thermocouples must be the same type and the same input range.

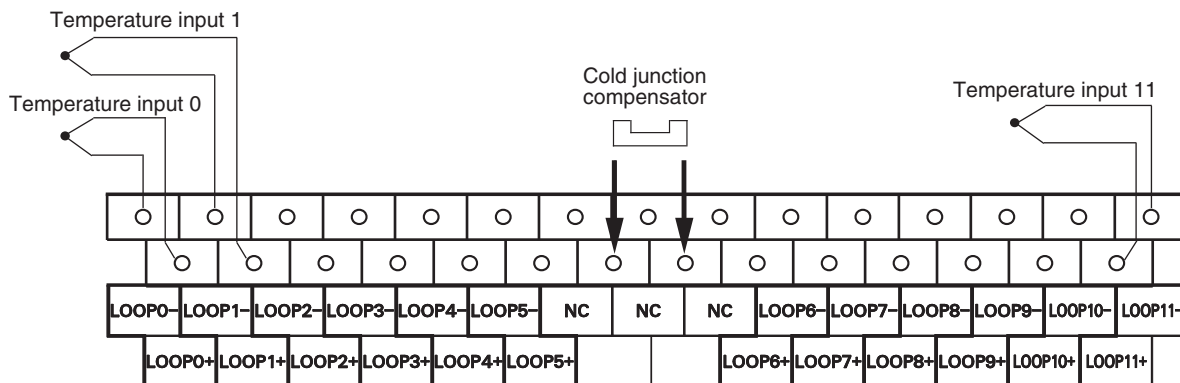

Precautions for Correct Use

When connecting a thermocouple input, observe the following precautions:

- Do not remove the cold junction compensator attached at the time of delivery. If the cold junction compensator is removed, the Unit will not be able to measure temperatures correctly.
- Each of the input circuits is calibrated with the cold junction compensator attached to the Unit. If the Unit is used with the cold junction compensator from other Units, the Unit will not be able to measure temperatures correctly.
- Do not touch the cold junction compensator. Doing so may result in incorrect temperature measurement.
- Use the thermocouple with metallic shield and connect the shield to ground.

4 Create the ladder program.

(1) Word Allocations

Temperature Sensor Units are allocated words in the same way as other CP-series Expansion Units or Expansion I/O Units, in order of connection. A Temperature Sensor Unit is allocated the next input words following the input words of the CPU Unit or previous Expansion Unit or Expansion I/O Unit. Two input words and one output word are allocated to CP1W-TS004.

- Example

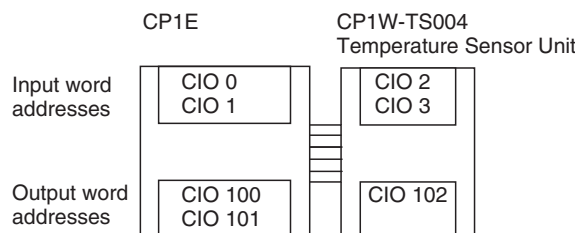

(2) Reading Temperature Data

There are 12 temperature input data to be read, but only two input words are allocated to CP1W-TS004. The operation is shown as the following.

- Input Word

m+1	Response. Input words stored in CIO m+2
m+2	Temperature data of the specified input word

- Output Word

n+1	Read command data (input word specified)
-----	--

- Read/Response Command and Temperature Data

Command	Output Word	Input Word	
	n+1	m+1	m+2
	Read command	Response command	Temperature data (4-digit hexadecimal)
Read temperature data from input 0	#9901	9901	Input 0 temperature data
Read temperature data from input 1	#9902	9902	Input 1 temperature data
Read temperature data from input 2	#9903	9903	Input 2 temperature data
Read temperature data from input 3	#9904	9904	Input 3 temperature data
Read temperature data from input 4	#9905	9905	Input 4 temperature data
Read temperature data from input 5	#9906	9906	Input 5 temperature data
Read temperature data from input 6	#9907	9907	Input 6 temperature data
Read temperature data from input 7	#9908	9908	Input 7 temperature data
Read temperature data from input 8	#9909	9909	Input 8 temperature data
Read temperature data from input 9	#990A	990A	Input 9 temperature data
Read temperature data from input 10	#990B	990B	Input 10 temperature data
Read temperature data from input 11	#990C	990C	Input 11 temperature data
Others	Others	No response for other commands	

- Negative values are stored as 2's complements.
- The converted temperature data CIO m+2 is stored in 16-bit binary data (4-digit hexadecimal).
- Data for range codes that include one digit after the decimal point are stored without the decimal point, i.e., 10 times the actual value is stored.

Input		Data conversion examples	
Unit: 0.1°C	K or J	×10	500.0°C → 5000 → 1388 hex -20.0°C → -200 → FF38 hex -200.0°C → -2000 → F830 hex

- If the input temperature exceeds the maximum or minimum value in the temperature input range that has been set by $\pm 20 \times C$ or $\pm 20 \times F$, the displayed value will be held.
- If the circuit is disconnected, the open-circuit detection function will operate and the converted temperature data will be set to 7FFF.
- The open-circuit detection function will be automatically cleared and normal input temperature conversion will begin automatically when the input temperature returns to the convertible range.

(3) Creating Ladder Program

- (1) Write temperature data command
Write temperature data command which read temperature data from input word to CIO n+1.
- (2) Response confirmation
After CP1W-TS004 receives CIO n+1 read command and CP1W-TS004's internally specified input temperature data is ready, the value which is the same as the read command will be stored in CIO m+1. The temperature data will be stored in CIO m+2 at the same time.
- (3) Read temperature data
Store the temperature data from CIO m+2 in DM area.

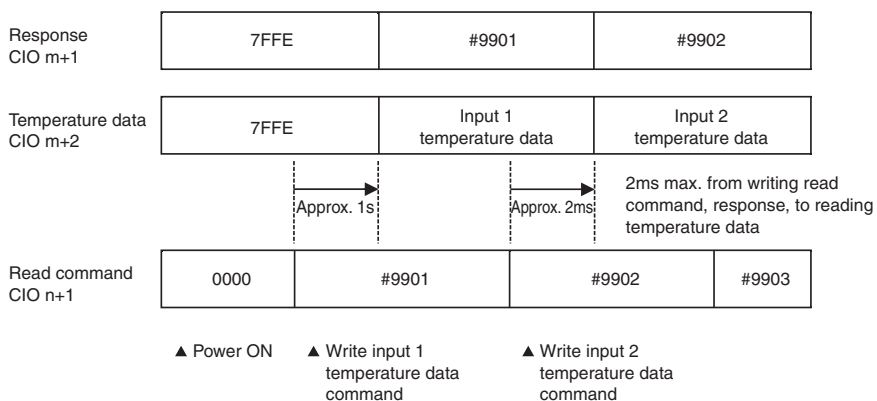
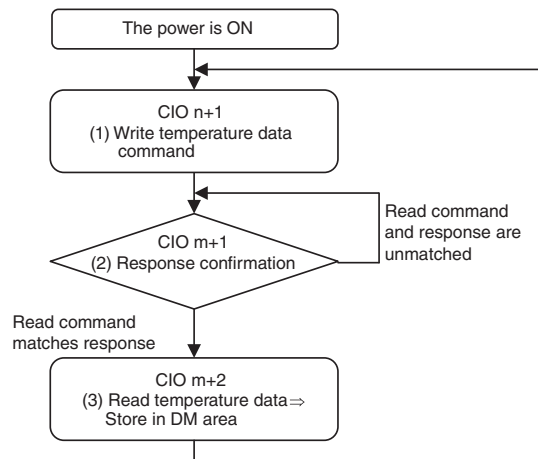

- Note 1** It takes about 2ms maximum until it is reflected to CIO m+1 and m+2 from writing the read command to CIO n+1.
- 2 It takes about 1s after the power is turned ON, till a read command initial processing of CP1W-TS004 is completed, so a response to the read command after power ON takes only about 1s. After the power is turned ON, create a ladder program 1s later due to its control by temperature data.
 - 3 When writing a command other than that specified in the temperature data read command, CIO m+1 and m+2 hold the previous value.

(4) Programming Example

The temperature data of CP1W-TS004 (12 inputs, input type is J type and temperature unit is °C) is stored in D0 to D11.

When it occurs open-circuit alarm, W10.00 to W10.11 is ON.

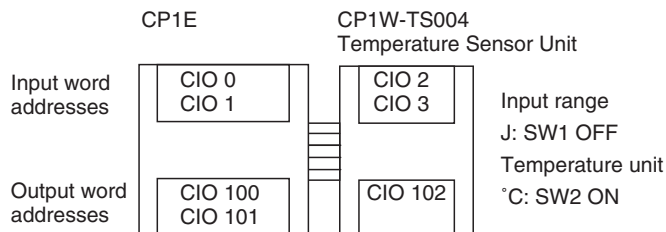

- Temperature Data Storage Address

Input word	Read command CIO n+1	Temperature data storage address	Open-circuit alarm
Input 0	#9901	D0	W0.00
Input 1	#9902	D1	W0.01
Input 2	#9903	D2	W0.02
Input 3	#9904	D3	W0.03
Input 4	#9905	D4	W0.04
Input 5	#9906	D5	W0.05
Input 6	#9907	D6	W0.06
Input 7	#9908	D7	W0.07
Input 8	#9909	D8	W0.08
Input 9	#990A	D9	W0.09
Input 10	#990B	D10	W0.10
Input 11	#990C	D11	W0.11

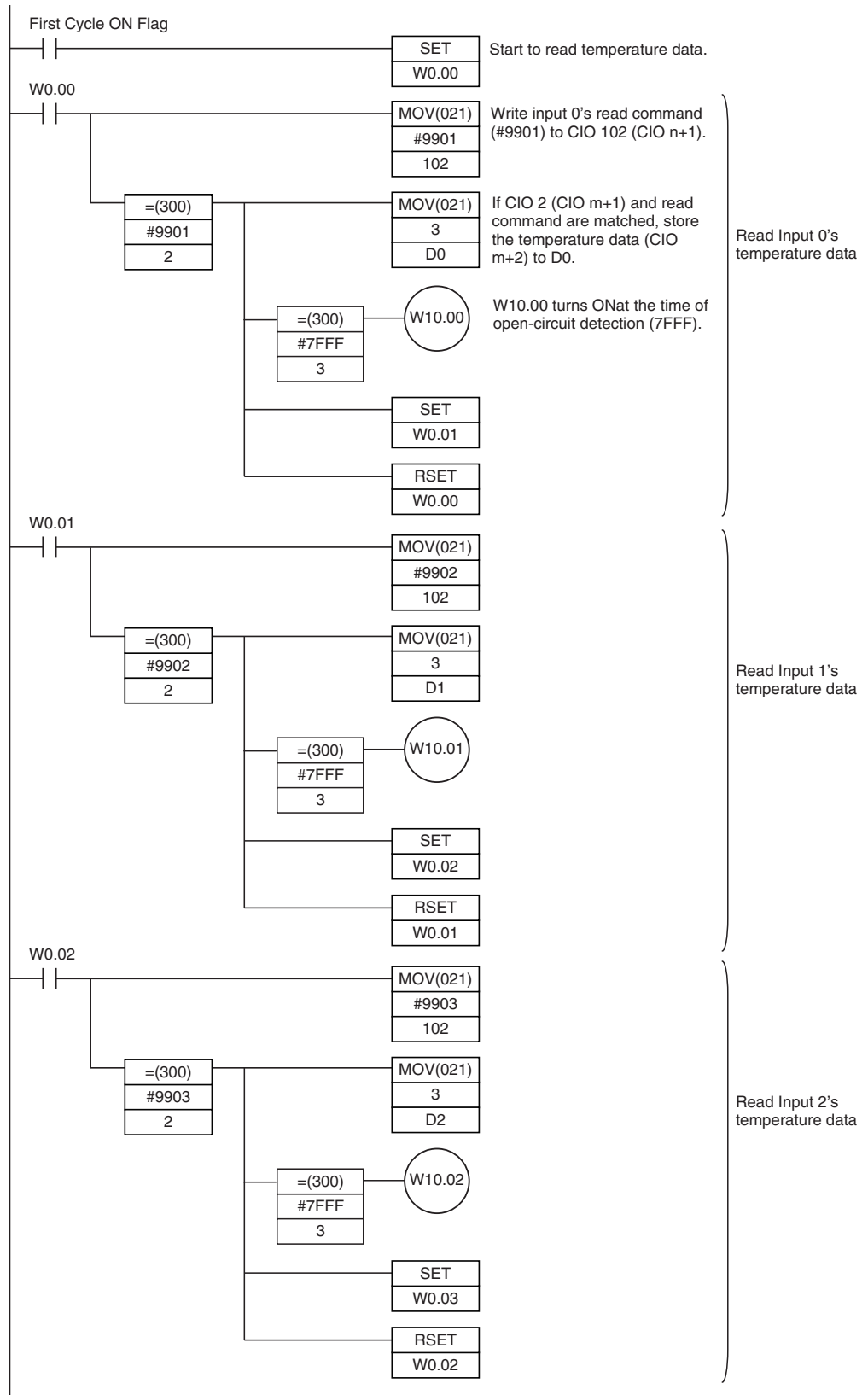

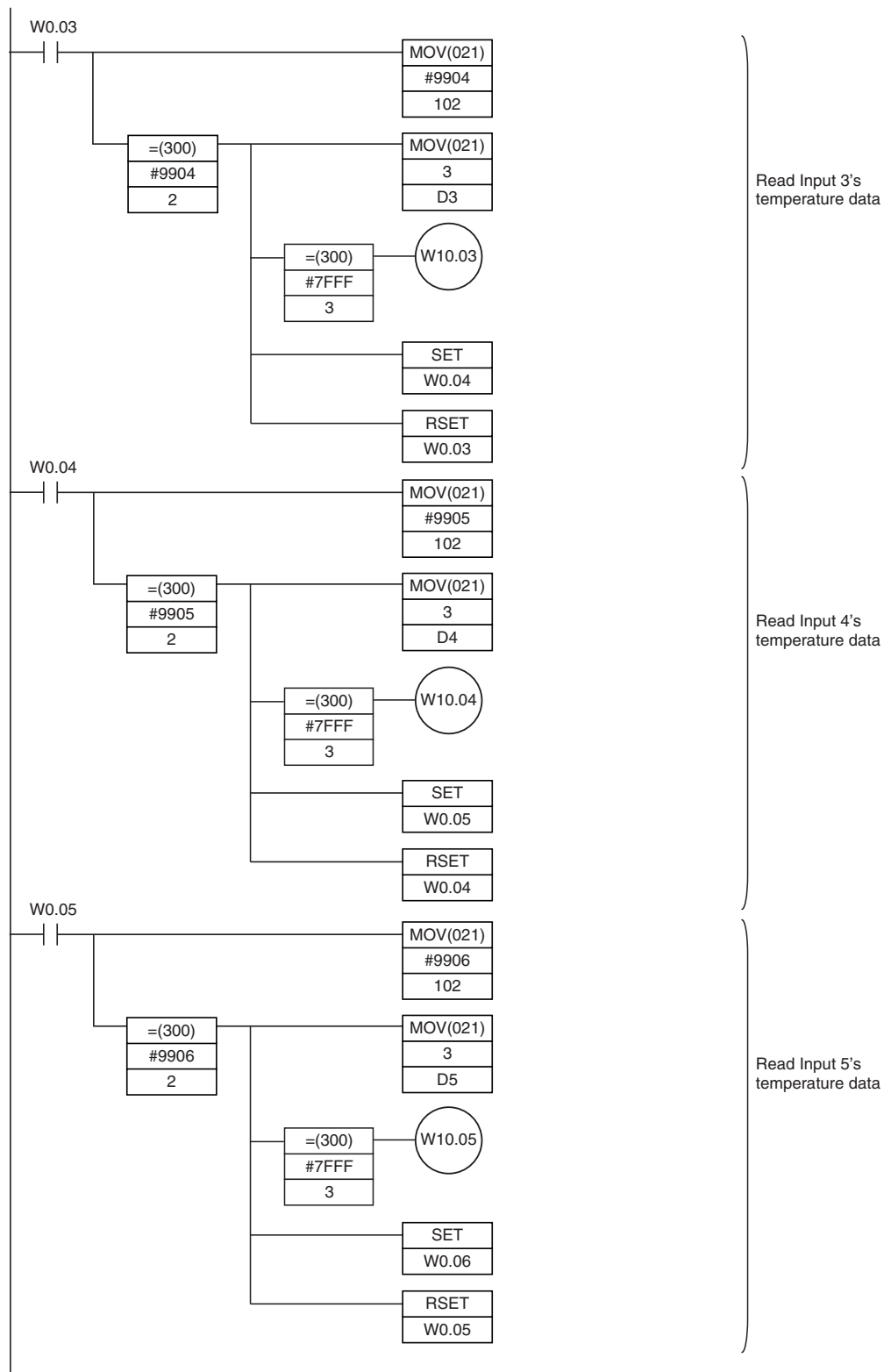

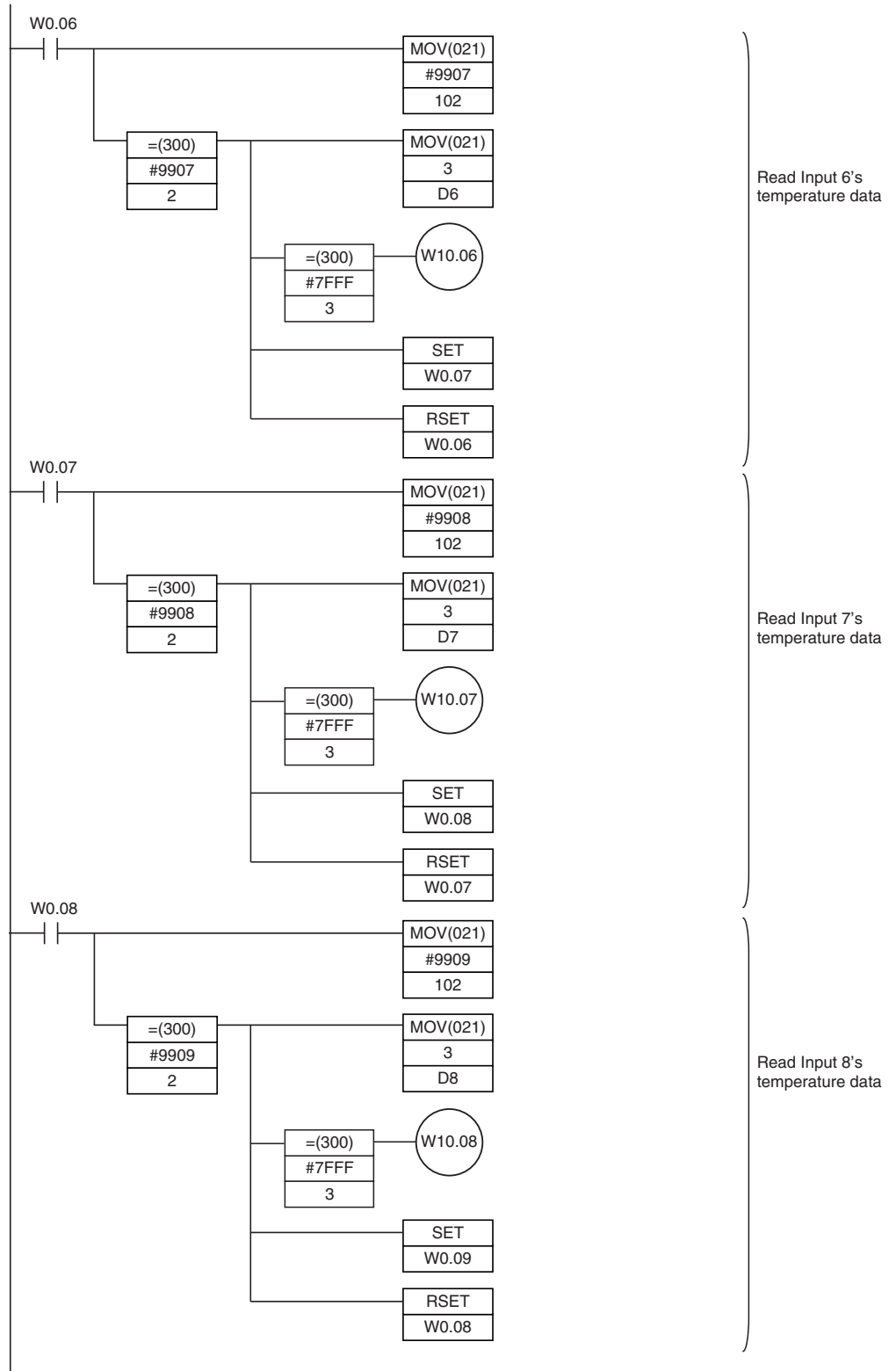

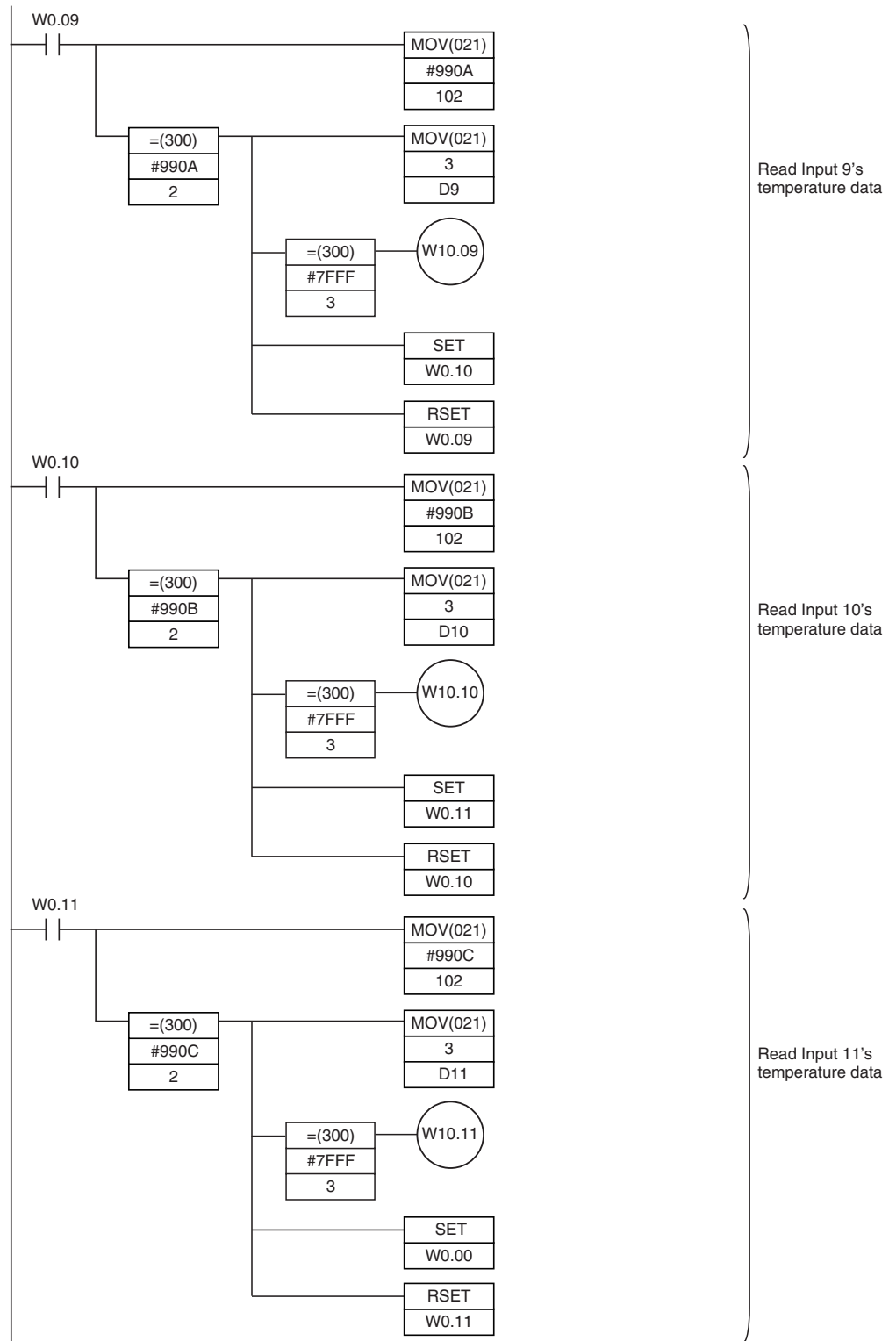

8-5 CompoBus/S I/O Link Units

8-5-1 Overview

The CP1E CPU Unit can function as a slave to a CompoBus/S Master Unit when a CP1W-SRT21 CompoBus/S I/O Link Unit is connected. The CompoBus/S I/O Link Unit establishes an I/O link of 8 inputs and 8 outputs between the Master Unit and the PLC.

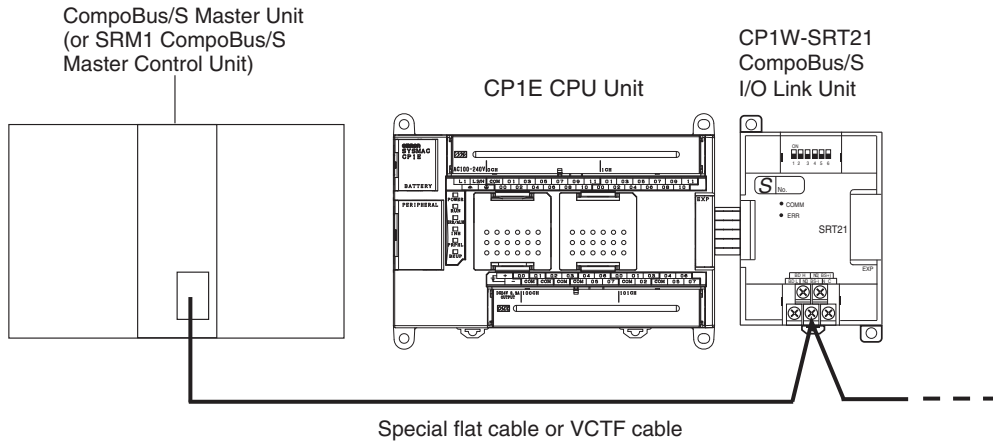

From the standpoint of the CP1E CPU Unit, the 8 input bits and 8 output bits allocated to the CompoBus/S I/O Link Unit are identical to input and output bits allocated to Expansion I/O Units even though the CompoBus/S I/O Link Unit does not control actual inputs and outputs, i.e., I/O is performed for I/O memory in the CPU Unit to which the CompoBus/S Master Unit is mounted.

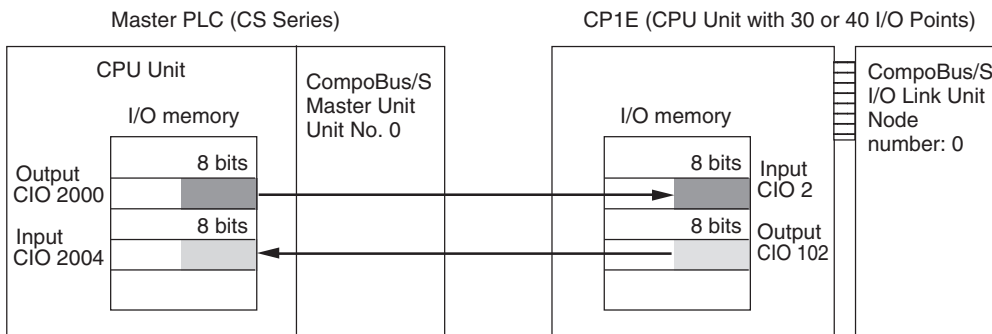

8-5-2 Part Names and Functions

● CP1W-SRT21 CompoBus/S I/O Link Unit

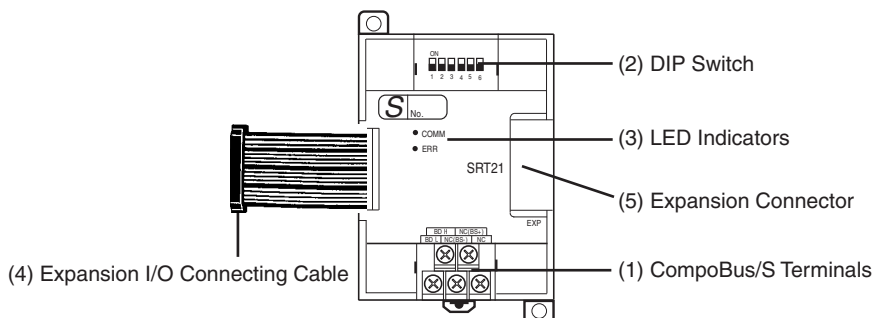

(1)CompoBus/S Terminals

The following CompoBus/S terminals are provided: CompoBus/S communications data high/low terminals, NC terminals for communications power supply plus (+) and minus (-), and an NC terminal. (Power is supplied internally for this Unit, so the NC terminals for communications power supply can be used as relay terminals.)

(2)DIP Switch

Used to specify the node number for the CompoBus/S I/O Link Unit.

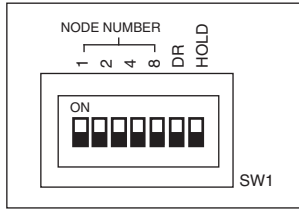

* The long-distance communications mode can be used only when one of the following Master Units is connected: C200HW-SRM21-V1, CQM1-SRM21-V1, SRM1-C0□-V2, CS1W-SRM21 or CJ1W-SRM21.

Pin labels	Contents																																																																																														
1	<table border="1"> <thead> <tr> <th>Node Number Setting</th> <th colspan="4">SW1</th> </tr> <tr> <th></th> <th>8</th> <th>4</th> <th>2</th> <th>1</th> </tr> </thead> <tbody> <tr><td>0</td><td>0</td><td>0</td><td>0</td><td>0</td></tr> <tr><td>1</td><td>0</td><td>0</td><td>0</td><td>1</td></tr> <tr><td>2</td><td>0</td><td>0</td><td>1</td><td>0</td></tr> <tr><td>3</td><td>0</td><td>0</td><td>1</td><td>1</td></tr> <tr><td>4</td><td>0</td><td>1</td><td>0</td><td>0</td></tr> <tr><td>5</td><td>0</td><td>1</td><td>0</td><td>1</td></tr> <tr><td>6</td><td>0</td><td>1</td><td>1</td><td>0</td></tr> <tr><td>7</td><td>0</td><td>1</td><td>1</td><td>1</td></tr> <tr><td>8</td><td>1</td><td>0</td><td>0</td><td>0</td></tr> <tr><td>9</td><td>1</td><td>0</td><td>0</td><td>1</td></tr> <tr><td>10</td><td>1</td><td>0</td><td>1</td><td>0</td></tr> <tr><td>11</td><td>1</td><td>0</td><td>1</td><td>1</td></tr> <tr><td>12</td><td>1</td><td>1</td><td>0</td><td>0</td></tr> <tr><td>13</td><td>1</td><td>1</td><td>0</td><td>1</td></tr> <tr><td>14</td><td>1</td><td>1</td><td>1</td><td>0</td></tr> <tr><td>15</td><td>1</td><td>1</td><td>1</td><td>1</td></tr> </tbody> </table> <p>1 = ON, 0 = OFF</p>					Node Number Setting	SW1					8	4	2	1	0	0	0	0	0	1	0	0	0	1	2	0	0	1	0	3	0	0	1	1	4	0	1	0	0	5	0	1	0	1	6	0	1	1	0	7	0	1	1	1	8	1	0	0	0	9	1	0	0	1	10	1	0	1	0	11	1	0	1	1	12	1	1	0	0	13	1	1	0	1	14	1	1	1	0	15	1	1	1	1
Node Number Setting						SW1																																																																																									
						8	4	2	1																																																																																						
0						0	0	0	0																																																																																						
1						0	0	0	1																																																																																						
2						0	0	1	0																																																																																						
3						0	0	1	1																																																																																						
4						0	1	0	0																																																																																						
5						0	1	0	1																																																																																						
6						0	1	1	0																																																																																						
7						0	1	1	1																																																																																						
8						1	0	0	0																																																																																						
9						1	0	0	1																																																																																						
10						1	0	1	0																																																																																						
11						1	0	1	1																																																																																						
12	1	1	0	0																																																																																											
13	1	1	0	1																																																																																											
14	1	1	1	0																																																																																											
15	1	1	1	1																																																																																											
DR	ON	Long-distance communications mode *																																																																																													
	OFF	High-speed communications mode																																																																																													
HOLD	ON	Retain outputs after a communications error.																																																																																													
	OFF	Clear outputs after a communications error.																																																																																													

(3)LED Indicators

Used to show the CompoBus/S communications status.

Indicator	Name	Color	Meaning
COMM	Communications indicator	Yellow	ON: Communications in progress. OFF: Communications stopped or error has occurred.
ERR	Error indicator	Red	ON: A communications error has occurred. OFF: Indicates normal communications or stand-by.

(4)Expansion I/O Connecting Cable

Connected to the expansion connector of a CP1E CPU Unit or an Expansion Unit or Expansion I/O Unit. The cable is provided with the CompoBus/S I/O Link Unit and cannot be removed.



Precautions for Safe Use

Do not touch the cables during operation. Static electricity may cause operating errors.

(5)Expansion Connector

Used to connect Expansion Units or Expansion I/O Units.

8-5-3 Specifications

Model	CP1W-SRT21
Master/slave	CompoBus/S Slave
Number of I/O points	8 input points, 8 output points
Number of words allocated in CPU Unit I/O memory	1 input word, 1 output word
Node number setting	Set using the DIP switch (Set before turning on the CPU Unit's power supply.)

8-5-4 Flow of Operation

- 1** Connect the Unit.

 - Connect the CompoBus/S I/O Link Unit.
- ↓

2 Determine the node number of the CompoBus/S I/O Link Unit and set the DIP switch.

 - The node number should be a unique number between 0 and 15.
 - Use the DIP switch to set the CompoBus/S I/O Link Unit's node number, communications mode, and the status of output data when a communications error occurs.
- ↓

3 Wire the CompoBus/S transmission path.

 - Connect the CompoBus/S I/O Link Unit to a CompoBus/S transmission path.

- 1** Connect the CompoBus/S I/O Link Unit to the CPU Unit.

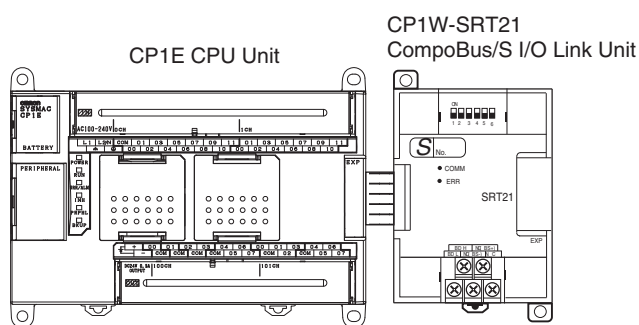

● I/O Words Allocation

I/O words are allocated to the CompoBus/S I/O Link Unit in the same way as to other Expansion Units and Expansion I/O Units, i.e., the next available input and output words are allocated. As shown below, when “m” is the last allocated input word and “n” is the last allocated output word, the CompoBus/S I/O Link Unit is allocated “m+1” as its input word and “n+1” as its output word.

CompoBus/S I/O Link Unit

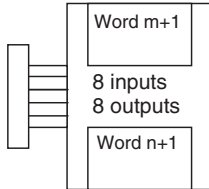

In the following example, a CompoBus/S I/O Link Unit is connected as the first Unit after the CP1E CPU Unit.

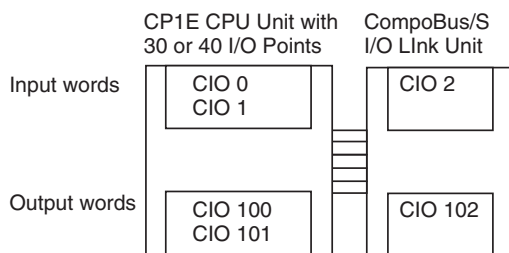

The input word (m+1) contains the data from the Master Unit and the CompoBus/S communications status.

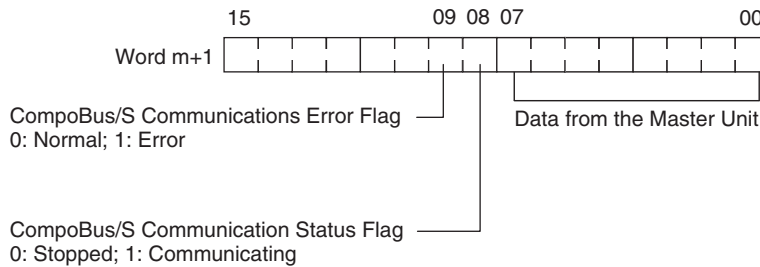

Write the data to be transmitted to the Master Unit in the output word (n+1).

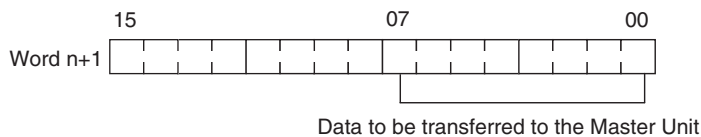

Precautions for Correct Use

The 8 bits of I/O data are not always transmitted simultaneously.

- 8 bits of data transmitted from the Master CPU Unit at the same time will not always reach the CP1E CPU Unit.
- 8 bits of data transmitted from the CP1E CPU Unit at the same time will not always reach the Master CPU Unit simultaneously.

When the 8 bits of input data must be read together, modify the ladder program in the CPU Unit receiving the data. For example, read the input data twice in succession and accept the data only when the two values match.



Additional Information

- Unused bits in the CompoBus/S I/O Link Unit's output words can be used as work bits.
- Unused bits in input word cannot be used as work bits.

2 Determine the node number and make DIP switch settings.

(1) Determining Node Number

- The CompoBus/S I/O Link Unit is a Slave Unit with 8 input bits and 8 output bits. The node number setting is made using the DIP switch; the inputs and outputs share the same node number.
- The range of possible node number settings is determined by the type of PLC the Master Unit is mounted to and the settings on the Master Unit.
For details, refer to the *CompoBus/S Operation Manual* (Cat. No. W266).

(2) Making DIP Switch Settings

Use the DIP switch to set the CompoBus/S I/O Link Unit's node number, communications mode, and the status of output data when a communications error occurs.



Precautions for Correct Use

Always turn OFF the power supply before changing the DIP switch settings.

3 Wire the CompoBus/S communications path.

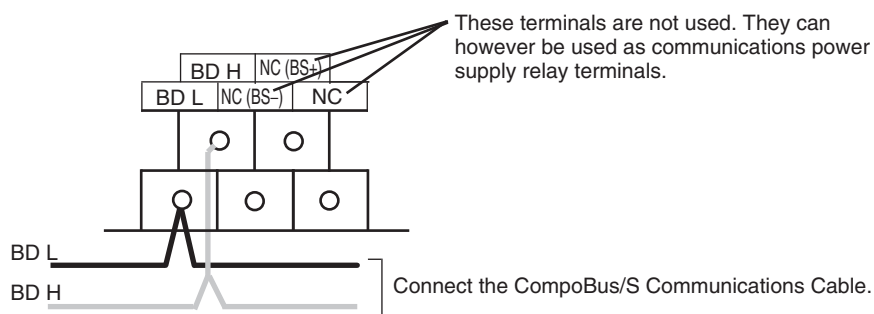

App

Appendices

A-1	Dimensions	A-2
A-1-1	CPU Units	A-2
A-1-2	Option Boards	A-5
A-1-3	Expansion I/O Units	A-8
A-1-4	Expansion Units	A-10
A-2	Wiring Diagrams	A-12
A-2-1	CPU Units	A-12
A-2-2	Expansion I/O Units	A-21
A-2-3	Expansion Units	A-28
A-2-4	Serial Communications	A-39
A-3	Wiring for Serial Communications	A-44
A-3-1	Recommended RS-232C Wiring	A-44
A-3-2	Recommended RS-422A/485 Wiring	A-47
A-3-3	Converting the Built-in RS-232C Port to RS-422A/485	A-50
A-3-4	Reducing Electrical Noise for External Wiring	A-53

A-1 Dimensions

A-1-1 CPU Units

CPU Units with 10 I/O Points

- CP1E-E10D□-□

Unit: mm

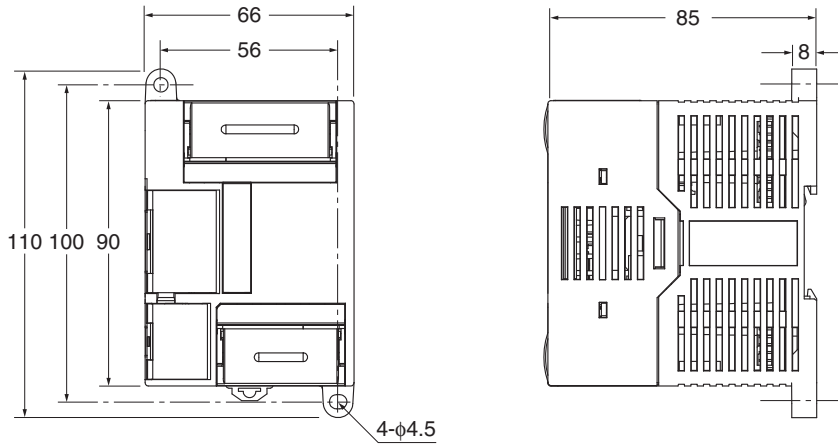

CPU Units with 14 or 20 I/O Points

- CP1E-□14D□-□/□20D□-□

Unit: mm

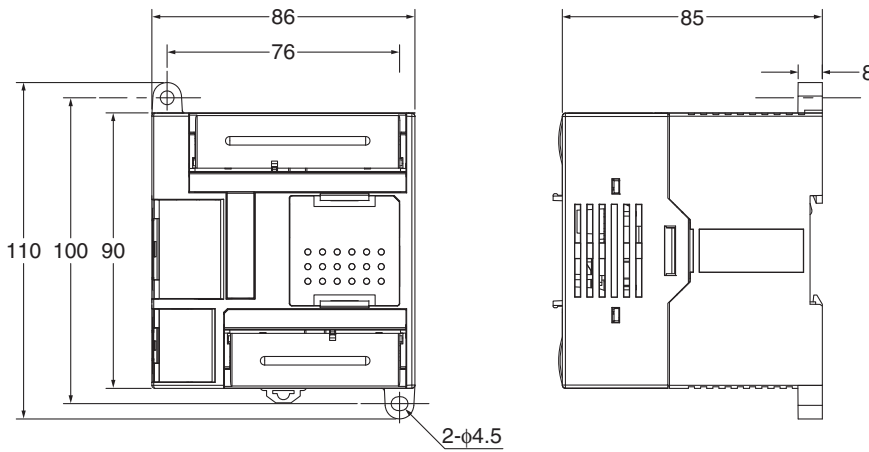

● CP1E-E14/20SD□-□

Unit: mm

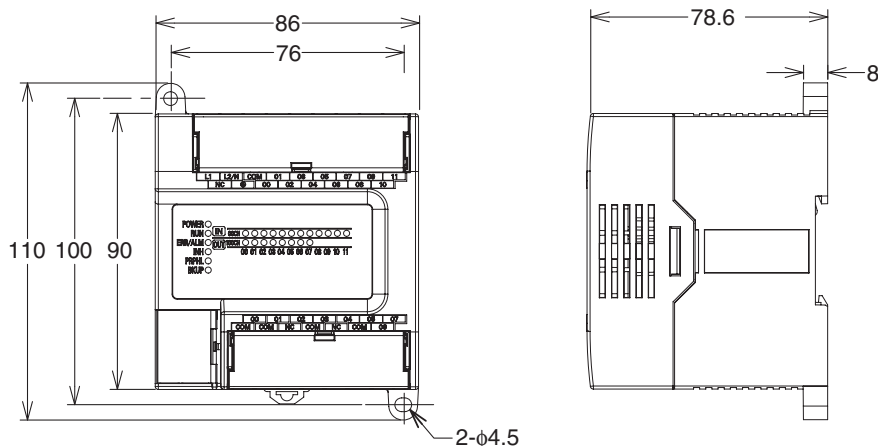

CPU Units with 30 I/O Points
CPU Units with Built-in Analog and 20 I/O Points

● CP1E-□30D□-□, CP1E-NA20D□-□

Unit: mm

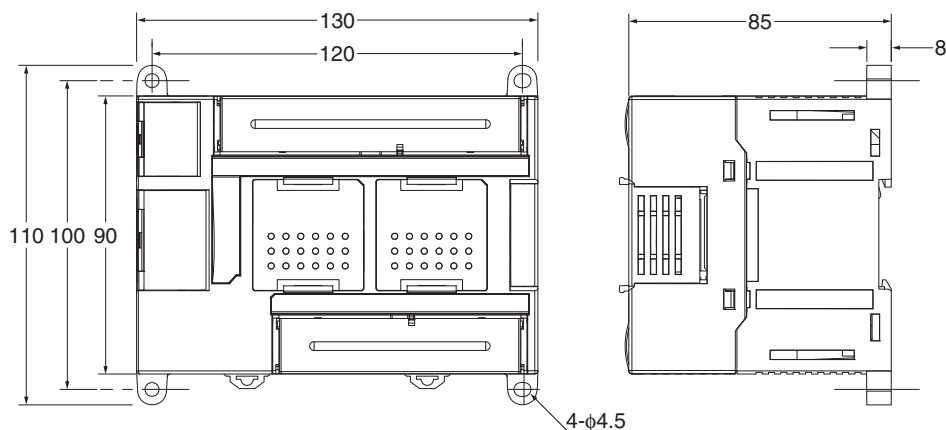

● CP1E-□30S(1)D□-□

Unit: mm

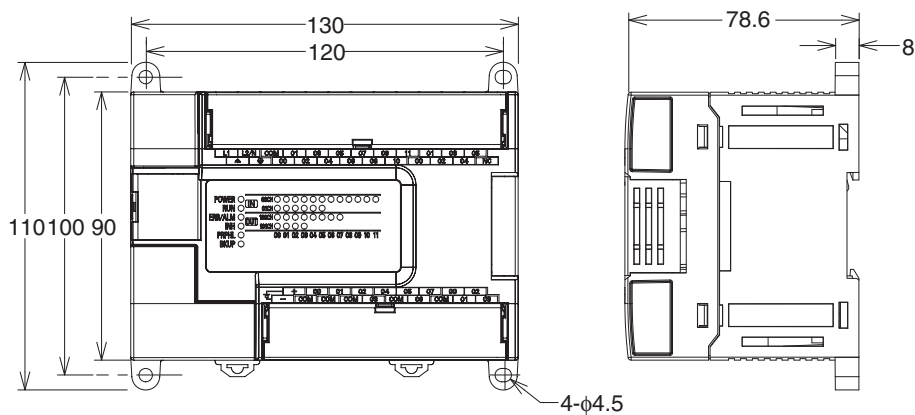

CPU Units with 40 I/O Points

● CP1E-□40D□-□

Unit: mm

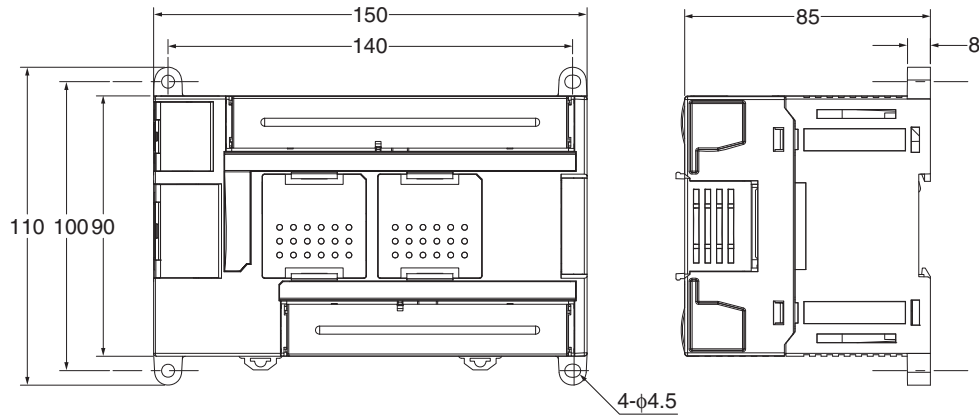

● CP1E-□40S(1)D□-□

Unit: mm

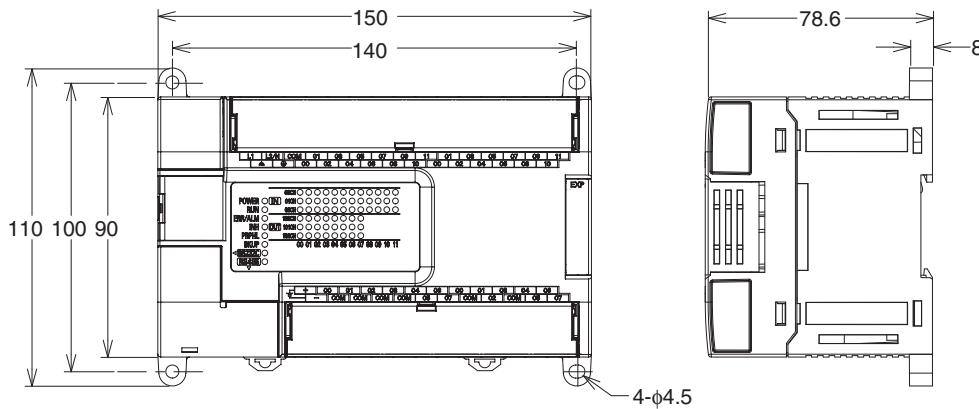

CPU Units with 60 I/O Points

● CP1E-N60D□-□

Unit: mm

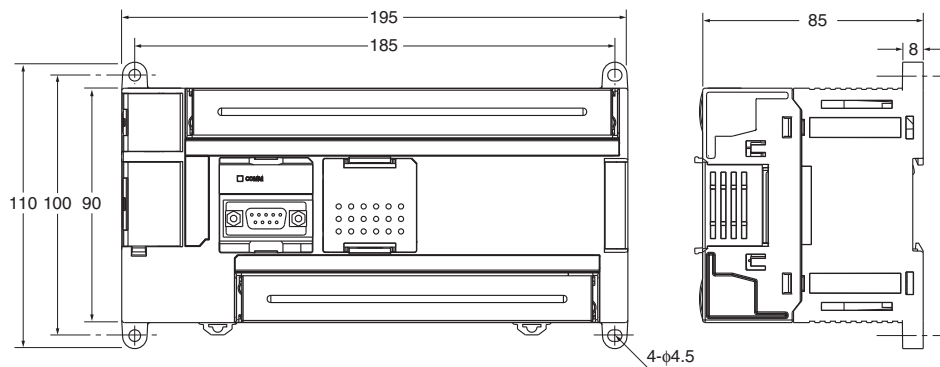

● CP1E-□60S(1)D□-□

Unit: mm

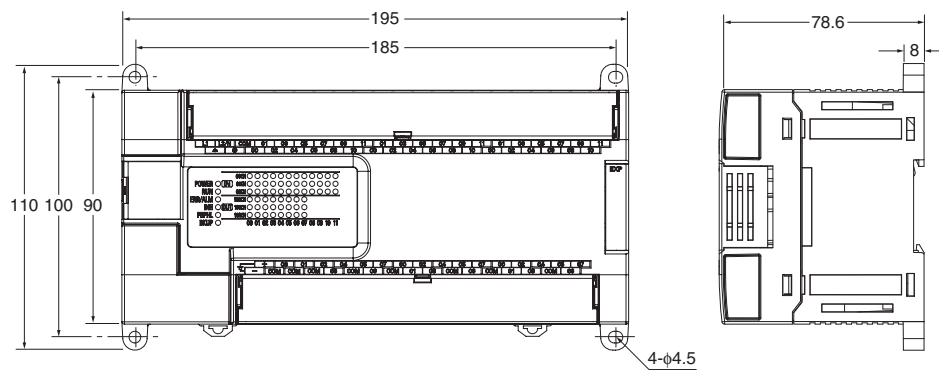

A-1-2 Option Boards

CP1W-CIF01 RS-232C Option Board

Unit: mm

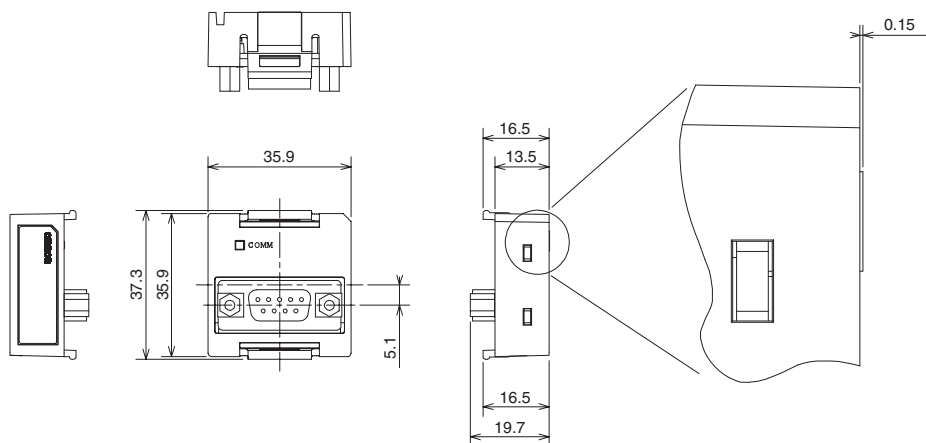

CP1W-CIF11/CIF12-V1 RS-422A/485 Option Board

Unit: mm

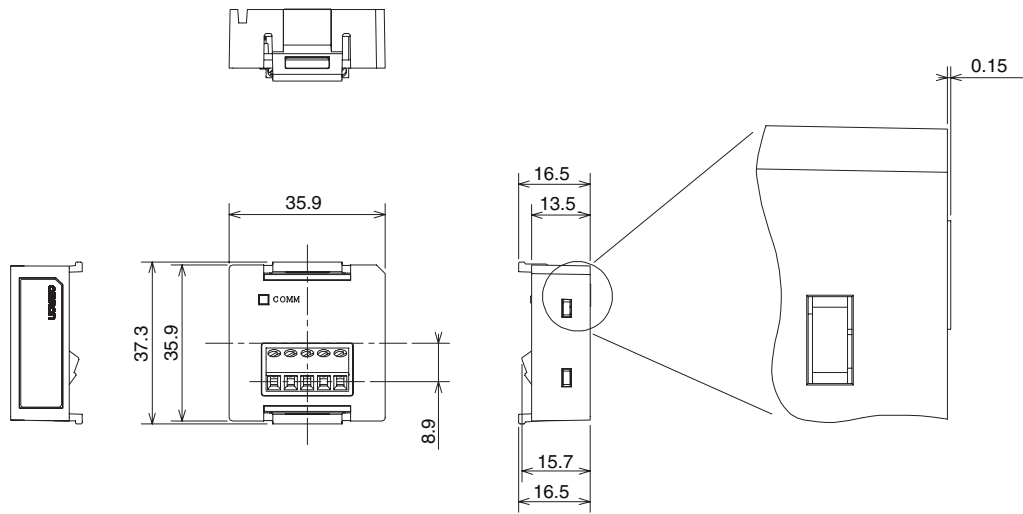

CP1W-CIF12 RS-422A/485 Option Board (Not include CP1W-CIF12-V1)

Unit: mm

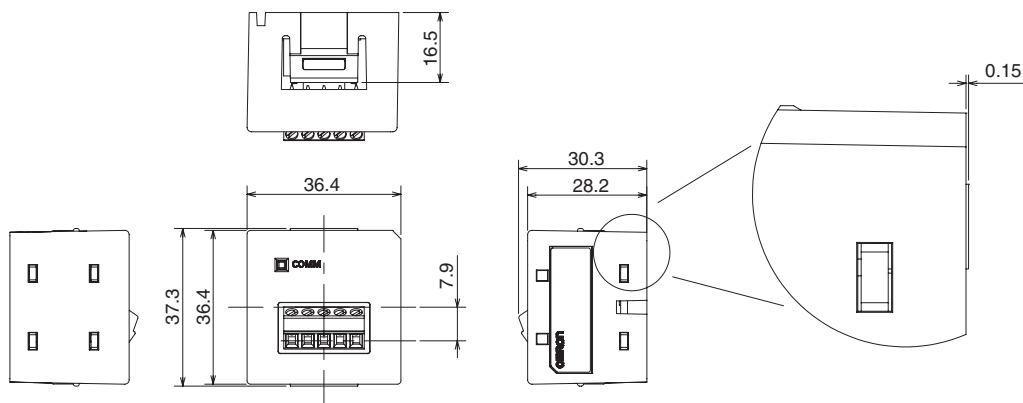

CP1W-CIF41 Ethernet Option Board

Unit: mm

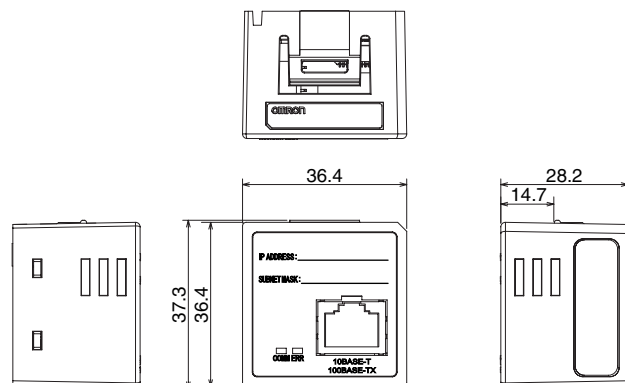

CP1W-MAB221 Analog Input/Output Option Board

Unit: mm

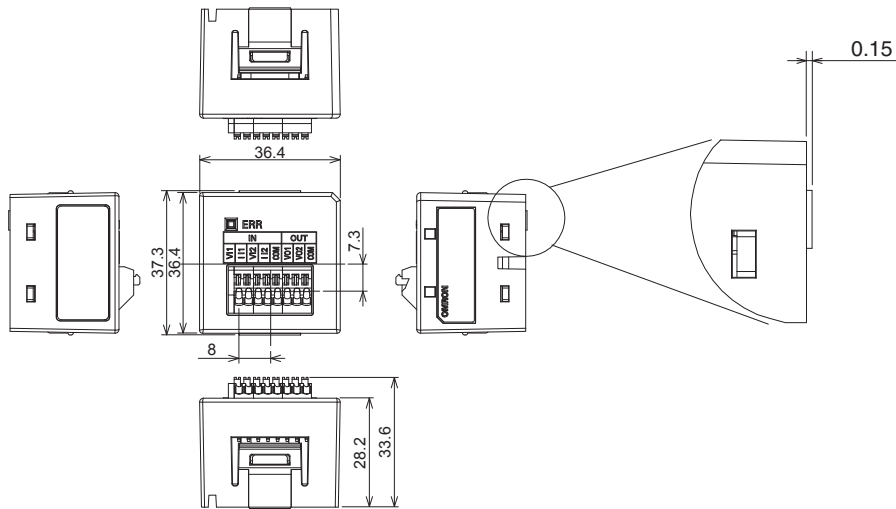

CP1W-ADB21 Analog Input Option Board

Unit: mm

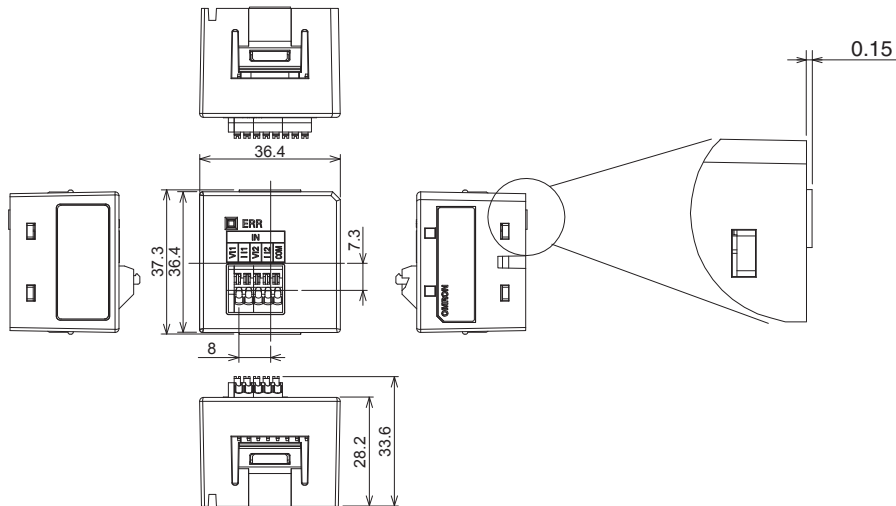

CP1W-DAB21V Analog Output Option Board

Unit: mm

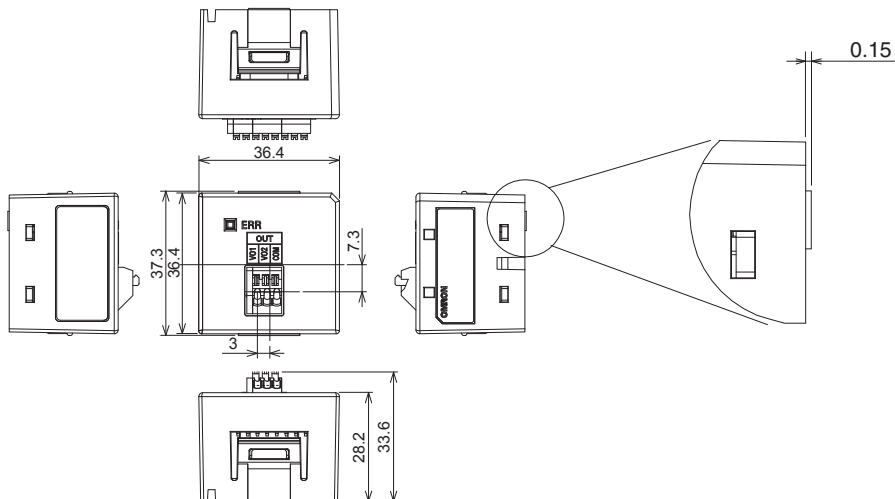

A-1-3 Expansion I/O Units

CP1W-8ED Expansion I/O Unit with 8 Input Points

Unit: mm

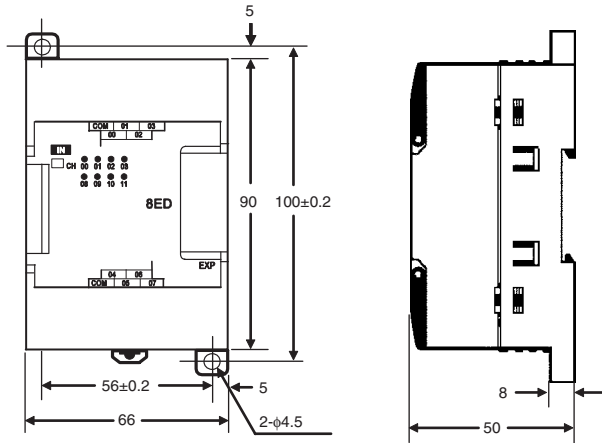

CP1W-8E□ Expansion I/O Units with 8 Output Points

Unit: mm

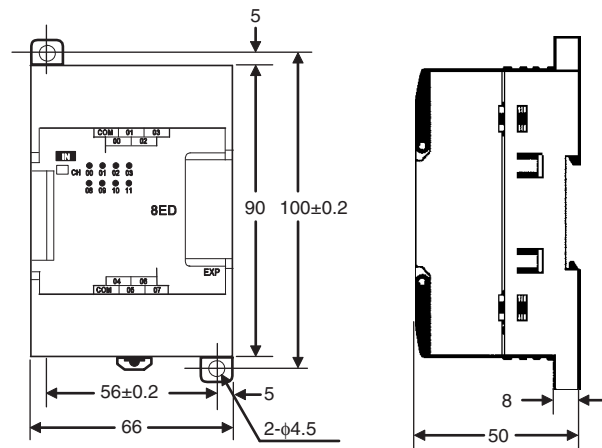

CP1W-16E□□ Expansion I/O Units with 16 Output Points

Unit: mm

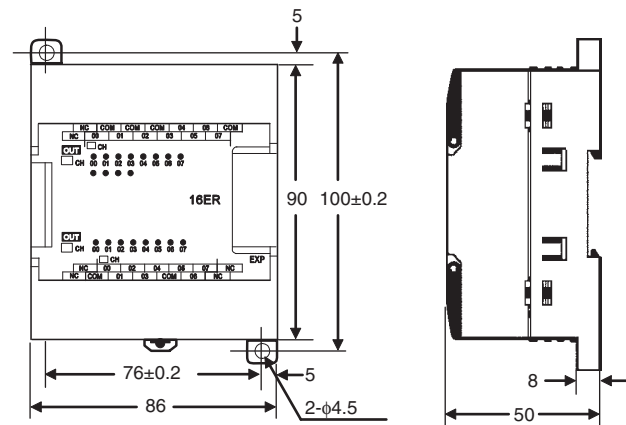

CP1W-32ER/ET/ET1 Expansion I/O Units with 32 Output Points

Unit: mm

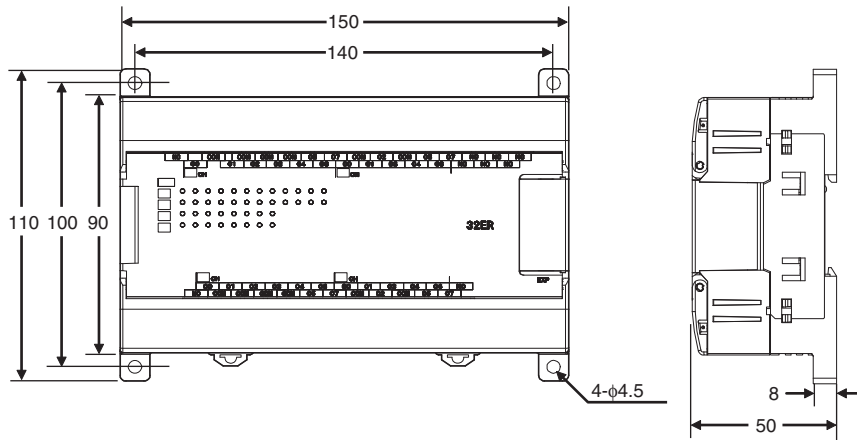

CP1W-20ED□□ Expansion I/O Units with 20 I/O Points

Unit: mm

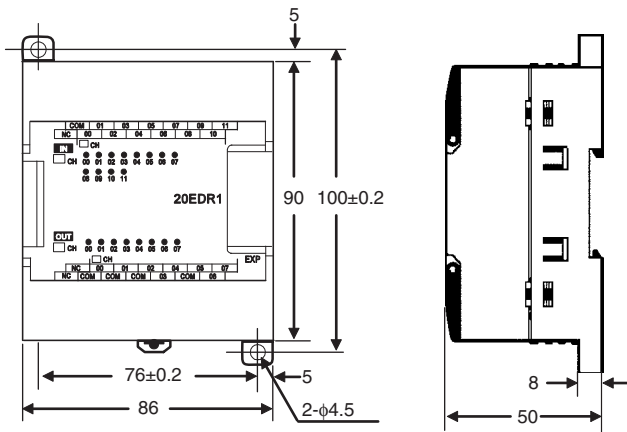

CP1W-40ED□□ Expansion I/O Units with 40 I/O Points

Unit: mm

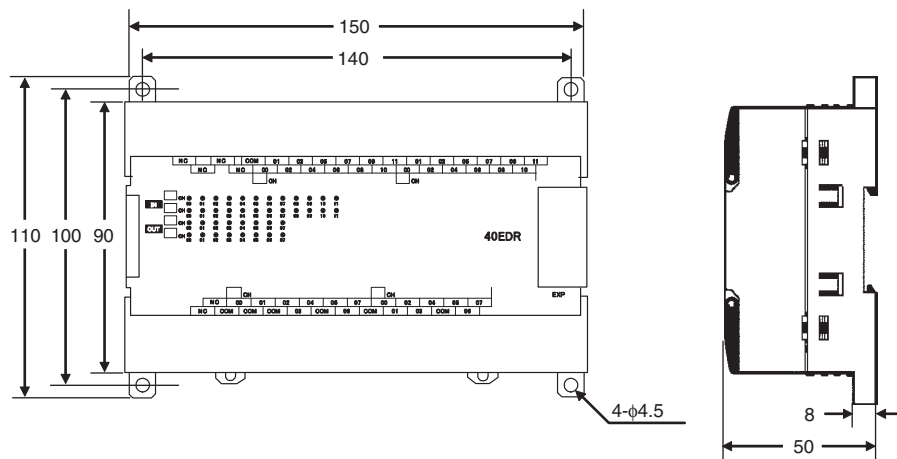

A-1-4 Expansion Units

CP1W-MAD11/MAD42/MAD44 Analog I/O Units

Unit: mm

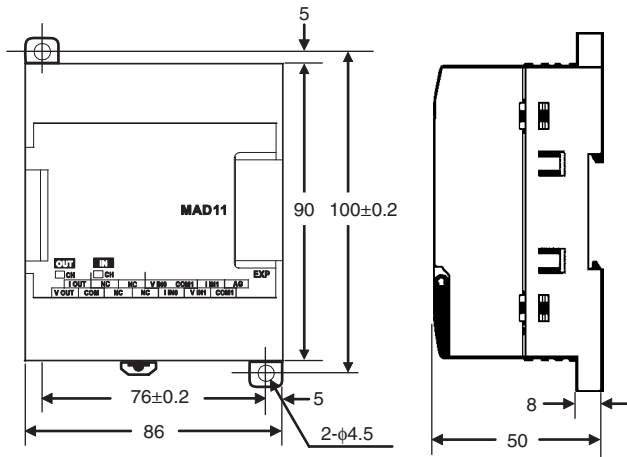

CP1W-AD041/AD042 Analog Input Unit

Unit: mm

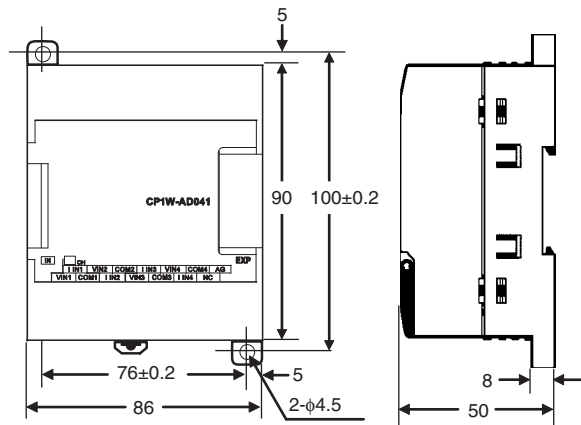

CP1W-DA021/DA041/DA042 Analog Output Unit

Unit: mm

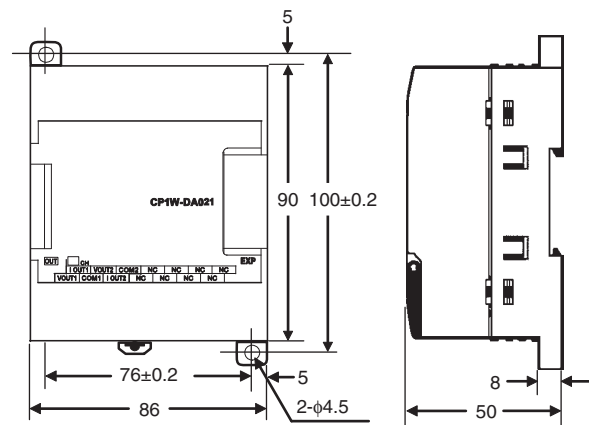

CP1W-TS□□1/2/3 Temperature Sensor Units

Unit: mm

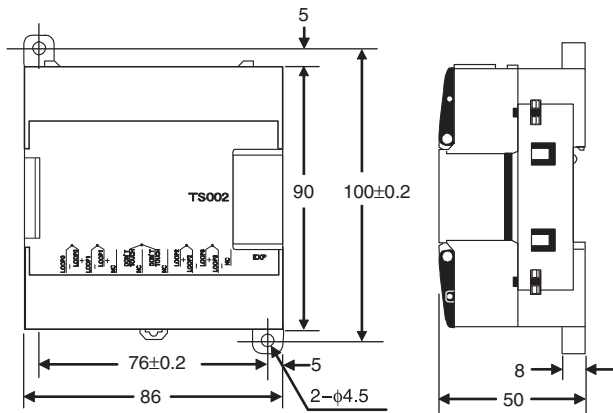

CP1W-TS004 Temperature Sensor Units

Unit: mm

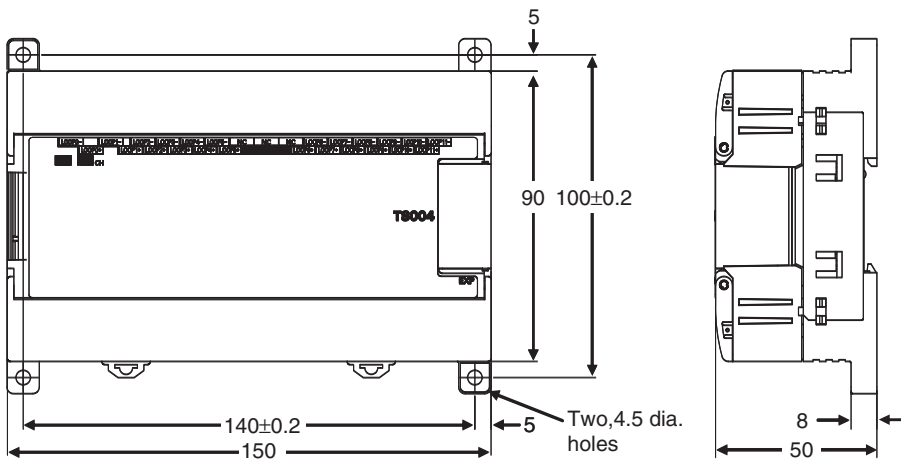

CP1W-SRT21 CompoBus/S I/O Link Unit

Unit: mm

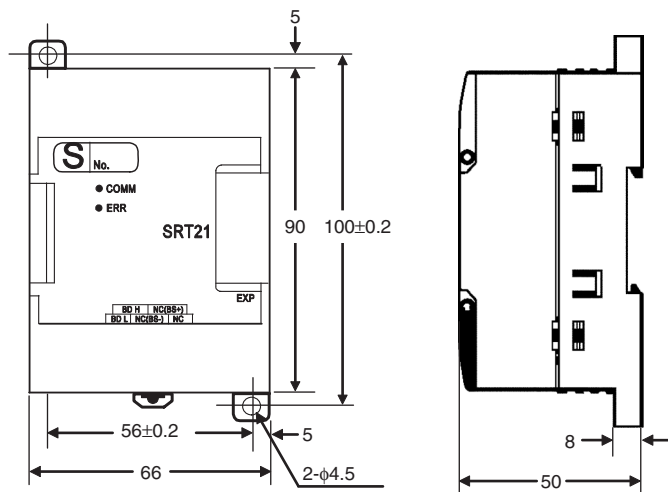

A-2 Wiring Diagrams

A-2-1 CPU Units

CPU Unit with 10 I/O Points (Terminal Block is not removable)

Input Wiring Diagram	Output Wiring Diagram
<p>● All Models</p> <p>AC Power Supply CP1E-E10D□□-A</p> <p>DC Power Supply CP1E-E10D□□-D</p>	<p>● Relay Outputs</p> <p>CP1E-E10DR-□</p> <p>● Transistor Outputs (Sinking)</p> <p>CP1E-E10DT-□</p> <p>● Transistor Outputs (Sourcing)</p> <p>CP1E-E10DT1-□</p>

CPU Unit with 14 I/O Points (Terminal Block is not removable)

Input Wiring Diagram

● **All Models**

AC Power Supply

CP1E-E14DR-A/E14SDR-A

CP1E-N14D□□-A

DC Power Supply

CP1E-N14D□□-D

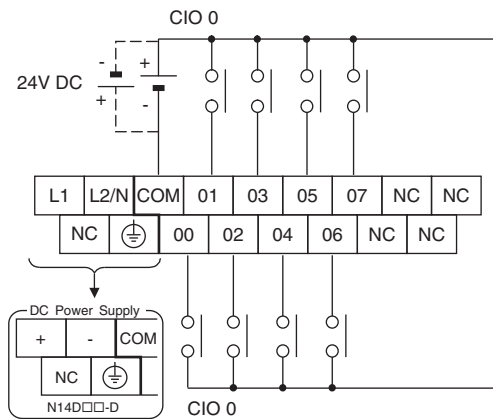

Output Wiring Diagram

● **Relay Outputs**

CP1E-E14DR-A/E14SDR-A

CP1E-N14DR-□

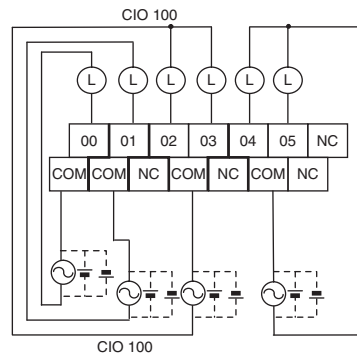

● **Transistor Outputs (Sinking)**

CP1E-N14DT-□

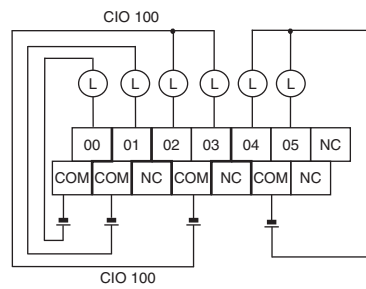

● **Transistor Outputs (Sourcing)**

CP1E-N14DT1-□

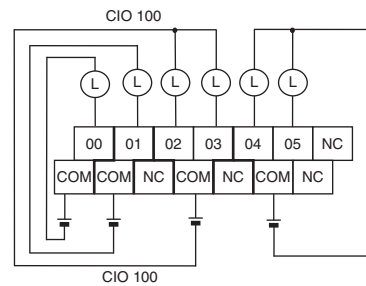

CPU Unit with 20 I/O Points (Terminal Block is not removable)

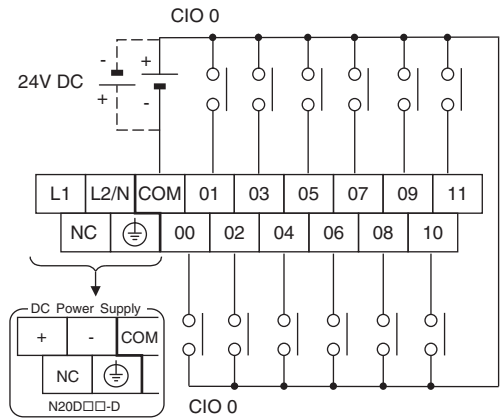
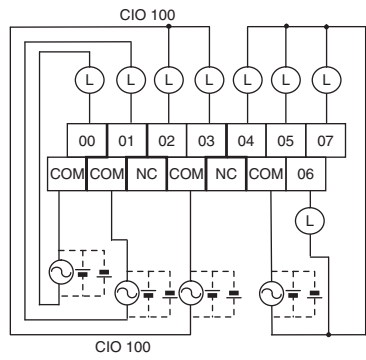
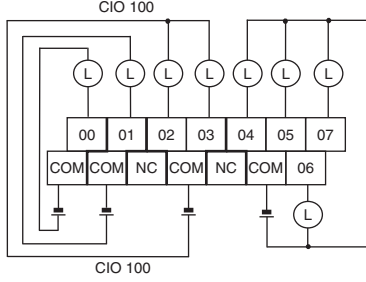
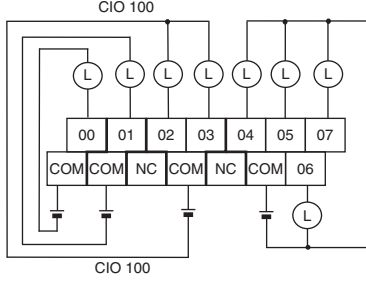
Input Wiring Diagram	Output Wiring Diagram
<p>● All Models</p> <p>AC Power Supply CP1E-E20DR-A/E20SDR-A CP1E-N20D□□-A DC Power Supply CP1E-N20D□□-D</p> 	<p>● Relay Outputs</p> <p>CP1E-E20DR-A/E20SDR-A CP1E-N20DR-□</p>  <p>● Transistor Outputs (Sinking)</p> <p>CP1E-N20DT-□</p>  <p>● Transistor Outputs (Sourcing)</p> <p>CP1E-N20DT1-□</p> 

CPU Units with 30 I/O Points (Terminal Block is not removable)

Input Wiring Diagram

● **All Models**

AC Power Supply

CP1E-E30DR-A/E30SDR-A

CP1E-N30D□□-A/N30S(1)D□□-A

DC Power Supply

CP1E-N30D□□-D/N30S(1)D□□-D

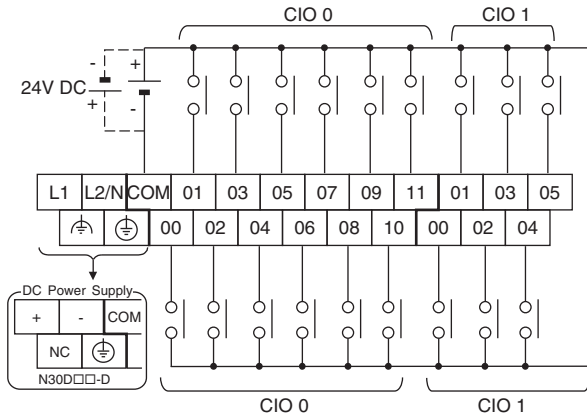

Output Wiring Diagram

● **Relay Outputs**

CP1E-□30DR-□/□30SDR-A

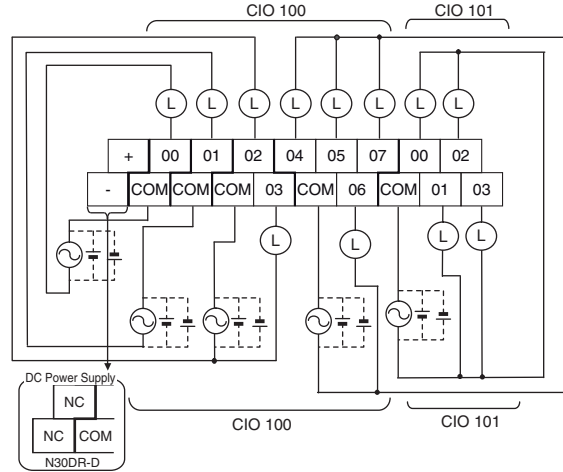

● **Transistor Outputs (Sinking)**

CP1E-N30S(1)DT-D

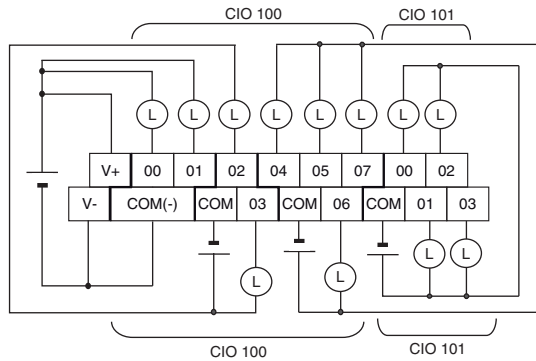

CP1E-N30DT-□

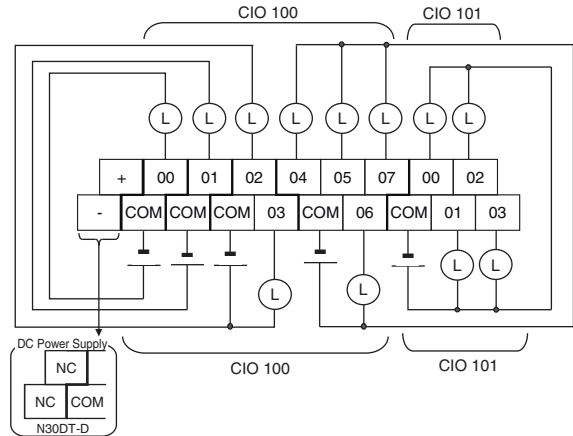

● **Transistor Outputs (Sourcing)**

CP1E-N30S(1)DT1-D

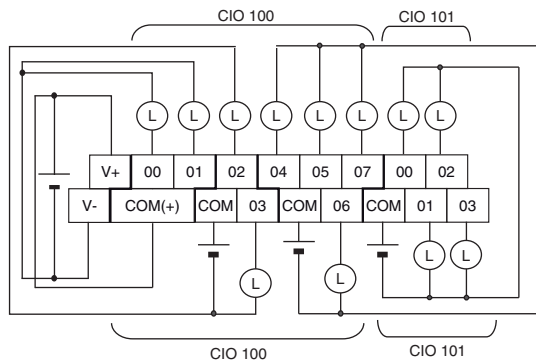

CP1E-N30DT1-□

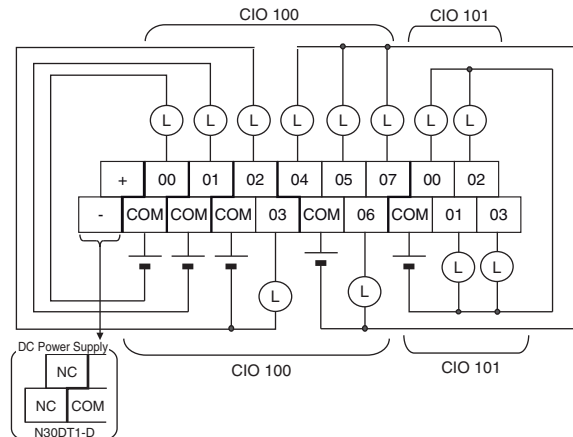

CPU Units with 40 I/O Points (Terminal Block is not removable)

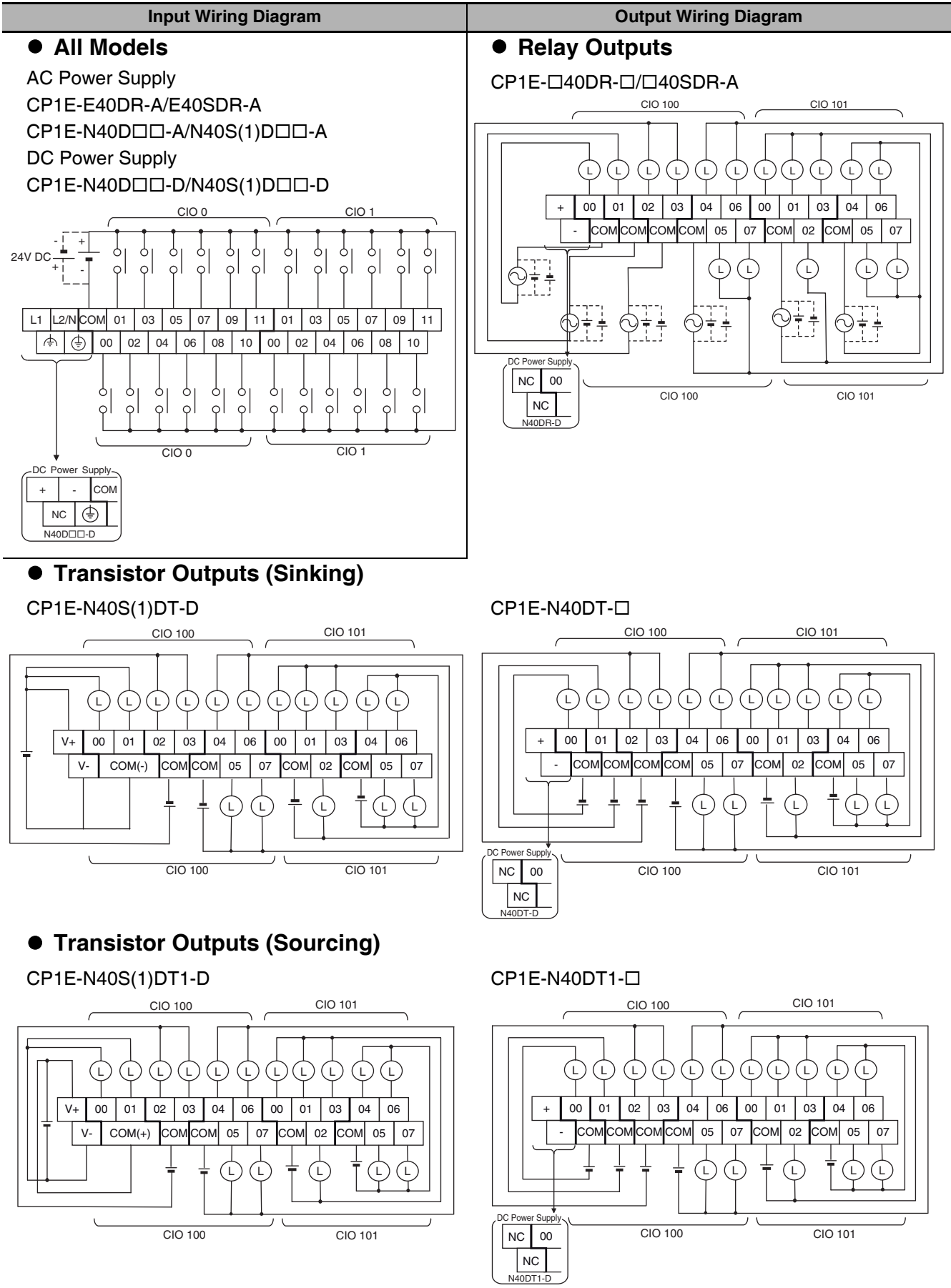

CPU Units with 60 I/O Points (Terminal Block is not removable)

Input Wiring Diagram

● All Models

AC Power Supply

CP1E-E60SDR-A

CP1E-N60D□□-A/N60S(1)D□□-A

DC Power Supply

CP1E-N60D□□-D/N60S(1)D□□-D

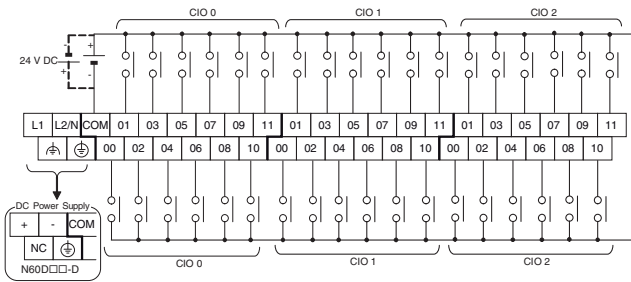

● Transistor Outputs (Sinking)

CP1E-N60S(1)DT-D

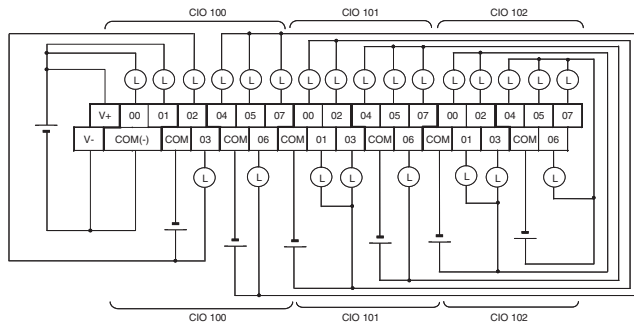

● Transistor Outputs (Sourcing)

CP1E-N60S(1)DT1-D

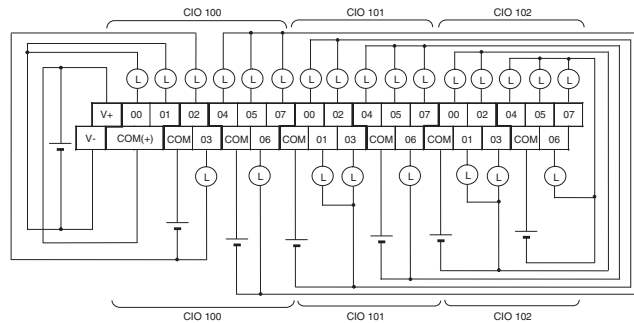

Output Wiring Diagram

● Relay Outputs

CP1E-N60DR-□□/□60SDR-A

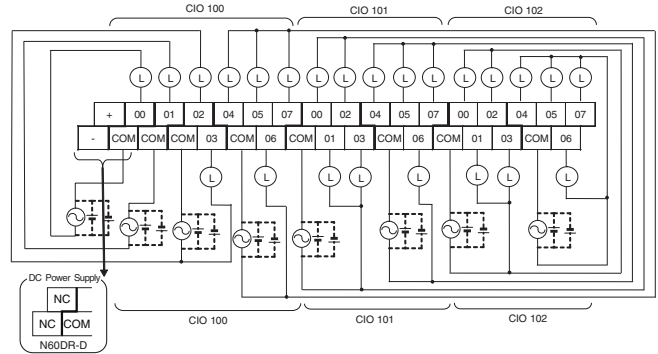

CP1E-N60DT-□

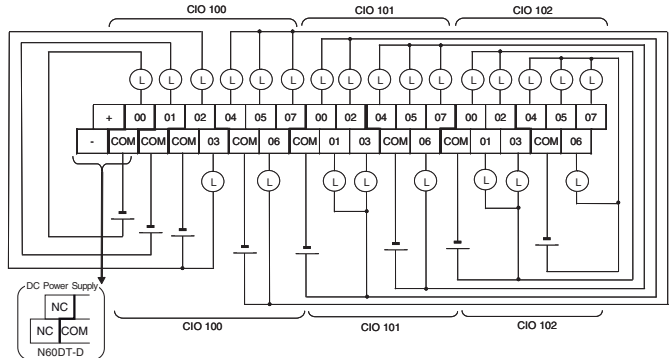

CP1E-N60DT1-□

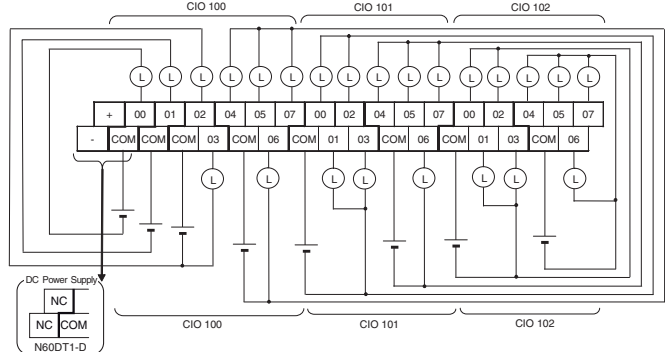

CPU Units with Built-in Analog and 20 I/O Points (Terminal Block is not removable)

Input Wiring Diagram

● **All Models**

- AC Power Supply
- CP1E-NA20D□□-A
- DC Power Supply
- CP1E-NA20D□□-D

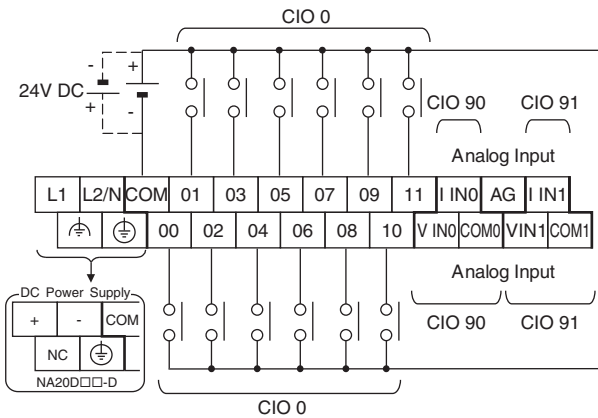

Output Wiring Diagram

● **Relay Outputs**

CP1E-NA20DR-A

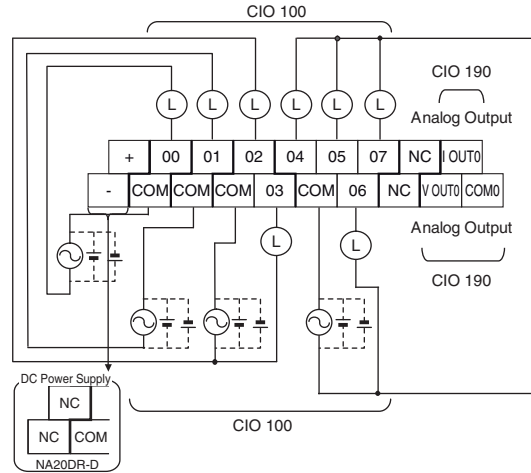

● **Transistor Outputs (Sinking)**

CP1E-NA20DT-D

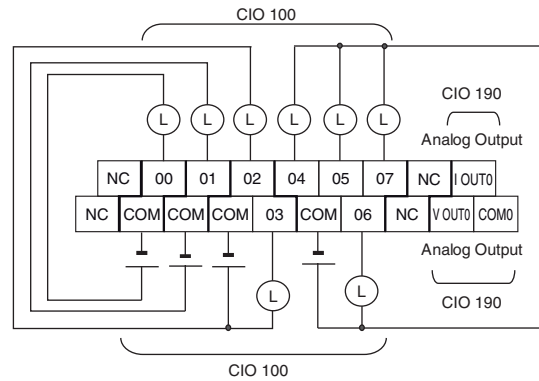

● **Transistor Outputs (Sourcing)**

CP1E-NA20DT1-D

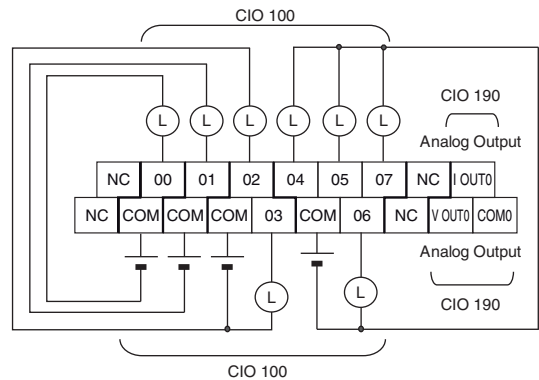

Analog Input Wiring Diagram | **Analog Output Wiring Diagram**

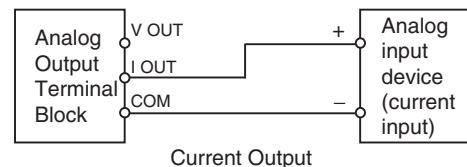
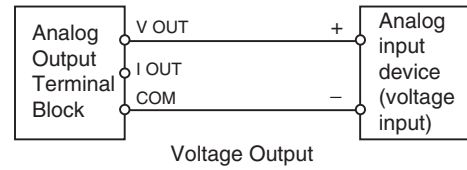
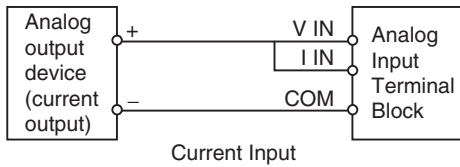
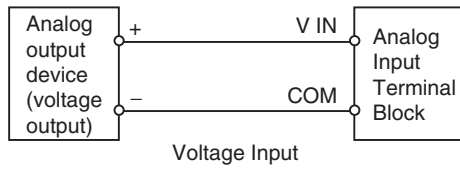

VIN0	Analog input 0 voltage input
IIN0	Analog input 0 current input
COM0	Analog input 0 common
AG	Analog 0V
VIN1	Analog input 1 voltage input
IIN1	Analog input 1 current input
COM1	Analog input 1 common

VOUT0	Analog output 0 voltage output
IOUT0	Analog output 0 current output
COM0	Analog output 0 common

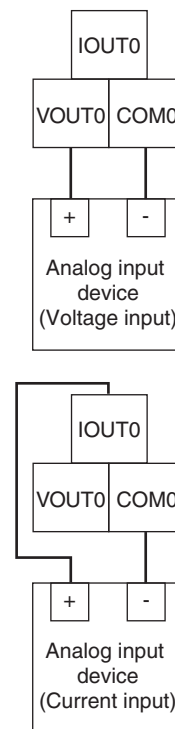
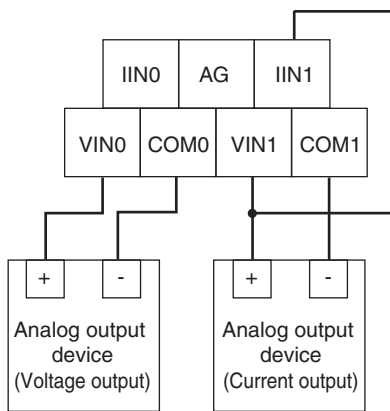

- Note 1** Use 2-conductor shielded twisted-pair cable for the I/O wiring, and do not connect the shield AG terminal.
- If an input is not being used, connect (short) the input's + and - terminals.
 - Wire I/O lines apart from power lines (AC power supply lines, three-phase power lines, etc.).
 - If noise is received from power supply lines, insert a noise filter in the power supply input section.
 - When noise disturbs the analog input/output cable, install the core to improve anti-noise performance.

Input Wiring Example When Using External Power Supply

AC-power-supply E30/40/60(S), N30/40/60(S□) or NA20 CPU Units have an external power supply (DC24V 0.3A), and can be used as a service power supply for input devices.

DC-power-supply E10/14/20(S) or N14/20 CPU Units have no external power supply.

Wiring Example: AC-power-supply CPU Units with 40 I/O Points

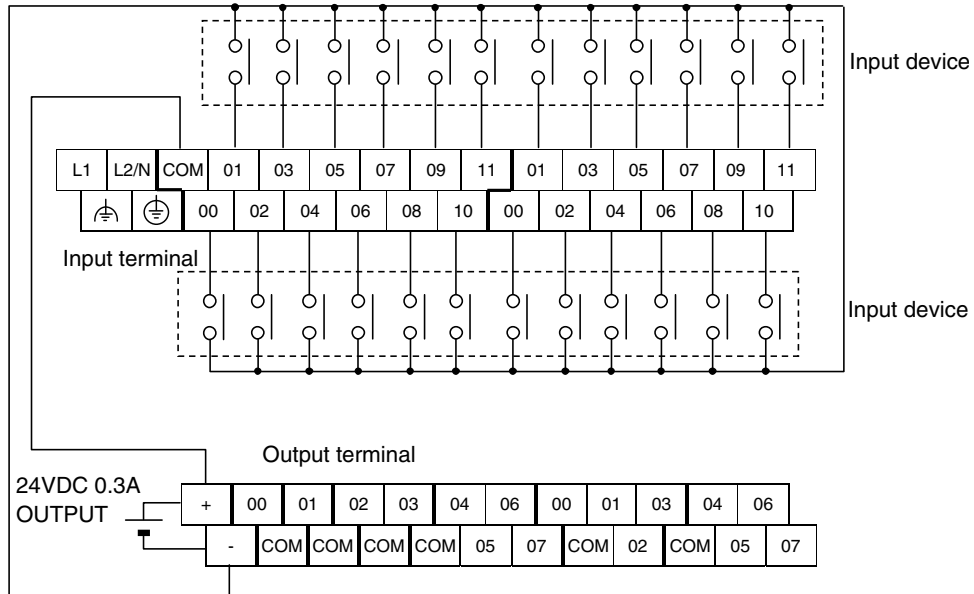

A-2-2 Expansion I/O Units

The first input word allocated to the Expansion I/O Unit is shown as CIO m and the first output word is shown as CIO n.

8-point Input Unit (Terminal Block is not removable)

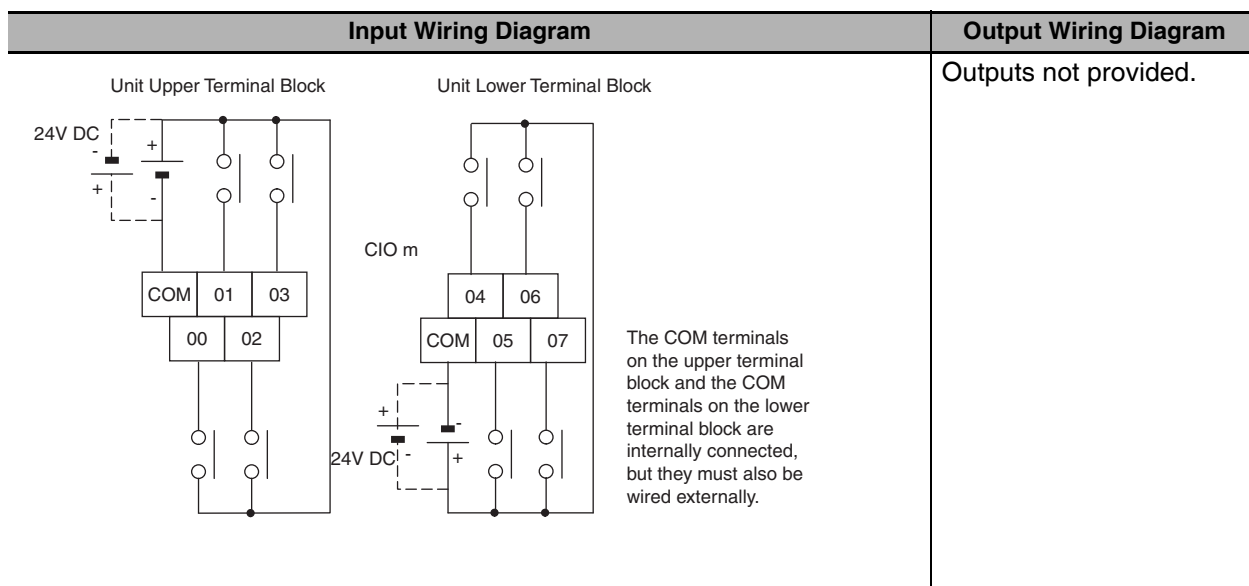

8-point Output Units (Terminal Block is not removable)

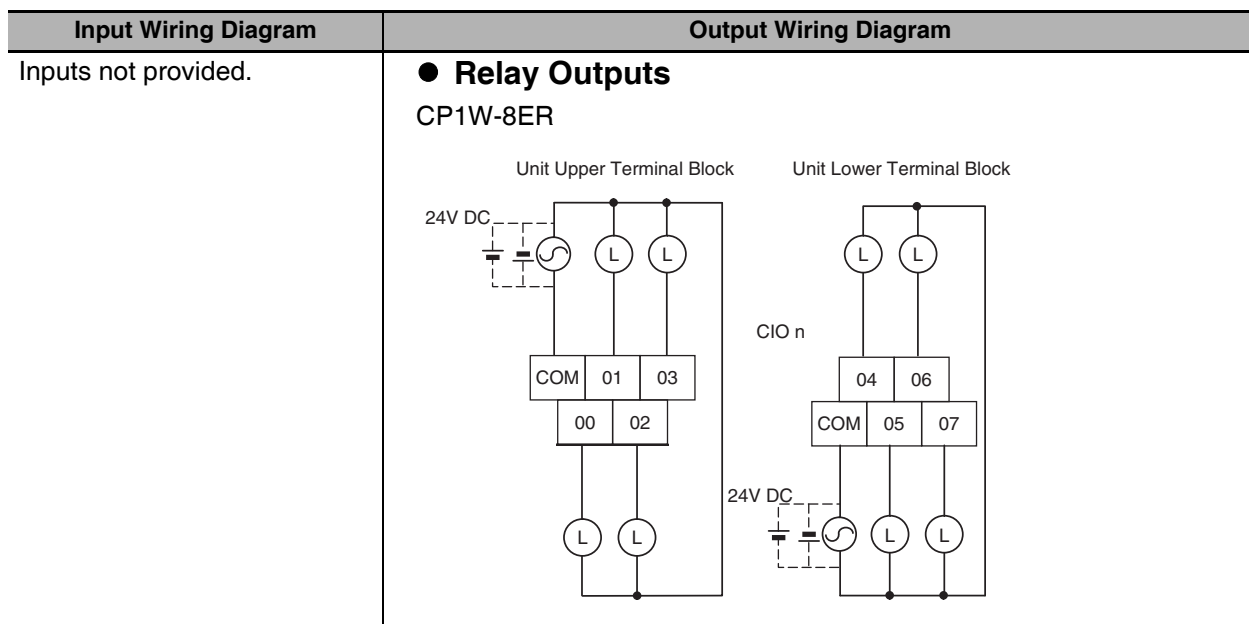

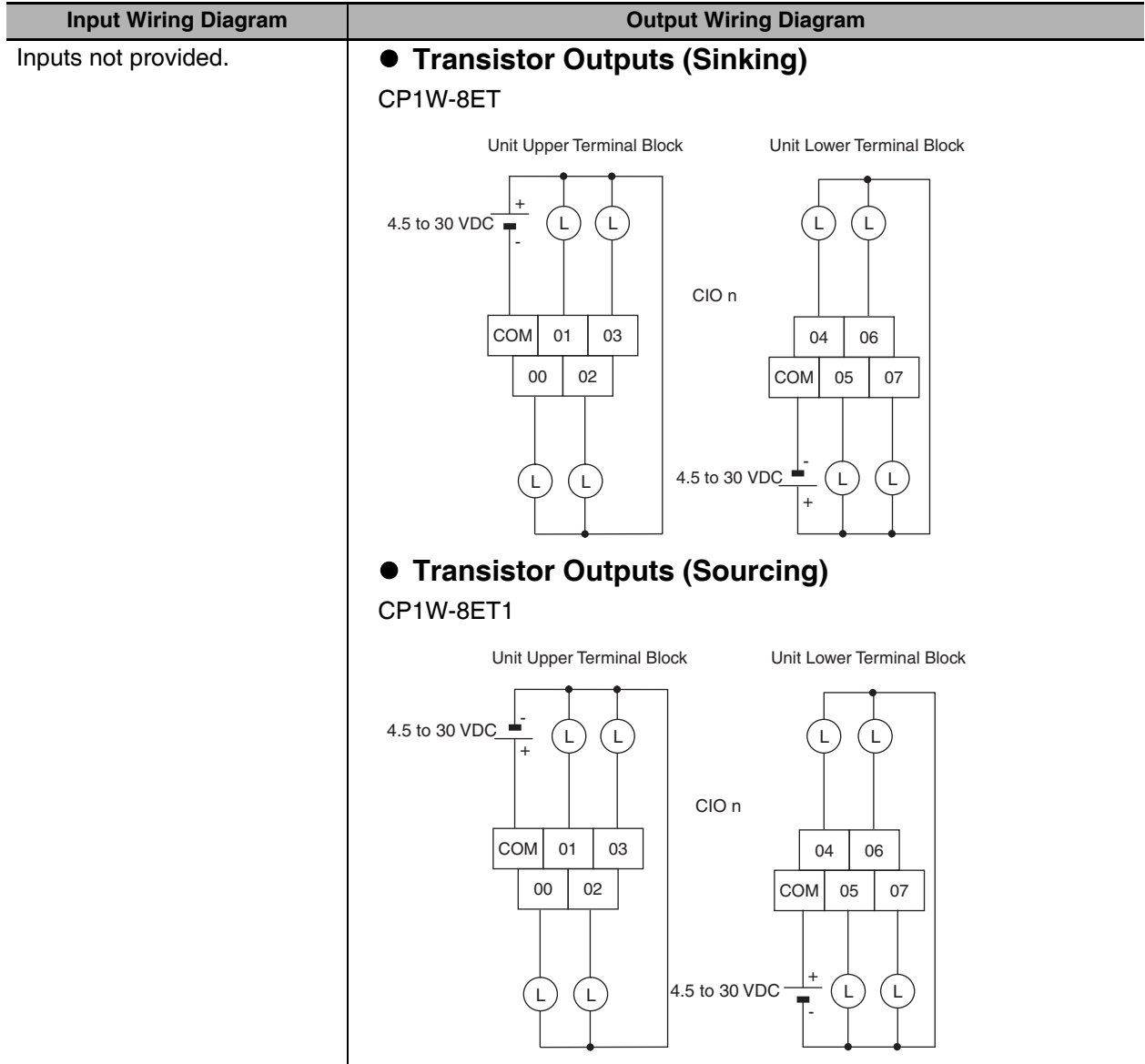

16-point Output Units (Terminal Block is not removable)

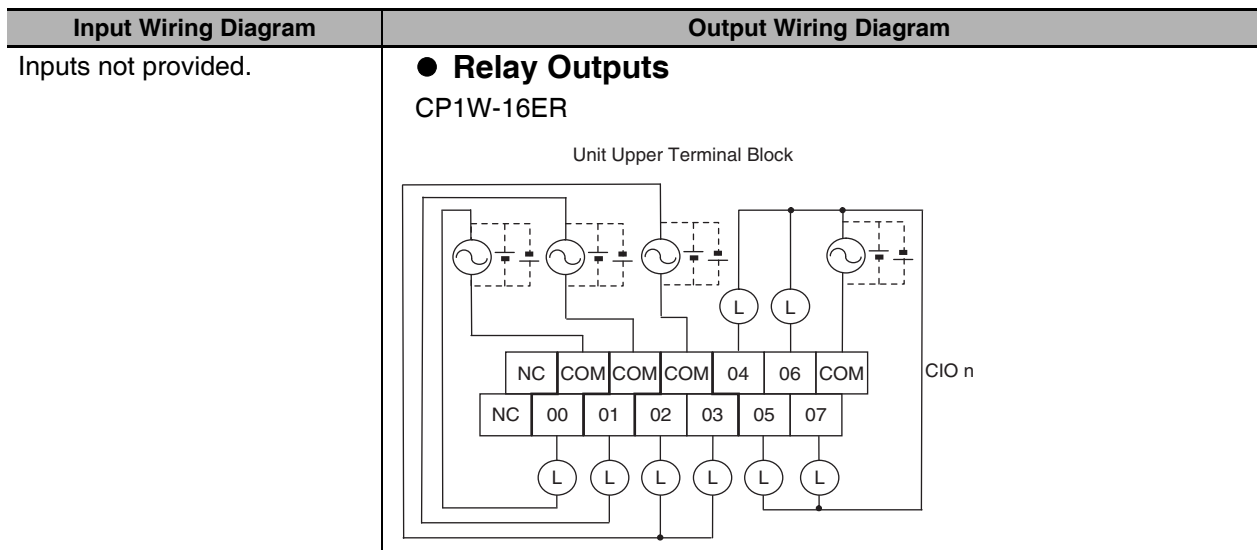

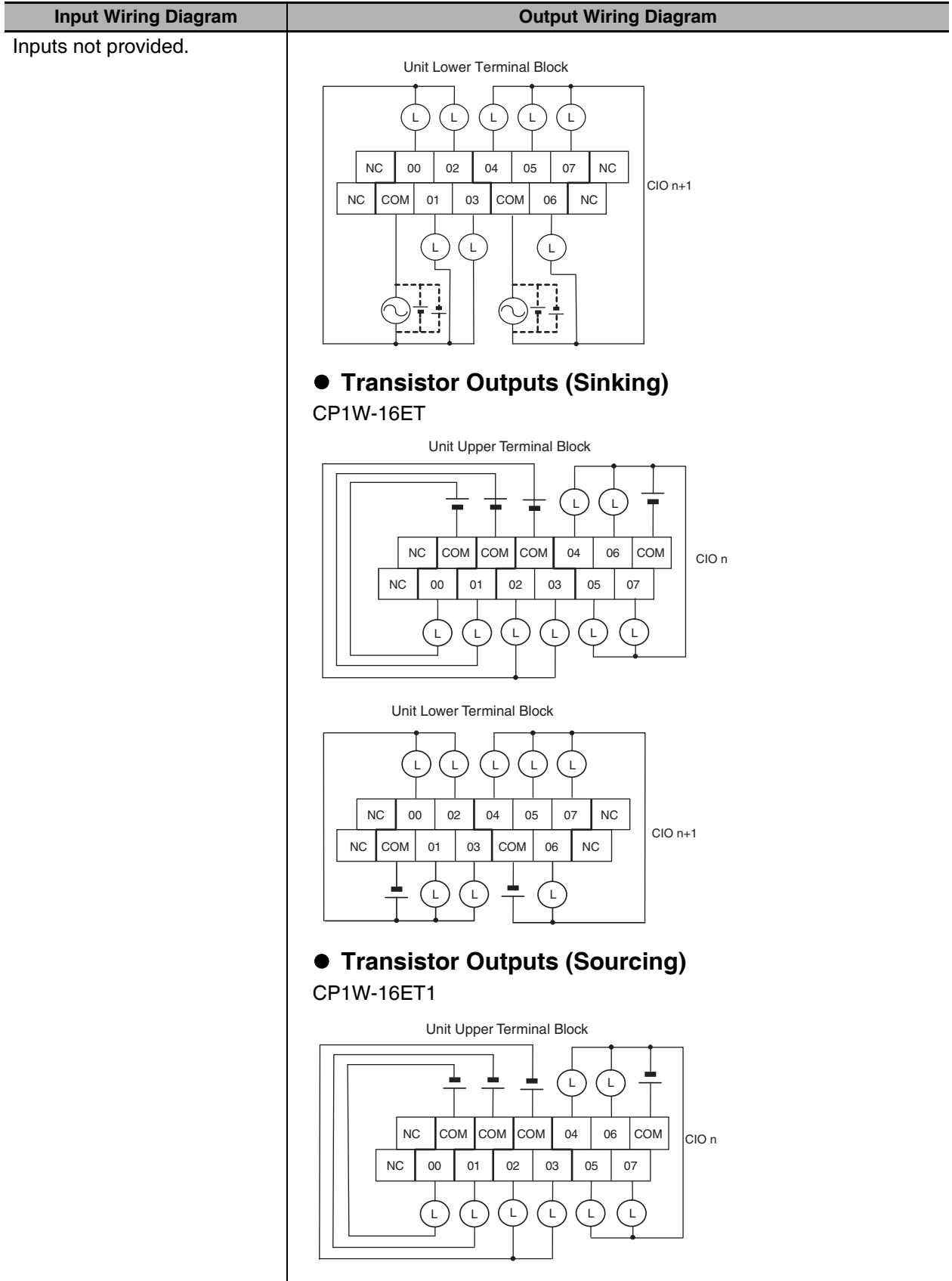

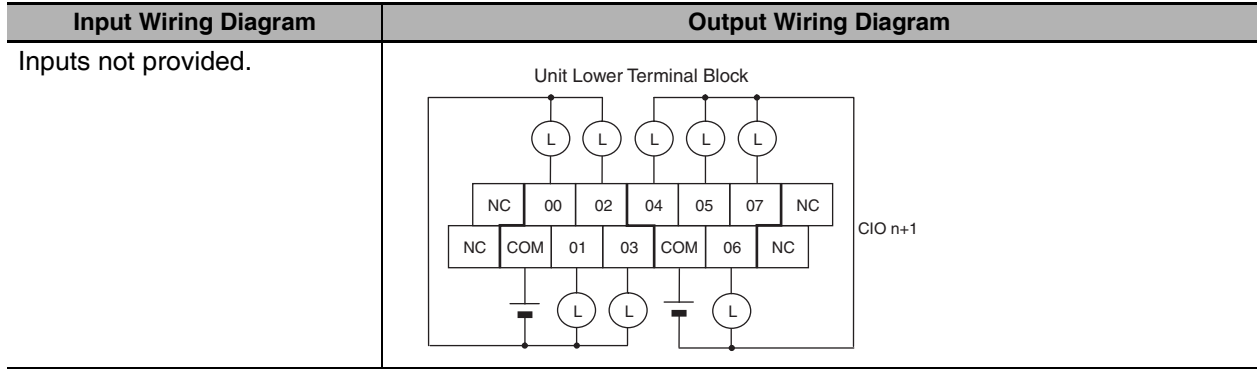

32-point Output Units (Terminal Block is not removable)

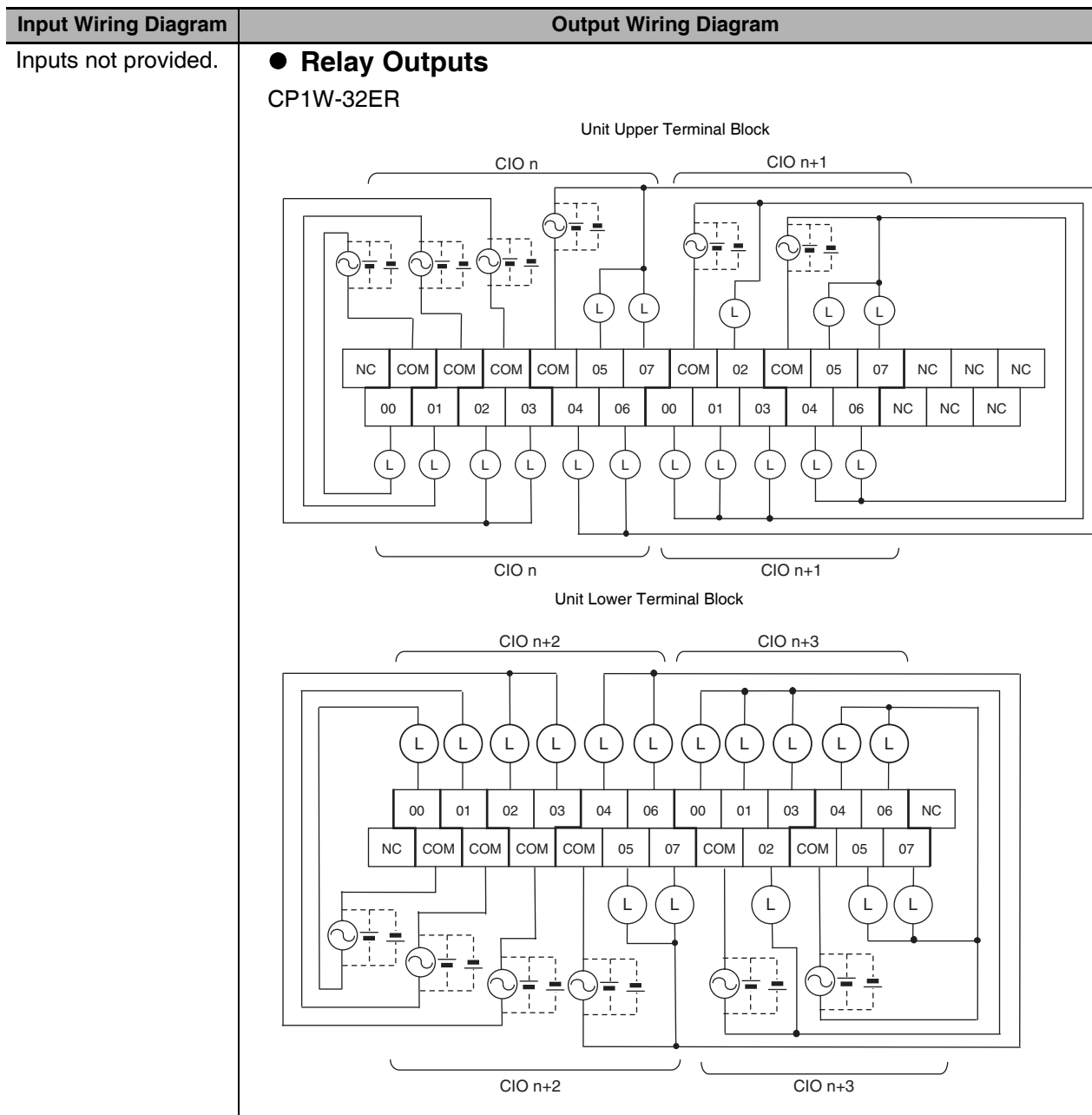

Input Wiring Diagram | **Output Wiring Diagram**

Inputs not provided.

● **Transistor Outputs (Sinking)**

CP1W-32ET

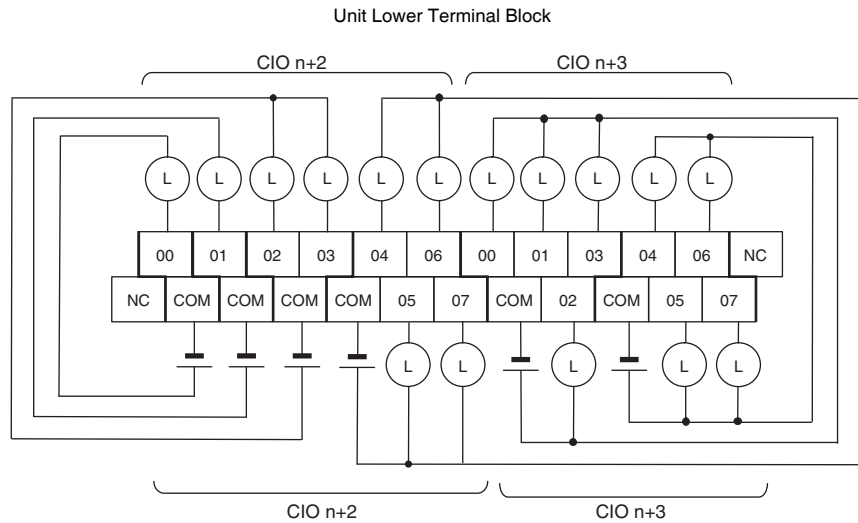
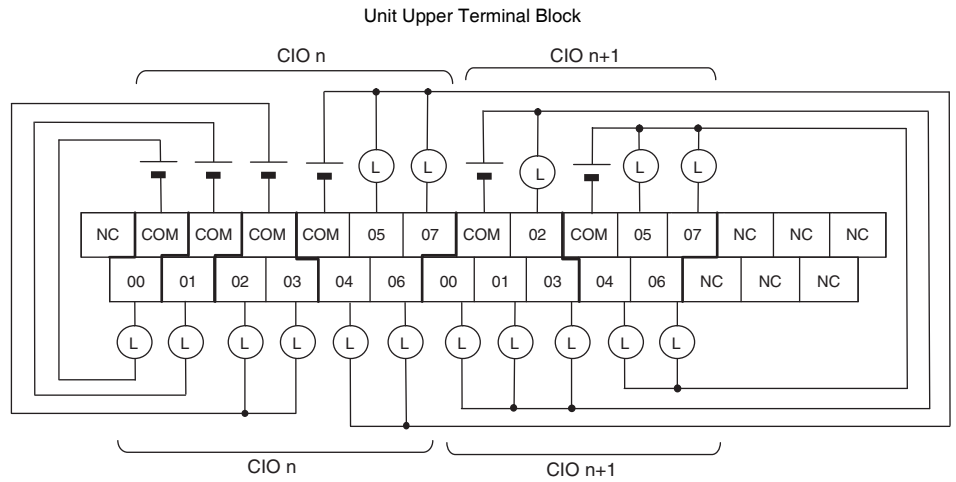

● **Transistor Outputs (Sourcing)**

CP1W-32ET1

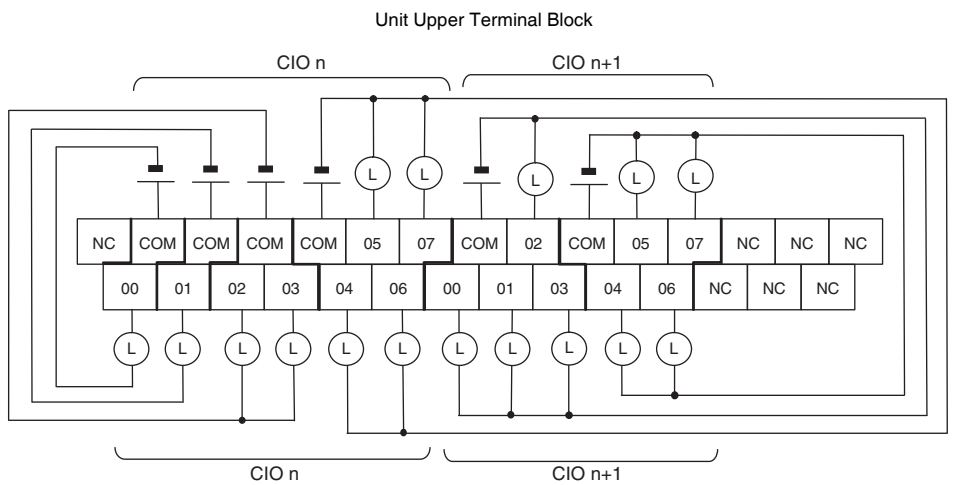

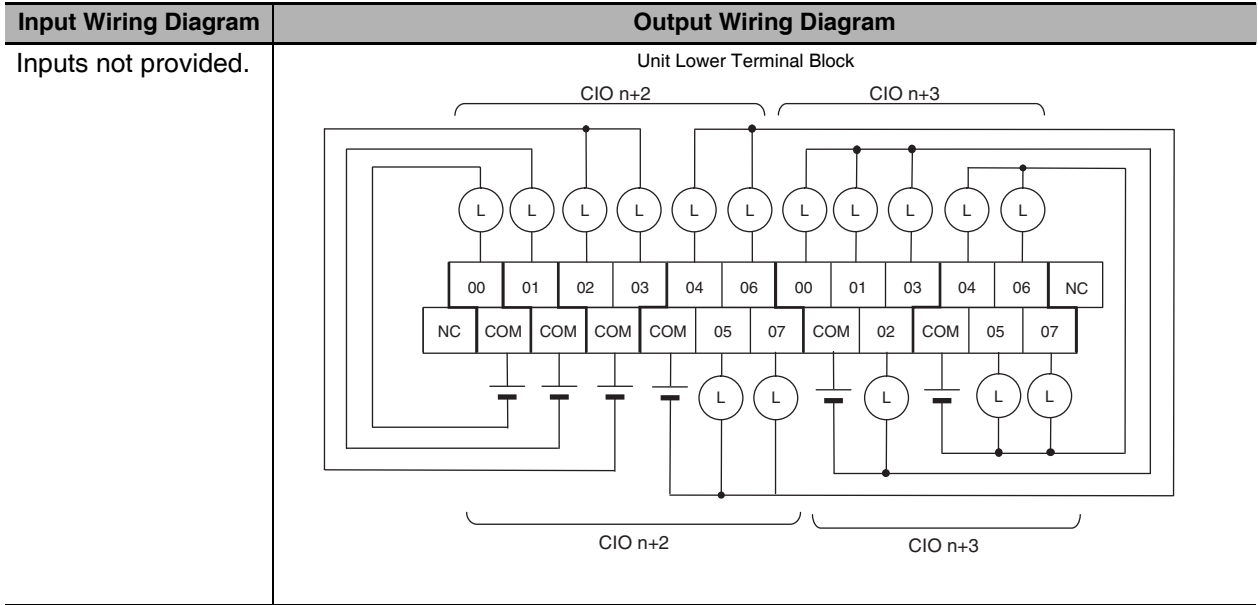

20-point I/O Units (Terminal Block is not removable)

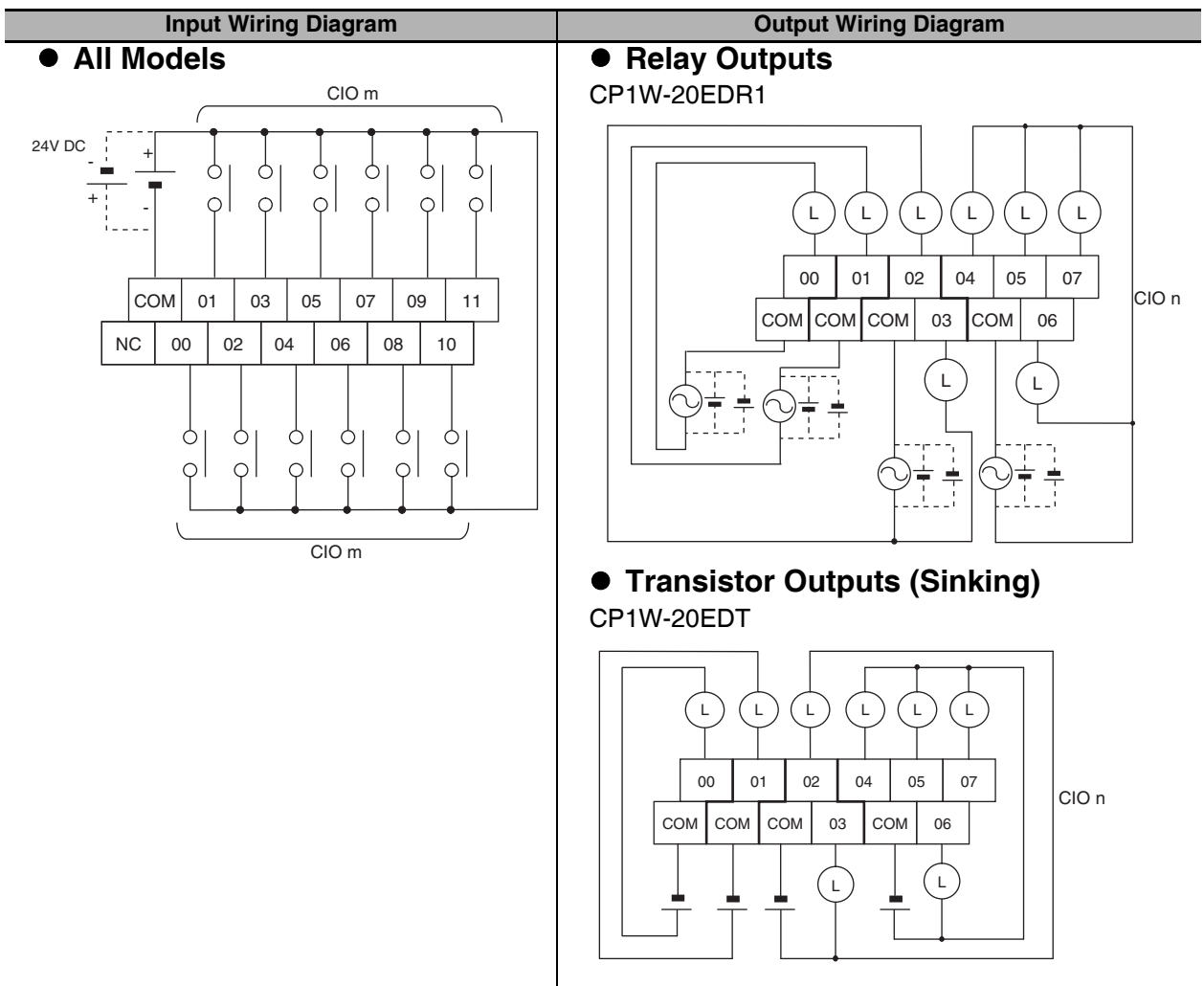

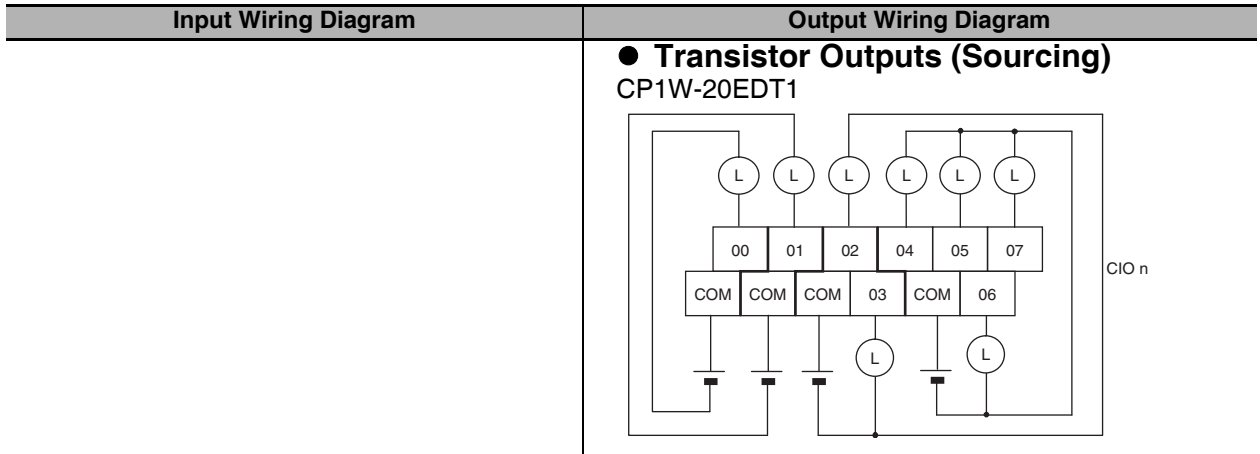

40-point I/O Units (Terminal Block is not removable)

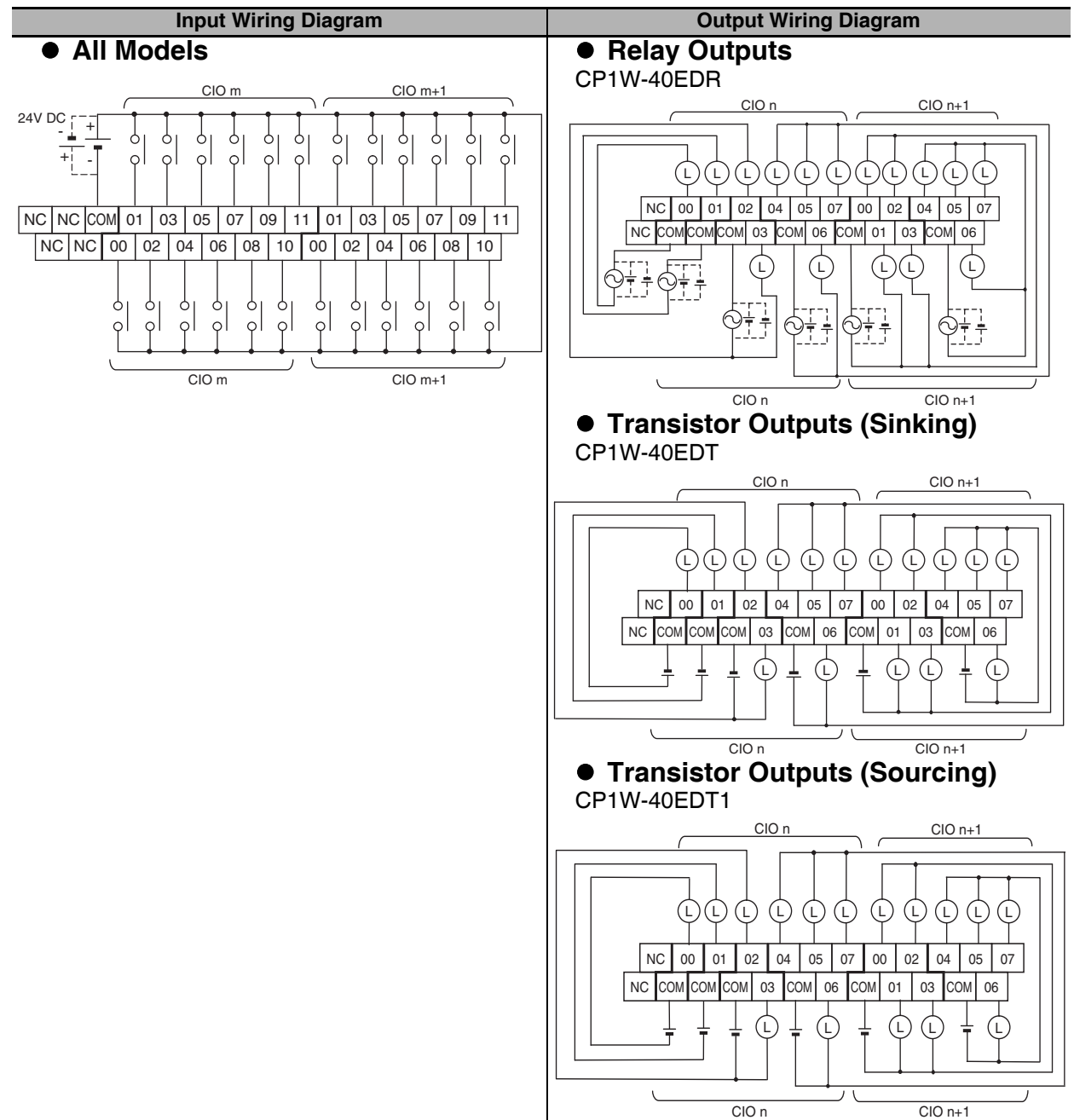

A-2-3 Expansion Units

CP1W-AD041/AD042 Analog Input Unit (Terminal Block is not removable)

Wiring Diagrams

● Input Terminal Arrangement

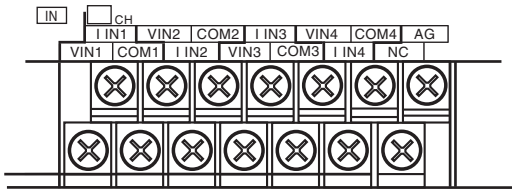

V IN1	Voltage input 1
I IN1	Current input 1
COM1	Input common 1
V IN2	Voltage input 2
I IN2	Current input 2
COM2	Input common 2
V IN3	Voltage input 3
I IN3	Current input 3
COM3	Input common 3
V IN4	Voltage input 4
I IN4	Current input 4
COM4	Input common 4

Note For current inputs, short V IN1 to I IN1, V IN2 to I IN2, V IN3 to I IN3, and V IN4 to I IN4.

● Wiring Methods

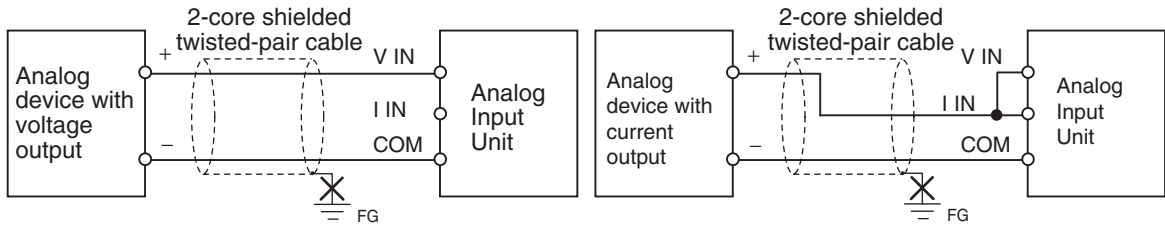

Example:

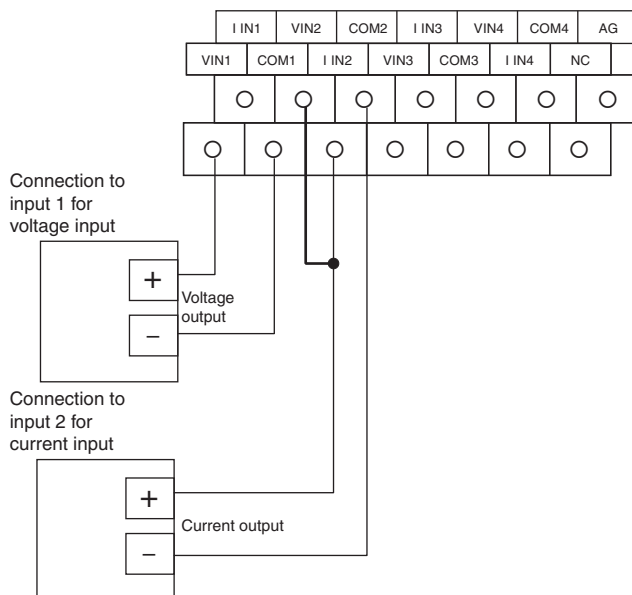

CP1W-DA021 Analog Output Unit (Terminal Block is not removable)

Wiring Diagrams

● Output Terminal Arrangement

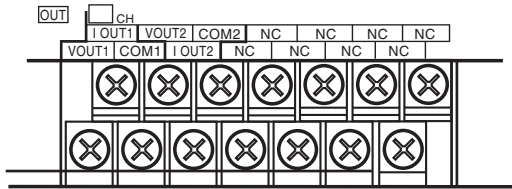

V OUT1	Voltage output 1
I OUT1	Current output 1
COM1	Output common 1
V OUT2	Voltage output 2
I OUT2	Current output 2
COM2	Output common 2

● Wiring Methods

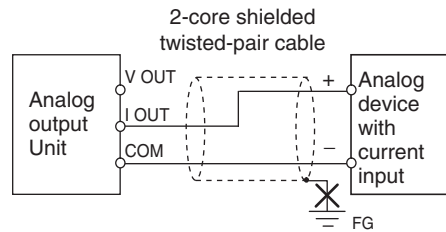
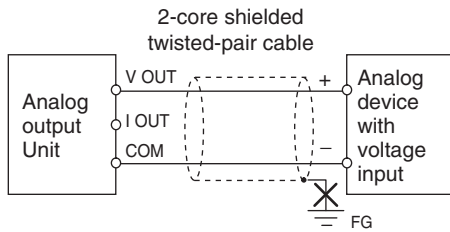

Example:

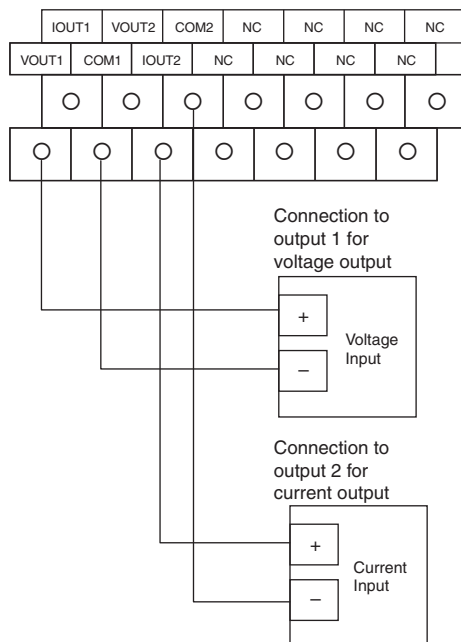

CP1W-DA041/DA042 Analog Output Unit (Terminal Block is not removable)

Wiring Diagrams

● Output Terminal Arrangement

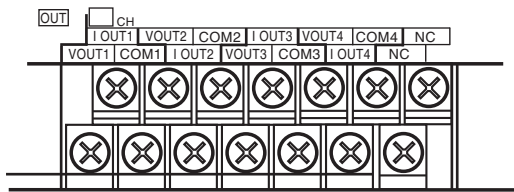

V OUT1	Voltage output 1
I OUT1	Current output 1
COM1	Output common 1
V OUT2	Voltage output 2
I OUT2	Current output 2
COM2	Output common 2
V OUT3	Voltage output 3
I OUT3	Current output 3
COM3	Output common 3
V OUT4	Voltage output 4
I OUT4	Current output 4
COM4	Output common 4

● Wiring Methods

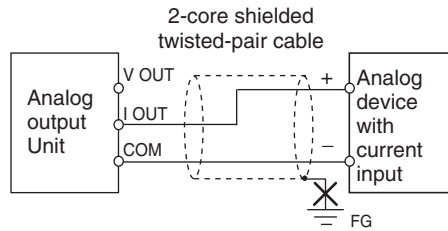
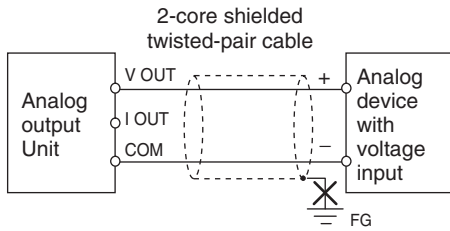

Example:

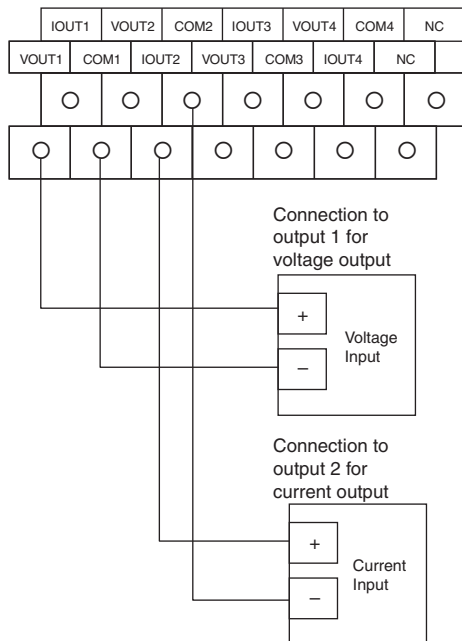

CP1W-MAD11 Analog I/O Unit (Terminal Block is not removable)

Wiring Diagrams

I/O Terminal Arrangement

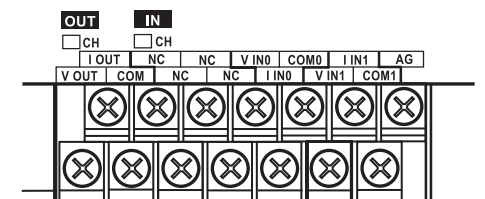

V OUT	Voltage output
I OUT	Current output
COM	Output common
V IN0	Voltage input 0
I IN0	Current input 0
COM0	Input common 0
V IN1	Voltage input 1
I IN1	Current input 1
COM1	Input common 1

Note For current inputs, short V IN0 to I IN0 and V IN1 to I IN1.

Wiring Methods

Wiring Analog Inputs

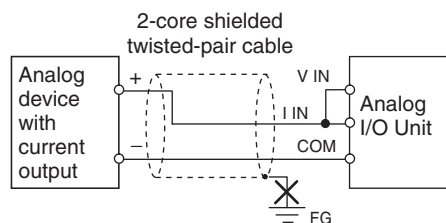
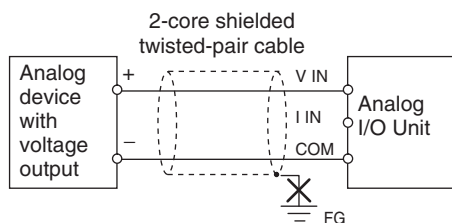

Wiring Analog Outputs

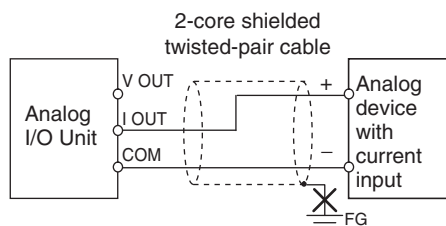
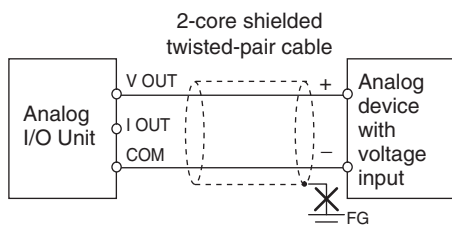

Wiring Diagrams

Example:

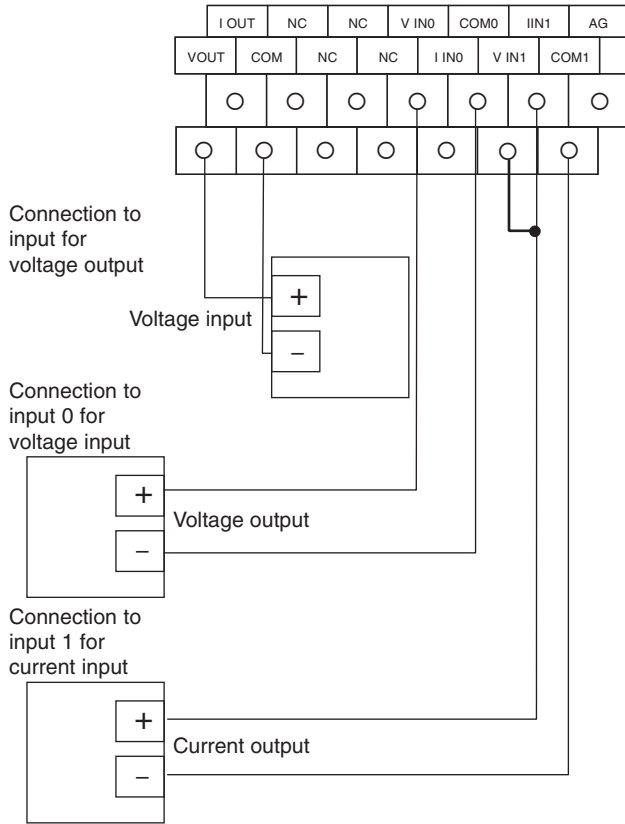

CP1W-MAD42 Analog I/O Unit (Terminal Block is not removable)

Wiring Diagrams

● I/O Terminal Arrangement

- Input Terminal Arrangement

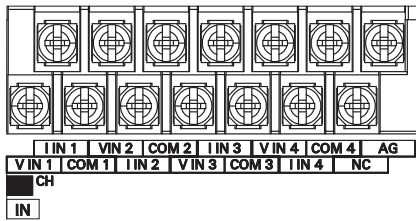

V IN1	Voltage input 1
I IN1	Current input 1
COM1	Input common 1
V IN2	Voltage input 2
I IN2	Current input 2
COM2	Input common 2
V IN3	Voltage input 3
I IN3	Current input 3
COM3	Input common 3
V IN4	Voltage input 4
I IN4	Current input 4
COM4	Input common 4

Note For current inputs, short V IN1 to I IN1, V IN2 to I IN2, V IN3 to I IN3, and V IN4 to I IN4.

- Output Terminal Arrangement

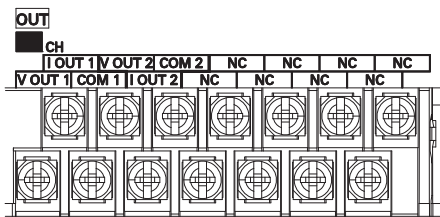

V OUT1	Voltage output 1
I OUT1	Current output 1
COM1	Output common 1
V OUT2	Voltage output 2
I OUT2	Current output 2
COM2	Output common 2

● Wiring Methods

- Wiring Analog Inputs

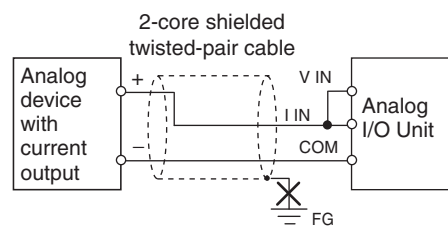
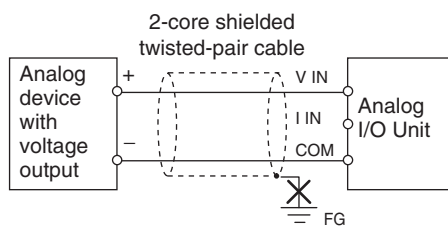

- Wiring Analog Outputs

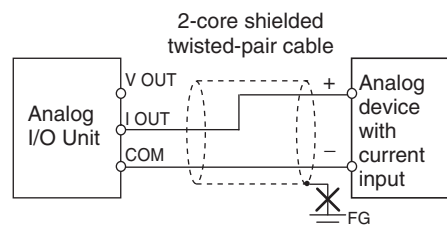
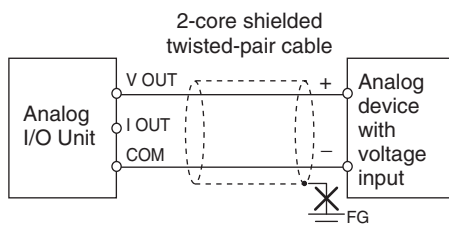

CP1W-MAD44 Analog I/O Unit (Terminal Block is not removable)

Wiring Diagrams

I/O Terminal Arrangement

- Input Terminal Arrangement

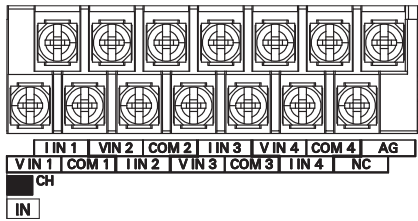

V IN1	Voltage input 1
I IN1	Current input 1
COM1	Input common 1
V IN2	Voltage input 2
I IN2	Current input 2
COM2	Input common 2
V IN3	Voltage input 3
I IN3	Current input 3
COM3	Input common 3
V IN4	Voltage input 4
I IN4	Current input 4
COM4	Input common 4

Note For current inputs, short V IN1 to I IN1, V IN2 to I IN2, V IN3 to I IN3, and V IN4 to I IN4.

- Output Terminal Arrangement

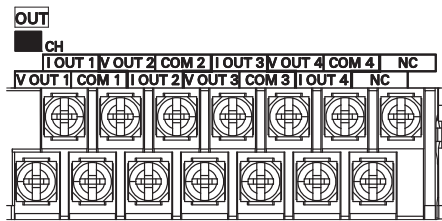

V OUT1	Voltage output 1
I OUT1	Current output 1
COM1	Output common 1
V OUT2	Voltage output 2
I OUT2	Current output 2
COM2	Output common 2
V OUT3	Voltage output 3
I OUT3	Current output 3
COM3	Output common 3
V OUT4	Voltage output 4
I OUT4	Current output 4
COM4	Output common 4

Wiring Methods

- Wiring Analog Inputs

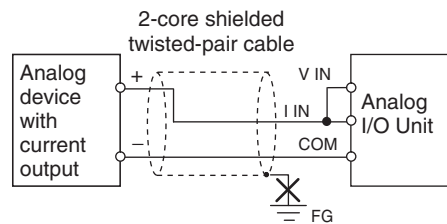
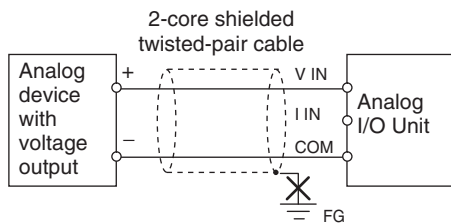

- Wiring Analog Outputs

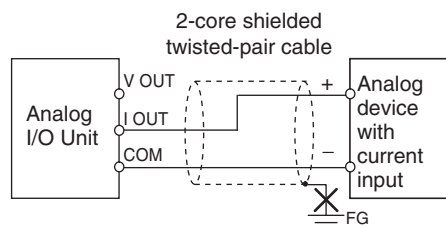
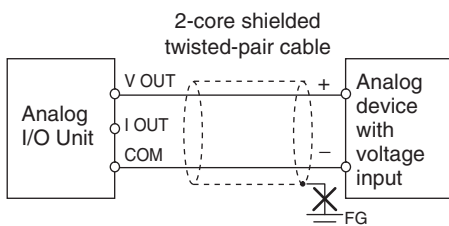

CP1W-TS001/TS002/TS101/TS102 Temperature Sensor Units (Terminal Block is not removable)

Wiring Diagrams

● Connecting a Thermocouple

- CP1W-TS001

One or two K or J thermocouples can be connected to the CP1W-TS001.

Both of the thermocouples must be of the same type and the same input range must be used for each.

Example:

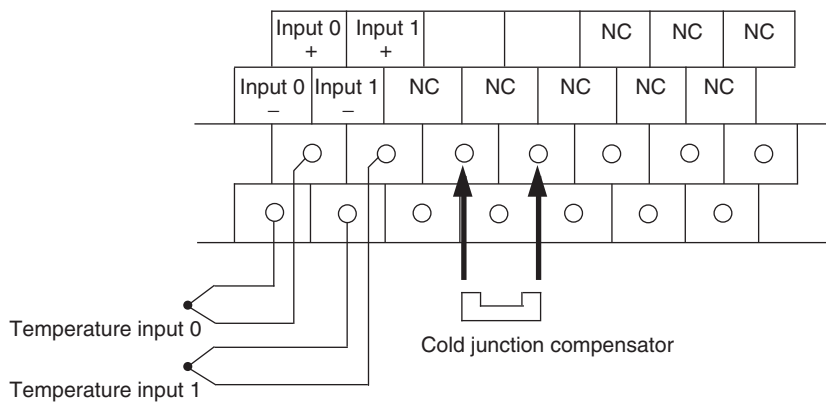

- CP1W-TS002

One to four K or J thermocouples can be connected to the CP1W-TS002.

All of the thermocouples must be of the same type and the same input range must be used for each.

Example:

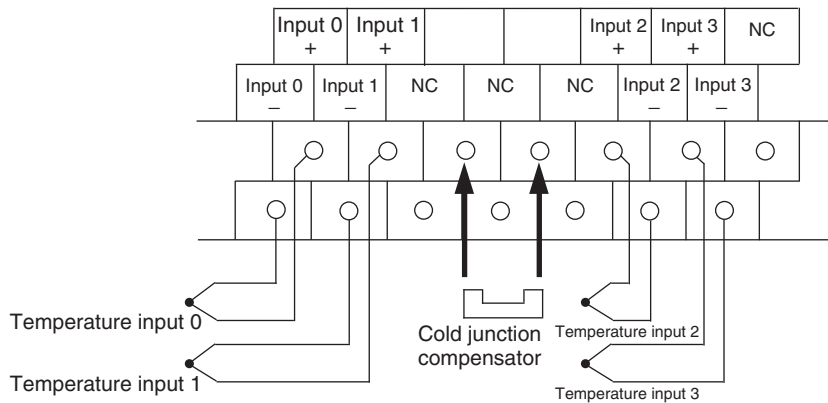

Wiring Diagrams

● **Connecting a Platinum Resistance Thermometer**

• CP1W-TS101

One or two Pt or JPt platinum resistance thermometers can be connected to the CP1W-TS101. Both of the thermometers must be of the same type and the same input range must be used for each.

Example:

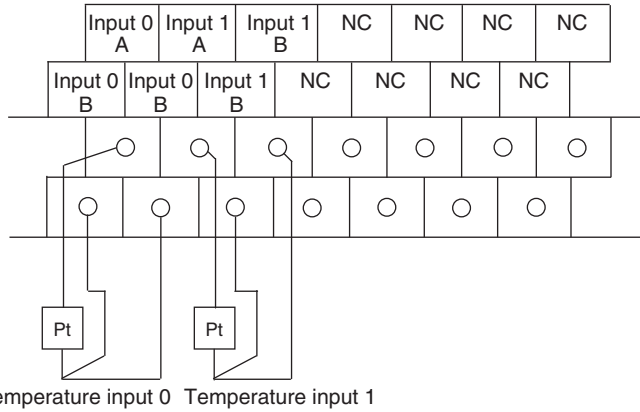

• CP1W-TS102

One to four Pt or JPt platinum resistance thermometers can be connected to the CP1W-TS102. All of the thermometers must be of the same type and the same input range must be used for each.

Example:

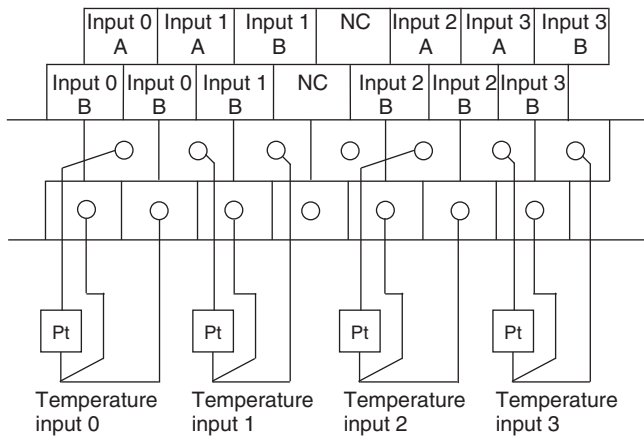

CP1W-TS003 Temperature Sensor Units (Terminal Block is not removable)

Wiring Diagrams

● Connecting a Thermocouple

Either K or J thermocouples can be connected, but all four of the thermocouples must be of the same type and the same input range must be used for each. Only last two channels can be used as analog inputs.

Example:

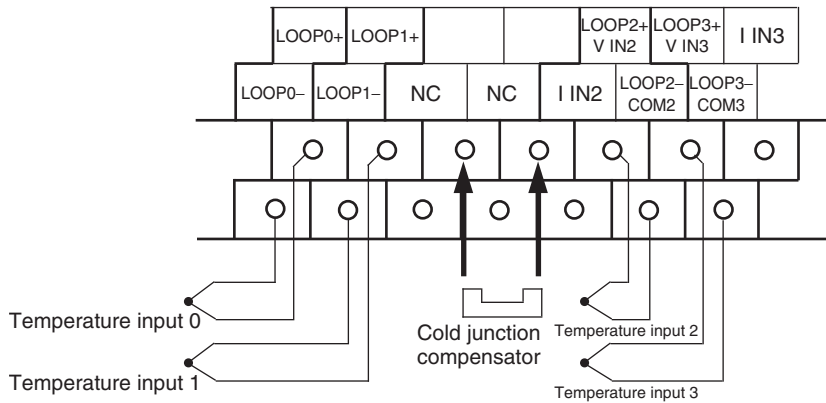

● Connecting Analog Inputs

Only last two channels can be used as analog inputs.

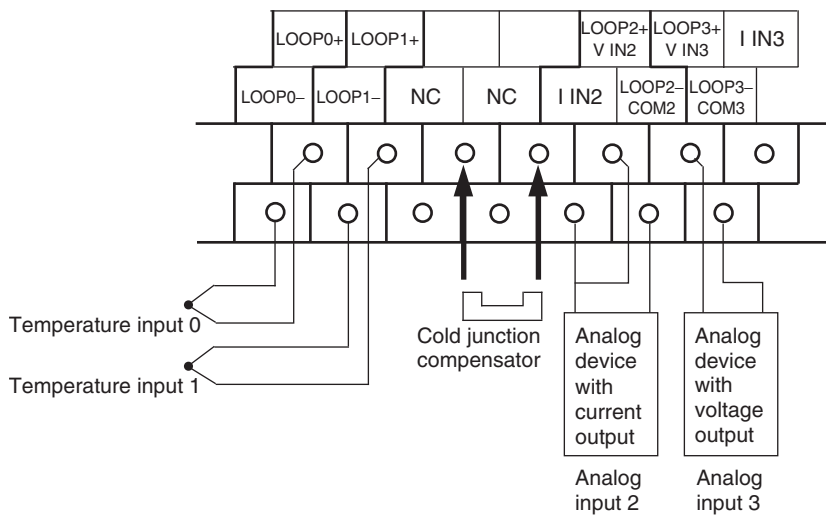

CP1W-TS004 Temperature Sensor Units (Terminal Block is not removable)

Wiring Diagrams

● Connecting a Thermocouple

Either K or J thermocouples can be connected, but all twelve of the thermocouples must be of the same type and the same input range must be used for each.

Example:

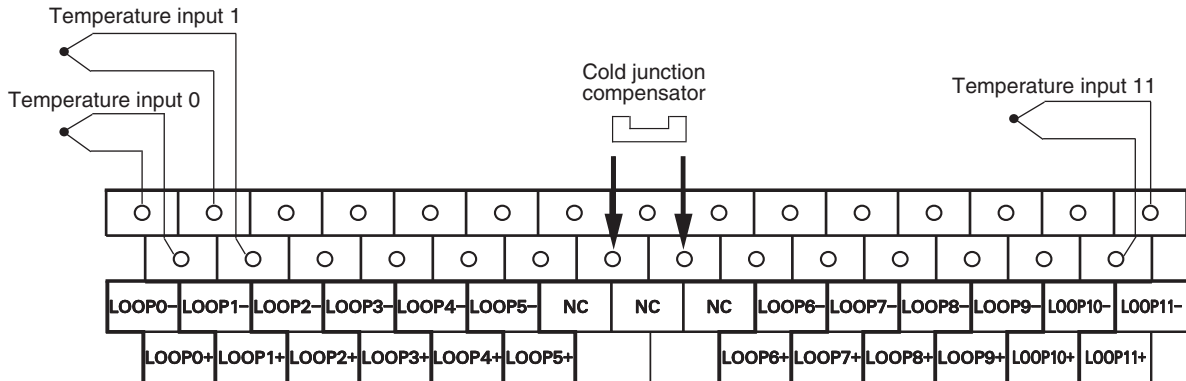

CP1W-SRT21 CompoBus/S I/O Link Unit (Terminal Block is not removable)

Wiring Diagrams

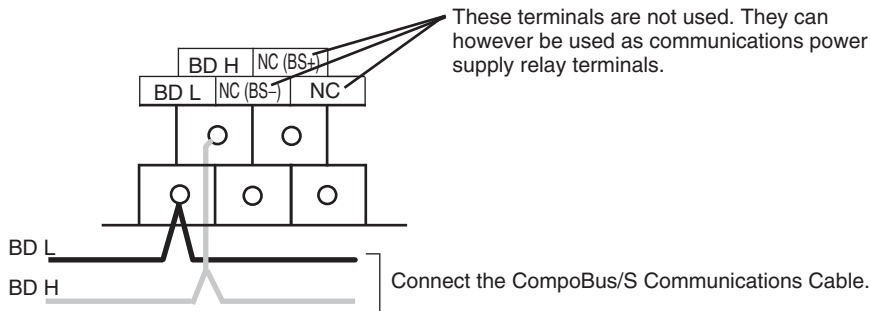

A-2-4 Serial Communications

Wiring Examples for PTs Using NT Link

● Connecting a PT and a PLC 1:1 with RS-232C Ports

- Communications Mode: 1:N NT Link, N = 1 only
- OMRON Cables with Connectors: XW2Z-200T (2 m)
XW2Z-500T (5 m)

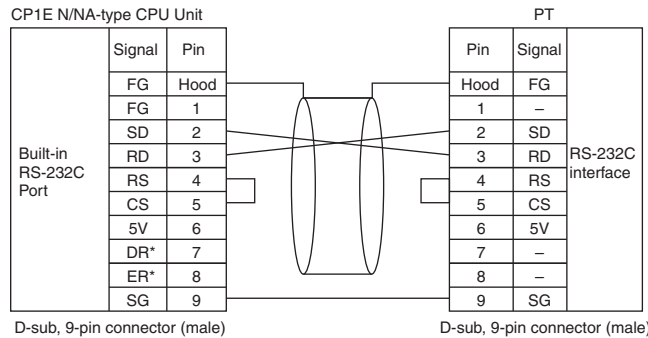

* DR and ER signals are not supported by the N□□S(1)-type CPU Unit.

● Connecting a PT and a PLC with 1:N NT Link and RS-422A/485 Ports Using 4-wire, RS-422A Communications

- Communications mode: 1:N NT Link, N = 1 only

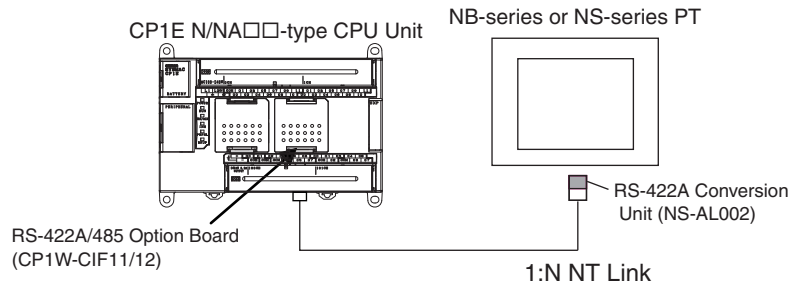

Note Do not use NS-AL002, when connecting the built-in RS-422A port of the NB-series PT.

● Wiring Example

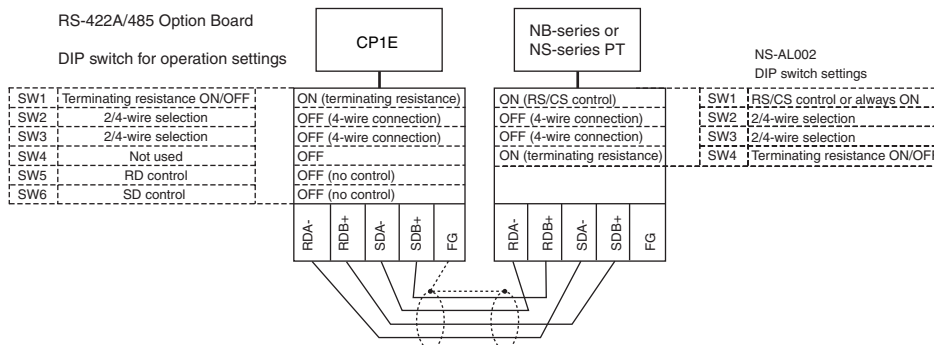

Note Do not use NS-AL002, when connecting the built-in RS-422A port of the NB-series PT.

No-protocol Communications

● Connecting RS-232C Ports 1:1

- Communications Mode: No-protocol

Example: Connections to E5CK Controller

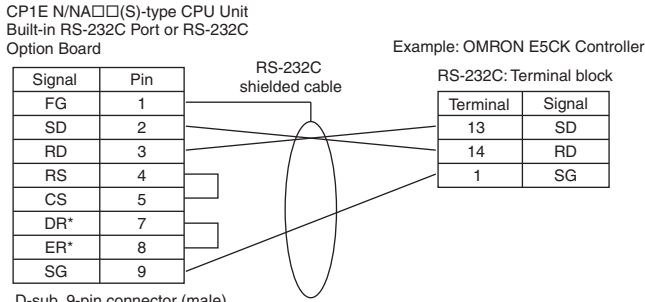

- * DR and ER signals are not supported by the N□□S(1)-type CPU Unit.

● Connecting RS-422A/485 Ports 1:1 with 2-wire Connections

- Communications Mode: No-protocol

N/NA□□-type CPU Unit

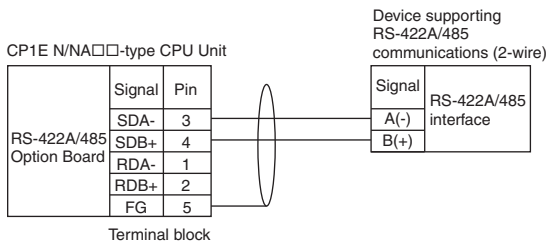

N□□S1-type CPU Unit

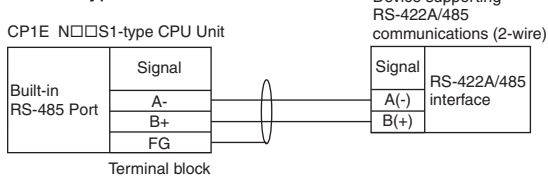

● Connecting RS-422A/485 Ports 1:1 with 4-wire Connections

- Communications Mode: No-protocol

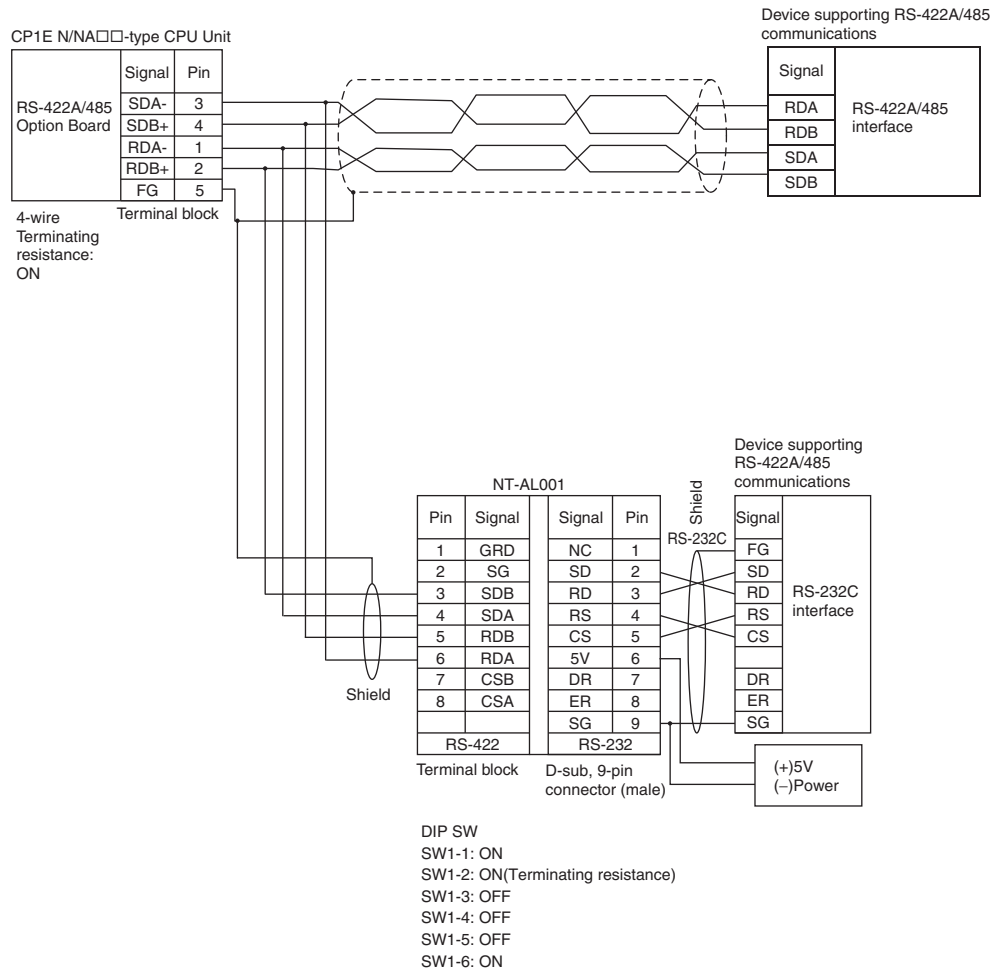

Modbus-RTU Easy Master Function

- Communications mode: Modbus-RTU Easy Master

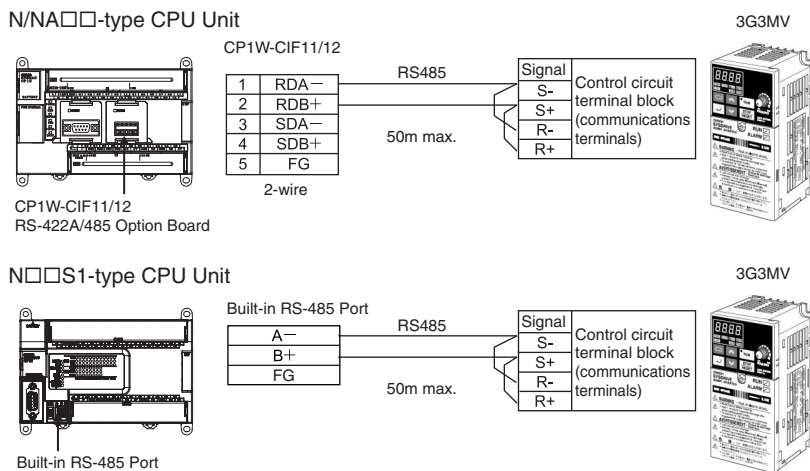

Serial PLC Links

- Communications mode: Serial PLC Link (Master) or Serial PLC Link (Slave)

● Connection with RS-232C Ports

RS-232C connection is also possible when using a Serial PLC Link to connect two CP1E N/NA□□(S)□-type CPU Units.

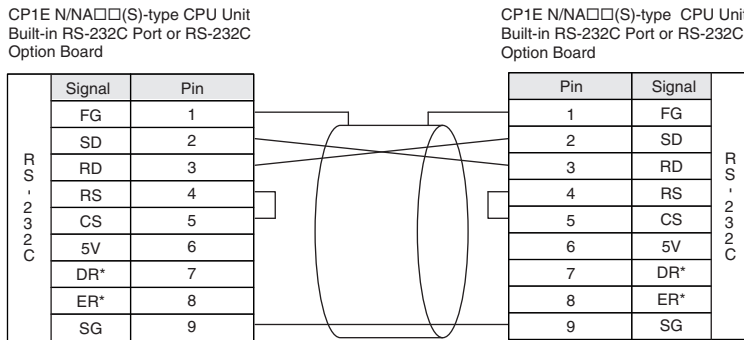

* DR and ER signals are not supported by the N□□S(1)-type CPU Unit.

• Wiring Example Using RS-422A/485 Ports with RS-422A, 4-wire Connections

CP1E N/NA□□-type CPU Unit
Built-in RS-232C port
CJ1W-CIF11 RS-422A Conversion Unit

DIP SW
SW1: ON (with terminating resistance)
SW2: OFF (4-wire connection)
SW3: OFF (4-wire connection)
SW4: OFF
SW5: OFF (no RS control for RD)
SW6: OFF (no RS control for SD)

Note CJ1W-CIF11 cannot be connected to the built-in RS-232C port of the CP1E N□□S(1)-type CPU Unit.

CP1E N/NA□□-type CPU Unit (Polled Unit No. 0)
CP1W-CIF11 RS-422A/485 Option Board

DIP SW
SW1: OFF (no terminating resistance)
SW2: OFF (4-wire connection)
SW3: OFF (4-wire connection)
SW4: OFF
SW5: OFF (no RS control for RD)
SW6: ON (with RS control for SD)

CJ1M CPU Unit (Polled Unit No. 1)

CJ1W-CIF11 RS-422A Conversion Unit

DIP SW
SW1: ON (with terminating resistance)
SW2: OFF (4-wire connection)
SW3: OFF (4-wire connection)
SW4: OFF
SW5: OFF (no RS control for RD)
SW6: ON (with RS control for SD)

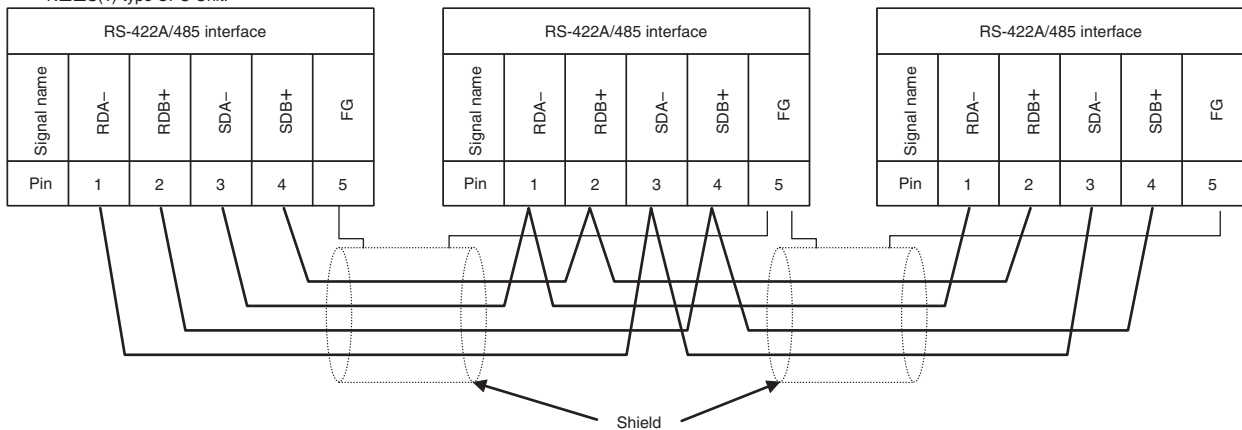

• Wiring Example Using RS-422A/485 Ports with RS-485, 2-wire Connections

CP1E N/NA□□-type CPU Unit
Built-in RS-232C port
CJ1W-CIF11 RS-422A Conversion Unit

DIP SW
SW1: ON (with terminating resistance)
SW2: ON (2-wire connection)
SW3: ON (2-wire connection)
SW4: OFF
SW5: OFF (no RS control for RD)
SW6: ON (with RS control for SD)

Note CJ1W-CIF11 cannot be connected to the built-in RS-232C port of the CP1E □□S(1)-type CPU Unit.

CP1E N/NA□□-type CPU Unit (Polled Unit No. 0)
CP1W-CIF11 RS-422A/485 Option Board

DIP SW
SW1: OFF (no terminating resistance)
SW2: ON (2-wire connection)
SW3: ON (2-wire connection)
SW4: OFF
SW5: OFF (no RS control for RD)
SW6: ON (with RS control for SD)

CJ1M CPU Unit (Polled Unit No. 1)
CJ1W-CIF11 RS-422A Conversion Unit

DIP SW
SW1: ON (with terminating resistance)
SW2: ON (2-wire connection)
SW3: ON (2-wire connection)
SW4: OFF
SW5: OFF (no RS control for RD)
SW6: ON (with RS control for SD)

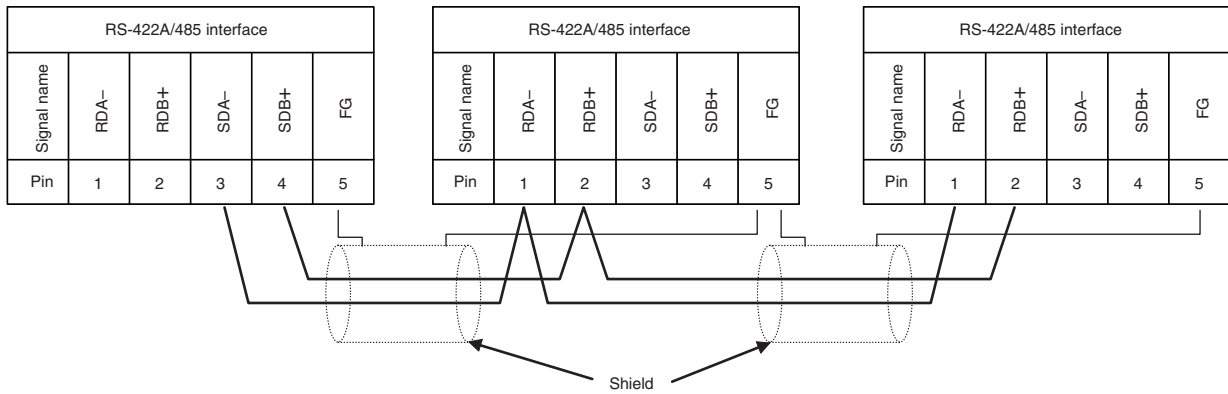

N□□S1-type CPU Unit

CP1E N□□S1-type CPU Unit
Built-in RS-485 port

DIP SW
Terminating resistance : OFF

CP1E N□□S1-type CPU Unit (Polled Unit No. 0)
Built-in RS-485 port

DIP SW
Terminating resistance : OFF

CJ1M CPU Unit (Polled Unit No. 1)

CJ1W-CIF11 RS-422A Conversion Unit

DIP SW
SW1: ON (with terminating resistance)
SW2: ON (2-wire connection)
SW3: ON (2-wire connection)
SW4: OFF
SW5: OFF (no RS control for RD)
SW6: ON (with RS control for SD)

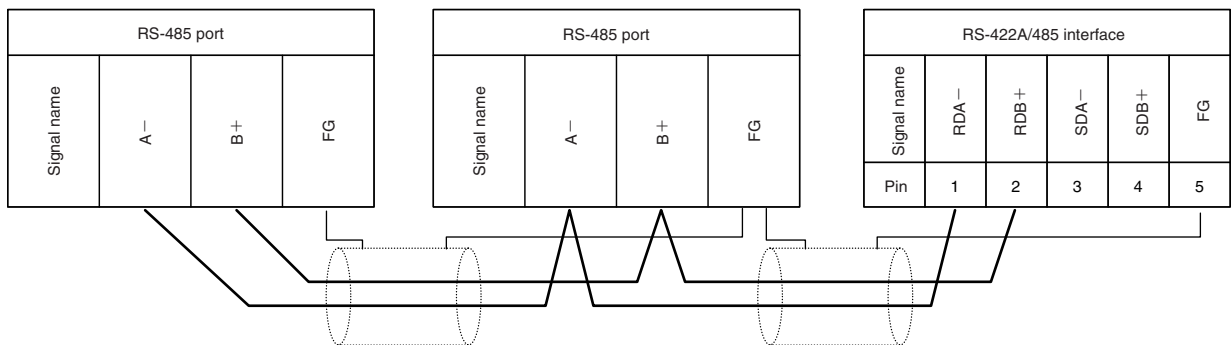

A-3 Wiring for Serial Communications

A-3-1 Recommended RS-232C Wiring

Recommended RS-232C Wiring

We recommend the following wiring method for the RS-232C, especially in environments prone to noise.

1 Use shielded twisted-pair cables for the communications cables.

- Recommended RS-232C Cables

Model numbers	Manufacturer
UL2464 AWG28x5P IFS-RVV-SB (UL product) AWG28x5P IFVV-SB (non-UL product)	Fujikura Ltd.
UL2464-SB (MA) 5Px28AWG (7/0.127) (UL product) CO-MA-VV-SB 5Px28AWG (7/0.127) (non-UL product)	Hitachi Cable, Ltd.

2 Combine a signal wire and SG (signal ground) wire in a twisted-pair cable.
At the same time, bundle the SG wires at the connectors on Option Board and the remote device.

3 Connect the shield of the communications cable to the hood (FG) of the RS-232C connector on the Option Board.

At the same time, ground the ground terminal (GR) of the CPU Unit to 100 Ω or less.

● Connection Example

Example: Twisted-pair Cable Connecting SD-SG, and RD-SG Terminals in Host Link Mode

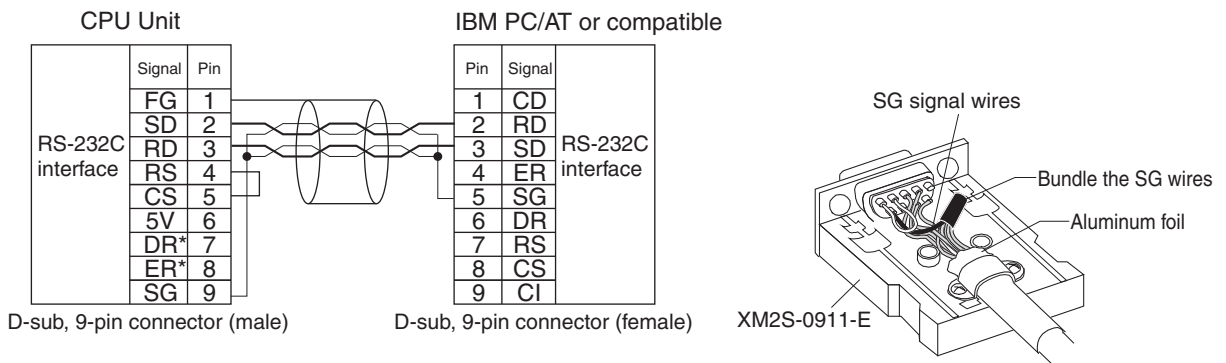

* DR and ER signals are not supported by the N□□S(1)-type CPU Unit.

Note The hood (FG) is internally connected to the ground terminal (GR) on the CPU Unit. Therefore, the FG is grounded by grounding the power supply ground terminal (GR). Although there is conductivity between the hood (FG) and pin 1 (FG), connect the shield to both the hood and pin 1 to reduce the contact resistance between the shield and FG and thus provide better noise resistance.

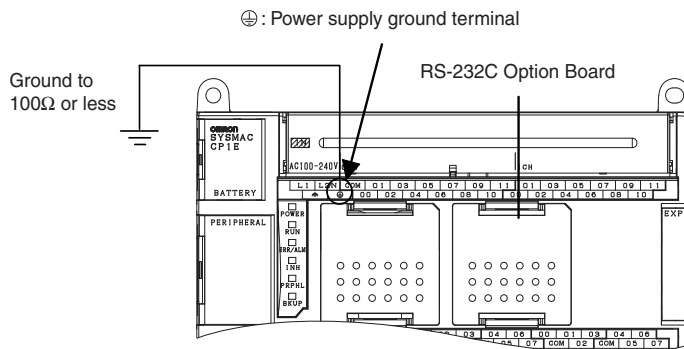

Wiring Connectors

Use the following steps to wire connectors.

See the following diagrams for the length of the cable portion to be cut in each step.

● Shield Connected to Hood (FG)

- 1** Cut the cable to the required length.
- 2** Remove the specified length of the sheath from the cable using a knife. Be careful not to scratch the braided shield.

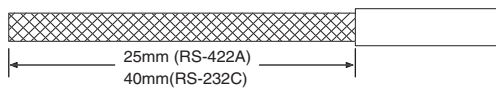

- 3** Trim off the braided shield using scissors.

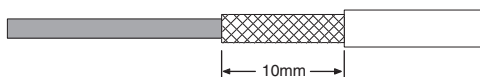

- 4** Remove the insulation from each conductor using a stripper.

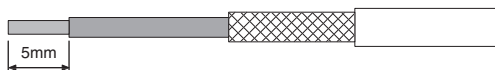

- 5** Fold back the braided shield.



- 6** Wrap aluminum foil tape around the folded shield.



● **Shield Not Connected to Hood (FG)**

- 1** Cut the cable to the required length.
- 2** Remove the specified length of the sheath from the cable using a knife. Be careful not to scratch the braided shield.

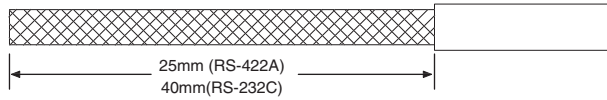

- 3** Trim off all the braided shield using scissors.



- 4** Remove the insulation from each conductor using a stripper.



- 5** Wrap adhesive tape around the conductor from which the braided shield was removed.

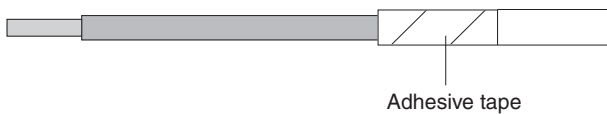

● **Soldering**

- 1** Place a heat-shrinking tube on each conductor.
- 2** Temporarily solder each conductor to the corresponding connector terminals.
- 3** Completely solder each conductor.

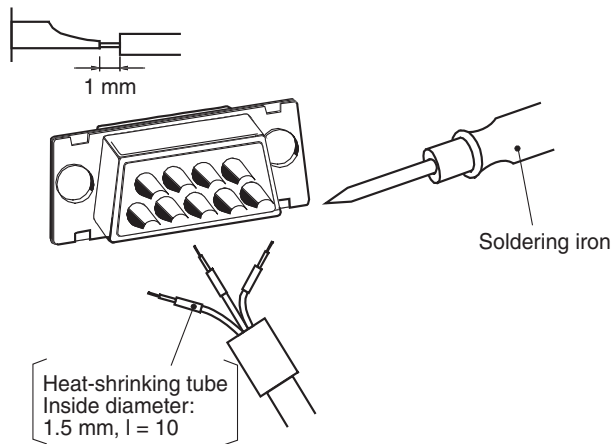

- Return the heat-shrinking tube to the soldered portion, then heat the tube to shrink it in place.

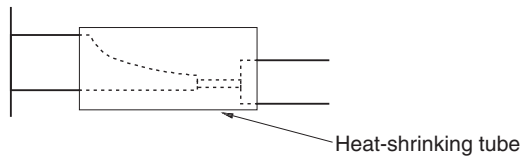

● **Assembling Connector Hood**

Assemble the connector hood as shown below.

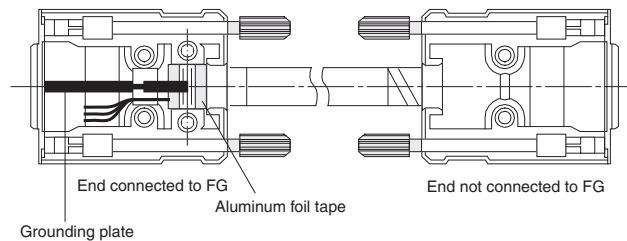

A-3-2 Recommended RS-422A/485 Wiring

Use the following wiring methods for RS-422A/485 to maintain transmission quality.

● **CP1W-CIF11/12 RS-422A/485 Wiring**

- Always use shielded twisted-pair cables as communications cables.

- Recommended RS-422A/485 Cables

Model numbers	Manufacturer
CO-HC-ESV-3P×7/0.2	Hirakawa Hewtech Corp.

- Connect the shield of the communications cable to the FG terminal on the RS-422A/485 Option Board.

At the same time, ground the ground terminal (GR) of the CPU Unit to 100 Ω or less.

● **Built-in RS-485 Wiring (CP1E-N□□S1D□-□)**

Applicable Cables

Solid wire or ferrules can be used.

- Recommended RS-485 Cables

Model numbers	Manufacturer
CO-HC-ESV-3P×7/0.2	Hirakawa Hewtech Corp.

- Recommended ferrules

Manufacturer	Model numbers	Applicable wire
Phoenix Contact	AI-0.25-12	AWG24

Note Do not connect bare stranded wires directly to terminals.

Terminal Wiring

When wiring the Rs-485 terminal block, treat either solid or stranded wires directly.

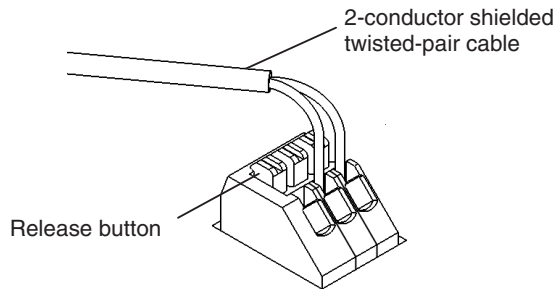

- To make the connection, press the release button in with a small flat blade screwdriver and push the line in while the lock is released. Remove the screwdriver and lock it inside.
- To disconnect the wiring, press the release button in with a small flat blade screwdriver and pull the line out while the lock is released.

Note 1 Note 1 Ferrules with/without plastic sleeve cannot be used.

- 2 When using stranded wire, twist the core so that the barbed wires cannot protrude.
- 3 Do not solder-plate the end of cable.

The screwdriver shown below is recommended for wiring.

Model numbers	Manufacturer
SZS 0.4x2.5	Phoenix Contact

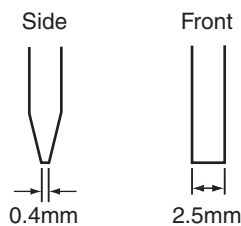

Precautions for Correct Use

Using the Built-in RS-485 Port or CP1W-CIF11 RS-422A/485 Option Board (Not Isolated)

Use the Built-in RS-485 Port or CP1W-CIF11 only when there is no difference in electrical potential between devices. Connect the shield on the communications cable at both ends to the FG terminals on the RS-422A/485 terminal blocks to ground it. Do not allow the communications distance to exceed 50m.

Using the CP1W-CIF12 RS-422A/485 Option Board (Isolated)

Use the CP1W-CIF12 if there is a difference in electrical potential between devices or for long distance communications (500 m max.).

Connect the shield on the communications cable only at the Option Board to ground it. If the shield is connected at both ends of the cable when there is a difference in electrical potential, the devices may be damaged.

● **Connection Examples**

2-Wire and 4-Wire Transmission Circuits

The transmission circuits for 2-wire and 4-wire connections are different, as shown in the following diagram.

- CP1W-CIF11/12

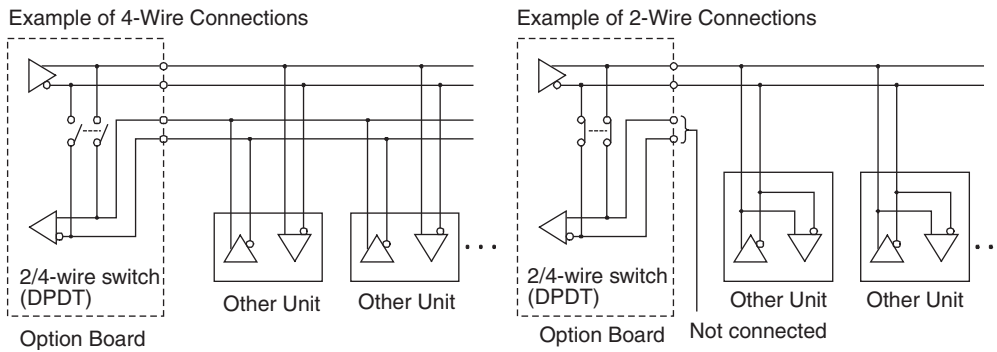

- CP1E-N□□S1D□-□

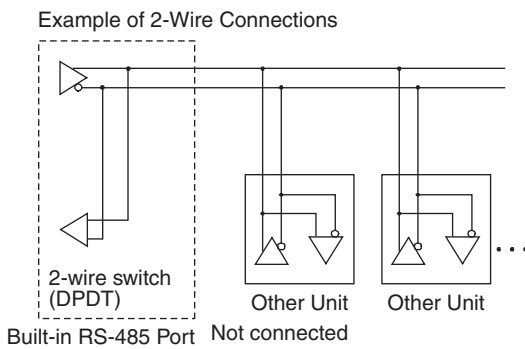

Precautions for Correct Use

Use the same type of transmission circuit (2-wire or 4-wire) for all nodes.
Do not use 4-wire connections when the 2/4-wire switch on the Board is set to 2-wire.

Wiring Example: 1:1 Connections

- Two-wire Connections

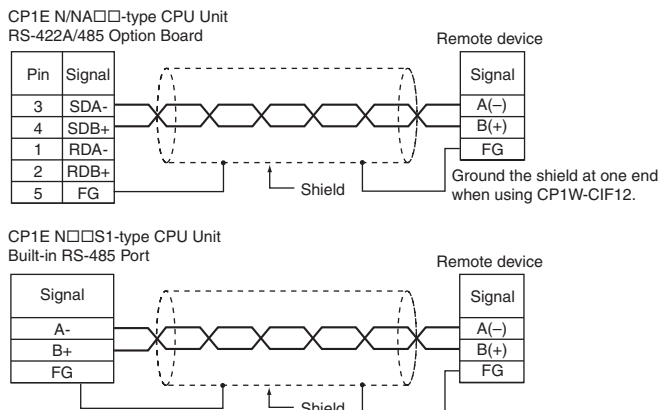

• Four-wire Connections

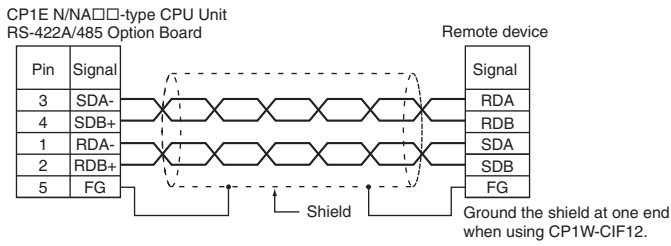

A-3-3 Converting the Built-in RS-232C Port to RS-422A/485

Use one of the following Conversion Units to convert a built-in RS-232C port to an RS-422A port for a CP1E N/NA□□-type CPU Unit.

- CJ1W-CIF11 RS-422A Conversion Unit
Maximum distance: 50 m, convertible to RS-422A or RS-485.
- NT-AL001 RS-232C/RS-422A Conversion Unit:
Maximum distance: 500 m, convertible to RS-422A only.

Note CJ1W-CIF11 cannot be connected to the built-in RS-232C port of the CP1E N□□S(1)-type CPU Unit.

CJ1W-CIF11 RS-422A Conversion Unit

The CJ1W-CIF11 RS-422A Conversion Unit is used to convert an RS-232C port to RS-422A/485. It is directly connected to the built-in RS-232C port of the CP1E N/NA□□-type CPU Unit.

The Conversion Unit is not insulated, so the maximum distance for RS-422A/485 is 50 m.

Note CJ1W-CIF11 cannot be connected to the built-in RS-232C port of the CP1E N□□S(1)-type CPU Unit.

● Appearance

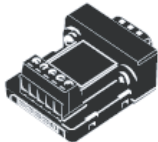

● Electrical Specifications

- RS-422A/485 Terminal Block

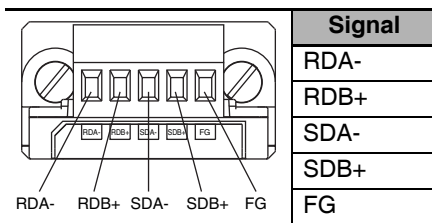

- RS-232C Connector

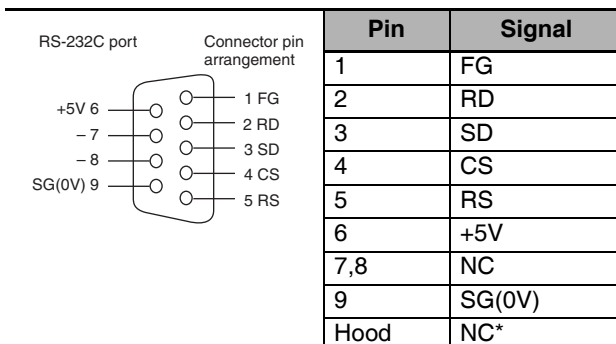

* The hood and the connector hood to which it is connected will have the same electrical potential.

● **DIP Switch for Operation Settings**

Pin	Setting	ON	OFF
1	Terminating resistance selection	Terminating resistance connected (both ends of transmission path)	Terminating resistance not connected
2	2-wire or 4-wire selection*1	2-wire connections	4-wire connections
3	2-wire or 4-wire selection*1	2-wire connections	4-wire connections
4	Not used.	–	–
5	RS control selection for RD*2	RS control enabled	RS control disabled (Data always received.)
6	RS control selection for SD*3	RS control enabled	RS control disabled (Data always sent.)

*1 Set both pins 2 and 3 to either ON (2-wire) or OFF (4-wire).

*2 To disable the echo-back function, set pin 5 to ON (RS control enabled).

*3 When connecting to a device on the N side in a 1: N connection with the 4-wire method, set pin 6 to ON (RS control enabled).

Also, when using 2-wire connections, set pin 6 to ON (RS control enabled).

● **Dimensions**

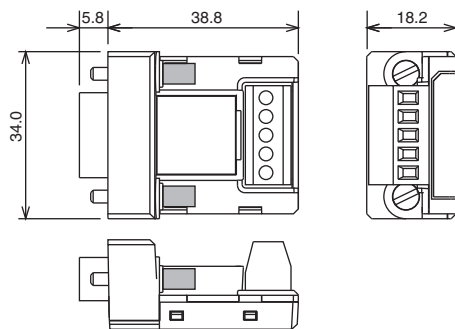

NT-AL001 RS-232C/RS-422A Conversion Unit

The NT-AL001 RS-232C/RS-422A Conversion Unit is used to connect a device with RS-232C terminals to a device with RS-422A terminals.

A cable is used to connect the built-in RS-232C port of the CP1E N/NA□□(S□)-type CPU Unit.

The Conversion Unit is insulated, so the maximum distance for RS-422A is 500 m.

● **Appearance**

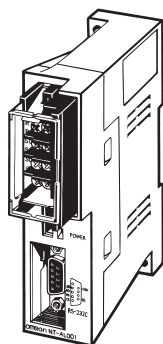

● **DIP Switch Setting**

The NT-AL001 RS-232C/RS-422A Conversion Unit has a DIP switch for setting RS-422A/485 communications conditions.

When connecting the Serial Communications Option Board, refer to the DIP switch settings shown in the following table.

Pin	Function	Factory setting
1	Not used. (Leave set to ON.)	ON
2	Built-in terminating resistance setting ON: Connects terminating resistance, OFF: Disconnects terminating resistance	ON
3	2/4-wire setting	OFF
4	2-wire: Set both pins to ON, 4-wire: Set both pins to OFF	OFF
5	Transmission mode setting*	ON
6	Constant transmission: Set both pins to OFF. Transmission performed when CS signal in RS-232C interface is at high level: Set pin 5 to OFF and pin 6 to ON. Transmission performed when CS signal in RS-232C interface is at low level: Set pin 5 to ON and pin 6 to OFF.	OFF

* When connecting to a CP-series CPU Unit, turn OFF pin 5 and turn ON pin 6.

● **Application Example**

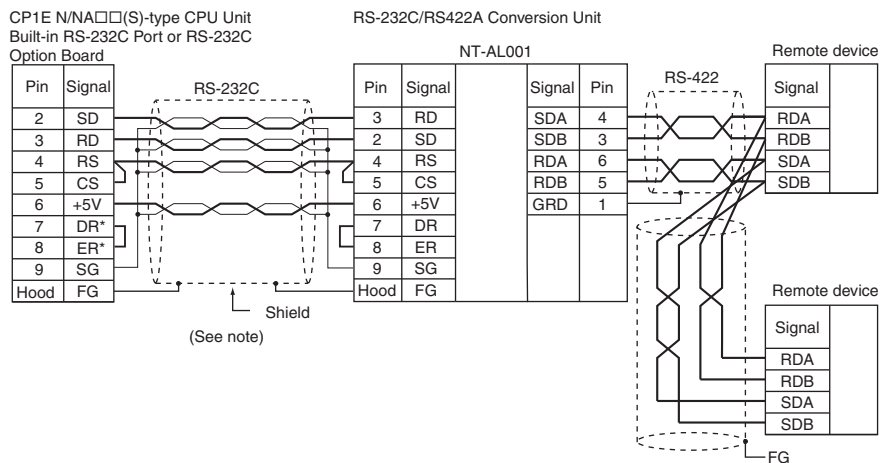

* DR and ER signals are not supported by the N□□S(1)-type CPU Unit.

Note The following cables can be used for this connection.

It is recommended that one of these cables be used to connect the RS-232C port on the Option Board to the NT-AL001 RS-232C/RS-422 Conversion Unit.

Length	Model numbers
70cm	XW2Z-070T-1
2m	XW2Z-200T-1

● **Wiring for the Recommended Cables (XW2Z-070T-1 or XW2Z-200T-1)**

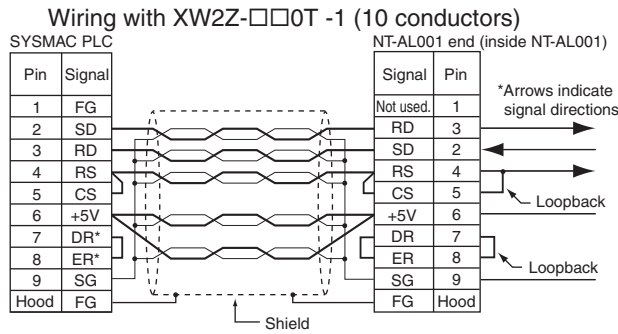

* DR and ER signals are not supported by the N□□S(1)-type CPU Unit.

Note The hood (FG) is internally connected to the ground terminal (GR) on the CPU Unit. Therefore, FG is grounded by grounding the ground terminal (GR) on the power supply terminal block.



Precautions for Correct Use

- The XW2Z-□□0T-1 Connecting Cables for the NT-AL001 Link Adapter uses special wiring for the DS and RS signals. Do not use these signals with other devices. Connecting this cable to other devices can damage them.
- Always turn ON the terminating resistance if the node is at the end of the RS-422A/485 transmission path.

A-3-4 Reducing Electrical Noise for External Wiring

Observe the following precautions when wiring communications cables.

- When multi-conductor signal cable is being used, avoid combining I/O wires and other control wires in the same cable.
- If wiring racks are parallel, allow at least 300 mm between them.

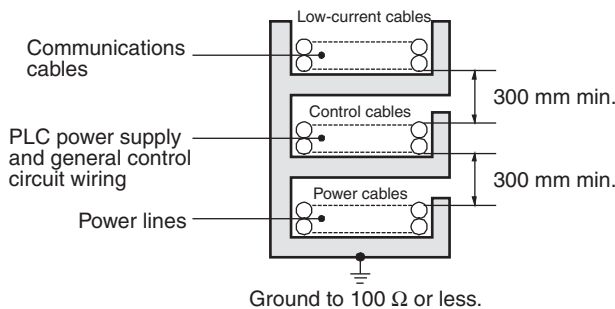

- If the I/O wiring and power cables must be placed in the same duct, they must be shielded from each other using grounded steel sheet metal.

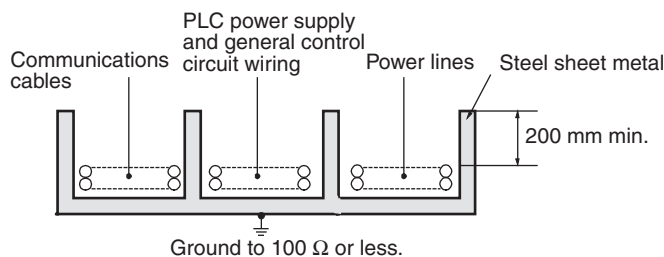

Index

A

Analog adjuster	3-3, 3-8
Analog adjusters	3-3
Analog I/O Unit.....	2-15, 8-27
Dimensions	A-10
DIP Switch settings	8-35
Wiring	8-35, 8-49, A-31, A-33, A-34
Words allocation.....	8-37, 8-51
Analog Input Unit	2-15, 8-2
Dimensions	A-10
Part names and functions	8-2
Specifications	8-3
Wiring	8-8, A-28
Words allocation.....	8-10
Analog Output Unit.....	2-15, 8-15
Dimensions	A-10
Part names and functions	8-15
Specifications	8-16
Wiring	8-22, A-29, A-30
Words allocation.....	8-22, 8-23

B

Backup memory error	6-6, 6-12
Backup time	1-2
Battery.....	2-10, 7-2
Replacing	7-7
Service life.....	7-5
Battery error.....	6-6, 6-13
Built-in RS-232C port.....	3-3, 3-8, A-50

C

Checking errors.....	6-2
Communications error	
Built-in RS-232C port	6-5
Peripheral USB port	6-5
CompoBus/S I/O Link Unit.....	2-16, 8-92
Dimensions	A-11
Node number Determination and DIP switch settings	8-96
Part names and functions	8-92
Specifications	8-94
Wiring	8-96, A-38
Words allocation.....	8-95
Connecting by USB.....	4-8
Connecting Expansion (I/O) Units.....	5-12
CPU error.....	6-5, 6-11
CPU Unit	
Common I/O specifications	3-13
Dimensions	A-2
E10/14/20 or N14/20 CPU Units	3-2
E30/40, N30/40/60 or NA20 CPU Units	3-7
Model numbers	2-4
Models.....	2-4
Part names and functions	3-2, 3-7
Terminal arrangements	3-5, 3-10
Unit version	2-11
Wiring	A-12
Current consumption	
Analog I/O Unit.....	8-29
Analog Input Unit.....	8-3

Analog Output Unit.....	8-17
CPU Unit	2-5, 2-6, 2-7, 2-8, 2-9, 2-19
Expansion I/O Unit	2-20
Expansion Unit.....	2-20
Temperature Sensor Unit.....	8-57
CX-Programmer	4-2
Installation	4-7
Uninstallation.....	4-7
CX-Programmer connection error.....	6-18
Cycle time exceeded error	6-5, 6-10

D

Dimensions	5-7
CPU Unit	A-2
Expansion I/O Unit	A-8
Expansion Unit	A-10
Option Boards	A-5
RS-422A Conversion Unit	A-51
DIN Track.....	2-10, 5-9
DIN Track installation.....	5-8
DIP switch	
Analog I/O Units	8-35
CompoBus/S I/O Link Unit	8-93
RS-232C/RS-422A Conversion Unit	A-52
RS-422A Conversion Unit	A-51
RS-422A/485 Option Board.....	3-21
Temperature Sensor Unit.....	8-58
DM Area capacity.....	1-2, 2-5, 2-6, 2-7, 2-8, 2-9

E

EMC Directive	-23
End Plate	2-10, 5-10
Error log information	6-3
Error processing flowchart	6-6
E-type CPU Unit.....	1-2
Basic system configuration.....	2-2
E10/14/20 or N14/20 CPU Units	3-2
E30/40, N30/40/60 or NA20 CPU Units	3-7
Maximum number of I/O Points.....	2-13
Models.....	2-6
Expansion I/O Unit.....	3-28, 3-31
Common I/O specifications	3-33
Dimensions.....	A-8
Models.....	2-14
Part names and functions.....	3-31
Terminal arrangements	3-32
Wiring	A-21
Expansion Input Unit	
Part names and functions.....	3-28
Terminal arrangements	3-28
Expansion Output Unit	
Part names and functions.....	3-29
Terminal arrangements	3-30
Expansion system configuration	2-13
Expansion Unit	
Dimensions.....	A-10
Models.....	2-15
Wiring	A-28
External power supply capacity	2-16, 2-18

F

Fail-safe circuits	5-2
FAL error	6-6, 6-12
FALS error	6-5, 6-10
Fatal errors	
Cycle time exceeded error	6-5, 6-10
FALS error	6-5, 6-10
I/O bus error	6-5, 6-8
Memory error	6-5, 6-8
Program error	6-5, 6-9
Too many I/O points error	6-5, 6-8

G

Grounding	5-15, 5-16
-----------------	------------

H

High-speed counter	3-13
--------------------------	------

I

I/O bus error	6-5, 6-8
I/O Connecting Cable	2-10
I/O wiring	5-17
Indicator	3-4, 3-9
Checking errors	6-2
Communications errors	6-14
CPU errors	6-11
Errors	6-5
Fatal errors	6-7
Non-fatal errors	6-12
Inductive loads	5-21
Input errors	6-15
Inspection and maintenance	7-3
Installation and Wiring Products	
Models	2-10
Installation height	5-8
Installing the software	4-7
Installing the USB Driver	4-9
Interrupt inputs	3-13

L

Low Voltage Directive	-23
-----------------------------	-----

M

Maximum number of I/O Points	1-10, 2-13
Memory error	6-5, 6-8
Modbus-RTU Easy Master function	A-41
Model numbers	2-4
Models	
CPU Unit	2-4
Expansion I/O Unit	2-14
Expansion Unit	2-15
Installation and Wiring Products	2-10
Optional Products	2-9
Mounting hole pitch	5-10

N

N/NA-type CPU Unit	1-2
Basic system configuration	2-3
E10/14/20 or N14/20 CPU Units	3-2
E30/40, N30/40/60 or NA20 CPU Units	3-7
Models	2-8
Noise control	5-21
External wiring	5-22, A-53
Relay output	5-22

Non-fatal errors

Backup memory error	6-6, 6-12
Battery error	6-6, 6-13
FAL error	6-6, 6-12
Option Board error	6-6, 6-13
PLC Setup error	6-6, 6-13
No-protocol communications	A-40
Normal inputs	3-13
Normal Outputs	3-16
NT Link	A-39
Number of connected Units	5-13
Number of Expansion (I/O) Units connected	
..... 1-10, 2-13, 2-16, 5-13	
Number of simultaneously ON points	2-17

O

Operating environment	4-4
Option Board	3-19
Option Board error	6-6, 6-13
Option Board slot	3-8
Option Boards	
Dimensions	A-5
Optional Products	
Models	2-9
Output errors	6-16
Output wiring	5-20

P

Part names and functions	
Analog Input Unit	8-2
Analog Output Unit	8-15
CompoBus/S I/O Link Unit	8-92
E10/14/20 or N14/20 CPU Units	3-2
E30/40, N30/40/60 or NA20 CPU Units	3-7
Expansion I/O Unit	3-31
Expansion Input Unit	3-28
Expansion Output Unit	3-29
Periodic inspection	7-2
Peripheral USB port	3-3, 3-8, 4-8, 6-18
PLC Setup error	6-6, 6-13
Power consumption	1-9
Power supply error	6-5
Precautions	
Precautions on Connecting Units	5-13
Precautions when connecting a two-wire DC sensor	
..... 5-19	
Restrictions of CPU Unit with 16 or 32 I/O Points ..	3-34
Restrictions on system configuration	2-16
Unit replacement precautions	7-4
Program capacity	1-2, 1-10, 2-5, 2-6, 2-7, 2-8, 2-9
Program error	6-5, 6-9
Programming devices	4-2
Pulse outputs	3-17
PWM output	3-17

Q

Quick-response inputs	3-13
-----------------------------	------

R

Rotary switch	8-59
RS-232C Option Board	2-9, 3-20
Dimensions	A-5
RS-232C/RS-422A Conversion Unit	
Appearance	A-51
DIP Switch for operation settings	A-52

RS-422A Conversion Unit	
Appearance.....	A-50
Dimensions	A-51
DIP Switch for operation settings	A-51
Electrical specifications	A-50
RS-422A/485 Option Board	2-9, 3-21
Dimensions	A-6, A-7

S

Serial communications.....	A-39
Serial Communications Port	3-19, 3-24
Serial PLC Links	A-42
Service life of relays	
CPU Unit	3-15
Expansion I/O Unit	3-34
Specifications	
Analog Input Unit.....	8-3
Analog Output Unit.....	8-16
Characteristics	1-10
CompoBus/S I/O Link Unit	8-94
Functional specifications	1-12
General specifications.....	1-9
Support Software	2-12
Surface installation.....	5-8
System configuration	
E-type CPU Unit.....	2-2
Expansion system configuration	2-13
N/NA-type CPU Unit.....	2-3
Restrictions on system configuration	2-16

T

Temperature Sensor Unit.....	2-15, 2-16, 8-56
Dimensions	A-11
DIP Switch Settings.....	8-58
Rotary Switch Setting.....	8-59
Wiring	A-35, A-37, A-38
Words allocation.....	8-61
Terminal arrangements	
E10/14/20 or N14/20 CPU Units	3-2
E30/40, N30/40/60 or NA20 CPU Units	3-7
Expansion I/O Unit	3-32
Expansion Input Unit.....	3-28
Expansion Output Unit	3-30
Too many I/O points error	6-5, 6-8
Two-decimal-place Mode.....	8-66
Types of errors.....	6-5

U

Uninstalling the software.....	4-7
Uninstalling the USB Driver	4-14
Unit replacement.....	7-4
Unit version.....	2-11

W

WDT error	6-5
Weight	
CPU Unit	1-9, 2-5, 2-6, 2-7, 2-8, 2-9
Expansion I/O Unit	2-14
Expansion Unit	2-15
Wiring	
AC Power Supply	5-14
Analog I/O Unit.....	8-35, 8-49
Analog Input Unit.....	8-8
Analog Output Unit.....	8-22
CompoBus/S I/O Link Unit	8-96

CPU Unit	A-12
DC Power Supply.....	5-16
Expansion I/O Unit	A-21
Expansion Unit	A-28
Ground lines	5-15, 5-16
I/O.....	5-17
Noise control	A-53
Output.....	5-20
Serial communications	A-39, A-44
Wiring connectors.....	A-45
Wiring Diagrams	A-12
Wiring ducts	5-11
Wiring for PTs	A-39
Wiring power supply.....	5-14, 5-16

Revision History

A manual revision code appears as a suffix to the catalog number on the front cover of the manual.

Cat. No. W479-E1-10

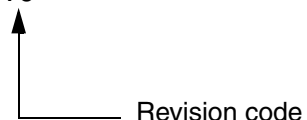

Revision code	Date	Revised content
01	March 2009	Original production
02	June 2009	<ul style="list-style-type: none">Information added on CX-Programmer Micro PLC Edition version 8.2 upgrading to version 9.0.Information added on the features of pulse outputs and PWM outputs.Errors were corrected.
03	January 2010	Information added on E10/14, N14/60 and NA20 CPU Units.
04	June 2010	<ul style="list-style-type: none">CP1W-DA021 added for CP-series Expansion Units.Information added on CP1W-CIF41 Ethernet Option Board.
05	November 2011	Information added on N□□S(1)-type and E□□S-type CPU Units.
06	July 2013	Annotation added on that CJ1W-CIF11 cannot be connected to the built-in RS-232C port of the CP1E N□□S(1)-type CPU Unit.
07	June 2014	Information added on CP1W-ADB21/DAB21V/MAB221 Analog Option Board.
08	October 2014	<ul style="list-style-type: none">CP1W-AD042 Analog Input Units, CP1W-DA042 Analog Output Units, CP1W-MAD42/MAD44 Analog I/O Units and CP1W-TS003/TS004 Temperature Sensor Units added for CP-series Expansion Units.Errors were corrected.
09	January 2016	Added CPU Units with unit version 1.3.
10	July 2017	CP1W-CIF12-V1 added for Serial Communication Option Board.

OMRON Corporation Industrial Automation Company
Kyoto, JAPAN

Contact: www.ia.omron.com

Regional Headquarters

OMRON EUROPE B.V.

Wegalaan 67-69, 2132 JD Hoofddorp
The Netherlands

Tel: (31)2356-81-300/Fax: (31)2356-81-388

OMRON ASIA PACIFIC PTE. LTD.

No. 438A Alexandra Road # 05-05/08 (Lobby 2),
Alexandra Technopark,
Singapore 119967

Tel: (65) 6835-3011/Fax: (65) 6835-2711

OMRON ELECTRONICS LLC

2895 Greenspoint Parkway, Suite 200
Hoffman Estates, IL 60169 U.S.A.

Tel: (1) 847-843-7900/Fax: (1) 847-843-7787

OMRON (CHINA) CO., LTD.

Room 2211, Bank of China Tower,
200 Yin Cheng Zhong Road,
PuDong New Area, Shanghai, 200120, China

Tel: (86) 21-5037-2222/Fax: (86) 21-5037-2200

Authorized Distributor:

© OMRON Corporation 2009 All Rights Reserved.
In the interest of product improvement,
specifications are subject to change without notice.

Cat. No. W479-E1-10

0717