

## SIPROTEC 4 7SJ61 Multifunction Protection Relay



Fig. 5/78 SIPROTEC 4 7SJ61 multifunction protection relay

### Description

The SIPROTEC 4 7SJ61 relays can be used for line protection of high and medium voltage networks with earthed (grounded), low-resistance earthed, isolated or compensated neutral point. When protecting motors, the SIPROTEC 4 7SJ61 is suitable for asynchronous machines of all sizes. The relay performs all functions of backup protection supplementary to transformer differential protection.

The relay provides control of the circuit-breaker, further switching devices and automation functions. The integrated programmable logic (CFC) allows the user to implement their own functions, e. g. for the automation of switchgear (interlocking). The user is also allowed to generate user-defined messages.

The flexible communication interfaces are open for modern communication architectures with control systems.

### Function overview

#### Protection functions

- Time-overcurrent protection (definite-time/inverse-time/user-def.)
- Sensitive earth-fault detection
- Intermittent earth-fault protection
- High-impedance restricted earth fault
- Inrush restraint
- Motor protection
  - Undercurrent monitoring
  - Starting time supervision
  - Restart inhibit
  - Locked rotor
  - Load jam protection
- Overload protection
- Temperature monitoring
- Breaker failure protection
- Negative-sequence protection
- Auto-reclosure
- Lockout

#### Control functions/programmable logic

- Commands for control of a circuit-breaker and of isolators
- Control via keyboard, binary inputs, DIGSI 4 or SCADA system
- User-defined logic with CFC (e.g. interlocking)

#### Monitoring functions

- Operational measured values *I*
- Circuit-breaker wear monitoring
- Slave pointer
- Time metering of operating hours
- Trip circuit supervision
- 8 oscillographic fault records
- Motor statistics

#### Communication interfaces

- System interface
  - IEC 60870-5-103, IEC 61850
  - PROFIBUS-FMS/-DP
  - DNP 3.0/MODBUS RTU
- Service interface for DIGSI 4 (modem)
- Front interface for DIGSI 4
- Time synchronization via IRIG B/DCF77

#### Hardware

- 4 current transformers
- 3/8/11 binary inputs
- 4/8/6 output relays



## Application

ANSI No.	IEC	Protection functions
50, 50N	$I >, I >>, I >>>$ $I_E >, I_E >>, I_E >>>$	Definite-time overcurrent protection (phase/neutral)
51, 51N	$I_p, I_{Ep}$	Inverse-time overcurrent protection (phase/neutral)
50Ns, 51Ns	$I_{EE} >, I_{EE} >>, I_{EEp}$	Sensitive earth-fault protection
–		Cold load pick-up (dynamic setting change)
–	$I_E >$	Intermittent earth fault
87N		High-impedance restricted earth-fault protection
50BF		Breaker failure protection
79		Auto-reclosure
46	$I_2 >$	Phase-balance current protection (negative-sequence protection)
49	$\vartheta >$	Thermal overload protection
48		Starting time supervision
51M		Load jam protection
14		Locked rotor protection
66/86		Restart inhibit
37	$I <$	Undercurrent monitoring
38		Temperature monitoring via external device (RTD-box), e.g. bearing temperature monitoring

## Construction

## Connection techniques and housing with many advantages

1/3-rack sizes is the available housing width of the 7SJ61 relays, referred to a 19" module frame system. This means that previous models can always be replaced. The height is a uniform 244 mm for flush-mounting housings and 266 mm for surface-mounting housing. All cables can be connected with or without ring lugs.

In the case of surface mounting on a panel, the connection terminals are located above and below in the form of screw-type terminals. The communication interfaces are located in a sloped case at the top and bottom of the housing.



Fig. 5/80 Rear view with screw-type terminals

Protection functions

Time-overcurrent protection  
(ANSI 50, 50N, 51, 51N)

This function is based on the phase-selective measurement of the three phase currents and the earth current (four transformers). Three definite-time overcurrent protection elements (DMT) exist both for the phases and for the earth. The current threshold and the delay time can be set within a wide range. In addition, inverse-time overcurrent protection characteristics (IDMTL) can be activated.

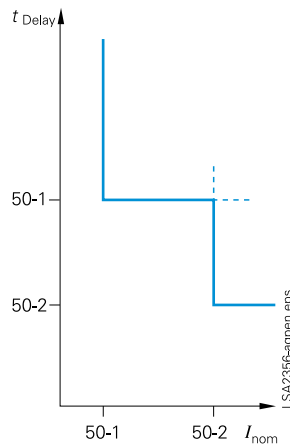

Fig. 5/81  
Definite-time overcurrent protection

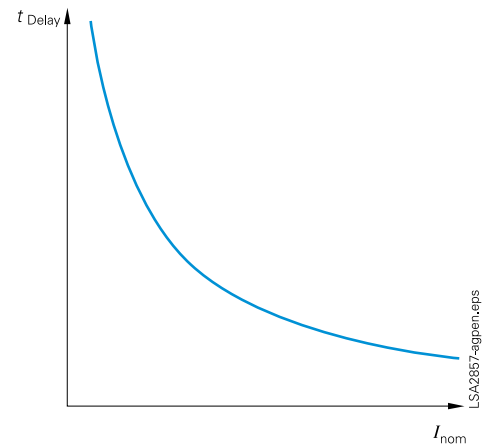

Fig. 5/82  
Inverse-time overcurrent protection

Available inverse-time characteristics

Characteristics acc. to	ANSI/IEEE	IEC 60255-3
Inverse	•	•
Short inverse	•	
Long inverse	•	•
Moderately inverse	•	
Very inverse	•	•
Extremely inverse	•	•

Reset characteristics

For easier time coordination with electro-mechanical relays, reset characteristics according to ANSI C37.112 and IEC 60255-3 / BS 142 standards are applied. When using the reset characteristic (disk emulation), a reset process is initiated after the fault current has disappeared. This reset process corresponds to the reverse movement of the Ferraris disk of an electromechanical relay (thus: disk emulation).

User-definable characteristics

Instead of the predefined time characteristics according to ANSI, tripping characteristics can be defined by the user for phase and earth units separately. Up to 20 current/time value pairs may be programmed. They are set as pairs of numbers or graphically in DIGSI 4.

Inrush restraint

The relay features second harmonic restraint. If the second harmonic is detected during transformer energization, pickup of non-directional normal elements ( $I>$ ,  $I_p$ ) are blocked.

Cold load pickup/dynamic setting change

For time-overcurrent protection functions the initiation thresholds and tripping times can be switched via binary inputs or by time control.

Flexible protection functions

The 7SJ61 units enable the user to easily add on up to 20 protective functions. To this end, parameter definitions are used to link a standard protection logic with any chosen characteristic quantity (measured or derived quantity). The standard logic consists of the usual protection elements such as the pickup message, the parameter-definable delay time, the TRIP command, a blocking possibility, etc. The mode of operation for current quantities can be three-phase or single-phase. The quantities can be operated as greater than or less than stages. All stages operate with protection priority. Protection stages/functions attainable on the basis of the available characteristic quantities:

Function	ANSI No.
$I>$ , $I_E>$	50, 50N
$3I_0>$ , $I_1>$ , $I_2>$ , $I_2/I_1>$	50N, 46
Binary input	

### Protection functions

#### (Sensitive) earth-fault detection (ANSI 50Ns, 51Ns/50N, 51N)

For high-resistance earthed networks, a sensitive input transformer is connected to a phase-balance neutral current transformer (also called core-balance CT).

The function can also be operated in the insensitive mode as an additional short-circuit protection.

#### Intermittent earth-fault protection

Intermittent (re-striking) faults occur due to insulation weaknesses in cables or as a result of water penetrating cable joints. Such faults either simply cease at some stage or develop into lasting short-circuits. During intermittent activity, however, star-point resistors in networks that are impedance-earthed may undergo thermal overloading. The normal earth-fault protection cannot reliably detect and interrupt the current pulses, some of which can be very brief.

The selectivity required with intermittent earth faults is achieved by summing the duration of the individual pulses and by triggering when a (settable) summed time is reached. The response threshold  $I_{EE} >$  evaluates the r.m.s. value, referred to one systems period.

#### Breaker failure protection (ANSI 50BF)

If a faulted portion of the electrical circuit is not disconnected upon issuance of a trip command, another command can be initiated using the breaker failure protection which operates the circuit-breaker, e.g. of an upstream (higher-level) protection relay. Breaker failure is detected if after a trip command, current is still flowing in the faulted circuit. As an option it is possible to make use of the circuit-breaker position indication.

#### Phase-balance current protection (ANSI 46) (Negative-sequence protection)

In line protection, the two-element phase-balance current/negative-sequence protection permits detection on the high side of high-resistance phase-to-phase faults and phase-to-earth faults that are on the low side of a transformer (e.g. with the switch group Dy 5). This provides backup protection for high-resistance faults beyond the transformer.

#### Settable dropout delay times

If the devices are used in parallel with electromechanical relays in networks with intermittent faults, the long dropout times of the electromechanical devices (several hundred milliseconds) can lead to problems in terms of time grading. Clean time grading is only possible if the dropout time is approximately the same. This is why the parameter of dropout times can be defined for certain functions such as time-overcurrent protection, earth short-circuit and phase-balance current protection.

#### Auto-reclosure (ANSI 79)

Multiple reclosures can be defined by the user and lockout will occur if a fault is present after the last reclosure. The following functions are possible:

- 3-pole ARC for all types of faults
- Separate settings for phase and earth faults
- Multiple ARC, one rapid auto-reclosure (RAR) and up to nine delayed auto-reclosures (DAR)
- Starting of the ARC depends on the trip command selection (e.g. 46, 50, 51)
- Blocking option of the ARC via binary inputs
- ARC can be initiated externally or via CFC
- The overcurrent elements can either be blocked or operated non-delayed depending on the auto-reclosure cycle
- Dynamic setting change of the overcurrent elements can be activated depending on the ready AR

#### Thermal overload protection (ANSI 49)

For protecting cables and transformers, an overload protection with an integrated pre-warning element for temperature and current can be applied. The temperature is calculated using a thermal homogeneous-body model (according to IEC 60255-8), which takes account both of the energy entering the equipment and the energy losses. The calculated temperature is constantly adjusted accordingly. Thus, account is taken of the previous load and the load fluctuations.

For thermal protection of motors (especially the stator) a further time constant can be set so that the thermal ratios can be detected correctly while the motor is rotating and when it is stopped. The ambient temperature or the temperature of the coolant can be detected serially via an external temperature monitoring box (resistance-temperature detector box, also called RTD-box). The thermal replica of the

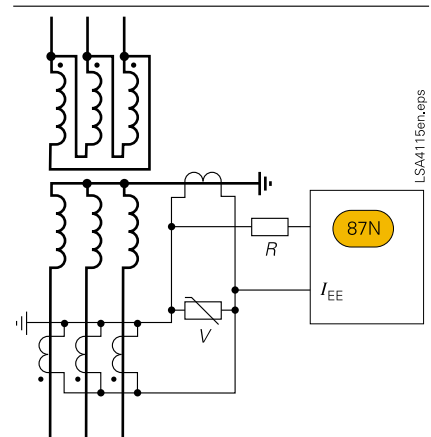

Fig. 5/83 High-impedance restricted earth-fault protection

overload function is automatically adapted to the ambient conditions. If there is no RTD-box it is assumed that the ambient temperatures are constant.

#### High-impedance restricted earth-fault protection (ANSI 87N)

The high-impedance measurement principle is an uncomplicated and sensitive method for detecting earth faults, especially on transformers. It can also be applied to motors, generators and reactors when these are operated on an earthed network.

When the high-impedance measurement principle is applied, all current transformers in the protected area are connected in parallel and operated on one common resistor of relatively high  $R$  whose voltage is measured (see Fig. 5/83). In the case of 7SJ6 units, the voltage is measured by detecting the current through the (external) resistor  $R$  at the sensitive current measurement input  $I_{EE}$ . The varistor  $V$  serves to limit the voltage in the event of an internal fault. It cuts off the high momentary voltage spikes occurring at transformer saturation. At the same time, this results in smoothing of the voltage without any noteworthy reduction of the average value. If no faults have occurred and in the event of external faults, the system is at equilibrium, and the voltage through the resistor is approximately zero. In the event of internal faults, an imbalance occurs which leads to a voltage and a current flow through the resistor  $R$ .

The current transformers must be of the same type and must at least offer a separate core for the high-impedance restricted earth-fault protection. They must in particular have the same transformation ratio and an approximately identical knee-point voltage. They should also demonstrate only minimal measuring errors.

## Protection functions/Functions

## ■ Motor protection

## Starting time supervision (ANSI 48)

Starting time supervision protects the motor against long unwanted start-ups that might occur when excessive load torque occurs, excessive voltage drops occur within the motor or if the rotor is locked. Rotor temperature is calculated from measured stator current. The tripping time is calculated according to the following equation:

for  $I > I_{\text{MOTOR START}}$

$$t = \left( \frac{I_A}{I} \right)^2 \cdot T_A$$

$I$  = Actual current flowing

$I_{\text{MOTOR START}}$  = Pickup current to detect a motor start

$t$  = Tripping time

$I_A$  = Rated motor starting current

$T_A$  = Tripping time at rated motor starting current (2 times, for warm and cold motor)

The characteristic (equation) can be adapted optimally to the state of the motor by applying different tripping times  $T_A$  in dependence of either cold or warm motor state. For differentiation of the motor state the thermal model of the rotor is applied.

If the trip time is rated according to the above formula, even a prolonged start-up and reduced voltage (and reduced start-up current) will be evaluated correctly. The tripping time is inverse (current dependent).

A binary signal is set by a speed sensor to detect a blocked rotor. An instantaneous tripping is effected.

## Temperature monitoring (ANSI 38)

Up to 2 temperature monitoring boxes with a total of 12 measuring sensors can be used for temperature monitoring and detection by the protection relay. The thermal status of motors, generators and transformers can be monitored with this device. Additionally, the temperature of the bearings of rotating machines are monitored for limit value violation. The temperatures are being measured with the help of temperature detectors at various locations of the device to be protected. This data is transmitted to the protection relay via one or two temperature monitoring boxes (see "Accessories", page 5/100).

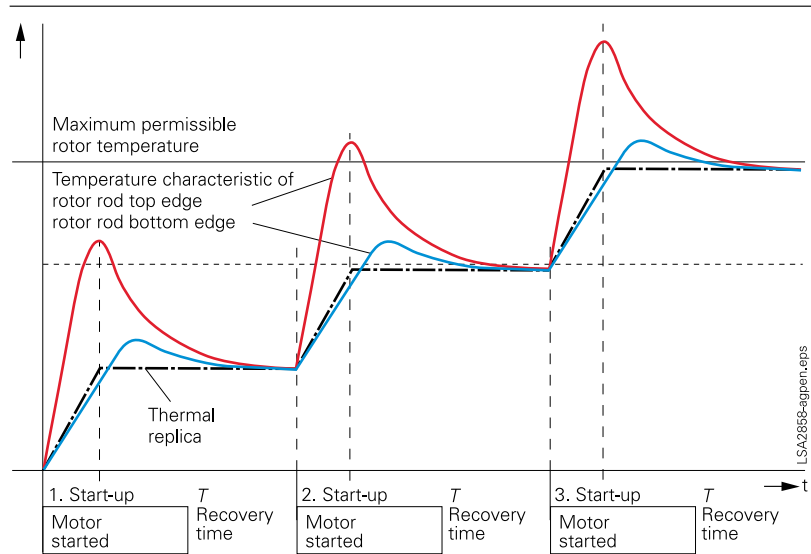

Fig. 5/84

## Load jam protection (ANSI 51M)

Sudden high loads can cause slowing down and blocking of the motor and mechanical damages. The rise of current due to a load jam is being monitored by this function (alarm and tripping). The overload protection function is too slow and therefore not suitable under these circumstances.

## Phase-balance current protection (ANSI 46) (Negative-sequence protection)

The negative-sequence / phase-balance current protection detects a phase failure or load unbalance due to network asymmetry and protects the rotor from impermissible temperature rise.

## Restart inhibit (ANSI 66/86)

If a motor is started up too many times in succession, the rotor can be subject to thermal overload, especially the upper edges of the bars. The rotor temperature is calculated from the stator current. The reclosing lockout only permits start-up of the motor if the rotor has sufficient thermal reserves for a complete start-up (see Fig. 5/84).

## Emergency start-up

This function disables the reclosing lockout via a binary input by storing the state of the thermal replica as long as the binary input is active. It is also possible to reset the thermal replica to zero.

## Undercurrent monitoring (ANSI 37)

With this function, a sudden drop in current, that can occur due to a reduced motor load, is detected. This may be due to shaft breakage, no-load operation of pumps or fan failure.

## Motor statistics

Essential information on start-up of the motor (duration, current, voltage) and general information on number of starts, total operating time, total down time, etc. are saved as statistics in the device.

## Circuit-breaker wear monitoring

Methods for determining circuit-breaker contact wear or the remaining service life of a circuit-breaker (CB) allow CB maintenance intervals to be aligned to their actual degree of wear. The benefit lies in reduced maintenance costs.

There is no mathematically exact method of calculating the wear or the remaining service life of circuit-breakers that takes into account the arc-chamber's physical conditions when the CB opens. This is why various methods of determining CB wear have evolved which reflect the different operator philosophies. To do justice to these, the devices offer several methods:

- $\Sigma I$
- $\Sigma I^x$ , with  $x = 1 \dots 3$
- $\Sigma i^2 t$

The devices additionally offer a new method for determining the remaining service life:

- Two-point method

### Protection functions/Functions

The CB manufacturers double-logarithmic switching cycle diagram (see Fig. 5/85) and the breaking current at the time of contact opening serve as the basis for this method. After CB opening, the two-point method calculates the number of still possible switching cycles. To this end, the two points P1 and P2 only have to be set on the device. These are specified in the CB's technical data.

All of these methods are phase-selective and a limit value can be set in order to obtain an alarm if the actual value falls below or exceeds the limit value during determination of the remaining service life.

### Commissioning

Commissioning could hardly be easier and is fully supported by DIGSI 4. The status of the binary inputs can be read individually and the state of the binary outputs can be set individually. The operation of switching elements (circuit-breakers, disconnect devices) can be checked using the switching functions of the bay controller. The analog measured values are represented as wide-ranging operational measured values.

To prevent transmission of information to the control center during maintenance, the bay controller communications can be disabled to prevent unnecessary data from being transmitted. During commissioning, all indications with test marking for test purposes can be connected to a control and protection system.

### Test operation

During commissioning, all indications can be passed to an automatic control system for test purposes.

### Control and automatic functions

#### Control

In addition to the protection functions, the SIPROTEC 4 units also support all control and monitoring functions that are required for operating medium-voltage or high-voltage substations.

The main application is reliable control of switching and other processes.

The status of primary equipment or auxiliary devices can be obtained from auxiliary contacts and communicated to the 7SJ61 via binary inputs. Therefore it is possible to detect and indicate both the OPEN and CLOSED position or a fault or intermediate circuit-breaker or auxiliary contact position.

The switchgear or circuit-breaker can be controlled via:

- integrated operator panel
- binary inputs
- substation control and protection system
- DIGSI 4

### Automation / user-defined logic

With integrated logic, the user can set, via a graphic interface (CFC), specific functions for the automation of switchgear or substation. Functions are activated via function keys, binary input or via communication interface.

### Switching authority

Switching authority is determined according to parameters, communication or by key-operated switch (when available).

If a source is set to "LOCAL", only local switching operations are possible. The following sequence of switching authority is laid down: "LOCAL"; DIGSI PC program, "REMOTE".

### Command processing

All the functionality of command processing is offered. This includes the processing of single and double commands with or without feedback, sophisticated monitoring of the control hardware and software, checking of the external process, control actions using functions such as runtime monitoring and automatic command termination after output. Here are some typical applications:

- Single and double commands using 1, 1 plus 1 common or 2 trip contacts
- User-definable bay interlocks
- Operating sequences combining several switching operations such as control of circuit-breakers, disconnectors and earthing switches
- Triggering of switching operations, indications or alarm by combination with existing information

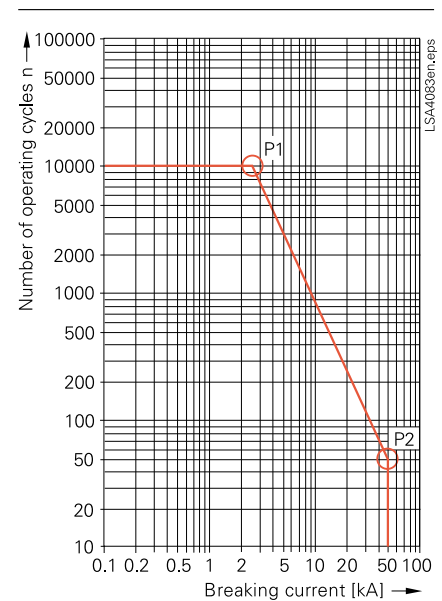

Fig. 5/85 CB switching cycle diagram

### Assignment of feedback to command

The positions of the circuit-breaker or switching devices and transformer taps are acquired by feedback. These indication inputs are logically assigned to the corresponding command outputs. The unit can therefore distinguish whether the indication change is a consequence of switching operation or whether it is a spontaneous change of state.

### Chatter disable

Chatter disable feature evaluates whether, in a configured period of time, the number of status changes of indication input exceeds a specified figure. If exceeded, the indication input is blocked for a certain period, so that the event list will not record excessive operations.

## Functions

### Indication filtering and delay

Binary indications can be filtered or delayed.

Filtering serves to suppress brief changes in potential at the indication input. The indication is passed on only if the indication voltage is still present after a set period of time. In the event of indication delay, there is a wait for a preset time. The information is passed on only if the indication voltage is still present after this time.

### Indication derivation

A further indication (or a command) can be derived from an existing indication. Group indications can also be formed. The volume of information to the system interface can thus be reduced and restricted to the most important signals.

### Measured values

The r.m.s. values are calculated from the acquired current. The following functions are available for measured value processing:

- Currents  $I_{L1}$ ,  $I_{L2}$ ,  $I_{L3}$ ,  $I_E$ ,  $I_{EE}$  (50Ns)
- Symmetrical components  
 $I_1$ ,  $I_2$ ,  $3I_0$
- Mean as well as minimum and maximum current values
- Operating hours counter
- Mean operating temperature of overload function
- Limit value monitoring
- Limit values are monitored using programmable logic in the CFC. Commands can be derived from this limit value indication.
- Zero suppression  
In a certain range of very low measured values, the value is set to zero to suppress interference.

### Metered values

If an external meter with a metering pulse output is available, the SIPROTEC 4 unit can obtain and process metering pulses via an indication input.

The metered values can be displayed and passed on to a control center as an accumulation with reset.

### Switchgear cubicles for high/medium voltage

All units are designed specifically to meet the requirements of high/medium-voltage applications.

In general, no separate measuring instruments or additional control components are necessary.



Fig. 5/86  
NXAIR panel (air-insulated)

LSP2077/eips

## Communication

In terms of communication, the units offer substantial flexibility in the context of connection to industrial and power automation standards. Communication can be extended or added on thanks to modules for retrofitting on which the common protocols run. Therefore, also in the future it will be possible to optimally integrate units into the changing communication infrastructure, for example in Ethernet networks (which will also be used increasingly in the power supply sector in the years to come).

### Serial front interface

There is a serial RS232 interface on the front of all the units. All of the unit's functions can be set on a PC by means of the DIGSI 4 protection operation program. Commissioning tools and fault analysis are also built into the program and are available through this interface.

### Rear-mounted interfaces<sup>1)</sup>

A number of communication modules suitable for various applications can be fitted in the rear of the flush-mounting housing. In the flush-mounting housing, the modules can be easily replaced by the user. The interface modules support the following applications:

- **Time synchronization interface**  
All units feature a permanently integrated electrical time synchronization interface. It can be used to feed timing telegrams in IRIG-B or DCF77 format into the units via time synchronization receivers.
- **System interface**  
Communication with a central control system takes place through this interface. Radial or ring type station bus topologies can be configured depending on the chosen interface. Furthermore, the units can exchange data through this interface via Ethernet and IEC 61850 protocol and can also be operated by DIGSI.
- **Service interface**  
The service interface was conceived for remote access to a number of protection units via DIGSI. On all units, it can be an electrical RS232/RS485 or an optical interface. For special applications, a maximum of two temperature monitoring boxes (RTD-box) can be connected to this interface as an alternative.

### System interface protocols (retrofittable)

#### IEC 61850 protocol

Since 2004, the Ethernet-based IEC 61850 protocol is the worldwide standard for protection and control systems used by power supply corporations. Siemens was the first manufacturer to support this standard. By means of this protocol, information can also be exchanged directly between bay units so as to set up simple masterless systems for bay and system interlocking. Access to the units via the Ethernet bus is also possible with DIGSI.

#### IEC 60870-5-103 protocol

The IEC 60870-5-103 protocol is an international standard for the transmission of protective data and fault recordings. All messages from the unit and also control commands can be transferred by means of published, Siemens-specific extensions to the protocol. Redundant solutions are also possible. Optionally it is possible to read out and alter individual parameters (only possible with the redundant module).

#### PROFIBUS-DP protocol

PROFIBUS-DP is the most widespread protocol in industrial automation. Via PROFIBUS-DP, SIPROTEC units make their information available to a SIMATIC controller or, in the control direction, receive commands from a central SIMATIC. Measured values can also be transferred.

#### MODBUS RTU protocol

This uncomplicated, serial protocol is mainly used in industry and by power supply corporations, and is supported by a number of unit manufacturers. SIPROTEC units function as MODBUS slaves, making their information available to a master or receiving information from it. A time-stamped event list is available.

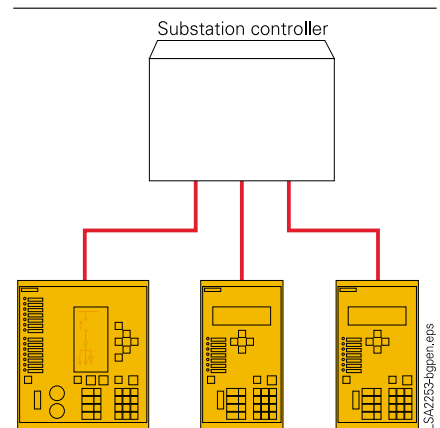

Fig. 5/87  
IEC 60870-5-103: Radial fiber-optic connection

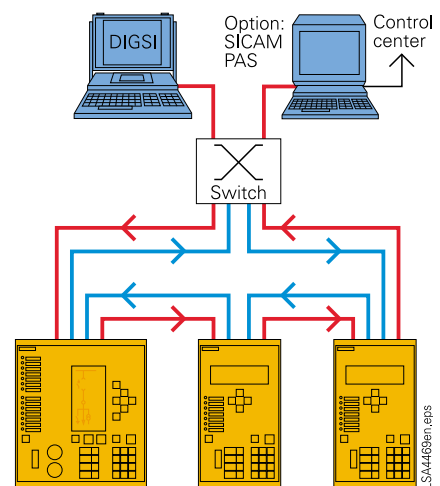

Fig. 5/88  
Bus structure for station bus with Ethernet and IEC 61850, fiber-optic ring

1) For units in panel surface-mounting housings please refer to note on page 5/99.

Communication

DNP 3.0 protocol

Power supply corporations use the serial DNP 3.0 (Distributed Network Protocol) for the station and network control levels. SIPROTEC units function as DNP slaves, supplying their information to a master system or receiving information from it.

System solutions for protection and station control

Together with the SICAM power automation system, SIPROTEC 4 can be used with PROFIBUS-FMS. Over the low-cost electrical RS485 bus, or interference-free via the optical double ring, the units exchange information with the control system.

Units featuring IEC 60870-5-103 interfaces can be connected to SICAM in parallel via the RS485 bus or radially by fiber-optic link. Through this interface, the system is open for the connection of units of other manufacturers (see Fig. 5/87).

Because of the standardized interfaces, SIPROTEC units can also be integrated into systems of other manufacturers or in SIMATIC. Electrical RS485 or optical interfaces are available. The optimum physical data transfer medium can be chosen thanks to opto-electrical converters. Thus, the RS485 bus allows low-cost wiring in the cubicles and an interference-free optical connection to the master can be established.

For IEC 61850, an interoperable system solution is offered with SICAM PAS. Via the 100 Mbits/s Ethernet bus, the units are linked with PAS electrically or optically to the station PC. The interface is standardized, thus also enabling direct connection of units of other manufacturers to the Ethernet bus. With IEC 61850, however, the units can also be used in other manufacturers' systems (see Fig. 5/88).

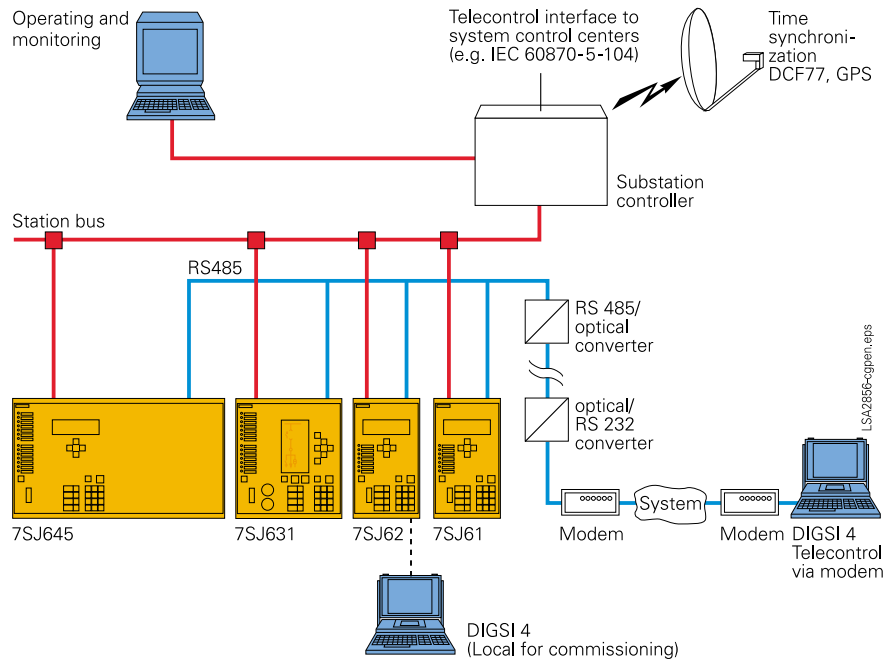

Fig. 5/89 System solution/communication



Fig. 5/90 Optical Ethernet communication module for IEC 61850 with integrated Ethernet-switch

### Typical connections

#### ■ Connection of current and voltage transformers

##### Standard connection

For earthed networks, the earth current is obtained from the phase currents by the residual current circuit.

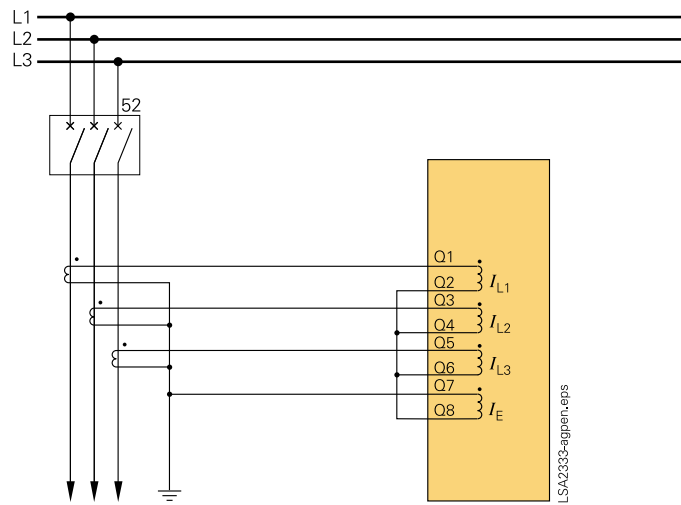

Fig. 5/91  
Residual current  
circuit

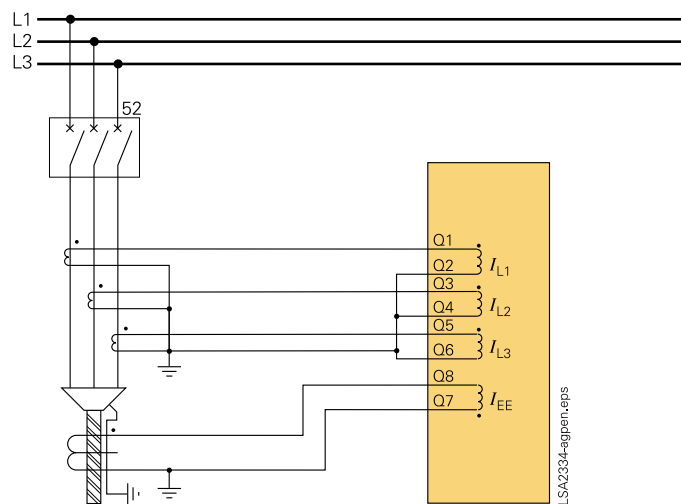

Fig. 5/92  
Sensitive earth  
current detection

Typical applications

Overview of connection types

Type of network	Function	Current connection
(Low-resistance) earthed network	Time-overcurrent protection phase/earth non-directional	Residual circuit, with 3 phase-current transformers required, phase-balance neutral current transformer possible
(Low-resistance) earthed networks	Sensitive earth-fault protection	Phase-balance neutral current transformers required
Isolated or compensated networks	Time-overcurrent protection phases non-directional	Residual circuit, with 3 or 2 phase current transformers possible
Isolated networks	Sensitive earth-fault protection	Phase-balance neutral current transformers required
Compensated networks	Sensitive earth-fault protection	Phase-balance neutral current transformers required

5

Trip circuit supervision (ANSI 74TC)

One or two binary inputs can be used for monitoring the circuit-breaker trip coil including its incoming cables. An alarm signal occurs whenever the circuit is interrupted.

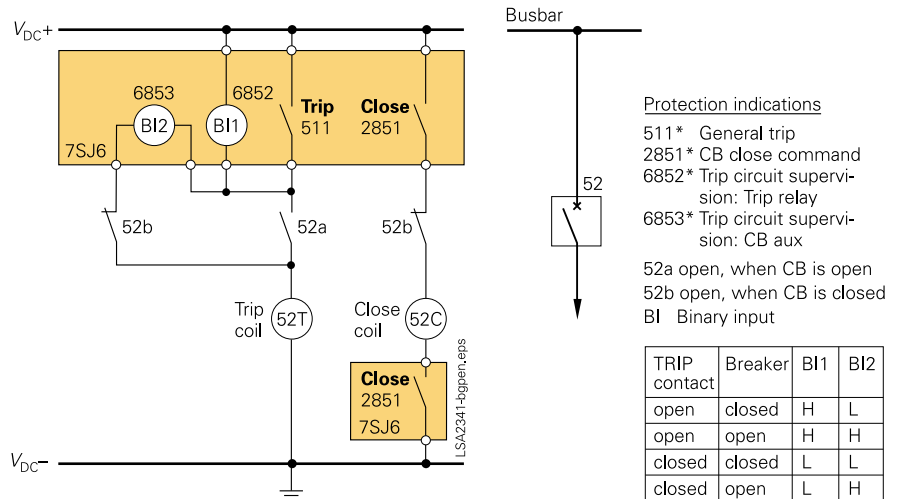

Fig. 5/93 Trip circuit supervision with 2 binary inputs

## Technical data

### General unit data

#### Measuring circuits

System frequency 50 / 60 Hz (settable)

#### Current transformer

Rated current  $I_{nom}$  1 or 5 A (settable)

Option: sensitive earth-fault CT  $I_{EE} < 1.6$  A

Power consumption  
 at  $I_{nom} = 1$  A Approx. 0.05 VA per phase  
 at  $I_{nom} = 5$  A Approx. 0.3 VA per phase  
 for sensitive earth-fault CT at 1 A Approx. 0.05 VA

Overload capability  
 Thermal (effective)  
 100 x  $I_{nom}$  for 1 s  
 30 x  $I_{nom}$  for 10 s  
 4 x  $I_{nom}$  continuous  
 Dynamic (impulse current) 250 x  $I_{nom}$  (half cycle)

Overload capability if equipped with sensitive earth-fault CT  
 Thermal (effective)  
 300 A for 1 s  
 100 A for 10 s  
 15 A continuous  
 Dynamic (impulse current) 750 A (half cycle)

#### Auxiliary voltage (via integrated converter)

Rated auxiliary voltage  $V_{aux}$   
 DC 24/48 V 60/125 V 110/250 V  
 AC 115/230 V  
 Permissible tolerance  
 DC 19–58 V 48–150 V 88–330 V  
 AC 92–138 V 184–265 V

Ripple voltage, peak-to-peak  $\leq 12\%$

Power consumption  
 Quiescent Approx. 3 W  
 Energized Approx. 7 W

Backup time during loss/short-circuit of auxiliary voltage  
 $\geq 50$  ms at  $V \geq 110$  V DC  
 $\geq 20$  ms at  $V \geq 24$  V DC  
 $\geq 200$  ms at 115 V/230 V AC

#### Binary inputs/indication inputs

Type	7SJ610	7SJ611	7SJ612
Number	3	8	11
Voltage range	24–250 V DC		
Pickup threshold	Modifiable by plug-in jumpers		
Pickup threshold	DC 19 V		88 V
For rated control voltage	DC 24/48/60/110/125 V		110/220/250 V
Response time/drop-out time	Approx. 3.5 ms		
Power consumption energized	1.8 mA (independent of operating voltage)		

#### Binary outputs/command outputs

Type	7SJ610	7SJ611	7SJ612
Number command/indication relay	4	8	6
Contacts per command/indication relay	1 NO / form A (2 contacts changeable to NC/form B, via jumpers)		
Live status contact	1 NO / NC (jumper) / form A / B		
Switching capacity	Make	1000 W / VA	
	Break	30 W / VA / 40 W resistive / 25 W at L/R $\leq 50$ ms	
Switching voltage	$\leq 250$ V DC		

Permissible current  
 5 A continuous,  
 30 A for 0.5 s making current,  
 2000 switching cycles

#### Electrical tests

##### Specification

Standards IEC 60255  
 ANSI C37.90, C37.90.1, C37.90.2,  
 UL508

##### Insulation tests

Standards IEC 60255-5; ANSI/IEEE C37.90.0  
 Voltage test (100 % test)  
 all circuits except for auxiliary voltage and RS485/RS232 and time synchronization 2.5 kV (r.m.s. value), 50/60 Hz  
 Auxiliary voltage 3.5 kV DC  
 Communication ports and time synchronization 500 V AC  
 Impulse voltage test (type test)  
 all circuits, except communication ports and time synchronization, class III 5 kV (peak value); 1.2/50  $\mu$ s; 0.5 J  
 3 positive and 3 negative impulses at intervals of 5 s

##### EMC tests for interference immunity; type tests

Standards IEC 60255-6; IEC 60255-22 (product standard)  
 EN 50082-2 (generic specification)  
 DIN 57435 Part 303  
 High-frequency test IEC 60255-22-1, class III and VDE 0435 Part 303, class III 2.5 kV (peak value); 1 MHz;  $\tau = 15$  ms; 400 surges per s; test duration 2 s  
 Electrostatic discharge IEC 60255-22-2 class IV and EN 61000-4-2, class IV 8 kV contact discharge; 15 kV air gap discharge; both polarities; 150 pF;  $R_i = 330 \Omega$   
 Irradiation with radio-frequency field, non-modulated IEC 60255-22-3 (Report) class III 10 V/m; 27 to 500 MHz  
 Irradiation with radio-frequency field, amplitude-modulated IEC 61000-4-3; class III 10 V/m, 80 to 1000 MHz; AM 80 %; 1 kHz  
 Irradiation with radio-frequency field, pulse-modulated IEC 61000-4-3/ENV 50204; class III 10 V/m, 900 MHz; repetition rate 200 Hz, on duration 50 %  
 Fast transient interference/burst IEC 60255-22-4 and IEC 61000-4-4, class IV 4 kV; 5/50 ns; 5 kHz; burst length = 15 ms; repetition rate 300 ms; both polarities;  $R_i = 50 \Omega$ ; test duration 1 min  
 High-energy surge voltages (Surge) IEC 61000-4-5; class III  
 Auxiliary voltage From circuit to circuit: 2 kV; 12  $\Omega$ ; 9  $\mu$ F  
 across contacts: 1 kV; 2  $\Omega$ ; 18  $\mu$ F  
 Binary inputs/outputs From circuit to circuit: 2 kV; 42  $\Omega$ ; 0.5  $\mu$ F  
 across contacts: 1 kV; 42  $\Omega$ ; 0.5  $\mu$ F  
 Line-conducted HF, amplitude-modulated IEC 61000-4-6, class III 10 V; 150 kHz to 80 MHz; AM 80 %; 1 kHz  
 Power frequency magnetic field IEC 61000-4-8, class IV IEC 60255-6 30 A/m; 50 Hz, continuous  
 300 A/m; 50 Hz, 3 s  
 0.5 mT, 50 Hz  
 Oscillatory surge withstand capability ANSI/IEEE C37.90.1 2.5 to 3 kV (peak value), 1 to 1.5 MHz  
 damped wave; 50 surges per s; duration 2 s,  $R_i = 150$  to 200  $\Omega$

## Technical data

**EMC tests for interference immunity; type tests (cont'd)**

Fast transient surge withstand capability ANSI/IEEE C37.90.1	4 to 5 kV; 10/150 ns; 50 surges per s both polarities; duration 2 s, $R_i = 80 \Omega$
Radiated electromagnetic interference ANSI/IEEE C37.90.2	35 V/m; 25 to 1000 MHz; amplitude and pulse-modulated
Damped wave IEC 60694 / IEC 61000-4-12	2.5 kV (peak value, polarity alternating) 100 kHz, 1 MHz, 10 and 50 MHz, $R_i = 200 \Omega$

**EMC tests for interference emission; type tests**

Standard	EN 50081-* (generic specification)
Conducted interferences only auxiliary voltage IEC/CISPR 22	150 kHz to 30 MHz Limit class B
Radio interference field strength IEC/CISPR 11	30 to 1000 MHz Limit class B
Units with a detached operator panel must be installed in a metal cubicle to maintain limit class B	

**Mechanical stress tests****Vibration, shock stress and seismic vibration**During operation

Standards	IEC 60255-21 and IEC 60068-2
Vibration IEC 60255-21-1, class 2 IEC 60068-2-6	Sinusoidal 10 to 60 Hz; +/- 0.075 mm amplitude; 60 to 150 Hz; 1 g acceleration frequency sweep 1 octave/min 20 cycles in 3 perpendicular axes
Shock IEC 60255-21-2, class 1 IEC 60068-2-27	Semi-sinusoidal Acceleration 5 g, duration 11 ms; 3 shocks in both directions of 3 axes
Seismic vibration IEC 60255-21-3, class 1 IEC 60068-3-3	Sinusoidal 1 to 8 Hz: $\pm 3.5$ mm amplitude (horizontal axis) 1 to 8 Hz: $\pm 1.5$ mm amplitude (vertical axis) 8 to 35 Hz: 1 g acceleration (horizontal axis) 8 to 35 Hz: 0.5 g acceleration (vertical axis) Frequency sweep 1 octave/min 1 cycle in 3 perpendicular axes

During transportation

Standards	IEC 60255-21 and IEC 60068-2
Vibration IEC 60255-21-1, class 2 IEC 60068-2-6	Sinusoidal 5 to 8 Hz: $\pm 7.5$ mm amplitude; 8 to 150 Hz; 2 g acceleration, frequency sweep 1 octave/min 20 cycles in 3 perpendicular axes
Shock IEC 60255-21-2, Class 1 IEC 60068-2-27	Semi-sinusoidal Acceleration 15 g, duration 11 ms 3 shocks in both directions of 3 axes
Continuous shock IEC 60255-21-2, class 1 IEC 60068-2-29	Semi-sinusoidal Acceleration 10 g, duration 16 ms 1000 shocks in both directions of 3 axes

**Climatic stress tests****Temperatures**

Type-tested acc. to IEC 60068-2-1 and -2, test Bd, for 16 h	-25 °C to +85 °C / -13 °F to +185 °F
Temporarily permissible operating temperature, tested for 96 h	-20 °C to +70 °C / -4 °F to -158 °F
Recommended permanent operating temperature acc. to IEC 60255-6 (Legibility of display may be impaired above +55 °C / +131 °F)	-5 °C to +55 °C / +25 °F to +131 °F
– Limiting temperature during permanent storage	-25 °C to +55 °C / -13 °F to +131 °F
– Limiting temperature during transport	-25 °C to +70 °C / -13 °F to +158 °F

**Humidity**

Permissible humidity It is recommended to arrange the units in such a way that they are not exposed to direct sunlight or pronounced temperature changes that could cause condensation.	Annual average 75 % relative humidity; on 56 days a year up to 95 % relative humidity; condensation not permissible!
--	--

**Unit design**

Housing	7XP20
Dimensions	See dimension drawings, part 17
Weight	
Surface-mounting housing	4.5 kg
Flush-mounting housing	4.0 kg
Degree of protection acc. to EN 60529	
Surface-mounting housing	IP 51
Flush-mounting housing	Front: IP 51, rear: IP 20;
Operator safety	IP 2x with cover

**Serial interfaces****Operating interface (front of unit)**

Connection	Non-isolated, RS232; front panel, 9-pin subminiature connector
Transmission rate	Factory setting 115200 baud, min. 4800 baud, max. 115200 baud

**Service/modem interface (rear of unit)**

Isolated interface for data transfer	Port C: DIGSI 4/modem/RTD-box
Transmission rate	Factory setting 38400 baud, min. 4800 baud, max. 115200 baud

**RS232/RS485**

Connection	
For flush-mounting housing/surface-mounting housing with detached operator panel	9-pin subminiature connector, mounting location "C"
For surface-mounting housing with two-tier terminal at the top/bottom part	At the bottom part of the housing: shielded data cable
Distance RS232	15 m / 49.2 ft
Distance RS485	Max. 1 km / 3300 ft
Test voltage	500 V AC against earth

## Technical data

**System interface (rear of unit)****IEC 60870-5-103 protocol**

Isolated interface for data transfer to a control center	Port B
Transmission rate	Factory setting 9600 baud, min. 1200 baud, max. 115200 baud

**RS232/RS485**

Connection For flush-mounting housing/ surface-mounting housing with detached operator panel	Mounting location "B"
For surface-mounting housing with two-tier terminal on the top/bottom part	At the bottom part of the housing; shielded data cable
Distance RS232	Max. 15 m/49 ft
Distance RS485	Max. 1 km/3300 ft
Test voltage	500 V AC against earth

**Fiber optic**

Connection fiber-optic cable  For flush-mounting housing/ surface-mounting housing with detached operator panel	Integrated ST connector for fiber- optic connection Mounting location "B"
For surface-mounting housing with two-tier terminal on the top/bottom part	At the bottom part of the housing
Optical wavelength	820 nm
Permissible path attenuation	Max. 8 dB, for glass fiber 62.5/125 µm
Distance	Max. 1.5 km/0.9 miles

**IEC 60870-5-103 protocol, redundant****RS485**

Connection For flush-mounting housing/ surface-mounting housing with detached operator panel	Mounting location "B"
For surface-mounting housing with two-tier terminal on the top/bottom part	(not available)
Distance RS485	Max. 1 km/3300 ft
Test voltage	500 V AC against earth

**IEC 61850 protocol**

Isolated interface for data transfer: - to a control center - with DIGSI - between SIPROTEC 4 relays	Port B, 100 Base T acc. to IEEE802.3
---	--------------------------------------

Transmission rate	100 Mbit
-------------------	----------

**Ethernet, electrical**

Connection For flush-mounting housing/ surface-mounting housing with detached operator panel	Two RJ45 connectors mounting location "B"
Distance	Max. 20 m / 65.6 ft
Test voltage	500 V AC against earth

**Ethernet, optical**

Connection For flush-mounting housing/ surface-mounting housing with detached operator panel	Integr. ST connector for FO connection Mounting location "B"
Optical wavelength	1300 nm
Distance	1.5 km/0.9 miles

**PROFIBUS-FMS/DP**

Isolated interface for data transfer to a control center	Port B
Transmission rate	Up to 1.5 Mbaud

**RS485**

Connection For flush-mounting housing/ surface-mounting housing with detached operator panel	9-pin subminiature connector, mounting location "B"
For surface-mounting housing with two-tier terminal on the top/bottom part	At the bottom part of the housing; shielded data cable
Distance	1000 m/3300 ft ≤ 93.75 kbaud; 500 m/1500 ft ≤ 187.5 kbaud; 200 m/600 ft ≤ 1.5 Mbaud; 100 m/300 ft ≤ 12 Mbaud
Test voltage	500 V AC against earth

**Fiber optic**

Connection fiber-optic cable For flush-mounting housing/ surface-mounting housing with detached operator panel	Integr. ST connector for FO connection Mounting location "B"
For surface-mounting housing with two-tier terminal on the top/bottom part	At the bottom part of the housing <b>Important:</b> Please refer to footnotes <sup>1)</sup> and <sup>2)</sup> on page 5/99
Optical wavelength	820 nm
Permissible path attenuation	Max. 8 dB, for glass fiber 62.5/125 µm
Distance	500 kB/s 1.6 km/0.99 miles 1500 kB/s 530 m/0.33 miles

**MODBUS RTU, ASCII, DNP 3.0**

Isolated interface for data transfer to a control center	Port B
Transmission rate	Up to 19200 baud

**RS485**

Connection For flush-mounting housing/ surface-mounting housing with detached operator panel	9-pin subminiature connector, mounting location "B"
For surface-mounting housing with two-tier terminal at the top/bottom part	At bottom part of the housing; shielded data cable
Distance	Max. 1 km/3300 ft max. 32 units recommended
Test voltage	500 V AC against earth

**Fiber-optic**

Connection fiber-optic cable  For flush-mounting housing/ surface-mounting housing with detached operator panel	Integrated ST connector for fiber-optic connection Mounting location "B"
For surface-mounting housing with two-tier terminal at the top/bottom part	At the bottom part of the housing <b>Important:</b> Please refer to footnotes <sup>1)</sup> and <sup>2)</sup> on page 5/99
Optical wavelength	820 nm
Permissible path attenuaion	Max. 8 dB, for glass fiber 62.5/125 µm
Distance	Max. 1.5 km/0.9 miles

## Technical data

**Time synchronization DCF77/IRIG-B signal (Format IRIG-B000)**

Connection	9-pin subminiature connector (SUB-D) (terminal with surface-mounting housing)
Voltage levels	5 V, 12 V or 24 V (optional)

**Functions****Definite-time overcurrent protection (ANSI 50, 50N)**

Operating mode phase protection (ANSI 50)	3-phase (standard) or 2-phase (L1 and L3)
Number of elements (stages)	$I>$ , $I>>$ , $I>>>$ (phases) $I_{E>}$ , $I_{E>>}$ , $I_{E>>>}$ (earth)
Setting ranges	
Pickup phase elements	0.5 to 175 A or $\infty^1$ (in steps of 0.01 A)
Pickup earth elements	0.25 to 175 A or $\infty^1$ (in steps of 0.01 A)
Delay times $T$	0 to 60 s or $\infty$ (in steps of 0.01 s)
Dropout delay time $T_{DO}$	0 to 60 s (in steps of 0.01 s)
Times	
Pickup times (without inrush restraint, with inrush restraint + 10 ms)	
With twice the setting value	Approx. 30 ms
With five times the setting value	Approx. 20 ms
Dropout times	Approx. 40 ms
Dropout ratio	Approx. 0.95 for $I/I_{nom} \geq 0.3$
Tolerances	
Pickup	2 % of setting value or 50 mA <sup>1)</sup>
Delay times $T$ , $T_{DO}$	1 % or 10 ms

**Inverse-time overcurrent protection (ANSI 51, 51N)**

Operating mode phase protection (ANSI 51)	3-phase (standard) or 2-phase (L1 and L3)
Setting ranges	
Pickup phase element $I_p$	0.5 to 20 A or $\infty^1$ (in steps of 0.01 A)
Pickup earth element $I_{EP}$	0.25 to 20 A or $\infty^1$ (in steps of 0.01 A)
Time multiplier $T$ (IEC characteristics)	0.05 to 3.2 s or $\infty$ (in steps of 0.01 s)
Time multiplier $D$ (ANSI characteristics)	0.05 to 15 s or $\infty$ (in steps of 0.01 s)
Trip characteristics	
IEC	Normal inverse, very inverse, extremely inverse, long inverse
ANSI	Inverse, short inverse, long inverse moderately inverse, very inverse, extremely inverse, definite inverse
User-defined characteristic	Defined by a maximum of 20 value pairs of current and time delay
Dropout setting	
Without disk emulation	Approx. $1.05 \cdot$ setting value $I_p$ for $I_p/I_{nom} \geq 0.3$ , corresponds to approx. $0.95 \cdot$ pickup threshold
With disk emulation	Approx. $0.90 \cdot$ setting value $I_p$
Tolerances	
Pickup/dropout thresholds $I_p$ , $I_{EP}$	2 % of setting value or 50 mA <sup>1)</sup>
Pickup time for $2 \leq I/I_p \leq 20$	5 % of reference (calculated) value + 2 % current tolerance, respectively 30 ms
Dropout ratio for $0.05 \leq I/I_p \leq 0.9$	5 % of reference (calculated) value + 2 % current tolerance, respectively 30 ms

1) For  $I_{nom} = 1$  A, all limits divided by 5.**Inrush blocking**

Influenced functions	Time-overcurrent elements, $I>$ , $I_{E>}$ , $I_p$ , $I_{EP}$
Lower function limit phases	At least one phase current (50 Hz and 100 Hz) $\geq 125$ mA <sup>1)</sup>
Lower function limit earth	Earth current (50 Hz and 100 Hz) $\geq 125$ mA <sup>1)</sup>
Upper function limit (setting range)	1.5 to 125 A <sup>1)</sup> (in steps of 0.01 A)
Setting range $I_{2f}/I$	10 to 45 % (in steps of 1 %)
Crossblock ( $I_{L1}$ , $I_{L2}$ , $I_{L3}$ )	ON/OFF

**Dynamic setting change**

Controllable function	Pickup, tripping time
Start criteria	Current criteria, CB position via aux. contacts, binary input, auto-reclosure ready
Time control	3 timers
Current criteria	Current threshold (reset on dropping below threshold; monitoring with timer)

**(Sensitive) earth-fault detection (ANSI 50Ns, 51Ns)****Earth-fault pickup for all types of earth faults****Definite-time characteristic (ANSI 50Ns)**

Setting ranges	
Pickup threshold $I_{EE>}$ , $I_{EE>>}$	
For sensitive input	0.001 to 1.5 A (in steps of 0.001 A)
For normal input	0.25 to 175 A <sup>1)</sup> (in steps of 0.01 A)
Delay times $T$ for $I_{EE>}$ , $I_{EE>>}$	0 to 320 s or $\infty$ (in steps of 0.01 s)
Dropout delay time $T_{DO}$	0 to 60 s (in steps of 0.01 s)

Times	
Pickup times	Approx. 50 ms

Dropout ratio	Approx. 0.95
---------------	--------------

Tolerances	
Pickup threshold $I_{EE>}$ , $I_{EE>>}$	2 % of setting value or 1 mA
Delay times	1 % of setting value or 20 ms

**Earth-fault pickup for all types of earth faults****Inverse-time characteristic (ANSI 51Ns)**

User-defined characteristic	Defined by a maximum of 20 pairs of current and delay time values
-----------------------------	---

Setting ranges	
Pickup threshold $I_{EEP}$	
For sensitive input	0.001 A to 1.4 A (in steps of 0.001 A)
For normal input	0.25 to 20 A <sup>1)</sup> (in steps of 0.01 A)
User defined	
Time multiplier $T$	0.1 to 4 s or $\infty$ (in steps of 0.01 s)

Times	
Pickup times	Approx. 50 ms

Pickup threshold	Approx. $1.1 \cdot I_{EEP}$
------------------	-----------------------------

Dropout ratio	Approx. $1.05 \cdot I_{EEP}$
---------------	------------------------------

Tolerances	
Pickup threshold	
For sensitive input	2 % of setting value or 1 mA
For normal input	2 % of setting value or 50 mA <sup>1)</sup>
Dropout times in linear range	7 % of reference value for $2 \leq I/I_{EEP} \leq 20$ + 2 % current tolerance, or 70 ms

**Logarithmic inverse**

Refer to the manual

**Logarithmic inverse with knee point**

Refer to the manual

## Technical data

**High-impedance restricted earth-fault protection (ANSI 87N) / single-phase overcurrent protection**

Setting ranges	
Pickup thresholds $I_{>}, I_{>>}$	
For sensitive input	0.003 to 1.5 A or $\infty$ (in steps of 0.001 A)
For normal input	0.25 to 175 A <sup>1)</sup> or $\infty$ (in steps of 0.01 A)
Delay times $T_{I>}, T_{I>>}$	0 to 60 s or $\infty$ (in steps of 0.01 s)
Times	
Pickup times	
Minimum	Approx. 20 ms
Typical	Approx. 30 ms
Dropout times	Approx. 30 ms
Dropout ratio	Approx. 0.95 for $I/I_{nom} \geq 0.5$
Tolerances	
Pickup thresholds	3 % of setting value or 1 % rated current at $I_{nom} = 1$ or 5 A; 5 % of setting value or 3 % rated current at $I_{nom} = 0.1$ A
Delay times	1 % of setting value or 10 ms

**Intermittent earth-fault protection**

Setting ranges	
Pickup threshold	
For $I_E$	$I_{IE>}$ 0.25 to 175 A <sup>1)</sup> (in steps of 0.01 A)
For $3I_0$	$I_{IE>}$ 0.25 to 175 A <sup>1)</sup> (in steps of 0.01 A)
For $I_{EE}$	$I_{IE>}$ 0.005 to 1.5 A (in steps of 0.001 A)
Pickup prolon- gation time	$T_V$ 0 to 10 s (in steps of 0.01 s)
Earth-fault accu- mulation time	$T_{sum}$ 0 to 100 s (in steps of 0.01 s)
Reset time for accumulation	$T_{res}$ 1 to 600 s (in steps of 1 s)
Number of pickups for intermittent earth fault	2 to 10 (in steps of 1)
Times	
Pickup times	
Current = 1.25 · pickup value	Approx. 30 ms
Current $\geq 2 \cdot$ pickup value	Approx. 22 ms
Dropout time	Approx. 22 ms
Tolerances	
Pickup threshold $I_{IE>}$	3 % of setting value, or 50 mA <sup>1)</sup>
Times $T_V, T_{sum}, T_{res}$	1 % of setting value or 10 ms

**Thermal overload protection (ANSI 49)**

Setting ranges	
Factor k	0.1 to 4 (in steps of 0.01)
Time constant	1 to 999.9 min (in steps of 0.1 min)
Warning overtemperature $\Theta_{alarm}/\Theta_{trip}$	50 to 100 % with reference to the tripping overtemperature (in steps of 1 %)
Current warning stage $I_{alarm}$	0.5 to 20 A (in steps of 0.01 A)
Extension factor when stopped $k_T$ factor	1 to 10 with reference to the time constant with the machine running (in steps of 0.1)
Rated overtemperature (for $I_{nom}$ )	40 to 200 °C (in steps of 1 °C)

1) For  $I_{nom} = 1$  A, all limits divided by 5.Tripping characteristic  
For  $(I/k \cdot I_{nom}) \leq 8$ 

$$t = \tau_{th} \cdot \ln \frac{(I/k \cdot I_{nom})^2 - (I_{pre}/k \cdot I_{nom})^2}{(I/k \cdot I_{nom})^2 - 1}$$

$t$  = Tripping time  
 $\tau_{th}$  = Temperature rise time constant

$I$  = Load current  
 $I_{pre}$  = Preload current  
 $k$  = Setting factor acc. to VDE 0435

Part 3011 and IEC 60255-8  
 $I_{nom}$  = Rated (nominal) current of the  
protection relay

Dropout ratios

$\Theta/\Theta_{Trip}$   
 $\Theta/\Theta_{Alarm}$   
 $I/I_{Alarm}$

Drops out with  $\Theta_{Alarm}$   
Approx. 0.99  
Approx. 0.97

Tolerances

With reference to  $k \cdot I_{nom}$   
With reference to tripping time

Class 5 acc. to IEC 60255-8  
5 % +/- 2 s acc. to IEC 60255-8

**Auto-reclosure (ANSI 79)**

Number of reclosures	0 to 9 Shot 1 to 4 individually adjustable
Program for phase fault Start-up by	Time-overcurrent elements, negative sequence, binary input
Program for earth fault Start-up by	Time-overcurrent elements, sensitive earth-fault protection, binary input
Blocking of ARC	Pickup of protection functions, three-phase fault detected by a protec- tive element, binary input, last TRIP command after the reclosing cycle is complete (unsuccessful reclosing), TRIP command by the breaker failure protection (50BF), opening the CB without ARC initiation, external CLOSE command
Setting ranges	
Dead time (separate for phase and earth and individual for shots 1 to 4)	0.01 to 320 s (in steps of 0.01 s)
Blocking duration for manual- CLOSE detection	0.5 s to 320 s or 0 (in steps of 0.01 s)
Blocking duration after reclosure	0.5 s to 320 s (in steps of 0.01 s)
Blocking duration after dynamic blocking	0.01 to 320 s (in steps of 0.01 s)
Start-signal monitoring time	0.01 to 320 s or $\infty$ (in steps of 0.01 s)
Circuit-breaker supervision time	0.1 to 320 s (in steps of 0.01 s)
Max. delay of dead-time start	0 to 1800 s or $\infty$ (in steps of 0.1 s)
Maximum dead time extension	0.5 to 320 s or $\infty$ (in steps of 0.01 s)
Action time	0.01 to 320 s or $\infty$ (in steps of 0.01 s)

The delay times of the following protection function can be altered individ-  
ually by the ARC for shots 1 to 4(setting value  $T = T$ , non-delayed  $T = 0$ , blocking  $T = \infty$ ):

$I_{>>>}, I_{>}, I_{>>}, I_{I>}, I_{I>>}, I_{I>>>}, I_{E>}, I_{E>>}, I_{E>>>}, I_{Ep}$

## Technical data

**Auto-reclosure (ANSI 79) (cont'd)**

Additional functions	Lockout (final trip), delay of dead-time start via binary input (monitored), dead-time extension via binary input (monitored), co-ordination with other protection relays, circuit-breaker monitoring, evaluation of the CB contacts
----------------------	---

**Breaker failure protection (ANSI 50 BF)**

Setting ranges	
Pickup thresholds	0.2 to 5 A <sup>1)</sup> (in steps of 0.01 A)
Delay time	0.06 to 60 s or ∞ (in steps of 0.01 s)
Times	
Pickup times	
with internal start	is contained in the delay time
with external start	is contained in the delay time
Dropout times	Approx. 25 ms
Tolerances	
Pickup value	2 % of setting value (50 mA) <sup>1)</sup>
Delay time	1 % or 20 ms

**Flexible protection functions (ANSI 47, 50, 50N)**

Operating modes/measuring quantities	
3-phase	$I_1, I_2, I_2/I_1, 3I_0$
1-phase	$I, I_E, I_E$ sens.
Without fixed phase relation	Binary input
Pickup when	Exceeding or falling below threshold value
Setting ranges	
Current $I, I_1, I_2, 3I_0, I_E$	0.15 to 200 A <sup>1)</sup> (in steps of 0.01 A)
Current ratio $I_2 / I_1$	15 to 100 % (in steps of 1 %)
Sensitive earth current $I_{E \text{ sens.}}$	0.001 to 1.5 A (in steps of 0.001 A)
Dropout ratio >- stage	1.01 to 3 (in steps of 0.01)
Dropout ratio <- stage	0.7 to 0.99 (in steps of 0.01)
Pickup delay time	0 to 60 s (in steps of 0.01 s)
Trip delay time	0 to 3600 s (in steps of 0.01 s)
Dropout delay time	0 to 60 s (in steps of 0.01 s)
Times	
Pickup times, phase quantities	
With 2 times the setting value	Approx. 30 ms
With 10 times the setting value	Approx. 20 ms
Pickup times, symmetrical components	
With 2 times the setting value	Approx. 40 ms
With 10 times the setting value	Approx. 30 ms
Binary input	Approx. 20 ms
Dropout times	
Phase quantities	< 20 ms
Symmetrical components	< 30 ms
Binary input	< 10 ms
Tolerances	
Pickup threshold	
Phase quantities	1 % of setting value or 50 mA <sup>1)</sup>
Symmetrical components	2 % of setting value or 100 mA <sup>1)</sup>
Times	1 % of setting value or 10 ms

**Negative-sequence current detection (ANSI 46)****Definite-time characteristic (ANSI 46-1 and 46-2)**

Setting ranges	
Pickup current $I_{2>}, I_{2>>}$	0.5 to 15 A or ∞ (in steps of 0.01 A)
Delay times	0 to 60 s or ∞ (in steps of 0.01 s)
Dropout delay time $T_{DO}$	0 to 60 s (in steps of 0.01 s)
Functional limit	All phase currents $\leq 50 \text{ A}^{1)}$

Times	
Pickup times	Approx. 35 ms
Dropout times	Approx. 35 ms
Dropout ratio	Approx. 0.95 for $I_2 / I_{\text{nom}} > 0.3$
Tolerances	
Pickup thresholds	3 % of the setting value or 50 mA <sup>1)</sup>
Delay times	1 % or 10 ms
<b>Inverse-time characteristic (ANSI 46-TOC)</b>	
Setting ranges	
Pickup current	0.5 to 10 A <sup>1)</sup> (in steps of 0.01 A)
Time multiplier T (IEC characteristics)	0.05 to 3.2 s or ∞ (in steps of 0.01 s)
Time multiplier D (ANSI characteristics)	0.5 to 15 s or ∞ (in steps of 0.01 s)
Functional limit	All phase currents $\leq 50 \text{ A}^{1)}$
Trip characteristics	
IEC	Normal inverse, very inverse, extremely inverse
ANSI	Inverse, moderately inverse, very inverse, extremely inverse
Pickup threshold	Approx. $1.1 \cdot I_{2p}$ setting value
Dropout	
IEC and ANSI (without disk emulation)	Approx. $1.05 \cdot I_{2p}$ setting value, which is approx. $0.95 \cdot$ pickup threshold
ANSI with disk emulation	Approx. $0.90 \cdot I_{2p}$ setting value
Tolerances	
Pickup threshold	3 % of the setting value or 50 mA <sup>1)</sup>
Time for $2 \leq M \leq 20$	5 % of setpoint (calculated) +2 % current tolerance, at least 30 ms

**Starting time monitoring for motors (ANSI 48)**

Setting ranges	
Motor starting current $I_{\text{STARTUP}}$	2.5 to 80 A <sup>1)</sup> (in steps of 0.01)
Pickup threshold $I_{\text{MOTOR START}}$	2 to 50 A <sup>1)</sup> (in steps of 0.01)
Permissible starting time $T_{\text{STARTUP, cold motor}}$	1 to 180 s (in steps of 0.1 s)
Permissible starting time $T_{\text{STARTUP, warm motor}}$	0.5 to 180 s (in steps of 0.1 s)
Temperature threshold cold motor	0 to 80 % (in steps of 1 %)
Permissible blocked rotor time $T_{\text{LOCKED-ROTOR}}$	0.5 to 120 s or ∞ (in steps of 0.1 s)
Tripping time characteristic	
For $I > I_{\text{MOTOR START}}$	$t = \left( \frac{I_{\text{STARTUP}}}{I} \right)^2 \cdot T_{\text{STARTUP}}$
	$I_{\text{STARTUP}}$ = Rated motor starting current $I$ = Actual current flowing $T_{\text{STARTUP}}$ = Tripping time for rated motor starting current $t$ = Tripping time in seconds
Dropout ratio $I_{\text{MOTOR START}}$	Approx. 0.95
Tolerances	
Pickup threshold	2 % of setting value or 50 mA <sup>1)</sup>
Delay time	5 % or 30 ms

**Load jam protection for motors (ANSI 51M)**

Setting ranges	
Current threshold for alarm and trip	0.25 to 60 A <sup>1)</sup> (in steps of 0.01 A)
Delay times	0 to 600 s (in steps of 0.01 s)
Blocking duration after close signal detection	0 to 600 s (in steps of 0.01 s)
Tolerances	
Pickup threshold	2 % of setting value or 50 mA <sup>1)</sup>
Delay time	1 % of setting value or 10 ms

1) At  $I_{\text{nom}} = 1 \text{ A}$ , all limits divided by 5.

## Technical data

## Restart inhibit for motors (ANSI 66)

## Setting ranges

Motor starting current relative to rated motor current $I_{MOTOR\ START}/I_{Motor\ Nom}$	1.1 to 10 (in steps of 0.1)
Rated motor current $I_{Motor\ Nom}$	1 to 6 A <sup>1)</sup> (in steps of 0.01 A)
Max. permissible starting time $T_{Start\ Max}$	1 to 320 s (in steps of 1 s)
Equilibrium time $T_{Equal}$	0 min to 320 min (in steps of 0.1 min)
Minimum inhibit time $T_{MIN.\ INHIBIT\ TIME}$	0.2 min to 120 min (in steps of 0.1 min)
Max. permissible number of warm starts	1 to 4 (in steps of 1)
Difference between cold and warm starts	1 to 2 (in steps of 1)
Extension k-factor for cooling simulations of rotor at zero speed $k_{\tau\ at\ STOP}$	0.2 to 100 (in steps of 0.1)
Extension factor for cooling time constant with motor running $k_{\tau\ RUNNING}$	0.2 to 100 (in steps of 0.1)

## Restarting limit

$$\Theta_{restart} = \Theta_{rot\ max\ perm} \cdot \frac{n_c - 1}{n_c}$$

$\Theta_{restart}$  = Temperature limit below which restarting is possible

$\Theta_{rot\ max\ perm}$  = Maximum permissible rotor overtemperature (= 100 % in operational measured value  $\Theta_{rot}/\Theta_{rot\ trip}$ )

$n_c$  = Number of permissible start-ups from cold state

## Undercurrent monitoring (ANSI 37)

Signal from the operational measured values	Predefined with programmable logic
---	------------------------------------

## Temperature monitoring box (ANSI 38)

Temperature detectors	
Connectable boxes	1 or 2
Number of temperature detectors per box	Max. 6
Type of measuring	Pt 100 $\Omega$ or Ni 100 $\Omega$ or Ni 120 $\Omega$
Mounting identification	"Oil" or "Environment" or "Stator" or "Bearing" or "Other"

## Thresholds for indications

For each measuring detector	
Stage 1	-50 °C to 250 °C (in steps of 1 °C) -58 °F to 482 °F (in steps of 1 °F) or $\infty$ (no indication)
Stage 2	-50 °C to 250 °C (in steps of 1 °C) -58 °F to 482 °F (in steps of 1 °F) or $\infty$ (no indication)

1) At rated frequency.

## Additional functions

## Operational measured values

Currents $I_{L1}, I_{L2}, I_{L3}$	In A (kA) primary, in A secondary or in % $I_{nom}$
Positive-sequence component $I_1$	
Negative-sequence component $I_2$	
$I_E$ or $3I_0$	
Range Tolerance <sup>1)</sup>	10 to 200 % $I_{nom}$ 1 % of measured value or 0.5 % $I_{nom}$
Temperature overload protection $\Theta/\Theta_{Trip}$	In %
Range Tolerance <sup>1)</sup>	0 to 400 % 5 % class accuracy per IEC 60255-8
Temperature restart inhibit $\Theta_L/\Theta_{L\ Trip}$	In %
Range Tolerance <sup>1)</sup>	0 to 400 % 5 % class accuracy per IEC 60255-8
Restart threshold $\Theta_{Restart}/\Theta_{L\ Trip}$	In %
Reclose time $T_{Reclose}$	In min
Current of sensitive ground fault detection $I_{EE}$	In A (kA) primary and in mA secondary
Range Tolerance <sup>1)</sup>	0 mA to 1600 mA 2 % of measured value or 1 mA
RTD-box	See section "Temperature monitoring box"

## Long-term averages

Time window	5, 15, 30 or 60 minutes
Frequency of updates	Adjustable
Long-term averages of currents	$I_{L1dmd}, I_{L2dmd}, I_{L3dmd}, I_{1dmd}$ in A (kA)

## Max. / Min. report

Report of measured values	With date and time
Reset, automatic	Time of day adjustable (in minutes, 0 to 1439 min) Time frame and starting time adjustable (in days, 1 to 365 days, and $\infty$ )
Reset, manual	Using binary input, using keypad, via communication
Min./Max. values for current	$I_{L1}, I_{L2}, I_{L3}$ $I_1$ (positive-sequence component)
Min./Max. values for overload protection	$\Theta/\Theta_{Trip}$
Min./Max. values for mean values	$I_{L1dmd}, I_{L2dmd}, I_{L3dmd}$ $I_1$ (positive-sequence component)

## Local measured values monitoring

Current asymmetry	$I_{max}/I_{min} >$ balance factor, for $I > I_{balance\ limit}$
Current phase sequence	Clockwise (ABC) / counter-clockwise (ACB)
Limit value monitoring	Predefined limit values, user-defined expansions via CFC

## Fault recording

Recording of indications of the last 8 power system faults	
Recording of indications of the last 3 power system ground faults	

### Technical data

#### Time stamping

Resolution for event log (operational annunciations)	1 ms
Resolution for trip log (fault annunciations)	1 ms
Maximum time deviation (internal clock)	0.01 %
Battery	Lithium battery 3 V/1 Ah, type CR 1/2 AA, message "Battery Fault" for insufficient battery charge

#### Oscillographic fault recording

Maximum 8 fault records saved, memory maintained by buffer battery in case of loss of power supply	
Recording time	Total 20 s Pre-trigger and post-fault recording and memory time adjustable
Sampling rate for 50 Hz	1 sample/1.25 ms (16 samples/cycle)
Sampling rate for 60 Hz	1 sample/1.04 ms (16 samples/cycle)

#### Statistics

Saved number of trips	Up to 9 digits
Number of automatic reclosing commands (segregated according to 1 <sup>st</sup> and $\geq 2^{\text{nd}}$ cycle)	Up to 9 digits

#### Circuit-breaker wear

Methods	<ul style="list-style-type: none"> <li>• <math>\Sigma I^x</math> with <math>x = 1 \dots 3</math></li> <li>• 2-point method (remaining service life)</li> <li>• <math>\Sigma I^2 t</math></li> </ul>
Operation	Phase-selective accumulation of measured values on TRIP command, up to 8 digits, phase-selective limit values, monitoring indication

#### Motor statistics

Total number of motor start-ups	0 to 9999	(resolution 1)
Total operating time	0 to 99999 h	(resolution 1 h)
Total down-time	0 to 99999 h	(resolution 1 h)
Ratio operating time/down-time	0 to 100 %	(resolution 0.1 %)
Motor start-up data:	of the last 5 start-ups	
– start-up time	0.30 s to 9999.99 s	(resolution 10 ms)
– start-up current (primary)	0 A to 1000 kA	(resolution 1 A)

#### Operating hours counter

Display range	Up to 7 digits
Criterion	Overshoot of an adjustable current threshold (BkrClosed $I_{\text{MIN}}$ )

#### Trip circuit monitoring

With one or two binary inputs

#### Commissioning aids

Phase rotation field check, operational measured values, circuit-breaker/switching device test, creation of a test measurement report

#### Clock

Time synchronization	DCF77/IRIG-B signal (telegram format IRIG-B000), binary input, communication
----------------------	--

#### Setting group switchover of the function parameters

Number of available setting groups	4 (parameter group A, B, C and D)
Switchover performed	Via keypad, DIGSI, system (SCADA) interface or binary input

#### Control

Number of switching units	Depends on the binary inputs and outputs
Interlocking	Programmable
Circuit-breaker signals	Feedback, close, open, intermediate position
Control commands	Single command / double command 1, 1 plus 1 common or 2 trip contacts
Programmable controller	CFC logic, graphic input tool
Local control	Control via menu, assignment of a function key
Remote control	Via communication interfaces, using a substation automation and control system (e.g. SICAM), DIGSI 4 (e.g. via modem)

#### CE conformity

This product is in conformity with the Directives of the European Communities on the harmonization of the laws of the Member States relating to electromagnetic compatibility (EMC Council Directive 89/336/EEC) and electrical equipment designed for use within certain voltage limits (Council Directive 73/23/EEC).

This unit conforms to the international standard IEC 60255, and the German standard DIN 57435/Part 303 (corresponding to VDE 0435/Part 303).

Further applicable standards: ANSI/IEEE C37.90.0 and C37.90.1.

The unit conforms to the international standard IEC 60255, and the German standard DIN 57435/Part 303 (corresponding to VDE 0435/Part 303).

This conformity is the result of a test that was performed by Siemens AG in accordance with Article 10 of the Council Directive complying with the generic standards EN 50081-2 and EN 50082-2 for the EMC Directive and standard EN 60255-6 for the "low-voltage Directive".

## Selection and ordering data

Description	Order No.
<b>7SJ61 multifunction protection relay</b>	<b>7SJ61□□ - □□□□□ - □□□□</b>
<i>Housing, binary inputs (BI) and outputs (BO)</i>	
Housing 1/3 19", 3 BI, 4 BO, 1 live status contact	0
Housing 1/3 19", 8 BI, 8 BO, 1 live status contact	1
Housing 1/3 19", 11 BI, 6 BO, 1 live status contact	2
<i>Measuring inputs (4 x I)</i>	
$I_{ph} = 1 A^{1)}$ , $I_e = 1 A^{1)}$ (min. = 0.05 A) Position 15 only with A	1
$I_{ph} = 1 A^{1)}$ , $I_e = sensitive$ (min. = 0.001 A) Position 15 only with B	2
$I_{ph} = 5 A^{1)}$ , $I_e = 5 A^{1)}$ (min. = 0.25 A) Position 15 only with A	5
$I_{ph} = 5 A^{1)}$ , $I_e = sensitive$ (min. = 0.001 A) Position 15 only with B	6
$I_{ph} = 5 A^{1)}$ , $I_e = 1 A^{1)}$ (min. = 0.05 A) Position 15 only with A	7
<i>Rated auxiliary voltage (power supply, indication voltage)</i>	
24 to 48 V DC, threshold binary input 19 DC <sup>3)</sup>	2
60 to 125 V DC <sup>2)</sup> , threshold binary input 19 DC <sup>3)</sup>	4
110 to 250 V DC <sup>2)</sup> , 115 to 230 V <sup>4)</sup> AC, threshold binary input 88 V DC <sup>3)</sup>	5
110 to 250 V DC <sup>2)</sup> , 115 to 230 V <sup>4)</sup> AC, threshold binary input 176 V DC <sup>3)</sup>	6
<i>Unit version</i>	
For panel surface mounting, 2 tier terminal top/bottom	B
For panel flush mounting, plug-in terminal (2/3 pin connector)	D
For panel flush mounting, screw-type terminal (direct connection/ring-type cable lugs)	E
<i>Region-specific default settings/function versions and language settings</i>	
Region DE, 50 Hz, IEC, language: German, selectable	A
Region World, 50/60 Hz, IEC/ANSI, language: English (GB), selectable	B
Region US, 60 Hz, ANSI, language: English (US), selectable	C
Region FR, 50/60 Hz, IEC/ANSI, language: French, selectable	D
Region World, 50/60 Hz, IEC/ANSI, language: Spanish, selectable	E
Region IT, 50/60 Hz, IEC/ANSI, language: Italian, selectable	F
<i>System interface (Port B): Refer to page 5/99</i>	
No system interface	0
Protocols see page 5/99	
<i>Service interface (Port C)</i>	
No interface at rear side	0
DIGSI 4/modem, electrical RS232	1
DIGSI 4/modem/RTD-box <sup>5)</sup> , electrical RS485	2
DIGSI 4/modem/RTD-box <sup>5)6)</sup> , optical 820 nm wavelength, ST connector	3
<i>Measuring/fault recording</i>	
Fault recording	1
Slave pointer, mean values, min/max values, fault recording	3

see  
next  
page

- 1) Rated current can be selected by means of jumpers.
- 2) Transition between the two auxiliary voltage ranges can be selected by means of jumpers.
- 3) The binary input thresholds can be selected per binary input by means of jumpers.
- 4) 230 V AC, starting from device version .../EE.
- 5) Temperature monitoring box 7XV5662-□AD10, refer to "Accessories".
- 6) When using the temperature monitoring box at an optical interface, the additional RS485 fiber-optic converter 7XV5650-0□A00 is required.

Selection and ordering data

Description			Order No.	Order code
<i>7SJ61 multifunction protection relay</i>			<i>7SJ61□□ - □□□□□ - □□□□ - □□□□</i>	
Designation	ANSI No.	Description		
Basic version		Control		
	50/51	Time-overcurrent protection $I>$ , $I>>$ , $I>>>$ , $I_p$		
	50N/51N	Earth-fault protection $I_{E>}$ , $I_{E>>}$ , $I_{E>>>}$ , $I_{Ep}$		
	50N/51N	Earth-fault protection via insensitive IEE function: $I_{EE>}$ , $I_{EE>>}$ , $I_{EEp}$ <sup>1)</sup>		
	50/50N	Flexible protection functions (index quantities derived from current): Additional time-overcurrent protection stages $I_{2>}$ , $I_{>>>>}$ , $I_{E>>>>}$		
	49	Overload protection (with 2 time constants)		
	46	Phase balance current protection (negative-sequence protection)		
	50BF	Breaker failure protection		
	37	Undercurrent monitoring		
	74TC	Trip circuit supervision		
		4 setting groups, cold-load pickup		
		Inrush blocking		
	86	Lockout	F	A
■	IEF	Intermittent earth fault	P	A
■	50Ns/51Ns	Sensitive earth-fault detection (non-directional)	F	B <sup>2)</sup>
	87N	High-impedance restricted earth fault		
■	IEF	Sensitive earth-fault detection (non-directional)	P	B <sup>2)</sup>
	87N	High-impedance restricted earth fault		
		Intermittent earth fault		
■	Motor IEF	Sensitive earth-fault detection (non-directional)	R	B <sup>2)</sup>
	87N	High-impedance restricted earth fault		
		Intermittent earth fault		
	48/14	Starting time supervision, locked rotor		
	66/86	Restart inhibit		
	51M	Load jam protection, motor statistics		
■	Motor	Sensitive earth-fault detection (non-directional)	H	B <sup>2)</sup>
	87N	High-impedance restricted earth fault		
	48/14	Starting time supervision, locked rotor		
	66/86	Restart inhibit		
	51M	Load jam protection, motor statistics		
■	Motor	Starting time supervision, locked rotor	H	A
	66/86	Restart inhibit		
	51M	Load jam protection, motor statistics		
ARC		Without	0	
	79	With auto-reclosure	1	
ATEX100 Certification				
For protection of explosion-protected motors (increased-safety type of protection "e")			Z	X 9 9 <sup>3)</sup>

■ Basic version included

IEF = Intermittent earth fault

1) 50N/51N only with insensitive earth-current transformer when position 7 = 1, 5, 7.

2) Sensitive earth-current transformer only when position 7 = 2, 6.

3) This variant might be supplied with a previous firmware version.

Order numbers for system port B

Description	Order No.	Order code
<i>7SJ61 multifunction protection relay</i>		
<i>7SJ61□□ - □□□□□ - □□□□□ - □□□□</i>		
<b>System interface (on rear of unit, Port B)</b>		
No system interface	0	
IEC 60870-5-103 protocol, RS232	1	
IEC 60870-5-103 protocol, RS485	2	
IEC 60870-5-103 protocol, 820 nm fiber, ST connector	3	
PROFIBUS-FMS Slave, RS485	4	
PROFIBUS-FMS Slave, 820 nm wavelength, single ring, ST connector <sup>1)</sup>	5	
PROFIBUS-FMS Slave, 820 nm wavelength, double ring, ST connector <sup>1)</sup>	6	
PROFIBUS-DP Slave, RS485	9	LOA
PROFIBUS-DP Slave, 820 nm wavelength, double ring, ST connector <sup>1)</sup>	9	LOB
MODBUS, RS485	9	LOD
MODBUS, 820 nm wavelength, ST connector <sup>2)</sup>	9	LOE
DNP 3.0, RS485	9	LOG
DNP 3.0, 820 nm wavelength, ST connector <sup>2)</sup>	9	LOH
IEC 60870-5-103 protocol, redundant, RS485, RJ45 connector <sup>2)</sup>	9	LOP
IEC 61850, 100 Mbit Ethernet, electrical, double, RSJ45 connector (EN 100)	9	LOR
IEC 61850, 100 Mbit Ethernet, optical, double, ST connector (EN 100) <sup>2)</sup>	9	LOS

- 1) Not with position 9 = "B"; if 9 = "B", please order 7SJ6 unit with RS485 port and separate fiber-optic converters.  
 For single ring, please order converter 6GK1502-3AB10, not available with position 9 = "B".  
 For double ring, please order converter 6GK1502-4AB10, not available with position 9 = "B".  
 The converter requires a 24 V AC power supply (e.g. power supply 7XV5810-0BA00).
- 2) Not available with position 9 = "B".

Sample order

Position	Order No. + Order code
<i>7SJ6125-5EC91-3FA1+LOG</i>	
6 I/O's: 11 BI/6 BO, 1 live status contact	2
7 Current transformer: 5 A	5
8 Power supply: 110 to 250 V DC, 115 V AC to 230 V AC	5
9 Unit version: Flush-mounting housing, screw-type terminals	E
10 Region: US, English language (US); 60 Hz, ANSI	C
11 Communication: System interface: DNP 3.0, RS485	9
12 Communication: DIGSI 4, electric RS232	1
13 Measuring/fault recording: Extended measuring and fault records	3
14/15 Protection function package: Basic version	FA
16 With auto-reclosure	1

5

## Accessories

Description	Order No.
<i>DIGSI 4</i>	
Software for configuration and operation of Siemens protection units running under MS Windows 2000/XP Professional Edition	
Basis	Full version with license for 10 computers, on CD-ROM (authorization by serial number) <span style="float: right;">7XS5400-0AA00</span>
Professional	DIGSI 4 Basis and additionally SIGRA (fault record analysis), CFC Editor (logic editor), Display Editor (editor for default and control displays) and DIGSI 4 Remote (remote operation) <span style="float: right;">7XS5402-0AA00</span>
Professional + IEC 61850	Complete version: DIGSI 4 Basis and additionally SIGRA (fault record analysis), CFC Editor (logic editor), Display Editor (editor for control displays), DIGSI 4 Remote (remote operation) + IEC 61850 system configurator <span style="float: right;">7XS5403-0AA00</span>
<i>IEC 61850 System configurator</i>	
Software for configuration of stations with IEC 61850 communication under DIGSI, running under MS Windows 2000 or XP Professional Edition Optional package for DIGSI 4 Basis or Professional License for 10 PCs. Authorization by serial number. On CD-ROM <span style="float: right;">7XS5460-0AA00</span>	
<i>SIGRA 4</i>	
Software for graphic visualization, analysis and evaluation of fault records. Can also be used for fault records of devices of other manufacturers (Comtrade format). Running under MS Windows 2000 or XP Professional Edition. (generally contained in DIGSI Professional, but can be ordered additionally) Authorization by serial number. On CD-ROM. <span style="float: right;">7XS5410-0AA00</span>	
<i>Temperature monitoring box</i>	
24 to 60 V AC/DC	<span style="float: right;">7XV5662-2AD10</span>
90 to 240 V AC/DC	<span style="float: right;">7XV5662-5AD10</span>
<i>Varistor/Voltage Arrester</i>	
Voltage arrester for high-impedance REF protection	
125 Vrms; 600 A; 1S/S 256	<span style="float: right;">C53207-A401-D76-1</span>
240 Vrms; 600 A; 1S/S 1088	<span style="float: right;">C53207-A401-D77-1</span>
<i>Connecting cable</i>	
Cable between PC/notebook (9-pin con.) and protection unit (9-pin connector) (contained in DIGSI 4, but can be ordered additionally) <span style="float: right;">7XV5100-4</span>	
Cable between temperature monitoring box and SIPROTEC 4 unit	
- length 5 m /16.4 ft	<span style="float: right;">7XV5103-7AA05</span>
- length 25 m /82 ft	<span style="float: right;">7XV5103-7AA25</span>
- length 50 m /164 ft	<span style="float: right;">7XV5103-7AA50</span>
<i>Manual for 7SJ61</i>	
English	<span style="float: right;">C53000-G1140-C118-x<sup>1)</sup></span>

1) x = please inquire for latest edition (exact Order No.).

## Accessories



Mounting rail

LSP2289-afp.eps

2-pin  
connector

LSP2090-afp.eps

3-pin  
connector

LSP2091-afp.eps

Short-circuit links  
for current termi-  
nals

LSP2093-afp.eps

Short-circuit links  
for other terminals

LSP2092-afp.eps

Description	Order No.	Size of package	Supplier
Terminal safety cover			
Voltage/current terminal 18-pole/12-pole	<a href="#">C73334-A1-C31-1</a>	1	Siemens
Voltage/current terminal 12-pole/8-pole	<a href="#">C73334-A1-C32-1</a>	1	Siemens
Connector 2-pin	<a href="#">C73334-A1-C35-1</a>	1	Siemens
Connector 3-pin	<a href="#">C73334-A1-C36-1</a>	1	Siemens
Crimp connector CI2 0.5 to 1 mm <sup>2</sup>	<a href="#">0-827039-1</a>	4000 taped on reel	AMP <sup>1)</sup>
Crimp connector CI2 0.5 to 1 mm <sup>2</sup>	<a href="#">0-827396-1</a>	1	AMP <sup>1)</sup>
Crimp connector: Type III+ 0.75 to 1.5 mm <sup>2</sup>	<a href="#">0-163084-2</a>	1	AMP <sup>1)</sup>
Crimp connector: Type III+ 0.75 to 1.5 mm <sup>2</sup>	<a href="#">0-163083-7</a>	4000 taped on reel	AMP <sup>1)</sup>
Crimping tool for Type III+ and matching female	<a href="#">0-539635-1</a>	1	AMP <sup>1)</sup>
	<a href="#">0-539668-2</a>	1	AMP <sup>1)</sup>
Crimping tool for CI2 and matching female	<a href="#">0-734372-1</a>	1	AMP <sup>1)</sup>
	<a href="#">1-734387-1</a>	1	AMP <sup>1)</sup>
Short-circuit links for current terminals	<a href="#">C73334-A1-C33-1</a>	1	Siemens
Short-circuit links for other terminals	<a href="#">C73334-A1-C34-1</a>	1	Siemens
Mounting rail for 19" rack	<a href="#">C73165-A63-D200-1</a>	1	Siemens

1) Your local Siemens representative  
can inform you on local suppliers.

Connection diagram

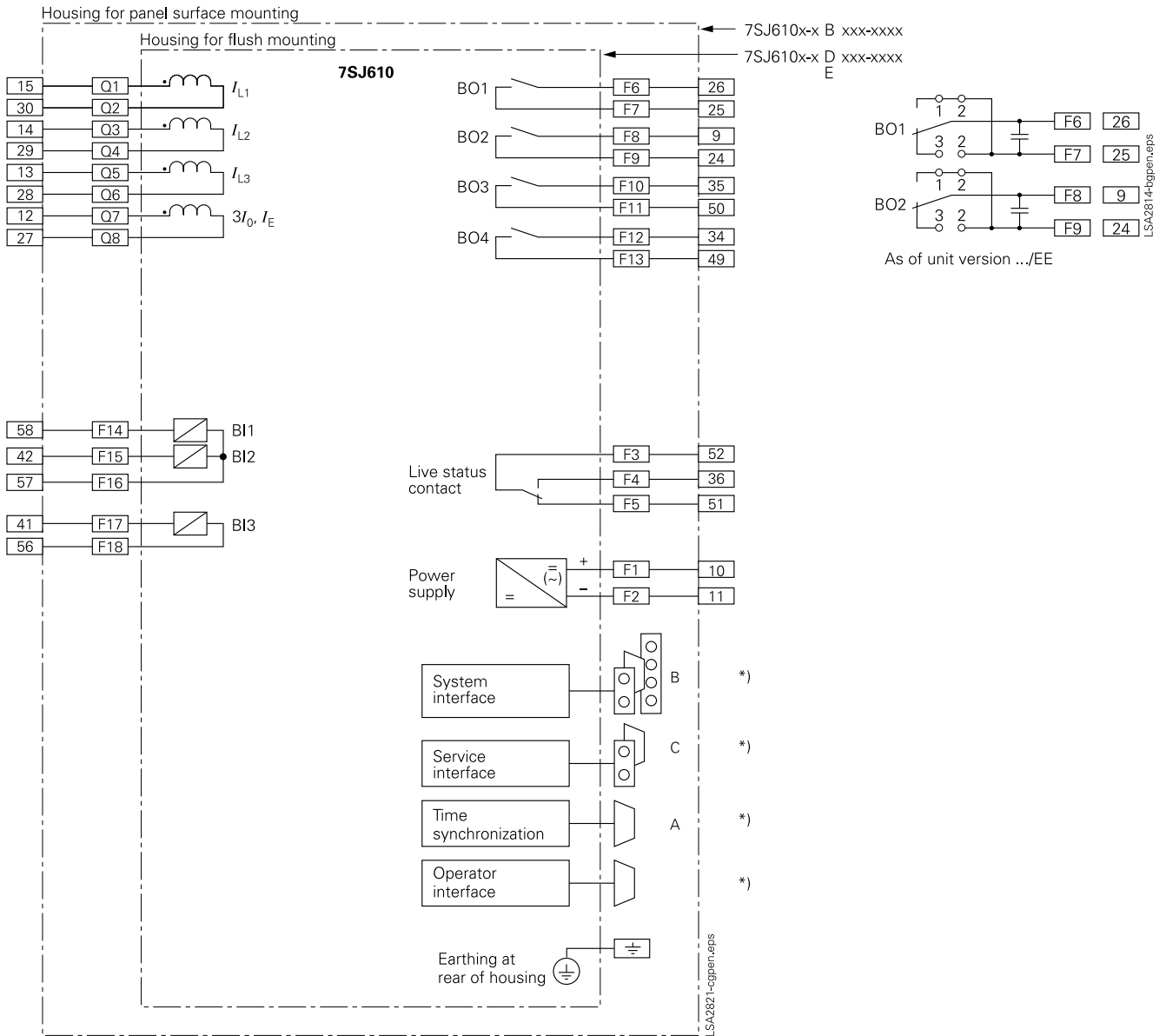

Fig. 5/94  
7SJ610 connection diagram

\*) For pinout of communication ports see part 17 of this catalog.  
For the allocation of the terminals of the panel surface-mounting version refer to the manual (<http://www.siprotec.com>).

Connection diagram

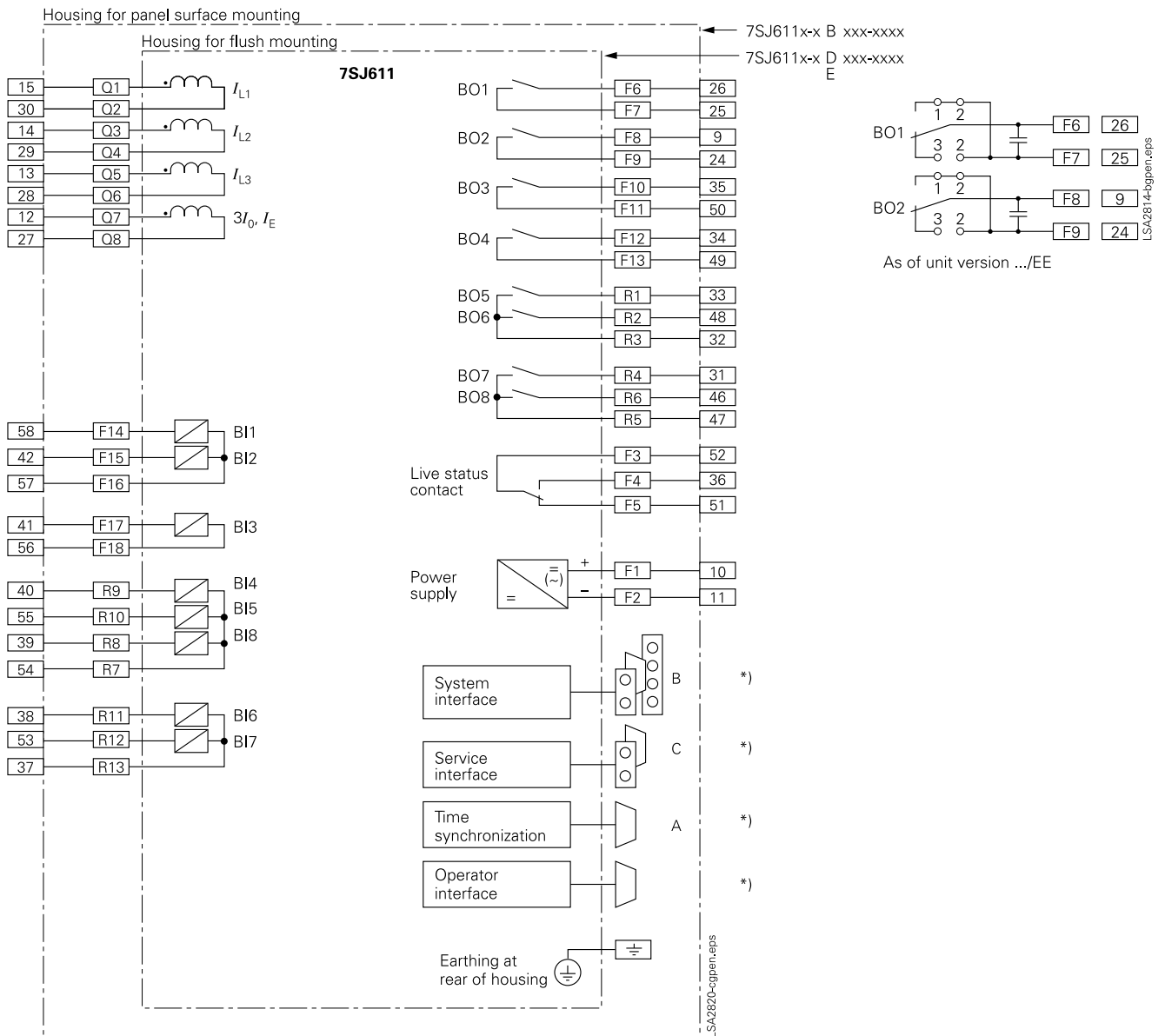

Fig. 5/95  
7SJ611 connection diagram

\*) For pinout of communication ports see part 17 of this catalog.  
For the allocation of the terminals of the panel surface-mounting version refer to the manual (<http://www.siprotec.com>).

Connection diagram

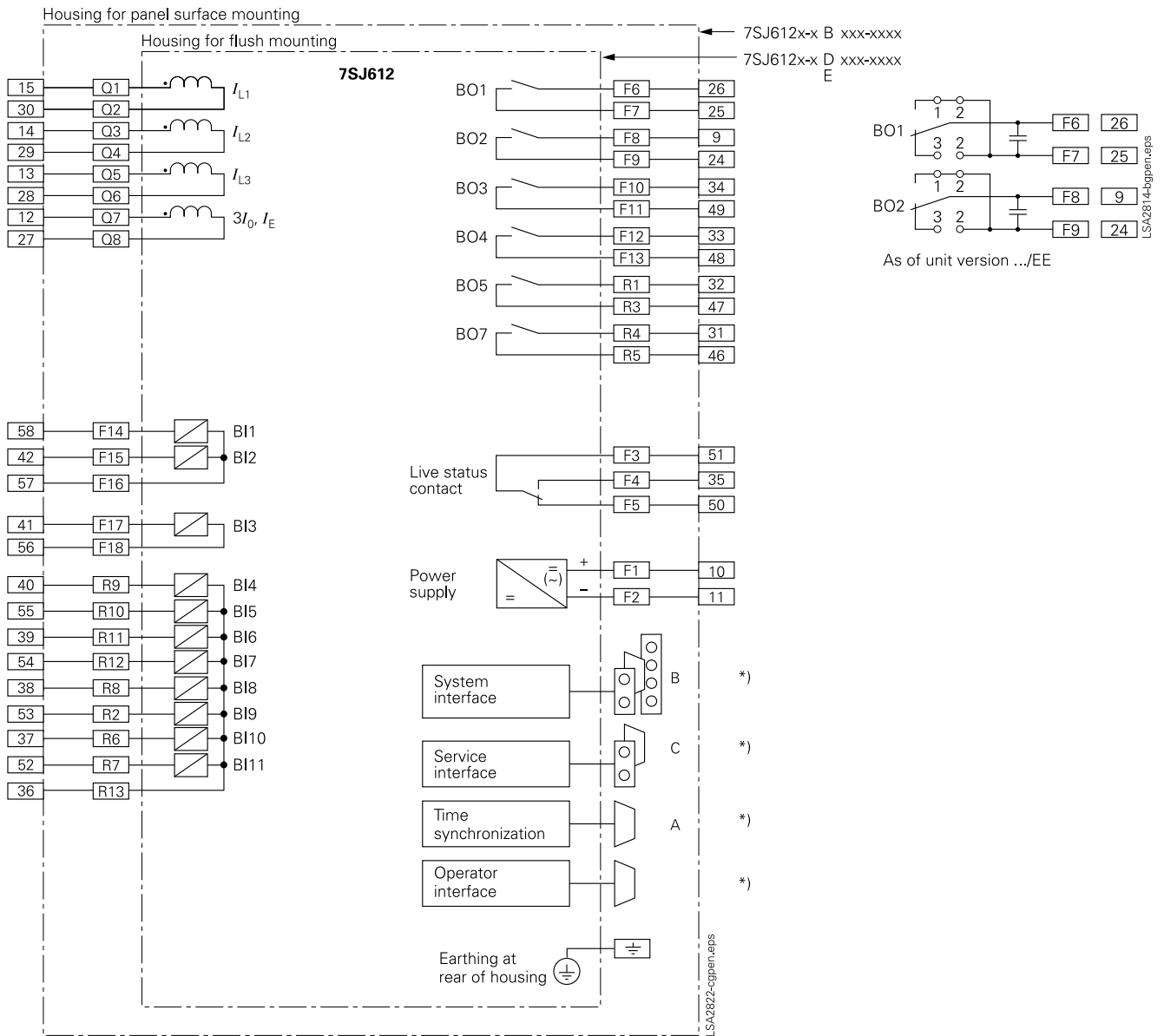

Fig. 5/96  
7SJ612 connection diagram

\*) For pinout of communication ports see part 17 of this catalog.  
For the allocation of the terminals of the panel surface-mounting version refer to the manual (<http://www.siprotec.com>).

Dimension drawings in mm / inch

Dimension drawings for SIPROTEC 4  
1/3 x 19" housing (7XP20)

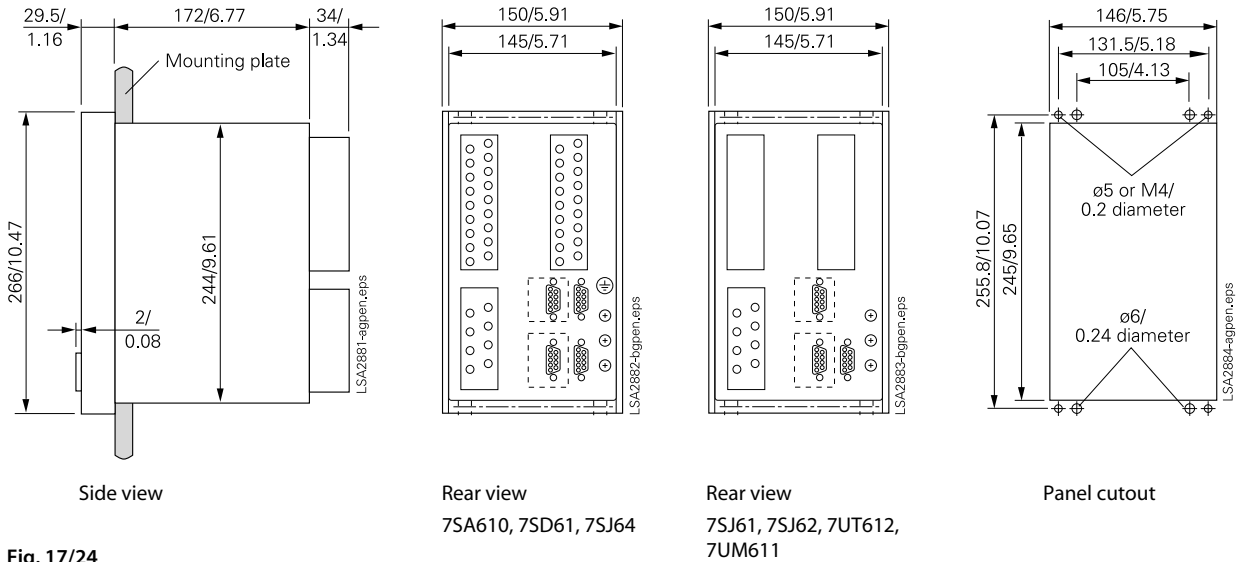

Fig. 17/24  
Housing for panel flush mounting/  
cubicle mounting (1/3 x 19")

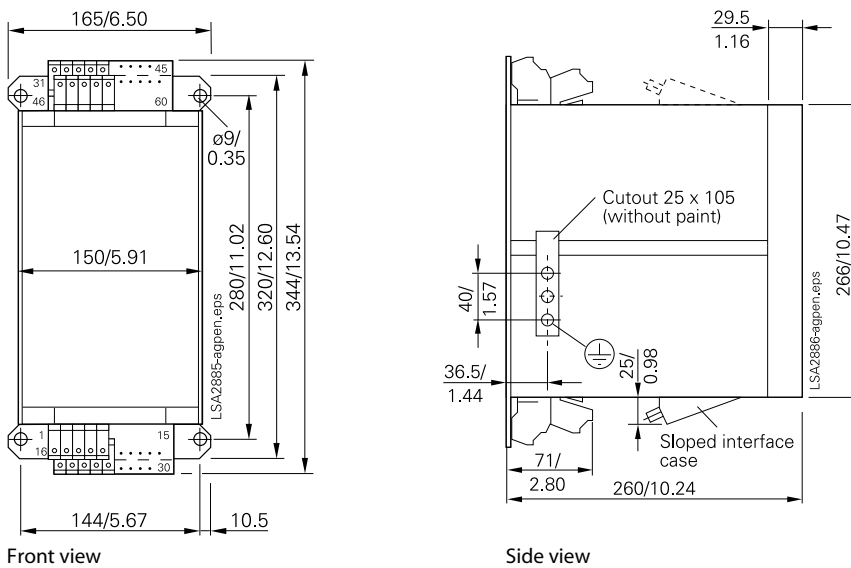

Fig. 17/25  
1/3 x 19" surface-mounting housing,  
terminals at top and bottom