



GRF18S-F234LV

GRF18S

OPTICAL LEVEL SWITCH

SICK
Sensor Intelligence.

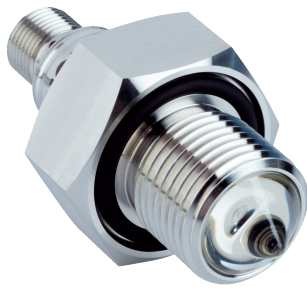

Ordering information

Type	Part no.
GRF18S-F234LV	1092958

Other models and accessories → www.sick.com/GRF18S



Detailed technical data

Features

Medium	Fluids
Measurement	Switch
Light source	LED
Type of light	Visible red light
Wave length	650 nm
Process pressure	-0.5 bar ... 20 bar
Process temperature	-10 °C ... +55 °C
UL approval	✓
RoHS certificate	✓

Performance

Response time	10 ms
MTBF	1178 a
MTTFd	2,304 years

Electronics

Supply voltage	10 V DC ... 30 V DC ¹⁾
Residual ripple	≤ 5 V _{pp} ²⁾
Power consumption	≤ 30 mA at 24 V DC without output load
Protection class	III
Connection type	M12 round connector x 1, 4-pin
Output signal	1 x PNP ³⁾
Switching mode	NO
Output current	≤ 100 mA ³⁾
Switching frequency	250 Hz ⁴⁾

¹⁾ U_V connections, reverse polarity protected.

²⁾ May not exceed or fall below U_V tolerances.

³⁾ Output overcurrent and short-circuit protected.

⁴⁾ With light/dark ratio 1:1.

Enclosure rating	IP67 / IP69
-------------------------	-------------

- 1) U_V connections, reverse polarity protected.
- 2) May not exceed or fall below U_V tolerances.
- 3) Output overcurrent and short-circuit protected.
- 4) With light/dark ratio 1:1.

Mechanics

Wetted parts	Stainless steel 316L, polysulfon, FPM
Process connection	G ½
Housing material	Stainless steel 1.4404

Ambient data

Ambient operating temperature	-10 °C ... +55 °C
Ambient temperature, storage	-25 °C ... +70 °C

Classifications

eCl@ss 5.0	27273204
eCl@ss 5.1.4	27273204
eCl@ss 6.0	27273204
eCl@ss 6.2	27273204
eCl@ss 7.0	27273204
eCl@ss 8.0	27273204
eCl@ss 8.1	27273204
eCl@ss 9.0	27273204
eCl@ss 10.0	27273204
eCl@ss 11.0	27273204
eCl@ss 12.0	27270919
ETIM 5.0	EC002654
ETIM 6.0	EC002654
ETIM 7.0	EC002654
ETIM 8.0	EC002654
UNSPSC 16.0901	41111950

Type code

Type code

Switching output

P	1 x PNP transistor output, normally closed
F	1 x PNP transistor output, normally open
E	1 x NPN transistor output, normally open
N	1 x NPN transistor output, normally closed

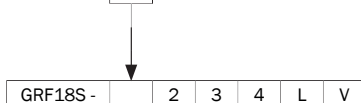

GRF18S-F234LV | GRF18S

OPTICAL LEVEL SWITCH

Dimensional drawing (Dimensions in mm (inch))

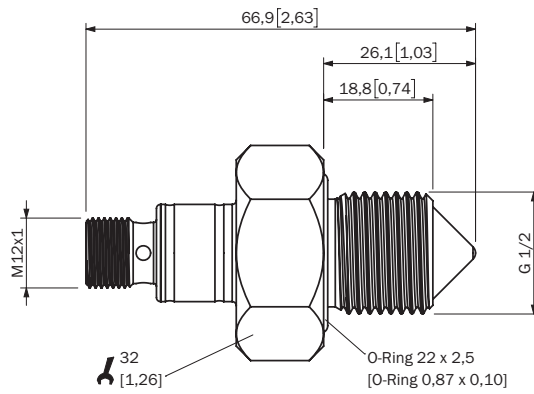

Application

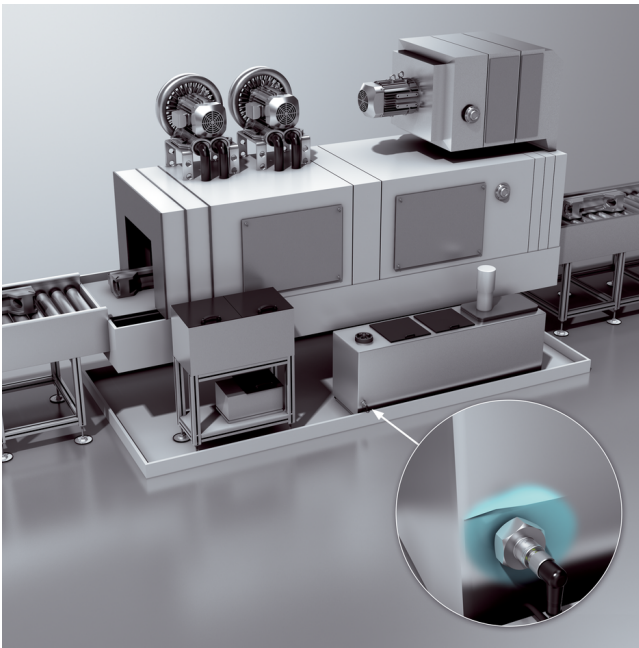

Connection diagram

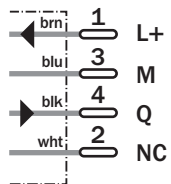

Connection type



Instruction for installation

Installation in containers

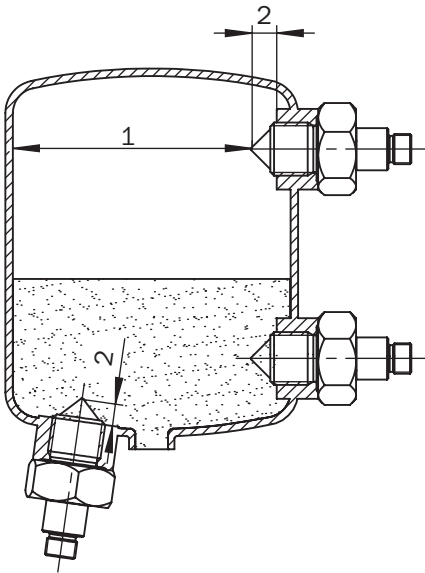

The apex should protrude into the container

- ① Distance ≥ 40 mm
- ② Filler tip = 8 mm

Installation in pipelines for pump dry-run protection

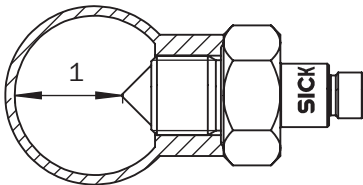

- ① Distance ≥ 40 mm

SICK AT A GLANCE

SICK is one of the leading manufacturers of intelligent sensors and sensor solutions for industrial applications. A unique range of products and services creates the perfect basis for controlling processes securely and efficiently, protecting individuals from accidents and preventing damage to the environment.

We have extensive experience in a wide range of industries and understand their processes and requirements. With intelligent sensors, we can deliver exactly what our customers need. In application centers in Europe, Asia and North America, system solutions are tested and optimized in accordance with customer specifications. All this makes us a reliable supplier and development partner.

Comprehensive services complete our offering: SICK LifeTime Services provide support throughout the machine life cycle and ensure safety and productivity.

For us, that is “Sensor Intelligence.”

WORLDWIDE PRESENCE:

Contacts and other locations –www.sick.com