



Overload relay 27...32 A size S0, class 10, for motor protection for mounting onto contactors main circuit: screw terminal AUX. circuit: screw terminal manual automatic reset

<b>product brand name</b>	SIRIUS
<b>product designation</b>	Thermal overload relay
<b>product type designation</b>	3RU6
<b>General technical data</b>	
<b>size of contactor can be combined company-specific</b>	S0
<b>power loss [W] total typical</b>	6.9 W
power loss [W] for rated value of the current at AC in hot operating state	9.6 W
• per pole	3.2 W
<b>type of calculation of power loss current-dependent</b>	quadratic
insulation voltage with degree of pollution 3 at AC rated value	690 V
<b>surge voltage resistance rated value</b>	6 kV
<b>shock resistance according to IEC 60068-2-27</b>	8 g / 11 ms
<b>Substance Prohibitance (day/month/year)</b>	05/01/2012
<b>Net Weight</b>	0.16 kg
<b>Ambient conditions</b>	
installation altitude at height above sea level maximum	2 000 m
<b>ambient temperature</b>	
• during operation	-40 ... +70 °C
• during transport	-55 ... +80 °C
relative humidity during operation	0 ... 90 %
<b>Main circuit</b>	
<b>number of poles for main current circuit</b>	3
<b>adjustable current response value current of the current-dependent overload release</b>	27 ... 32 A
operating voltage rated value	690 V
<b>operating frequency rated value</b>	50 ... 60 Hz
<b>operational current rated value</b>	32 A
<b>Auxiliary circuit</b>	
<b>operational current of auxiliary contacts at AC-15</b>	
• at 24 V	3 A
• at 230 V	2 A
<b>operational current of auxiliary contacts at DC-13</b>	
• at 24 V	2 A
• at 110 V	0.22 A
<b>Protective and monitoring functions</b>	
<b>trip class</b>	CLASS 10
<b>design of the overload release</b>	thermal
<b>Installation/ mounting/ dimensions</b>	

mounting position	any
fastening method	Contacteur mounting
height	85 mm
width	45 mm
depth	85 mm
required spacing for grounded parts at the side	6 mm

### Connections/ Terminals

<b>type of electrical connection</b> <ul style="list-style-type: none"> <li>• for main current circuit</li> <li>• for auxiliary and control circuit</li> </ul>	screw-type terminals screw-type terminals
<b>arrangement of electrical connectors for main current circuit</b>	Top and bottom
type of connectable conductor cross-sections for main contacts <ul style="list-style-type: none"> <li>• solid or stranded</li> <li>• finely stranded with core end processing</li> </ul>	2x (1 ... 2.5 mm <sup>2</sup> ), 2x (2.5 ... 10 mm <sup>2</sup> ) 2x (1 ... 2.5 mm <sup>2</sup> ), 2x (2.5 ... 6 mm <sup>2</sup> ), 1x 10 mm <sup>2</sup>
<b>type of connectable conductor cross-sections</b> <ul style="list-style-type: none"> <li>• for auxiliary contacts <ul style="list-style-type: none"> <li>— solid or stranded</li> <li>— finely stranded with core end processing</li> </ul> </li> <li>• for AWG cables for auxiliary contacts</li> </ul>	2x (0.5 ... 1.5 mm <sup>2</sup> ), 2x (0.75 ... 2.5 mm <sup>2</sup> ) 2x (0.5 ... 1.5 mm <sup>2</sup> ), 2x (0.75 ... 2.5 mm <sup>2</sup> ) 2x (20 ... 16), 2x (18 ... 14)
tightening torque for main contacts with screw-type terminals	2 ... 2.5 N·m

### Electrical Safety

<b>protection class IP on the front according to IEC 60529</b>	IP20
<b>touch protection on the front according to IEC 60529</b>	finger-safe, for vertical contact from the front

### Approvals Certificates

<b>General Product Approval</b>	<b>Maritime application</b>	<b>other</b>
---------------------------------	-----------------------------	--------------



[CCS \(China Classification Society\)](#)

[Confirmation](#)

<b>other</b>	<b>Environment</b>
--------------	--------------------



[Environmental Conformations](#)

### Further information

Service&Support (Manuals, Certificates, Characteristics, FAQs,...)  
<https://support.industry.siemens.com/cs/products?pnid=16027&lc=en-CN>

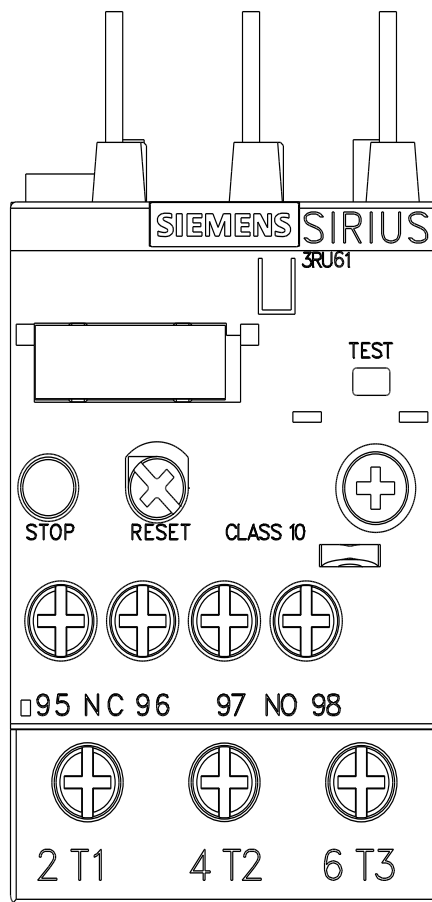
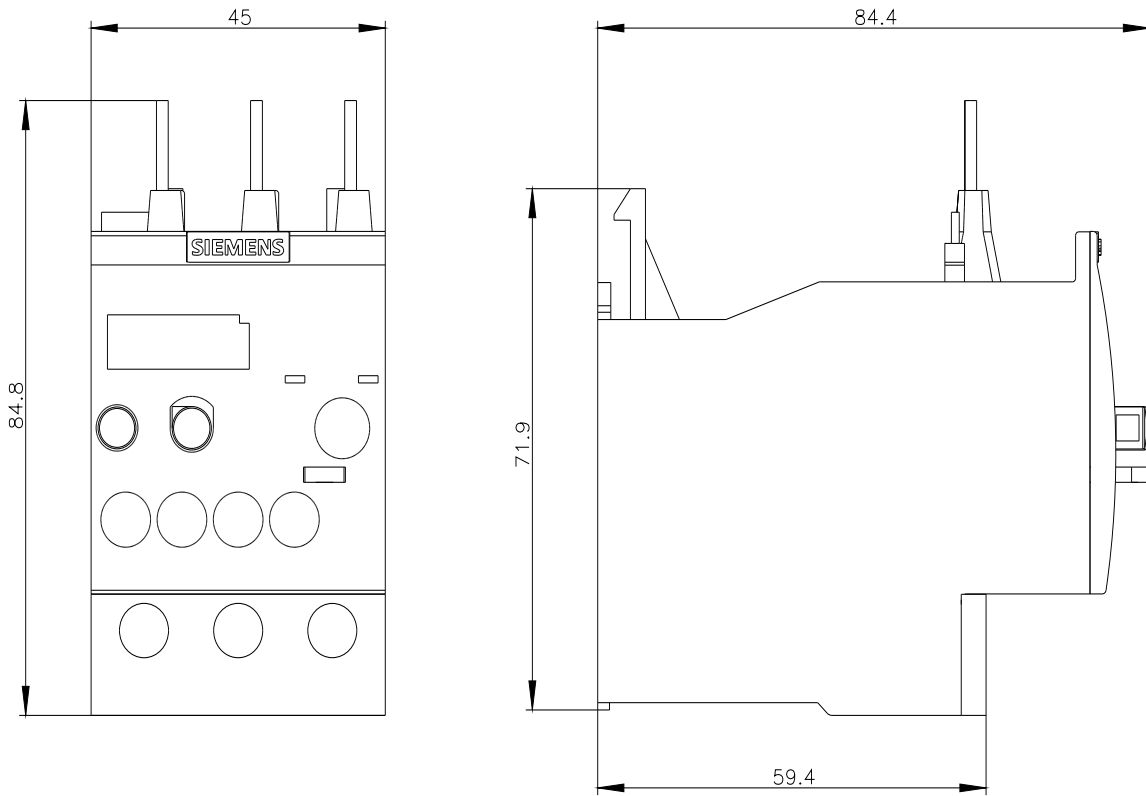

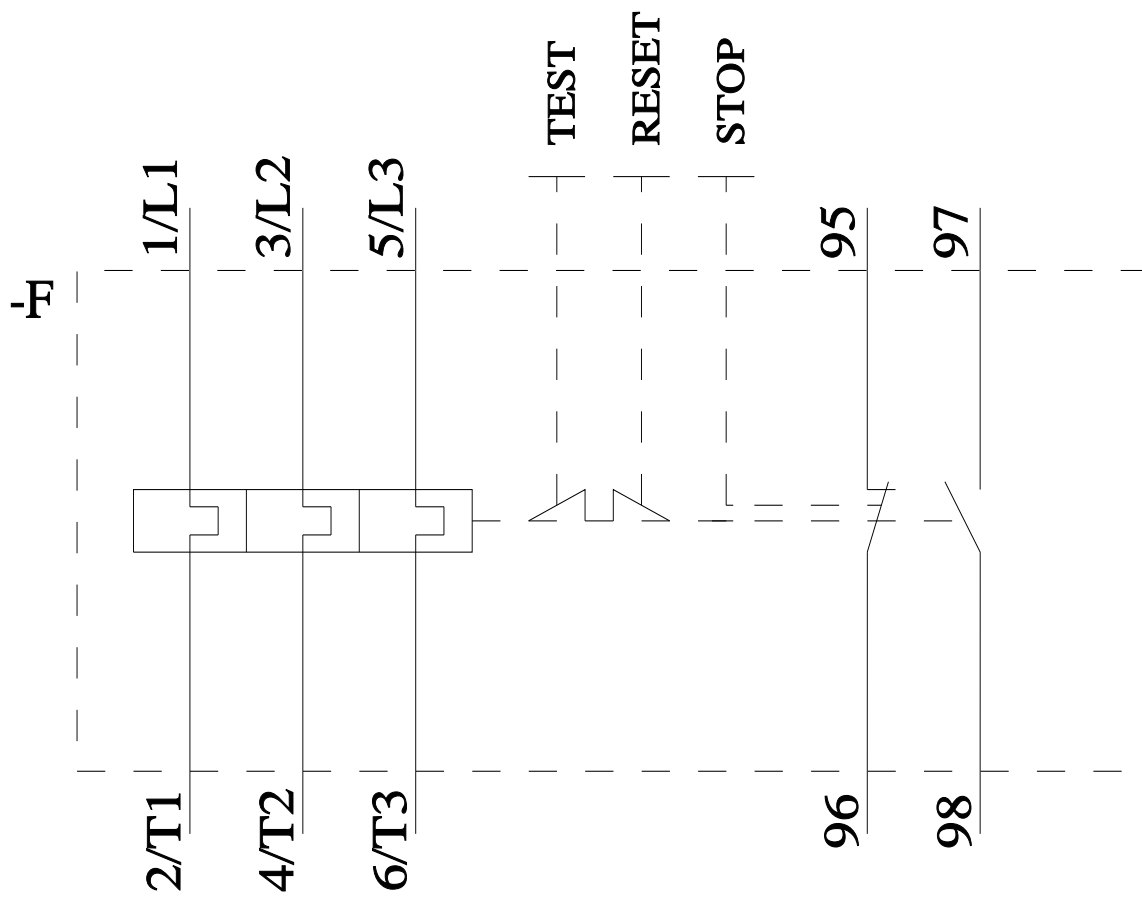

last modified:

4/4/2026 