

# Product datasheet

Specifications



## Contact, TeSys F, 3P(3NO), AC-3 ≤440V 1000A, 220V AC coil

LC1F1000M7

### Main

|                                |  |
|--------------------------------|--|
| Range                          | TeSys  |
| Range of product               | TeSys F  |
| Product or component type      | Contact  |
| Device short name              | LC1F   |
| Contact application            | Motor control<br>Resistive load  |
| Utilisation category           | AC-1<br>AC-3   |
| Poles description              | 3P   |
| [Ue] rated operational voltage | ≤ 440 V AC 50/60 Hz  |
| [Uc] control circuit voltage   | 220 V AC 40...400 Hz   |
| [Ie] rated operational current | 1250 A (at <40 °C) at ≤ 440 V AC AC-1<br>1000 A (at <55 °C) at ≤ 440 V AC AC-3 |

### Complementary

|   |  |
|---|--|
| [Uimp] rated impulse withstand voltage      | 8 kV   |
| [Ith] conventional free air thermal current | 1250 A (at 40 °C)  |
| Rated breaking capacity                     | 8 kA conforming to IEC 60947-4-1   |
| [Icw] rated short-time withstand current    | 10000 A 40 °C - 10 s<br>7500 A 40 °C - 30 s<br>5500 A 40 °C - 1 min<br>4200 A 40 °C - 3 min<br>3000 A 40 °C - 10 min |
| Associated fuse rating                      | 1400 A gG at ≤ 440 V   |
| Average impedance                           | 0.1 mOhm - Ith 1250 A 50 Hz  |
| [Ui] rated insulation voltage               | 1000 V conforming to IEC 60947-4-1<br>1500 V conforming to VDE 0110 group C  |
| Power dissipation per pole                  | 200 W AC-1   |
| Overvoltage category                        | III  |
| power pole contact composition              | 3 NO   |
| Maximum operating rate                      | 600 cyc/h 55 °C  |
| Operating time                              | 40...80 ms closing<br>100...200 ms opening   |

Excluding VAT and subject to change. Please check with your local distributor through "Where to buy"

|                                |  |
|--------------------------------|--|
| <b>Connections - terminals</b> | Control circuit: screw clamp terminals 1 cable(s) 1...4 mm <sup>2</sup> flexible without cable end<br>Control circuit: screw clamp terminals 2 cable(s) 1...4 mm <sup>2</sup> flexible without cable end<br>Control circuit: screw clamp terminals 1 cable(s) 1...4 mm <sup>2</sup> flexible with cable end<br>Control circuit: screw clamp terminals 2 cable(s) 1...2.5 mm <sup>2</sup> flexible with cable end<br>Control circuit: screw clamp terminals 1 cable(s) 1...4 mm <sup>2</sup> solid without cable end<br>Control circuit: screw clamp terminals 2 cable(s) 1...4 mm <sup>2</sup> solid without cable end<br>Power circuit: bar 3 cable(s)<br>Power circuit: bar 4 cable(s) |
| <b>Mounting support</b>        | Plate  |
| <b>motor power range</b>       | 315 kW at 220...230 V 3 phases<br>560 kW at 380...400 V 3 phases<br>630 kW at 415 V 3 phases<br>670 kW at 440 V 3 phases   |
| <b>Motor starter type</b>      | Direct on-line contactor   |
| <b>Contactor coil voltage</b>  | 220 V AC standard  |
| <b>Standards</b>               | EN 60947-1<br>IEC 60947-4-1<br>EN 60947-4-1<br>IEC 60947-1   |
| <b>Product certifications</b>  | CCC<br>CSA<br>CB<br>UKCA   |
| <b>Compatibility code</b>      | LC1F   |
| <b>Control circuit type</b>    | AC at 40...400 Hz  |

## Environment

|  |   |
|--|---|
| <b>IP degree of protection</b>                               | IP20 front face with shrouds conforming to IEC 60529<br>IP20 front face with shrouds conforming to VDE 0106 |
| <b>Protective treatment</b>                                  | TH  |
| <b>Ambient air temperature for operation</b>                 | -5...40 °C  |
| <b>Ambient air temperature for storage</b>                   | -60...80 °C   |
| <b>Permissible ambient air temperature around the device</b> | -40...60 °C   |
| <b>Height</b>  | 332 mm  |
| <b>Width</b>   | 438 mm  |
| <b>Depth</b>   | 238.6 mm  |
| <b>Operating altitude</b>                                    | 3000 m without derating   |
| <b>Net weight</b>  | 31 kg   |

## Packing Units

|                                     |         |
|-------------------------------------|---------|
| <b>Unit Type of Package 1</b>       | PCE     |
| <b>Number of Units in Package 1</b> | 1       |
| <b>Package 1 Height</b>             | 36.1 cm |
| <b>Package 1 Width</b>              | 48.3 cm |
| <b>Package 1 Length</b>             | 60.3 cm |
| <b>Package 1 Weight</b>             | 23.0 kg |

## Contractual warranty

|                             |    |
|-----------------------------|----|
| <b>Warranty (in months)</b> | 18 |
|-----------------------------|----|



## Environmental Data

Schneider Electric aims to achieve Net Zero status by 2050 through supply chain partnerships, lower impact materials, and circularity via our ongoing “Use Better, Use Longer, Use Again” campaign to extend product lifetimes and recyclability.

[Environmental Data explained >](#)

[How we assess product sustainability >](#)



### Environmental footprint

|  |   |
|--|---|
| Total lifecycle Carbon footprint                       | 9 922 kg CO2 eq.                              |
| Environmental Disclosure                               | <a href="#">Product Environmental Profile</a> |
| Carbon footprint of the manufacturing phase [A1 to A3] | 217 kg CO2 eq.                                |
| Carbon footprint of the distribution phase [A4]        | 13 kg CO2 eq.                                 |
| Carbon footprint of the installation phase [A5]        | 0.3 kg CO2 eq.                                |
| Carbon footprint of the use phase [B2, B3, B4, B6]     | 9 635 kg CO2 eq.                              |
| Carbon footprint of the end-of-life phase [C1 to C4]   | 57 kg CO2 eq.                                 |

## Use Better



### Materials and Substances

|  |   |
|--|---|
| Packaging made with recycled cardboard | Yes   |
| Packaging without single use plastic   | No, we have minimized the use of plastic in the packaging in compliance with regulations and considering quality and safety standards |
| <a href="#">EU RoHS Directive</a>      | Compliant with Exemptions   |
| SCIP Number                            | F040462c-f312-4a6d-9d16-164be5751a29  |
| REACH Regulation                       | <a href="#">REACH Declaration</a>   |

## Use Longer



### Lifetime extension

|        |    |
|--------|----|
| Repair | No |
|--------|----|

## Use Again



### Repack and remanufacture

|                                 |   |
|---------------------------------|---|
| Recyclability potential, in %   | 84  |
| End of life manual availability | <a href="#">End of Life Information</a>   |
| Take-back                       | No  |
| WEEE Label                      |  The product must be disposed on European Union markets following specific waste collection and never end up in rubbish bins |

Dimensions Drawings

Dimensions and Drawings

LC1 F1000

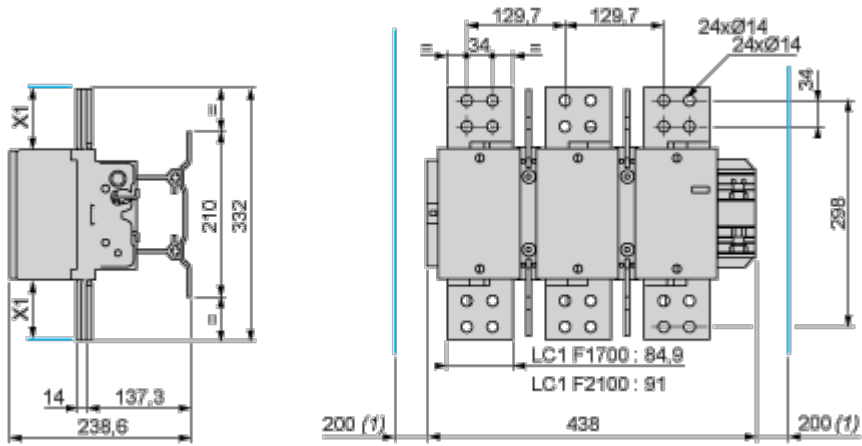

(1) Minimum distance required for coil removal.

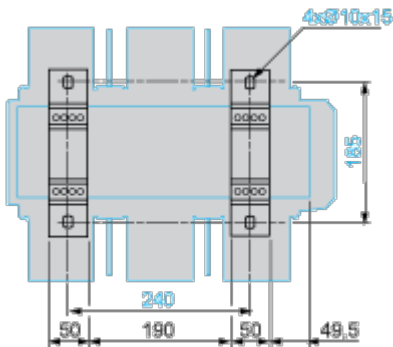

**NOTE:** X1 (mm) = Minimum electrical clearance according to operating voltage and breaking capacity.

| Voltage | 200...500 V | 690...1000 V |
|---------|-------------|--------------|
| X1 (mm) | 90          | 100          |

Technical Illustration

Assembly's dimensions

---

