

Product datasheet

Specifications



Reversing Contactor, TeSys Deca, 3P(3NO), AC-3, <=440V 150A, 48V AC 50/60Hz coil, screw clamp terminals

LC2D150E7

! Discontinued

! Discontinued on: 1 Dec 2024

! To be end-of-service on: 31 Dec 2026

Main

Range	TeSys
Product name	TeSys Deca
Product or component type	Reversing contactor
Device short name	LC2D
Contactor application	Motor control Resistive load
Utilisation category	AC-1 AC-3 AC-3e
Device presentation	Preassembled with reversing power busbar
Poles description	3P
power pole contact composition	3 NO
[Ue] rated operational voltage	Power circuit: <= 1000 V AC 25...400 Hz Power circuit: <= 300 V DC
[Ie] rated operational current	200 A (at <60 °C) at <= 440 V AC AC-1 for power circuit 150 A (at <60 °C) at <= 440 V AC AC-3 for power circuit 150 A (at <60 °C) at <= 440 V AC AC-3e for power circuit
Motor power kW	40 kW at 220...230 V AC 50 Hz 75 kW at 380...400 V AC 50 Hz 80 kW at 415...440 V AC 50 Hz 90 kW at 500 V AC 50 Hz 100 kW at 660...690 V AC 50 Hz 75 kW at 1000 V AC 50 Hz
Motor power hp	40 hp at 200/208 V AC 60 Hz for 3 phases motors 50 hp at 230/240 V AC 60 Hz for 3 phases motors 100 hp at 460/480 V AC 60 Hz for 3 phases motors 125 hp at 575/600 V AC 60 Hz for 3 phases motors
Control circuit type	AC at 50/60 Hz
[Uc] control circuit voltage	48 V AC 50/60 Hz
Auxiliary contact composition	1 NO + 1 NC
[Uimp] rated impulse withstand voltage	8 kV conforming to IEC 60947
Overvoltage category	III
[Ith] conventional free air thermal current	200 A (at 60 °C) for power circuit
Irms rated making capacity	140 A AC for signalling circuit conforming to IEC 60947-5-1 250 A DC for signalling circuit conforming to IEC 60947-5-1 1660 A at 440 V for power circuit conforming to IEC 60947

Excluding VAT, FCA Jabal Ali & amp; are subject to change – check with your local distributor.

Rated breaking capacity	1400 A at 440 V for power circuit conforming to IEC 60947
[Icw] rated short-time withstand current	250 A 40 °C - 10 min for power circuit 580 A 40 °C - 1 min for power circuit 1200 A 40 °C - 10 s for power circuit 1400 A 40 °C - 1 s for power circuit 100 A - 1 s for signalling circuit 120 A - 500 ms for signalling circuit 140 A - 100 ms for signalling circuit
Associated fuse rating	10 A gG for signalling circuit conforming to IEC 60947-5-1 315 A gG at <= 690 V coordination type 1 for power circuit 250 A gG at <= 690 V coordination type 2 for power circuit
Average impedance	0.6 mOhm - lth 200 A 50 Hz for power circuit
[UI] rated insulation voltage	Power circuit: 600 V CSA certified Power circuit: 600 V UL certified Signalling circuit: 690 V conforming to IEC 60947-1 Signalling circuit: 600 V CSA certified Signalling circuit: 600 V UL certified Power circuit: 1000 V conforming to IEC 60947-4-1
Electrical durability	0.85 Mcycles 150 A AC-3 at Ue <= 440 V 1 Mcycles 200 A AC-1 at Ue <= 440 V 0.85 Mcycles 150 A AC-3e at Ue <= 440 V
Power dissipation per pole	24 W AC-1 13.5 W AC-3 13.5 W AC-3e
Front cover	With
Interlocking type	Electrical Mechanical
Mounting support	Rail Plate
Standards	CSA C22.2 No 14 EN 60947-4-1 EN 60947-5-1 IEC 60947-4-1 IEC 60947-5-1 UL 508
Product certifications	BV CCC CSA DNV GL RINA UL EAC UKCA
Connections - terminals	Control circuit: screw clamp terminals 2 cable(s) 1...2.5 mm ² flexible with cable end Control circuit: screw clamp terminals 1 cable(s) 1...2.5 mm ² flexible without cable end Control circuit: screw clamp terminals 2 cable(s) 1...2.5 mm ² flexible without cable end Control circuit: screw clamp terminals 1 cable(s) 1...2.5 mm ² flexible with cable end Control circuit: screw clamp terminals 1 cable(s) 1...2.5 mm ² solid without cable end Control circuit: screw clamp terminals 2 cable(s) 1...2.5 mm ² solid without cable end Power circuit: connector 1 cable(s) 10...120 mm ² flexible without cable end Power circuit: connector 2 cable(s) 10...50 mm ² flexible without cable end Power circuit: connector 1 cable(s) 10...120 mm ² flexible with cable end Power circuit: connector 2 cable(s) 10...50 mm ² flexible with cable end Power circuit: connector 1 cable(s) 10...120 mm ² solid without cable end Power circuit: connector 2 cable(s) 10...50 mm ² solid without cable end
Tightening torque	Control circuit: 1.2 N.m - on screw clamp terminals - with screwdriver flat Ø 6 mm Control circuit: 1.2 N.m - on screw clamp terminals - with screwdriver Philips No 2 Power circuit: 12 N.m - on connector hexagonal screw head 4 mm Control circuit: 1.2 N.m - on screw clamp terminals - with screwdriver pozidriv No 2
Operating time	20...35 ms closing 40...75 ms opening

Safety reliability level	B10d = 1369863 cycles contactor with nominal load conforming to EN/ISO 13849-1 B10d = 20000000 cycles contactor with mechanical load conforming to EN/ISO 13849-1
Mechanical durability	8 Mcycles
Maximum operating rate	1200 cyc/h 60 °C

Complementary

Coil technology	Built-in bidirectional peak limiting diode suppressor
Control circuit voltage limits	0.3...0.5 U _c (55 °C):drop-out AC 50/60 Hz 0.8...1.15 U _c (55 °C):operational AC 50/60 Hz
Inrush power in VA	280...350 VA 60 Hz cos phi 0.9 (at 20 °C) 280...350 VA 50 Hz cos phi 0.9 (at 20 °C)
Hold-in power consumption in VA	2...18 VA (at 20 °C) cos phi 0.9 60 Hz 2...18 VA (at 20 °C) cos phi 0.9 50 Hz
Heat dissipation	3...4.5 W at 50/60 Hz
Auxiliary contacts type	type mechanically linked 1 NO + 1 NC conforming to IEC 60947-5-1 type mirror contact 1 NC conforming to IEC 60947-4-1
Signalling circuit frequency	25...400 Hz
Minimum switching current	5 mA for signalling circuit
Minimum switching voltage	17 V for signalling circuit
Non-overlap time	1.5 ms on de-energisation between NC and NO contact 1.5 ms on energisation between NC and NO contact
Insulation resistance	> 10 MOhm for signalling circuit

Environment

IP degree of protection	IP20 front face conforming to IEC 60529
Climatic withstand	conforming to IACS E10
Protective treatment	TH conforming to IEC 60068-2-30
Pollution degree	3
Ambient air temperature for operation	-40...60 °C 60...70 °C with derating
Ambient air temperature for storage	-60...80 °C
Operating altitude	0...3000 m
Fire resistance	850 °C conforming to IEC 60695-2-1
Flame retardance	V1 conforming to UL 94
Mechanical robustness	Vibrations contactor open: 2 Gn, 5...300 Hz Vibrations contactor closed: 4 Gn, 5...300 Hz Shocks contactor closed: 15 Gn for 11 ms Shocks contactor open: 6 Gn for 11 ms
Height	158 mm
Width	266 mm
Depth	148 mm
Net weight	6.4 kg

Packing Units

Unit Type of Package 1	PCE
Number of Units in Package 1	1

Package 1 Height	23.000 cm
Package 1 Width	31.500 cm
Package 1 Length	37.000 cm
Package 1 Weight	6.500 kg
Unit Type of Package 2	P06
Number of Units in Package 2	8
Package 2 Height	75.000 cm
Package 2 Width	80.000 cm
Package 2 Length	60.000 cm
Package 2 Weight	60.000 kg

Contractual warranty

Warranty (in months)	18
-----------------------------	----



Environmental Data

Schneider Electric aims to achieve Net Zero status by 2050 through supply chain partnerships, lower impact materials, and circularity via our ongoing “Use Better, Use Longer, Use Again” campaign to extend product lifetimes and recyclability.

[Environmental Data explained >](#)

[How we assess product sustainability >](#)



Environmental footprint

Total lifecycle Carbon footprint	242 kg CO2 eq.
Carbon footprint of the manufacturing phase [A1 to A3]	57 kg CO2 eq.
Carbon footprint of the distribution phase [A4]	2 kg CO2 eq.
Carbon footprint of the installation phase [A5]	0.7 kg CO2 eq.
Carbon footprint of the use phase [B2, B3, B4, B6]	171 kg CO2 eq.
Carbon footprint of the end-of-life phase [C1 to C4]	11 kg CO2 eq.
Environmental Disclosure	Product Environmental Profile

Use Better



Materials and Substances

Packaging made with recycled cardboard	Yes
Packaging without single use plastic	Yes
SCIP Number	A530c666-91dd-4119-8d61-f1c22a361ecb
EU RoHS Directive	Compliant By Exemption
REACH Regulation	Reference contains Substances of Very High Concern above the threshold
PVC free	Yes

Use Longer



Lifetime extension

Repair	No
--------	----

Use Again



Repack and remanufacture

Recyclability potential, in %	54
End of life manual availability	End of Life Information
Take-back	Nej
WEEE Label	 The product must be disposed on European Union markets following specific waste collection and never end up in rubbish bins

Dimensions Drawings

Dimensions

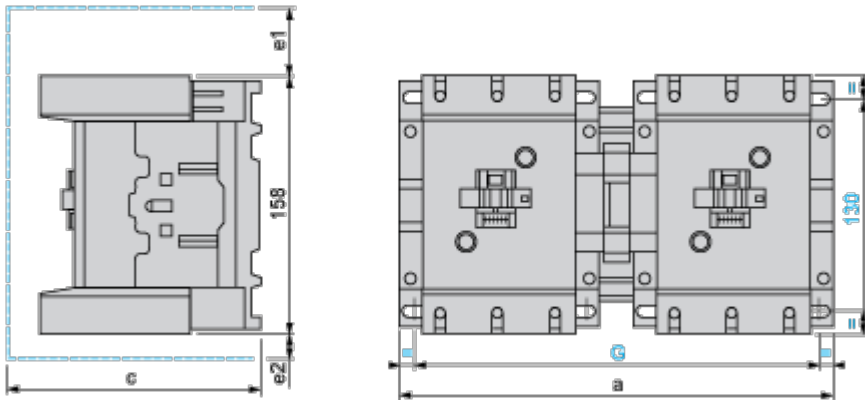

LC2 or 2 x LC1	a	c	e1	e2	G
D115 and D150	266	148	56	18	242/256
c, e1 and e2: including cabling.					

Connections and Schema

Wiring

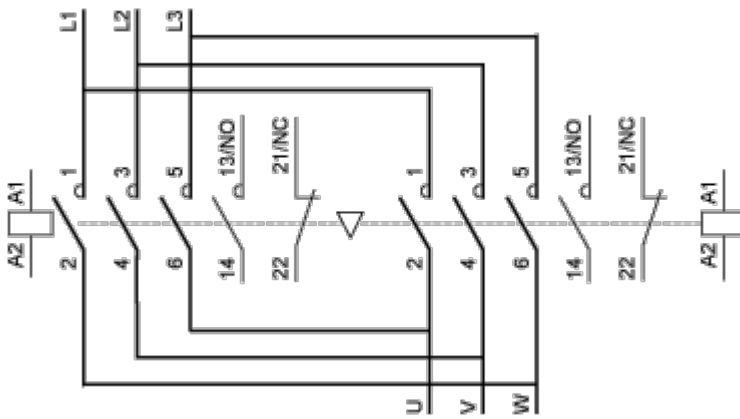

Technical Illustration

Assembly's dimensions

