

# Product datasheet

Specifications



## motion servo drive - Lexium 26 - single and three phase 200...230 V - 50 W

LXM26DUA5M3X

⚠ Discontinued on: 27 Aug 2020

⚠ To be end-of-service on: 30 Jun 2028

⚠ Discontinued

### Main

Range of product	Easy Lexium 26
Device short name	LXM26D
Product or component type	Motion servo drive
Format of the drive	Compact housing
Line current	0.8 A 262.8 % at 220 V, single phase 0.8 A 227 % at 220 V, three phase

### Complementary

Network number of phases	Single phase Three phase
[Us] rated supply voltage	220 V (- 10...15 %) for three phase 220 V (- 20...15 %) for single phase
Supply voltage limits	200...255 V three phase 170...255 V single phase
Supply frequency	50/60 Hz - 5...5 %
Network frequency	47.5...63 Hz
Continuous output current	0.64 A at 16 kHz
Output current 3s peak	2 A at 220 V
Continuous power	50 W at 220 V
Nominal power	0.05 kW at 220 V 16 kHz
Switching frequency	16 kHz
Overvoltage category	III
Maximum leakage current	1.3 mA
Output voltage	<= power supply voltage
Electrical isolation	Between power and control
Type of cable	Twisted shielded pairs cable (single or double) (temperature: 0...55 °C)
Electrical connection	Spring terminal, clamping capacity: 0.82...1 mm <sup>2</sup> , AWG 18 (L1-L2) Spring terminal, clamping capacity: 0.82...1 mm <sup>2</sup> , AWG 18 (R, S, T) Spring terminal, clamping capacity: 0.82...1 mm <sup>2</sup> , AWG 18 (U, V, W, PE) Spring terminal, clamping capacity: 0.82...1 mm <sup>2</sup> , AWG 18 (PA+, PBe)
Tightening torque	PE (ground): 1.4 N.m
Discrete input number	8 programmable (CN1) 1 pulse train input (PTI) (CN1) 2 fast capture (CN1)

<b>Discrete input voltage</b>	24 V DC for logic
<b>Discrete input logic</b>	Positive or negative (CN1)
<b>Discrete output number</b>	5 1
<b>Discrete output type</b>	Logic (CN1) at 12...24 V DC Pulse train output (PTO) (CN1)
<b>Discrete output voltage</b>	12...24 V DC
<b>Discrete output logic</b>	Positive or negative (CN1)
<b>Analogue input number</b>	2
<b>Absolute accuracy error</b>	0.1 %
<b>Analogue input type</b>	V_REF voltage analog input: - 10...10 V, impedance: 10 kOhm, resolution: 12 bits T_REF voltage analog input
<b>Control signal type</b>	Servo motor encoder feedback CN2
<b>Protection type</b>	Against reverse polarity: inputs signal Against short-circuits: outputs signal Overcurrent: motor Overvoltage: motor Undervoltage: motor Overheating: motor Overload: motor Overspeed: motor
<b>Physical interface</b>	RS485 for Modbus Serial line slave
<b>Status LED</b>	1 LED (red) charge
<b>Signalling function</b>	Servo status and fault codes five 7-segment display units
<b>Marking</b>	CULus CSA CE
<b>Type of cooling</b>	Natural convection
<b>Operating position</b>	Vertical
<b>Product compatibility</b>	Servo motor BCH2 (40 mm, 1 motor stacks)
<b>Width</b>	55 mm
<b>Height</b>	150 mm
<b>Depth</b>	146 mm
<b>Net weight</b>	1 kg

## Environment

<b>EMC filter</b>	Without EMC filter
<b>Electromagnetic compatibility</b>	Conducted emission - test level: level 3 category C3 conforming to IEC 61800-3
<b>Standards</b>	IEC 61800-5-1
<b>Product certifications</b>	CSA cULus CE
<b>IP degree of protection</b>	IP20
<b>Vibration resistance</b>	3M4 amplitude = 3 mm (f = 9...200 Hz) conforming to IEC 60721-3-3
<b>Shock resistance</b>	10 gn, type I conforming to IEC 60068-2-27
<b>Relative humidity</b>	5...95 % without condensation
<b>Ambient air temperature for operation</b>	0...55 °C

Ambient air temperature for storage	-25...65 °C
Operating altitude	<= 1000 m without derating > 1000...2000 m 1 % per 100 m

## Packing Units

Unit Type of Package 1	PCE
Number of Units in Package 1	1
Package 1 Height	7.5 cm
Package 1 Width	23 cm
Package 1 Length	23.7 cm
Package 1 Weight	1.26 kg
Unit Type of Package 2	S03
Number of Units in Package 2	5
Package 2 Height	30 cm
Package 2 Width	30 cm
Package 2 Length	40 cm
Package 2 Weight	6.89 kg
Unit Type of Package 3	P06
Number of Units in Package 3	40
Package 3 Height	44.9 cm
Package 3 Width	60 cm
Package 3 Length	80 cm
Package 3 Weight	63.62 kg

## Contractual warranty

Warranty (in months)	18
----------------------	----



## Environmental Data

Schneider Electric aims to achieve Net Zero status by 2050 through supply chain partnerships, lower impact materials, and circularity via our ongoing “Use Better, Use Longer, Use Again” campaign to extend product lifetimes and recyclability.

[Environmental Data explained >](#)

[How we assess product sustainability >](#)



### Environmental footprint

Total lifecycle Carbon footprint	507 kg CO2 eq.
Environmental Disclosure	<a href="#">Product Environmental Profile</a>
Carbon footprint of the manufacturing phase [A1 to A3]	25 kg CO2 eq.
Carbon footprint of the distribution phase [A4]	0.2 kg CO2 eq.
Carbon footprint of the installation phase [A5]	0 kg CO2 eq.
Carbon footprint of the use phase [B2, B3, B4, B6]	480 kg CO2 eq.
Carbon footprint of the end-of-life phase [C1 to C4]	0.7 kg CO2 eq.

## Use Better



### Materials and Packaging

Packaging made with recycled cardboard	No
Packaging without single use plastic	No
PVC free	Yes

## Use Longer



### Lifetime extension

Repair	No
--------	----

## Use Again



### Repack and remanufacture

Recyclability potential, in %	40
End of life manual availability	<a href="#">End of Life Information</a>
Take-back	No

Dimensions Drawings

Dimensions

---

Servo Drive Dimensions

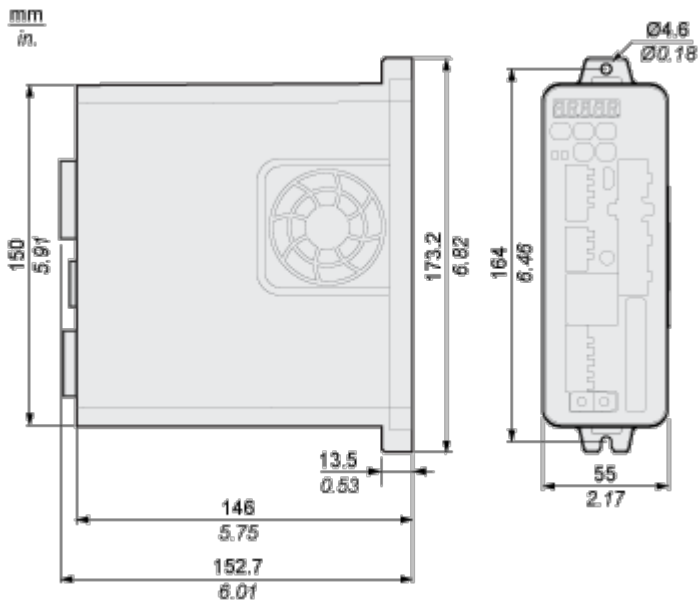

Mounting and Clearance

Mounting and Clearance

Clearance

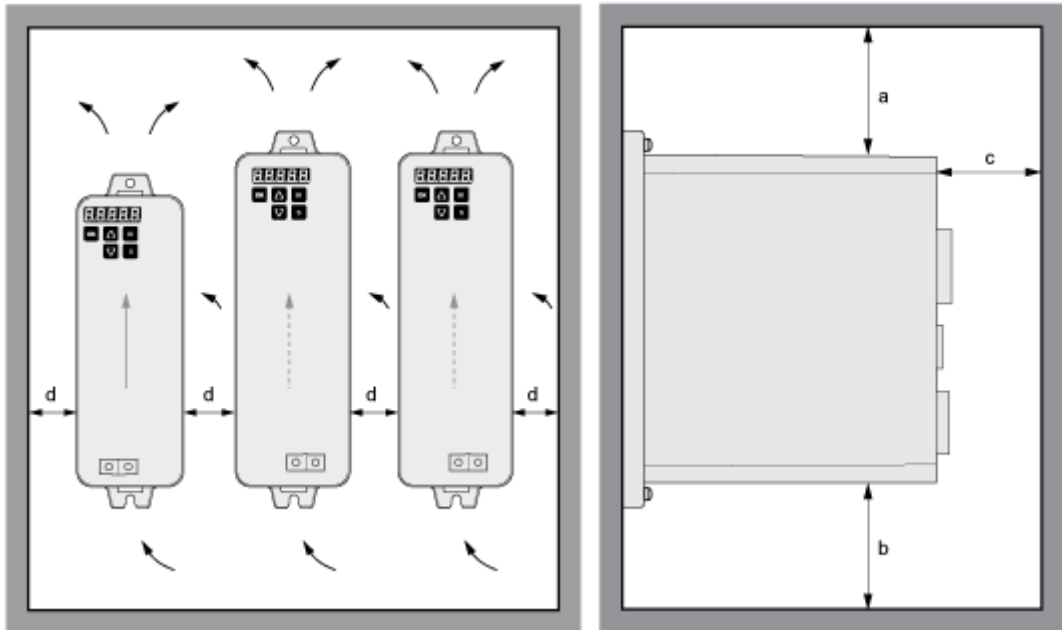

Distance	Unit	Value
Free space <b>a</b> above the device	mm (in)	≥ 50 ≥ 1.97
Free space <b>b</b> below the device	mm (in)	≥ 50 ≥ 1.97
Free space <b>c</b> in front of the device <sup>(1)</sup>	mm (in)	≥ 60 ≥ 2.36
Free space <b>d</b> between devices	mm (in)	≥ 15 ≥ 0.59