

Product datasheet

Specifications



TeSys F contactor - 3P (3 NO) - AC-3 - ≤ 440 V 1000 A - coil 120 V DC

LC1F1000GD

Main

Range	TeSys
Range of product	TeSys F
Product or component type	Contacteur
Device short name	LC1F
Contacteur application	Motor control Resistive load
Utilisation category	AC-3 AC-1
Poles description	3P
[Ue] rated operational voltage	≤ 440 V AC 50/60 Hz
[Uc] control circuit voltage	125 V DC
[Ie] rated operational current	1250 A (at ≤ 40 °C) at ≤ 440 V AC AC-1 1000 A (at ≤ 55 °C) at ≤ 440 V AC AC-3

Complementary

[Uimp] rated impulse withstand voltage	8 kV
[Ith] conventional free air thermal current	1250 A (at 40 °C)
Rated breaking capacity	8 kA conforming to IEC 60947-4-1
[Icw] rated short-time withstand current	10000 A 40 °C - 10 s 7500 A 40 °C - 30 s 5500 A 40 °C - 1 min 4200 A 40 °C - 3 min 3000 A 40 °C - 10 min
Associated fuse rating	1400 A gG at ≤ 440 V
Average impedance	0.1 mOhm - Ith 1250 A 50 Hz
[Ui] rated insulation voltage	1000 V conforming to IEC 60947-4-1 1500 V conforming to VDE 0110 group C
Power dissipation per pole	200 W AC-1
Overvoltage category	III
power pole contact composition	3 NO
Maximum operating rate	600 cyc/h 55 °C
Operating time	40...80 ms closing 100...200 ms opening

Excluding VAT, FCA Jabal Ali & are subject to change – check with your local distributor.

Connections - terminals	Control circuit: screw clamp terminals 1 cable(s) 1...4 mm ² flexible without cable end Control circuit: screw clamp terminals 2 cable(s) 1...4 mm ² flexible without cable end Control circuit: screw clamp terminals 1 cable(s) 1...4 mm ² flexible with cable end Control circuit: screw clamp terminals 2 cable(s) 1...2.5 mm ² flexible with cable end Control circuit: screw clamp terminals 1 cable(s) 1...4 mm ² solid without cable end Control circuit: screw clamp terminals 2 cable(s) 1...4 mm ² solid without cable end Power circuit: bar 3 cable(s) Power circuit: bar 4 cable(s)
Mounting support	Plate
motor power range	315 kW at 220...230 V 3 phases 560 kW at 380...400 V 3 phases 630 kW at 415 V 3 phases 670 kW at 440 V 3 phases
Motor starter type	Direct on-line contactor
Contactor coil voltage	125 V DC standard
Standards	EN 60947-1 IEC 60947-1 IEC 60947-4-1 EN 60947-4-1
Product certifications	CCC CB CSA
Compatibility code	LC1F
Control circuit type	DC standard

Environment

IP degree of protection	IP20 front face with shrouds conforming to IEC 60529 IP20 front face with shrouds conforming to VDE 0106
Protective treatment	TH
Ambient air temperature for operation	-5...40 °C
Ambient air temperature for storage	-60...80 °C
Permissible ambient air temperature around the device	-40...60 °C
Height	332 mm
Width	438 mm
Depth	238.6 mm
Operating altitude	3000 m without derating
Net weight	31 kg

Packing Units

Unit Type of Package 1	PCE
Number of Units in Package 1	1
Package 1 Height	36.1 cm
Package 1 Width	48.3 cm
Package 1 Length	60.3 cm
Package 1 Weight	23 kg

Contractual warranty

Warranty (in months)	18
-----------------------------	----



Environmental Data

Schneider Electric aims to achieve Net Zero status by 2050 through supply chain partnerships, lower impact materials, and circularity via our ongoing “Use Better, Use Longer, Use Again” campaign to extend product lifetimes and recyclability.

[Environmental Data explained >](#)

[How we assess product sustainability >](#)



Environmental footprint

Environmental Disclosure

[Product Environmental Profile](#)

Use Better



Materials and Substances

EU RoHS Directive

[Compliant](#)

Use Longer



Lifetime extension

Repair

No

Use Again



Repack and remanufacture

End of life manual availability

[End of Life Information](#)

WEEE Label



The product must be disposed on European Union markets following specific waste collection and never end up in rubbish bins

Dimensions Drawings

Dimensions and Drawings

LC1 F1000

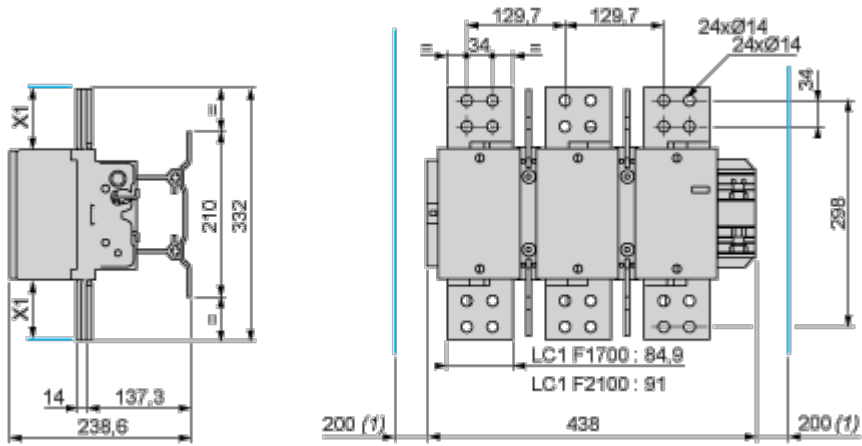

(1) Minimum distance required for coil removal.

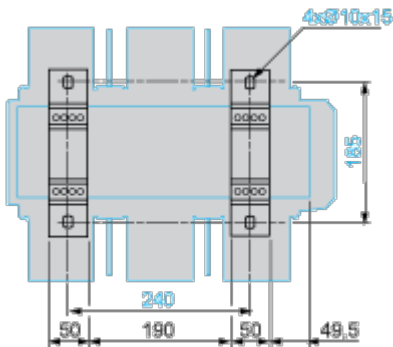

NOTE: X1 (mm) = Minimum electrical clearance according to operating voltage and breaking capacity.

Voltage	200...500 V	690...1000 V
X1 (mm)	90	100