

Detailed technical data

Features

	Visible red light	Infrared light
Sensor principle	Photoelectric proximity sensor	
Detection principle	Background suppression	
Dimensions (W x H x D)	24.6 mm x 82.5 mm x 53.3 mm	
Housing design (light emission)	Rectangular	
Sensing range max. ¹⁾	10 mm ... 1,600 mm	10 mm ... 2,000 mm
Type of light	Visible red light	Infrared light
Light source ²⁾	PinPoint LED	LED
Light spot size (distance)	Ø 7 mm (700 mm)	Ø 14 mm (1,000 mm)
Wave length	635 nm	850 nm
Adjustment	BluePilot: Teach-Turn adjustment with sensing range indicator, IO-Link	
Pin 2 configuration	External Input (test), Teach-in, switching signal	

¹⁾ Object with 90 % reflectance (referred to standard white, DIN 5033).

²⁾ Average service life: 100,000 h at T₀ = +25 °C.

Smart Task

Smart Task name	Base logics
Logic function	Direct AND OR Window Hysteresis
Timer function	Deactivated On delay Off delay ON and OFF delay Impulse (one shot)
Inverter	Yes
Switching frequency	SIO Direct: 1000 Hz ¹⁾ SIO Logic: 800 Hz ²⁾ IOL: 650 Hz ³⁾
Response time	SIO Direct: 500 µs ¹⁾ SIO Logic: 600 µs ²⁾ IOL: 750 µs ³⁾
Repeat accuracy	SIO Direct: 150 µs ¹⁾ SIO Logic: 300 µs ²⁾ IOL: 400 µs ³⁾
Switching signal Q_{L1}	Switching output
Switching signal Q_{L2}	Switching output

¹⁾ SIO Direct: sensor operation in standard I/O mode without IO-Link communication and without using internal sensor logic or time parameters (set to "direct"/"deactivated").

²⁾ SIO Logic: Sensor operation in standard I/O mode without IO-Link communication. Sensor-internal logic or timing parameters plus Automation Functions used.

³⁾ IOL: Sensor operation with full IO-Link communication and usage of logic, timing and Automation Function parameters.

Mechanics/electronics

Supply voltage ¹⁾	10 V DC ... 30 V DC
Ripple	≤ 5 V _{pp}
Power consumption	≤ 30 mA ²⁾ < 50 mA ³⁾
Output type	PUSH/PULL, PNP, NPN
Output function	Complementary, Pin 2: NPN normally open (light switching), PNP normally closed (dark switching), Pin 4: NPN normally closed (dark switching), PNP normally open (light switching), IO-Link
Switching mode	Light/dark switching
Signal voltage PNP HIGH/LOW	Approx. V _s - 2.5 V / 0 V
Signal voltage NPN HIGH/LOW	Approx. V _S / < 2.5 V
Output current I_{max}	≤ 100 mA
Response time ⁴⁾	≤ 500 μs
Switching frequency ⁵⁾	1,000 Hz
Connection type	Cable, M12, 2 m ⁶⁾ Male connector, M12 Cable with male connector, M12, 270 mm ⁶⁾ (depending on type)
Circuit protection	A ⁷⁾ , B ⁸⁾ , C ⁹⁾ , D ¹⁰⁾
Protection class	III
Weight	
Cable	130 g
Male connector M12, 4-pin	80 g
Cable with M12 male connector, 4-pin	100 g
Housing material	Plastic, VISTAL®
Optics material	Plastic, PMMA
Enclosure rating	IP66, IP67
Ambient operating temperature	-40 °C ... +60 °C
Ambient storage temperature	-40 °C ... +75 °C

¹⁾ Limit values.

²⁾ 16 V DC ... 30 V DC, without load.

³⁾ 10 V DC ... 16 V DC, without load.

⁴⁾ Signal transit time with resistive load in switching mode. Different values possible in COM2 mode.

⁵⁾ With light/dark ratio 1:1 in switching mode. Different values possible in IO-Link mode.

⁶⁾ Do not bend below 0 °C.

⁷⁾ A = V_s connections reverse-polarity protected.

⁸⁾ B = inputs and output reverse-polarity protected.

⁹⁾ C = interference suppression.

¹⁰⁾ D = outputs overcurrent and short-circuit protected.

Communication interface

	Visible red light	Infrared light
Communication interface	IO-Link V1.1	
Mode	COM2 (38,4 kBaud)	
Cycle time	2.3 ms	
Process data length	16 Bit	
Process data structure	Bit 0 = switching signal Q _{L1} Bit 1 = switching signal Q _{L2} Bit 2 ... 15 = empty	
VendorID	26	

Ordering information

Visible red light

- **Detection principle:** Background suppression
- **Switching mode:** Light/dark switching
- **Adjustment:** BluePilot: Teach-Turn adjustment with sensing range indicator, IO-Link

Sensing range max. ¹⁾	Light spot size (distance)	Output type	Connection	DeviceID	Connection diagram	Type	Part no.
10 mm ... 1,600 mm	Ø 7 mm (700 mm)	PUSH/PULL, PNP, NPN	Cable, 2 m, PVC	8388984 dez / 0x800178	cd-389	WTB26P- 1H161120A00	1218824
			Male connector M12, 4-pin	8388984 dez / 0x800178	cd-390	WTB26P- 24161120A00	1218666
			Cable with M12 male connector, 4-pin, 270 mm, PVC	8388984 dez / 0x800178	cd-390	WTB26P- 34161120A00	1218806

¹⁾ Object with 90 % reflectance (referred to standard white, DIN 5033).

Infrared light

- **Detection principle:** Background suppression
- **Switching mode:** Light/dark switching
- **Adjustment:** BluePilot: Teach-Turn adjustment with sensing range indicator, IO-Link

Sensing range max. ¹⁾	Light spot size (distance)	Output type	Connection	DeviceID	Connection diagram	Type	Part no.
10 mm ... 2,000 mm	Ø 14 mm (1,000 mm)	PUSH/PULL, PNP, NPN	Cable, 2 m, PVC	8388996 dez / 0x800184	cd-389	WTB26I- 1H161120A00	1218825
			Male connector M12, 4-pin	8388996 dez / 0x800184	cd-390	WTB26I- 24161120A00	1218667
			Cable with M12 male connector, 4-pin, 270 mm, PVC	8388996 dez / 0x800184	cd-390	WTB26I- 34161120A00	1218827

¹⁾ Object with 90 % reflectance (referred to standard white, DIN 5033).

Dimensional drawings (Dimensions in mm (inch))

WTB26, cable

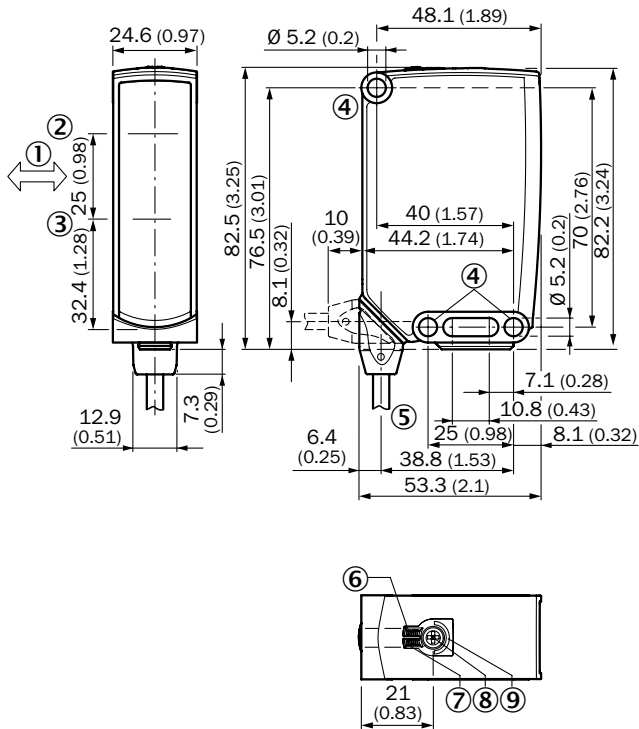

WTB26, connector

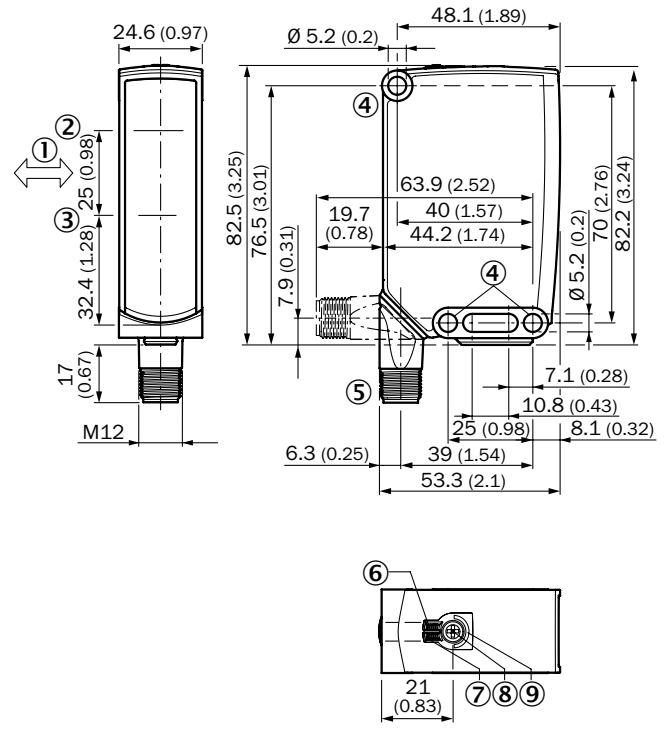

- ① Standard direction of the material being detected
- ② Center of optical axis, sender
- ③ Center of optical axis, receiver
- ④ Mounting hole, Ø 5.2 mm
- ⑤ Connection
- ⑥ LED indicator green: power
- ⑦ LED indicator yellow: Status of received light beam
- ⑧ Teach-Turn adjustment of sensing range
- ⑨ BluePilot blue: sensing range indicator

- ① Standard direction of the material being detected
- ② Center of optical axis, sender
- ③ Center of optical axis, receiver
- ④ Mounting hole, Ø 5.2 mm
- ⑤ Connection
- ⑥ LED indicator green: power
- ⑦ LED indicator yellow: Status of received light beam
- ⑧ Teach-Turn adjustment of sensing range
- ⑨ BluePilot blue: sensing range indicator

Connection diagram

Cd-389

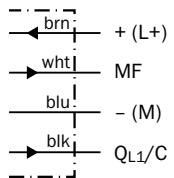

Default: MF = \bar{Q}
 QL1/C = Q

Cd-390

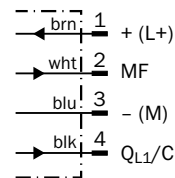

Default: MF = \bar{Q}
 QL1/C = Q

Characteristic curves

WTB26P-xxxxx1xx

Minimum distance in mm (y) between the set sensing range and background (white, 90%)

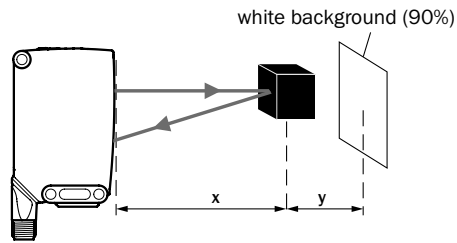
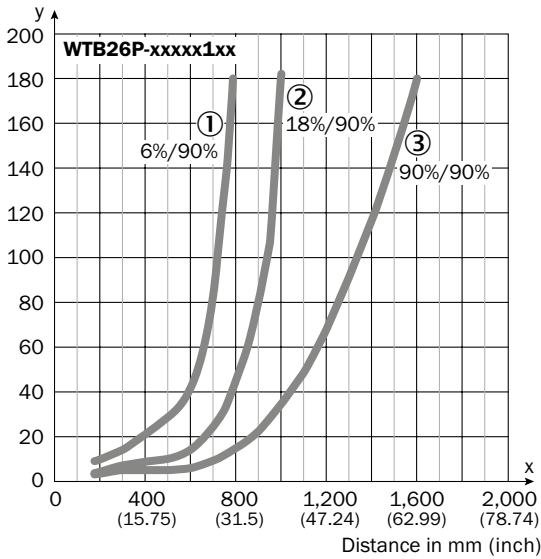

Example:
Sensing range on black, 6%,
x = 600 mm, y = 40 mm

- ① Sensing range on black, 6% remission
- ② Sensing range on gray, 18% remission
- ③ Sensing range on white, 90% remission

WTB26I-xxxxx1xx

Minimum distance in mm (y) between the set sensing range and background (white, 90%)

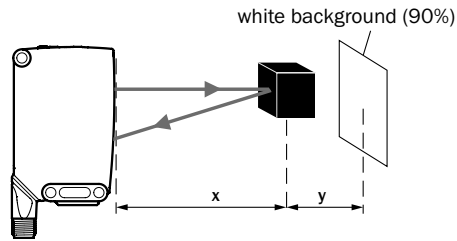
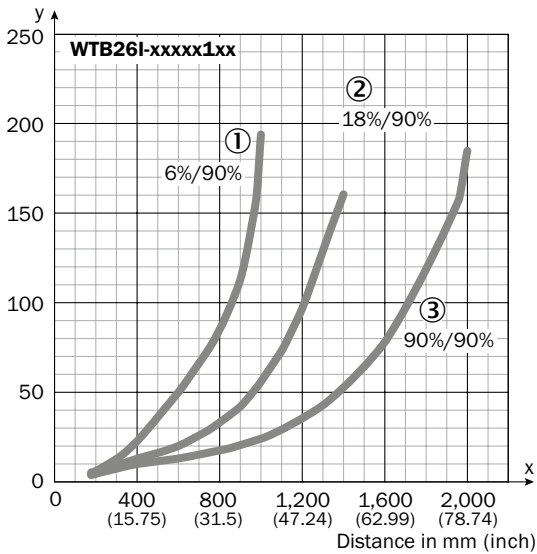

Example:
Sensing range on black, 6%,
x = 800 mm, y = 85 mm

- ① Sensing range on black, 6% remission
- ② Sensing range on gray, 18% remission
- ③ Sensing range on white, 90% remission

Bar diagrams

WTB26P-xxxxx1xx

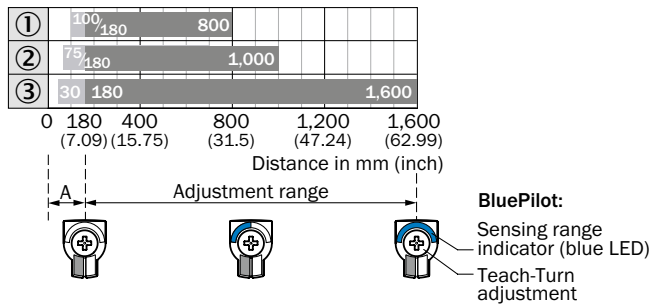

A = Detection distance (depending on object remission)

- ① Sensing range on black, 6% remission
- ② Sensing range on gray, 18% remission
- ③ Sensing range on white, 90% remission

WTB26I-xxxxx1xx

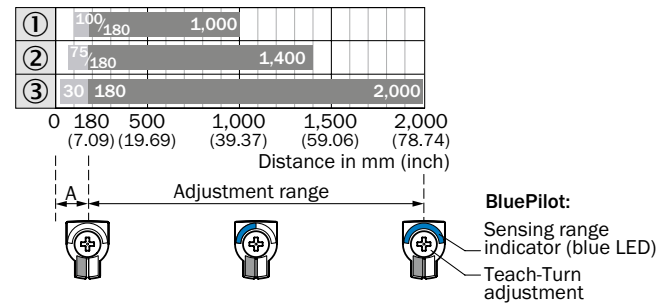

A = Detection distance (depending on object remission)

- ① Sensing range on black, 6% remission
- ② Sensing range on gray, 18% remission
- ③ Sensing range on white, 90% remission

Light spot diameter

WTB26P-xxxxx1xx

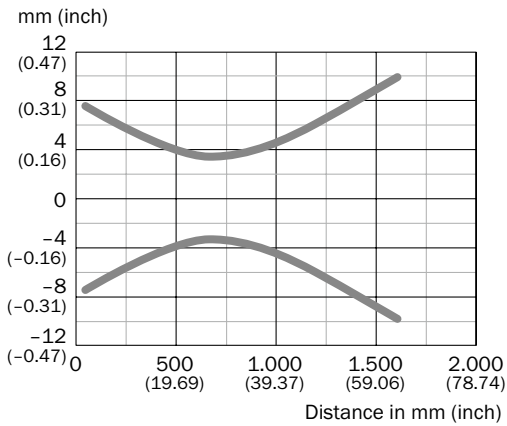

WTB26I-xxxxx1xx

