

Product datasheet

Specifications



EtherCAT motion controller, Modicon M310, 16 Axis, 8DI, 8DO, Transistor, NPN, EtherCAT, Ethernet, RS485

TM310MM35ECT16U

Main

Range of product	Modicon M310
Product or component type	Motion controller
[Us] rated supply voltage	24 V DC -15...20 %
Discrete I/O number	16
Upstream connectivity	Connected machine to plant

Complementary

PLC Power Consumption	26 W (100% load) with 25 °C 2.99 W (load free) with 25 °C
Inrush current	50 A
Overvoltage protection	With
Discrete input number	8, discrete input 8 high speed input conforming to IEC 61131-2 type 3
Discrete input voltage	24 V
Discrete input voltage type	DC
Discrete input logic	Sink or source for 2/3-wire proximity sensors PNP/NPN input conforming to IEC 61131-2 type 3
Voltage state 1 guaranteed	≥ 11 V for DC
Voltage state 0 guaranteed	0...5 V for DC
Discrete input current	3 mA for high speed input
Response time	≤ 1 μ s turn-on, I0...I7 terminal(s) for fast input ≤ 1 μ s turn-off, I0...I7 terminal(s) for fast input ≤ 1 μ s turn-on, Q0...Q7 terminal(s) for fast output ≤ 1 μ s turn-off, Q0...Q7 terminal(s) for fast output
Configurable filtering time	0 ms for fast input 0.001 ms for fast input 0.002 ms for fast input 0.005 ms for fast input 0.01 ms for fast input 0.05 ms for fast input 0.1 ms for fast input 0.5 ms for fast input 1 ms for fast input 4 ms for fast input 12 ms for fast input
Discrete output number	8 transistor 8 fan output
Discrete output voltage	24 V DC
Discrete output current	0.5 A for fan output (Q0...Q7)
Discrete output type	Transistor
Discrete output logic	Source

Output voltage limits	20.4...28.8 V DC
Maximum current per output common	2 A with Q0...Q7 for fast output
Maximum output frequency	200 kHz
Maximum leakage current	0.3 mA for output
Maximum voltage drop	<1 V
Maximum tungsten load	<1 W
Protection type	Short-circuit and overload protection with automatic reset Reverse polarity protection Short-circuit protection 1 external fuse
Reset time	1000 ms automatic reset fast output
Maximum number of I/O expansion module	7TM3 IO module (local I/O-Architecture) 14TM3 IO module (remote I/O-Architecture) 14TM3 IO module (distributed I/O-Architecture)
Execution time for 1 KInstruction	0.6 ms
Memory capacity	16 MB for user application and data RAM 512 KB flash
Data storage equipment	<= 32 GB SDHC card (optional)
Backup time	2 years at 25 °C (by interruption of power supply)
Battery type	CR2032 1 backup battery optional, battery life: 5 year(s)
Application structure	8 event tasks 8 external event tasks
Realtime clock	Built-in
Cycle time	1 ms 8 EtherCAT
Positioning functions	Libraries axes synchronous function Homing function Jog function CSV function CSP function
Integrated connection type	EtherCAT 1 with RJ45 connector and 100-BASE-TX category 5 or industrial Ethernet interface Ethernet 1 with RJ45 connector and 10/100BASE-T interface Ethernet 2 with RJ45 connector and 10/100BASE-T interface Serial link with removable spring connector connector and RS-485 (isolation) interface USB type C with USB 2.0 connector TM3 IO bus
Communication port protocol	EtherCAT master 100 Mbps EtherNet/IP adapter 10/100 Mbps EtherNet/IP scanner 10/100 Mbps Modbus TCP client/server 10/100 Mbps OPC UA server 10/100 Mbps TCP/UDP master/slave 10/100 Mbps Modbus RTU master/slave 1.2...115.2 kbauds Modbus ASCII master 1.2...115.2 kbauds
Maximum number of connected devices	EtherCAT: 127 line (shielded) Modbus TCP server: 16 (shielded) Modbus TCP client: 64 (shielded) EtherNet/IP scanner: 16 (shielded) EtherNet/IP (adapter): 16 (shielded) OPC UA server: 4 (shielded) Modbus RTU master on RS485: 31 line (shielded, twisted pair cable)

Local signalling	1 LED (green) for PWR (Power Status) 1 LED (green) for RUN 1 LED (red) for ERR (Error) 1 LED (red) for I/O 1 LED (green/yellow) for SD card access (SD) 1 LED (red) for BAT 1 LED (green) for SL1 1 LED (green/red) for ECT 1 LED (green) for ETH1 state 1 LED (green) for ETH2 state
Electrical connection	4-pin removable spring terminal block, 1 terminal(s)for serial communication 3-pin removable screw terminal block, 1 terminal(s)for connecting the 24 V DC power supply
Maximum cable distance between devices	Unshielded cable: <50 m for fast input (normal mode) Shielded cable: <10 m for fast input (HSC mode) Unshielded cable: <50 m for fast output (normal mode) Shielded cable: <3 m for fast output (PLS/PWM/PTO mode) Shielded cable: <100 m for Ethernet network Twisted shielded cable: <1000 m for RS485 link Shielded cable: <3 m for USB 2.0
Insulation	Between supply and ground at 560 V AC Between input and output at 560 V AC Between input and communication at 560 V AC Between input and ground at 560 V AC Between output and ground at 560 V AC
Surge withstand	1 kV power lines (DC) common mode conforming to EN/IEC 61000-4-5 0.5 kV power lines (DC) differential mode conforming to EN/IEC 61000-4-5 1 kV shielded cable common mode conforming to EN/IEC 61000-4-5 1 kV digital I/O common mode conforming to EN/IEC 61000-4-5
Counting input number	8 fast input (HSC mode) at 200 kHz
Control signal type	A/B at 200 kHz for fast input (HSC mode) Pulse/direction at 200 kHz for fast input (HSC mode) Single phase at 200 kHz for fast input (HSC mode)
Mounting support	Top hat type TH35-15 DIN rail conforming to IEC 60715
Height	100 mm
Depth	85 mm
Width	60 mm
Net weight	0.247 kg

Environment

Standards	IEC 61131-2 IEC/EN 61010-2-201 RoHS REACH
Product certifications	CE
Resistance to electrostatic discharge	6 kV on contact conforming to IEC 61000-4-2 8 kV on air conforming to IEC 61000-4-2
Resistance to electromagnetic fields	12 V/m 80 MHz...1 GHz conforming to IEC 61000-4-3 3 V/m 1.4 GHz...2 GHz conforming to IEC 61000-4-3 1 V/m 2 GHz...3 GHz conforming to IEC 61000-4-3
Resistance to fast transients	2 kV (power lines (DC)) conforming to EN/IEC 61000-4-4 1 kV (digital I/O) conforming to EN/IEC 61000-4-4
Resistance to conducted disturbances	10 V 0.15...80 MHz conforming to EN/IEC 61000-4-6
Immunity to microbreaks	10 ms
IP degree of protection	IP20
Pollution degree	2
Operating altitude	0...2000 m

Vibration resistance	3.5 mm at 5...8.4 Hz on DIN rail 1 gn at 8.4...150 Hz on DIN rail
Shock resistance	15 g for 11 ms

Packing Units

Unit Type of Package 1	PCE
Number of Units in Package 1	1
Package 1 Height	7.7 cm
Package 1 Width	10.0 cm
Package 1 Length	13.1 cm
Package 1 Weight	286.28 g
Unit Type of Package 2	S03
Number of Units in Package 2	18
Package 2 Height	30 cm
Package 2 Width	30 cm
Package 2 Length	40 cm
Package 2 Weight	5.2 kg



Environmental Data

Schneider Electric aims to achieve Net Zero status by 2050 through supply chain partnerships, lower impact materials, and circularity via our ongoing “Use Better, Use Longer, Use Again” campaign to extend product lifetimes and recyclability.

[Environmental Data explained >](#)

[How we assess product sustainability >](#)



Environmental footprint

Total lifecycle Carbon footprint	1 989 kg CO2 eq.
Environmental Disclosure	Product Environmental Profile
Carbon footprint of the manufacturing phase [A1 to A3]	107 kg CO2 eq.
Carbon footprint of the distribution phase [A4]	0.2 kg CO2 eq.
Carbon footprint of the installation phase [A5]	0 kg CO2 eq.
Carbon footprint of the use phase [B2, B3, B4, B6]	1 882 kg CO2 eq.
Carbon footprint of the end-of-life phase [C1 to C4]	0.7 kg CO2 eq.

Use Longer



Lifetime extension

Repair	No
--------	----

Use Again



Repack and remanufacture

Recyclability potential, in %	0
End of life manual availability	End of Life Information
Take-back	No

Dimensions Drawings

Dimensions

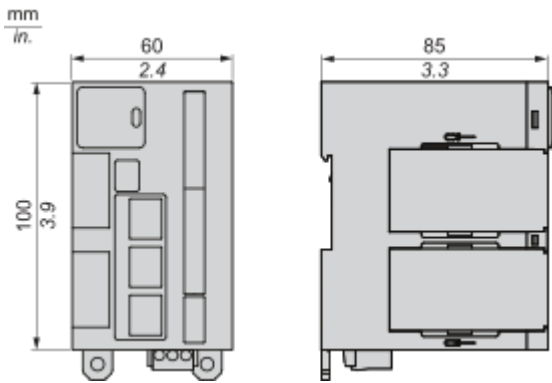

Mounting and Clearance

Mounting Positions

Correct Mounting Position

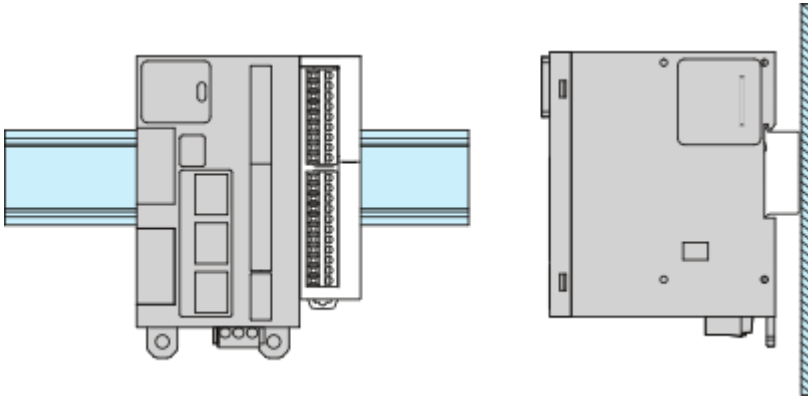

Acceptable Mounting Position

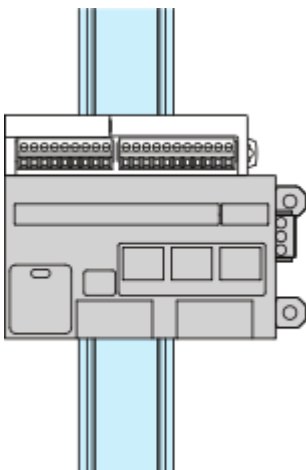

Incorrect Mounting Positions

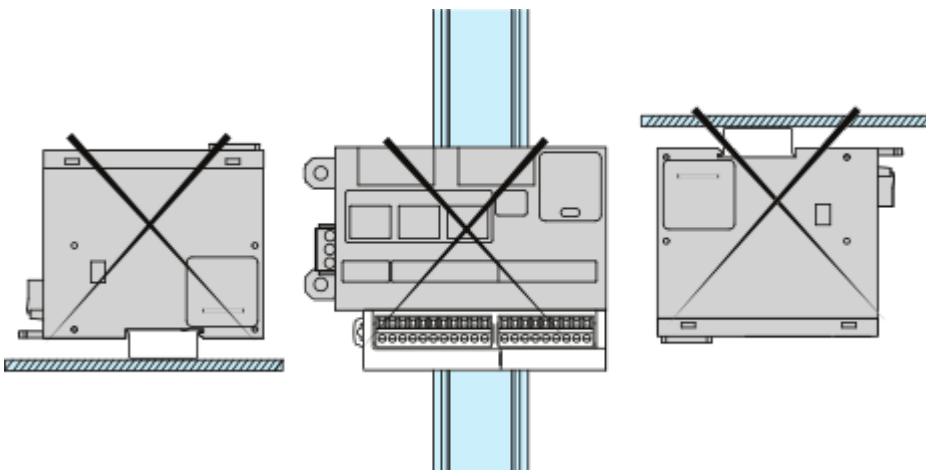

Connections and Schema

Wiring Diagrams

Digital Inputs

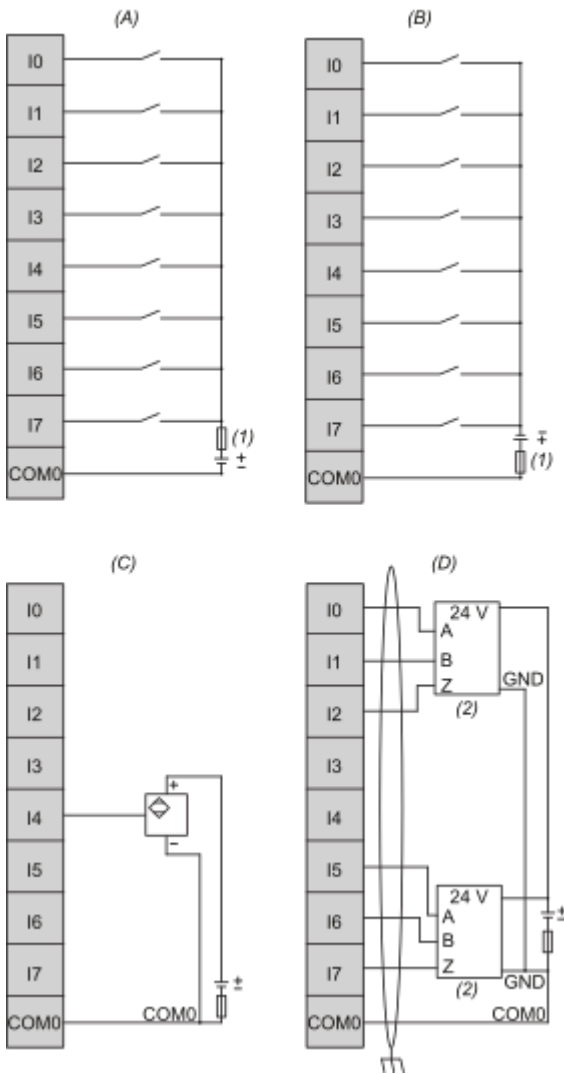

- (1) : Type T fuse 0.1 A
- (2) : Encoder
- (A) : 2-wire Sink input
- (B) : 2-wire Source input
- (C) : 3-wire input
- (D) : 24 Vdc incremental encoder with push-pull at outputs

Digital Outputs Source Wiring

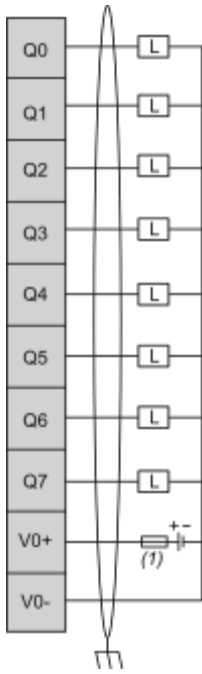

(1) : Type T fuse 3.2 A

Digital Outputs Sink Wiring

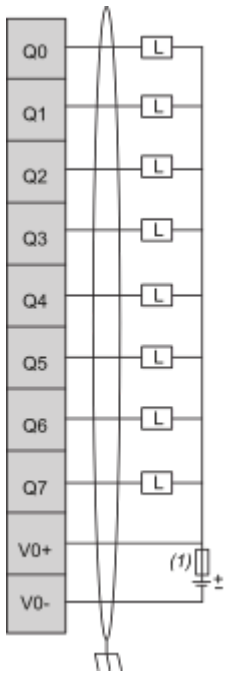

(1) : Type T fuse 3.2 A

Image of product / Alternate images

Alternative





