

Article No. : 1FL2204-2AF10-1MCO



Client order no. :
Order no. :
Offer no. :
Remarks :

Item no. :
Consignment no. :
Project :

Basic motor data

| | |
|-------------------------|---|
| Motor type | Permanent-magnet synchronous motor, Natural cooling |
| Motor type | Medium Inertia |
| Static torque | 2.40 Nm |
| Static current | 2.25 A |
| Maximum torque | 7.50 Nm |
| Maximum current | 7.10 A |
| Maximum speed | 6,500 rpm |
| Rotor moment of inertia | 1.2300 kgcm ² |
| Weight | 3.40 kg |

Rated data

SINAMICS S200, 3 AC 380 ... 480 V

| | |
|---------------|-----------|
| Rated speed | 3,000 rpm |
| Rated torque | 2.40 Nm |
| Rated current | 2.25 A |
| Rated power | 0.75 kW |

Encoder system

| | |
|----------------|---|
| Encoder system | Absolute encoder 21-bit singleturn + 12-bit multiturn |
|----------------|---|

Motor connection

| | |
|-----------------|------------------------|
| Connection type | Metal hybrid connector |
|-----------------|------------------------|

Mechanical data

| | |
|-------------------------------|--|
| Design acc. to Code I | IM B5 (IM V1, IM V3) |
| Vibration severity grade | Grade A |
| Shaft height | 40 |
| Flange size (AB) | 81 mm |
| Centering ring (N) | 70 mm |
| Hole circle (M) | 90 mm |
| Screw-on hole (S) | 6.6 mm |
| Overall length (LB) | 168.6 mm |
| Diameter of shaft (D) | 19 mm |
| Length of shaft (E) | 40 mm |
| Length of flange diagonal (P) | 104.9 mm |
| Shaft end | Shaft with parallel key (half-key balancing) |
| Color of the housing | Anthracite RAL 7016 |

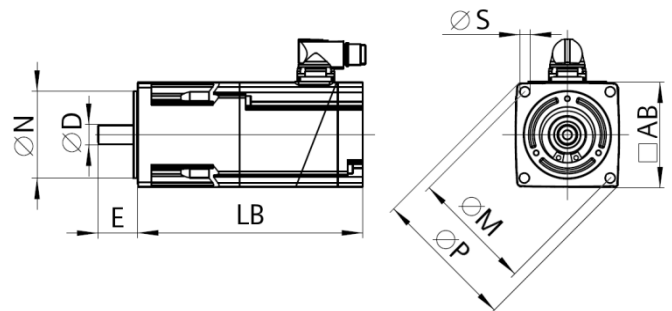

Holding brake

| | |
|--------------------------|--------------|
| Rated voltage | 24 V DC 10 % |
| Rated current | 0.60 A |
| Holding torque M_{4Br} | 3.30 Nm |
| Opening time | 100 ms |
| Closing time | 15 ms |