

Product data sheet

Specifications



3-phase stepper motor - 2.26 Nm - shaft $\tilde{\sim}$ 12 mm - L = 68 mm - with brake - conn

BRS397H361FCA

⚠ Discontinued on: Aug 7, 2023

⚠ Discontinued

Main

Range compatibility	Lexium SD3
Product or component type	Motion control motor
Device short name	BRS3
Maximum mechanical speed	3000 rpm
Motor type	3-phase stepper motor
Number of motor poles	6
Supply voltage limits	34 V AC 48 V DC
Mounting support	Flange
Motor flange size	3.3 in (85 mm)
Length	6.2 in (157 mm)
Centring collar diameter	2.4 in (60 mm)

Complementary

Centring collar depth	0.08 in (2 mm)
Number of mounting holes	4
Mounting holes diameter	0.3 in (6.5 mm)
Circle diameter of the mounting holes	3.90 in (98.99 mm)
Electrical connection	Connector
Feedback type	Single turn encoder
Speed feedback resolution	10000 points/turn
Holding brake	With
Shaft end	Smooth shaft
Second shaft	Without second shaft end
Shaft diameter	0.5 in (12 mm)
Shaft length	1.2 in (30 mm)
Nominal torque	17.7 lbf.in (2 N.m)
Holding torque	20.003 lbf.in (2.26 N.m)
Rotor inertia	1.1 kg.cm ²
Resolution	1.8 °, 0.9 °, 0.72 °, 0.36 °, 0.18 °, 0.09 °, 0.072 °, 0.036 ° step angle 200, 400, 500, 1000, 2000, 4000, 5000, 10000 steps number of full steps per revolution

Accuracy error	+/- 6 arc min
Maximum starting frequency	5 kHz
[In] rated current	5.8 A
Resistance	0.35 Ohm winding)
Time constant	7 ms
Maximum radial force Fr	100 N first shaft end) 50 N second shaft end)
Maximum axial force Fa	175 N tensile force) 30 N force pressure)
Service life in hours	20000 h bearing)
Angular acceleration	200000 rad/s ²
Net weight	4.6 lb(US) (2.1 kg)

Environment

Standards	IEC 50347 IEC 60072-1
Type of cooling	Natural convection
Ambient air temperature for operation	-13...104 °F (-25...40 °C)
Ambient air temperature for storage	-13...158 °F (-25...70 °C)
Operating altitude	<= 1000 m without power derating
Relative humidity	15...85 % without condensation
Vibration resistance	20 m/s ² maximum A IEC 60034-14
IP degree of protection	IP56 total except shaft bushing: conforming to IEC 60034-5 IP41 shaft bushing without shaft seal ring: conforming to IEC 60034-5
Temperature class	F winding IEC 60034-1

Packing Units

Unit Type of Package 1	PCE
Number of Units in Package 1	1
Package 1 Height	4.9 in (12.5 cm)
Package 1 Width	7.09 in (18.0 cm)
Package 1 Length	14.4 in (36.5 cm)
Package 1 Weight	9.9 lb(US) (4.5 kg)

Contractual warranty

Warranty (in months)	18
----------------------	----



Environmental Data

Schneider Electric aims to achieve Net Zero status by 2050 through supply chain partnerships, lower impact materials, and circularity via our ongoing “Use Better, Use Longer, Use Again” campaign to extend product lifetimes and recyclability.

[Environmental Data explained >](#)

[How we assess product sustainability >](#)

Use Better



Materials and Substances

EU RoHS Directive

[Compliant By Exemption](#)

PVC free

Yes

Use Longer



Lifetime extension

Repair

No

Use Again



Repack and remanufacture

Circularity Profile

No need of specific recycling operations

WEEE Label



The product must be disposed on European Union markets following specific waste collection and never end up in rubbish bins

Dimensions Drawings

Dimensions

3-Phase Stepper Motor in Connector Version

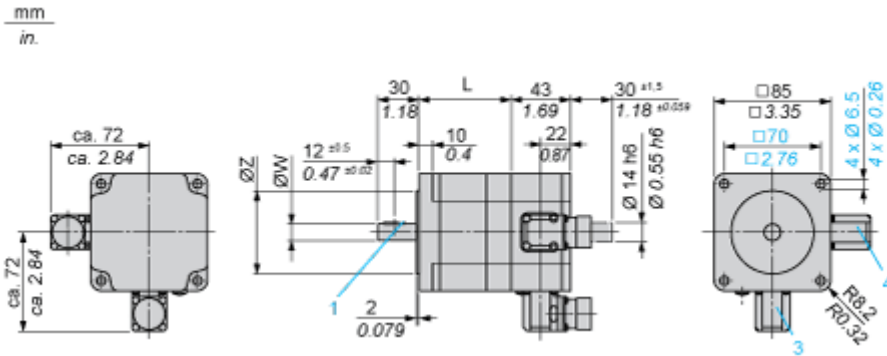

- 3: Motor connection 6 poles
- 4: Motor connection (optional) 12 poles

Holding Brake

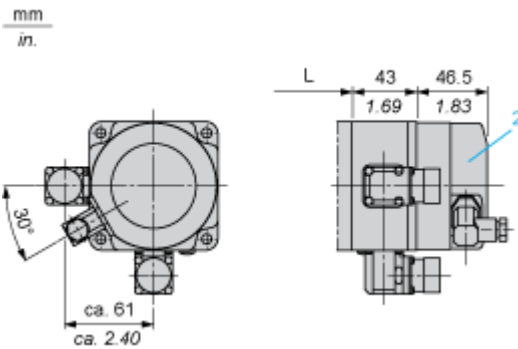

- 2: Holding brake (optional)

Dimensions in mm

L	Shaft diameter ØW	Centring collar ØZ	Woodruff key DIN 6888 (1)
67.5 (+0.6) (-0.8)	12 h6	60 h8	4 x 6.5

Dimensions in in.

L	Shaft diameter ØW	Centring collar ØZ	Woodruff key DIN 6888 (1)
2.66 (+0.023) (-0.031)	0.47 h6	2.36 h8	0.16 x 0.25

Connections and Schema

Wiring Diagram of Holding Brake

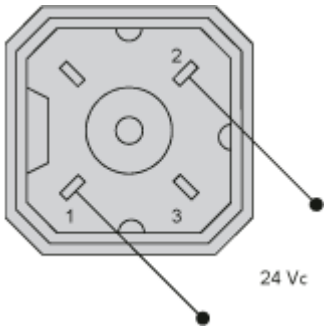

The connector is part of the scope of delivery. Connector designation: Hirschmann type G4 A 5M

Wiring Diagram of Encoder Plug on BRS3••

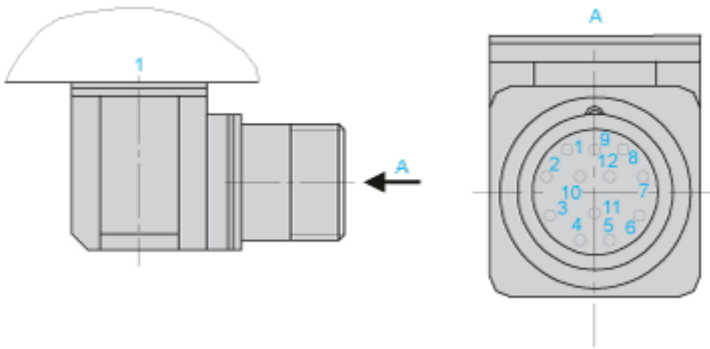

1 : Motor housing

Pin	Designation
1	A
2	A negated
3	B
4	B negated
5	C, I
6	C negated, I negated
7	5 V _{GND}
8	+ 5
9	-SENSE
10	+SENSE
11	Temperature sensor
12	Not connected

Performance Curves

Torque Characteristics

Measurement at 1000 Steps/Revolution, Nominal Voltage DC Bus U_N and Phase Current I_N

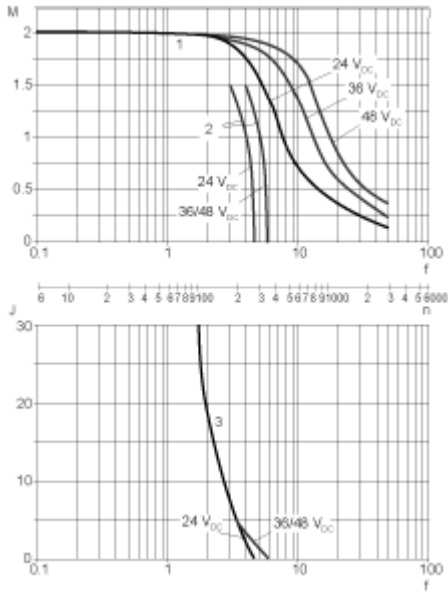

M : Torque in Nm

n : Speed in rpm

f : Frequency in kHz

J : Rotor inertia in kg.cm²

1 : Pull-out torque

2 : Pull-in torque

3 : Maximum load inertia