

Product data sheet

Specifications



Scara robot, Lexium Scara, 600mm arm, 200mm

LXMRSP0660200

Product availability: Non-Stock - Not normally stocked in distribution facility

Main

Range of Product	Lexium SCARA
Product or Component Type	SCARA robot
Permanent permissible load	13.2 lb(US) (6 kg)
Operating travel	0...23.6 in (0...600 mm) horizontal 0...7.9 in (0...200 mm) vertical
Number of axis	4
Repeat accuracy	+/- 0.02 mm J1 +/- 0.02 mm J2 +/- 0.01 mm J3 +/- 0.01 ° J4

Complementary

Operating position	Rotational 360°
Maximum actuation speed	7750 mm/s J1+J2 1100 mm/s J3
Input voltage	170...250 V AC without derating 100...170 V AC with derating of 15%
Angular speed	2150 °/s J4
Mounting Mode	Tabletop
Work space	J1: +/- 130 ° J2: +/- 148 ° J3: 200 mm J4: +/- 360 °
Rated power in W	0.9 kW
Maximum power	2 kW
Noise level	70 dB
rated moment of inertia	0.24 lb.ft ² (0.01 kg.m ²) J4
Maximum moment of inertia	2.85 lb.ft ² (0.12 kg.m ²) J4
Product Weight	61.7 lb(US) (28 kg)

Environment

Ambient air temperature for operation	32...104 °F (0...40 °C)
Ambient air transport temperature	-4...140 °F (-20...60 °C)
Ambient Air Temperature for Storage	-4...140 °F (-20...60 °C)
IP degree of protection	IP20 IP65 with conformity kit)

Price is "List Price" and may be subject to a trade discount – check with your local distributor or retailer for actual price.

Operating altitude	3280.84 ft (1000 m) without derating > 1000...1500 m 10 % derating of performance > 1500...2000 m 20 % derating of performance
Environmental characteristic	Normal environment
resistance to electrostatic discharge	4 kV
resistance to fast transients	2 kV

Ordering and shipping details

Category	US1PC5218357
Discount Schedule	PC52
GTIN	3606487102205
Returnability	No
Country of origin	CN

Packing Units

Unit Type of Package 1	PCE
Nbr. of units in pkg.	1
Package 1 Height	15.9 in (40.5 cm)
Package 1 Width	31.5 in (80 cm)
Package 1 Length	47.2 in (120 cm)
Package weight(Lbs)	112.4 lb(US) (51 kg)

Contractual warranty

Warranty (in months)	18
-----------------------------	----



Environmental Data

Schneider Electric aims to achieve Net Zero status by 2050 through supply chain partnerships, lower impact materials, and circularity via our ongoing “Use Better, Use Longer, Use Again” campaign to extend product lifetimes and recyclability.

[Environmental Data explained >](#)

[How we assess product sustainability >](#)



Environmental footprint

Total lifecycle Carbon footprint	4 397 kg CO2 eq.
Carbon footprint of the manufacturing phase [A1 to A3]	393 kg CO2 eq.
Carbon footprint of the distribution phase [A4]	72 kg CO2 eq.
Carbon footprint of the installation phase [A5]	24 kg CO2 eq.
Carbon footprint of the use phase [B2, B3, B4, B6]	3 860 kg CO2 eq.
Carbon footprint of the end-of-life phase [C1 to C4]	48 kg CO2 eq.
Environmental Disclosure	Product Environmental Profile

Use Better



Materials and Substances

Packaging made with recycled cardboard	Yes
Packaging without single use plastic	Yes
EU RoHS Directive	Compliant By Exemption
REACH Regulation	Reference contains Substances of Very High Concern above the threshold

Use Longer



Lifetime extension

Repair	No
--------	----

Use Again



Repack and remanufacture

Circularity Profile	End of Life Information
Take-back	No

Dimensions Drawings

Dimensional Drawing

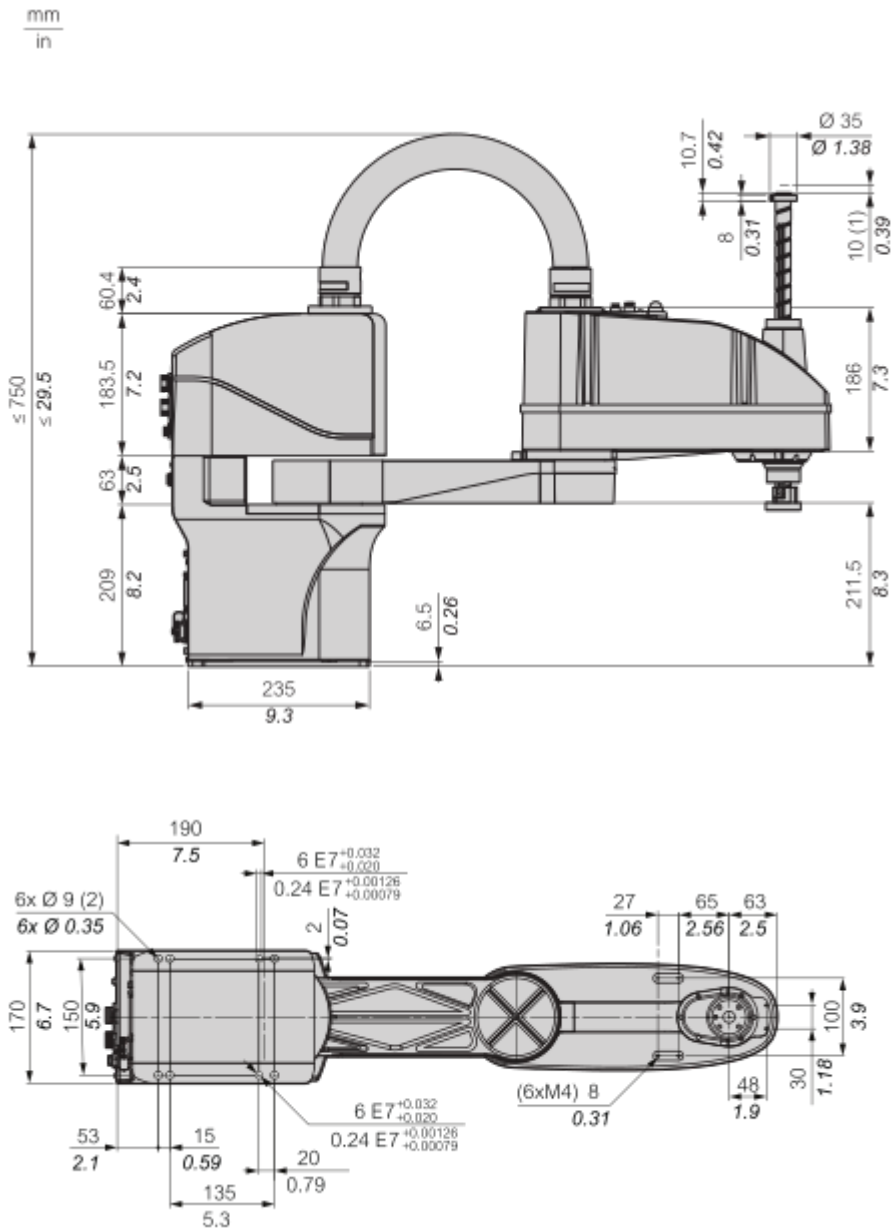

(1) : Screw reaches hard limit position(2) : Mounting holes

Horizontal Workspace

Horizontal workspace of Lexium SCARA with workspace of 600 mm (23.6 in)

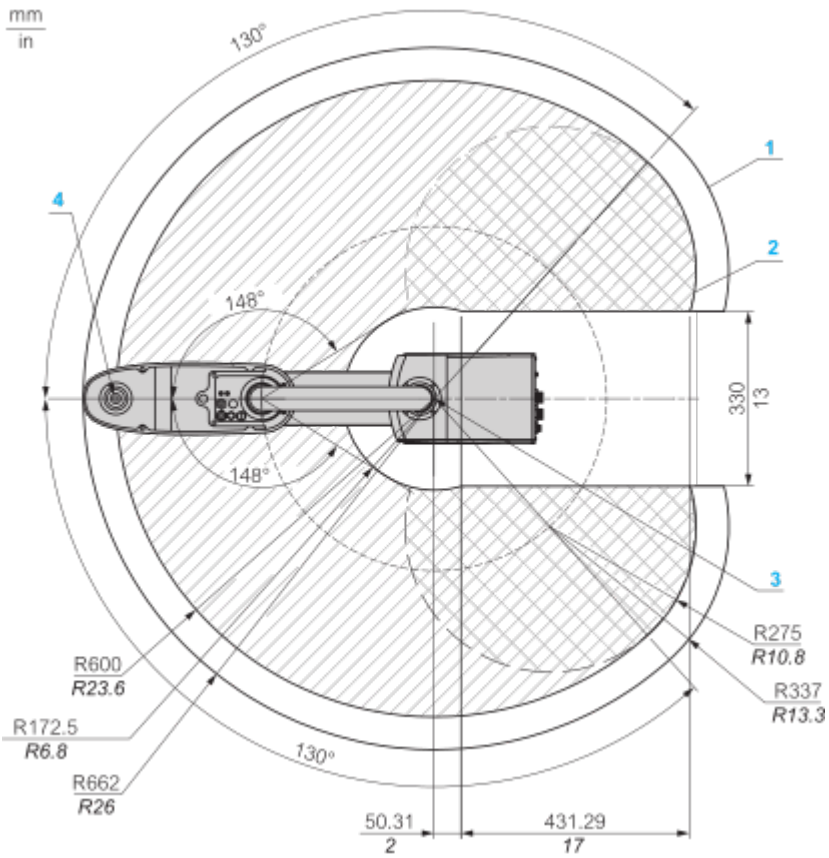

1 : Maximum area 2 : Motion area 3 : Joint 1 rotation center 4 : Joint 3 rotation center

Mounting and Clearance

Mounting the Robot

Base Mounting

Use bolts, elastic washers, and flat washers for base mounting. The dimensions and installation of the bolts and washers are presented in the following figure.

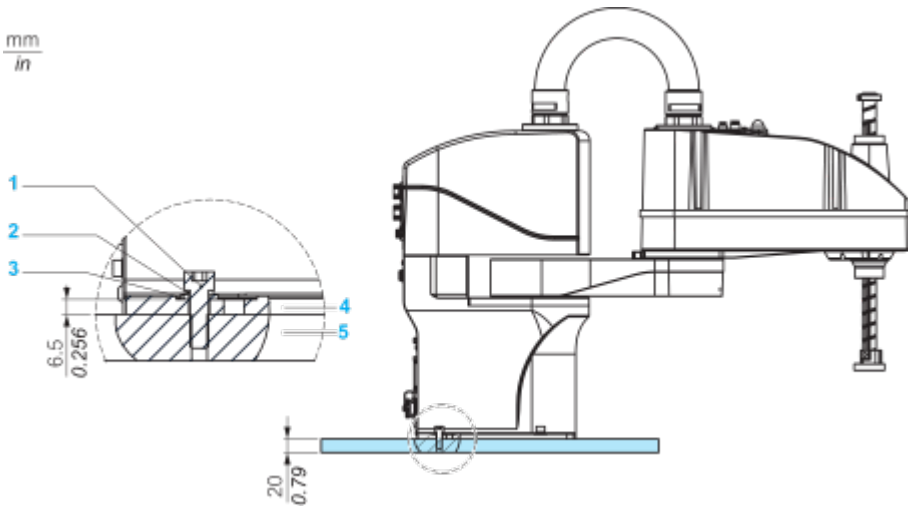

- 1 : Hexagon socket screw M8x25 (4 pieces)
 - 2 : Spring washer
 - 3 : Flat washer
 - 4 : Robot base
 - 5 : Bottom plate
- Position the robot via the two dial-pins and secure the robot base by screwing down four bolts through the mounting holes. Use the hexagon bolts, elastic washers, and flat washers. Torque requirement for base mounting bolt: • 4 securing screws: M8x25 • Torque requirement: 35 Nm (310 lbf-in)

Connections and Schema

Electrical Connections

Interface Panel Overview

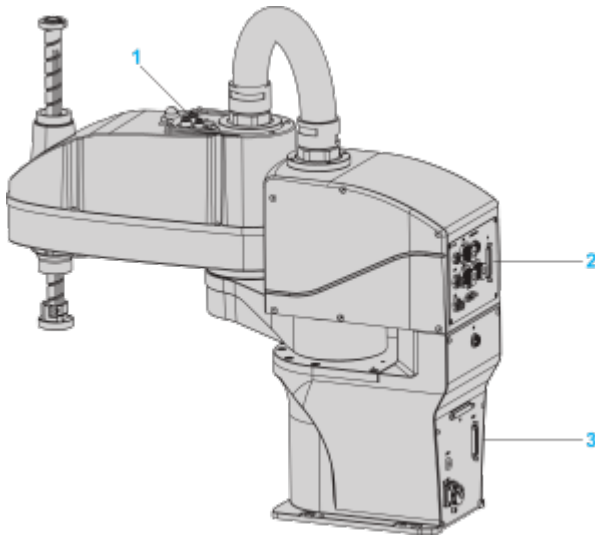

1 : Arm 2 interface panel 2 : Control unit interface panel 3 : Base interface panel

Arm 2 Interface Panel

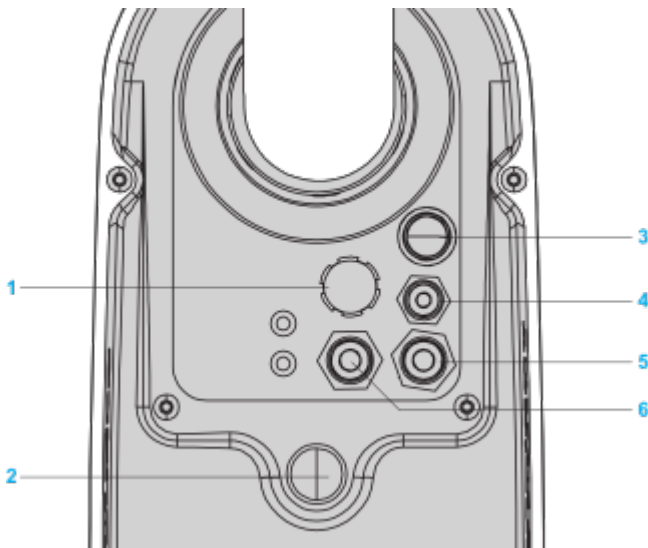

1 **CS**: Customer Signal interface (Customer Signal) 2: Robot Status indicator 3 **Brake**: Brake release button 4 **Air3**: Air hose 3: Ø 4 mm (0.157 in) 5 **Air2**: Air hose 2: Ø 6 mm (0.236 in) 6 **Air1**: Air hose 1: Ø 6 mm (0.236 in)

Control Unit Interface Panel

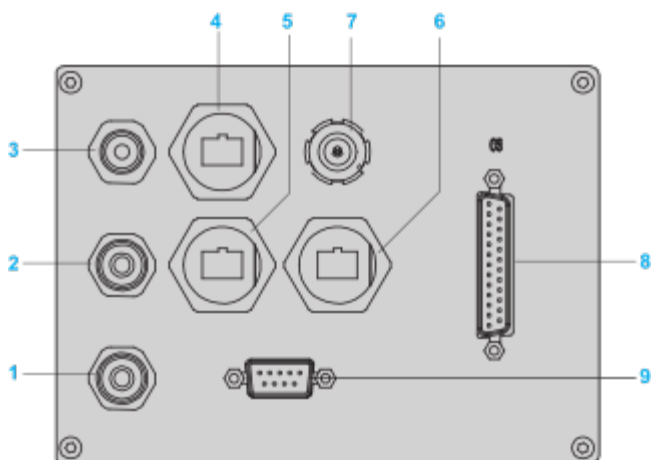

1 Air1 : Air hose 1: Ø 6 mm (0.236 in) 2 Air2 : Air hose 2: Ø 6 mm (0.236 in) 3 Air3 : Air hose 3: Ø 4 mm (0.157 in) 4 RTN1 : Sercos port 1 5 RTN2 : Sercos port 2 6 LAN : Reserved 7 Auxiliary Encoder : Reserved 8 CS : Customer Signal interface (Customer Signal) 9 RS-232 : Reserved

Base Interface Panel

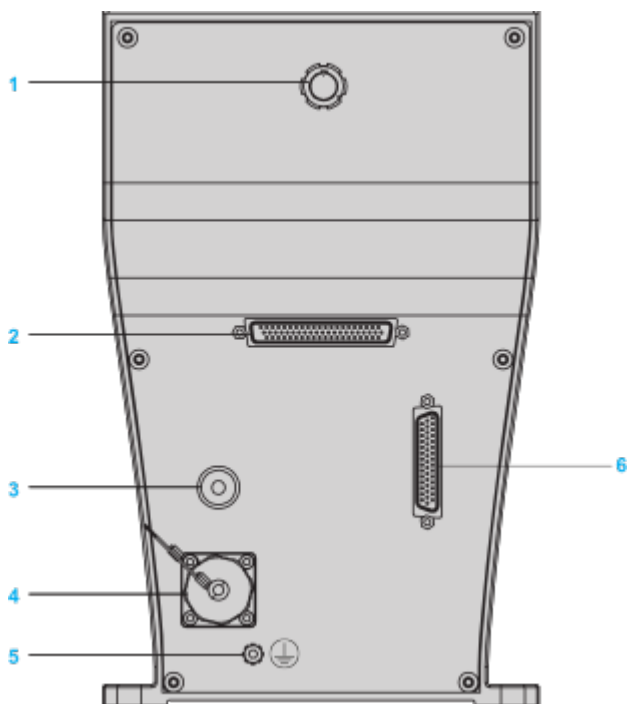

1 MCP: Reserved: use MCP (Manual Control Pendant) jumper plug 2 I/O: Reserved 3 AC LED: Main power indicator light 4 POWER: AC power supply connector 5  : Earth ground connection 6 SAFETY: Emergency stop connector

Emergency Stop Connector (SAFETY)

The emergency stop connector at the robot base is labeled SAFETY. The corresponding pre configured cable is labeled Cable_SAFETY and presented in the figure above. The cable has a D-Sub44 connector and an open end. The minimum bending radius of this cable is 51 mm (2 in).

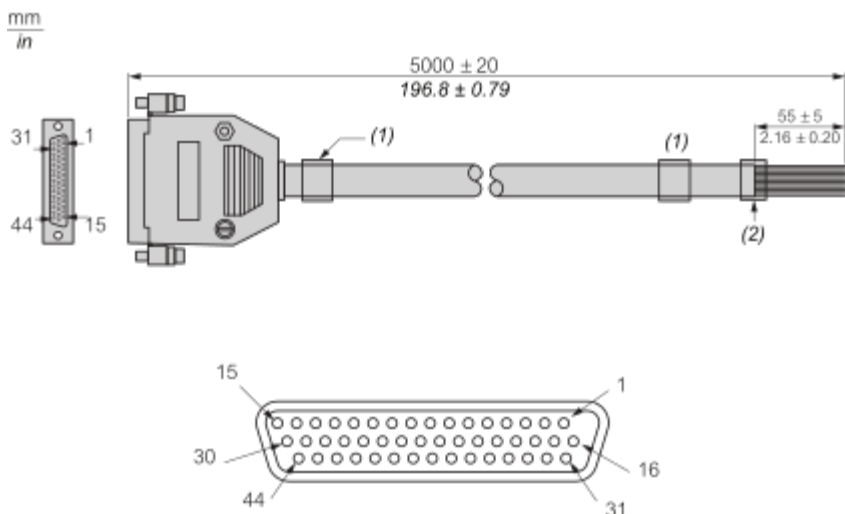

Wiring example with Safety Module XPSUAT•3A3A•

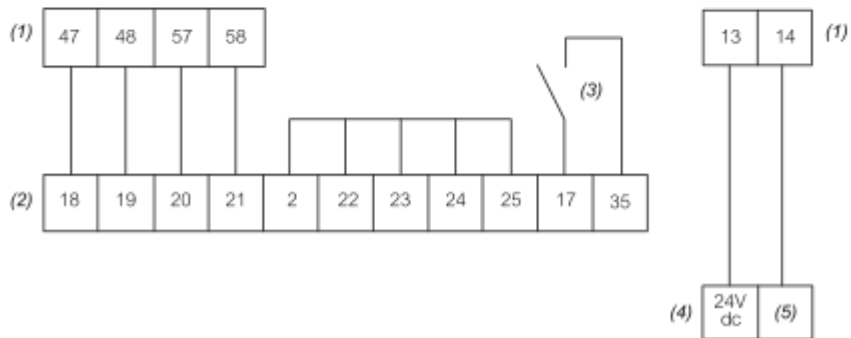
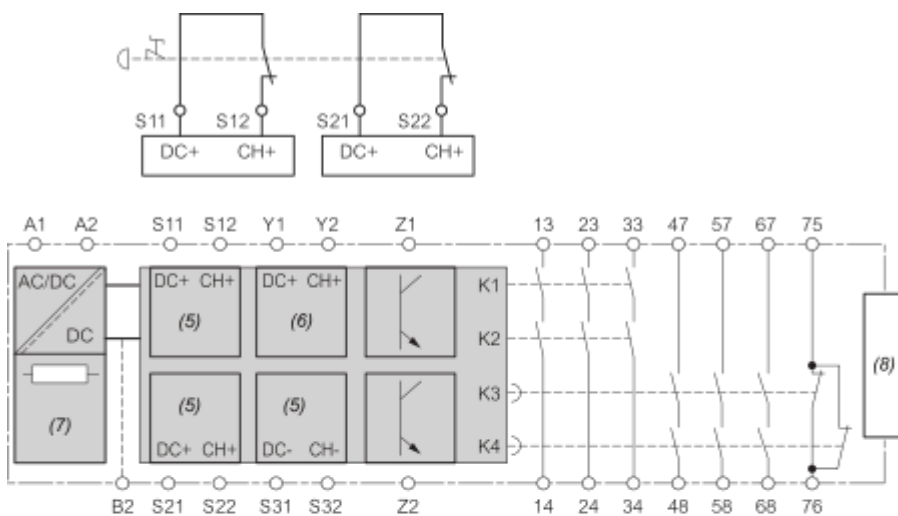

(1) : Safety Module (2) : SCARA —SAFETY (3) : Auto ON (4) : Pac Drive I/O (5) : Pac Drive input (6) : Start (7) : Power Supply (8) : Exit

Pin	Wire color	Function	Description
01	Black	24 V dc	24 V dc output
02	Brown	24 V dc GND	24 V dc grounding potential

03	Red	E-Stop State 1	Emergency stop output 1
04	Orange	E-Stop State 2	Emergency stop output 2
05...12	–	–	Reserved
13,14	–	–	Terminals of the safety module
15	–	–	Reserved
16	Yellow	24 V dc	24 V dc output
17	Green	24 V dc GND	24 V dc grounding potential
18	Blue	E-Stop channel 1A	User emergency stop 1
19	Purple	E-Stop channel 1B	User emergency stop 1
20	Gray	E-Stop channel 2A	User emergency stop 2
21	White	E-Stop channel 2B	User emergency stop 2
22	Pink	Protective Stop channel 1	User protective stop 1
23	White/Black	Protective Stop channel 2	User protective stop 2
24	White/Brown	Functional safety device 1	User functional safety device 1
25	White/Red	Functional safety device 2	User functional safety device 2
26..30	–	–	Reserved
31	White/Orange	24 V dc	24 V dc output
32	White/Yellow	24 V dc GND	24 V dc grounding potential
33, 34	–	–	Reserved
35	White/Purple	Auto_On(1)	Power enable confirmation
36...44	–	–	Reserved
47,48,57,58	–	–	Terminals of the safety module

(1) Before the robot accepts commands from the controller via Sercos, a confirmation is required after the robot has been powered on. For the confirmation pulse, the Auto_On input is used (pin 17 and pin 35, button or...). The Auto_On signal must be considered in the safety assessment.

Image of product / Alternate images

Alternative





