



Side A JAPANESE
Side B ENGLISH

FX3U-16CCL-M

INSTALLATION MANUAL



Manual Number	JY997D43401
Revision	D
Date	September 2017

This manual describes the part names, dimensions, mounting, and specifications of the product. Before use, read this manual and the manuals of all relevant products fully to acquire proficiency in handling and operating the product. Make sure to learn all the product information, safety information, and precautions. Store this manual in a safe place so that it can be taken out and read whenever necessary. Always forward it to the end user.

Registration:
The company and product names described in this manual are registered trademarks or the trademarks of their respective companies.

Effective September 2017
Specifications are subject to change without notice.

© 2011 Mitsubishi Electric Corporation

Safety Precautions (Read these precautions before use.)

This manual classifies the safety precautions into two categories:

WARNING and **CAUTION**

WARNING	Indicates that incorrect handling may cause hazardous conditions, resulting in death or severe injury.
CAUTION	Indicates that incorrect handling may cause hazardous conditions, resulting in medium or slight personal injury or physical damage.

Depending on the circumstances, procedures indicated by **CAUTION** may also cause severe injury. It is important to follow all precautions for personal safety.

Associated Manuals

Manual name	Manual No.	Description
FX3U-16CCL-M User's Manual	JY997D43601 MODEL CODE: 09R724	Describes details of the FX3U-16CCL-M CC-Link master block.
FX3G Series User's Manual - Hardware Edition	JY997D31301 MODEL CODE: 09R521	Explains the FX3G Series PLC specifications for I/O, wiring, installation, and maintenance.
FX3GC Series User's Manual - Hardware Edition	JY997D45401 MODEL CODE: 09R533	Explains the FX3GC Series PLC specifications for I/O, wiring, installation, and maintenance.
FX3U Series User's Manual - Hardware Edition	JY997D16501 MODEL CODE: 09R516	Explains the FX3U Series PLC specifications for I/O, wiring, installation, and maintenance.
FX3UC Series User's Manual - Hardware Edition	JY997D28701 MODEL CODE: 09R519	Explains the FX3UC Series PLC specifications for I/O, wiring, installation, and maintenance.
FX3S/FX3G/FX3GC/FX3U/FX3UC Series Programming Manual - Basic & Applied Instruction Edition	JY997D16601 MODEL CODE: 09R517	Describes PLC programming for basic/applied instructions and devices.
MELSEC iQ-F FX5U User's Manual (Hardware)	JY997D55301 MODEL CODE: 09R536	Explains the FX5U PLC specifications for I/O, wiring, installation, and maintenance.
MELSEC iQ-F FX5UC User's Manual (Hardware)	JY997D61401 MODEL CODE: 09R558	Explains the FX5UC PLC specifications for I/O, wiring, installation, and maintenance.

How to obtain manuals

For product manuals or documents, consult with the Mitsubishi Electric dealer from who you purchased your product.

Certification of UL, cUL standards

FX3U-16CCL-M units comply with the UL standards (UL, cUL).
UL, cUL File Number: E95239

Regarding the standards that comply with the main unit, please refer to either the FX series product catalog or consult with your nearest Mitsubishi product provider.

Compliance with EC directive (CE Marking)

This note does not guarantee that an entire mechanical module produced in accordance with the contents of this note will comply with the following standards. Compliance to EMC directive and LVD directive for the entire mechanical module should be checked by the user / manufacturer. For more information please consult with your nearest Mitsubishi product provider.

Regarding the standards that comply with the main unit, please refer to either the FX series product catalog or consult with your nearest Mitsubishi product provider.

Requirement for Compliance with EMC directive

The following products have shown compliance through direct testing (of the identified standards below) and design analysis (through the creation of a technical construction file) to the European Directive for Electromagnetic Compatibility (2014/30/EU) when used as directed by the appropriate documentation.

Attention

This product is designed for use in industrial applications.

Type: Programmable Controller (Open Type Equipment)
Models: MELSEC FX3U series manufactured

from August 1st, 2011 FX3U-16CCL-M

Standard	Remark
EN61131-2:2007 Programmable controllers - Equipment requirements and tests	Compliance with all relevant aspects of the standard. EMI • Radiated Emission • Conducted Emission EMS • Radiated electromagnetic field • Fast transient burst • Electrostatic discharge • High-energy surge • Voltage drops and interruptions • Conducted RF • Power frequency magnetic field

Caution for EC Directive

• Installation in Enclosure
Programmable controllers are open-type devices that must be installed and used within conductive control cabinets. Please use the programmable controller while installed within a conductive shielded control cabinet. Please secure the cabinet door to the control cabinet (for conduction). Installation within a control cabinet greatly affects the safety of the system and aids in shielding noise from the programmable controller.

• Control cabinet

- The control cabinet must be conductive.
- Ground the control cabinet with the thickest possible grounding cable.
- To ensure that there is electric contact between the control cabinet and its door, connect the cabinet and its doors with thick wires.
- In order to suppress the leakage of radio waves, the control cabinet structure must have minimal openings. Also, wrap the cable holes with a shielding cover or other shielding devices.
- The gap between the control cabinet and its door must be as small as possible by attaching EMI gaskets between them.

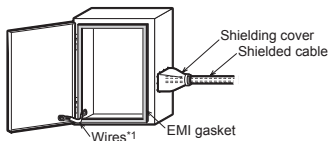

*1 These wires are used to improve the conductivity between the door and control cabinet.

• Configuration example inside control cabinet

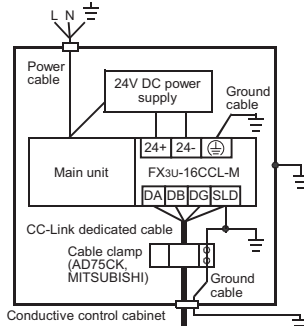

• Wiring simplified diagram

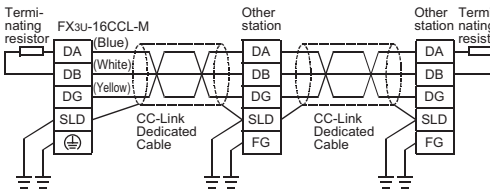

• Notes for compliance with EN61131-2:2007

- General notes on the use of the power supply cable.
- The FX3U-16CCL-M unit requires that the cable used for power supply is 30 m or less.
 - When the cable used for power supply exceeds 30 m, a noise filter (Ex. TDK-Lambda MBS1205-22 or similar) should be placed on the 24 V DC power cabling as close (within 500 mm) to the FX3U-16CCL-M termination points as possible, refer to following figure.

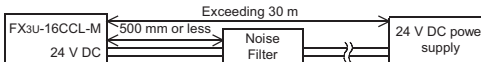

1. Introduction

The CC-Link master block FX3U-16CCL-M is a special function block which assigns an FX3G/FX3GC/FX3U/FX3UC/FX5U/FX5UC PLC as the master station of a CC-Link system. Only one FX3U-16CCL-M unit can be connected to a single programmable controller main unit.

→ For details, refer to the FX3U-16CCL-M User's Manual.

1.1 Major Features of the FX3U-16CCL-M

- Compatible with CC-Link Ver. 2.00 and Ver. 1.10
The FX3U-16CCL-M is compatible with CC-Link Ver. 2.00, and enables expanded cyclic transmission to facilitate the handling of applications requiring multiple points of data processing. In addition to Ver. 2.00, Ver. 1.10 is also supported by the FX3U-16CCL-M.
 - The FX3U-16CCL-M supports connection of intelligent device stations
Remote I/O stations, remote device stations and intelligent device station can also be connected to the FX3U-16CCL-M.
- [Caution]**
Local stations can not be connected.

1.2 Incorporated Items

Check to ensure the following product and items are included in the package.

Included Item		
FX3U-16CCL-M		1 unit
Special unit/block No. label		1 sheet
Terminal resistor	For CC-Link dedicated cable 110 Ω 1/2 W (color cable: brown, brown and brown)	2 cables
	For CC-Link dedicated high-performance cable 130 Ω 1/2 W (color cable: brown, orange and brown)	2 cables
Dust proof protection sheet		1 sheet
Manuals (Japanese version, English version)		1 manual each

1.3 External Dimensions and Part Names

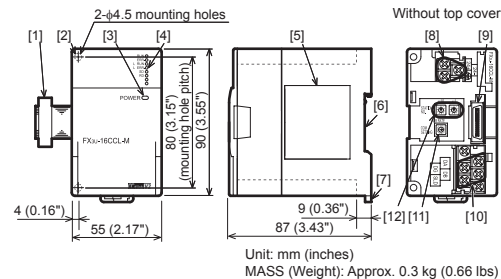

[1] Extension cable	[7] DIN rail mounting hook
[2] Direct mounting hole 2 holes of φ4.5 (0.18") (mounting screw: M4 screw)	[8] Power supply terminal block
[3] Power LED (green)	[9] Extension connector
[4] Status LEDs	[10] CC-Link connection terminal block
[5] Name plate	[11] Transmission rate setting switch
[6] DIN rail mounting groove (DIN rail: DIN46277, 35 mm (1.38") width)	[12] Station number setting switch

1.4 Power and status LEDs

LED display	LED Color	Status	Description
POWER	Green	OFF	Power is not being supplied from the external power supply (24 V DC).
		ON	Power is being supplied from the external power supply (24 V DC).
RUN	Green	OFF	FX3U-16CCL-M has failed.
		ON	Under FX3U-16CCL-M normal operation.
ERR.	Red	OFF	No errors.
		Flicker	Communication error has occurred in some stations.
L RUN	Green	OFF	Offline.
		ON	Data link is being executed (host station).
L ERR.	Red	OFF	No communication error.
		Flicker	The switch setting was changed after start. There is no terminating resistor. Influence from noise.
SD	Green	OFF	Data is not being sent.
		ON	Data is being sent.
RD	Green	OFF	Data is not being received.
		ON	Data is being received.

1.5 Terminal Layout

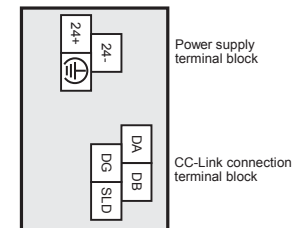

- Terminal screw and terminal block mounting screw size, and tightening torque
Power supply terminal block, CC-Link connection terminal block:
M3 screw, 0.42 to 0.58 N•m
CC-Link connection terminal block mounting screw (black):
M3.5 screw, 0.66 to 0.91 N•m

Do not tighten the terminal block mounting screws with a torque outside the above-mentioned range.

Failure to do so may cause equipment failures or malfunctions.

CC-Link connection terminal block can be detached or attached. Make sure to cut off all phases of the power supply externally.

For details on the wiring and the types of connection cables needed to connect to the terminal blocks shown in the figure above, refer to the following manual.

→ Refer to the FX3U-16CCL-M User's Manual.

1.6 Switch setting

With regard to the switch setting for station number, transmission rate, line test, hardware test, the switch settings become valid after FX3U-16CCL-M startup. If the switch settings are changed after FX3U-16CCL-M startup, the L ERR. LED will flicker.

To change the switch setting, power OFF the FX3U-16CCL-M once, and power it ON again.

For details on the switch setting, refer to the following manual.

→ Refer to the FX3U-16CCL-M User's Manual.

1.6.1 Station number setting

Setting items	Range	Description
× 10	0,1	Online: 0 (Master station) Line test: 0 to 16 17 to 99 is the setting error.
× 1	0 to 9	

1.6.2 Transmission rate setting, line test, hardware test

Setting	Description	Status
0	Transmission rate 156 Kbps	Online
1	Transmission rate 625 Kbps	
2	Transmission rate 2.5 Mbps	
3	Transmission rate 5 Mbps	
4	Transmission rate 10 Mbps	Line test <ul style="list-style-type: none"> When the station number setting switch is 0: Line test 1 When the station number setting switch is 1 to 16: Line test 2
5	Transmission rate 156 Kbps	
6	Transmission rate 625 Kbps	
7	Transmission rate 2.5 Mbps	
8	Transmission rate 5 Mbps	
9	Transmission rate 10 Mbps	
A	Transmission rate 156 Kbps	Hardware test
B	Transmission rate 625 Kbps	
C	Transmission rate 2.5 Mbps	
D	Transmission rate 5 Mbps	
E	Transmission rate 10 Mbps	
F	Unusable	

2. Installation

For details on installation, refer to the following manual.

→ Refer to the FX3U-16CCL-M User's Manual.

INSTALLATION PRECAUTIONS	WARNING
<ul style="list-style-type: none"> Make sure to cut off all phases of the power supply externally before attempting installation work. Failure to do so may cause electric shock or damage to the product. 	

INSTALLATION PRECAUTIONS	CAUTION
<ul style="list-style-type: none"> Use the product within the generic environment specifications described in PLC main unit manual (Hardware Edition). Never use the product in areas with excessive dust, oily smoke, conductive dusts, corrosive gas (salt air, Cl₂, H₂S, SO₂ or NO₂), flammable gas, vibration or impacts, or expose it to high temperature, condensation, or rain and wind. If the product is used in such conditions, electric shock, fire, malfunctions, deterioration or damage may occur. Do not touch the conductive parts of the product directly. Doing so may cause device failures or malfunctions. Install the product securely using a DIN rail or mounting screws. Install the product on a flat surface. If the mounting surface is rough, undue force will be applied to the PC board, thereby causing nonconformities. When drilling screw holes or wiring, make sure or cutting or wire debris does not enter the ventilation slits. Failure to do so may cause fire, equipment failures or malfunctions. Be sure to remove the dust proof sheet from the PLC's ventilation slits when installation work is completed. Failure to do so may cause fire, equipment failures or malfunctions. Make sure to attach the top cover, offered as an accessory, before turning on the power or initiating operation after installation or wiring work. Failure to do so may cause electric shock. Connect extension cables securely to their designated connectors. Loose connections may cause malfunctions. 	

2.1 Connection with PLC

Only one FX3U-16CCL-M can be connected to the right side of a PLC main unit or extension unit/block (including special function units/blocks).

For connection to an FX3G/FX3UC Series PLC or FX2NC Series extension block, an FX2NC-CNV-IF or FX3UC-1PS-5V is required.

For connection to FX5U/FX5UC PLC, FX5-CNV-BUS or FX5-CNV-BUSC is required.

For details, refer to the respective PLC manual.

- Refer to the FX3G Series User's Manual - Hardware Edition.
- Refer to the FX3GC Series User's Manual - Hardware Edition.
- Refer to the FX3U Series User's Manual - Hardware Edition.
- Refer to the FX3UC Series User's Manual - Hardware Edition.
- Refer to the MELSEC IQ-F FX5U User's Manual (Hardware).
- Refer to the MELSEC IQ-F FX5UC User's Manual (Hardware).

2.2 Mounting

The product is mounted by the following method.

- DIN rail mounting
- Direct mounting (mounting screw: M4 screw)

For details, refer to the respective PLC manual.

- Refer to the FX3G Series User's Manual - Hardware Edition.
- Refer to the FX3GC Series User's Manual - Hardware Edition.
- Refer to the FX3U Series User's Manual - Hardware Edition.
- Refer to the FX3UC Series User's Manual - Hardware Edition.
- Refer to the MELSEC IQ-F FX5U User's Manual (Hardware).
- Refer to the MELSEC IQ-F FX5UC User's Manual (Hardware).

3. Specification

For details on specifications, refer to the following manual.

→ Refer to the FX3U-16CCL-M User's Manual.

DESIGN PRECAUTIONS	WARNING
<ul style="list-style-type: none"> When executing control (data changes) to an operating PLC, construct an interlock circuit in the sequence program so that the entire system operates conservatively. Additionally, when executing control such as program changes and operation status changes (status control) to an operating PLC, thoroughly read the manual and sufficiently confirm safety in advance. Especially in control from external equipment to a PLC in a remote place, problems in the PLC may not be able to be handled promptly due to abnormality in data transfer. Construct an interlock circuit in the sequence program. At the same time, determine the actions in the system between the external equipment and the PLC for protection against abnormalities in data transfer. Make sure to have the following safety circuits outside the PLC to ensure safe system operation even during external power supply problems or PLC failure. Otherwise, malfunctions may cause serious accidents. <ol style="list-style-type: none"> Most importantly, have the following: an emergency stop circuit, a protection circuit, an interlock circuit for opposite movements (such as normal vs. reverse rotation), and an interlock circuit (to prevent damage to the equipment at the upper and lower positioning limits). Note that when the PLC CPU detects an error, such as a watchdog timer error, during self-diagnosis, all outputs are turned off. Also, when an error that cannot be detected by the PLC CPU occurs in an input/output control block, output control may be disabled. External circuits and mechanisms should be designed to ensure safe machinery operation in such a case. 	

DESIGN PRECAUTIONS	CAUTION
<ul style="list-style-type: none"> Make sure to observe the following precautions in order to prevent any damage to the machinery or accidents due to abnormal data written to the PLC under the influence of noise: <ol style="list-style-type: none"> Do not bundle the control line together with or lay it close to the main circuit or power line. As a guideline, lay the control line at least 100 mm (3.94") or more away from the main circuit or power line. Noise may cause malfunctions. Ground the shield wire or shield of a shielded cable. Do not use common grounding with heavy electrical systems. Install module so that excessive force will not be applied to the power supply terminal block or CC-Link connection terminal block. Failure to do so may result in wire damage/breakage or PLC failure.	

DISPOSAL PRECAUTIONS	CAUTION
<ul style="list-style-type: none"> Please contact a certified electronic waste disposal company for the environmentally safe recycling and disposal of your device. 	

TRANSPORTATION AND STORAGE PRECAUTIONS	CAUTION
<ul style="list-style-type: none"> The PLC is a precision instrument. During transportation, avoid impacts larger than those specified in the general specifications of the PLC main unit manual by using dedicated packaging boxes and shock-absorbing pallets. Failure to do so may cause failures in the PLC. After transportation, verify operation of the PLC and check for damage of the mounting part, etc.	

3.1 Applicable PLC

Model name	Applicability
FX3G Series PLC	Ver. 1.00 and later ^{*3} Only one FX3U-16CCL-M unit can be connected in a main unit.
FX3GC Series PLC	Ver. 1.40 and later ^{*3} Only one FX3U-16CCL-M unit can be connected in a main unit.
FX3U Series PLC	Ver. 2.20 and later ^{*3} Only one FX3U-16CCL-M unit can be connected in a main unit.
FX3UC Series PLC ^{*1}	Ver. 2.20 and later ^{*3} Only one FX3U-16CCL-M unit can be connected in a main unit.
FX5U PLC ^{*2}	From first production Only one FX3U-16CCL-M unit can be connected in a CPU module.
FX5UC PLC ^{*2}	From first production Only one FX3U-16CCL-M unit can be connected in a CPU module.

*1 An FX2NC-CNV-IF or FX3UC-1PS-5V is necessary to connect the FX3U-16CCL-M with the FX3G/FX3UC PLC.

*2 An FX5-CNV-BUS or FX5-CNV-BUSC is necessary to connect the FX3U-16CCL-M with the FX5U/FX5UC PLC.

*3 The version number can be checked by reading the last three digits of device D8001/D8101.

3.2 General Specifications

Items other than the following are equivalent to those of the PLC main unit.

For general specifications, refer to the manual of the PLC main unit.

- Refer to the FX3G Series User's Manual - Hardware Edition.
- Refer to the FX3GC Series User's Manual - Hardware Edition.
- Refer to the FX3U Series User's Manual - Hardware Edition.
- Refer to the FX3UC Series User's Manual - Hardware Edition.
- Refer to the MELSEC IQ-F FX5U User's Manual (Hardware).
- Refer to the MELSEC IQ-F FX5UC User's Manual (Hardware).

Item	Specification	
Dielectric withstand voltage	500 V AC for one minute	Between all terminals and ground terminal
Insulation resistance	5 MΩ or higher by 500 V DC insulation resistance tester	

3.3 Power Supply Specification

Item	Specification	
External power supply	Power supply voltage	24 V DC +20% -15% Ripple (p-p) within 5%
	Permitted instantaneous power failure time	Operation continues when the instantaneous power failure is shorter than PS1:1 ms.
	Current consumption	240mA
Internal power supply	Power supply voltage	5 V DC of PLC is not used. (5 V DC is converted from 24 V DC external power supply.)
	Current consumption	Make sure to observe the power-on timing and the procedure.

3.4 Performance Specification

Item	Specification
Applicable function	Master station function (The local station and standby master station functions are not provided.)
CC-Link applicable version	Ver. 2.00 (Ver. 1.10 also supported.)
Station number	0 (set by rotary switch)
Transmission rate	156 Kbps/625 Kbps/2.5 Mbps/5 Mbps/10 Mbps (set by rotary switch)
Maximum total cable length (maximum transmission distance)	1,200 m maximum (varies depending on the transmission speed.) For details, refer to the FX3U-16CCL-M User's Manual.
Connection cable ^{*1}	CC-Link dedicated cable/ CC-Link dedicated high-performance cable/ Ver. 1.10 compatible CC-Link dedicated cable
Maximum number of connectable stations	1) Remote I/O stations: 8 maximum (Each station occupies 32 I/O points of the PLC.) 2) Remote device stations + Intelligent device stations: 8 maximum (The total number of RX/RX points is 256 or less.)
Maximum number of I/O points per system	When using an FX3U/FX3UC/FX5U/FX5UC PLC 1) + 2) total number of points ≤ 384 points 1) (Actual number of PLC I/O points) + (Number of points occupied by special function blocks) + (Number of points occupied by the FX3U-16CCL-M: 8 points) ≤ 256 points 2) 32 × Number of remote I/O stations ≤ 256 points When using an FX3G/FX3GC PLC 32 × Number of remote I/O stations ≤ 128 points
Number of link points per station ^{*2}	Remote I/O (RX, RY): 32 points Remote register (RWw): 4 points (Master station → Remote device station/ intelligent device station) Remote register (RWr): 4 points (Remote device station/intelligent device station) → Master station)
Communication with PLC ^{*3}	By FROM and TO instructions or direct specification of buffer memory (FX3U/FX3UC) via the buffer memory.
Number of I/O occupied points	8 points
Number of connectable units to the main unit	1 (An FX3U-16CCL-M cannot be attached to main unit with an FX2N-16CCL-M.)

*1 CC-Link dedicated cables, Ver. 1.10 compatible CC-Link dedicated cable and CC-Link dedicated high-performance cable cannot be used together. Also attach the terminating resistor which matches the kind of the cable.

*2 Indicates the number of link points for remote net. Ver. 1 mode. For the number of link points for remote net. Ver. 2 mode/remote net additional mode, refer to the FX3U-16CCL-M User's Manual.

*3 For details of other applied instructions and methods, refer to the FX3S/FX3G/FX3GC/FX3U/FX3UC Programming Manual.

「电器电子产品有害物质限制使用标识要求」的表示方式



Note: This symbol mark is for China only.

含有有害6物质的名称, 含有量, 含有部品

本产品中所含有的有害6物质的名称, 含有量, 含有部品如下表所示。

		产品中有害物质的名称及含量					
		有害物质					
部件名称		铅 (Pb)	汞 (Hg)	镉 (Cd)	六价铬 (Cr (VI))	多溴联苯 (PBB)	多溴二苯醚 (PBDE)
可编程控制器	外壳	○	○	○	○	○	○
	印刷基板	×	○	○	○	○	○

本表格依据SJ/T 11364的规定编制。

○:表示该有害物质在该部件所有均质材料中的含量均在GB/T 26572

规定的限量要求以下。

×:表示该有害物质至少在该部件的某一均质材料中的含量超出GB/T 26572规定的限量要求。

This manual confers no industrial property rights or any rights of any other kind, nor does it confer any patent licenses. Mitsubishi Electric Corporation cannot be held responsible for any problems involving industrial property rights which may occur as a result of using the contents noted in this manual.

Warranty

Exclusion of loss in opportunity and secondary loss from warranty liability
Regardless of the gratis warranty term, Mitsubishi shall not be liable for compensation to:
(1) Damages caused by any cause found not to be the responsibility of Mitsubishi.
(2) Loss in opportunity, lost profits incurred to the user by Failures of Mitsubishi products.
(3) Special damages and secondary damages whether foreseeable or not, compensation for accidents, and compensation for damages to products other than Mitsubishi products.
(4) Replacement by the user, maintenance of on-site equipment, start-up test run and other tasks.

For safe use
<ul style="list-style-type: none"> This product has been manufactured as a general-purpose part for general industries, and has not been designed or manufactured to be incorporated in a device or system used in purposes related to human life. Before using the product for special purposes such as nuclear power, electric power, aerospace, medicine or passenger movement vehicles, consult with Mitsubishi Electric. This product has been manufactured under strict quality control. However when installing the product where major accidents or losses could occur if the product fails, install appropriate backup or failsafe functions in the system.

MITSUBISHI ELECTRIC CORPORATION

HEAD OFFICE : TOKYO BUILDING, 2-7-3 MARUNOUCHI, CHIYODA-KU, TOKYO 100-8310, JAPAN



Programmable Controller
MELSEC-F

Side A JAPANESE
Side B ENGLISH

FX3U-16CCL-M INSTALLATION MANUAL



Manual Number	JY997D43401
Revision	D
Date	September 2017

This manual describes the part names, dimensions, mounting, and specifications of the product. Before use, read this manual and the manuals of all relevant products fully to acquire proficiency in handling and operating the product. Make sure to learn all the product information, safety information, and precautions. Store this manual in a safe place so that it can be taken out and read whenever necessary. Always forward it to the end user.

Registration:
The company and product names described in this manual are registered trademarks or the trademarks of their respective companies.

Effective September 2017
Specifications are subject to change without notice.
© 2011 Mitsubishi Electric Corporation

Safety Precautions (Read these precautions before use.)

This manual classifies the safety precautions into two categories:

WARNING and **CAUTION**.

WARNING	Indicates that incorrect handling may cause hazardous conditions, resulting in death or severe injury.
CAUTION	Indicates that incorrect handling may cause hazardous conditions, resulting in medium or slight personal injury or physical damage.

Depending on the circumstances, procedures indicated by **CAUTION** may also cause severe injury. It is important to follow all precautions for personal safety.

Associated Manuals

Manual name	Manual No.	Description
FX3U-16CCL-M User's Manual	JY997D43601 MODEL CODE: 09R724	Describes details of the FX3U-16CCL-M CC-Link master block.
FX3G Series User's Manual - Hardware Edition	JY997D31301 MODEL CODE: 09R521	Explains the FX3G Series PLC specifications for I/O, wiring, installation, and maintenance.
FX3GC Series User's Manual - Hardware Edition	JY997D45401 MODEL CODE: 09R533	Explains the FX3GC Series PLC specifications for I/O, wiring, installation, and maintenance.
FX3U Series User's Manual - Hardware Edition	JY997D16501 MODEL CODE: 09R516	Explains the FX3U Series PLC specifications for I/O, wiring, installation, and maintenance.
FX3UC Series User's Manual - Hardware Edition	JY997D28701 MODEL CODE: 09R519	Explains the FX3UC Series PLC specifications for I/O, wiring, installation, and maintenance.
FX3S/FX3G/FX3GC/FX3U/FX3UC Series Programming Manual - Basic & Applied Instruction Edition	JY997D16601 MODEL CODE: 09R517	Describes PLC programming for basic/applied instructions and devices.
MELSEC IQ-F FX5U User's Manual (Hardware)	JY997D55301 MODEL CODE: 09R536	Explains the FX5U PLC specifications for I/O, wiring, installation, and maintenance.
MELSEC IQ-F FX5UC User's Manual (Hardware)	JY997D61401 MODEL CODE: 09R558	Explains the FX5UC PLC specifications for I/O, wiring, installation, and maintenance.

How to obtain manuals

For product manuals or documents, consult with the Mitsubishi Electric dealer from who you purchased your product.

Certification of UL, cUL standards

FX3U-16CCL-M units comply with the UL standards (UL, cUL).
UL, cUL File Number: E95239
Regarding the standards that comply with the main unit, please refer to either the FX series product catalog or consult with your nearest Mitsubishi product provider.

Compliance with EC directive (CE Marking)

This note does not guarantee that an entire mechanical module produced in accordance with the contents of this note will comply with the following standards. Compliance with EMC directive and LVD directive for the entire mechanical module should be checked by the user / manufacturer. For more information please consult with your nearest Mitsubishi product provider.
Regarding the standards that comply with the main unit, please refer to either the FX series product catalog or consult with your nearest Mitsubishi product provider.

Requirement for Compliance with EMC directive

The following products have shown compliance through direct testing (of the identified standards below) and design analysis (through the creation of a technical construction file) to the European Directive for Electromagnetic Compatibility (2014/30/EU) when used as directed by the appropriate documentation.

Attention

This product is designed for use in industrial applications.

Type: Programmable Controller (Open Type Equipment)
Models: MELSEC FX3U series manufactured

Standard	Remark
EN61131-2:2007 Programmable controllers - Equipment requirements and tests	Compliance with all relevant aspects of the standard. EMI • Radiated Emission • Conducted Emission EMS • Radiated electromagnetic field • Fast transient burst • Electrostatic discharge • High-energy surge • Voltage drops and interruptions • Conducted RF • Power frequency magnetic field

Caution for EC Directive

Installation in Enclosure
Programmable controllers are open-type devices that must be installed and used within conductive control cabinets. Please use the programmable controller while installed within a conductive shielded control cabinet. Please secure the cabinet door to the control cabinet (for conduction). Installation within a control cabinet greatly affects the safety of the system and aids in shielding noise from the programmable controller.

Control cabinet

- The control cabinet must be conductive.
- Ground the control cabinet with the thickest possible grounding cable.
- To ensure that there is electric contact between the control cabinet and its door, connect the cabinet and its doors with thick wires.
- In order to suppress the leakage of radio waves, the control cabinet structure must have minimal openings. Also, wrap the cable holes with a shielding cover or other shielding devices.
- The gap between the control cabinet and its door must be as small as possible by attaching EMI gaskets between them.

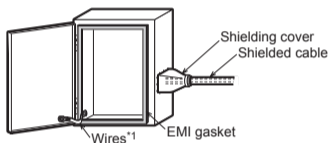

*1 These wires are used to improve the conductivity between the door and control cabinet.

Configuration example inside control cabinet

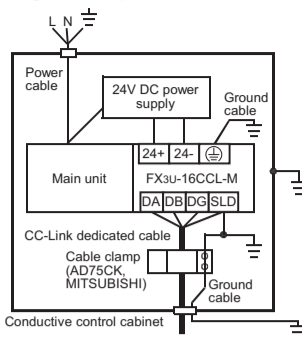

Wiring simplified diagram

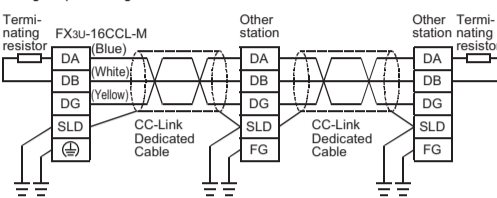

Notes for compliance with EN61131-2:2007

- General notes on the use of the power supply cable.
- The FX3U-16CCL-M unit requires that the cable used for power supply is 30 m or less.
- When the cable used for power supply exceeds 30 m, a noise filter (Ex. TDK-Lambda MBS1205-22 or similar) should be placed on the 24 V DC power cabling as close (within 500 mm) to the FX3U-16CCL-M termination points as possible, refer to following figure.

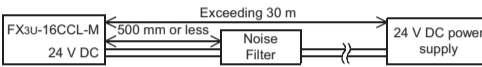

1. Introduction

The CC-Link master block FX3U-16CCL-M is a special function block which assigns an FX3G/FX3GC/FX3U/FX3UC/FX5U/FX5UC PLC as the master station of a CC-Link system. Only one FX3U-16CCL-M unit can be connected to a single programmable controller main unit.

→ For details, refer to the FX3U-16CCL-M User's Manual.

1.1 Major Features of the FX3U-16CCL-M

- Compatible with CC-Link Ver. 2.00 and Ver. 1.10
The FX3U-16CCL-M is compatible with CC-Link Ver. 2.00, and enables expanded cyclic transmission to facilitate the handling of applications requiring multiple points of data processing.
In addition to Ver. 2.00, Ver. 1.10 is also supported by the FX3U-16CCL-M.
- The FX3U-16CCL-M supports connection of intelligent device stations
Remote I/O stations, remote device stations and intelligent device station can also be connected to the FX3U-16CCL-M.

1.2 Incorporated Items

Check to ensure the following product and items are included in the package.

Included Item	Quantity
FX3U-16CCL-M	1 unit
Special unit/block No. label	1 sheet
Terminal resistor	For CC-Link dedicated cable 110 Ω 1/2 W (color cable: brown, brown and brown) 2 cables For CC-Link dedicated high-performance cable 130 Ω 1/2 W (color cable: brown, orange and brown) 2 cables
Dust proof protection sheet	1 sheet
Manuals (Japanese version, English version)	1 manual each

1.3 External Dimensions and Part Names

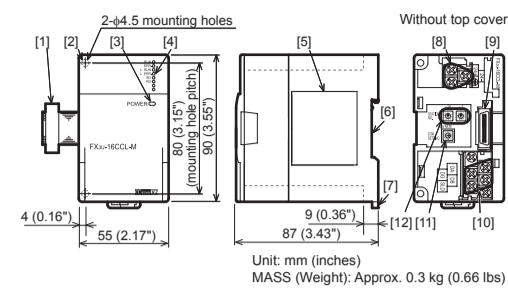

- | | |
|---|--|
| [1] Extension cable | [7] DIN rail mounting hook |
| [2] Direct mounting hole
2 holes of φ4.5 (0.18")
(mounting screw: M4 screw) | [8] Power supply terminal block |
| [3] Power LED (green) | [9] Extension connector |
| [4] Status LEDs | [10] CC-Link connection terminal block |
| [5] Name plate | [11] Transmission rate setting switch |
| [6] DIN rail mounting groove
(DIN rail: DIN46277,
35 mm (1.38") width) | [12] Station number setting switch |

1.4 Power and status LEDs

LED display	LED Color	Status	Description
POWER	Green	OFF	Power is not being supplied from the external power supply (24 V DC).
		ON	Power is being supplied from the external power supply (24 V DC).
RUN	Green	OFF	FX3U-16CCL-M has failed.
		ON	Under FX3U-16CCL-M normal operation.
ERR.	Red	OFF	No errors.
		Flicker	Communication error has occurred in some stations.
		ON	Communication error has occurred in all stations, error in the settings, error in the parameter details, error with the communication, error with the H/W.
L RUN	Green	OFF	Offline.
		ON	Data link is being executed (host station).
L ERR.	Red	OFF	No communication error.
		Flicker	The switch setting was changed after start. There is no terminating resistor. Influence from noise.
		ON	There is a data linking error (host station). There is a setting error.
SD	Green	OFF	Data is not being sent.
		ON	Data is being sent.
RD	Green	OFF	Data is not being received.
		ON	Data is being received.

1.5 Terminal Layout

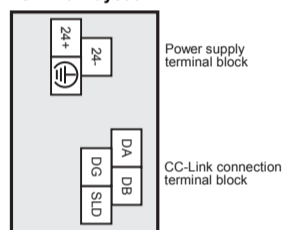

- Terminal screw and terminal block mounting screw size, and tightening torque
Power supply terminal block, CC-Link connection terminal block:
M3 screw, 0.42 to 0.58 N•m
CC-Link connection terminal block mounting screw (black):
M3.5 screw, 0.66 to 0.91 N•m

Do not tighten the terminal block mounting screws with a torque outside the above-mentioned range.

Failure to do so may cause equipment failures or malfunctions.
CC-Link connection terminal block can be detached or attached. Make sure to cut off all phases of the power supply externally.

For details on the wiring and the types of connection cables needed to connect to the terminal blocks shown in the figure above, refer to the following manual.
→ Refer to the FX3U-16CCL-M User's Manual.

1.6 Switch setting

With regard to the switch setting for station number, transmission rate, line test, hardware test, the switch settings become valid after FX3U-16CCL-M startup.
If the switch settings are changed after FX3U-16CCL-M startup, the L ERR. LED will flicker.

To change the switch setting, power OFF the FX3U-16CCL-M once, and power it ON again.
For details on the switch setting, refer to the following manual.
→ Refer to the FX3U-16CCL-M User's Manual.

1.6.1 Station number setting

Setting items	Range	Description
× 10	0, 1	Online: 0 (Master station) Line test: 0 to 16
× 1	0 to 9	17 to 99 is the setting error.

1.6.2 Transmission rate setting, line test, hardware test

Setting	Description	Status
0	Transmission rate 156 Kbps	Online
1	Transmission rate 625 Kbps	
2	Transmission rate 2.5 Mbps	
3	Transmission rate 5 Mbps	
4	Transmission rate 10 Mbps	Line test
5	Transmission rate 156 Kbps	
6	Transmission rate 625 Kbps	
7	Transmission rate 2.5 Mbps	
8	Transmission rate 5 Mbps	
9	Transmission rate 10 Mbps	
A	Transmission rate 156 Kbps	Hardware test
B	Transmission rate 625 Kbps	
C	Transmission rate 2.5 Mbps	
D	Transmission rate 5 Mbps	
E	Transmission rate 10 Mbps	
F	Unusable	

2. Installation

For details on installation, refer to the following manual.
→ Refer to the FX3U-16CCL-M User's Manual.

INSTALLATION PRECAUTIONS	WARNING
• Make sure to cut off all phases of the power supply externally before attempting installation work. Failure to do so may cause electric shock or damage to the product.	

INSTALLATION PRECAUTIONS	CAUTION
<ul style="list-style-type: none"> Use the product within the generic environment specifications described in PLC main unit manual (Hardware Edition). Never use the product in areas with excessive dust, oily smoke, conductive dusts, corrosive gas (salt air, Cl₂, H₂S, SO₂ or NO₂), flammable gas, vibration or impacts, or expose it to high temperature, condensation, or rain and wind. If the product is used in such conditions, electric shock, fire, malfunctions, deterioration or damage may occur. Do not touch the conductive parts of the product directly. Doing so may cause device failures or malfunctions. Install the product securely using a DIN rail or mounting screws. Install the product on a flat surface. If the mounting surface is rough, undue force will be applied to the PC board, thereby causing nonconformities. When drilling screw holes or wiring, make sure or cutting or wire debris does not enter the ventilation slits. Failure to do so may cause fire, equipment failures or malfunctions. Be sure to remove the dust proof sheet from the PLC's ventilation slits when installation work is completed. Failure to do so may cause fire, equipment failures or malfunctions. Make sure to attach the top cover, offered as an accessory, before turning on the power or initiating operation after installation or wiring work. Failure to do so may cause electric shock. Connect extension cables securely to their designated connectors. Loose connections may cause malfunctions. 	

2.1 Connection with PLC

Only one FX3U-16CCL-M can be connected to the right side of a PLC main unit or extension unit/block (including special function units/blocks).
For connection to an FX3GC/FX3UC Series PLC or FX2NC Series extension block, an FX2NC-CNV-IF or FX3UC-1PS-5V is required.
For connection to FX5U/FX5UC PLC, FX5-CNV-BUS or FX5-CNV-BUSC is required.
For details, refer to the respective PLC manual.

- Refer to the FX3G Series User's Manual - Hardware Edition.
- Refer to the FX3GC Series User's Manual - Hardware Edition.
- Refer to the FX3U Series User's Manual - Hardware Edition.
- Refer to the MELSEC IQ-F FX5U User's Manual (Hardware).
- Refer to the MELSEC IQ-F FX5UC User's Manual (Hardware).

2.2 Mounting

The product is mounted by the following method.

- DIN rail mounting
 - Direct mounting (mounting screw: M4 screw)
- For details, refer to the respective PLC manual.
→ Refer to the FX3G Series User's Manual - Hardware Edition.
→ Refer to the FX3GC Series User's Manual - Hardware Edition.
→ Refer to the FX3U Series User's Manual - Hardware Edition.
→ Refer to the MELSEC IQ-F FX5U User's Manual (Hardware).
→ Refer to the MELSEC IQ-F FX5UC User's Manual (Hardware).

3. Specification

For details on specifications, refer to the following manual.
→ Refer to the FX3U-16CCL-M User's Manual.

DESIGN PRECAUTIONS	WARNING
<ul style="list-style-type: none"> When executing control (data changes) to an operating PLC, construct an interlock circuit in the sequence program so that the entire system operates conservatively. Additionally, when executing control such as program changes and operation status changes (status control) to an operating PLC, thoroughly read the manual and sufficiently confirm safety in advance. Especially in control from external equipment to a PLC in a remote place, problems in the PLC may not be able to be handled promptly due to abnormality in data transfer. Construct an interlock circuit in the sequence program. At the same time, determine the actions in the system between the external equipment and the PLC for protection against abnormalities in data transfer. Make sure to have the following safety circuits outside the PLC to ensure safe system operation even during external power supply problems or PLC failure. Otherwise, malfunctions may cause serious accidents. 1) Most importantly, have the following: an emergency stop circuit, a protection circuit, an interlock circuit for opposite movements (such as normal vs. reverse rotation), and an interlock circuit (to prevent damage to the equipment at the upper and lower positioning limits). 2) Note that when the PLC CPU detects an error, such as a watchdog timer error, during self-diagnosis, all outputs are turned off. Also, when an error that cannot be detected by the PLC CPU occurs in an input/output control block, output control may be disabled. External circuits and mechanisms should be designed to ensure safe machinery operation in such a case. 	

DESIGN PRECAUTIONS	CAUTION
<ul style="list-style-type: none"> Make sure to observe the following precautions in order to prevent any damage to the machinery or accidents due to abnormal data written to the PLC under the influence of noise: 1) Do not bundle the control line together with or lay it close to the main circuit or power line. As a guideline, lay the control line at least 100 mm (3.94") or more away from the main circuit or power line. Noise may cause malfunctions. 2) Ground the shield wire or shield of a shielded cable. Do not use common grounding with heavy electrical systems. 3) Install module so that excessive force will not be applied to the power supply terminal block or CC-Link connection terminal block. Failure to do so may result in wire damage/breakage or PLC failure. 	

DISPOSAL PRECAUTIONS	CAUTION
<ul style="list-style-type: none"> Please contact a certified electronic waste disposal company for the environmentally safe recycling and disposal of your device. 	

TRANSPORTATION AND STORAGE PRECAUTIONS	CAUTION
<ul style="list-style-type: none"> The PLC is a precision instrument. During transportation, avoid impacts larger than those specified in the general specifications of the PLC main unit manual by using dedicated packaging boxes and shock-absorbing pallets. Failure to do so may cause failures in the PLC. After transportation, verify operation of the PLC and check for damage of the mounting part, etc. 	

3.1 Applicable PLC

Model name	Applicability
FX3G Series PLC	Ver. 1.00 and later ³ Only one FX3U-16CCL-M unit can be connected in a main unit.
FX3GC Series PLC	Ver. 1.40 and later ³ Only one FX3U-16CCL-M unit can be connected in a main unit.
FX3U Series PLC	Ver. 2.20 and later ³ Only one FX3U-16CCL-M unit can be connected in a main unit.
FX3UC Series PLC ¹	Ver. 2.20 and later ³ Only one FX3U-16CCL-M unit can be connected in a main unit.
FX5U PLC ²	From first production Only one FX3U-16CCL-M unit can be connected in a CPU module.
FX5UC PLC ²	From first production Only one FX3U-16CCL-M unit can be connected in a CPU module.

- *1 An FX2NC-CNV-IF or FX3UC-1PS-5V is necessary to connect the FX3U-16CCL-M with the FX3GC/FX3UC PLC.
- *2 An FX5-CNV-BUS or FX5-CNV-BUSC is necessary to connect the FX3U-16CCL-M with the FX5U/FX5UC PLC.
- *3 The version number can be checked by reading the last three digits of device D8001/D8101.

3.2 General Specifications

Items other than the following are equivalent to those of the PLC main unit.
For general specifications, refer to the manual of the PLC main unit.
→ Refer to the FX3G Series User's Manual - Hardware Edition.
→ Refer to the FX3GC Series User's Manual - Hardware Edition.
→ Refer to the FX3U Series User's Manual - Hardware Edition.
→ Refer to the MELSEC IQ-F FX5U User's Manual (Hardware).
→ Refer to the MELSEC IQ-F FX5UC User's Manual (Hardware).

Item	Specification
Dielectric withstand voltage	500 V AC for one minute
Insulation resistance	5 MΩ or higher by 500 V DC insulation resistance tester

3.3 Power Supply Specification

Item	Specification	
External power supply	Power supply voltage	24 V DC +20% -15% Ripple (p-p) within 5%
	Permitted instantaneous power failure time	Operation continues when the instantaneous power failure is shorter than PS1:1 ms.
	Current consumption	240mA
Internal power supply	Power supply voltage	5 V DC of PLC is not used. (5 V DC is converted from 24 V DC external power supply).
	Current consumption	Make sure to observe the power-on timing and the procedure.

3.4 Performance Specification

Item	Specification
Applicable function	Master station function (The local station and standby master station functions are not provided.)
CC-Link applicable version	Ver. 2.00 (Ver. 1.10 also supported.)
Station number	0 (set by rotary switch)
Transmission rate	156 Kbps/625 Kbps/2.5 Mbps/5 Mbps/10 Mbps (set by rotary switch)
Maximum total cable length (maximum transmission distance)	1,200 m maximum (varies depending on the transmission speed.) For details, refer to the FX3U-16CCL-M User's Manual.
Connection cable ¹	CC-Link dedicated cable/ CC-Link dedicated high-performance cable/ Ver. 1.10 compatible CC-Link dedicated cable
Maximum number of connectable stations	1) Remote I/O stations: 8 maximum (Each stations occupies 32 I/O points of the PLC.) 2) Remote device stations + Intelligent device stations: 8 maximum (The total number of RX/RV points is 256 or less.)
Maximum number of I/O points per system	When using an FX3U/FX3UC/FX5U/FX5UC PLC 1) + 2) total number of points ≤ 384 points 1) (Actual number of PLC I/O points) + (Number of points occupied by special function blocks) + (Number of points occupied by the FX3U-16CCL-M: 8 points) ≤ 256 points 2) 32 × Number of remote I/O stations ≤ 256 points When using an FX3G/FX3GC PLC 32 × Number of remote I/O stations ≤ 128 points
Number of link points per station ²	Remote I/O (RX, RV): 32 points Remote register (RWw): 4 points (Master station) → Remote device station/ intelligent device station) Remote register (RWv): 4 points (Remote device station/intelligent device station) → Master station)
Communication with PLC ³	By FROM and TO instructions or direct specification of buffer memory (FX3U/FX3UC) via the buffer memory.
Number of I/O occupied points	8 points
Number of connectable units to the main unit	1 (An FX3U-16CCL-M cannot be attached to main unit with an FX2N-16CCL-M.)

- *1 CC-Link dedicated cables, Ver. 1.10 compatible CC-Link dedicated cable and CC-Link dedicated high-performance cable cannot be used together. Also attach the terminating resistor which matches the kind of the cable.
- *2 Indicates the number of link points for remote net ver. 1 mode. For the number of link points for remote net ver. 2 mode/remote net additional mode, refer to the FX3U-16CCL-M User's Manual.
- *3 For details of other applied instructions and methods, refer to the FX3S/FX3G/FX3GC/FX3U/FX3UC Programming Manual.

「电器电子产品有害物质限制使用标识要求」的表示方式

Note: This symbol mark is for China only.

含有害6物质的名称, 含有量, 含有部品
本产品中所含有的有害6物质的名称, 含有量, 含有部品如下表所示。

部件名称	有害物质					
	铅 (Pb)	汞 (Hg)	镉 (Cd)	六价铬 (Cr (VI))	多溴联苯 (PBB)	多溴二苯醚 (PBDE)
可编程控制器	○	○	○	○	○	○
外壳	○	○	○	○	○	○